



Q.E.E.D.

QUALITY ELECTRONIC DESIGN

Q.E.E.D.
WWW.QEED.IT
INFO@QEED.IT

D.E.M. S.p.A
WWW.DEM-IT.COM

ANALOG SIGNAL DISPLAY

Q-DISP-C



USER'S MANUAL

The displays Q-DISP-C, prepared for mounting on the back panel, 96x48mm, will allow you to count and totalize.

It is possible to have a high power or low voltage AC / DC and have up to configurable outputs of relay outputs and analog outputs



Q-DISP-C

ANALOG SIGNAL DISPLAY

Q-DISP-C-x-x-x-x

Q-DISP-C-L (Low Voltage Supply)
Q-DISP-C-H (High Voltage Supply)

Q-DISP-C-x-R (n°1 Relay output)
Q-DISP-C-x-R-R (n°2 Relays output)
Q-DISP-C-x-R-R-R (n°3 Relays output)
Q-DISP-C-x-AO (n°1 Analog Output)
Q-DISP-C-x-AO-R (n°1 AO, n°1 Relay)
Q-DISP-C-x-AO-R-R (n°1AO, n°2 Relays)
Q-DISP-C-x-AO-AO (n°2 AO)
Q-DISP-C-x-AO-AO-R (n°2 AO, n°1 Relay)
Q-DISP-C-x-AO-AO-AO (n°3 AO)



1. Meter Q-DISP-C

Panel meter 96x48mm counter, ratemeter, periodmeter

Panel meter configurable as impulse counter, ratemeter and periodmeter. Accepts wide range of signal types such as Push-pull, NPN, PNP, Namur, TTL, inductive, mechanical, ... also monodirectional and bidirectional encoder signals (quadrature signals).

Highly configurable, with pull-up/pull-down resistors, trigger levels, pulse detection on raising or falling edge, excitation voltage and antirrebound filters. 'Trigger Sense' utility for easy trigger level adjustment.

Scalable reading by configurable multiplier and divider factors (1 to 999999). Configurable decimal point position. Resolution 6 digits (999999/-199999).

Excitation voltage configurable to 5V, 9V, 15V and 18V.

Up to 3 relay outputs controlled from the instrument alarms, can be increased to 6 relay outputs (with simplified functionality, see section 2). Configurable direct access to setpoint values modification on key UP (▲).

Standard 96x48mm DIN size. Universal AC and DC power options. Up to three control and/or signal retransmission modules. IP54 front protection, with optional IP65.

Connections via plug-in screw terminals and configuration via three front push-buttons. For industrial applications.

Counter modes

Counter functionality allows to choose between 5 counting modes (simple counter, quadrature counter, counter with inhibit control, differential counter and counter with add/subtract control). Instrument has two impulse input channels (A and B) and selectable ascending or descending counting modes.

Reset function is accessible from rear terminal and front push-button. The front reset can be enabled or disabled. Configurable preset value. Alarm activation can be associated to an action : 'reset to zero', 'return to preset' or 'no action'. Relays activation and deactivation times are independent and configurable.

Alarm functions with 'reset to zero' or 'return to preset' create a continuous counting cycle (instrument cycles from 'preset value' to 'alarm value'). Instrument provides a internal cycle counter, accessible to the operator.

Memory retention in case of power loss or deactivation. When power is back again, instrument recovers the last reading and configuration.

Maximum counting frequency is 250 KHz in 'FAST' mode.

Ratemeter mode

Ratemeter function allows to choose between normal ratemeter (one single input channel) or bidirectional ratemeter (quadrature ratemeter) with detection of clockwise / counter-clockwise sense of turn.

In ratemeter mode, the instrument counts the number of impulses during a fixed period of time, and calculates the frequency.

For low frequency applications, a special 'SLOW' mode is available, which offers the fastest response time for low frequency applications. See section 1.13 for more information.

Recursive filter 'Average' to stabilize unstable readings.

Maximum frequency in ratemeter mode is 900KHz and minimum frequency (with 'SLOW' mode activated) is 0.001 Hz (1mHz).

Periodmeter mode

Periodmeter mode detects the signal time between impulses. For long period applications, a special 'SLOW' mode is available which offers the fastest response time for low frequency applications. See section 1.13 for more information.

1.1 Order reference

| Model | Power | Option1 | Option2 | Option3 |
|--------------------------|---|--|--|--|
| Q-DISP - C | H | --- | --- | --- |
| | -H (85-265 Vac/dc) -L (11-60 Vdc and 24/48 Vac) | -R (1 relay) -AO (Analogue output) - (empty) | -R (1 relay) -AO (Analogue output) - (empty) | -R (1 relay) -AO (Analogue output) - (empty) |



Index

| | | | |
|--|----|--|----|
| 1. Meter Q-DISP-C | 2 | 1.12.3 "cnF.1" - Counter | 10 |
| 1.1 Order reference | 2 | 1.12.4 "cnF.2" - Counter quadrature | 10 |
| 1.2 Start-up | 3 | 1.12.5 "cnF.3" - Counter + Inhibit | 10 |
| 1.3 Front view | 4 | 1.12.6 "cnF.4" - Counter + Control A/S | 10 |
| 1.4 Power connections | 4 | 1.12.7 "cnF.5" - Counter differential | 11 |
| 1.5 Sensor configuration and connections | 4 | 1.12.8 "cnF.6" - Ratemeter | 11 |
| 1.6 Rear view | 4 | 1.12.9 "cnF.7" - Ratemeter quadrature | 11 |
| 1.7 Signal connections | 4 | 1.12.10 "cnF.8" - Periodmeter | 11 |
| 1.8 Technical data | 5 | 1.12.11 Menu Sensor | 12 |
| 1.8 Technical data (cont.) | 5 | 1.12.12 Menu Alarms | 12 |
| 1.9 Mechanical dimensions (mm) | 5 | 1.12.13 Menu Tools | 13 |
| 1.10 Configuration menu | 6 | 1.12.14 Menu OptX - Options | 13 |
| 1.10 Configuration menu (cont.) | 7 | 1.13 Mode 'SLOW' | 13 |
| 1.10.1 Menu Cnf.1 - Counter | 8 | 1.14 Mode 'FAST' | 13 |
| 1.10.2 Menu Cnf.2 - Counter quadrature | 8 | 1.15 'Trigger Sense' | 13 |
| 1.10.3 Menu Cnf.3 - Counter + Inhibit | 8 | 1.16 Messages and errors | 14 |
| 1.10.4 Menu Cnf.4 - Counter add/subtract | 8 | 1.17 Operating the menus | 14 |
| 1.10.5 Menu Cnf.5 - Counter differential | 8 | 1.18 Accessing the instrument | 14 |
| 1.10.6 Menu Cnf.6 - Ratemeter | 8 | 1.19 Warranty | 15 |
| 1.10.7 Menu Cnf.7 - Ratemeter quadrature | 9 | 1.20 Installation precautions | 15 |
| 1.10.8 Menu Cnf.8 - Periodmeter | 9 | 2. Control modules | 15 |
| 1.11 Default factory configuration | 9 | 2.1 Module R | 15 |
| 1.12 Configuration menu descriptions | 10 | 2.2 Module AO | 15 |
| 1.12.1 Function mode | 10 | | |
| 1.12.2 Decimal point | 10 | | |

1.2 Start-up

To start-up the instrument, take the following steps into consideration :

1. Input signal connections → see section 1.5 y 1.7
2. Power connections → see section 1.4
3. Sensor configuration → see section 1.12.11 (menu "SnSr"). Select from the "Auto" menu entry one of the listed sensors, to configure the default values for that sensor (values indicated in Table1 (see section 1.5)). Values can also be manually configured :
 - 3.1. pull-up/pull-down resistors on channel A, B and Reset
 - 3.2. trigger level (shared for channels A and B). (Trigger level for reset is fixed at 2,5V).
 - 3.3. antirrebound filter (shared for channels A and B)
 - 3.4. excitation voltage value

4. Select the function mode (counter, ratemeter, periodmeter, ...) and values for multiplier and divider (menu "Func").

- 4.1. function mode → see section 1.12.1
- 4.2. decimal point position "dP" → see section 1.12.2
- 4.3. multipliers and dividers → see sections 1.12.3 to 1.12.10 (menu "cnF.X") depending on the function mode selected.

5. Advanced configuration

To modify setpoint values, presets, activation edges, etc ... see next sections in this document.



1.3 Front view

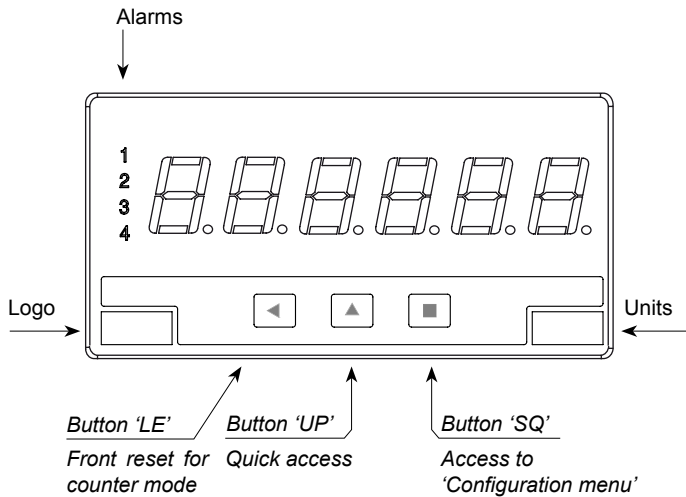

1.6 Rear view

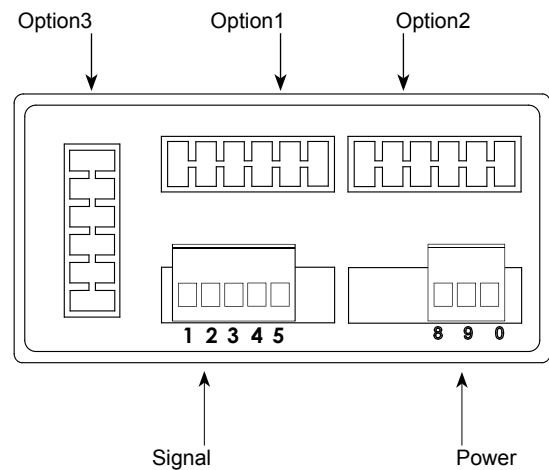

1.4 Power connections

Earth connection - Although a terminal is offered for earth connection, the connection is optional. The instrument does not need this connection for correct functioning nor for compliance with the security regulations.

Fuse - To comply with security regulation 61010-1, add to the power line a protection fuse acting as disconnection element, easily accessible to the operator and identified as a protection device.

- Power "H" fuse 250mA time-lag
- Power "L" fuse 400mA time-lag

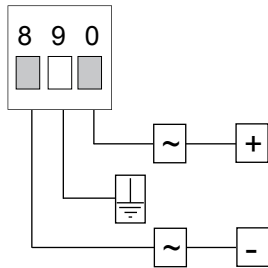

1.7 Signal connections

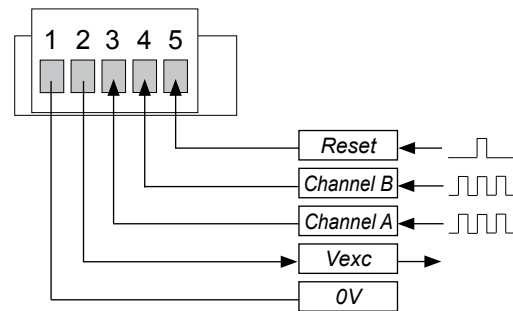

1.5 Sensor configuration and connections

Examples of connections and configurations for different sensor types.

Connections are indicated for channel A. For channel B connect the same way, but in channel B.

Note - values indicated on Table 1 are usual values. Confirm with your sensor datasheet the specifications that apply and adapt the configuration values and connections as needed.

| Sensor | Connections (for channel A) | Pulls | Vexc | Antirrebound filter | Trigger |
|--------------------|-----------------------------|-----------|------|---------------------|---------|
| Mechanical contact | 0V Channel A | Pull-up | No | 100mSec. | 2,5V |
| Namur | Channel A Vexc | Pull-down | 9V | No | 3,0V |
| NPN 2 wires | 0V Channel A | Pull-up | 18V | No | 2,5V |
| NPN 3 wires | 0V Channel A Vexc | Pull-up | 18V | No | 2,5V |
| PNP 2 wires | 0V Channel A | Pull-down | 18V | No | 2,5V |
| PNP 3 wires | 0V Channel A Vexc | Pull-down | 18V | No | 2,5V |
| Push-pull | 0V Channel A Vexc | No | 18V | No | 2,5V |
| TTL CMOS Pick-up | 0V Channel A | No | 5V | No | 2,5V |
| AC <30V Inductive | 0V Channel A | No | No | No | 0V |

Table 1 - Configuration and connections for different sensor types
Examples for channel A connections



1.8 Technical data

| | |
|-------------------------|--|
| Digits | 6 |
| Type | 7 segments, red |
| Height | 14 mm |
| Display maximum | 999999 |
| Display minimum | -199999 |
| Decimal point | selectable 8.8.8.8.8.8. |
| Overrange | configurable 'flash', 'reset', 'preset' |
| Underrange | configurable 'flash', 'reset', 'preset' |
| Signals accepted | impulses and frequencies |
| Connections | 2 wires, 3 wires and quadrature |
| Signal types | Push-pull, NPN, PNP, Namur, Pick-up, TTL, inductive, mechanical, quadrature, ... |
| Maximum Vdc at input | ±30Vdc |
| Input impedance | 2K4 if pull resistors on 470K if pull resistors off |

Maximum and minimum frequencies

| | | |
|-------------------------|------|---------------------|
| Counter | | |
| with 'FAST' mode | max. | 250 KHz |
| without 'FAST' mode | max. | 9 KHz |
| Counter quadrature x1 | max. | 17 KHz |
| Counter quadrature x2 | max. | 16 KHz |
| Counter quadrature x4 | max. | 11 KHz |
| Counter + inhibit | max. | 9 KHz |
| Counter + control A/S | max. | 9 KHz |
| Counter differential | max. | 9 KHz |
| | | |
| Ratemeter | max. | 900 KHz |
| with 'SLOW' mode | max. | 200Hz |
| with 'SLOW' mode | min. | 1mHz |
| Ratemeter quadrature x1 | max. | 17 KHz |
| Ratemeter quadrature x2 | max. | 16 KHz |
| Ratemeter quadrature x4 | max. | 11 KHz |
| | | |
| Periodmeter | max. | 900 KHz |
| with 'SLOW' mode | max. | 200 Hz |
| with 'SLOW' mode | min. | 1mHz (1000 seconds) |

Accuracy

| | |
|--------------------------|----------|
| Of the quartz oscillator | ±0.01% |
| Thermal drift | 20ppm/°C |

Excitation voltage

| | |
|-----------------|-----------------------------------|
| Configurable to | 5V, 9V, 15V, 18V |
| Current | 70mA max. |
| Protection | yes, current limited to 70mA max. |

Refresh

| | |
|--------------------|-----------------------------------|
| Display refresh | 15 / second |
| Number of readings | 100 / second in counter modes |
| Number of readings | 1 / GATE in rate and period modes |

Power

| | |
|-------------|---------------------------|
| Power "H" | 85 to 265 Vac/dc |
| Power "L" | 11 to 60 Vdc and 24/48Vac |
| Consumption | <4W |

1.8 Technical data (cont.)

| | |
|----------------------------|--|
| Isolation | 3500Veff for power "H" 2000Veff for power "L" |
| (tested 60 seconds) | |
| Configuration | 3 frontal push buttons (rear jumper for coupling selection) |
| Functions available | |
| Multiplier and divider | yes, configurable |
| Preset | yes, configurable |
| Edge selection | yes, configurable |
| 'SLOW' frequency mode | yes, configurable |
| Recursive filter | yes, configurable |
| Pull resistors | yes, configurable |
| Trigger levels | yes, configurable |
| Excitation voltage | yes, configurable |
| Antirrebound filter | yes, configurable |
| Memory | yes, maximum ,minimum, cycles |
| Memory of counter | yes, recovers data on power loss |
| Reset configurable | yes, front and/or rear reset and/or assigned to setpoint |
| | |
| Zeros to the left | yes, configurable |
| Password | yes, configurable |
| Brightness control | yes, 5 levels |

Optional boards maximum 3 (see section 2)

Mechanical

| | |
|-------------------|---------------------------|
| Mounting | panel |
| Connections | plug-in screw terminals |
| Weight | <150 grams |
| Housing materials | ABS, polycarbonate |
| Front size | 96x48mm |
| Panel cut-out | 92x44mm |
| Deep from panel | 91mm (including terminal) |

Protection

| | |
|------------------------------------|--|
| IP54 standard | |
| IP65 optional (Front sealed. | |
| Opening the front breaks the seal) | |

| | |
|------------------------------|--------------|
| Temperature Operation | 0 to 50°C |
| Temperature Storage | -20 to +70°C |
| Warm-up | 15 minutes |

1.9 Mechanical dimensions (mm)

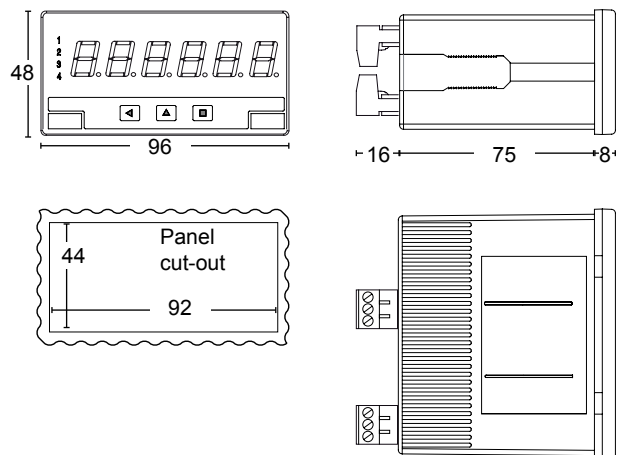

1.10 Configuration menu

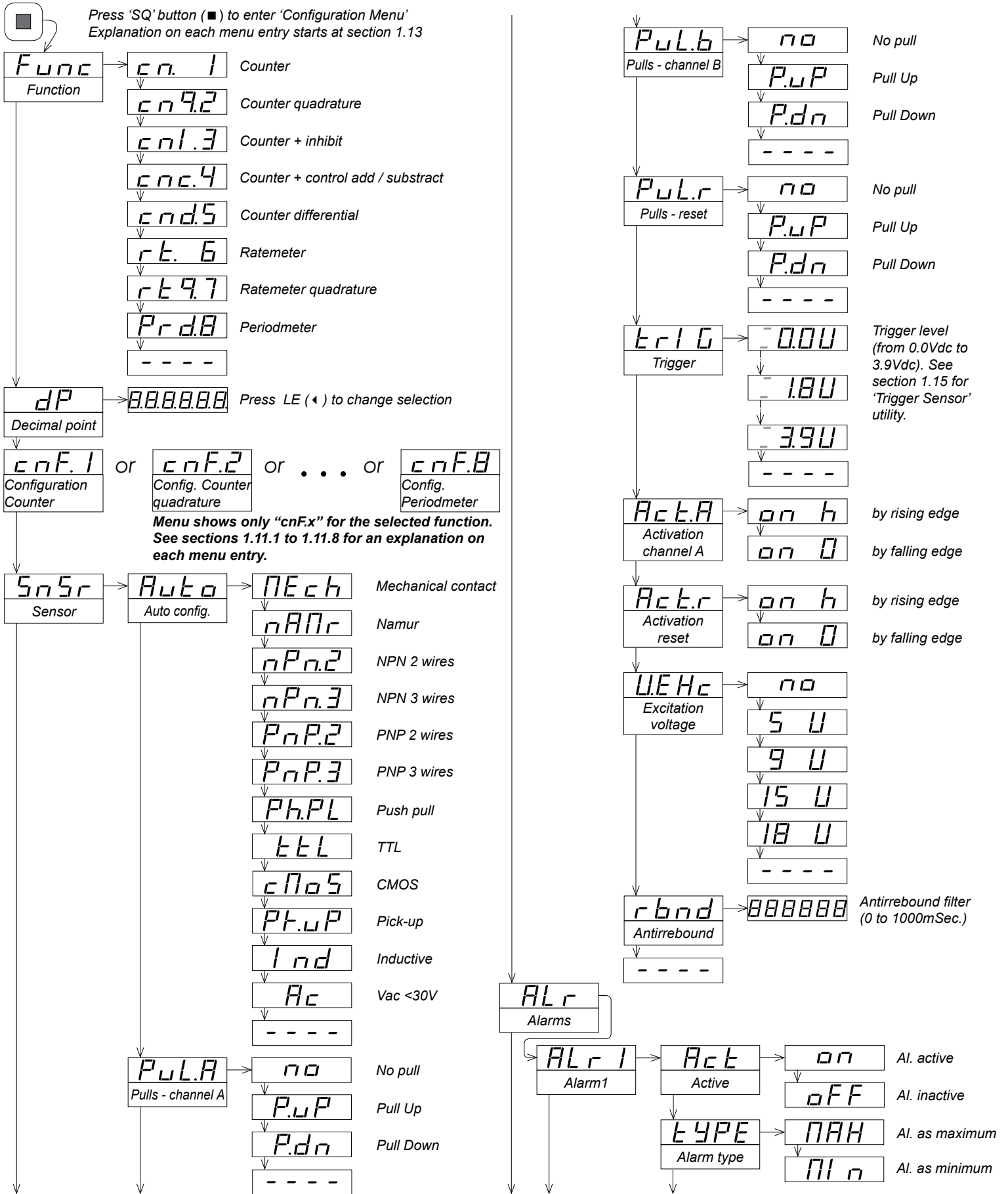

1.10 Configuration menu (cont.)

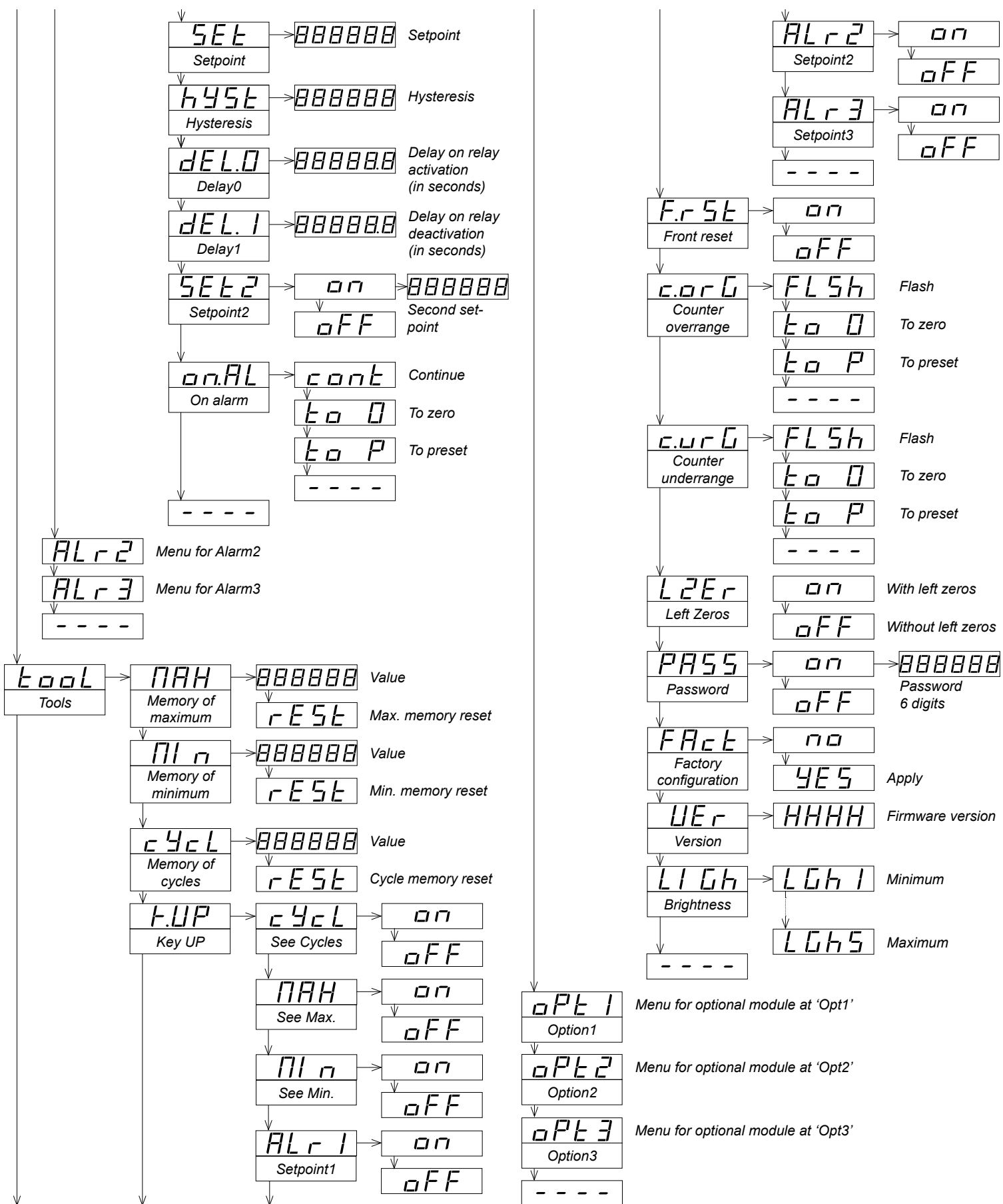

1.10.1 Menu Cnf.1 - Counter

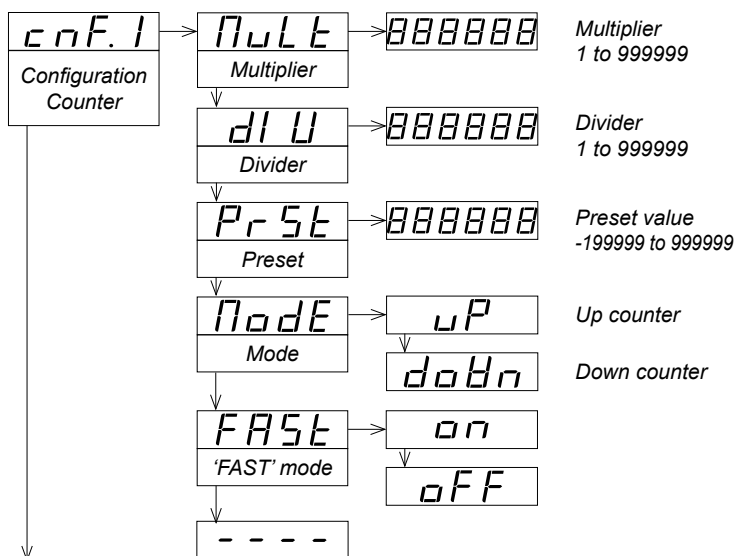

1.10.2 Menu Cnf.2 - Counter quadrature

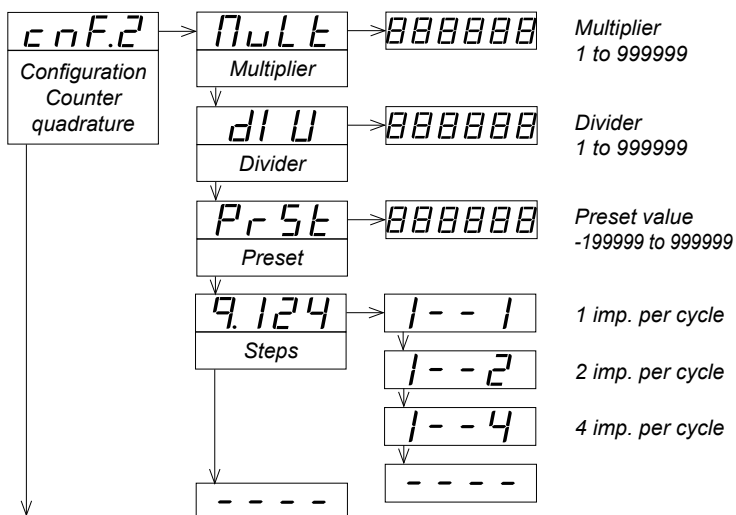

1.10.3 Menu Cnf.3 - Counter + Inhibit

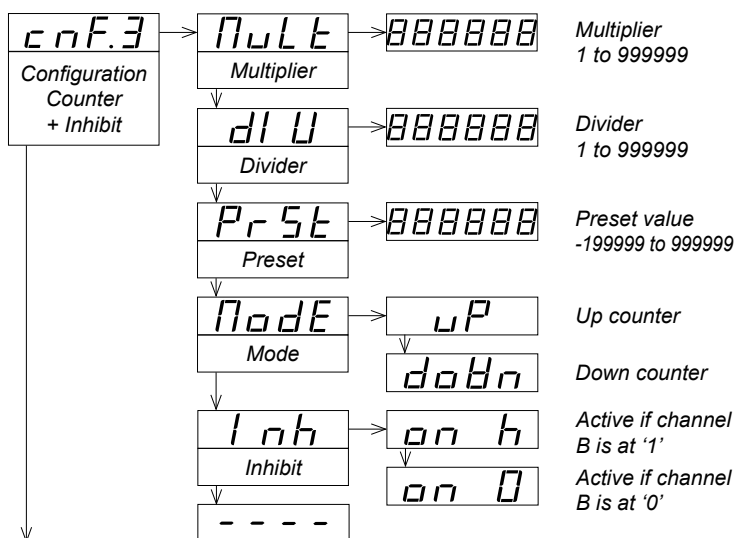

1.10.4 Menu Cnf.4 - Counter add/subtract

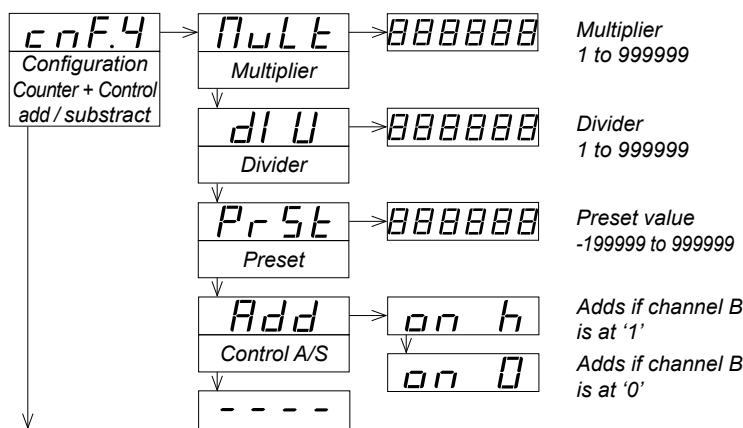

1.10.5 Menu Cnf.5 - Counter differential

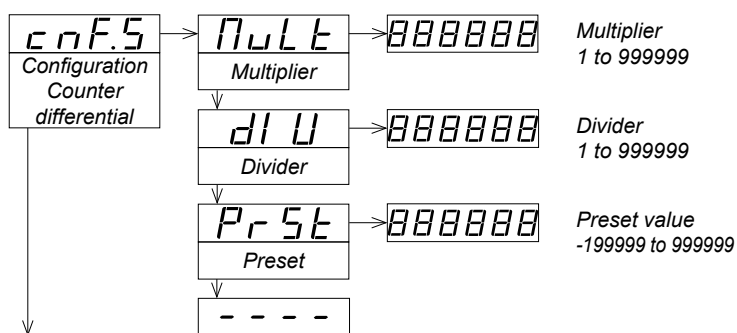

1.10.6 Menu Cnf.6 - Ratemeter

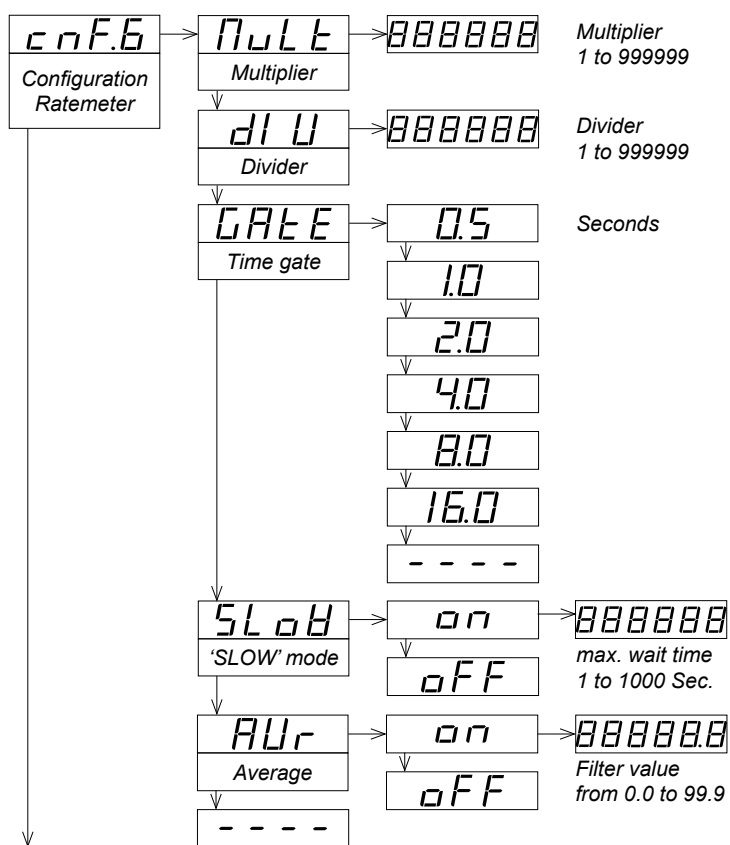

1.10.7 Menu Cnf.7 - Ratemeter quadrature

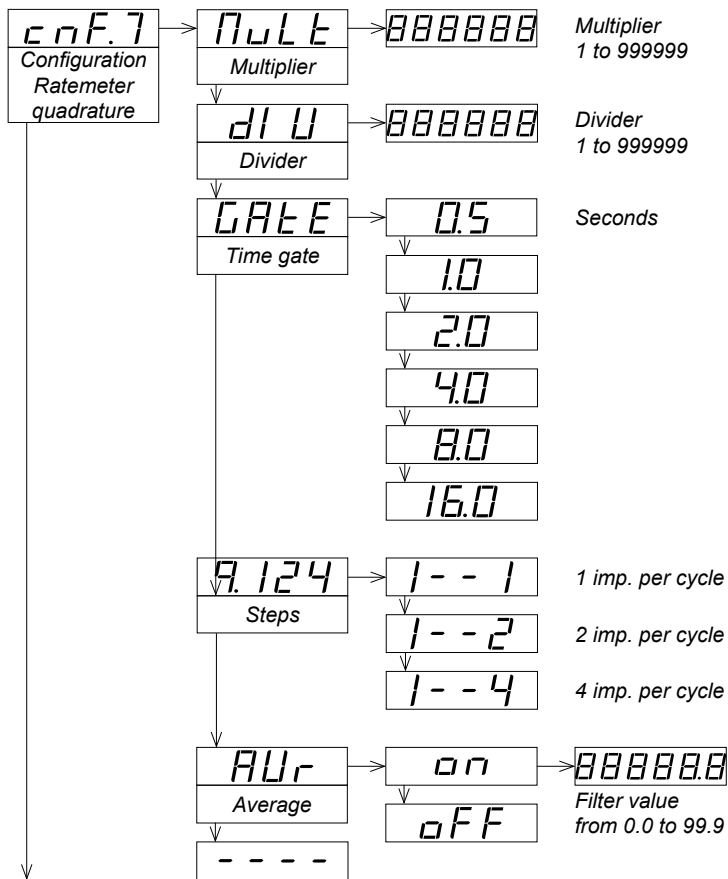

1.10.8 Menu Cnf.8 - Periodmeter

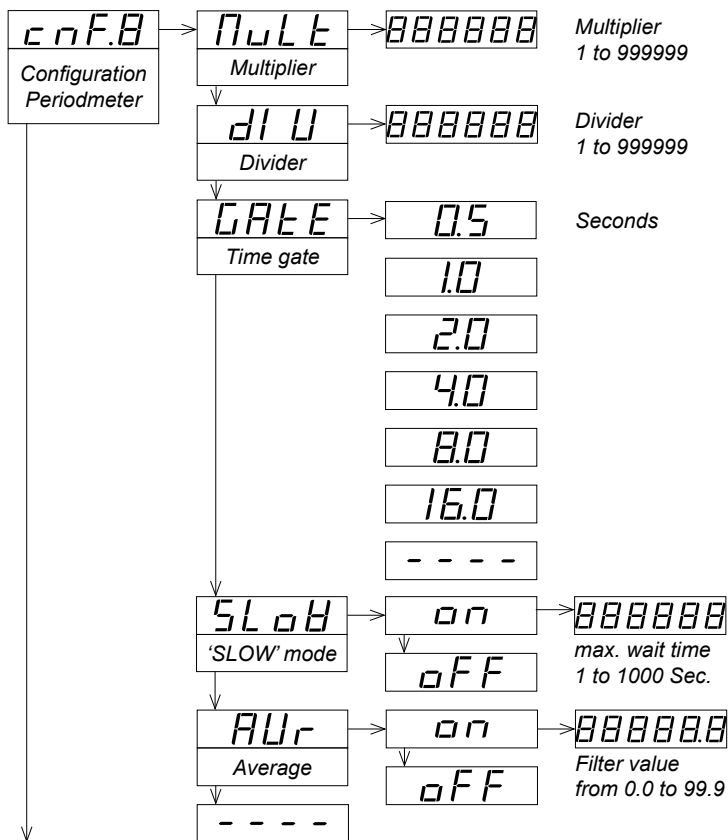

1.11 Default factory configuration

| | |
|----------------------|------------------|
| Function ("Func") | counter ("cn.1") |
| Decimal point ("dP") | no |

Counter configuration ("cnF.1")

| | |
|---------------------|-------------------|
| Multiplier ("Mult") | x1 |
| Divider ("dIV") | /1 |
| Preset ("PrSt") | 0 |
| Mode ("ModE") | up counter ("uP") |
| 'FAST' ("FASt") | off ("oFF") |

Sensor ("SnSr")

| | |
|--------------------------------|----------------------|
| Pull channel A ("PuL.A") | no pull ("no") |
| Pull channel B ("PuL.b") | no pull ("no") |
| Pull reset ("PuL.r") | pull-up ("P.uP") |
| Trigger ("trIG") | 2,5Vdc |
| Activation channel A ("Act.A") | rising edge ("on_h") |
| Activation reset ("Act.r") | rising edge ("on_h") |
| Excitation voltage ("V.EXc") | 15Vdc |
| Antirrebound filter | 0 mSeconds |

Tools ("tooL")

| | |
|-----------------------|----------------|
| Memory of maximum | -199999 |
| Memory of minimum | 999999 |
| Memory of cycles | 0 |
| Key UP ("K.uP") | |
| Cycles | Off |
| Maximum | Off |
| Minimum | Off |
| Alarm1 setpoint | Off |
| Alarm2 setpoint | Off |
| Alarm3 setpoint | Off |
| Front reset ("F.rSt") | On |
| Counter overrange | Flash ("FLSh") |
| Counter underrange | Flash ("FLSh") |
| Left zeros | Off |
| Password | Off |
| Brightness | 3 |

Alarms 1,2 and 3

| | |
|------------------------------|----------------|
| Active | Off (disabled) |
| Type | maximum alarm |
| Setpoint | 1000 |
| Hysteresis | 0 counts |
| Activation delay ("dEL.0") | 0.0 seconds |
| Deactivation delay ("dEL.1") | 0.0 seconds |
| Setpoint2 | Off |
| On Alarm | continue |

Ratemeter ("cnF.6") and Periodmeter ("cnF.8") configuration

| | |
|--------------------------|-------------|
| Multiplier ("Mult") | x1 |
| Divider ("dIV") | /1 |
| Time gate ("GAtE") | 0.5 seconds |
| 'SLOW' mode ("SLoW") | Off |
| Recursive filter ("AVr") | Off |



1.12 Configuration menu descriptions

1.12.1 Function mode

Select de function of the instrument.

“cn.1” - Counter - Input impulses on channel A. Channel B disabled.

“cnq.2” - Counter for quadrature signals - Input impulses in quadrature (bidirectional encoder) on channels A and B.

“cni.3” - Counter + inhibit control - Input impulses on channel A. Inhibition control inhibit on channel B.

“cnc.4” - Counter + control add / subtract - Input impulses on channel A. Control for function add or subtract, on channel B.

“cnd.5” - Counter differential - Input impulses with add function on channel A. Input impulses with subtract function on channel B.

“rt.6” - Ratemeter - Input impulses on channel A. Channel B disabled.

“rtq.7” - Ratemeter for quadrature signals - Input impulses in quadrature (bidirectional encoder) on channels A and B.

“Prd.8” - Periodmeter - Input impulses on channel A. Channel B disabled.

The selected function (“Func”) modifies the configuration menu (“cnF.x”) presented by the instrument.

1.12.2 Decimal point

Select the position for the decimal point. Modify with the LE button and validate with the SQ button.

1.12.3 “cnF.1” - Counter

The “cnF.1” menu is visible only when function mode “cn.1” ‘counter’ is selected. Impulses received are internally counted, multiplied by the “MuLt” parameter, divided by the “dIV” parameter, and the result is updated on display.

Multiplier (“MuLt”) - Value from 1 to 999999. Multiplier factor to be applied to the total number of impulses counted.

Divider (“dIV”) - Value from 1 to 999999. Divider factor to be applied to the total number of impulses counted.

Preset (“PrSt”) - Value from 999999 to -199999. Reset activation loads on display the preset value.

Mode (“ModE”) - Value “uP” / “doWn”. Select “uP” for up counter (received impulses add). Select “doWn” for down counter (impulses received subtract).

‘FAST’ mode (“FAST”) - Value “on” / “oFF”. See section 1.14

1.12.4 “cnF.2” - Counter quadrature

The “cnF.2” menu is visible only when function mode “cnq.2” ‘counter quadrature’ is selected. Impulses received are internally counted, multiplied by the “MuLt” parameter, divided by the “dIV” parameter, and the result is updated on display.

Multiplier (“MuLt”) - Value from 1 to 999999. Multiplier factor to be applied to the total number of impulses counted.

Divider (“dIV”) - Value from 1 to 999999. Divider factor to be applied to the total number of impulses counted.

Preset (“PrSt”) - Value from 999999 to -199999. Reset activation loads on display the preset value.

Edges (“q.124”) - Value “1--1”, “1--2” or “1--4”. Select “1--1” to count 1 impulse per quadrature cycle. Select “1--2” to count 2 impulses per quadrature cycle. Select “1--4” to count 4 impulses per quadrature cycle.

1.12.5 “cnF.3” - Counter + Inhibit

The “cnF.3” menu is visible only when function mode “cni.3” ‘counter + inhibit’ is selected. Impulses received are internally counted, multiplied by the “MuLt” parameter, divided by the “dIV” parameter, and the result is updated on display.

Multiplier (“MuLt”) - Value from 1 to 999999. Multiplier factor to be applied to the total number of impulses counted.

Divider (“dIV”) - Value from 1 to 999999. Divider factor to be applied to the total number of impulses counted.

Preset (“PrSt”) - Value from 999999 to -199999. Reset activation loads on display the preset value.

Mode (“ModE”) - Value “uP” / “doWn”. Select “uP” for up counter (received impulses add). Select “doWn” for down counter (impulses received subtract).

Inhibit (“Inh”) - Value “on_h” / “on_0”. Select “on_h” to inhibit counting when channel B is at logic state ‘1’. Select “on_0” to inhibit counting when channel B is at logic state ‘0’.

1.12.6 “cnF.4” - Counter + Control A/S

The “cnF.4” menu is visible only when function mode “cnc.4” ‘counter + control add / subtract’ is selected. Impulses received are internally counted, multiplied by the “MuLt” parameter, divided by the “dIV” parameter, and the result is updated on display.

Multiplier (“MuLt”) - Value from 1 to 999999. Multiplier factor to be applied to the total number of impulses counted.

Divider (“dIV”) - Value from 1 to 999999. Divider factor to be applied to the total number of impulses counted.

Preset (“PrSt”) - Value from 999999 to -199999. Reset activation loads on display the preset value.



Control A/S (“Add”) - Value “on_h” / “on_0”. Select “on_h” to add the impulses received on channel A when channel B is at logic state ‘1’ (impulses received on channel A are subtracted if channel B is at logic state ‘0’). Select “on_0” to add the impulses received on channel A when channel B is at logic state ‘0’ (impulses received on channel A are subtracted if channel B is at logic state ‘1’).

1.12.7 “cnF.5” - Counter differential

The “cnF.5” menu is visible only when function mode “cnd.5” ‘counter differential’ is selected. Impulses received are internally counted, multiplied by the “MuLt” parameter, divided by the “dIV” parameter, and the result is updated on display. Impulses received on channel A always add. Impulses received on channel B always subtract.

Multiplier (“MuLt”) - Value from 1 to 999999. Multiplier factor to be applied to the total number of impulses counted.

Divider (“dIV”) - Value from 1 to 999999. Divider factor to be applied to the total number of impulses counted.

Preset (“PrSt”) - Value from 999999 to -199999. Reset activation loads on display the preset value.

1.12.8 “cnF.6” - Ratemeter

The “cnF.6” menu is visible only when function mode “rt.6” ‘ratemeter’ is selected. Based on the number of impulses received during the time window defined at the “GAtE” parameter, frequency is calculated (impulses received / ‘GATE’). The frequency value obtained is multiplied by the “MuLt” parameter, divided by the “dIV” parameter, and the result is updated on display. Value on display is updated every X seconds (X value defined at the “GAtE” parameter).

Multiplier (“MuLt”) - Value from 1 to 999999. Multiplier factor to be applied to the total number of impulses counted.

Divider (“dIV”) - Value from 1 to 999999. Divider factor to be applied to the total number of impulses counted.

Time window (“GAtE”) - Selectable 0.5, 1.0, 2.0, 4.0, 8.0 and 16.0 seconds. Time window to count received impulses and calculate the frequency. Inactive if ‘SLOW’ mode is active.

‘SLOW’ mode (“SLoW”) - Selectable “on” / “oFF”. Select “on” to activate and define the value for parameter ‘Max. waiting time’ between 1 and 1000 seconds. See section 1.13 for more information on ‘SLOW’ mode. ‘SLOW’ mode disables the value selected at “GAtE”.

Average (AVR) - Value from “0.0” to “99.9”. Recursive filter. The severity of the filter increases with the value selected.

1.12.9 “cnF.7” - Ratemeter quadrature

The “cnF.7” menu is visible only when function mode “rtq.7” ‘ratemeter quadrature’ is selected. Based on the number of impulses received during the time window defined at the “GAtE” parameter, frequency is calculated (impulses received / ‘GATE’). The frequency value obtained is multiplied by the “MuLt” parameter, divided by the “dIV” parameter, and the result is updated on display. Value on display is updated every X seconds (X value defined at the “GAtE” parameter).

Multiplier (“MuLt”) - Value from 1 to 999999. Multiplier factor to be applied to the total number of impulses counted.

Divider (“dIV”) - Value from 1 to 999999. Divider factor to be applied to the total number of impulses counted.

Time window (“GAtE”) - Selectable 0.5, 1.0, 2.0, 4.0, 8.0 and 16.0 seconds. Time window to count received impulses and calculate the frequency.

Edges (“q.124”) - Value “1--1”, “1--2” o “1--4”. Select “1--1” to count 1 impulse per quadrature cycle. Select “1--2” to count 2 impulses per quadrature cycle. Select “1--4” to count 4 impulses per quadrature cycle.

Average (AVR) - Value from “0.0” to “99.9”. Recursive filter. The severity of the filter increases with the value selected.

1.12.10 “cnF.8” - Periodmeter

The “cnF.8” menu is visible only when function mode “Prd.8” ‘periodmeter’ is selected. Based on the number of impulses received during the time window defined at the “GAtE” parameter, period is calculated (‘GATE’ / impulses received). The period value obtained is multiplied by the “MuLt” parameter, divided by the “dIV” parameter, and the result is updated on display. Value on display is updated every X seconds (X value defined at the “GAtE” parameter).

Multiplier (“MuLt”) - Value from 1 to 999999. Multiplier factor to be applied to the total number of impulses counted.

Divider (“dIV”) - Value from 1 to 999999. Divider factor to be applied to the total number of impulses counted.

Time window (“GAtE”) - Selectable 0.5, 1.0, 2.0, 4.0, 8.0 and 16.0 seconds. Time window to count received impulses and calculate the frequency. Inactive if ‘SLOW’ mode is active.

‘SLOW’ mode (“SLoW”) - Selectable “on” / “oFF”. Select “on” to activate and define the value for parameter ‘Max. waiting time’ between 1 and 1000 seconds. See section 1.13 for more information on ‘SLOW’ mode. ‘SLOW’ mode disables the value selected at “GAtE”.

Average (AVR) - Value from “0.0” to “99.9”. Recursive filter. The severity of the filter increases with the value selected.



1.12.11 Menu Sensor

Configures the input channels to recognize impulses from sensors connected on channels A, B and reset.

Automatic sensor configuration ("Auto") - Select the type of sensor to automatically configure sensor parameters as shown on Table1 (section 1.5). Configured parameters are: pull resistors, excitation voltage, antirrebound filter and trigger level. Parameters can be changed on each parameter menu entry. The list of predefined sensors are : mechanical contact ("MEch"), namur ("nAMr"), NPN 2 wires ("nPn.2"), NPN 3 wires ("nPn.3"), PNP 2 wires ("PnP.2"), PNP 3 wires ("PnP.3"), push-pull ("Ph.PL"), TTL ("tTL"), CMOS ("cMoS"), pick-up ("Pk.uP") inductive ("Ind") and AC signals <30Vdc ("Ac").

Pulls on channel A ("PuL.A") - Value "no", "P.uP" o "P.dn". Select "P.uP" to activate the pull-up resistor on channel A. Select "P.dn" to activate the pull-down resistor on channel A. Select "no" to deactivate pulls on channel A. Trigger is automatically set to 2,5V when "P.uP" or "P.dn" are selected.

Pulls on channel A ("PuL.b") - See previous entry 'Pulls on channel A'.

Pulls del reset ("PuL.r") - See previous entry 'Pulls on channel A'. Trigger value for reset channel is fixed at 2,5V.

Trigger ("trIG") - Values from 0,0V to 3,9V. Select the trigger value. The input signal is considered to be a logical '1' when the input signal value is higher than the trigger value (in Vdc). The input signal is considered to be a logical '0' when the input signal value is lower than the trigger value (in Vdc). Trigger value is the same for channels A and B. Trigger value for reset channel is fixed at 2,5V. See section 1.15 for 'Trigger Sensor' utility.

Activation for channel A ("Act.A") - Value "on_h" / "on_0". Select "on_h" to enable detection of impulses on channel A by rising edge. Select "on_0" to enable detection of impulses on channel A by falling edge.

Activation for reset ("Act.r") - Value "on_h" / "on_0". Select "on_h" to enable reset activation by rising edge. Select "on_0" to enable reset activation by falling edge.

Excitation voltage ("V.Exc") - Select value for excitation voltage to power-up the transducer, between 5V, 9V, 15V and 18V. Select "no" to disable excitation voltage.

Antirrebound filter ("rbnd") - Antirrebound filter. Selectable from 0 to 1000 mSeconds. For mechanical contact sensors set value at 100mSeconds. When an impulse is received, the filter activates and no new impulses are counted for the duration of the filter value. When the filter time is over, next impulse received is counted and filter activates again.

1.12.12 Menu Alarms

Configuration menu for 3 alarms that control relays R1 (see section 2.1) installable at slots 'Opt1', 'Opt2' and 'Opt3'. (Special modules R2, R4 and R6 allow for up to 6 simple relay outputs. See section 2.3 for more information).

Active ("ACT") - Value "on" / "oFF". Defines if the instrument has to manage this alarm or not. Select "oFF" for alarm not managed.

Type ("tYPE") - Value "MAX" / "MIn". Defines the behavior of the alarm as maximum or minimum alarm. The alarms configured as maximum are activated when the display value is equal or higher than the setpoint. The alarms configured as maximum are deactivated when the display is lower than the setpoint. The alarms configured as minimum have the inverse behavior.

Setpoint ("SEt") - Value from "999999" to "-199999". Alarm setpoint.

Hysteresis ("hYSt") - Value from "0" to "999999". Counts of hysteresis. The hysteresis applies on the deactivation of the alarm.

Delay 0 ("dEL.0") - Value from "0.0" to "99.9" seconds. Activation delay for relays R1. Relays and front led are activated X seconds after alarm activation.

Delay 1 ("dEL.1") - Value from "0.0" to "99.9" seconds. Deactivation delay for relays R1. Relays and front led are deactivated X seconds after alarm deactivation.

Setpoint2 ("SEt2") - Value from "-199999" to "999999". Second setpoint. The second setpoint allows for the creation of activation windows. If the alarm is configured as maximum with setpoint 1000 and setpoint2 is configured at 1500, the alarm will be activated between 1000 and 1500 and the alarm will be deactivated when display is <1000 and >1500. Setpoint2 is affected on the same way as the setpoint with hysteresis and delays.

On Alarm ("on.AL") - Value "cont", "to_0" or "to_p". Behavior when the display reaches the setpoint value. Applies only to counter modes. Select "cont" to continue counting. Select "to_0" to reset display to '0'. Select "to_p" to jump display to preset value. Selection of "to_0" or "to_p", configures "dEL.1" by default to 1 second.



1.12.13 Menu Tools

Configuration of non usual parameters and special tools.

Maximum ("MAX") - Maximum memory value and memory reset function.

Minimum ("MIn") - Minimum memory value and memory reset function.

Cycles ("cYcL") - Cycle memory value and memory reset function.

Key UP ("K.uP") - Configuration of information accessible from key UP (▲). Select "on" to activate desired entries. Pressing key UP (while in normal working mode), will visualize each one of the parameters selected.

"cYcL" - Visualization of number of cycles

"MAX" - Visualization of memory of maximum

"MIn" - Visualization of memory of minimum

"ALr1" - Visualization and modification of setpoint1 value

"ALr2" - Visualization and modification of setpoint2 value

"ALr3" - Visualization and modification of setpoint3 value

Front reset ("F.rSt") - Value "on" / "oFF". Select "on" to activate reset when pressing front key LE (◀). Select "oFF" to disable front reset (pressing LE key will make no function).

Counter overrange ("c.orG") - Defines the function to activate in case of counter overrange (display is higher than 999999). Select "FLSh" to set display in flash mode. Select "to_0" to reset display to '0'. Select "to_p" to jump display to preset value.

Counter underrange ("c.urG") - Defines the function to activate in case of counter underrange (display is lower than -199999). Select "FLSh" to set display in flash mode. Select "to_0" to reset display to '0'. Select "to_p" to jump display to preset value.

Left Zero ("LZEr") - Value "On/Off". Select "On" to visualize zeros to the left.

Password ("PASS") - Select a 6 digit number to act as password. This password will be requested when entering the 'Configuration Menu' (key SQ ■). To deactivate the password select "oFF".

Factory configuration ("FAct") - Factory default configuration. Select "yES" to activate the factory default configuration.

Version ("VEr") - Firmware version installed..

Light ("LIGH") - Brightness. Select between 5 predefined levels of brightness.

1.12.14 Menu OptX - Options

Menu entries "oPt1", "oPt2" y "oPt3" give access to the configuration menus for the optional modules installed on slots 'Opt1', 'Opt2' y 'Opt3'. This menu depends on the installed option. If there is no option installed the instrument shows "nonE". Relay modules 'R1' are controlled from the standard alarm menu (see section 1.12.12).

1.13 Mode 'SLOW'

Optional mode available in Ratemeter ("rt.6") and Period-meter ("Prd.8") modes. Activate the 'SLOW' mode enables the fastest response time for low frequency applications. In this mode, the frequency and period calculation is calculated directly by measuring the time between two consecutive impulses. The measure is updated each time a new impulse is received.

The 'SLOW' mode needs the user to define the parameter 'maximum waiting time' between impulses (with a value between 1 and 1000 seconds). If the configured time is gone with no impulses received, the frequency value is set to '0' (period value is also set to '0'). Parameter 'GAtE' has no application in this mode.

The 'SLOW' mode is functional for frequencies below 200Hz.

1.14 Mode 'FAST'

Optional mode available in Counter mode ("cn.1"). Activate the 'FAST' mode enables a higher frequency input detection rate on channel A, up to 250KHz, for simple counter "cn.1" mode only.

The activation of 'FAST' mode has the following restrictions : impulse detection edge is fixed to 'raising edge', and the first edge (raising or falling edge) received after a power-up (or configuration change) is not detected as impulse but will be used for internal initialization.

1.15 'Trigger Sense'

The 'Trigger Sense' provides information on the input signal state, while adjusting the trigger level. The 'trigger' menu ("■" / "SnSr" / "trIG"), displays the actual value of the trigger level (in Vdc) and two leds to the left named 'up' led and 'down' led.

| | |
|------------|---|
| Led 'up' |  |
| Led 'down' |  |

Input signal at a 'high level' state is represented by the activation of the 'up' led. Input signal at a 'low level' state is represented by the activation of the 'down' led.

For a correct trigger configuration, modify the trigger level until both 'up' and 'down' leds are being alternatively activated. This alternative activation state indicates that the instrument is correctly detecting the '1' and '0' input signal states.



1.16 Messages and errors

The instrument can display the following messages and errors.

“Err.1” Password entered is not correct.

“Err.2” The instrument has detected an installed option but was unable to communicate.

“Err.8” The instrument is limiting the current at Vexc.

“999999” + flash. The display is in overrange (real display should be higher than 999999 and can not be displayed).

“-199999” + flash. The display is in underrange (real display should be lower than -199999 and can not be displayed).

“E.101” Option is installed but the type can not be recognized.

1.17 Operating the menus

The instrument has two menus accessible to the user :

‘Configuration menu’ (key SQ) (■)

‘Quick access menu’ (key UP) (▲)

The *‘configuration menu’* allows to change the configuration of the instrument. Access to the *‘configuration menu’* can be protected enabling the *‘PASSWORD’* function. During operation with the *‘configuration menu’* the alarms are kept *‘on-hold’*. When leaving the *‘configuration menu’* the instrument performs a restart, and new configuration is applied. On restart of the instrument, also the optional modules are restarted (relays, analogue outputs, ...).

The *‘quick access menu’* is a configurable menu where the user can configure access to the following information : memory values for maximum, minimum and cycles, and setpoint values for alarms 1, 2 and 3. The list of configurable parameters is accessible at *“tooL”* / *“k.uP”*. Alarm setpoints can be modified when enabled in the *‘quick access menu’*. the *‘PASSWORD’* function does not block access to the *‘quick access menu’*. While working in the *‘quick access menu’* the instrument keeps working as normal the background. There is no reset when leaving the *‘quick access menu’*.

Rollback - After 30 seconds without interaction from the operator, the instrument leaves the active menu and returns normal working mode. All changes are discarded.

Key SQ (■) - Selects the menu entry currently displayed. When entering a numeric value (for example a setpoint value) validates the value on display.

Key UP (▲) - Moves vertically on the menu entries. When entering a numeric value (for example a setpoint value) modifies the current digit by increasing its value up from 0 to 1, 2, 3, 4, 5, 6, 7, 8, 9.

Key LE (◀) - Leaves the current menu. Pressing LE several times will leave all menus. When leaving all menus in the configuration menu, changes will be saved. When entering a numeric value (for example a setpoint value) it moves from one digit to the next. Each digit value can then be modified with the UP button.

1.18 Accessing the instrument

You may need to access the inside of the instrument to insert additional modules. Use a flat screwdriver to unlock the upper clips marked with “A”. Then unlock the lower clips marked with “B” and remove the front cover. Let the inside of the instrument slide out of the housing.

To reinsert the instrument make sure that all modules are correctly connected to the pins on the display module. Place all the set into the housing, assuring that the modules correctly fit into the internal guiding slides of the housing. Once introduced, place again the front cover by clipping first the upper clips “A” and then the lower clips “B”.

Important - If your instrument was delivered with the IP65 front seal option, accessing the inside of the instrument will permanently break the IP65 seal on the areas of clips “A” and “B”.

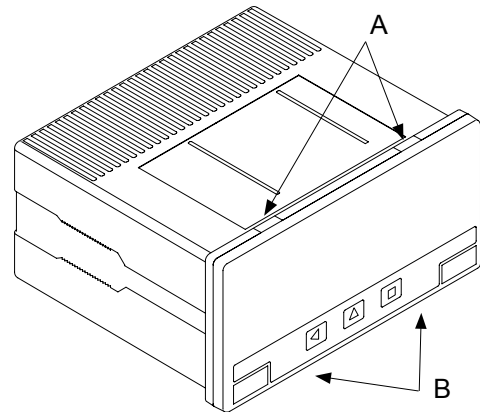

Risk of electric shock. Removing the front cover will grant access to the internal circuits. Disconnect the input signal to prevent electric shock to the operator. Operation must be performed by qualified personnel only.



1.19 Warranty

All instruments are warranted against all manufacturing defects for a period of 24 MONTHS from the shipment date. This warranty does not apply in case of misuse, accident or manipulation by non-authorized personnel. In case of malfunction get in contact with your local provider to arrange for repair. Within the warranty period and after examination by the manufacturer, the unit will be repaired or substituted when found to be defective. The scope of this warranty is limited to the repair cost of the instrument, not being the manufacturer eligible for responsibility on additional damages or costs. .

1.20 Installation precautions



Risk of electrical shock. Instrument terminals can be connected to dangerous voltage.



Instrument protected with double isolation. No earth connection required.



Instrument is in conformity with CE rules and regulations. See "CE Declaration of Conformity" further in this document.

This instrument has been designed and verified according to the 61010-1 CE security regulation, and is designed for applications on industrial environments. See the "CE Declaration of Conformity" further in this document for information on the category of measure and the degree of pollution levels that apply.

Installation of this instrument must be performed by qualified personnel only. This manual contains the appropriate information for the installation. Using the instrument in ways not specified by the manufacturer may lead to a reduction on the specified protection level. Disconnect the instrument from power before starting any maintenance and / or installation action.

The instrument does not have a general switch and will start operation as soon as power is connected. The instrument does not have protection fuse, the fuse must be added during installation.

The instrument is designed to be panel mounted. An appropriate ventilation of the instrument must be assured. Do not expose the instrument to excess of humidity. Maintain clean by using a humid rag and do NOT use abrasive products such as alcohols, solvents, etc.

General recommendations for electrical installations apply, and for proper functionality we recommend : if possible, install the instrument far from electrical noise or magnetic field generators such as power relays, electrical motors, speed variators, ... If possible, do not install along the same conduits power cables (power, motor controllers, electrovalves, ...) together with signal and/or control cables.

Before proceeding to the power connection, verify that the voltage level available matches the power levels indicated in the label on the instrument.

In case of fire, disconnect the instrument from the power line, fire alarm according to local rules, disconnect the air conditioning, attack fire with carbonic snow, never with water.

2. Control modules

2.1 Module R

Module with 1 relay. Up to a maximum of three R modules can be installed in one Q-DISP panel meter.

| | |
|-----------------|---------------------------------------|
| Relay type | 3 contacts (Common, NC, NO) |
| Maximum current | 8A (resistive load) |
| Voltage | 250 Vac continuously |
| Installable at | Option1 and/or Option2 and/or Option3 |

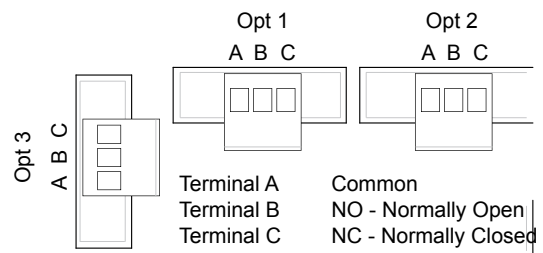

2.2 Module AO

Module with 1 analogue output. Configurable 4/20mA or 0/10Vdc. Output signal proportional to the reading. Scaling through the frontal keypad. Up to a maximum of three AO modules can be installed in one Q-ISP panel meter.

| | |
|----------------|---------------------------------------|
| Output | 4/20mA, 0/10Vdc selectable |
| Accuracy | 0.1% FS |
| Isolated | yes, 1000Vdc |
| Thermal drift | 50 ppm/°C for Vdc 60 ppm/°C for mA |
| Installable at | Option1 and/or Option2 and/or Option3 |

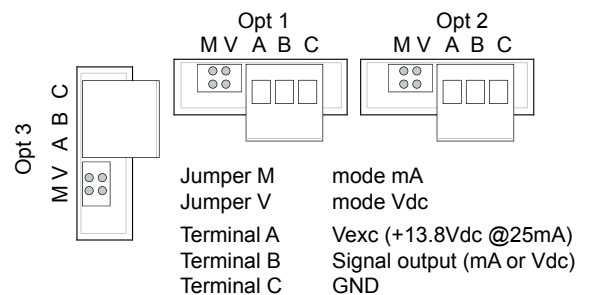

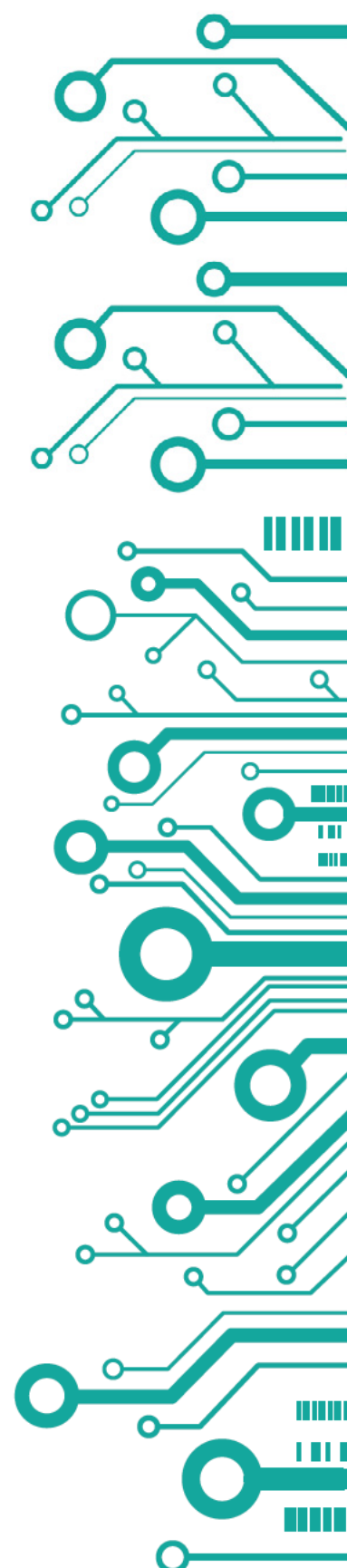

www.qeed.it info@qeed.it

Sales department..... sales@qeed.it

Technical department.....technical@qeed.it

Z.I. Villanova, 20 - 32013 Longarone (BL), Italy

Ph. +39 0437 761021

Fax +39 0437 760024

