

# Threaded seals with large diaphragm and separable mounting parts S-Comp

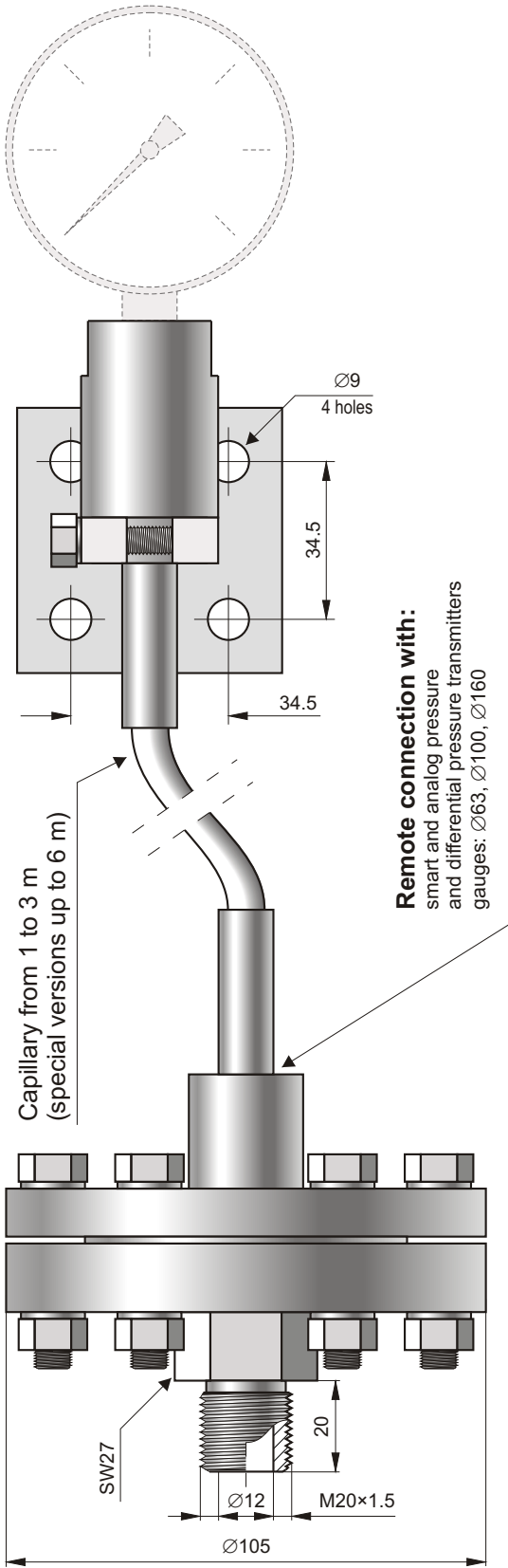

**Mounting part with process connection  
M20x1.5 (P type); G1/2" (GP type)**

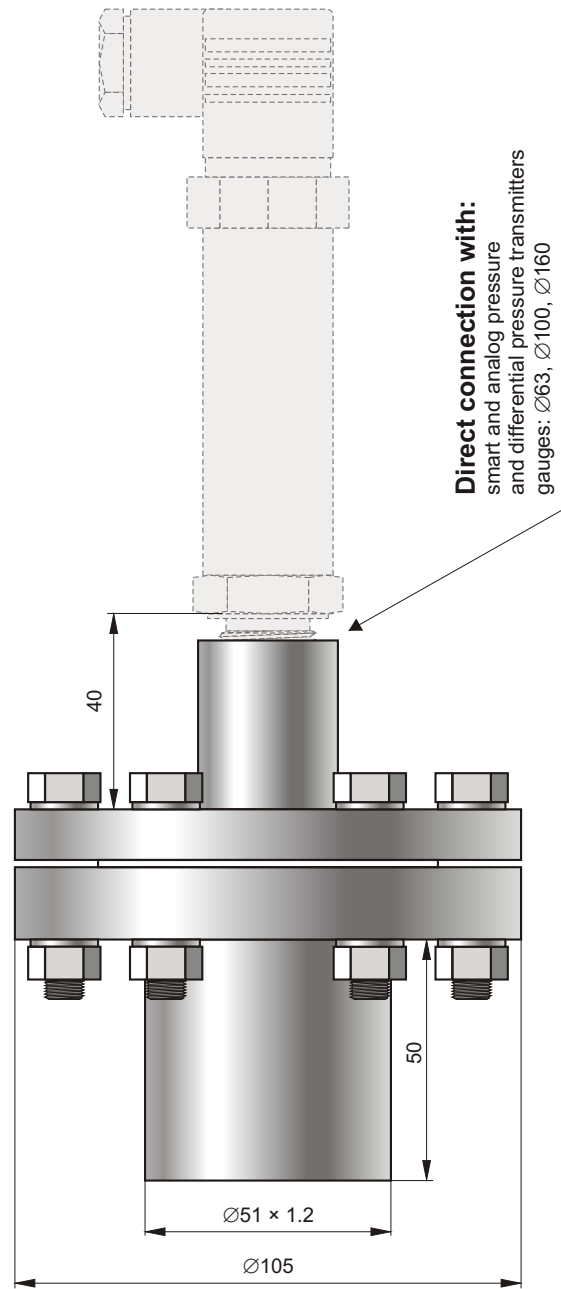

**Mounting part with fitting tube for welding in**

## Application

The diaphragm seal is a pressure-transmitting, diaphragm-type device. The pressure signal is sent to the co-operating pressure measuring device (pressure transmitter, pressure gauge) through manometric liquid filling the space between the separating diaphragm of the seal and the pressure measuring device. The diaphragm seal task is to isolate the pressure measuring device from damaging impacts caused by either medium or installation:

- low or high temperature, increased viscosity, impurities;
- vibrations of the installation (remote diaphragm seal);
- pressure fluctuations.

S-Comp diaphragm seals have a large separating diaphragm (Ø70) while retaining a compact economic overall design. Benefits of S-Comp diaphragm seals include:

- the ability to take measurements within a narrow range;
- simplicity of assembly.

### Maximum measuring range 0...16 bar.

#### Recommended minimum measuring range (bar), depending on the type of the set: pressure measuring device - diaphragm seal

Diaphragm seal type	Transmitters APCE-2000*, PCE-28	Gauge Ø63	Gauge Ø100	Gauge Ø160
direct	0.2	1	1	1
remote	0.5	2.5	2.5	2.5

\* The ranges given in the table for the smart APCE-2000 transmitter should be taken as set ranges.

#### Additional absolute zero error resulting from ambient temperature fluctuations, depending on the type of the set: pressure transmitter - diaphragm seal

Diaphragm seal type	Absolute error of zero
direct	0.6 mbar / 10°C
Remote (2m capillary)	2 mbar / 10°C

An additional zero error, resulting from temperature fluctuations in a medium, depends on the temperature gradient in the oil-based diaphragm sealing system. The error value is, in any case, significantly smaller than the error value shown in the table.

#### Medium temperature range

-30...200°C for remote diaphragm seal

-30...150°C for direct diaphragm seal

#### Material of diaphragm, flange and mounting part

00H17N14M2 (316Lss)

#### Special versions

Diaphragm made of Hastelloy C 276

Capillary outlet at the side of the diaphragm seal

Direct diaphragm seal for medium temp. over 150°C

Others

## Ordering procedure

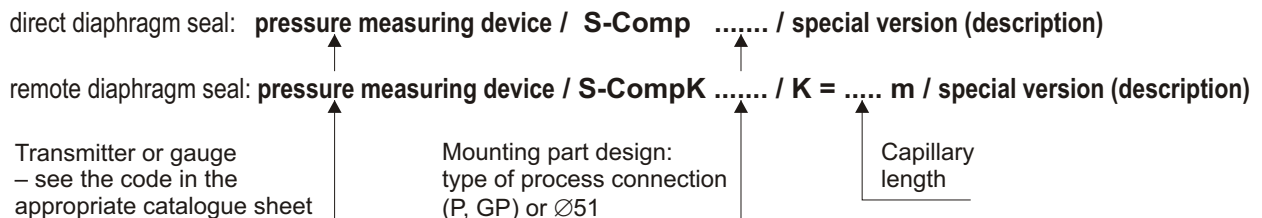

**Example:** MS-100 gauge, measuring range 0÷6bar, process connection outlet bottom, remote threaded seal with large diaphragm and separable mounting part with process connection M20×1.5, capillary length 1.5 m.

**MS-100 / 0 ÷ 6 bar / S-CompK M20×1.5 / K = 1.5 m**