

Smart differential pressure transmitter with two diaphragm seals model APR-2200ALW or APRE-2200

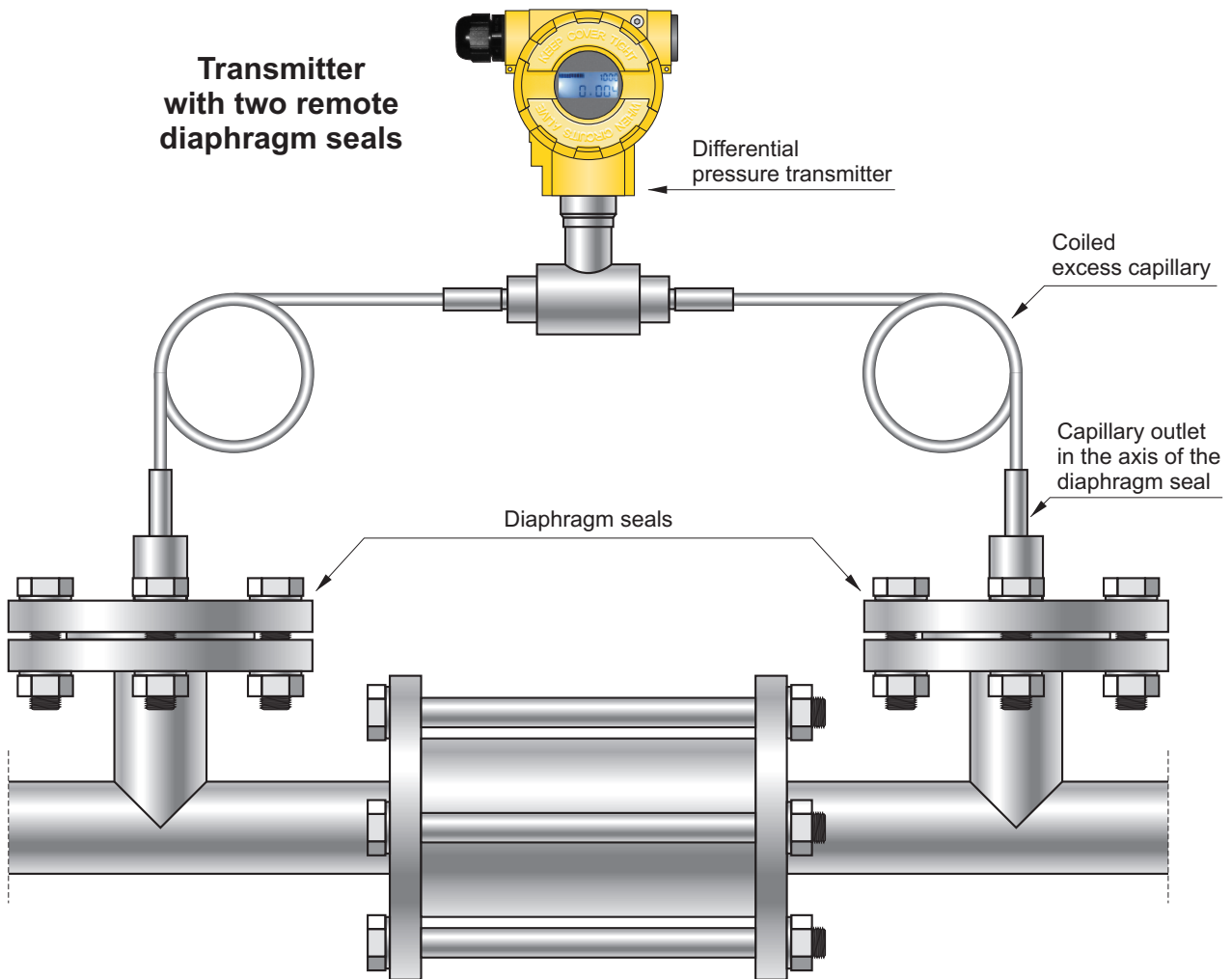

- ✓ Several applications, including hydrostatic measurement of: levels in closed tanks, density and phase boundaries
- ✓ Ability to configure measuring range locally
- ✓ Digital PROFIBUS PA signal
- ✓ 4...20 mA output signal + HART protocol
- ✓ Accuracy 0.1%
- ✓ ATEX certificates (intrinsic safety, explosion proof)
- ✓ Fully welded active measuring element which guarantees Tightness of oil system for many years.



Example of a filter loss measurement

Recommendations

The version of the transmitter with two remote diaphragm seals is recommended for the measurement of pressure differences when the hydrostatic pressure of the manometric fluid in the capillaries (which depends on the vertical spacing of the seals) is significantly less than the measuring range of the transmitter. The best metro-

logical results are obtained when the applied capillaries are identical, as short as possible, and terminated with identical seals. At such a configuration additional temperature errors, related to the remote sealing, affect both of the measurement chambers of the differential pressure transmitter in the same way, and thus cancel each other out.

Transmitter with two types of diaphragm seal: one – direct diaphragm seal and the other – remote diaphragm seal

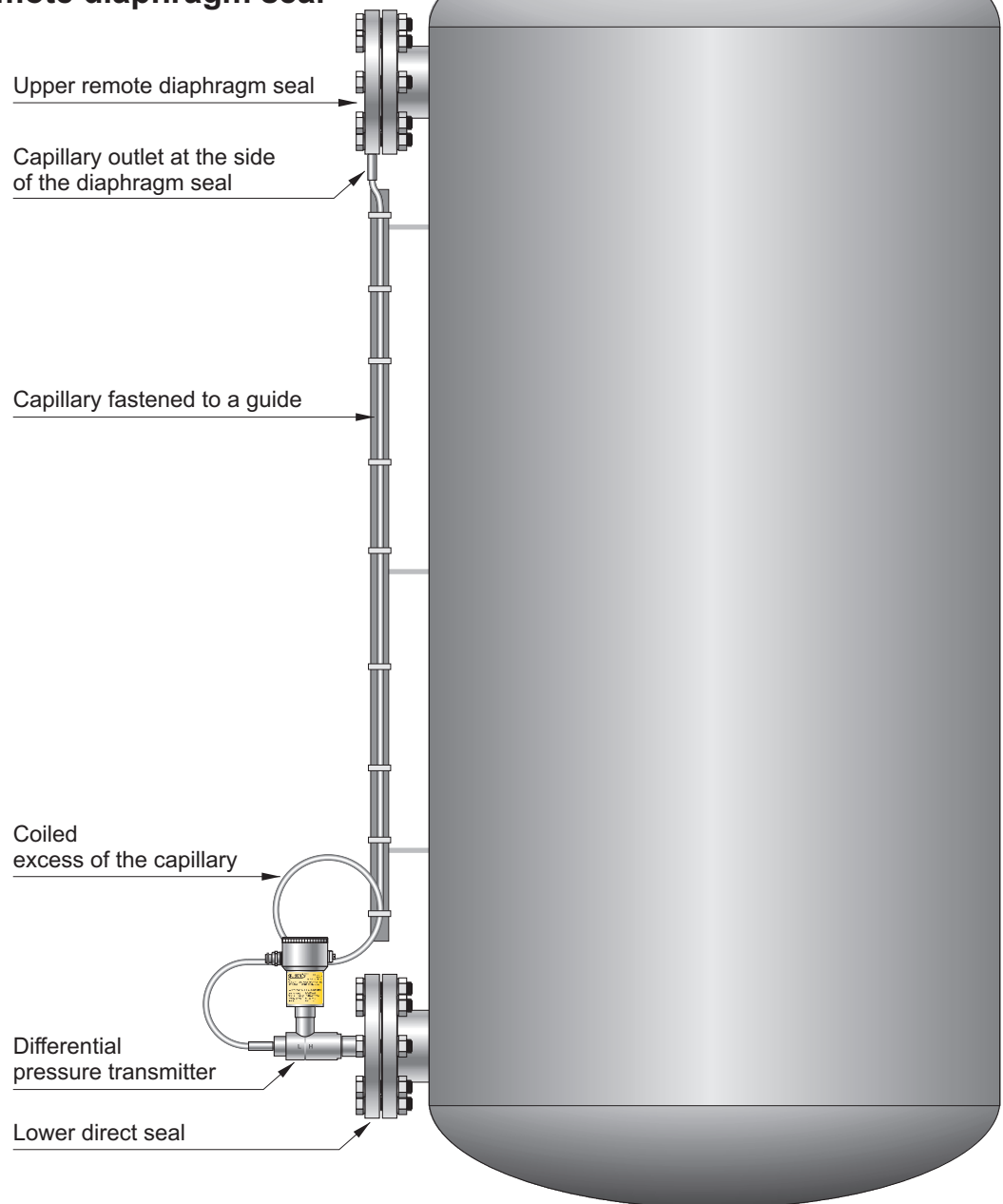

Example of measurement of the level in a pressure tank

Recommendations

The transmitter with a direct diaphragm seal (connected to the positive measurement chamber) and a remote diaphragm seal (connected to the negative chamber) is recommended for hydrostatic measurements of: levels, densities, phase boundaries and pressure differences (with differentiated height of pulse source points*).

In such a configuration, at ambient temperature changes, two opposite phenomena appear concurrently.

Thermal expansion causes the change in the volume (and hence also the change in density) of the manometric fluid in the capillary, which results in a change of the hydrostatic pressure related to the vertical spacing of the seals. This phenomenon is

counteracted by the elastic reaction of the diaphragm of the upper diaphragm seal, which is displaced by the change in volume of manometric fluid. Based on tests and experiments, the Aplisens transmitters are provided with carefully selected seal diaphragms, which guarantee compensation of the errors resulted from the ambient temperature changes.

The best metrological results are obtained using assembly, which include DN 80, DN 100, A 109 and S-Comp diaphragm seals or S-Mazut, S-DIN and S-Clamp diaphragm seals with a diameter of at least 65 mm, where the length of the capillary is $(1...1.3) \times$ (vertical spacing of seals). It is recommended using identical diaphragm seals at the both upper and lower connection points.

* The difference in height of pulse source points, at which the hydrostatic pressure of the manometric fluid is comparable to or greater than the range of the transmitter.

Example versions

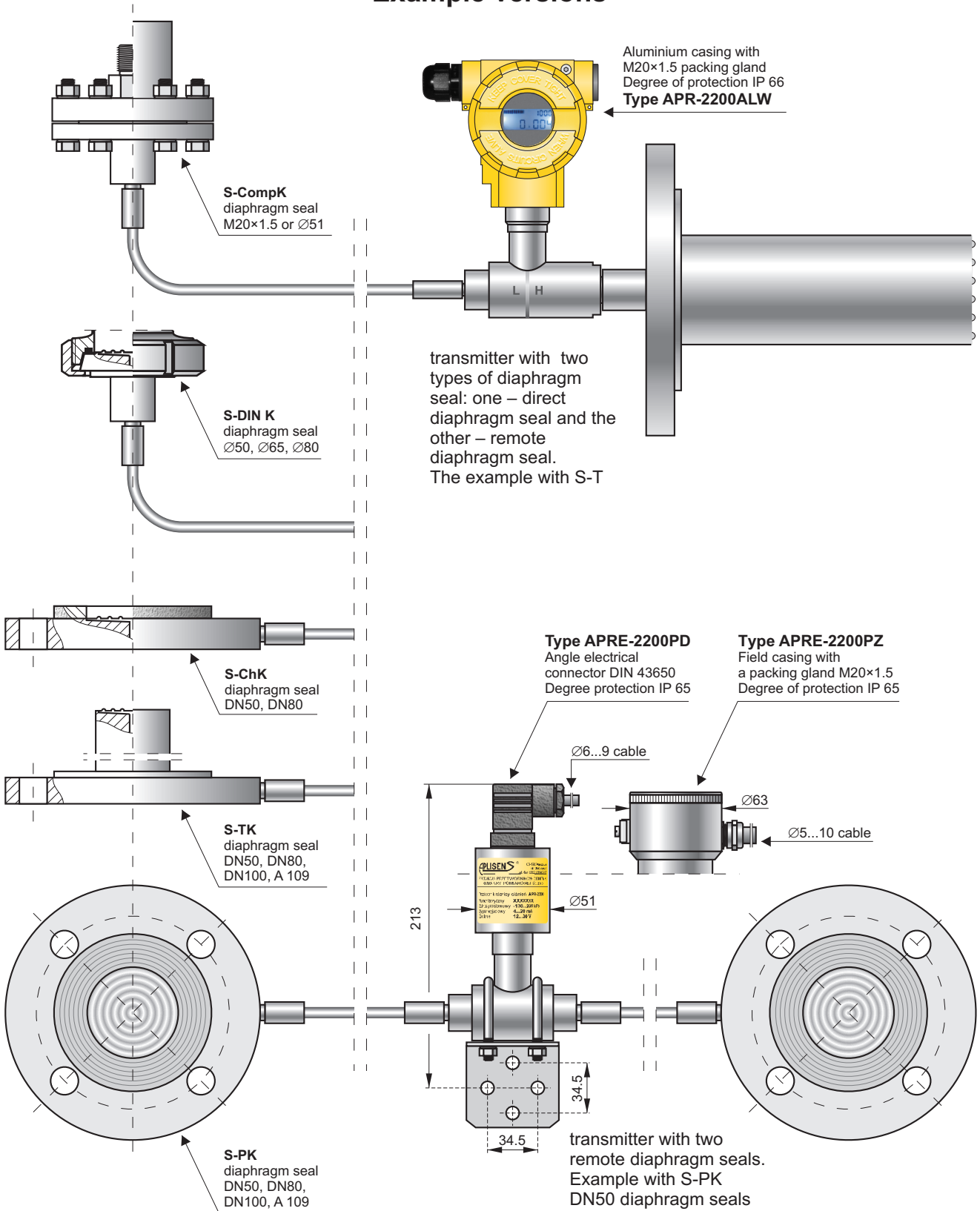

Note: The appropriate configuration of the complete set of pressure transmitter, diaphragm seals and capillaries, as well as the proper selection of manometric fluid, depends on several factors, including the physical and chemical properties, temperature range of the medium, the vertical spacing of the diaphragm seals, the measuring range, static pressure range, range of ambient temperatures and the technical specifications for mechanical connection of the diaphragm seals to the pressure devices.

Application and construction

The differential pressure transmitter is applicable to the measurement of pressure differences of: gases, vapours and liquids in cases where it is necessary to use seals and the pressure pulse source points may be several metres apart. Typical applications include the hydrostatic measurement of: levels in closed tanks, densities and phase boundaries, and the measurement of a filter loss, pressure differences between media in pasteurisers etc. The available range of the diaphragm seals allows measurement at great majority of media. The active element is a piezoresistant silicon sensor separated from the medium by a distance sealing system. The special design of the measuring unit means that it can withstand pressure surges and overloads of up to 40 bar. The electronic circuits are enclosed in a casing with a degree of protection IP 65 or IP66.

Configuration

The settings of the following metrological parameters can be changed:

- ♦ the units of pressure in which the range is configured,
- ♦ start and end points of the range, time constant,
- ♦ inverted characteristic (output signal 20 ± 4 mA).

Communication

The transmitter is configured and calibrated using a KAP-03 communicator, some other communicators (HART) or a PC using an RS-HART converter and Aplisens RAPORT-01 configuration software. Along with the RAPORT-01, the SECTIONAL LINEARIZATION software is supplied. The software enables leading of the 21-point, non-linear user's characteristic into the transmitter.

The data interchange with the transmitter enables the users the transmitter identification, as well as reading of the currently measured differential pressure value, output current and percent of range width.

Measuring ranges

Nominal measuring range (FSO)	Minimum set range	Vertical spacing of diaphragm seals	Maximum set range width, considering the actual vertical spacing of the diaphragm seals (m)	Static pressure limit
-160...160 mbar	0.1 m H ₂ O	≤ 1.7 m	[1.6 + (vertical spacing of seals × 0.94)] m H ₂ O	40 bar
-0.5...0.5 bar	0.5 m H ₂ O	≤ 6 m	[5 + (vertical spacing of seals × 1.04)] m H ₂ O	40 bar
-1.6...2 bar	1.5 m H ₂ O	≤ 15 m	[20 + (vertical spacing of seals × 1.04)] m H ₂ O	40 bar
-1.6...16 bar	1 bar	≤ 15 m	16 bar	40 bar

CAUTION: The maximum vertical diaphragm seal spacing shown in the table applies to level measurement, ensuring that it is possible to set the zero point of the transmitter when the tank is empty. For measurements of density or phase boundaries (in the sugar, chemical or refinery industries) the vertical spacing of the diaphragm seals can be larger.

Metrological parameters

Accuracy ≤ ±0.1% (FSO)

The other parameters as given in the sheet for the smart differential pressure transmitter APR-2000ALW/APRE-2000.

Sealing effect errors – as given in the relevant diaphragm seal sheet in chapter III (Diaphragm Seals), concerning the distance seal.

NOTE: The additional absolute zero error due to ambient temperature can be compensated by configuring the transmitter, seals and capillaries in accordance with the recommendations on pages 38 and 39.

Electrical parameters – as given in the sheet for the APR-2000ALW/APRE-2000 differential pressure transmitter.

Operating conditions

Operating temperature range (ambient temperature) -25...85°C
APR-2200ALW/Ex and APRE-2200/Ex -25...80°C

Medium temperature range – as given in the appropriate diaphragm seal sheet (remote seal)

Special versions, certificates:

EEexia – ATEX Intrinsic safety

EEExd – ATEX explosion proof

100 bar, 160 bar – static pressure limit – 100 bar or 160 bar

Non-standard basic range

Others

Electrical diagrams for transmitters with HART protocol

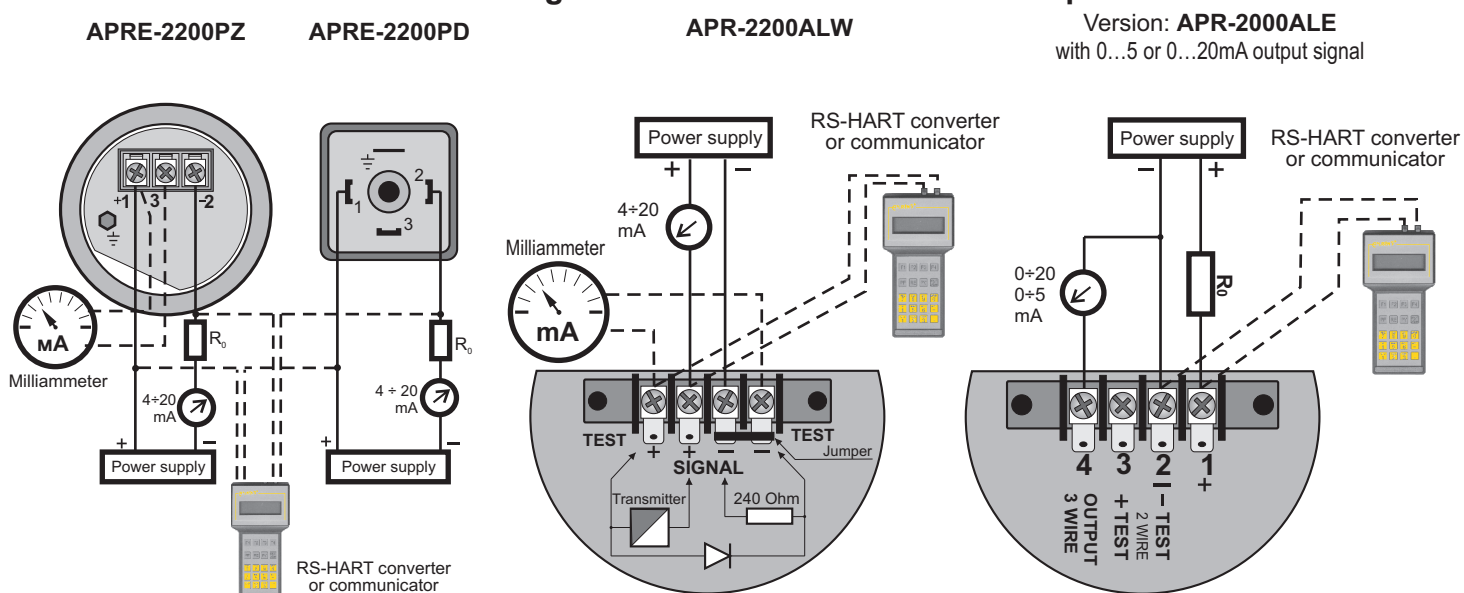

SMART DIFFERENTIAL PRESSURE TRANSMITTER APR-2200AL/Profibus PA/W

Construction

The transmitter electronic system performs the digital processing of measurement and generates the output signal with the communication module according to Profibus PA standard. The transmitter function performance bases on profile 3.0 of Profibus PA standard.

The casing is made of high-pressure casting of aluminium alloy, IP-65 rated. The casing design allows using a local liquid crystal graphical display, 90° turn of display, 0–355° turn of casing relative to the sensor, and the choice of direction at cable insertion.

The measuring ranges, according to the table, page 41.

Communication

The communication with the transmitter is achieved in two ways:

- ◇ cyclic – the transmitter sends primary measured value (4 bytes IEEE754) and status containing the information on the current state of transmitter and measurement validity (1 byte).
- ◇ acyclic – this way of communication is used to device configuration and to read both primary measured value and the status.

Configuration

Full configuration of transmitter settings, adjustment of the display mode, transmitter zeroing and calibration in relation to pressure standards proceeds with the PDM (Process Device Manager) software, by Siemens. The EED program library, worked out by Aplisens for cooperation with this transmitter, is helpful in the configuration.

Other commercial configuration software (e.g. Commuwin by Endress and Hauser, DTM/FDT tools) make transmitter configuration possible in the range of basic commands.

Enclosed to APR-2200AL/Profibus PA is GSD file comprising the description of the transmitter basic properties such as transmission rate, type and format of input data, list of additional functions. GSD file is necessary for the software serving as a device for network configuration and makes the correct connection the appliance to Profibus network possible. The universal file GSD, designed for standard pressure transmitters made according to profile at revision 3 Profibus standard, may also be applicable to APR-2200AL/Profibus PA.

The pressure transmitter APR-2200AL/Profibus PA does not have the hardware address switch This address may be adjusted with accessible configuration software.

Measurements in the areas under explosion hazard

For pressure measurements in the areas under explosion hazard the Atex intrinsically safe transmitters, are available

Metrological parameters

Accuracy $\leq \pm 0.1\%$ (FSO)

Other parameters: as for APR-2200ALW.

Sealing effect errors: as given on the relevant diaphragm seal sheet in chapter Diaphragm Seals, in relation to the distance seal

NOTE: The additional absolute zero error due to ambient temperature can be compensated by configuring the transmitter, diaphragm seals and capillaries in accordance with the recommendations on pages 38, 39.

Electrical parameters

Power supply (from DP/PA coupler)

10,5 \pm 28V DC

12.05 \pm 28V DC - when display illumination switched on

Power supply from intrinsically safe coupler according to FISCO requirements.

$V_i = 17,5VDC$

$I_i = 0,38A$ for IIB

$I_i = 0,36A$ for IIC

Current consumption

14mA

Output parameters

Output signal Digital communication signal Profibus – PA (according to EN 50170)

PA function slave

Physical layer IEC61158-2

Transmission range 31,25kBit/S

Modulation Manchester II

Operating conditions

Operating temperature range (ambient temp.): –25..85°C

EEx version: –25..65°C

Medium temperature range: as given on the appropriate diaphragm seal

Electrical diagrams

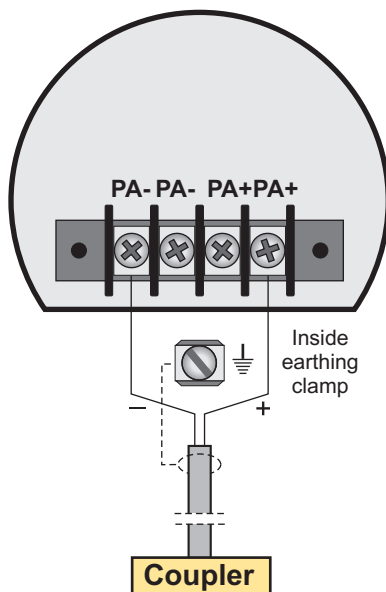

Ordering procedure

(See next page)

Examples:

Ordering code to APRE-2200:

Smart differential pressure transmitter APRE-2200, nominal measuring range -1,6 \pm 2 bar, on the (+) side a DN80 PN40 direct diaphragm seal, 100mm tube, on the (-) side a DN80 PN40 remote diaphragm seal, capillary length 8m.

APRE-2200PD / -1,6 \pm 2 bar/ (+) S-T DN80; T=100mm/ (-)S-PK DN80; K=8m

Ordering code to APR-2200ALW:

Smart differential pressure transmitter APR-2200ALW with display, nominal measuring range -0,5 \pm +0,5 bar, with two remote diaphragm seals, capillaries length 2x K=2,5m

APR-2200ALW / -0,5 \pm 0,5bar/ (+) S-PK DN80; K=2,5m/ (-)S-PK Dn80/ K=2,5m

Ordering code to APR-2200AL/ProfibusPA:

Smart differential pressure transmitter APR-2200AL/ProfibusPA, nominal measuring range -0,5 \pm +0,5 bar, with two remote diaphragm seals, capillaries length 2x K=2,5m

APR-2200AL/Profibus PA / -0,5 \pm 0,5/ (+) S-PK DN80; K=2,5m/ (-)S-PK DN80; K=2,5m

Ordering procedure APR-2200ALW



Model	Codes	Description	
APR-2200		Smart differential pressure transmitter.	
Casing, Output signal, ⇒	ALW.....	Aluminium housing, IP66, with display, output 4–20mA + Hart	
	ALE.....	Aluminium housing, IP66, with display, output 4–20mA + Hart 0 – 20mA+ Hart, 0 – 5mA+ Hart,	
	AL/Profibus PA.....	Aluminium housing, IP66, without display, output Profibus PA	
	AL/Profibus PA/W.....	Aluminium housing, IP66, with display, output Profibus PA	
	ALW/SS..... ...	316ss stainless steel housing, IP66, with display, output 4–20mA + Hart	
Versions, Certificates* *) more than one option is available	/EEx ia.....	Ex II 1/2G Exia IIC T5 (not available for ALE version)	
	/EEx d.....	Ex II 1/2G Exia/d IIC T5/T6 Ex II 1/2D ExiaD 20/TD A21T85/T100 (not available for ALE version)	
	/100bar.....	Static pressure limit – 100bar	
	/160bar.....	Static pressure limit – 160bar	
Nominal measuring range ⇒ (* not-standard ranges available on request)	-160+160mbar..... -0.5+0.5bar..... -1.6+2bar..... -1.6+16bar.....	Range	
		min set range	
		-160+160mbar (-16+16kPa)	0,1 mH ₂ O
		-0.5+0.5bar (-50+50kPa)	0,5mH ₂ O
		-1.6+2bar (-160+200kPa)	1,5mH ₂ O
-1.6+16bar (-160+1600kPa)	1bar		
Measuring set range	/...÷... [required units].....	Start and end of calibrated range in relation to 4mA and 20mA output	
Process connections	/(+).	Direct diaphragm seal or remote diaphragm seal mounted on the (+) side of the transmitter- code as given in the relevant diaphragm seal sheet	
	/(-).	Remote diaphragm seal mounted on the (-) side of the transmitter – code as given in the relevant diaphragm seal sheet (chapter III – seals)	
Electrical connection	⇒ (without marking).....	Packing gland M20x1,5	
	/US.....	Thread 1/2NPT Female	
Accessories	⇒ /F125.....	Mounting bracket type F125 for 2" pipe, material 304ss	
Other specification	/.....	Description of required parameters	

Ordering procedure APRE-2200

Model	Codes	Description	
APRE-2200		Smart differential pressure transmitter.	
Casing, Output signal, ⇒	PD.....	Housing IP65 with DIN43650 connector, without display, output 4–20mA +Hart, packing gland M20x1,5.	
	PZ.....	304SS housing, IP66, without display, output 4–20mA + Hart packing gland M20x1,5	
	PZ/316.....	304SS housing, IP66, without display, output 4–20mA + Hart	
Versions, Certificates* *) more than one option is available	/EExia.....	II 1/2G Ga/Gb Ex ia IIC T4/T5/T6 I M1 Ex ia I II 1D Ex iaD 20 T110°C	
	/100bar.....	Static pressure limit – 100bar	
	/160bar.....	Static pressure limit – 160bar	
Nominal measuring range ⇒ (* not-standard ranges available on request)	-160+160mbar..... -0.5+0.5bar..... -1.6+2bar..... -1.6+16bar.....	Range	
		min set range	
		-160+160mbar (-16+16kPa)	0,1 mH ₂ O
		-0.5+0.5bar (-50+50kPa)	0,5mH ₂ O
		-1.6+2bar (-160+200kPa)	1,5mH ₂ O
-1.6+16bar (-160+1600kPa)	1bar		
Measuring set range	/...÷... [required units].....	Start and end of calibrated range in relation to 4mA and 20mA output	
Process connections	/(+).	Direct diaphragm seal or remote diaphragm seal connected to the (+) side of the transmitter- code as given in the relevant diaphragm seal sheet	
	/(-).	Remote diaphragm seal connected to the (-) side of the transmitter – code as given in the relevant diaphragm seal sheet (chapter III – seals)	

To simplify the mathematical operations we introduce the density coefficient of the medium $X\rho$.

$$X\rho = \frac{\rho_{\text{medium}} [\text{g/cm}^3]}{\rho_{\text{water at 4}^\circ\text{C}} [\text{g/cm}^3]}$$

Since the density of water at 4°C is 1 g/cm³, the **density coefficient $X\rho$ is numerically equal to the density of the medium expressed in g/cm³**. To determine the hydrostatic pressure of a column of liquid in mm H₂O, it is sufficient to multiply the height of the column h [mm] by the density coefficient of the liquid $X\rho$. Since it is easy to determine the hydrostatic pressure in mm H₂O and the transmitter can be configured in those units, in the descriptions of measurement methods given below we will make use of pressures expressed in mm H₂O and the density coefficient $X\rho$.

Configuration of the transmitter to measure the level of liquid in a tank

The measurement task:

To convert a variation in the level of a liquid with density $\rho = 0.87 \text{ g/cm}^3$ between 0 and h_{max} to a variation in the output signal from 4 to 20 mA.

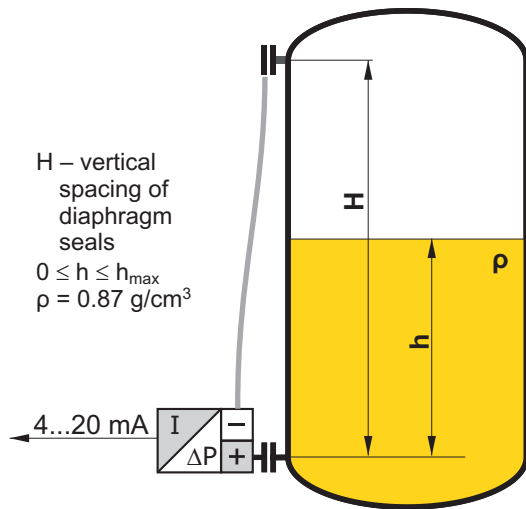

H – vertical spacing of diaphragm seals

$0 \leq h \leq h_{\text{max}}$
 $\rho = 0.87 \text{ g/cm}^3$

1. Install the transmitter in its working position on an empty tank.
2. Make the electrical connections of the transmitter, providing for the ability to use HART communication.
3. Connect the KAP-02 communicator, identify the transmitter and select the “configuration” function.

4. On the configuration menu select the “Reranging” procedure.
5. On the “Reranging” menu:
 - a) change the units of measurement to mm H₂O at 4°C;
 - b) enter the values for the start ($X\rho \times h_{\text{min}}$ [mm]) and end ($X\rho \times h_{\text{max}}$ [mm]) of the measurement range, namely 0 and ($0.87 h_{\text{max}}$ [mm]) respectively;
 - c) to compensate for the hydrostatic pressure of the manometric fluid, the start of the measurement range should be set using regulated pressure; when subject to the action of only the manometric fluid (empty tank) the transmitter will shift the start and end-points of the range, compensating for the value of that pressure.

When the transmitter has been configured in this way it is ready to be used to carry out the given measurement task.

If it is not possible to empty the tank to configure the transmitter, the hydrostatic pressure of the manometric fluid should be calculated by multiplying the vertical spacing of the diaphragm seals by the density coefficient of the oil in the capillaries. This pressure should be taken into account when entering the values for the start and end of the range:

$$\text{Start [mm H}_2\text{O]} = -H [\text{mm}] \times X\rho_{\text{oil}}$$

$$\text{End [mm H}_2\text{O]} = h_{\text{max}} [\text{mm}] \times X\rho_{\text{measured liquid}} - H [\text{mm}] \times X\rho_{\text{oil}}$$

ρ_{oil} for DC-550 oil is equal to 1.068 g/cm³
 ρ_{oil} for AK-20 oil is equal to 0.945 g/cm³

Configuration of the transmitter to measure density of liquids

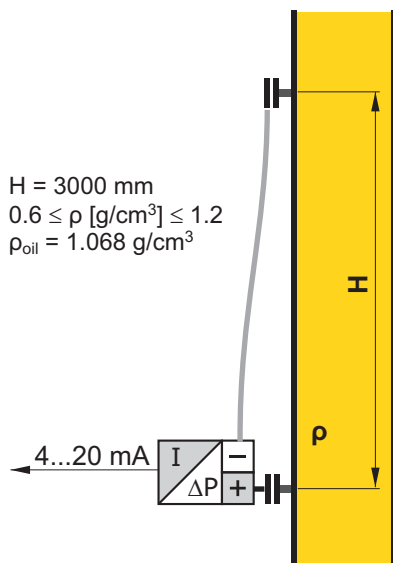

$H = 3000 \text{ mm}$
 $0.6 \leq \rho [\text{g/cm}^3] \leq 1.2$
 $\rho_{\text{oil}} = 1.068 \text{ g/cm}^3$

The measurement task:

To convert a variation in liquid density from $\rho_{\text{min}} = 0.6 \text{ g/cm}^3$ to $\rho_{\text{max}} = 1.2 \text{ g/cm}^3$ to a variation in the output signal from 4 to 20 mA, with the vertical spacing of the diaphragm seals equal to $H = 3000 \text{ mm}$. The sealing system is filled with DC-550 oil with density $\rho_{\text{oil}} = 1.068 \text{ g/cm}^3$.

1. Calculate the value of the start of the range as follows:
 $H_{[\text{mm}]} \times (X\rho_{\text{min}} - X\rho_{\text{oil}}) = 3000 \times (0.6 - 1.068) = -1404 [\text{mm H}_2\text{O}]$
2. Calculate the value of the end of the range as follows:
 $H_{[\text{mm}]} \times (X\rho_{\text{max}} - X\rho_{\text{oil}}) = 3000 \times (1.2 - 1.068) = 396 [\text{mm H}_2\text{O}]$
3. Set the zero point of the transmitter with the diaphragm seals positioned at the same level.
4. Install the transmitter in its working position.
5. Make the electrical connections to the transmitter, providing for the possibility of using HART communication.

6. Connect the KAP-02 communicator, identify the transmitter and select the "configuration" function.
7. On the configuration menu select "Reranging" procedure.
8. On the "Reranging" menu:
 - a) change the measurement units to mm H₂O at 4°C;
 - b) enter the calculated values for the start (-1404) and end (396) of the range.

When the transmitter has been configured in this way it is ready to be used to carry out the given measurement task.

Note: If it is possible to fill the space between the seals with a liquid whose density corresponds to the start of the measurement range, the start of the range of the transmitter can be set using regulated pressure.

Measurement of phase boundary

The height of the phase boundary of liquids of different densities is determined by measuring the average density of the medium between the seals.

Example:

Calculate the measurement range start and end points for an APRE-2200 transmitter configured to measure phase boundary height in the range 0–1000 mm between liquids of density $\rho_1 = 0.7 \text{ g/cm}^3$ and $\rho_2 = 1.0 \text{ g/cm}^3$, where the vertical spacing of the seals $H = 1600 \text{ mm}$. The sealing system uses DC-550 oil with a density of 1.068 g/cm^3 .

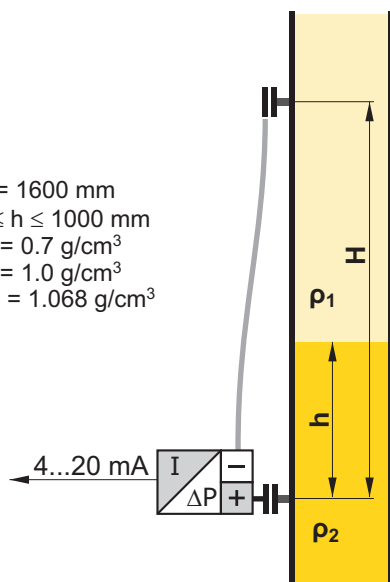

To determine the start of the measurement range, calculate the pressure difference at the transmitter when the tank is filled with the lighter liquid only:

$$1600 \text{ [mm]} \times (0.7 - 1.068) = -588.8 \text{ [mm H}_2\text{O]}$$

To determine the end-point of the range, add the increase in pressure resulting from the appearance of a 1 metre column of the heavier liquid:

$$-588.8 \text{ [mm H}_2\text{O]} + (1.0 - 0.7) \times 1000 \text{ [mm]} = -288.8 \text{ [mm H}_2\text{O]}$$

Additional remarks

The settings of the transmitter can be adjusted with reference to laboratory results from density measurements carried out on samples of the liquid being measured. This is most often necessary when the measurement takes place in a pipeline segment where the flow velocity of the measured liquid reaches several m/s.

Increasing the vertical spacing of the diaphragm seals widens the range and often improves measurement accuracy.

In planning the spacing of the diaphragm seals, ensure that the pressure difference at the transmitter lies within the basic range.

The maximum vertical spacing of the diaphragm seals (H) depends on the transmitter's basic range and the boundary values for the density of the measured liquid (ρ_{\min} ; ρ_{\max}).

If $\rho_{\min} < \rho_{\text{oil}} < \rho_{\max}$, the seal spacing H should satisfy the following conditions:

$$H \text{ [mm]} \leq \frac{\text{lower boundary of range [mm H}_2\text{O]}}{X\rho_{\min} - X\rho_{\text{oil}}}$$

$$H \text{ [mm]} \leq \frac{\text{upper boundary of range [mm H}_2\text{O]}}{X\rho_{\max} - X\rho_{\text{oil}}}$$

Example:

Determine the maximum vertical spacing of the seals for the **APRE-2200 / -10...10 kPa** transmitter when measuring the density of liquid between 0.6 and 1.2 g/cm^3 . The sealing system uses AK-20 silicone oil with a density of 0.945 g/cm^3 .

The lower boundary of the range of the transmitter is $-10 \text{ kPa} = -1020 \text{ mm H}_2\text{O}$

$$H \text{ [mm]} \leq \frac{-1020}{0.6 - 0.945} \Rightarrow H \text{ [mm]} \leq \frac{-1020}{-0.345} \Rightarrow H \text{ [mm]} \leq 2957$$

The upper boundary of the range of the transmitter is $+10 \text{ kPa} = 1020 \text{ mm H}_2\text{O}$

$$H \text{ [mm]} \leq \frac{1020}{1.2 - 0.945} \Rightarrow H \text{ [mm]} \leq \frac{1020}{0.255} \Rightarrow H \text{ [mm]} \leq 4000$$

In the example, both conditions are satisfied when the spacing of the seals is not more than 2957 mm.