

# Smart differential pressure transmitter for low ranges APR-2000GALW

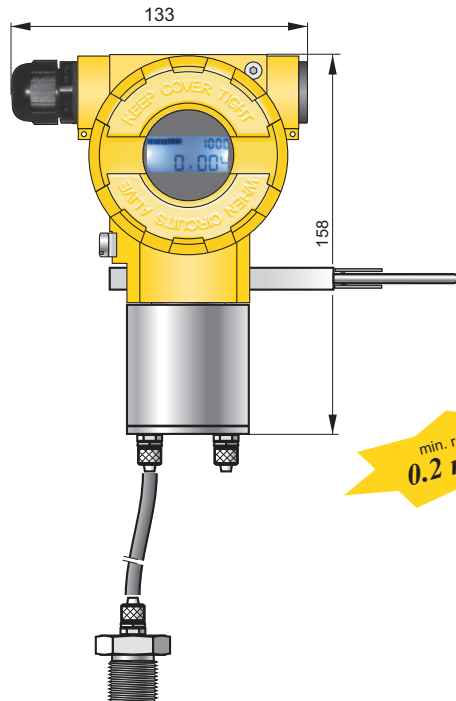

APR-2000GALW Economic Version, process connection with terminal connecting to  $\varnothing 6$  pipe (**PCV type**)

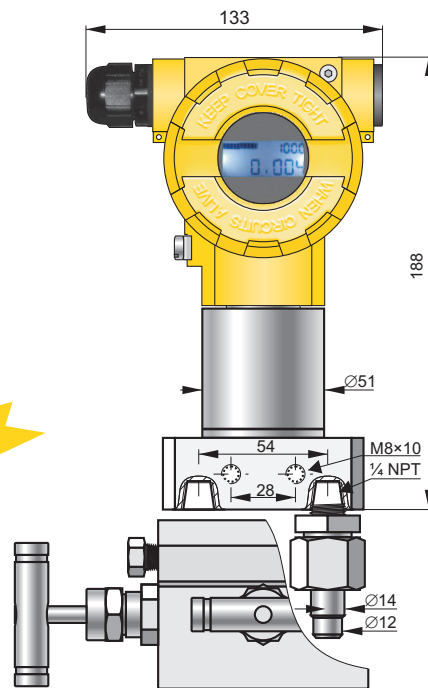

APR-2000GALW Industrial Version, **C type** process connector to be mounted along with a valve manifold

- ✓ Digital PROFIBUS PA signal
- ✓ 4...20 mA output signal + HART protocol
- ✓ Programmable range, zero shift, damping ratio and Characteristic with local panel keys
- ✓ Selectable linear or radical conversion characteristic
- ✓ Accuracy from 0.1%
- ✓ ATEX Intrinsic safety **NEW**

## Application

The APR-2000GALW transmitter is applicable to gases, to the measurements of their pressure, underpressure and differential pressure. Typical applications include the measurement of blast pressure, chimney draughts or pressure / underpressure in furnace chambers. The ability to select the radical conversion characteristics enables the transmitter to be used in gas-flow measurement systems using reducing pipes or other impeding elements. The transmitter can withstand overpressure up to 1 bar. The housing of the electronic circuit has the degree of protection IP66.

## Configuration, calibration

The following metrological parameters can be configured:

- ◆ The units of pressure,
- ◆ Start and end-points of measuring range, damping time constant,
- ◆ Conversion characteristic (radical, inversion, user's non-linear characteristic).

Ability to calibrate the transmitter with reference to a standard pressure.

## Communication

Communication with the transmitter is carried out with a KAP-03 communicator, some other Hart communicators or a PC with an RS-HART converter and RAPORT-01 configuration software.

Additionally, the data interchange with the transmitter enables the users to identify the transmitter, read the currently measured pressure difference value, output current and percentage of measuring range.

## Installation

The economical version can be mounted on any stable construction using the assembly fixture with  $\varnothing 9$  opening. The transmitter's connection shanks have terminals to be connected to the elastic  $\varnothing 6 \times 1$  impulse line. Where the pulse comes through a metal pipe, we suggest an M20 $\times$ 1.5 adapter for a  $\varnothing 6 \times 1$  fitting using.

The transmitter with a C type connector should be mounted on a 3- or 5-valve manifold. We recommend the use of our pre-assembled transmitters with VM type valves (page 62).

## Operating guidelines

The transmitter should be mounted in a vertical position. The impulse lines should be connected in such a way that any condensed liquids could flow off away from the device.

Where there is a significant difference in height between the place where the transmitter is mounted and the place where the pulse is taken, the measurement may vary with the temperature of the impulse line. Connecting a compensating pipe close to the impulse line, from the transmitter's reference connection shank to the height at which the impulse is taken can minimise this effect.

To prevent dust from entering the measuring cells, the impulse lines should be attached with care, with particular attention to the tightness of the connections between the impulse lines and the transmitter.

## Measuring ranges

Nominal measuring range (FSO)	Minimum set range	Overpressure limit	Static pressure limit
0...25 mbar (0...2500 Pa)	1 mbar (100 Pa)	1 bar	350 mbar
-2.5...2.5 mbar (-250...250 Pa)	0.2 mbar (20 Pa)	350 mbar	350 mbar
-7...7 mbar (-700...700 Pa)	1 mbar (100 Pa)	350 mbar	350 mbar
-25...25 mbar (-2500...2500 Pa)	5 mbar (500 Pa)	1 bar	1 bar
-100...100 mbar (-10...10 kPa)	20 mbar (2 kPa)	1 bar	1 bar

## Meteorological parameters

Nominal range	0...25 mbar	-2.5...2.5 mbar	-7...7 mbar	-25...25 mbar	-100...100 mbar
Accuracy	0.075%	0.16%	0.1%	0.1%	0.075%

**Thermal error**  $\leq \pm 0.1\%$  (FSO) / 10°C  
max.  $\pm 0.4\%$  (FSO) in the whole compensation temperature range

**Thermal compensation range** -10...70°C

**Additional electronic damping** 0...60 s

**Error due to supply voltage changes** 0.002% (FSO) / V

### Electrical parameters

**Power supply** 12...55 V DC (EEx 13,5...28 V)

**Additional voltage drop when display illumination switched on** 3V

**Output signal** 4...20 mA, two wire transmission

**Load resistance**  $R[\Omega] \leq \frac{U_{sup}[V] - 12 V^*}{0,02A} \cdot 0,85$

\*-15 when display illumination switched on

**Resistance required for communication** 250...1100  $\Omega$

### Operating conditions

Operating temperature range (ambient temp.) -25...85°C

### Materials

Materials:

casing	Aluminium
option:	316ss
adapter C type	316ss
adapter PCV type (on $\varnothing 6$ elastic pipe)	brass
valve manifold	316ss

Version: APR-2000GALW

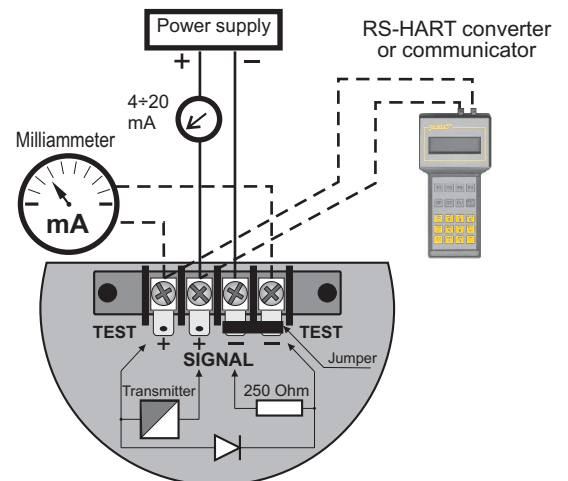

## Ordering procedure

Model	Code	Description
APR-2000G		Smart differential pressure transmitter.
Casing, output signal,	⇒ ALW..... AL/Profibus PA..... AL/Profibus PA/W..... ALW/SS.....	Aluminium housing, IP66, with display, output 4–20mA + Hart Aluminium housing, IP66, without display, output Profibus PA Aluminium housing, IP66, with display, output Profibus PA 316ss stainless steel housing, IP66, with display, output 4 - 20mA + Hart
Certificate	/EExia.....	Ex II 1/2G Ex ia IIC T4/ T5 (only Hart version)
Nominal measuring range	/0÷25mbar.....	0÷25mbar (0÷2500Pa)      1mbar (100Pa)
	/-2.5÷2.5mbar.....	-2.5÷2.5mbar (-250÷250Pa)      0,2 mbar (20Pa)
	/-7÷7mbar.....	-7÷7mbar (-700÷700Pa)      1mbar (100Pa)
	/-25÷25mbar.....	-25÷25mbar (-2500÷2500Pa)      5mbar (500Pa)
	/-100÷100mbar.....	-100÷100mbar (-10÷10kPa)      20mbar (2kPa)
Measuring set range	/...÷... [ required units]	Start and end of calibrated range in relation to 4mA and 20mA output
Process connections	⇒ /PCV.....	Process connection with terminal connecting for Ø6mm elastic pipe. Mounting bracket for wall mounting is a standard.
	/C.....	Thread 1/4 NPT F on cover flange. Material of cover flange SS316L. Allows mounting with a valve manifold.
Electrical connection	⇒ (without marking).....	Packing gland M20x1,5
	/US.....	Thread 1/2NPT Female
Accessories**	⇒ /AL.....	Mounting bracket type AL for 2" pipe, material zincd steel
	/M20x1,5/Ø6.....	Adapters from Ø6mm elastic pipe for M20x1,5 M thread (only version with PCV process connection)
	/RedSpaw C.....	Connector to weld impulse pipes dia. 12 and 14 mm, material 15HM. Only process connection C type.
	/+VM-3/A.....	Assembled with a 3- way valve manifold ( further specification of manifold- see data sheet) . Only version with C type process connection.
**): more than one option is available	/+VM-5/A.....	Assembled with a 5- way valve manifold ( further specification of manifold- see data sheet) Only version with C type process connection.
Other specification	/.....	Description of required parameters
The most typical specification is marked by "⇒" mark.		

**Example 1:** Differential pressure transmitter with display, nominal range -7÷7mbar, set range -0,5÷1mbar, PCV type process connection, two additional M20x1,5/Ø6x1 adapters.

**APR-2000GALW/ -7÷7mbar/-0,5÷1mbar/PCV/ 2x M20x1,5/Ø6x1**

**Example 2:** Differential pressure transmitter with display, nominal range 0÷25mbar, set range 0÷4 mbar, C type process connection, mounted with a 3- ways valve manifold.

**APR-2000GALW/ 0÷25mbar/0÷4mbar/C/VM-3/A**