

Smart differential pressure transmitter for low ranges APRE-2000G

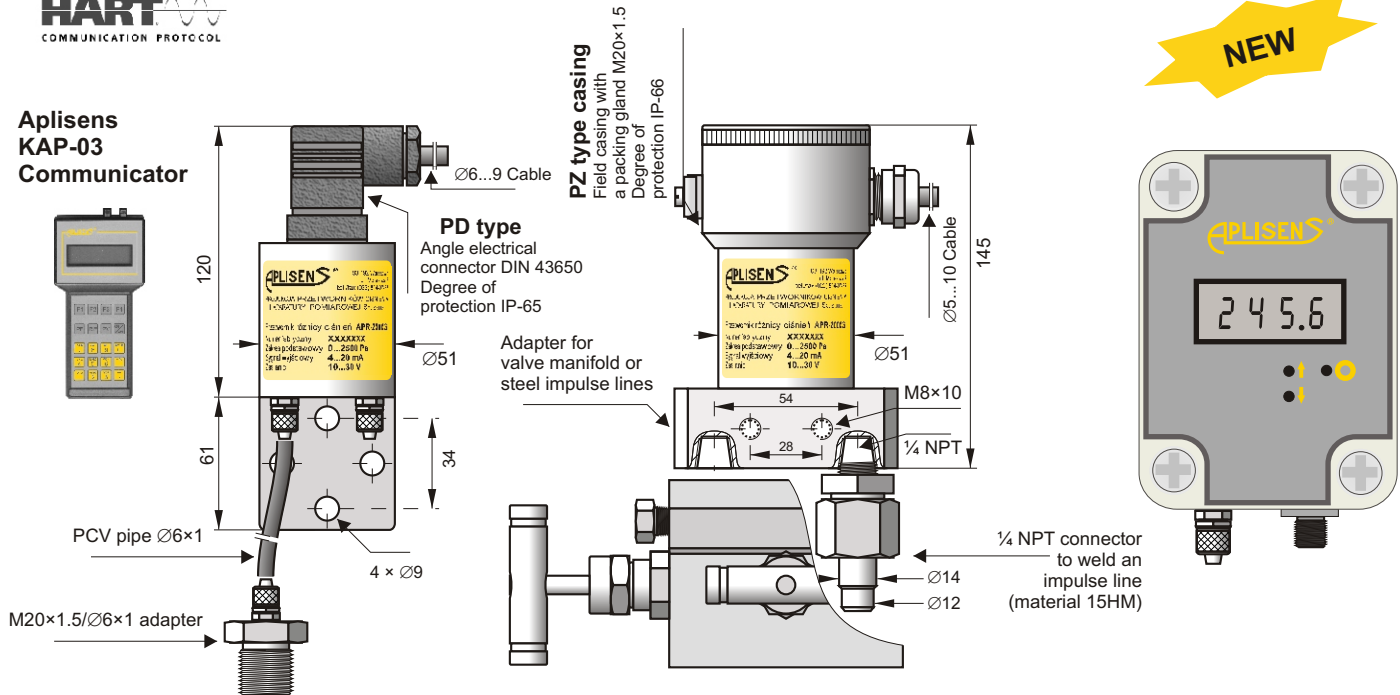

Aplisens KAP-03 Communicator



- ✓ Programmable range, zero shift, damping ratio and characteristic
- ✓ 4...20 mA output signal + HART protocol
- ✓ Accuracy from 0.1%
- ✓ ATEX Intrinsic safety (only APRE-2000G/PD, APRE-2000G/PZ)

Application

The APRE-2000G transmitter is applicable to gases, to the measurements of their pressure, underpressure and differential pressure. Typical applications include the measurement of blast pressure, chimney draughts or pressure / underpressure in furnace chambers. The ability to select the radical conversion characteristics enables the transmitter to be used in gas-flow measurement systems using reducing pipes or other impeding elements. The transmitter can withstand overpressure up to 1 bar. The housing of the electronic circuit has the degree of protection IP65 and IP66.

Configuration, calibration

The following metrological parameters can be configured:

- ◆ The units of pressure,
- ◆ Start and end-points of measuring range, damping time constant,
- ◆ Conversion characteristic (radical, inversion, user's non-linear characteristic).

Ability to calibrate the transmitter with reference to a standard pressure.

Communication

Communication with the transmitter is carried out with a KAP-03 communicator, some other Hart communicators or a PC with an RS-HART converter and RAPORT-01 configuration software.

Additionally, the data interchange with the transmitter enables the users to identify the transmitter, read the currently measured pressure difference value, output current and percentage of measuring range.

Installation

The economical version can be mounted on any stable construction using the assembly fixture with $\varnothing 9$ opening. The transmitter's connection shanks have terminals to be connected to the elastic $\varnothing 6 \times 1$ impulse line. Where the pulse comes through a metal pipe, we suggest an M20x1.5 adapter for a $\varnothing 6 \times 1$ fitting using.

The transmitter with a C type connector should be mounted on a 3- or 5-valve manifold. We recommend the use of our pre-assembled transmitters with VM type valves (page 62).

Operating guidelines

The transmitter should be mounted in a vertical position. The impulse lines should be connected in such a way that any condensed liquids could flow off away from the device.

Where there is a significant difference in height between the place where the transmitter is mounted and the place where the pulse is taken, the measurement may vary with the temperature of the impulse line. Connecting a compensating pipe close to the impulse line, from the transmitter's reference connection shank to the height at which the impulse is taken can minimise this effect.

To prevent dust from entering the measuring cells, the impulse lines should be attached with care, with particular attention to the tightness of the connections between the impulse lines and the transmitter.

Measuring ranges

Nominal measuring range (FSO)	Minimum set range	Overpressure limit	Static pressure limit
0...25 mbar (0...2500 Pa)	1 mbar (100 Pa)	1 bar	350 mbar
-2.5...2.5 mbar (-250...250 Pa)	0.2 mbar (20 Pa)	350 mbar	350 mbar
-7...7 mbar (-700...700 Pa)	1 mbar (100 Pa)	350 mbar	350 mbar
-25...25 mbar (-2500...2500 Pa)	5 mbar (500 Pa)	1 bar	1 bar
-100...100 mbar (-10...10 kPa)	20 mbar (2 kPa)	1 bar	1 bar

Metrological parameters

Nominal range	0...25 mbar	-2.5...2.5 mbar	-7...7 mbar	-25...25 mbar	-100...100 mbar
Accuracy	0.075%	0.16%	0.1%	0.1%	0.075%
Set range	0...2.5 mbar	-0.5...0.5 mbar	-0.5...0.5 mbar	-2.5...2.5 mbar	-10...10 mbar
Accuracy	0.4%	1%	1.6%	0.4%	0.4%

Thermal error $\leq \pm 0.1\%$ (FSO) / 10°C
max. $\pm 0.4\%$ (FSO) in the whole compensation temperature range

Thermal compensation range -10...70°C

Time Constant 0,3 s

Additional electronic damping 0...60 s

Error due to supply voltage changes 0.002% (FSO) / V

Electrical parameters

Power supply

APRE-2000G/PD and PZ: 10.5...36 V DC (EEx 12...28 V)
APRE-2000G/N: 12...36V DC

Additional voltage drop when display illumination switched on 3V

Output signal 4...20 mA, two wire transmission

Load resistance $R[\Omega] \leq \frac{U_{sup}[V] - 10.5V}{0,02A} - 0.85$

Resistance required for communication 240...1100 Ω

Operating conditions

Operating temperature range (ambient temp.) -25...85°C

Materials

APRE-2000G/PD and PZ
Materials: casing 304ss
adapter C type 316ss
adapter PCV type (on $\varnothing 6$ elastic pipe) brass
valve manifold 316ss

APRE-2000G/N
Materials: casing plastic box

Electrical diagram

APRE-2000G/N APRE-2000G/PZ APRE-2000G/PD

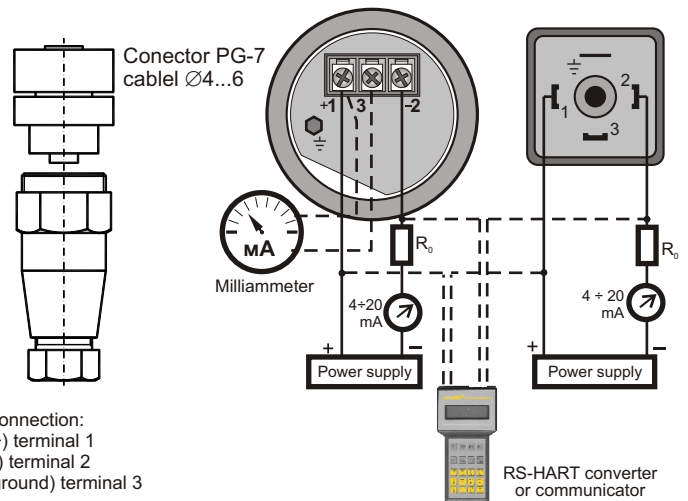

Ordering procedure

Model	Code	Description
APRE-2000G		Smart differential pressure transmitter.
Certificate	/EExia.....	Ex II 1/2G Exi IIC T4/T5/T6, Ga/Gb Exia IIC T4/T5/T6 and I M1 EExia I
Casing, Output signal, ⇒	/PD..... /PZ..... /N.....	Housing IP65 with DIN43650 connector, without display, output 4–20mA +Hart. 304SS housing, Ip66, without display, output 4 –20mA + Hart packing gland M20x1,5 Housing IP65, electrical connector PG-7 (version without ATEX),
Nominal measuring range		Range
	/0÷25mbar.....	0÷25mbar (0÷2500Pa)
	/-2.5÷2.5mbar.....	-2.5÷2.5mbar (-250÷250Pa)
	/-7÷7mbar.....	-7÷7mbar (-700÷700Pa)
	/-25÷25mbar.....	-25÷25mbar (-2500÷2500Pa)
		Min set range
	/-100÷100mbar.....	20mbar (2kPa)
Measuring set range	/..... [required units].....	Start and end of calibrated range in relation to 4mA and 20mA output
Process connections ⇒	/PCV.....	Process connection with terminal connecting for Ø6mm elastic pipe Mounting bracket for wall mounting is a standard.
	/C.....	Thread 1/4 NPT F on cover flange. Material of cover flange SS316L. Allows mounting with a valve manifold. Not available for APRE-2000G/N
Accessories** ⇒	/M20x1,5/Ø6.....	Adapter from Ø6mm elastic pipe for M20x1,5 M thread (only version with PCV process connection)
	/RedSpaw C.....	Connector to weld impulse pipes dia. 12 and 14 mm, material 15HM. Only process connection C type.
	/+VM-3/A.....	Assembled with a 3- way valve manifold (further specification of manifold- see data sheet) . Only version with C type process connection.
	/+VM-5/A.....	Assembled with a 5- way valve manifold (further specification of manifold- see data sheet) Only version with C type process connection.
**) more than one option is available		
Other specification	/.....	Description of required parameters
The most typical specification is marked by "⇒" mark.		

Example1: Differential pressure transmitter , nominal measuring range –7...7mbar, stainless steel casing, calibrated – 0,5..1mbar, process connection PCV to elastic pipe Ø6mm plus two adapters from elastic pipe Ø6mm for M20x1.5 M thread

APRE-2000G/PZ/-7÷7mbar/-0,5÷1mbar/PCV/ M201.5/Ø6 (x2)

Example2: Differential pressure transmitter , EExia version, nominal measuring range 0..25mbar, housing with DIN43650 connector, calibrated 0..10mbar, process connection C, mounted with a 3-ways valve manifold.

APRE-2000G/EEx/PD/0..25mbar/0..10mbar/C/VM-3/A

Example3: Differential pressure transmitter , nominal measuring range –7...7mbar, calibrated 0...7mbar , process connection PCV to elastic pipe Ø6mm, wall mounted version.

APRE-2000G/N/-7÷7mbar/0 ÷7mbar/PCV/ M201.5/Ø6 (x2)