

APLISENS

MANUFACTURE OF PRESSURE TRANSMITTERS
AND CONTROL INSTRUMENTS

USER'S MANUAL

SMART PRESSURE TRANSMITTER
type: **APC-2000ALW**





SMART DIFFERENTIAL PRESSURE TRANSMITTER
type: **APR-2000ALW, APR-2200ALW, APR-200GALW**

SMART LEVEL PROBE
type: **APR-2000YALW**

Edition E

WARSAW SEPTEMBER 2011

Symbols used

Symbol	Description
	Warning to proceed strictly in accordance with the information contained in the documentation in order to ensure the safety and full functionality of the device.
	Information particularly useful during installation and operation of the device.
	Information particularly useful during installation and operation of a type Ex device.
	Information on disposal of used equipment

BASIC REQUIREMENTS AND SAFE USE



- **The manufacturer will not be liable for damage resulting from incorrect installation, failure to maintain the device in a suitable technical condition, or use of the device other than for its intended purpose.**
- Installation should be carried out by qualified staff having the required authorizations to install electrical and pressure-measuring devices. The installer is responsible for performing the installation in accordance with these instructions and with the electromagnetic compatibility and safety regulations and standards applicable to the type of installation.
- The device should be configured appropriately for the purpose for which it is to be used. Incorrect configuration may cause erroneous functioning, leading to damage to the device or an accident.
- In systems with pressure transmitters there exists, in case of leakage, a danger to staff on the side where the medium is under pressure. All safety and protection requirements must be observed during installation, operation and inspections.
- If a device is not functioning correctly, disconnect it and send it for repair to the manufacturer or to a firm authorized by the manufacturer.



- In order to minimize the risk of malfunction and associated risks to staff, the device is not to be installed or used in particularly unfavourable conditions, where the following dangers occur:
- possibility of mechanical impacts, excessive shocks and vibration;
 - excessive temperature fluctuation, exposure to direct sunlight;
 - condensation of water vapour, dust, icing.



Installation of intrinsic safety versions should be performed with particular care, in accordance with the regulations and standards applicable to that type of installation.

The manufacturer reserves the right to make changes (not having a negative impact on the operational and metrological parameters of the products) without updating the contents of the technical manual.

CONTENTS

I.	APPENDIX Exd	2
II.	APPENDIX Exi	5
1.	INTRODUCTION	8
2.	USER MATERIALS	8
3.	APPLICATIONS AND MAIN FEATURES	8
4.	IDENTIFYING MARKS. ORDERING PROCEDURE	9
5.	TECHNICAL DATA	9
	5.1. APC... APR... - COMMON PARAMETERS	9
	5.2. APC... - MEASUREMENT RANGES AND METROLOGICAL PARAMETERS	12
	5.3. APR-2000ALW, APR-2200ALW MEASUREMENT RANGES AND METROLOGICAL PARAMETERS	13
	5.4. APR-2000GALW. MEASUREMENT RANGES AND METROLOGICAL PARAMETERS	14
	5.5. APR-2000YALW. MEASUREMENT RANGES AND METROLOGICAL PARAMETERS	14
6.	CONSTRUCTION	15
	6.1. MEASUREMENT PRINCIPLES, ELECTRONIC SYSTEM	15
	6.2. CONSTRUCTION	15
7.	PLACE OF INSTALLATION	16
	7.1. GENERAL RECOMMENDATIONS	16
	7.2. LOW AMBIENT TEMPERATURE	16
	7.3. HIGH MEDIUM TEMPERATURE	16
	7.4. MECHANICAL VIBRATION, CORROSIVE MEDIA	17
8.	INSTALLATION AND MECHANICAL CONNECTIONS	17
	8.1. APC... INSTALLATION AND CONNECTIONS	17
	8.2. APR... INSTALLATION AND CONNECTIONS	17
	8.3. APR-2000GALW. INSTALLATION AND CONNECTIONS	17
	8.4. APR-2000YALW. INSTALLATION AND CONNECTIONS	18
9.	ELECTRICAL CONNECTION	18
	9.1. GENERAL RECOMMENDATIONS	18
	9.2. ELECTRICAL CONNECTIONS FOR APC... APR...	18
	9.3. PROTECTION FROM EXCESS VOLTAGE	18
	9.4. EARTHING	19
10.	SETTING AND REGULATION	19
	10.1. TRANSMITTER RANGE BASIC RANGE. DEFINITIONS	19
	10.2. CONFIGURATION AND CALIBRATION	19
11.	INSPECTIONS AND SPARE PARTS	33
	11.1. PERIODIC SERVICE	33
	11.2. PERIODIC SERVICES	33
	11.3. CLEANING THE DIAPHRAGM SEAL, OVERLOADING DAMAGE	34
	11.4. SPARE PARTS	34
12.	PACKING, STORAGE AND TRANSPORT	34
13.	GUARANTEE	34
14.	ADDITIONAL INFORMATION	34
	14.1. RELATED DOCUMENTS	34
15.	FIGURES	35
	FIG. 1. APC...APR... TRANSMITTERS – BLOCK DIAGRAM	35
	FIG.2. ELECTRICAL CONNECTIONS FOR APC...APR... TRANSMITTERS	35
	FIG. 3. APC-2000ALW SMART PRESSURE TRANSMITTER	37
	FIG. 4. APC... APR... DISPLAY ROTATION POSSIBILITY, CONFIGURATION BUTTONS	38
	FIG. 5. M-TYPE CONNECTOR WITH M20x1.5 THREAD	39
	FIG. 6. P-TYPE CONNECTOR WITH M20x1.5 THREAD	39
	FIG. 7. CM30x2-TYPE CONNECTOR WITH FLUSH DIAPHRAGM WITH M30x2 THREAD	39
	FIG. 8. PROCESS CONNECTIONS G1/2" AND G1"	40
	FIG. 9. APR-2000ALW DIFFERENTIAL PRESSURE TRANSMITTER WITH C TYPE VENTED COVERS	41
	FIG. 10. APR-2000ALW DIFFERENTIAL PRESSURE TRANSMITTER WITH A SINGLE DIRECT DIAPHRAGM SEAL (EXAMPLE)	41
	FIG. 11. EXAMPLE: HOW TO INSTALL THE APR-2200ALW TRANSMITTERS WITH REMOTE DIAPHRAGM	42
	FIG. 12. EXAMPLE: HOW TO INSTALL THE APR-2000ALW TRANSMITTER ON A VERTICAL OR HORIZONTAL PIPE	43
	FIG. 13. EXAMPLE: HOW TO INSTALL THE APR-2000ALW TRANSMITTER WITH A VALVE MANIFOLD TO A 2" PIPE	43
	FIG. 14. APR-2200ALW DIFFERENTIAL PRESSURE TRANSMITTER WITH TWO REMOTE DIAPHRAGM SEALS (EXAMPLES)	44
	FIG. 15. APR-2200ALW DIFFERENTIAL PRESSURE TRANSMITTER WITH DIRECT AND REMOTE DIAPHRAGM SEAL (EXAMPLES)	44
	FIG. 16. EXAMPLE: HOW TO INSTALL THE APC... APR... TRANSMITTER	45
	FIG. 17. APR-2000GALW SMART DIFFERENTIAL PRESSURE TRANSMITTER FOR LOW RANGES	45
	FIG. 18. APR-2000YALW SMART LEVEL PROBE FOR PRESSURE TANKS	46
	FIG. 19. THE EXPLOSION - PROOF JOINTS OF APC...APR... TRANSMITTERS	47
	FIG. 20. HOW TO LEAD THE CASING OF APC...APR... TRANSMITTERS	47
	FIG. 21. ADDITIONAL EQUIPMENT FOR FITTING OF PRESSURE TRANSMITTERS	48

I. APPENDIX Exd



**APC-2000ALW/XX PRESSURE TRANSMITTER,
APR-2000ALW/XX, APR-2200ALW/XX,
DIFFERENTIAL PRESSURE TRANSMITTERS,
APR-2000YALW/XX LEVEL PROBE,**

Exd VERSION

1. Introduction

1.1. This “Appendix Exd.02” applies to transmitters of types **APC-2000ALW/XX, APR-2000ALW/XX, APR-2200ALW/XX** and **APR-2000YALW/XX** in Exd versions only, marked on the rating plate as shown in p.3 and denoted Exd in the Product Certificate.

1.2. The appendix contains supplementary information relating to the Exd (flame-proof) versions of mentioned transmitters.

During installation and use of Exd transmitters, reference should be made to **DTR.APC.APR.ALW.02(ENG)** in conjunction with “Appendix Exd”.

2. Use of APC... APR... transmitters in dangers zones.

2.1. The transmitters are produced in accordance with the requirements of the following standards:
EN 60079-0:2006, EN 60079-1: 2008, EN 60079-11:2007, EN 60079-26:2004, EN 61241-0:2006,
EN 61241-1:2004, EN-61241-11:2006

2.2. The transmitters may operate in areas where there is a risk of explosion, in accordance with the rating of the explosion protection design:



II 1/2G Ex ia/d IIC T5/T6

II 1/2D Ex iaD 20/tDA21 T85/T100

KDB 08 ATEX 224X

marking T6 and T85 applies to range $-40^{\circ}\text{C} < T_a \leq 45^{\circ}\text{C}$

marking T5 and T100 applies to range $-40^{\circ}\text{C} < T_a \leq 75^{\circ}\text{C}$

2.3. Transmitter category and hazard areas.

The category 1/2G, contained within the rating, means that the transmitter may be installed within a type 1 or 2 hazard zone. The APC..., APR... process connections may connect to a 0 zone type (see the diagram below for an example).

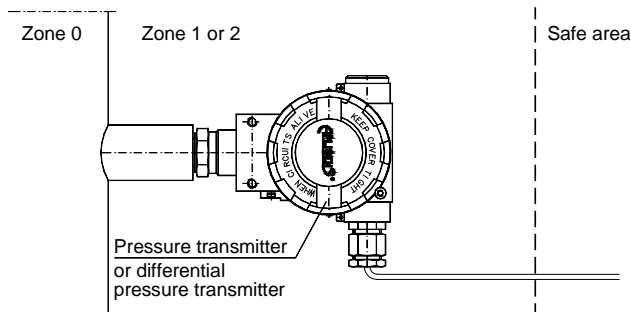

3. Identifying marks.

Flame-proof transmitters must have a rating plate containing the information specified in paragraph 4 of DTR.APC.APR.ALW.02(ENG) and also at least the following:

- CE mark and number of notified unit,  mark,
- designation of explosion protection design, certificate number,
- temperature use range,
- year of manufacture.

In place of XX letters in product rating plate will be write a pressure connection type symbols.

4. User information.

Together with the ordered transmitters, the user will receive:

- a. Product Certificate,
- b. Declaration of conformity,
- c. Copy of certificate – on request
- d. User's Manual numbered: DTR.APC.APR.ALW.02(ENG) with Appendix Exd0.2.

User can find them b), c), d) at www.aplisens.pl

5. Power supply and exploitation of transmitters.

5.1 The transmitter connecting should be made after introduction with present instruction content.

 Electrically transmitter should be connected according to scheme at p.6 Appendix Exd. Transmitter electrical installation should be realised with engineering standard requirements. Electrical connections of transmitters in danger zone should be made by people who have indispensable knowledge and experience in this branch.

5.2. Transmitters should be supplied from DC electrical source with voltage max.45V from transformer feeders or other devices which have at least a strengthened isolation among primary and secondary windings in which don't appear voltage higher than 250V. The duty of power supply installation with above mentioned requirements rests on user.

5.3. Transmitters can be use in ambient temperatures (Ta) between $-40^{\circ}\text{C} < \text{Ta} \leq 45^{\circ}\text{C}$ for T6 class or between $-40^{\circ}\text{C} < \text{Ta} \leq 75^{\circ}\text{C}$ for T5 class.

5.4. Transmitter sensor diaphragm not should be subject on damage during installation and exploitation. The diaphragm is made from 316ss or Hastelloy thin foil and cannot be subject on medium which can entail its damage.

5.5. With regard on kind of casing material (light alloy with large aluminium content), the user is obliged to assure, that possibility of hitting casing does not step out in place of transmitter installation.

5.6. In transmitter casing are two holes to assembly of packing glands from thread M20x1,5 or 1/2 NPT.

5.7. Normally transmitters are delivered without installed glands but with blank plugs (corks) in the second hole. They are at table 1 and table 2 at list of packing glands and plugs agreeable with production documentation and accepted by certificate station. Customer should install packing glands according to tables 1 and plugs according to tables 2 (if plugs aren't installed) or other accordance with flame-proof standards.

5.8. It is necessary apply a shield cable or without shield cable with round cross-section in protection from elastomer, not moisture absorbing, for example: YKSLY 2 * 1, YnTKSYekw 1 * 2 * 1, LIYCY 2 * In case of need of use cable about different building customer should co-ordinate this with transmitters manufacturer to choose intakes with cable diameter.

5.9. The general principles of connecting and the exploitation of transmitter in Exd realization should be compatible with principles and relating standards for Exd casing devices how in p.2.1, in this including also : EN600079-14, EN60079-17.

5.10. During service must be made a check of the tight fastening of covers and the packing glands and the fastening of the cable in the glands. The casing and supply line must be inspected for mechanical damage, and the transmitter rating plate for legibility. Periodic checks should also be made of the diaphragm, which should not carry signs of damage. During maintenance it is recommended that the threads of the covers be lubricated with non-acid vaseline.

Blocking cover method before unscrewing and plumbing possibility is showed at fig 20.



Because of the transmitter damage possibility, the ambient temperature should not be allowed to become higher than 80°C, even when there is no explosion risk.



It is not permitted to repair or otherwise interfere with the transmitter's electrical circuits in any way. Damage estimation and repair possibility may be assessed by the manufacturer or another authorized party only.



In danger zone don't unscrew transmitter covers and don't change the display position or its back lighting.

6. How to connect Exd transmitters APC..., APR...

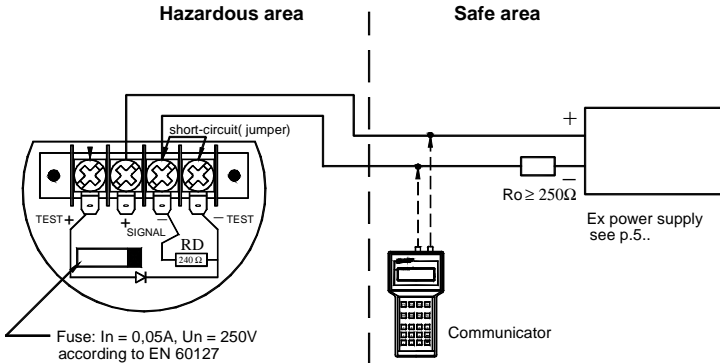

Fig. 2.

In case of transmitter calibration outside danger zone is possible communicator connecting to <SIGNAL+> and <TEST+> terminals. Transmitter is furnished in communication resistor ($R_D = 240\Omega$), closed with jumper at <SIGNAL-> and <TEST-> terminals installed by manufacturer. R_D resistor can be use then, when it is necessary to communicate with transmitter from its terminals and the load resistance (R_o) in current loop is lower than 250Ω . Than <SIGNAL-> and <TEST-> terminals have to be open.

Table 1. permitted packing glands

Type	Producer	Screw	Feature	Other marking	No of certificate	
501/423	HAWKE	M20x1,5	Exd IIC	dimension OS, O, A	Baseefa 06 ATEX 0056X	
501/421	HAWKE	M20x1,5	Exd IIC	dimension OS, O, A	Baseefa 06 ATEX 0056X	
ICG 623	HAWKE	M20x1,5	Exd IIC	dimension OS, O, A	Baseefa 06 ATEX 0058X	
501/453	HAWKE	M20x1,5	Exd IIC	dimension OS, O, A	Baseefa 06 ATEX 0056X	*
501/453/RAC	HAWKE	M20x1,5	Exd IIC	dimension OS, O, A	Baseefa 06 ATEX 0056X	*
501/453/Universal	HAWKE	M20x1,5	Exd IIC	dimension OS, O, A	Baseefa 06 ATEX 0057X	*
ICG 653	HAWKE	M20x1,5	Exd IIC	dimension OS, O, A	Baseefa 06 ATEX 0058X	*
8163/2-A2F	STAHL	M20x1,5	Exd IIC		SIRA06ATEX1188X	
A2F, A2FRC, SS2K	CMP-Products	M20x1,5	Exd IIC		SIRA06ATEX1097X	
E1FW, E1FX/Z, E2FW, E2FX/Z	CMP-Products	M20x1,5	Exd IIC		SIRA06ATEX1097X	*
T3CDS, T3CDSPB	CMP-Products	M20x1,5	Exd IIC		SIRA06ATEX1283X	*
PX2K, PXSS2K, PX2KX, PXB2KX	CMP-Products	M20x1,5	Exd IIC		SIRA06ATEX1097X	*

Table 2. permitted plugs

Type	Producer	Screw	Feature	Other marking	No certificate	
	AGRO AG	M20x1,5	Exd IIC			
475	HAWKE	M20x1,5	Exd IIC			
477	HAWKE	M20x1,5	Exd IIC			

*) for special cable only.

II. APPENDIX Exi



**APC-2000ALW PRESSURE TRANSMITTER,
APR-2000ALW, APR-2200ALW, APR-2000GALW
DIFFERENTIAL PRESSURE TRANSMITTERS,
APR-2000YALW LEVEL PROBE,**

Ex VERSION



1. Introduction

1.1. This “Appendix Exi” applies to transmitters of types **APC-2000ALW, APR-2000ALW, APR-2200ALW, APR-2000GALW and APR-2000YALW** in Ex versions only, marked on the rating plate as shown in 2.2 and denoted Ex in the Product Certificate.

1.2. The appendix contains supplementary information relating to the Ex versions of these transmitters. During installation and use of Ex transmitters, reference should be made to **DTR.APC.APR.ALW.02(ENG)** in conjunction with “Appendix Exi”.

2. Use of APC... APR... transmitters in danger zones.

- 2.1. The transmitters are produced in accordance with the requirements of the following standards
EN 60079-0:2009, EN 60079-26:2007, EN 60079-11:2007, EN 61241-11:2006, EN 50303:2000
- 2.2. The transmitters may operate in areas where there is a risk of explosion, in accordance with the rating of the explosion protection design:



II 1/2G Ex ia IIC T4/T5 Ga/Gb
II 1D Ex ia IIIC T105°C Da
I M1 Ex ia I Ma (version with enclosure ss316)
FTZÚ 08 ATEX 0020

2.3. Transmitter category and hazard areas

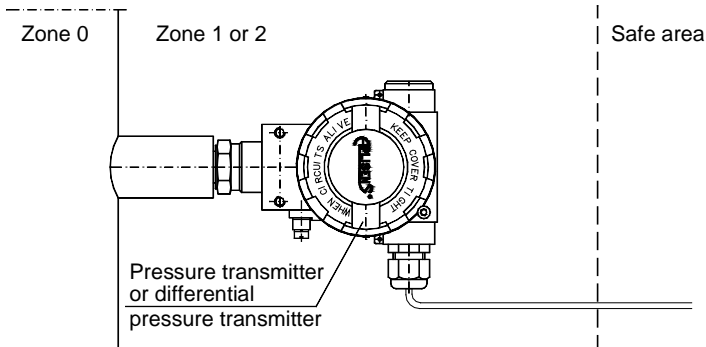
The category 1/2G, contained within the rating, means that the transmitter may be installed within a type 1 or 2 hazard zone. The APC..., APR... process connections may connect to a 0 zone type (see the diagram below for an example).



3. Identifying marks.

Intrinsically safe transmitters must have a rating plate containing the information specified in paragraph 4 of **DTR.APC.APR.ALW.02(ENG)** and also at least the following:

- CE mark and number of notified body;  mark
- designation of explosion protection design, certificate number
- values of parameters such as. Ui, Ii, Pi, Ci, Li
- year of manufacture

4. User information.

Together with the ordered transmitters, the user will receive:

- Product Certificate,
- Declaration of conformity,
- Copy of certificate – on request
- User's Manual numbered: DTR.APC.APR.ALW.02(ENG) with Appendix Exi.

User can find them at www.aplisens.pl

5. Permitted input parameters (based on data from the FTZÚ 08 ATEX 0020 certificate, and certification documentation).



The transmitters should be powered via the associated power feeding and measurement devices provided with the relevant intrinsic-safe certificates. The parameters of their outputs to the danger zone should not exceed the limit power supply parameters for the below specified transmitters.

5.1 - for power supply with a "linear" characteristic

$$U_i = 28V \quad I_i = 0,1A \quad P_i = 0,7W \quad \text{for } T_a \leq 70^\circ\text{C i T5}$$

Power supply with a "linear" characteristic may be e.g. a typical barrier with parameters $U_o = 28V \quad I_o = 0.093A \quad R_w = 300\Omega$.

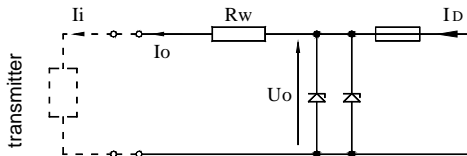

Fig.1. Power supply from a source with "linear" characteristic

5.2 - for power supply with a "trapezoidal" characteristic

$$U_i = 24V \quad I_i = 50mA \quad P_i = 0,7W \quad \text{for } T_a \leq 80^\circ\text{C and T5}$$

Example of power supply from a source with "trapezoidal" characteristic (see Fig. 2).

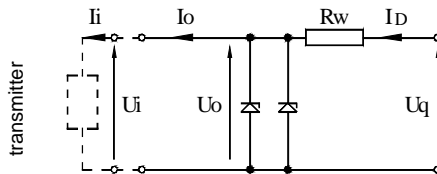

Fig. 2. Power supply from a source with "trapezoidal" characteristic

If $U_o < \frac{U_q}{2}$ then parameters U_q , I_o , P_o are interrelated as follows:

$$U_q = \frac{4P_o}{I_o} \quad , \quad R_w = \frac{U_q}{I_o} \quad , \quad P_o = \frac{U_o(U_q - U_o)}{R_w} \quad \text{for } U_o \leq 1/2U_q$$

5.3 - for power supply with "rectangular" characteristic

$$U_i = 24V \quad I_i = 25mA \quad P_i = 0,6W \quad \text{for } T_a \leq 80^\circ\text{C and T5}$$

$$U_i = 24V \quad I_i = 50mA \quad P_i = 1,2W \quad \text{for } T_a \leq 80^\circ\text{C and T4}$$

The supply of power from a source with a "rectangular" characteristic means that the voltage of the Ex power supply remains constant until current limitation activates.

The protection level of power supplies with a "rectangular" characteristic is normally "ib".

The transmitter powered from such a supply is also a Ex device with protection level "ib".

Example of practical provision of power supply.

- use a stabilized power supply with $U_o=24V$ with protection level „ib” and current limited to $I_o=25mA$.

5.4. Input inductance and capacity $C_i = 20nF, \quad L_i = 1,1mH$

5.5. Temperature of measured medium can not cause increase temperature housing of transmitter above the ambient temperature T_a specified for a given category

5.6. Supply voltage min. 13,5VDC **

5.7. Load resistance:

from 28V linear supply

$$R_o \text{ max } [\Omega] = \frac{28V - 13.5V^{**} - (300\Omega \cdot 0.02A)}{0,0225A}$$

for transmitter without display back lighting

from a source with "trapezoidal" or "rectangular" characteristic supply

$$R_o \text{ max } [\Omega] = \frac{U_{\text{sup.}} - 13.5V}{0,0225A}$$

*) barrier resistance

**) 16,5V for transmitter with display back lighting

6. How to connect Ex transmitters APC..., APR...

The transmitter and other devices in the measuring loop should be connected in accordance with the intrinsic-safety and explosion-safety regulations and the conditions for use in dangerous areas.



Failure to observe the intrinsic-safety regulations can cause explosion and the resulting hazard to people.

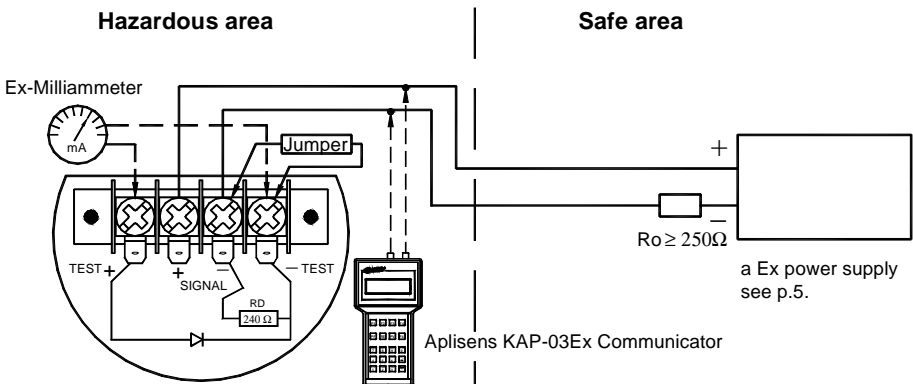

To measure the current in the transmitter without disconnecting the signalling circuit, connect a milliammeter to control sockets TEST+, TEST-.



In hazardous areas, connections to the control terminals must be made using only instruments which are permitted to be used in such areas.



The transmitter is equipped in additional communication resistor $RD = 240\Omega$

During normal operation terminals <Signal -> and <Test -> are shorted.

RD resistor is used when you wish to communicate with the transmitter locally (from its terminals) and $R_o < 250\Omega$. Terminals <Signal -> and <Test -> must be opened.

Transmitter electrical installation should be realised with engineering standard requirements.



It is not allowed to repair or otherwise interfere with the transmitter's electrical circuits in any way. Damage and possible repair may be assessed only by the manufacturer or another authorized party.

1. INTRODUCTION

1.1. This Manual is intended for users of **APC-2000ALW** smart pressure transmitters, **APR-2000ALW**, **APR-2200ALW**, **APR-2200GALW** smart differential pressure transmitters, and **APR-2000YALW** smart level probe and their intrinsic-safety versions, containing the data and guidelines necessary to understand the functioning of the transmitters and how to operate them. It includes essential recommendations concerning installation and use, as well as emergency procedures. The parameters and information specified for transmitters identified herein with the sign **APC...**, **APR...** also apply to transmitters: **APC-2000ALW**, **APR-2000ALW**, **APR-2200ALW**, **APR-2200GALW**, **APR-2000YALW** and their explosion-proof versions, as well as all the variations differing by the type of the process terminals. Information on the transmitter sizes and the method of installation apply to both, all versions of transmitters.

1.2. Technical data for the diaphragm seals and for the **APC...** and **APR...** transmitters are contained in the catalogue cards "DIAPHRAGM SEALS".

1.3. The transmitters comply with the requirements of EU directives as shown on the plate and with the relevant Declaration of Conformity.



1.4. Additional data on **APC-2000ALW**, **APR-2000ALW**, **APR-2200ALW**, **APR-2000GALW** and **APR-2000YALW** transmitters in Ex versions is contained in the appendix designed to **DTR.APC.APR.ALW.02(ENG)**. **Exi Appendix** and in Exd versions in the appendix designed to **DTR.APC.APR.ALW.02(ENG)**. **Exd Appendix**.

During installation and use of the transmitters in Ex or Exd version, reference should be made to **DTR.APC.APR.ALW.02(ENG)** in conjunction with **Exi** or **Exd Appendix**.

1.5. The pressure transmitters: **APC-2000ALW**, **APR-2000ALW** in realization for sea uses are complied with Det Norske Veritas (DNV) Rules for Classification of Ships, High Speed & Light Craft and Det Norske Veritas' Offshore Standards. Certificate **No. A -11308** for application in following Location Classes: Temperature **C**, Humidity: **B**, Vibrations: **B**, EMC: **B**, Enclosure: **C**. The pressure transmitters: **PCE-28**, **PCE-28P**, **PRE-28** in realization for sea uses are complied with Det Norske Veritas (DNV) Rules for Classification of Ships, High Speed & Light Craft and Det Norske Veritas' Offshore Standards. Certificate **No. A -11308** for application in following Location Classes: Temperature **C**, Humidity: **B**, Vibrations: **B**, EMC: **B**, Enclosure: **C**.

1.6. The **APC...**, **APR...** transmitters are also made in a version which complies with the PED Pressure Directive, meet the requirements for category IV, and then carry additional markings as in 4.3.

2. USER MATERIALS

Transmitters are delivered in single and/or multiple packs.

Together with the transmitter are delivered:

- a) Product certificate, which is also as the warranty card
- b) Declaration of conformity - on request
- c) Copy of ATEX certificate – on request,
- d) User's Manual numbered: **DTR.APC.APR.ALW.02(ENG)**.

Items b), c), d) are available at: www.aplisens.pl

3. APPLICATIONS AND MAIN FEATURES

3.1. The **APC...** smart pressure transmitters are designed to measure gauge pressure, vacuum pressure and absolute pressure of gases, vapours and liquids (including corrosive substances).

Differential pressure transmitters type **APR...** are used to measure liquid levels in closed tanks, with static pressure up to 25MPa, or 32MPa for special versions and to measure differential pressure across constrictions such as filters and orifices.



3.2. The transmitters may be fitted with a range of types of process connectors, which enables them to be used in a variety of conditions such as thick or highly reactive media, high and low temperatures, etc.

3.3. **APC...**, **APR...** transmitters generate a 4...20mA output signal and a digital communication signal in a two-wire system (current loop). The use of smart electronics enables regulation of the zero point, the measurement range, damping, radical conversion characteristic and other functions using an Aplisens **KAP** communicator or from a PC using a Hart/RS232 converter and Aplisens "Raport" configuration software.

4. IDENTIFYING MARKS. ORDERING PROCEDURE

4.1. Every transmitter carries a rating plate containing at least the following information: CE mark, manufacturer name, transmitter type, serial number, pressure range, static pressure limit, output signal, power supply voltage.

Version types and the method of specifying the desired product are described in the current "Information Cards" and the Catalogue.

4.2. APC...APR...transmitters in Ex version or Exd version have additional markings as described in DTR.APC.APR.ALW.02(ENG) Appendix Exi or Exd.



4.3. The rating plates of APC... , APR... transmitters in versions compliant with the PED pressure directive contain the notified unit number 0062 next to the CE mark, as well as the designations of certificates number:

CE-PED- H1D-APL003-04-POL rev.A for **APC...** transmitters, module **H1D + H1** (category IV)

CE-PED-H1D-APL 002-05-POL rev.B for **APR...** transmitters, module **H1D + H1** (category IV)

CE-PED-H1-APL 001-11-P0L

CE-PED-B-APL 001-09-POL,

CE-PED-D-APL 001-09-POL - for **APC-2000ALW, APR-2000ALW,** module **B + D**(category IV)



4.4. APC...APR... transmitters in realization for sea uses have additional information about signs Location Classe and DNV Certificate **No. A-11308.**

5. TECHNICAL DATA.

5.1. APC..., APR...- Common parameters

5.1.1. APC..., APR... Electrical parameters

Power supply

12* ÷ 55V DC

Power supply for intrinsic-safe versions

in accordance with Appendix Exi.



Output signal

4÷20mA + Hart rev.5.1

Communication

realised via a 4÷20mA signal using KAP-03 communicator or RS/Hart modem and PC computer with "Raport" software

Resistance for communication

250÷1100Ω, min 240Ω

Load resistance

$$R_{Lmax}[\Omega] = \frac{U_{sup}[V]-12V^*}{0,0225A}$$

$$U_{supply \text{ min.}} = 12^* + 0,0225 \times R_L [V]$$

*) 15V for transmitters with display backlight.

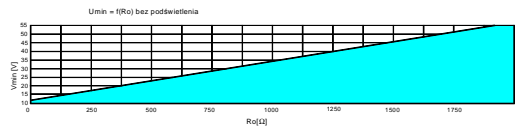
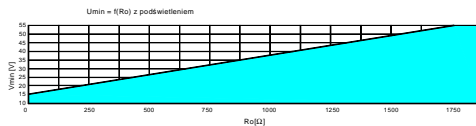

Safe working area (grid) upper colour area.

Output updating time

500ms

Additional electronic damping

0...30s

Voltage for insulation testing

500 VAC or 750 VDC, see p.9.3.

Excess voltage protection

see p.9.3.

Response time on pressure stroke.

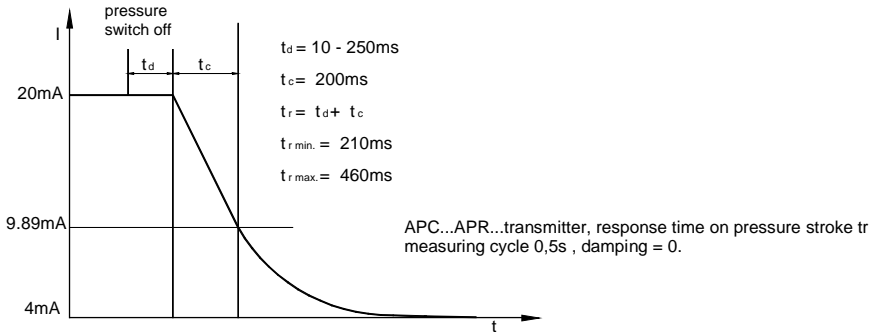

5.1.2. APC..., APR... Permitted environmental conditions

Operating temperature range $-40^\circ\text{C} \div 85^\circ\text{C}$ (for PED version in accordance with p. 5.2.3.)



Operating temperature range for intrinsic-safe versions in accordance with Appendix Exi

Operating temperature range for flame-proof versions in accordance with Appendix Exd

Medium temperature range

$-40^\circ\text{C} \div 120^\circ\text{C}$ – for direct measurement,
for PED version in accordance with p. 5.2.3.
over 120°C measurement with a transmission
tube or diaphragm seal using
in accordance with Appendix Exi.

for intrinsic-safe versions
Thermal compensation range

$-25^\circ \div 80^\circ\text{C}$,
($-40^\circ \div 80^\circ\text{C}$ for special version APC...)

Relative humidity

max. 98%

5.1.2.1. Electromagnetic Compatibility (EMC), immunity

Rating according to EN 61326-1,2 for industrial applications

Electrostatic Discharge Immunity (ESD):

EN 61000-4-2; S3 level: contact $\pm 6\text{kV}$, air $\pm 8\text{kV}$; criterion A

Conducted Radio Frequency:

EN 61000-4-6; 0,15... 80MHz, 10V; criterion A

Radiated electromagnetic Field:

EN 61000-4-3; 80... 2 000MHz – 10V/m, 2 000 ... 2 700MHz – 1V/m; criterion A

Electrical Fast Transient (Burst Immunity)

EN 61000-4-4; $\pm 2\text{kV}$ power supply port/earth, $\pm 1\text{kV}$ signal port/earth; criterion A

Electrical Slow Transient (Surge Immunity):

EN 61000-4-5; $\pm 0.5\text{kV}$ ($\pm 1\text{kV}$) 0,5kV differential mode, 1kV common mode; criterion B

5.1.2.2. Electromagnetic Compatibility, emission:

According to CISPR16-1, CISPR 16-2, class B, distance to the antenna 3m, quasi-peak measuring:

Radiated emission: 0,15 ... 30MHz, 80-52dB $\mu\text{V}/\text{m}$;

30 ... 2000MHz, <54dB $\mu\text{V}/\text{m}$

Conducted emission: 0,01 ... 0,150MHz, 96-50dB $\mu\text{V}/\text{m}$;

0,150 ... 0,350MHz, 60-50dB $\mu\text{V}/\text{m}$;

0,35 ... 30MHz, <50dB $\mu\text{V}/\text{m}$

5.1.2.3. Climatic immunity: dry heat, cold, humidity, salt mist:

Dry heat:

EN 60068-2-2, test B; T = 70°C, RH = max 55%

Cold :

EN 60068-2-1, test A; T = -25°C,

Damp heat cycle:

EN 60068-2-30, test D ; (T = 55°C, RH = min95%, 24h)x2

Salt mist:

EN 60068-2-52; (spraying: 2h duration, T = 25°C, storage in damp chamber: 7 days, T = 40°C, RH = 93%)x4, 28days total

5.1.2.4. Mechanical immunity

Shocks:

EN 60068-2-27, 50g/11ms

Vibrations:

EN 60068-2-6, test Fc; up to 1,6mm for 2 ... 25Hz, up to 4g for 25 ... 100Hz

5.1.3.1. Insulation Resistance

>100 MΩ @110V transmitters with gas arresters

>100 MΩ @750V DC transmitters without gas arresters (Exi)

5.1.3.2. High Voltage Test

500V AC, or 750V DC, 1min, transmitters without gas arresters (Ex applications)

75V AC, or 110V DC, 1min, transmitters with gas arresters

5.1.4. Enclosure ingress protection

EN 60529, IP 66,67

5.1.5. APC..., APR... Construction materials

Diaphragm seal for APC...

Stainless steel 316L (00H17N14M2)(PED version) or Hastelloy C276

Diaphragm seal for APR...

Stainless steel 316L (00H17N14M2)(PED version) or Hastelloy C276

Sensing module

Stainless steel 316L (00H17N14M2)

Liquid filling the interior the sensing module

Silicone oil, chemically inactive liquid for measurement of oxygen uses.

Connectors for APC...

Stainless steel 316L (00H17N14M2) or
Hastelloy C276 only for P, GP, CM30x2

C-type vented covers and connectors for APR..

Stainless steel 316L (00H17N14M2)

Electronics casing

High pressure cast of aluminium alloy, lacquered with
chemical-resistant oxide enamel, colour yellow (RAL 1003).

5.2. APC...- Measurement ranges and metrological parameters.

5.2.1. APC..., Measurement ranges

N°	Nominal measuring range (FSO)	Minimum set range	Rangeability	Overpressure limit (without hysteresis)
1.	0...1000bar (0...100MPa)	10bar (1MPa)	100:1	1200bar (120MPa)
2.	0...300bar (0...30MPa)	3bar (300kPa)	100:1	450bar (45MPa)
3.	0...160bar (0...16MPa)	1,6bar (160kPa)	100:1	450bar (45MPa)
4.	0...70bar (0...7MPa)	0,7bar (70kPa)	100:1	140bar (14MPa)
5.	0...25bar (0...2,5MPa)	0,25bar (25kPa)	100:1	50bar (5MPa)
6.	0...7bar (0...0,7MPa)	0,07bar (7kPa)	100:1	14bar (1,4MPa)
7.	-1...6bar (-100...600kPa)	300mbar (30kPa)	23:1	14bar (1,4MPa)
8.	0...2bar (0...200kPa)	100mbar (10kPa)	20:1	4bar (400kPa)
9.	0...1bar (0...100kPa)	50mbar (5kPa)	20:1	2bar (200kPa)
10.	-0,5...0,5bar (-50...50kPa)	50mbar (5kPa)	20:1	2bar (200kPa)
11.	0...0,25bar (0...25kPa)	25mbar (2,5kPa)	10:1	1bar (100kPa)
12.	-100...100mbar (-10...10kPa)	20mbar (2kPa)	10:1	1bar (100kPa)
13.	-15...70mbar* (-15...7kPa)	5mbar (0,5kPa)	17:1	0,5bar (50kPa)
14.	-7...7 mbar* (-700...700Pa)	1mbar (0,1kPa)	14:1	0,5bar (50kPa)
15.	0...1,3bar abs (0...110kPa abs)	50mbar abs (5kPa abs)	26:1	2bar (200kPa)
16.	0...7bar abs (0...7MPa abs)	0,07bar abs (7kPa abs)	100:1	14bar (1,4MPa)
17.	0...25bar abs (0...2,5MPa abs)	0,25bar abs (25kPa abs)	100:1	50bar (5MPa)
18.	0...70bar abs (0...7MPa abs)	0,7bar abs (70kPa abs)	100:1	140bar (14MPa)

* - only for transmitters without diaphragm seal,

5.2.2. APC..., Metrological parameters

Accuracy	max ± 0,075% for the basic range (0,16% for range 14)
Long term stability	≤ accuracy for 3 years (for the nominal measuring range)
Error due to supply voltage changes	max ± 0,002%(FSO)/1V
Thermal error	max ± 0,08%(FSO)/10°C
	max ± 0,1% FSO/10°C for n°12, 13, 14 ranges.
Thermal error for the whole thermal compensation range	max ± 0,25%(FSO) (max ± 0,4% FSO/10°C for n°12, 13, 14 ranges.)

5.2.3. APC..., APR... Metrological Parameters according to PED version.

APC... transmitters, in the PED Pressure Directive versions, are produced with a measurement range in the interval from -100 kPa to 40MPa gage, or from 0 to 40MPa absolute, with the overpressure up to 44 MPa. Temperature limit -40 ÷ 100°C (-40 ÷ 150°C with S-Mazut connector).

APR... transmitters, in the PED Pressure Directive versions, are produced with a measurement range in the interval from -100 kPa to 2,5MPa gage, with the static pressure 25MPa and the overpressure up to 27,5 MPa. Temperature limit -25 ÷ 100°C.

APC... pressure transmitters with the S-Mazut seal pressure connection, assembled with the PED version can be produced within the range-100 kPa to 10 MPa gage, or within the 0 - 10 MPa absolute, and the overpressure up to 11 MPa. Other parameters are as given in Tables 1, except that the ambient temperature error is 0.7 kPa/10°C. The value of the pressure measurement range and related overpressure are given on rating plate and at Product Certificate.

5.2.3. APC..., Pressure Connectors

M-type connector with M20x1.5 thread – see figure 5a, available for PED version
P-type connector with M20x1.5 thread – see figure 6a, available for PED version
CM30x2-type connector with flush diaphragm – see figure 7a,
G1/2 -type connector with G1/2" thread – see figure 8a, available for PED version
GP -type connector with G1/2" thread, available for PED version
CG1-type connector with G1" thread and flush diaphragm – see figure 8e, available for PED version
RM-type connector with M20x1.5 thread and radiator
RP-type connector with M20x1.5 thread and radiator

G1/4-type connector with G1/4 thread, available for PED version
 1/2"NPT -type connector with 1/2"NPT tread, available for PED version
 R1/2-type connector with R1/2 tread, available for PED version
 CG1/2-type connector with G1/2 tread and flush diaphragm, available for PED version
 other connection types by arrangement.

5.3. APR-2000ALW, APR-2200ALW Measurement ranges and metrological parameters.

5.3.1. APR-2000ALW, Measurement ranges

N°	Nominal measuring range (FSO)	Minimum set range	Rangeability	Overpressure limit	Static pressure limit
1	0...16bar (0...1,6MPa)	1,6bar (160kPa)	10:1	250, 320bar (40bar for P-type connector) (250bar for version compliant with the PED pressure directive)	
2	0...2,5bar (0...250kPa)	0,25bar (25kPa)	10:1		
3	0...1bar (0...100kPa)	70mbar (7kPa)	14:1		
4	0...0,25bar (0...25kPa)	10mbar (1kPa)	25:1		
5	-100...100mbar (-10...10kPa)	4mbar (0,4kPa)	50:1		
6	-5...70mbar (-0,5...7kPa)	4mbar (0,4kPa)	18:1		
7	-0,5...0,5bar (-50...50kPa)	0,1bar (10kPa)	10:1		
8	-25...25mbar (-2,5...2,5kPa)	2,5mbar (0,25kPa)	20:1		

5.3.2. APR-2200ALW, Measurement ranges

Nominal range (FSO)	Minimum set range	Vertical spacing of diaphragm seals.	Maximum configurable range dependent on the actual vertical spacing of diaphragm seals. (m)	Static pressure limit
-160...160 mbar	0,1 mH ₂ O	≤ 1,7m	[1,6+(vertical spacing of sealsx94)]mH ₂ O	40bar
-0,5...0,5 bar	0,5 mH ₂ O	≤ 6m	[5+(vertical spacing of sealsx1,04)]mH ₂ O	40bar
-1,6...2 bar	1,5 mH ₂ O	≤ 15m	[20+(vertical spacing of sealsx1,04)]mH ₂ O	40bar
-1,6...16 bar	1bar	≤ 15m	16bar	40bar

The maximum vertical diaphragm seal spacing shown in the table applies to level measurement, ensuring that it is possible to set the zero point of the transmitter when the tank is empty.

For measurements of density or phase boundaries (in the sugar and chemical industries and in refineries) the vertical spacing of the diaphragm seals can be larger.

i

5.3.3. APR-2000ALW, APR-2200ALW Metrological parameters

Accuracy	± 0,075% (FSO) for the APR-2000ALW nominal range
Long term stability	≤ accuracy / 3 years
Error due to supply voltage changes	± 0,002%(FSO)/1V
Thermal error	± 0,08%(FSO)/10°C
Thermal error for the whole thermal compensation range	± 0,3%(FSO)
Zero shift error for static pressure*	± 0,08 % (FSO)/10bar ± 0,01 % (FSO)/10bar (for range n ⁴) ± 0,03 % (FSO)/10bar (for range n ⁵ , 6)
Cut-off on radical characteristic curve	up to10% of flow.

* zeroing in static pressure conditions with zero differential pressure eliminate this error.

5.3.4. APR-2000ALW, Pressure Connectors

APR-2000/ALW– C-type connector to mount together with a valve manifold see fig.9, available for PED version
APR-2000/ALW with single direct diaphragm seal – as in the example (fig.10) or with other diaphragm seals in accordance with "DIAPHRAGM SEALS" catalogue cards.

5.3.5. APR-2200ALW. Pressure Connectors - diaphragm seals – see "DIAPHRAGM SEALS" catalogue cards.

5.4. APR–2000GALW. Measurement ranges and metrological parameters.

5.4.1 APR–2000GALW. Measurement ranges

N°	Nominal range (FSO)	Minimum set range	Overpressure limit	Static pressure limit
1	0...25mbar (0...2500Pa)	1mbar (100Pa)	1bar	350mbar
2	-2,5...2,5mbar (-250...250Pa)	0,2mbar (20Pa)	350mbar	350mbar
3	-7...7mbar (-700...700Pa)	1mbar (100Pa)	350mbar	350mbar
4	-25...25mbar (-2500...2500Pa)	5mbar (500Pa)	1bar	1bar
5	-100...100mbar (-10...10Pa)	20mbar (2kPa)	1bar	1bar

5.4.2. APR–2000GALW. Metrological parameters.

Nominal range	0...25mbar	-2,5...2,5mbar	-7...7mbar	-25...25mbar	-100...100mbar
Accuracy	≤ ± 0,075 %	≤ ± 0,16 %	≤ ± 0,1 %	≤ ± 0,1 %	≤ ± 0,075 %
Thermal error	± 0,1 % (FSO)/ 10°C, max ± 0,4 % (FSO) for the whole thermal compensation range				
Thermal compensation range	-10 ... 70°C				
Additional electronic damping	0...60 s				

5.4.3. APR–2000GALW. Construction materials

M20x1,5/Ø6x1 adapter	brass
Valve manifold	ss316L
Valve manifold adapter	ss316L
¼ NPT connector	brass, ss316L or galvanized St3S carbon steel

(Other materials as given in 5.1.3 for APR...).

5.4.4. APR–2000GALW. Pressure Connectors

- The terminals fit adapted to ø 6x1 plastic tubes,
- Valve manifold adapter or ¼ NPT connector- (see p. 8.3. and fig.17).

5.5. APR–2000YALW. Measurement ranges and metrological parameters.

5.5.1. APR–2000YALW. Measurement ranges.

N°	1	2
Nominal range	0... – 6000 mmH ₂ O	0... – 1600 mmH ₂ O
Minimum set range	600 mmH ₂ O	160 mmH ₂ O
Static pressure limit	40 bar	

5.5.2. APR–2000YALW. Metrological parameters.

Nominal range N°	1	2
Accuracy for basic range	± 0,16 %	± 0,2 %
Accuracy for minimum range	± 0,5 %	± 0,6 %
temperature error	0,4 % for temperatures –25...+80°C	
Zero shift error from static pressure *	0,08 % / 10bar	0,1 % / 10bar

* zeroing in static pressure conditions with zero differential pressure eliminate this error.

Medium density range – up to 1,1 g/cm³ – (standard version)
 – over 1,1 g/cm³ – (special version by arrangement with APLISENS)

6. CONSTRUCTION

6.1. Measurement Principles, Electronic System.

APC... electronic pressure transmitters and **APR...** electronic differential pressure transmitters work by converting changes in the resistance of a piezoresistance bridge, which are proportional to the measured pressure, into a standard current signal. The active sensing element is a silicon diaphragm with piezoresistors, separated from the medium by a sealing diaphragm and manometric fluid. The electronic system digitally processes the measurement signal and generates output signals: an analogue 4÷20 mA signal with a digital communication signal.

A block diagram of the transmitter is presented in Figure 1. At the circuit input two analogue signals are provided: the measured pressure reflecting and the sensing module temperature. These signals are digitalized and provided to a microprocessor input which controls the transmitter's operation. Using input data during the production process adjusts for thermal errors and carries out linearization. After digital processing, the signal is converted into an analogue 4÷20mA current signal again, with a superimposed digital communication signal.

For communication with the transmitter via the signal line a special Aplisens KAP communicator, or a computer meeting the requirements given in 10.2.4, are used.

The transmitter's output is fitted with a radio-noise filter and other elements protecting against ESD.

6.2. Construction.

The basic units of transmitter are: measuring sensor, in which pressure signal is converted into electric signal, and electronic units, transforming signal from measuring sensor into unified output signal.

APC..., **APR...** transmitters are equipped in LCD display with **LED back lighting**, enabling reading two the process variables simultaneously as well as the unit process variable reading. The electronic board is closed in poly-carbonate casing. The casing construction enables turning of display by ± 180 with 90° pitch.

On the electronic casing the set of buttons is placed, used to local adjustment.

The transmitters construction enables connecting of the separately compensated measuring sensor to separately compensated electronic board enabling fast servicing at the plant.

The electronic circuit of sensor has a galvanic separation from measuring line. Thanks of that construction the measurement susceptibility at interferences is reduced as well as the enlarged safety of work in the Ex and flameproof applications.

The sensor memory contains 8 pressure shapes data bank which can (depending on factory settings) contain parameters describing behavior the same sensor in different pressures and/or temperatures ranges.

In dependence from needs we can choose a needed bank of coefficients memory for transmitter work. **APC...**, **APR...** transmitters **monitor** work of their equipment as well as the calculation correctness and in case of rises of incorrigibility inform about mistakes displaying the announcement on LCD screen as well as putting out the alarm current in current loop.

6.2.1. The pressure connectors may be fitted to the **APC...** sensing module as in figures 5a, 6a, 7a, 8 and other. The **APR...** transmitters have the sensing modules with two P-type connectors, or C-type connecting covers for installation on a valve manifold (figure 9). The sensing modules, for both types, are equipped with a diaphragm separating the internal part of the head from the measuring medium.

6.2.2. For measuring the pressure of dense, chemically reactive or hot media, the transmitter may be additionally fitted with various types of diaphragm seal depending on the type of medium and the conditions in which measurement is carried out (see catalogue cards "Diaphragm Seals).

The diaphragm seal transmits the pressure obtained from the medium. The pressure is transmitted via a manometric fluid which fills the space between the diaphragm of the seal and the diaphragm of the sensing module. In the case of remote diaphragm seals, pressure is transmitted via a capillary linking the transmitter's sensing module to the diaphragm seal. The seals construction depends on the medium properties and operating conditions for which they are intended.



Technical data relating to the diaphragm seals' dimensions and operating conditions can be found in catalogue cards "DIAPHRAGM SEALS".

6.2.3. The **APR...** transmitters may be fitted with a single direct diaphragm seal, mounted on the "+" pressure input of the sensing module, while the "-" input is a $\frac{1}{4}$ NPT F connector (fig.10).

The **APR-2200ALW** transmitter is fitted with two diaphragm seals and can be produced in two versions:

- with one direct diaphragm seal and one remote diaphragm seal (fig.15);
- with two remote diaphragm seals (fig.14).

6.2.4. In the case of the **APR-2000GALW** transmitters, the sensing module is located inside the transmitter casing. It is designed for the measurement of low pressures of non-aggressive gases, with a permitted overpressure of 1bar (or 350mbar). The basic (economy) version of this transmitter has ø6x1 elastic tubes terminals fitting, while the industrial version has adapters as shown in fig. 17.

6.2.5. **APR-2000YALW** smart level probe is equipped in diaphragm seal and flange to fixing on tank.

7. PLACE OF INSTALLATION

7.1. General recommendations

7.1.1. The smart pressure transmitter and differential pressure transmitter can be installed both indoors and outdoors. It is recommended that transmitters intended for outdoor use be placed in a box or under cover.

7.1.2. The place of installation should be chosen in such a way as to allow access to the device and to protect it from mechanical damage. In planning the installation of the transmitter and configuration of the impulse lines, attention should be paid to the following requirements:

- The impulse lines should be as short as possible, with a sufficiently large cross-section, and free of sharp bends, in order to prevent blockages;
- Where the medium is a gas, the transmitters should be installed above the measuring point, so that condensation flows down towards the site of the pressure measurement; where the medium is a liquid or where a protective liquid is used, the transmitters should be installed below the place where the pressure measurement is taken;
- The impulse lines should be inclined at a gradient of at least 10cm/m;
- The levels of filling liquid in the impulse lines should be equal or kept constant difference,
- The configuration of the impulse lines and the valve connection system should be chosen with regard to the measurement conditions and to requirements such as the need to reset the transmitters in position and the need for access to the impulse lines during water or gas removal and flushing.



7.1.3. **Where there is a risk of heavy objects hitting the instrument (resulting, in extreme cases, in a part of the system with transmitters being torn off and medium leakage), appropriate means of protection should be applied for safety reasons and to avoid the possibility of sparking or other, more appropriate location should be selected for the transmitter.**



7.1.4. Attention should also be paid to possible installation faults which may lead to measurement errors, such as connections which are not tight, sediment blockage in lines which are too narrow, gas bubbles in a liquid line or liquid column in a gas line etc.

7.2. Low Ambient Temperature.



When the solidification point of the liquid whose pressure is being measured is higher than the ambient temperature, steps should be taken to protect the measurement apparatus from freezing effects.

This is particularly important in the case open-air installations.

Protection is obtained by filling the impulse lines with a mixture of ethylene glycol and water, or another liquid whose solidification point does not exceed the ambient temperature. Thermal insulation can protect the transmitter casing and lines only from brief exposure to low temperatures. Where the temperature is very low, the transmitter and impulse lines should be heated.

7.3. High Medium Temperature.

The **APC...**, **APR...** transmitters may be used to measure media with temperatures of up to 120°C. (PED version see p 5.2.3). To protect the sensing module from temperatures higher than 120°C, long impulse lines are used to disperse the heat and to lower the temperature of the sensing module.

Where it is not possible to use impulse lines of the required length, **APC...**, **APR...** transmitters with remote diaphragm seals should be used (see "DIAPHRAGM SEALS" catalogue cards).



Data as per Appendix Exi or Appendix Exd.02 apply for the Ex or Exd version.

7.4. Mechanical Vibration, Corrosive Media.

7.4.1. Transmitters should correctly work with vibrations with amplitudes to 1,6 mm and accelerations to 4g. If strong vibrations are carried via the pressure line and disturb of measuring, use should be made of elastic pulse lines or transmitters with a remote diaphragm seal.

7.4.2. Transmitters should not be installed in places where the diaphragm, made of 316L steel 00H17N14M2), would be subject to corrosion by the medium being measured. If possible, transmitters with diaphragms made of Hastelloy C276 should be used, or other means of protection applied (e.g. in the form of a separating liquid) or transmitters with diaphragm seals adapted for measuring aggressive mediums according to "DIAPHRAGM SEALS" catalogue cards should be used).



8. INSTALLATION AND MECHANICAL CONNECTIONS

The **APC...**, **APR...** transmitters can operate in any position.

When installed on an object with a high-temperature medium, it is advantageous to mount the transmitter in a horizontal position or downwards, in such a way that the transmitter is kept away from the rising hot air.



For the small measurement ranges, the reading can be affected by the transmitter position, and by the impulse lines configuration, or the way in which they are filled with liquid. This error can be corrected using the zero-setting function.

8.1. APC... Installation and connections

8.1.1. The **APC...** transmitters can be mounted directly on the rigid impulse lines.

For used connectors as in figures 5a, 6a and 7a, it is recommended that connection sockets be used as shown in figure 5b, 6b, 7b or 7c. It is recommended that sockets labeled "Socket CG1" and „Socket CG1/2" Fig. 8 are used for CG1 and CG1/2 connections, respectively.

Besides, there are adapters for standard DIN50, (DIN40, DIN25, Clamp2", Clamp1,5", Clamp1") type DIN connections provided for readouts carried out in aseptic conditions using transmitters with CM30x2 connection.

There are gaskets provided for every transmitter with P, CM30x2, CG1, CG1/2 and GP type connections. The gasket material is selected based on the pressure value, temperature and the type of the medium.

8.1.2. If the pressure is applied via a flexible plastic tube, the transmitter should be mounted on a support with Red Ø6-M reduction.

The types of the impulse tubes (Fig.21) are to be selected depending on the pressure measured value and the medium temperature.

8.1.3. Tighten the transmitter in the socket with a torque suitable for the type of the gasket used and the pressure measured.

8.1.4. The **APC...** transmitter can be installed using a universal "AL" holder allowing to mount the transmitter in any position on the support or a horizontal or vertical pipe Ø35... Ø65 (Fig. 16).

8.2. APR... Installation and connections

8.2.1. The **APR ...** transmitters can be mounted directly on rigid impulse lines.

To connect the transmitter basic versions, with two M20 x 1.5 connectors (P-type connector), can use (for example) straight connecting elements with C type nuts. If elastic impulse lines are used, the transmitter should be additionally fastened to a pipe, panel or supporting construction.

8.2.2. The **APR-2000ALW** and **APR-2200ALW** can be installed using the ø25 Fastener (fig.11) on a ø25 pipe or on a flat surface using an angle bracket.

8.2.3. The **APR-2000ALW** with connecting cover (C-type connector) (fig.9) are designed for installation on 3-valve or 5-valve manifolds to a 2" pipe or to a flat surface using "C-2" holder (fig.12), (fig.13).

8.3. APR-2000GALW. Installation and connections

8.3.1. The "economy" version of the **APR-2000G** transmitter can be mounted on a wall, panel or other stable construction, using a clamp with Ø9 holes (Fig.17). The transmitter is fitted with connectors which fit to a Ø6x1 elastic impulse tube. When the measuring impulse is transmitted via a metal terminal with M20 x 1.5 connector, an adapter is used between the M20 x 1.5 thread and the Ø6x1 terminal.

Transmitters should be installed in a vertical position. The way of impulse line leading should enable the vapour flowing towards the pipeline. Where there is a significant difference between the height at which the transmitter is mounted and the height of the impulse source, particularly if the measurement range is small, the reading may fluctuate depending on the temperature difference between the impulse lines. This effect can be reduced by ensuring that the impulse lines run side by side.

8.3.2. The **APR-2000GALW** transmitter can also be fitted with an adapter (Fig.17) creating a C-type connector, designed for installation on a 3-valve or 5-valve manifold. Aplsens can also supply ready transmitters mounted on valves.

8.4. APR-2000YALW. Installation and connections

The **APRE-2000YALW** level probes installed in places where liquid levels are measured in closed tanks, with access to medium from top of tank as fig.15 and 10.2.6. Level probes should be installed in a vertical position.

Pressure may be transmitted to the installed device only after checking that it has a measurement range which properly corresponds to the value of the measured pressure, that gaskets have been properly selected and fitted, and the connectors have been properly screwed tight.



Attempts to undo the screws or fixing connector pipes on a transmitter under pressure may cause the medium to leak and create hazards for the personnel.

When disassembling the transmitter, it is necessary to disconnect it from the process pressure or bring the pressure to atmospheric level, and to take particular care and precautions in case of media which are highly reactive, caustic, explosive or otherwise hazardous to personnel.

If necessary, rinse out this part of the system.

Transmitters with flange diaphragm seals are to be installed on the corresponding counter flanges on the facility.



It is recommended that the user matches the screw joints material to the pressure, temperature, flange material and seal to ensure tightness of the flange joint in the expected operating conditions..

Screws complying with ISO 261 are to be used for flanges used in the APC..., APR... transmitters.

Additional data concerning the diaphragm seals are specified in the "DIAPHRAGM SEALS" catalogue cards.

9. ELECTRICAL CONNECTION

9.1. General recommendations

9.1.1. It is recommended that twisted pair cabling be used for the signal lines. If the transmitter and signal line are subject to a large amount of electromagnetic interference, then shield pair cable should be used. The signal wires should not run alongside network power supply cables or near to large electrically-powered devices.

The devices used together with the transmitters should be resistant to electromagnetic interference from the transmission line in accordance with compatibility requirements. It is also beneficial to use anti-interference filters on the primary side of the transformers, the power supplies used for the transmitters and apparatus used in conjunction with them.

9.1.2. Wet or rising damp inside transmitter can cause its damage.



When the isolation of the wires in the packing gland is ineffective (for example, when single wires are used) the opening of the gland should be carefully sealed with an elastic sealing compound to obtain IP66 protection. It is useful to form the segment of the signal wire leading to the packing gland into a protective loop to prevent condensation from running down in the direction of the gland.

9.2. Electrical connections for APC..., APR...



The **APC...**, **APR...** transmitters are to be connected as shown in fig. 2a – 2d.

In **APC...**, **APR...** transmitters, a 240Ω resistor is permanently fitted in series in the transmitter's current circuit and blocked up with jumper between <SIGNAL → and <TEST → as shown in fig.2a and 2b.

When the resistance in the current loop is lower than 240Ω it is necessary to jumper disassemble to Hart communication.

9.3. Protection from excess voltage

9.3.1. The transmitters may be in danger from excess voltage caused by connection faults or atmospheric electrical discharge.

Protection from excess voltage between the wires of the transmission line is provided by TVS diodes installed in all types of transmitter (see the table, column 2).

9.3.2. In order to protect against excess voltage between the transmission line and the casing or earth (not prevented by the diodes connected between the transmission wires), additional protection is provided in the form of plasma surge arresters (see the table, column 3).

Also external protective devices may be used, e.g. the UZ-2 Aplisens system, or others. When the transmission lines are long, it is advantageous to use one protective device near the transmitter (or inside it), and another near entry points to other devices used in conjunction with it.

Internal protection of transmitters:

1	2	3
Type of transmitter	Protection between wires (TVS diodes) – permitted voltage	Protection between wires and earth and/or casing – type of protection, permitted voltage
APC..., APR...	68V DC (39V DC for Exi version)	Plasma surge arresters - 230V DC (Not applicable to Exi, Exd version).

9.3.3. The voltage in the protective elements must not exceed the maximum permitted values given in columns 2 and 3 of the table.



The insulation test voltages (500V AC or 750V DC) given in 5.1.1 refer to transmitters plasma surge arresters - such protection is not used in Exi versions of transmitters.

9.4. Earthing

The transmitters are fitted with internal and external earth terminals.

10. SETTING AND REGULATION

APC..., APR... transmitters are factory calibrated to the range stated in the order or to the basic range.

After installation, the transmitter's zero-point may move and require adjustment.

This applies particularly in cases where the measurement range is small, where the impulse lines are filled with a separating liquid or where **APC..., APR...** transmitters are used with remote diaphragm seals.

10.1. Transmitter Range, Basic Range. Definitions

10.1.1. The maximum range of pressure, or differential pressure, which the transmitter can measure is called the “**basic range**” (for specifications of basic ranges see section 5.2.1, 5.3.1, 5.3.2, 5.4.1, 5.5.1).

The width of the basic range is the difference between the upper and lower limits of the basic range.

The internal characteristic conversion curve for the basic range is coded in the transmitter's memory.

This is the reference curve used when making any adjustments which affect the transmitter's output signal.

10.1.2. When the transmitter is in use the term “**set range**” is used. The set range is the range whose lower end-point corresponds to an output current of 4mA and whose upper end-point corresponds to a current of 20mA (or 20mA and 4mA respectively when the conversion curve is inverted).

The set range may cover the whole of the basic range or only a part of it.

The width of the set range is the difference between its upper and lower end-points.

The transmitter may be set to any range within the basic range of pressure values, subject to the restrictions set out in the table in section 5.2.1, 5.3.1, 5.3.2, 5.4.1, and 5.5.1.

10.2. Configuration and Calibration

10.2.1. The transmitter has features which enable metrological and identification parameters to be set and altered. The configurable metrological parameters affecting the transmitter's output current include the following:

- a) unit in which the measured pressure is expressed on the display
- b) upper end-point of the set range
- c) lower end-point of the set range
- d) time constant
- e) type of characteristic curve: linear or radical

Parameters of an informational nature which cannot be altered include the following:

- f) upper limit of the basic range
- g) lower limit of the basic range
- h) minimum range

10.2.2. Other identification parameters, not affecting the output signal, include: device address, device type code, factory identification code, factory device code, number of preambles (3-20), UCS, TSD, program version, electronics version, flags, serial number, label tag, description tag, date tag, message, record number, sensing module number.

The process of setting the parameters listed in 10.2.1 and 10.2.2 is called “**Configuration**”.

10.2.3. It is possible to carry out a “**pressure zeroing**” procedure, for example to compensate for measurement deviation caused by a change in position during the transmitter installation.

The transmitter may also be **calibrated**, by taking readings with the input pressure controlled using a standard device. This process and zero-point adjustment are called “**Calibration**”.

10.2.4. Configuration and Calibration of the transmitter are carried out using an Aplsens KAP communicator, certain Hart communicators or a PC with Hart/RS232 converter and Aplsens “Raport” software.

Together with the “RAPORT” configuration software there is a „INTERVAL LINEARIZATION” software supplied to enable the input of 21-point nonlinear functional characteristics to the transmitter.

A description of the functions of the KAP communicator is contained in the KAP Communicator Operating Manual, and information on the Hart/RS232 converter can be found on the Hart/RS232/01 Converter information sheet.

10.2.5. Local configuration of transmitters

10.2.5.1. Local menu - structure.

EXIT→	[↓][roll down]	[↑][roll up]	→	■ [set]
PVZERO→	[↓][roll down] ←BACK PVZERO	[↑][roll up] ←BACK PVZERO	→	■ [set]
SETLRV→	[↓][roll down] ←BACK SETLRV	[↑][roll up] ←BACK SETLRV	→	■ [set]
SETURV→	[↓][roll down] ←BACK SETURV	[↑][roll up] ←BACK SETURV	→	■ [set]
UNIT→	[↓][roll down] ←BACK INH2O INHG FTH2O MMH2O MMHG PSI BAR MBAR GSQCM KGSQCM PA KPA TORR ATM MH2O4 MPA INH2O4 MMH2O4	[↑][roll up] ←BACK MMH2O4 INH2O4 MPA MH2O4 ATM TORR KPA PA KGSQCM GSQCM MBAR BAR PSI MMHG MMH2O FTH2O INHG INH2O	→	■ [set]

DAMPIN → [set]	[↓][roll down] ←BACK 60 [S] 30 [S] 10 [S] 5 [S] 2 [S] 0 [S]	[↑][roll up] ←BACK 0 [S] 2 [S] 5 [S] 10 [S] 30 [S] 60 [S]	→	■
TRANSF → [set]	[↓][roll down] ←BACK LINEAR SQRT SPECIA SQUARE	[↑][roll up] ←BACK SQUARE SPECIA SQRT LINEAR	→	■
%SQRT → [set]	[↓][roll down] ←BACK 1.0 % 0.8 % 0.6 % 0.4 % 0.2 % 0.0 %	[↑][roll up] ←BACK 0.0 % 0.2 % 0.4 % 0.6 % 0.8 % 1.0 %	→	■
LCD1VR →	[↓][roll down] ←BACK CURREN PERCEN	[↑][roll up] ←BACK PERCEN CURREN	→	■ [set]
LCD2VR →	[↓][roll down] ←BACK PRESS USER SENS_T CPU_T	[↑][roll up] ←BACK CPU_T SENS_T USER PRESS	→	■ [set]
LCD2DP →	[↓][roll down] ←BACK XXXX● XXX●X XX●XX X●XXX X●XXXX	[↑][roll up] ←BACK X●XXXX XX●XXX XXX●XX XXXX●X XXXXX●	→	■ [set]
FACTOR →	[↓][roll down] ←BACK RECALL	[↑][roll up] ←BACK RECALL	→	■ [set]
RESET →	[↓][roll down] ←BACK RESET	[↑][roll up] ←BACK RESET	→	■ [set]
MID_WP →	[↓][roll down] ←BACK ON OFF	[↑][roll up] ←BACK OFF ON	→	■ [set]

If the option of local configuration is active, operator can change transmitter set using buttons being below display. The access to buttons will get after unscrewing the side cover. Then we can also change the display position turning it with 90° angle position. (see fig. 4).

If the option of local configuration is active, operator can change transmitter set using buttons being below display. To enter at the local set change of the work mode, you should press one button and hold its about 4s. If using buttons can't change the transmitter configuration, the local transmitter configuration is switched of and to its switching on is necessary to use the KAP 3 Calibrator.

The buttons are signed with symbols: [↑] [↓] [■]

After pressing by 4 seconds any of buttons there will appear on display "EXIT".

If we will confirm this announcement across pressing and holding button [■] by 1 sec, we will go out from the local change of the MENU set. If we will not confirm, we can move in MENU and change interesting us parameters. The time of pressing [↑] [↓] [■] has to be longer than 1s.

Pressing button [↑] moves up in tree's structure MENU

Pressing button [↓] moves down in tree's structure MENU

Pressing [■] confirms choice and leads change.

EXIT (First announcement which will see after inclusion of Menu Local. If you will confirm this option, you will go out from Local Menu and you will come back to continue of measuring)

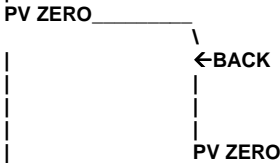

(Return to Local Menu. If you will confirm this option, you will come back to main tree of Local Menu)

(Pressure zeroing. If you will confirm this option, transmitter will confirm the party of command by the "DONE" announcement or the proper number of error will notify.)

SET LRV (The Setting of the range of the set LRV beginning) -(no change of span)

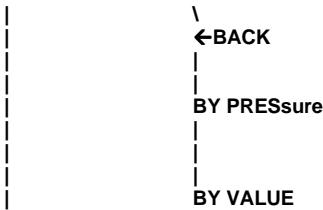

(Return to Local Menu. If you will confirm this option, you will come back to main tree of Local Menu)

(Setting LRV across setting pressure. If you will confirm this option, transmitter will confirm the party of command by the "DONE" announcement or the proper number of error will notify)

(Setting the LRV across inscribing of value.)

(After confirmation will display current LRV value before the passage in mode of edition)



(Choose and confirm sign introduced parameter)

00000 (Introduce in sequence, digit after digit, 5 digital number with point or without point. After confirmation the last 5 digit of the parameter transmitter will confirm the party of command by the "DONE" announcement or the proper number of error will notify. The parameter will be written down in units "UNIT")

SET URV____

(The setting of the end of the set URV range) – (change of span)

↖
←BACK

(Return to Local Menu. If you will confirm this option, you will come back to main tree of Local Menu)

BY PRESSure

(Setting URV across setting pressure. If you will confirm this option, transmitter will confirm the party of command by the "DONE" announcement or the proper number of error will notify)

↖
BY VALUe

(Setting the URV across inscribing of value)

(After confirmation will display current URV value before the passage in mode of edition)

↓

↓
+/-

(Choose and confirm sign introduced parameter)

↓
00000

(Introduce in sequence, digit after digit, 5 digital number with point or without point. After confirmation the last 5 digit of the parameter transmitter will confirm the party of command by the "DONE" announcement or the proper number of error will notify. The parameter will be written down in units "UNIT")

UNIT_____

↖
←BACK

(Return to Local Menu. If you will confirm this option, you will come back to main tree of Local Menu)

(Confirm one of the following characteristics across longer press button **■**. After parameter confirmation transmitter will confirm the party of command by the "DONE")

IN_H2O

IN_HG

FT_H2O

MM_H2O

MM_HG

PSI

BAR

MBAR

G/SQCM

KG/SQCM

PA

KPA

TORR

ATM

M_H2O

MPA

INH20@4

MMH2O@4

DAMPING

←BACK

(Setting of the solid temporary suppression of the process variable)

(Return to Local Menu. If you will confirm this option, you will come back to main tree of Local Menu)

(Confirm one of the following values time constant across longer press button **■**. After parameter confirmation transmitter will confirm the party of command by the "DONE")

- 0 [S]
- 2 [S]
- 5 [S]
- 10 [S]
- 30 [S]
- 60 [S]

TRANSFER

←BACK

(Setting of the current output form)

(Return to Local Menu. If you will confirm this option, you will come back to main tree of Local Menu)

(Confirm one of the following characteristics across longer press button **■**. After parameter confirmation transmitter will confirm the party of command by the "DONE")

- LINEAR
- SQRT
- SPECIAL
- SQUARE

(Linear)
 (square root)
 (user's)
 (square)

% SQRT

←BACK

(Square root characteristic cut-of point setting)

(Return to Local Menu. If you will confirm this option, you will come back to main tree of Local Menu)

(Confirm one of the following percent value across longer press button **■**. After parameter confirmation transmitter will confirm the party of command by the "DONE")

- 0.0 %
- 0.2 %
- 0.4 %
- 0.6 %
- 0.8 %
- 1.0 %

LCD1 VARIABLE

←BACK

(Type of the process variable displayed on LCD1)

(Return to Local Menu. If you will confirm this option, you will come back to main tree of Local Menu)

(Confirm one of the following option across longer press button **■**. After parameter confirmation transmitter will confirm the party of command by the "DONE")

- CURRENT
- PERCENT

(On LCD1 will displayed current value in current loop)

(The percent value output signal will displayed on LCD1)

LCD2 VARiable

←BACK

(Type of the process variable displayed on LCD2)
(Return to Local Menu. If you will confirm this option, you will come back to main tree of Local Menu)
(Confirm one of the following option across longer press button **■**. After parameter confirmation transmitter will confirm the party of command by the "DONE")

PRESSURe

(The pressure value will displayed on LCD2)

USER

(The user's units will displayed on LCD2)

UNIT

(The current unit or user's unit alternately with process variable will displayed on LCD2)

SENS_T*

(The pressure sensor temperature in Celsius degrees will displayed on LCD2)

NO UNIT

(The current unit or user's unit alternately with process variable will not displayed on LCD2)

CPU_T*

(The main electronics board temperature in Celsius degrees will displayed on LCD2)

*) UNIT and NO UNIT sequence is enabled to the older solutions of transmitters , in solutions since 2011: SENS T and CPU T sequence is applicable.

LCD2 DP

←BACK

(The process variable point position on LCD2)
(Return to Local Menu. If you will confirm this option, you will come back to main tree of Local Menu)
(Confirm one of the following option across longer press button **■**. After parameter confirmation transmitter will confirm the party of command by the "DONE")

XXXXX•

XXXX•X

XXX•XX

XX•XXX

•XXXXX

FACTORY

←BACK

(Come back to factory setting)
(Return to Local Menu. If you will confirm this option, you will come back to main tree of Local Menu)
(Confirm the command as bellow across longer press button **■**. After parameter confirmation transmitter will confirm the party of command by the "DONE")

RECALL

|RESET_____

 ←BACK
 RESET

(The program enforcement of the transmitter restart)

(Return to Local Menu. If you will confirm this option, you will come back to main tree of Local Menu)

(Confirm the command as below across longer press button . After parameter confirmation transmitter will confirm the party of command by the "DONE")

for transmitters with the display in accordance with EN 12405-1 (MID)

MID_WP_____

 ←BACK
 ON

(Lock modify the parameters associated with MID)

(Back to the Local Menu. If you approve this option, return back to the main menu Tree Local)

(Submit one of the following through constant pressing. Once approved, the parameter transmitter will confirm receipt of the command message "DONE")

OFF

(Lock Activation parameters affecting the metrology)

(Turns lock parameters affecting the metrology)

10.2.5.2. LCD display configuration - installed till 2010.

The LCD display configuration can do in dependence from needs. Changes of the display options in local MENU are possible using buttons or remote way using communicator, or the PC software. If it is necessary the display switching off is also possible. The display switching of function is possible with using communicator or PC software only.

The APC..., APR... transmitter display exterior is as below.

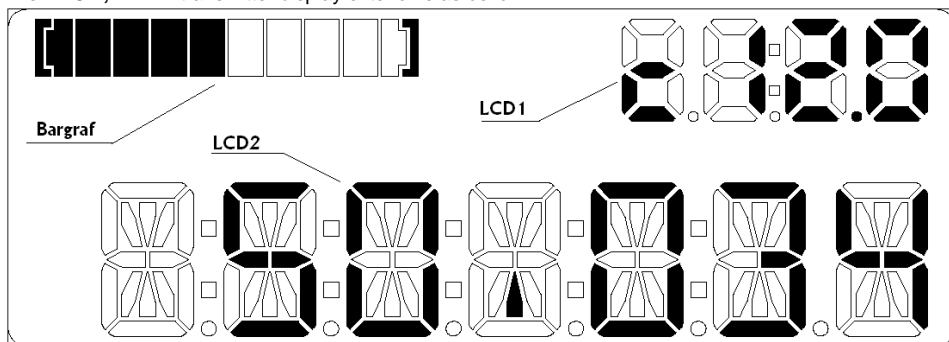

There 3 main displays are visible:

- **Bargraf (display line)** – the current output grade line guidance display. At 0% output guidance, the line units are not blacked. As the guidance is rise the next units will blacked. One unit correspond to 10% guidance. At 100% guidance all line units will blacked.
- **LCD1** – the current or guidance percent preset range display. In accordance with display configuration the current value in 4 -20 mA current loop, or percent guidance preset range is possible to display. When current is displayed , symbol „c” before value is visible.

LCD2 – the measured pressure digital value display; the calibrated pressure value according to user's units display; the process variable units, user's units display, the pressure sensor temperature (medium), the electronics board temperature; the MENU announcement and other information or warning announcement display.

In the case the digital pressure value or the calibrated pressure value display, the sign „-“, can be visible before displayed value. The decimal point position is possible to set in local MENU or remotely.

In the case of display overflowing (when the displayed value will exceed the „99999“) the „COMMA“ displays. When the pressure value limits will exceeded the „UNDER“ or „OVER“ are displayed depending on exceeding direction. The pressure unit or user's unit can be displayed alternatingly with digital value displaying in 10s indicate digital value cycle, or 1s indicate digital value cycle. If it is necessary the display unit switching off in local MENU is possible, or with communicator, or PC software using.

The transmitter makes possible rescale on the user's individual the pressure value. To make this is necessary with using communicator or PC software write the corresponding to beginning and to end values of setting range as well as write the own unit name. After activating user's mode the rescale value will be visible on display.

Local display is equipped in backlight, switching on and switching off with jumper on electronic board.

10.2.5.3. Setting up a local LCD display - the display in accordance with MID installed since 2011.

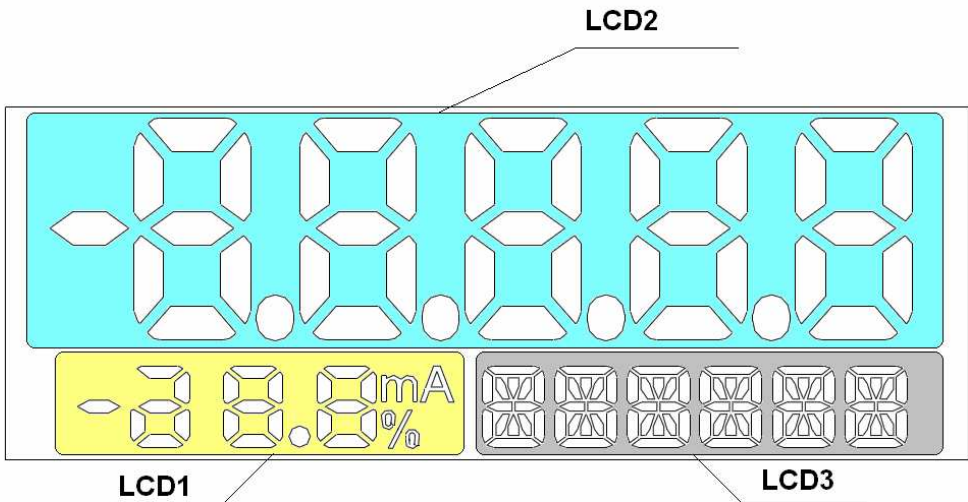

There 3 main displays are visible:

- **LCD1** – the current or guidance percent preset range display. In accordance with display configuration the current value in 4 -20 mA current loop, or percent guidance preset range is possible to display.
- **LCD2** – the measured pressure digital value display; the calibrated pressure value according to user's units display; the process variable units or user's units display; the MENU announcement and other information or warning announcement display. In the case the digital pressure value or the calibrated pressure value display, the sign „-“, can be visible before displayed value. The decimal point position is possible to set in local MENU or remotely. The pressure unit or user's unit can be displayed. The transmitter makes possible rescale on the user's individual the pressure value. To make this is necessary with using communicator or PC software write the corresponding to beginning and to end values of setting range as well as write the own unit name. After activating user's mode the rescale value will be visible on display.
- **LCD3** – information display. During normal operation is designed for continuous display of the base unit or the user units. In case of errors in the transmitter's work , it displays an error number. In manual mode, the local change settings menu displays options of selecting the setting. It also displays errors related to the implementation of commands in the local menu of the settings change.

- **Display backlighting** - Local display is equipped in backlight, switching on and switching off with jumper on electronic board. How to handle display backlight is shown in Figure 4a. Figure 4 shows how to change the display position by rotation.

Warning!

Exceeding the basic transmitter measuring range over 50% range in the up or down is indicated by " o V E r " or " u n d E r " in the display LCD2. Such situation is encountered most often when overloaded a difference pressure transmitter, created when the large static pressure compared to the pressure range will blockage or a leak in one of the capillaries.



After configuration it is important to protect the transducers using command HART [247]. During work transmitter should be safe prior to entries. This prevents accidental or intentional changes configurational data. The protection function is accessible in KAP03 communicator, "Raport's" software, as well as, in applying DD or DMT programs libraries.

Descriptions

EXIT	return from the local Menu to the normal operation of the transmitter
UNIT	menu process variable units. Options:
<i>IN_H2O</i>	inches of water at a temperature of 68 °Fahrenheit
<i>IN_HG</i>	inches of mercury at a temperature of 68 °Fahrenheit
<i>FT_H2O</i>	foot of water a temperature of 68 °Fahrenheit
<i>MM_H2O</i>	mm of water at a temperature of 68 °Fahrenheit
<i>MM_HG</i>	mm of mercury at 0 °C
<i>PSI</i>	
<i>BAR</i>	bar
<i>MBAR</i>	millibar
<i>G/SQCM</i>	grams per square centimetres
<i>KG/SQCM</i>	kilogram per square centimetres, technical atmosphere
<i>PA</i>	pascal
<i>KPA</i>	kilopascal
<i>TORR</i>	tor (mm Hg)
<i>ATM</i>	physical atmosphere
<i>M_H2O</i>	meter of water at 4 °C
<i>MPA</i>	megapascal
<i>INH2O@4</i>	inch of water at a temperature of 4 °C
<i>MMH2O@4</i>	mm of water at 4 °C
DAMPIN	menu damping of process variable [s]. You can choose 0,2,5,10,30,60 [s]
TRANSF	type of current output characteristic Menu. Options:
<i>LINEAR</i>	linear
<i>SQRT</i>	square root
<i>SPECIA</i>	user's special
<i>SQUARE</i>	square
%SQRT	menu of, point insensitivity of square root characteristics. To select 0%, 0.2%, 0.4%, 0.6%, 0.8%, 1.0% range
PVZERO	pressure zeroing.
SETURV	setting the upper range value by the done pressure
SETLRV	setting the lower range of values set by the done pressure
RESET	reboot your transmitter
LCD1VR	assigning a process variable to LCD1. Options:
<i>CURREN</i>	current in the line in [mA]
<i>PERCEN</i>	percent of the set range - controlling in%
LCD2VR	assigning a process variable to LCD2. Options:
<i>PRESS</i>	pressure value in units UNIT
<i>USER</i>	pressure value in user's units
	Scaling of the user range and record of the user units can be made using a computer or communicator, see → HART command No. 244.245
SENS_T	sensor temperature value in the pressure header in °
CPU_T	CPU electronics board temperature value - in °C
LCD2DP	setting the decimal point position on LCD2. Options:
	XXXXX·
	XXXX·X
	XXX·XX
	XX·XXX
	X·XXXX
	In a situation where the value provided to display on the display LCD2 can not be displayed properly due to the position of the decimal point, this is indicated by displaying the four flashing dots ••••. In this case, you must enter to the local menu setting and move the decimal point respectively to the right.
FACTOR	back to factory settings (removing of current and pressure calibrations).
MID_WP	blocking records / change the parameters associated with transmitter metrology
<i>ON</i>	switch on blocking
<i>OFF</i>	switch of blocking

10.2.6. Local Menu, error reports.

During executing in Local Menu some functions, LCD2 announcement can be displayed on the screen.

The error displaying evidences about no realization of command of Local Menu.

The shortened description of errors announcements is showed below.

ERR_L07	<p>[in_write_protected_mode]. Error will ensue out when we try to change setting in Local Menu, but transmitter is protected before recording. To to make the change of setting with Local Menu using, transmitter has to have the included service of Local Menu as well as switched off protection before record. These parameters modification is possible by using KAP -03 communicator, "RAPORT" program or software using library EDDL.</p> <ul style="list-style-type: none"> • default setting: <table border="0" style="margin-left: 20px;"> <tr> <td>Local Menu service</td> <td>switched on</td> </tr> <tr> <td>protection before record</td> <td>switched off</td> </tr> </table> 	Local Menu service	switched on	protection before record	switched off
Local Menu service	switched on				
protection before record	switched off				
ERR_L09	[applied_process_too_high]. Error will ensue out when given parameter (pressure) exceed admissible value. Zeroing or the range setting verifying is necessary.				
ERR_L10	[applied_process_too_low]. Error will ensue out when given parameter (pressure) will too low. Zeroing or the range setting verifying is necessary.				
ERR_L14	[span_too_small]. Error will ensue out when in result of setting range executing change the width of the range will be smaller than admissible.				
ERR_L16	[access_restricted]. Error will ensue out when the service of Local Menu is switched off, and the user tries to call out the Menu Local service. You should switch on the service of Local Menu with the KAP-03 communicator, "RAPORT" program, or software using library EDDL. Warning!, ERR_L16 announcement can be displayed as well by zeroing attempt of the absolute transmitter .				
WNG_L14	[WARNING!, new Lower Range Value Pushed !] Error will ensue out when the end of range set (the URV) change will cause the change of the range set beginning (LRV).				

10.2.7. Remote configuration

Remote configuration is possible with KAP-XX communicator or PC software. Measuring circuit should be in accordance with the fig. 2.

10.2.8. Configuration of the APR-2200ALW transmitters to measure the level, density of liquid and phase boundary

To simplify the mathematical operations we introduce the density coefficient of the medium $X\rho$.

$$X\rho = \frac{\rho_{\text{medium}} [\text{g/cm}^3]}{\rho_{\text{water at 4}^\circ\text{C}} [\text{g/cm}^3]}$$

Since the density of water at 4°C is 1 g/cm³, the **density coefficient $X\rho$ is numerically equal to the density of the medium expressed in g/cm³**. To determine the hydrostatic pressure of a column of liquid in mm H₂O, it is sufficient to multiply the height of the column h [mm] by the density coefficient of the liquid $X\rho$. Since it is easy to determine the hydrostatic pressure in mm H₂O and the transmitter can be configured in those units, in the descriptions of measurement methods given below we will make use of pressures expressed in mm H₂O and the density coefficient $X\rho$.

Configuration of the APR-2200ALW transmitters to measure the level of liquid in a tank.

The measurement task:

To convert a variation in the level of a liquid with density $\rho = 0.87 \text{ g/cm}^3$ between 0 and h_{max} to a variation in the output signal from 4 to 20 mA.

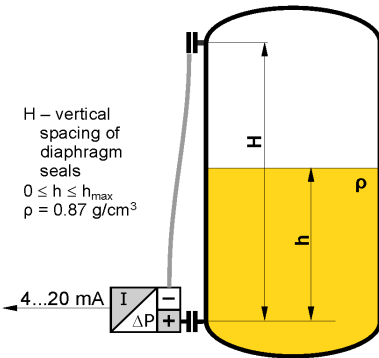

1. Install the transmitter in its working position on an empty tank.
2. Make the electrical connections of the transmitter, providing for the ability to use HART communication.
3. Connect the KAP-01 communicator, identify the transmitter and select the "configuration" function.

4. On the configuration menu select the "Reranging" procedure.
5. On the "Reranging" menu:
 - a) change the units of measurement to mm H₂O at 4°C;
 - b) enter the values for the start ($X\rho \times h_{\text{min}}$ [mm]) and end ($X\rho \times h_{\text{max}}$ [mm]) of the measurement range, namely 0 and ($0.87 h_{\text{max}}$ [mm]) respectively;
 - c) to compensate for the hydrostatic pressure of the manometric fluid, the start of the measurement range should be set using regulated pressure; when subject to the action of only the manometric fluid (empty tank) the transmitter will shift the start and end-points of the range, compensating for the value of that pressure.

When the transmitter has been configured in this way it is ready to be used to carry out the given measurement task.

If it is not possible to empty the tank to configure the transmitter, the hydrostatic pressure of the manometric fluid should be calculated by multiplying the vertical spacing of the diaphragm seals by the density coefficient of the oil in the capillaries. This pressure should be taken into account when entering the values for the start and end of the range:

$$\text{Start [mm H}_2\text{O]} = -H [\text{mm}] \times X\rho_{\text{oil}}$$

$$\text{End [mm H}_2\text{O]} = h_{\text{max}} [\text{mm}] \times X\rho_{\text{measured liquid}} - H [\text{mm}] \times X\rho_{\text{oil}}$$

$$\rho_{\text{oil}} \text{ for DC-550 oil is equal to } 1.068 \text{ g/cm}^3$$

$$\rho_{\text{oil}} \text{ for AK-20 oil is equal to } 0.945 \text{ g/cm}^3$$

Configuration of the APR-2200ALW transmitters to measure density of liquids.

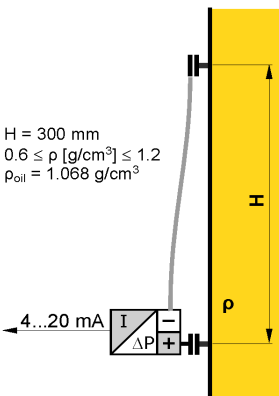

The measurement task:

To convert a variation in liquid density from $\rho_{\text{min}} = 0.6 \text{ g/cm}^3$ to $\rho_{\text{max}} = 1.2 \text{ g/cm}^3$ to a variation in the output signal from 4 to 20 mA, with the vertical spacing of the diaphragm seals equal to $H = 3000 \text{ mm}$. The sealing system is filled with DC-550 oil with density $\rho_{\text{oil}} = 1.068 \text{ g/cm}^3$.

1. Calculate the value of the start of the range as follows:
 $H_{[\text{mm}]} \times (X\rho_{\text{min}} - X\rho_{\text{oil}}) = 3000 \times (0.6 - 1.068) = -1404 [\text{mm H}_2\text{O}]$
2. Calculate the value of the end of the range as follows:
 $H_{[\text{mm}]} \times (X\rho_{\text{max}} - X\rho_{\text{oil}}) = 3000 \times (1.2 - 1.068) = 396 [\text{mm H}_2\text{O}]$
3. Set the zero point of the transmitter with the diaphragm seals positioned at the same level.
4. Install the transmitter in its working position.
5. Make the electrical connections to the transmitter, providing for the possibility of using HART communication.

6. Connect the KAP communicator, identify the transmitter and select the "configuration" function.
7. On the configuration menu select "Reranging" procedure.
8. On the "Reranging" menu:
 - a) change the measurement units to mm H₂O at 4°C;
 - b) enter the calculated values for the start (-1404) and end (396) of the range.

When the transmitter has been configured in this way it is ready to be used to carry out the given measurement task.

Note: If it is possible to fill the space between the seals with a liquid whose density corresponds to the start of the measurement range, the start of the range of the transmitter can be set using regulated pressure.

Measurement of phase boundary

The height of the phase boundary of liquids of different densities is determined by measuring the average density of the medium between the seals.

Example:

Calculate the measurement range start and end points for an APR-2200 transmitter configured to measure phase boundary height in the range 0–1000 mm between liquids of density $\rho_1 = 0.7 \text{ g/cm}^3$ and $\rho_2 = 1.0 \text{ g/cm}^3$, where the vertical spacing of the seals $H = 1600 \text{ mm}$. The sealing system uses DC-550 oil with a density of 1.068 g/cm^3 .

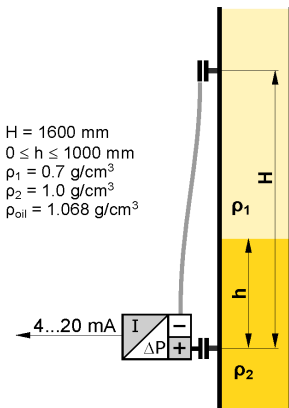

To determine the start of the measurement range, calculate the pressure difference at the transmitter when the tank is filled with the lighter liquid only:

$$1600 \text{ [mm]} \times (0.7 - 1.068) = -588.8 \text{ [mm H}_2\text{O]}$$

To determine the end-point of the range, add the increase in pressure resulting from the appearance of a 1 metre column of the heavier liquid:

$$-588.8 \text{ [mm H}_2\text{O]} + (1.0 - 0.7) \times 1000 \text{ [mm]} = -288.8 \text{ [mm H}_2\text{O]}$$

Additional remarks

The settings of the transmitter can be adjusted with reference to laboratory results from density measurements carried out on samples of the liquid being measured. This is most often necessary when the measurement takes place in a pipeline segment where the flow velocity of the measured liquid reaches several m/s.

Increasing the vertical spacing of the diaphragm seals widens the range and often improves measurement accuracy.

In planning the spacing of the diaphragm seals, ensure that the pressure difference at the transmitter lies within the basic range.

The maximum vertical spacing of the diaphragm seals (H) depends on the transmitter's basic range and the boundary values for the density of the measured liquid (ρ_{\min} ; ρ_{\max}).

If $\rho_{\min} < \rho_{oil} < \rho_{\max}$, the seal spacing H should satisfy the following conditions:

$$H \text{ [mm]} \leq \frac{\text{lower boundary of range [mm H}_2\text{O}]}{X\rho_{\min} - X\rho_{oil}}$$

$$H \text{ [mm]} \leq \frac{\text{upper boundary of range [mm H}_2\text{O}]}{X\rho_{\max} - X\rho_{oil}}$$

Example:

Determine the maximum vertical spacing of the seals for the APR-2200 / -10...10 kPa transmitter when measuring the density of liquid between 0.6 and 1.2 g/cm^3 . The sealing system uses AK-20 silicone oil with a density of 0.945 g/cm^3 .

The lower boundary of the range of the transmitter is -10 kPa = -1020 mm H₂O

$$H \text{ [mm]} \leq \frac{-1020}{0.6 - 0.945} \Rightarrow H \text{ [mm]} \leq \frac{-1020}{-0.345} \Rightarrow$$

$$H \text{ [mm]} \leq 2957$$

The upper boundary of the range of the transmitter is +10 kPa = 1020 mm H₂O

$$H \text{ [mm]} \leq \frac{1020}{1.2 - 0.945} \Rightarrow H \text{ [mm]} \leq \frac{1020}{0.255} \Rightarrow$$

$$H \text{ [mm]} \leq 4000$$

In the example, both conditions are satisfied when the spacing of the seals is not more than 2957 mm.

10.2.9. Configuration of the APR-2200YALW smart level probes

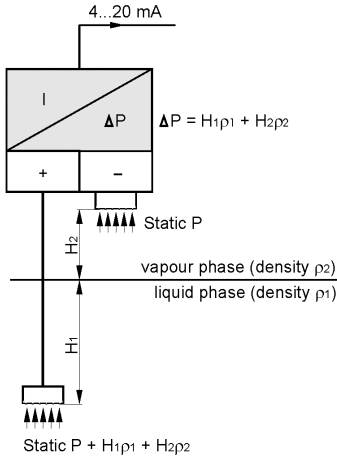

Principles of operation

Measurement is carried out using an APR-2000 differential pressure transmitter, enabling compensation for static pressure in the tank. The value processed is just the hydrostatic pressure of the medium measured at the level of the diaphragm of the lower seal. This pressure is the sum of the hydrostatic pressures of the liquid and vapour phases of the medium. In most practical measurement situations the density of the vapour phase is negligibly small, and therefore the measured hydrostatic pressure relates only to the height of the liquid phase column and can be taken as representing the level of the surface of the liquid phase. For media where the density of the vapour phase is significant (e.g. propane) the level found by the method described can be treated as the theoretical level of the liquid level obtained by adding the actual liquid phase to the condensed vapour phase.

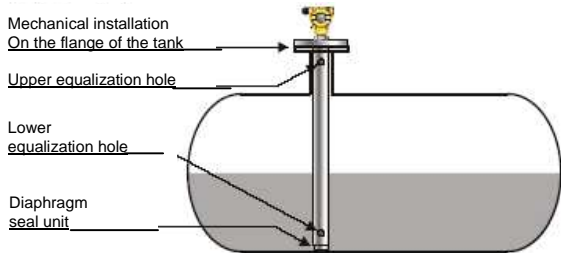

Configuration example

To convert a rise in the level of liquid with density 0.87 from 0 to 3200 mm to a current change from 4 to 20 mA.

1. Install the transmitter in working position, place the seal at the appropriate height (tank empty).
2. Calculate the width of the measurement range in mm H₂O (4°C): $3200 \text{ mm} \times 0.87 \text{ g/cm}^3 = 2784 \text{ mm H}_2\text{O}$.
3. Using the communicator, set the transmitter to use the units **mm H₂O at 4°C**.
4. To determine the start of the measurement range, read off via the communicator the hydrostatic pressure produced by the manometric fluid in the capillary (e.g. **-4250 mm H₂O**).
5. To determine the end-point of the measurement range, add the value -4250 mm H₂O and the width of the measurement range $-4250 \text{ mm H}_2\text{O} + 2784 \text{ mm H}_2\text{O} = \mathbf{-1466 \text{ mm H}_2\text{O}}$.
6. Using the communicator enter the calculated start (**-4250 mm H₂O**) and end-point (**-1466 mm H₂O**) of the measurement range and send as a block to the transmitter. After receiving these parameters the transmitter will perform measurements as required.

11. INSPECTIONS AND SPARE PARTS.

11.1. Periodic service

Periodic inspections should be made in accordance with the regulations to which the user is subject. During inspection, the pressure connectors should be checked for loose connections and leaks, the electrical connectors should be checked with regard to tightness and the state of the gaskets, packing glands, and the diaphragm seals should be checked for tarnishing and corrosion.

Check the characteristic conversion curve by following the procedures for "Calibration" and, where appropriate, "Configuration".

11.2. Periodic services

If the transmitters are installed in a location where they may be exposed to mechanical damage, excess pressure, hydraulic impulses or excess voltage, or the diaphragm may be in danger from sedimentation, crystallization or erosion, inspections should be carried out as required.

Where it is found that the signal in the transmission line is absent or its value is incorrect, a check should be made on the line and its terminal connections.

Check whether the values of the supply voltage and load resistance are correct.

If a communicator is connected to the power supply line of the transmitter, a fault in the line may be indicated by the message "No response" or "Check connection".

If the line is in order, check the operation of the transmitter.



11.3. Cleaning the Diaphragm Seal, Overloading Damage

11.3.1. Sediment and dirt which have formed on the diaphragm in the course of operation must not be removed by mechanical means, as this may damage both the diaphragm and the transmitter itself.

The only permitted method is the dissolving of sediment.

11.3.2. Sometimes transmitters malfunction due to damage caused by overloading, e.g. in case of:



- application of excessive pressure;
- freezing or solidification of the medium;
- action of a hard object, such as a screwdriver, on the diaphragm.

Usually in such cases the symptoms are such that the output current falls below 4mA or rises above 20mA, and the transmitter fails to respond to input pressure.

11.4. Spare parts.

Parts of the transmitter which may be subject to wear or damage and require replacement: cover gasket



Other listed parts, due to the specific features and requirements of explosion-protected devices, may be replaced only by the manufacturer or by a firm authorized by the manufacturer.

12. PACKING, STORAGE AND TRANSPORT.

The transmitters should be packed singly or in sets, in such a way as to protect them from damage during transportation.

The transmitters should be stored in multiple packs under cover, in a place free of vapours and reactive substances, with an air temperature between +5°C and +40°C, and relative humidity of not more than 85%. Transmitters with uncovered diaphragm or seal connectors, stored without packaging, should have covers to prevent damage to the diaphragm.

During transportation, the transmitters should be packed and secured so as to prevent them from shifting.

Any means of transport may be used, provided direct atmospheric effects are eliminated.

13. GUARANTEE

The manufacturer guarantees the proper operation of the transmitters for a period of 24 months from the date of purchase and servicing provided under the guarantee and following the guarantee period. In the case of special versions, the guarantee period shall be agreed by the manufacturer and the user, but shall not be less than 12 months.

14. ADDITIONAL INFORMATION

The manufacturer reserves the right to make constructional and technological changes which do not lower the quality of the transmitters.

14.1. Related documents.

- "KAP– Communicator User's Manual" supplied with the Aplisens communicator.
- Hart/RS232/01 Converter information sheet.
- "Raport" software.
- „INTERVAL LINEARIZATION " software.

15. FIGURES.

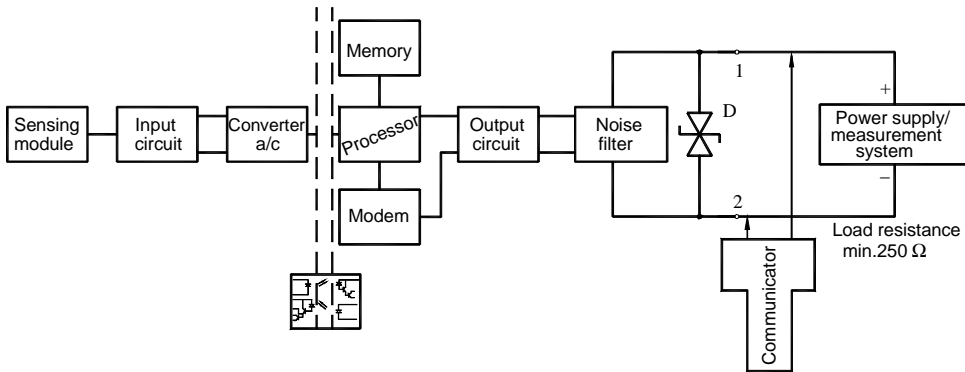

Fig. 1. APC...,APR... transmitters – block diagram.

Communicator or modem electrical connections to transmitter measuring lines.



For successful communication with transmitter the resistance in measuring loop, behind connected device to communication, should be higher than 250Ω. If necessary install the additional resistor in the line. The communicator or modem connecting ways to the measuring loop are presented at diagrams. During increasing of resistance in the measure loop at making the good transmission, is necessary to make sure that the tension falls at sum resistances in the loop don't lower minimum tension at transmitter terminals. (see p.5.1.1)

Fig.2. Electrical connections for APC...,APR... transmitters

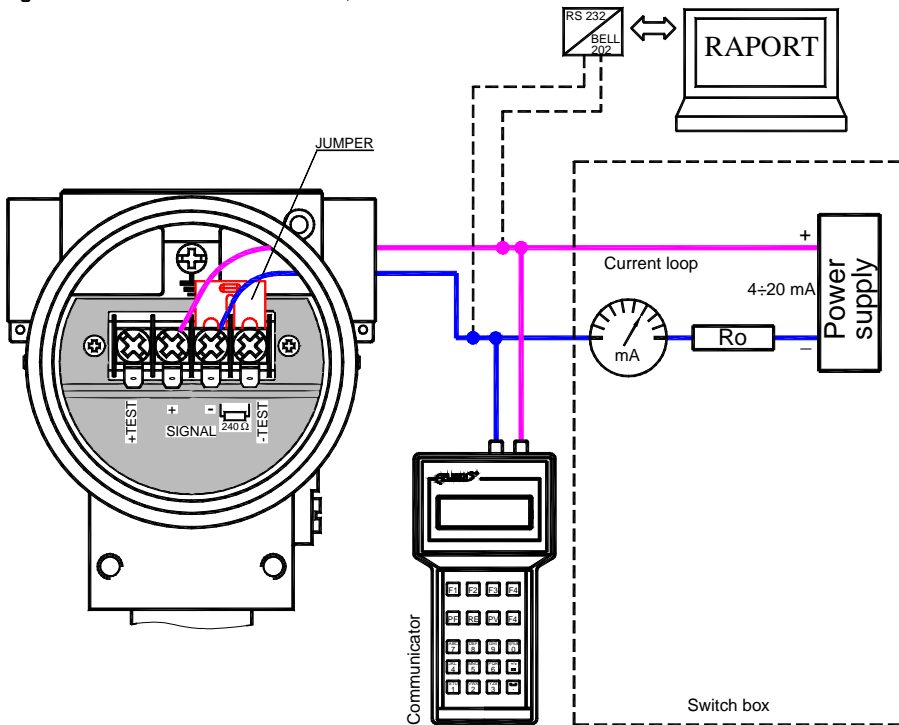

Fig.2a. The link of transmitter and communicator or modem to current line by the switch box (in case of the resistance in current loop is higher than 250Ω).

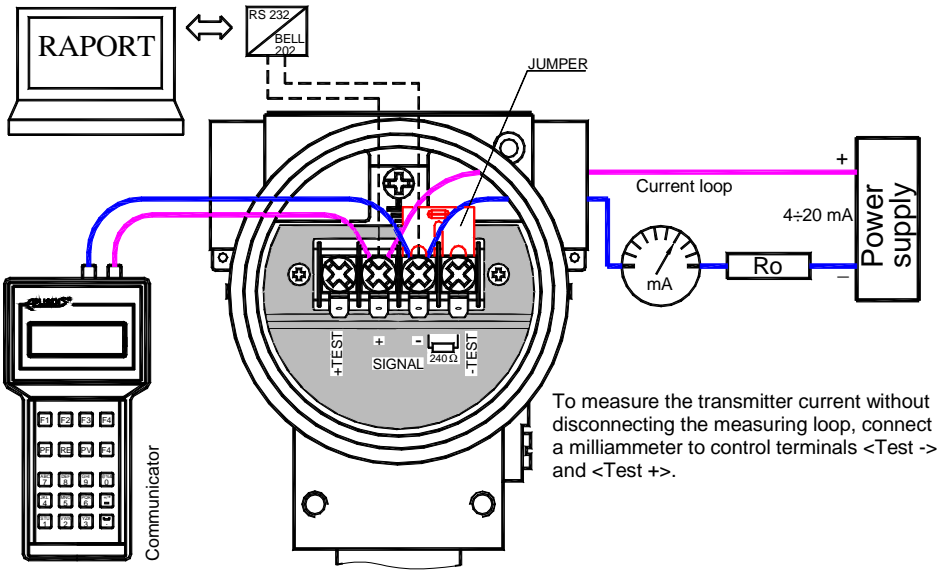

Fig.2b. The link of transmitter and communicator or modem to <SIGNAL+> <SIGNAL-> transmitter terminals in case of the resistance in current loop is **higher than 250Ω**.

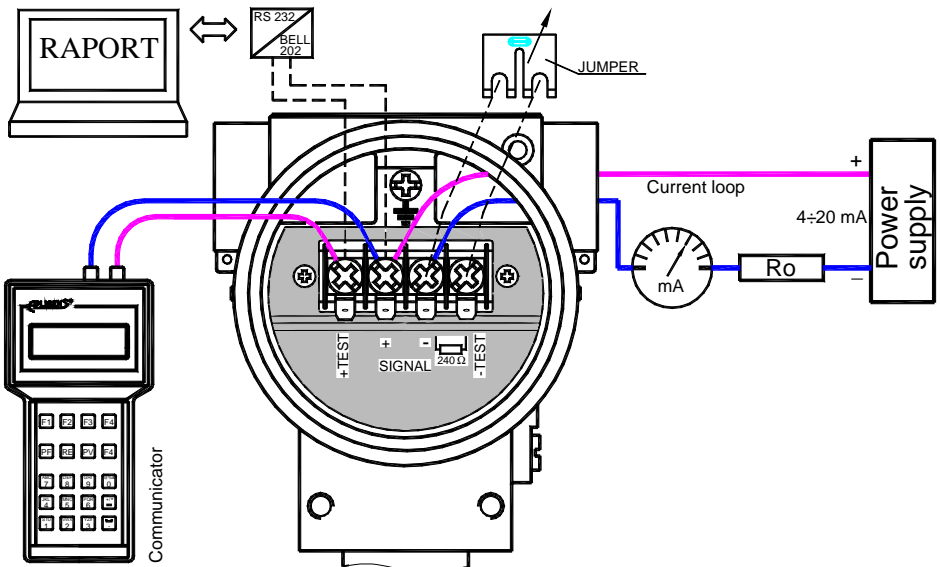

Fig.2c. The link of transmitter and communicator or modem to <SIGNAL+> <TEST+> transmitter terminals in case of the resistance in current loop is **smaller than 250Ω**.

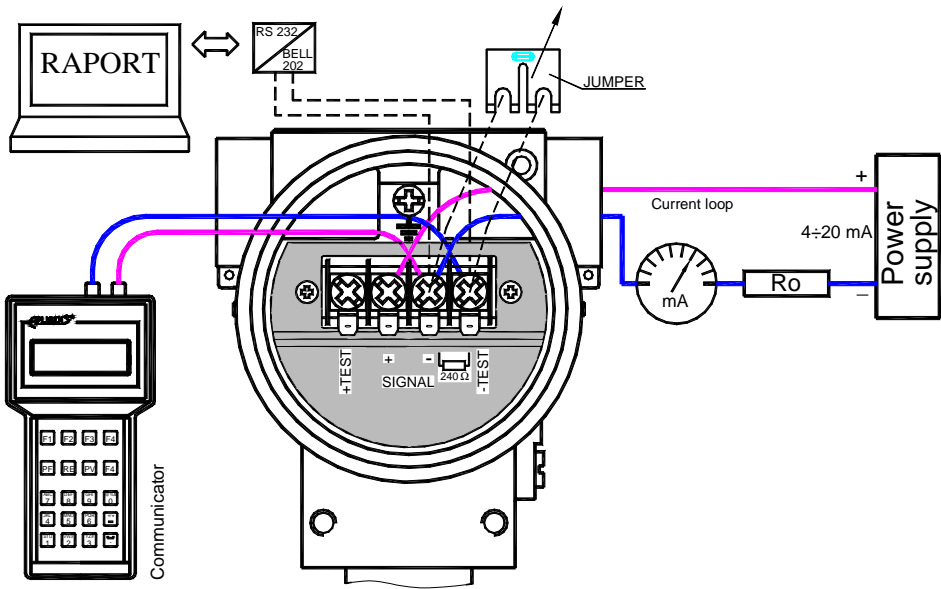

Fig.2d. The link of transmitter and communicator or modem to <SIGNAL+> <SIGNAL-> transmitter terminals in case of the resistance in current loop is smaller than 250Ω.



If R_o in current loop is lower than 250Ω is necessary to connect 240Ω resistor to current loop by remove jumper from <SIGNAL-> and <TEST-> terminals. After communication jumper should cam back at its place.

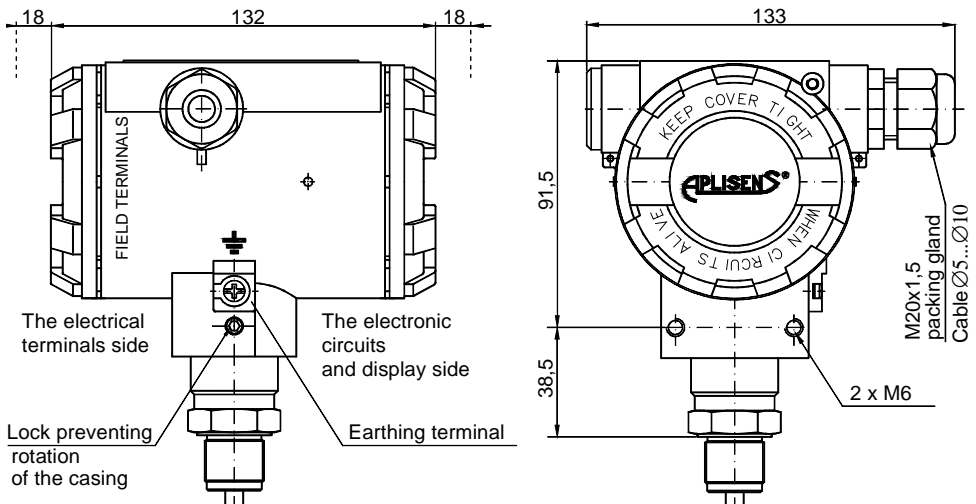

Fig. 3. APC-2000ALW smart pressure transmitter

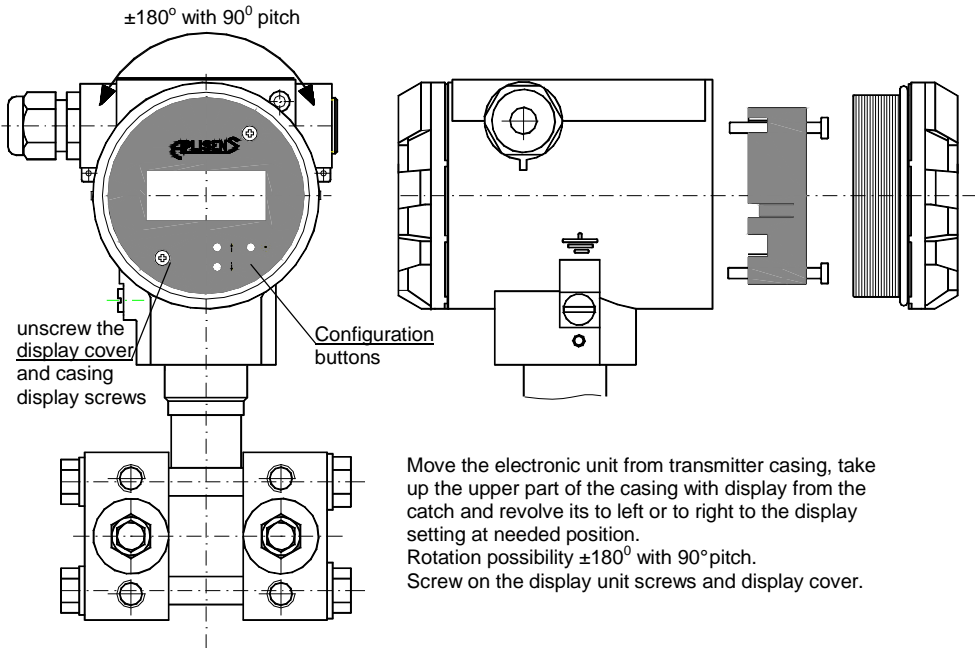

Fig. 4. APC..., APR... display rotation possibility, configuration buttons.



Jumper in radial position (as at photo) –back lighting off; jumper in circular position –back lighting on.

Fig. 4a. Back lighting jumper view at transmitter electric board (unit display back side).

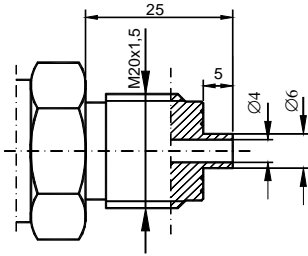

Fig. 5a. M-type connector
with M20x1.5 thread

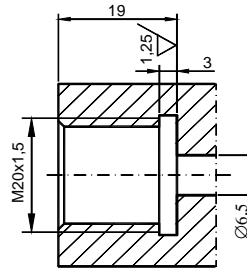

Fig. 5b. Socket for M-type connector

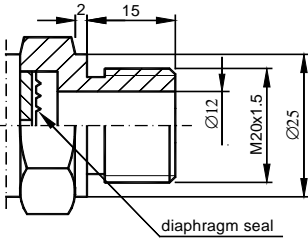

Fig. 6a. P-type connector
with M20x1.5 thread

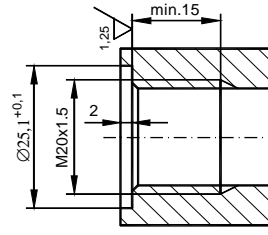

Fig. 6b. Socket for P-type connector

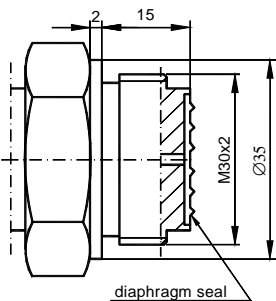

Fig. 7a. CM30x2-type connector
with flush diaphragm
with M30x2 thread,

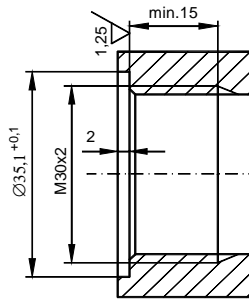

Fig. 7b. Socket for
CM30x2-type
connector.

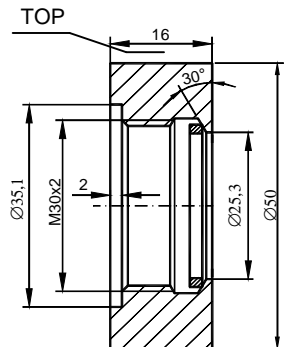

Fig. 7c. Socket for
CM30x2-type connector
Sealing: teflon

Order code Socket CM30x2



The ring in Fig. 7c have to be welded in place with the word TOP upwards

Fig. 5. M-type connector with M20x1.5 thread

Fig. 6. P-type connector with M20x1.5 thread

Fig. 7. CM30x2-type connector with flush diaphragm with M30x2 thread

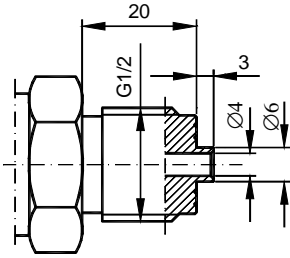

Fig.8a. G1/2 -type connector with G1/2" thread,

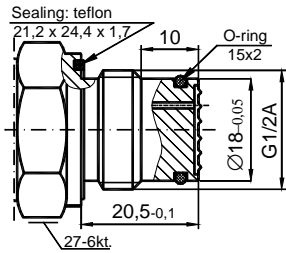

Fig.8c. CG1/2 -type connector with flush diaphragm with G1/2" thread,

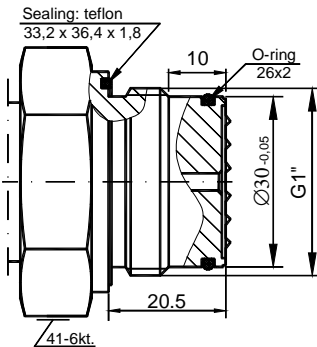

Fig.8e. CG1-type connector with flush diaphragm with G1" thread,

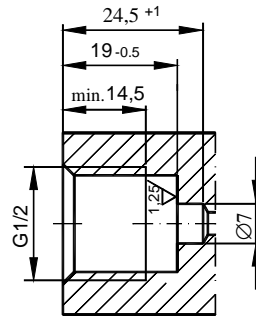

Fig.8b. Socket for G1/2-type connector.

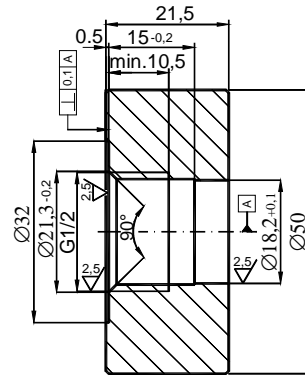

Fig.8d. Socket for CG1/2 - type connector
Order code Socket CG1/2

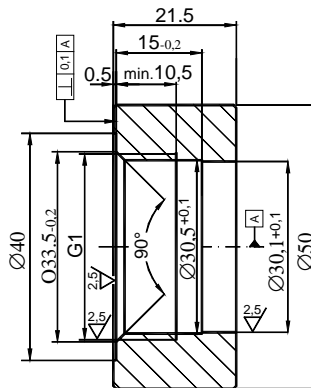

Fig.8f. Socket for CG1 - type connector
Order code Socket CG1

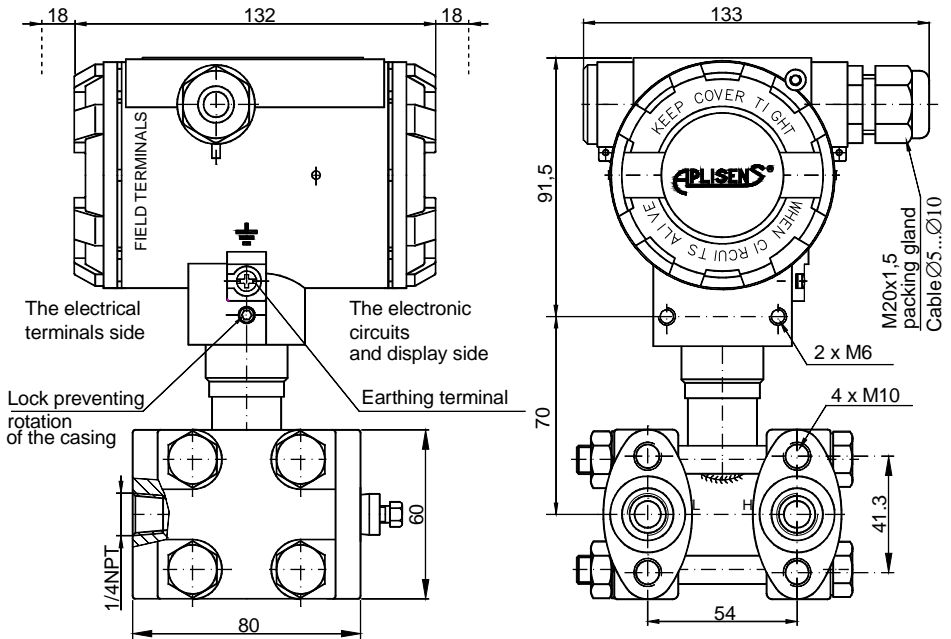

Fig. 9. APR-2000ALW differential pressure transmitter with C type vented covers.

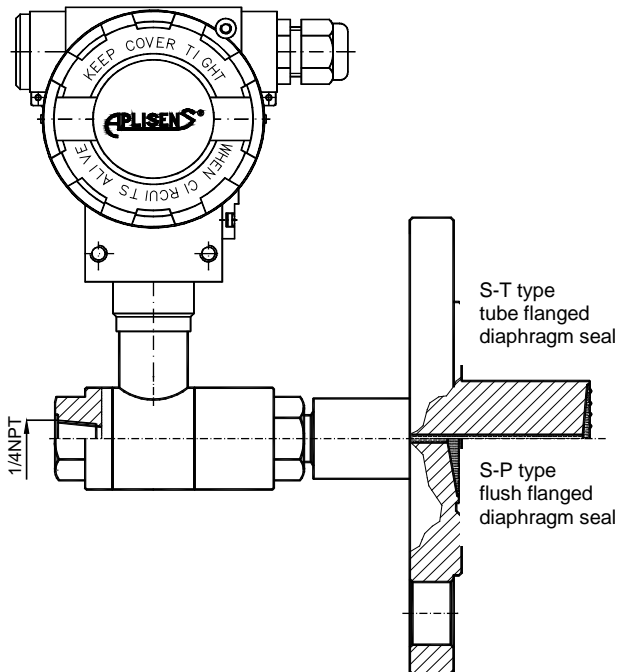
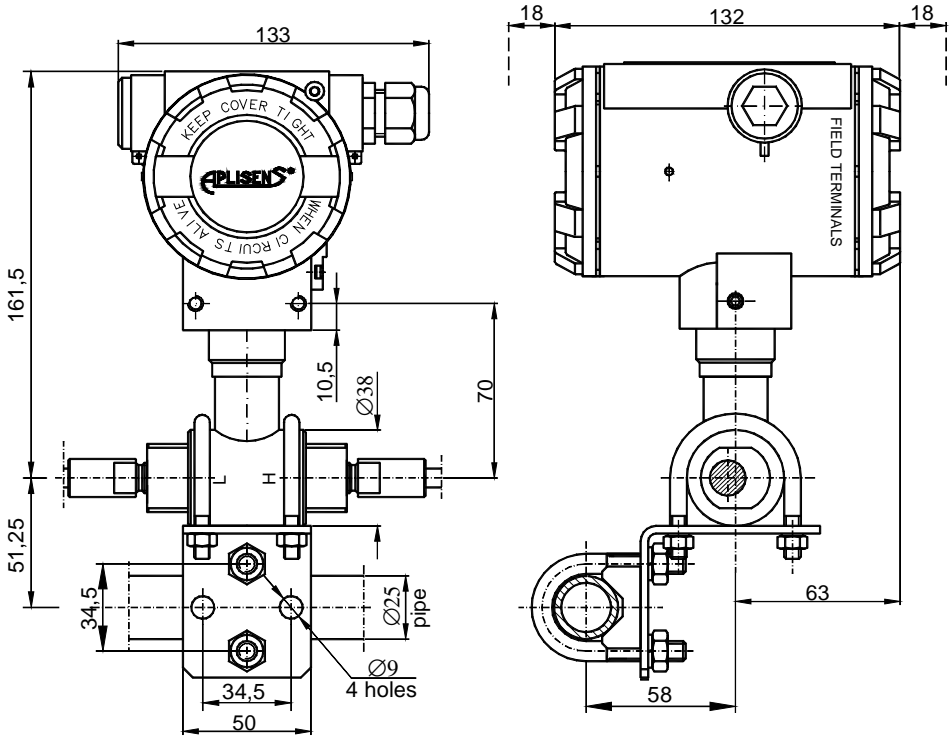

Fig. 10. APR-2000ALW differential pressure transmitter with a single direct diaphragm seal (example).



Assembly Kit ("Mounting bracket $\varnothing 25$ " made by APLISENS) for fitting differential pressure transmitters with P-type connector on a $\varnothing 25$ pipe see catalogue cards "Fitting accessories".

Fig. 11. Example: how to install the APR-2200ALW transmitters with remote diaphragm.

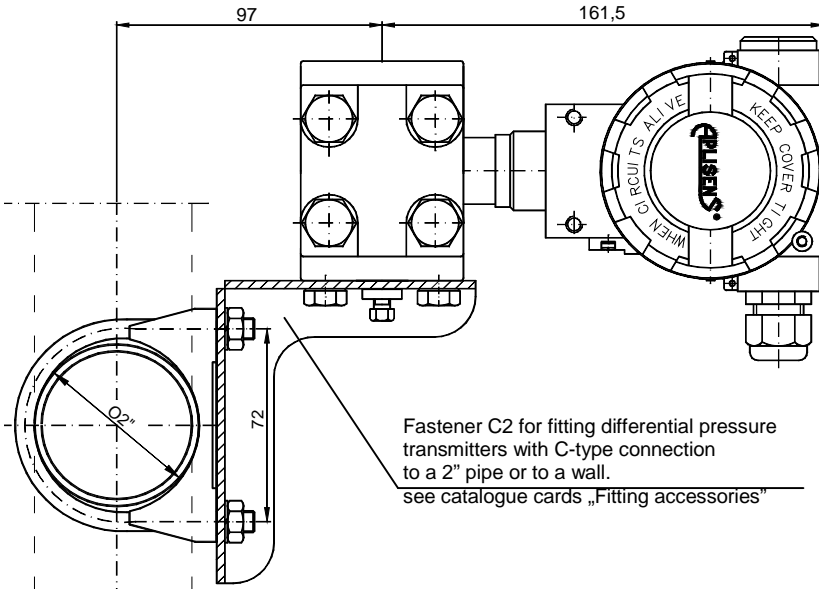

Fig. 12. Example: how to install the APR-2000ALW transmitter on a vertical or horizontal pipe.

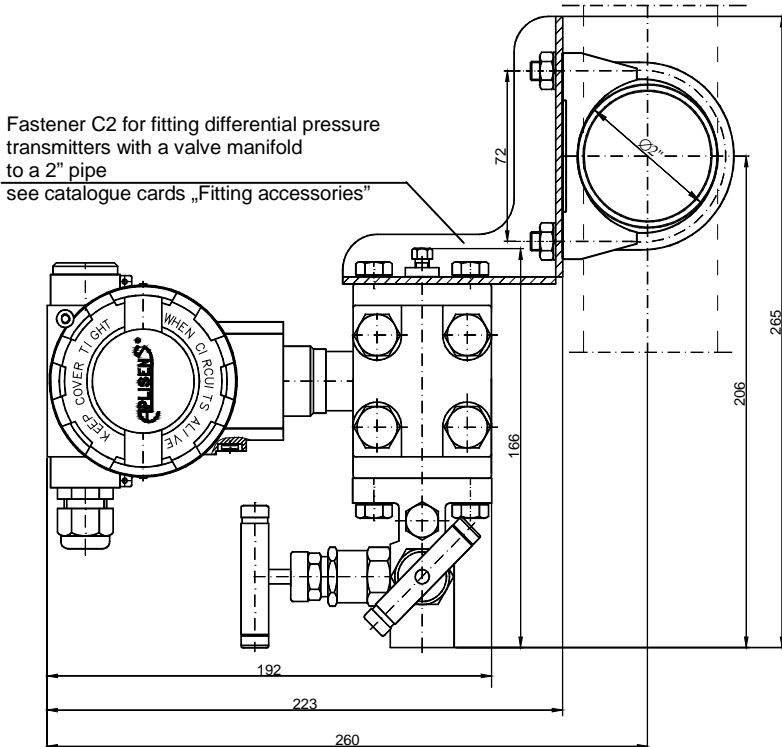

Fig. 13. Example: how to install the APR-2000ALW transmitter with a valve manifold to a 2" pipe.

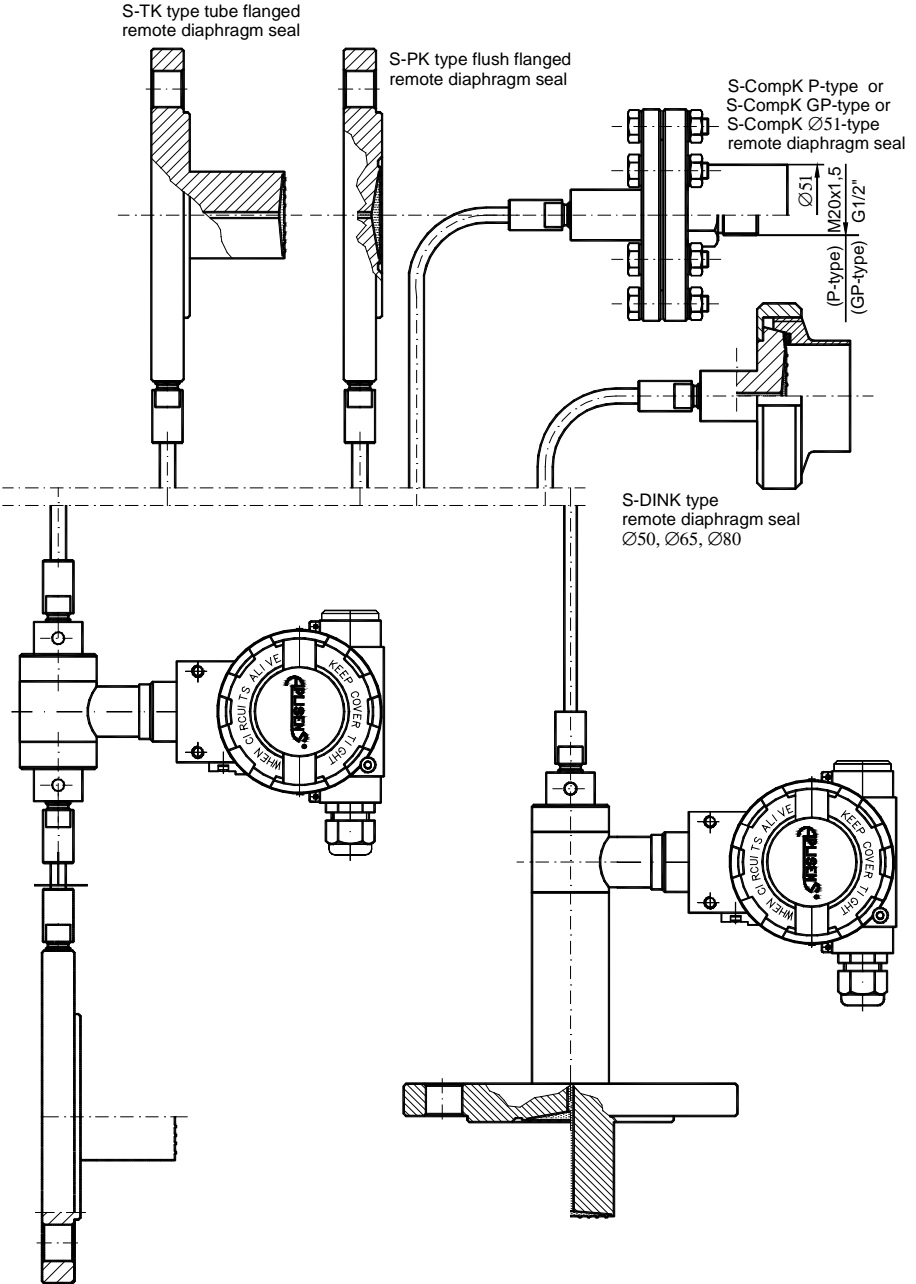

Fig. 14. APR-2200ALW differential pressure transmitter with two remote diaphragm seals (examples)

Fig. 15. APR-2200ALW differential pressure transmitter with direct and remote diaphragm seal (examples)

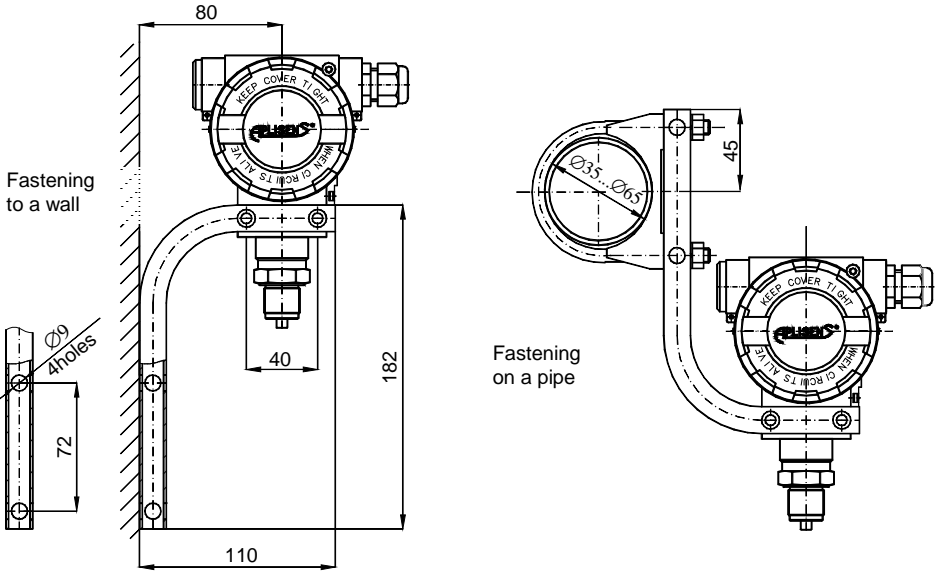

Fig. 16. Example: how to install the APC..., APR... transmitter

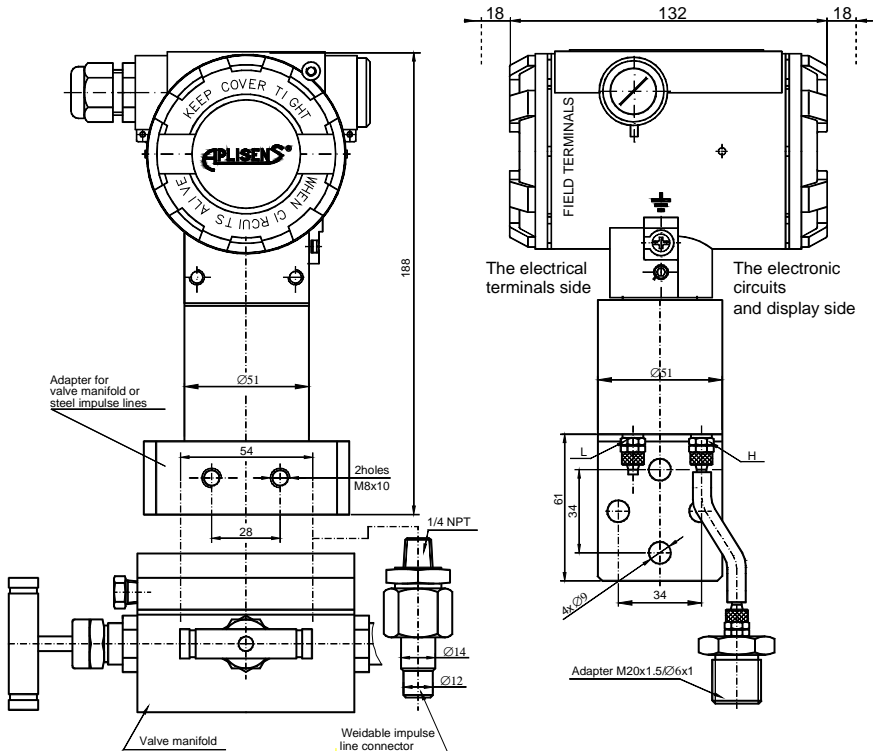

Fig. 17. APR-2000GALW smart differential pressure transmitter for low ranges.

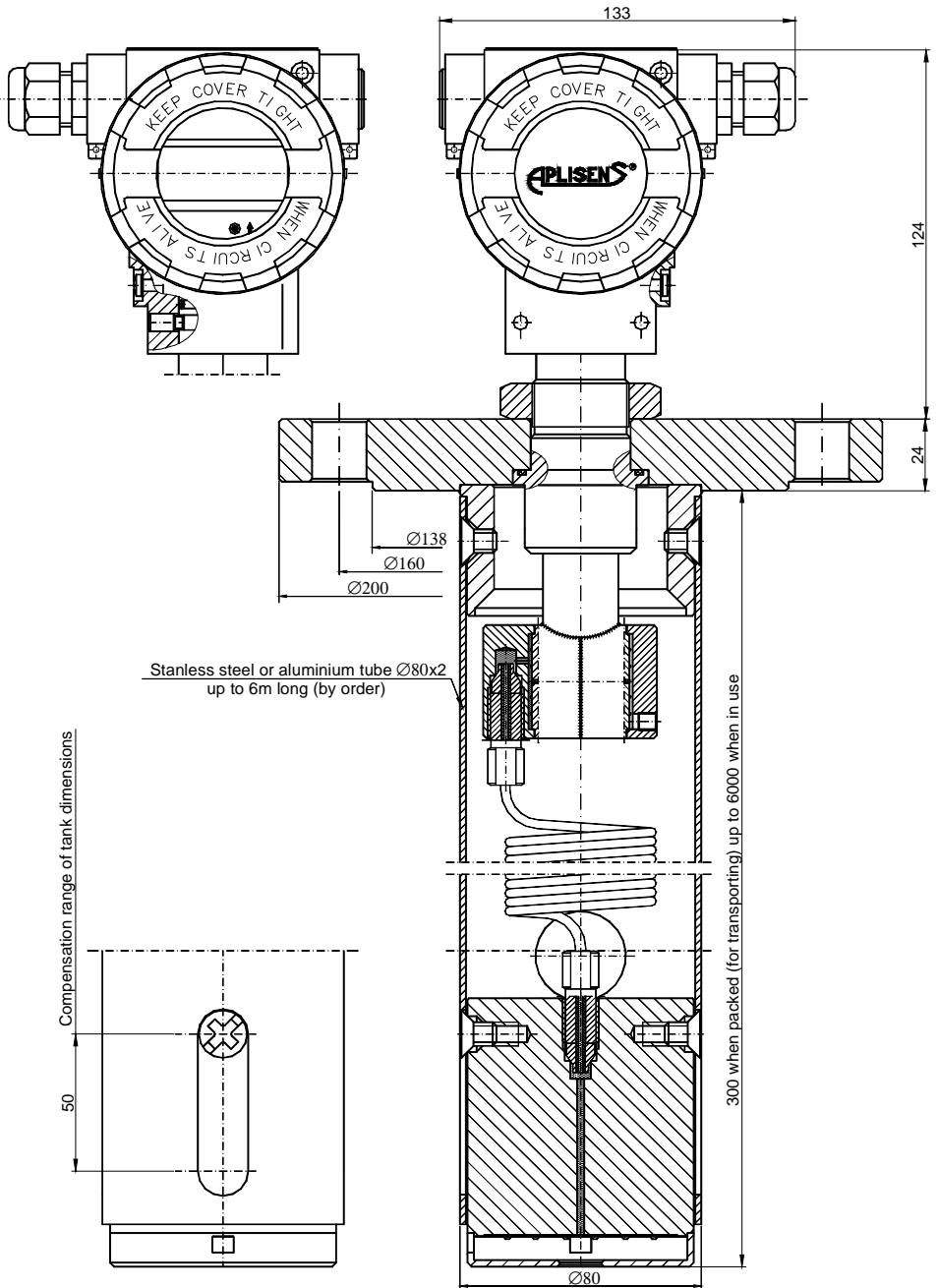

Fig. 18. APR-2000YALW smart level probe for pressure tanks.

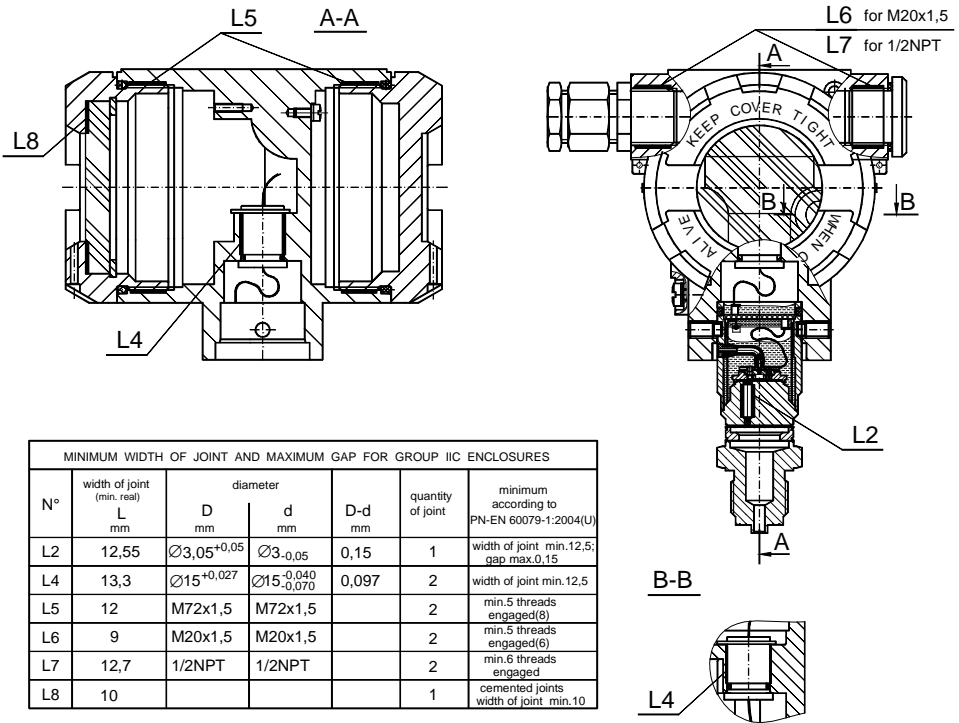

Fig. 19. The explosion - proof joints of APC...,APR... transmitters.

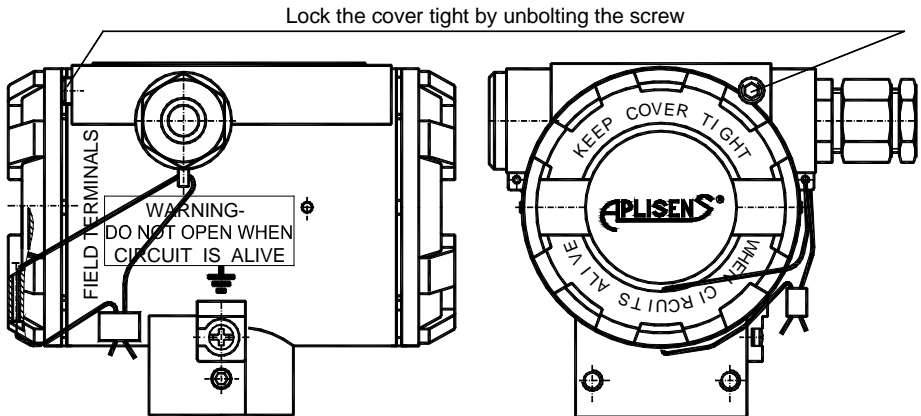

Fig. 20. How to lead the casing of APC...,APR... transmitters

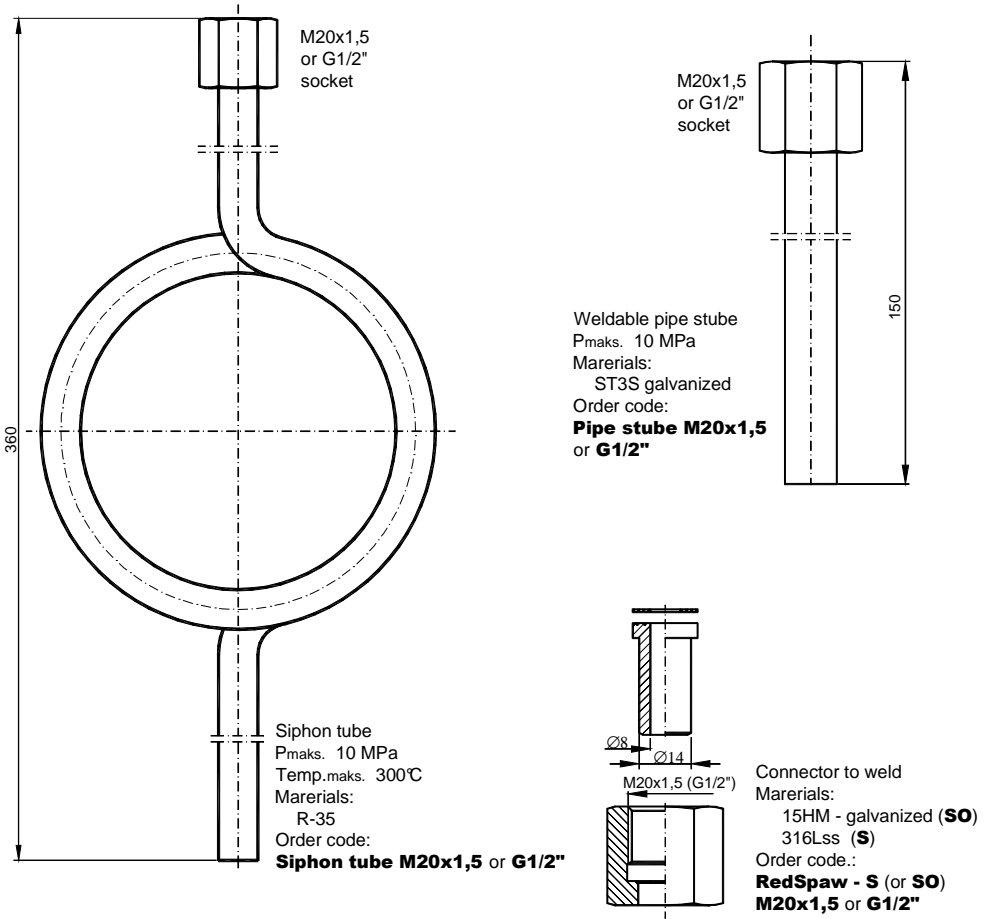

Fig. 21. Additional equipment for fitting of pressure transmitters.

