



# Design Guide

## VLT<sup>®</sup> HVAC Drive FC 102

355–1400 kW





## Contents

<b>1 Introduction</b>	<b>5</b>
1.1 Purpose of the Design Guide	5
1.2 Additional Resources	5
1.3 Document and Software Version	5
1.4 Conventions	5
<b>2 Safety</b>	<b>6</b>
2.1 Safety Symbols	6
2.2 Qualified Personnel	6
2.3 Safety Precautions	6
<b>3 Approvals and Certifications</b>	<b>8</b>
3.1 Regulatory/Compliance Approvals	8
3.2 Enclosure Protection Ratings	10
<b>4 Product Overview</b>	<b>12</b>
4.1 VLT® High-power Drives	12
4.2 Enclosure Size by Power Rating	12
4.3 Overview of Enclosures, 380–480 V	13
4.4 Overview of Enclosures, 525–690 V	16
4.5 Kit Availability	19
<b>5 Product Features</b>	<b>20</b>
5.1 Automated Operational Features	20
5.2 Custom Application Features	22
5.3 Specific VLT® HVAC Drive Features	26
5.4 Basic Cascade Controller	38
5.5 Dynamic Braking Overview	39
5.6 Load Share Overview	40
5.7 Regen Overview	41
<b>6 Options and Accessories Overview</b>	<b>42</b>
6.1 Fieldbus Devices	42
6.2 Functional Extensions	43
6.3 Motion Control and Relay Cards	44
6.4 Brake Resistors	44
6.5 Sine-wave Filters	44
6.6 dU/dt Filters	44
6.7 Common-mode Filters	45
6.8 Harmonic Filters	45
6.9 Enclosure Built-in Options	45

6.10 High-power Kits	47
<b>7 Specifications</b>	<b>48</b>
7.1 Electrical Data, 380–480 V	48
7.2 Electrical Data, 525–690 V	54
7.3 Mains Supply	60
7.4 Motor Output and Motor Data	60
7.5 Ambient Conditions	60
7.6 Cable Specifications	61
7.7 Control Input/Output and Control Data	61
7.8 Enclosure Weights	64
7.9 Airflow for Enclosures E1–E2 and F1–F13	65
<b>8 Exterior and Terminal Dimensions</b>	<b>67</b>
8.1 E1 Exterior and Terminal Dimensions	67
8.2 E2 Exterior and Terminal Dimensions	75
8.3 F1 Exterior and Terminal Dimensions	83
8.4 F2 Exterior and Terminal Dimensions	90
8.5 F3 Exterior and Terminal Dimensions	97
8.6 F4 Exterior and Terminal Dimensions	109
8.7 F8 Exterior and Terminal Dimensions	120
8.8 F9 Exterior and Terminal Dimensions	124
8.9 F10 Exterior and Terminal Dimensions	130
8.10 F11 Exterior and Terminal Dimensions	136
8.11 F12 Exterior and Terminal Dimensions	144
8.12 F13 Exterior and Terminal Dimensions	150
<b>9 Mechanical Installation Considerations</b>	<b>158</b>
9.1 Storage	158
9.2 Lifting the Unit	158
9.3 Operating Environment	159
9.4 Mounting Configurations	160
9.5 Cooling	161
9.6 Derating	162
<b>10 Electrical Installation Considerations</b>	<b>165</b>
10.1 Safety Instructions	165
10.2 Wiring Schematic	166
10.3 Connections	167
10.4 Control Wiring and Terminals	171
10.5 Fuses and Circuit Breakers	177
10.6 Disconnects and Contactors	182

10.7 Motor	183
10.8 Braking	186
10.9 Residual Current Devices (RCD) and Insulation Resistance Monitor (IRM)	188
10.10 Leakage Current	188
10.11 IT Grid	189
10.12 Efficiency	189
10.13 Acoustic Noise	190
10.14 dU/dt Conditions	190
10.15 Electromagnetic Compatibility (EMC) Overview	191
10.16 EMC-compliant Installation	195
10.17 Harmonics Overview	197
<b>11 Basic Operating Principles of a Drive</b>	<b>200</b>
11.1 Description of Operation	200
11.2 Drive Controls	200
<b>12 Application Examples</b>	<b>208</b>
12.1 Wiring Configurations for Automatic Motor Adaptation (AMA)	208
12.2 Wiring Configurations for Analog Speed Reference	208
12.3 Wiring Configurations for Start/Stop	209
12.4 Wiring Configuration for an External Alarm Reset	210
12.5 Wiring Configuration for Speed Reference Using a Manual Potentiometer	210
12.6 Wiring Configuration for Speed Up/Speed Down	211
12.7 Wiring Configuration for RS485 Network Connection	211
12.8 Wiring Configuration for a Motor Thermistor	212
12.9 Wiring Configuration for Cascade Controller	213
12.10 Wiring Configuration for a Relay Set-up with Smart Logic Control	214
12.11 Wiring Configuration for a Fixed Variable-speed Pump	214
12.12 Wiring Configuration for Lead Pump Alternation	214
<b>13 How to Order a Drive</b>	<b>216</b>
13.1 Drive Configurator	216
13.2 Ordering Numbers for Options/Kits	220
13.3 Ordering Numbers for Filters and Brake Resistors	223
13.4 Spare Parts	223
<b>14 Appendix</b>	<b>224</b>
14.1 Abbreviations and Symbols	224
14.2 Definitions	225
14.3 RS485 Installation and Set-up	226
14.4 RS485: FC Protocol Overview	227
14.5 RS485: FC Protocol Telegram Structure	227

---

14.6 RS485: FC Protocol Parameter Examples	231
14.7 RS485: Modbus RTU Overview	232
14.8 RS485: Modbus RTU Telegram Structure	233
14.9 RS485: Modbus RTU Message Function Codes	236
14.10 RS485: Modbus RTU Parameters	236
14.11 RS485: FC Control Profile	237
<b>Index</b>	<b>244</b>

# 1 Introduction

## 1.1 Purpose of the Design Guide

This design guide is intended for:

- Project and systems engineers.
- Design consultants.
- Application and product specialists.

The design guide provides technical information to understand the capabilities of the drive for integration into motor control and monitoring systems.

VLT® is a registered trademark.

## 1.2 Additional Resources

Other resources are available to understand advanced drive operation, programming, and directives compliance.

- The *operating guide* provides detailed information for the installation and start-up of the drive.
- The *programming guide* provides greater detail on how to work with parameters and includes many application examples.
- The *VLT® Safe Torque Off Operating Guide* describes how to use Danfoss drives in functional safety applications. This manual is supplied with the drive when the Safe Torque Off option is present.
- The *VLT® Brake Resistor MCE 101 Design Guide* describes how to select the optimal brake resistor.
- The *VLT® Advanced Harmonic Filters AHF 005/AHF 010 Design Guide* describes harmonics, various mitigation methods, and the operating principle of the advanced harmonics filter. This guide also describes how to select the correct advanced harmonics filter for a particular application.
- The *Output Filters Design Guide* explains why it is necessary to use output filters for certain applications, and how to select the optimal dU/dt or sine-wave filter.
- Optional equipment is available that can change some of the information described in these publications. Be sure to see the instructions supplied with the options, for specific requirements.

Supplementary publications and manuals are available from Danfoss. See [drives.danfoss.com/knowledge-center/technical-documentation/](http://drives.danfoss.com/knowledge-center/technical-documentation/) for listings.

## 1.3 Document and Software Version

This manual is regularly reviewed and updated. All suggestions for improvement are welcome. *Table 1.1* shows the document version and the corresponding software version.

Edition	Remarks	Software version
MG16C3xx	Removed D1h–D8h content and implemented new structure.	5.11

Table 1.1 Document and Software Version

## 1.4 Conventions

- Numbered lists indicate procedures.
- Bullet lists indicate other information and description of illustrations.
- Italicized text indicates:
  - Cross-reference.
  - Link.
  - Footnote.
  - Parameter name, parameter group name, parameter option.
- All dimensions in drawings are in mm (in).
- An asterisk (\*) indicates a default setting of a parameter.

## 2

## 2 Safety

### 2.1 Safety Symbols

The following symbols are used in this guide:

#### **⚠ WARNING**

Indicates a potentially hazardous situation that could result in death or serious injury.

#### **⚠ CAUTION**

Indicates a potentially hazardous situation that could result in minor or moderate injury. It can also be used to alert against unsafe practices.

#### **NOTICE**

Indicates important information, including situations that can result in damage to equipment or property.

### 2.2 Qualified Personnel

Only qualified personnel are allowed to install or operate this equipment.

Qualified personnel are defined as trained staff, who are authorized to install, commission, and maintain equipment, systems, and circuits in accordance with pertinent laws and regulations. Also, the personnel must be familiar with the instructions and safety measures described in this manual.

### 2.3 Safety Precautions

#### **⚠ WARNING**

##### HIGH VOLTAGE

Drives contain high voltage when connected to AC mains input, DC supply, load sharing, or permanent motors. Failure to use qualified personnel to install, start up, and maintain the drive can result in death or serious injury.

- Only qualified personnel must install, start up, and maintain the drive.

#### **⚠ WARNING**

##### LEAKAGE CURRENT HAZARD

Leakage currents exceed 3.5 mA. Failure to ground the drive properly can result in death or serious injury.

- Ensure the correct grounding of the equipment by a certified electrical installer.

#### **⚠ WARNING**

##### DISCHARGE TIME

The drive contains DC-link capacitors, which can remain charged even when the drive is not powered. High voltage can be present even when the warning LED indicator lights are off. Failure to wait 40 minutes after power has been removed before performing service or repair work can result in death or serious injury.

1. Stop the motor.
2. Disconnect AC mains and remote DC-link supplies, including battery back-ups, UPS, and DC-link connections to other drives.
3. Disconnect or lock motor.
4. Wait 40 minutes for the capacitors to discharge fully.
5. Before performing any service or repair work, use an appropriate voltage measuring device to make sure that the capacitors are fully discharged.

#### **⚠ WARNING**

##### FIRE HAZARD

Brake resistors get hot during and after braking. Failure to place the brake resistor in a secure area can result in property damage and/or serious injury.

- Ensure that the brake resistor is placed in a secure environment to avoid fire risk.
- Do not touch the brake resistor during or after braking to avoid serious burns.

#### **NOTICE**

##### MAINS SHIELD SAFETY OPTION

A mains shield option is available for enclosures with a protection rating of IP21/IP54 (Type 1/Type 12). The mains shield is a cover installed inside the enclosure to protect against the accidental touch of the power terminals, according to BGV A2, VBG 4.



### 2.3.1 ADN-compliant Installation

To prevent spark formation in accordance with the European Agreement concerning International Carriage of Dangerous Goods by Inland Waterways (ADN), take precautions for drives with protection rating of IP00 (Chassis), IP20 (Chassis), IP21 (Type 1), or IP54 (Type 12).

- Do not install a mains switch.
- Ensure that *parameter 14-50 RFI Filter* is set to [1] On.
- Remove all relay plugs marked *RELAY*. See *Illustration 2.1*.
- Check which relay options are installed, if any. The only allowed relay option is VLT® Extended Relay Card MCB 113.

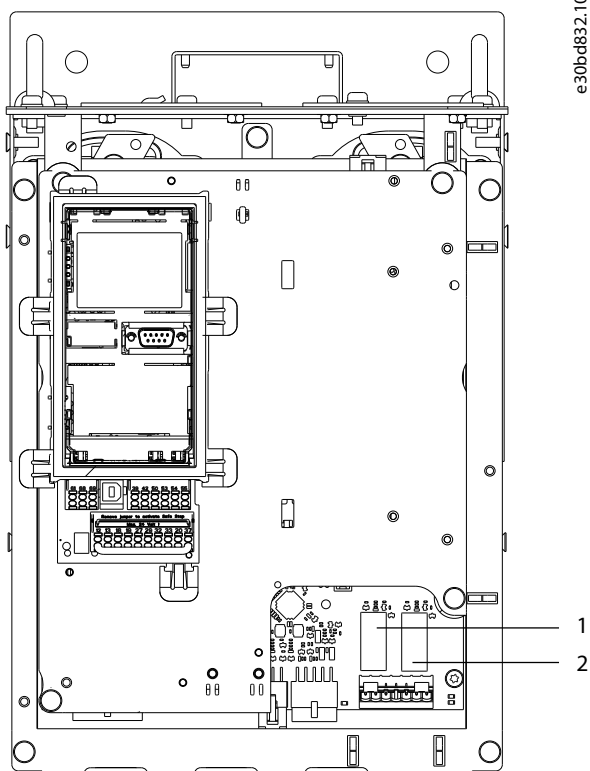

1, 2	Relay plugs
------	-------------

Illustration 2.1 Location of Relay Plugs

## 3 Approvals and Certifications

This section provides a brief description of the various approvals and certifications that are found on Danfoss drives. Not all approvals are found on all drives.

### 3.1 Regulatory/Compliance Approvals

#### **NOTICE**

#### **IMPOSED LIMITATIONS ON THE OUTPUT FREQUENCY**

From software version 3.92 onwards, the output frequency of the drive is limited to 590 Hz due to export control regulations.

#### 3.1.1.1 CE Mark

The CE mark (Communauté Européenne) indicates that the product manufacturer conforms to all applicable EU directives. The EU directives applicable to the design and manufacture of drives are listed in *Table 3.1*.

#### **NOTICE**

The CE mark does not regulate the quality of the product. Technical specifications cannot be deduced from the CE mark.

EU Directive	Version
Low Voltage Directive	2014/35/EU
EMC Directive	2014/30/EU
Machinery Directive <sup>1)</sup>	2014/32/EU
ErP Directive	2009/125/EC
ATEX Directive	2014/34/EU
RoHS Directive	2002/95/EC

**Table 3.1 EU Directives Applicable to Drives**

1) Machinery Directive conformance is only required for drives with an integrated safety function.

#### **NOTICE**

Drives with an integrated safety function, such as Safe Torque Off (STO), must comply with the Machinery Directive.

Declarations of conformity are available on request.

#### **Low Voltage Directive**

Drives must be CE-labeled in accordance with the Low Voltage Directive of January 1, 2014. The Low Voltage Directive applies to all electrical equipment in the 50–1000 V AC and the 75–1500 V DC voltage ranges.

The aim of the directive is to ensure personal safety and avoid property damage when operating electrical equipment that is installed, maintained, and used as intended.

#### **EMC Directive**

The purpose of the EMC (electromagnetic compatibility) Directive is to reduce electromagnetic interference and enhance immunity of electrical equipment and installations. The basic protection requirement of the EMC Directive is that devices that generate electromagnetic interference (EMI), or whose operation can be affected by EMI, must be designed to limit the generation of electromagnetic interference. The devices must have a suitable degree of immunity to EMI when properly installed, maintained, and used as intended.

Electrical equipment devices used alone or as part of a system must bear the CE mark. Systems do not require the CE mark, but must comply with the basic protection requirements of the EMC Directive.

#### **Machinery Directive**

The aim of the Machinery Directive is to ensure personal safety and avoid property damage to mechanical equipment used in its intended application. The Machinery Directive applies to a machine consisting of an aggregate of interconnected components or devices of which at least 1 is capable of mechanical movement.

Drives with an integrated safety function must comply with the Machinery Directive. Drives without a safety function do not fall under the Machinery Directive. If a drive is integrated into a machinery system, Danfoss can provide information on safety aspects relating to the drive.

When drives are used in machines with at least 1 moving part, the machine manufacturer must provide a declaration stating compliance with all relevant statutes and safety measures.

#### 3.1.1.2 ErP Directive

The ErP Directive is the European Ecodesign Directive for energy-related products, including drives. The aim of the directive is to increase energy efficiency and the level of protection of the environment, while increasing the security of the energy supply. Environmental impact of energy-related products includes energy consumption throughout the entire product life cycle.

#### 3.1.1.3 UL Listing

The Underwriters Laboratory (UL) mark certifies the safety of products and their environmental claims based on standardized testing. Drives of voltage T7 (525–690 V) are UL-certified for only 525–600 V.

### 3.1.1.4 CSA/cUL

The CSA/cUL approval is for AC drives of voltage rated at 600 V or lower. The standard ensures that, when the drive is installed according to the provided operating/installation guide, the equipment meets the UL standards for electrical and thermal safety. This mark certifies that the product performs to all required engineering specifications and testing. A certificate of compliance is provided on request.

### 3.1.1.5 EAC

The EurAsian Conformity (EAC) mark indicates that the product conforms to all requirements and technical regulations applicable to the product per the EurAsian Customs Union, which is composed of the member states of the EurAsian Economic Union.

The EAC logo must be both on the product label and on the packaging label. All products used within the EAC area, must be bought at Danfoss inside the EAC area.

### 3.1.1.6 UKrSEPRO

UKrSEPRO certificate ensures quality and safety of both products and services, in addition to manufacturing stability according to Ukrainian regulatory standards. The UkrSepero certificate is a required document to clear customs for any products coming into and out of the territory of Ukraine.

### 3.1.1.7 TÜV

TÜV SÜD is a European safety organization which certifies the functional safety of the drive in accordance to EN/IEC 61800-5-2. The TÜV SÜD both tests products and monitors their production to ensure that companies stay compliant with their regulations.

### 3.1.1.8 RCM

The Regulatory Compliance Mark (RCM) indicates compliance with telecommunications and EMC/radio-communications equipment per the Australian Communications and Media Authorities EMC labeling notice. RCM is now a single compliance mark covering both the A-Tick and the C-Tick compliance marks. RCM compliance is required for placing electrical and electronic devices on the market in Australia and New Zealand.

### 3.1.1.9 Marine

In order for ships and oil/gas platforms to receive a regulatory license and insurance, 1 or more marine certification societies must certify these applications. Up to 12

different marine classification societies have certified Danfoss drive series.

To view or print marine approvals and certificates, go to the download area at <http://drives.danfoss.com/industries/marine-and-offshore/marine-type-approvals/#/>.

### 3.1.2 Export Control Regulations

Drives can be subject to regional and/or national export control regulations.

An ECCN number is used to classify all drives that are subject to export control regulations.

The ECCN number is provided in the documents accompanying the drive.

In case of re-export, it is the responsibility of the exporter to ensure compliance with the relevant export control regulations.

### 3.2 Enclosure Protection Ratings

The VLT® drive series are available in various enclosure protection to accommodate the needs of the application. Enclosure protection ratings are provided based on 2 international standards:

- UL type validates that the enclosures meet NEMA (National Electrical Manufacturers Association) standards. The construction and testing requirements for enclosures are provided in NEMA Standards Publication 250-2003 and UL 50, Eleventh Edition.
- IP (Ingress Protection) ratings outlined by IEC (International Electrotechnical Commission) in the rest of the world.

Standard Danfoss VLT® drive series are available in various enclosure protections to meet the requirements of IP00 (Chassis), IP20 (Protected chassis) or IP21 (UL Type 1), or IP54 (UL Type 12). In this manual, UL Type is written as Type. For example, IP21/Type 1.

#### UL type standard

Type 1 – Enclosures constructed for indoor use to provide a degree of protection to personnel against incidental contact with the enclosed units and to provide a degree of protection against falling dirt.

Type 12 – General-purpose enclosures are intended for use indoors to protect the enclosed units against the following:

- Fibers
- Lint
- Dust and dirt
- Light splashing
- Seepage
- Dripping and external condensation of noncorrosive liquids

There can be no holes through the enclosure and no conduit knockouts or conduit openings, except when used with oil-resistant gaskets to mount oil-tight or dust-tight mechanisms. Doors are also provided with oil-resistant gaskets. In addition, enclosures for combination controllers have hinged doors, which swing horizontally and require a tool to open.

#### IP standard

Table 3.2 provides a cross-reference between the 2 standards. Table 3.3 demonstrates how to read the IP number and then defines the levels of protection. The drives meet the requirements of both.

NEMA and UL	IP
Chassis	IP00
Protected chassis	IP20
Type 1	IP21
Type 12	IP54

Table 3.2 NEMA and IP Number Cross-reference

1 <sup>st</sup> digit	2 <sup>nd</sup> digit	Level of protection
0	–	No protection.
1	–	Protected to 50 mm (2.0 in). No hands would be able to get into the enclosure.
2	–	Protected to 12.5 mm (0.5 in). No fingers would be able to get into the enclosure.
3	–	Protected to 2.5 mm (0.1 in). No tools would be able to get into the enclosure.
4	–	Protected to 1.0 mm (0.04 in). No wires would be able to get into the enclosure.
5	–	Protected against dust – limited entry
6	–	Protected totally against dust
–	0	No protection
–	1	Protected from vertical dripping water
–	2	Protected from dripping water at 15° angle
–	3	Protected from water at 60° angle
–	4	Protected from splashing water
–	5	Protected from water jets
–	6	Protected from strong water jets
–	7	Protected from temporary immersion
–	8	Protected from permanent immersion

Table 3.3 IP Number Breakdown

## 4 Product Overview

### 4.1 VLT® High-power Drives

The Danfoss VLT® drives described in this manual are available as free-standing, wall-mounted, or cabinet-mounted units. Each VLT® drive is configurable, compatible, and efficiency-optimized for all standard motor types, which avoids the restrictions of motor-drive package deals. These drives come in 2 front-end configurations: 6-pulse and 12-pulse.

**4**

#### Benefits of VLT® 6-pulse drives

- Available in various enclosure sizes and protection ratings.
- 98% efficiency reduces operating costs.
- Unique back-channel cooling design reduces the need for more cooling equipment, resulting in lower installation and recurring costs.
- Lower power consumption for control room cooling equipment.
- Reduced ownership costs.
- Consistent user interface across the entire range of Danfoss drives.
- Application-oriented start-up wizards.
- Multi-language user interface.

#### Benefits of VLT® 12-pulse drives

The VLT® 12-pulse is a high efficiency AC drive that provides harmonic reduction without adding capacitive or inductive components, which often require network analysis to avoid potential system resonance problems. The 12-pulse is built with the same modular design as the popular 6-pulse VLT® drive. For more harmonic reduction methods, see the *VLT® Advanced Harmonic Filter AHF 005/AHF 010 Design Guide*.

The 12-pulse drives provide the same benefits as the 6-pulse drives in addition to being:

- Robust and highly stable in all network and operating conditions.
- Ideal for applications where stepping down from medium voltage is required or where isolation from the grid is needed.
- Excellent input transient immunity.

### 4.2 Enclosure Size by Power Rating

kW <sup>1)</sup>	Hp <sup>1)</sup>	Available enclosures	
		6-pulse	12-pulse
315	450	–	F8–F9
355	500	E1–E2	F8–F9
400	550	E1–E2	F8–F9
450	600	E1–E2	F8–F9
500	650	F1–F3	F10–F11
560	750	F1–F3	F10–F11
630	900	F1–F3	F10–F11
710	1000	F1–F3	F10–F11
800	1200	F2–F4	F12–F13
1000	1350	F2–F4	F12–F13

**Table 4.1 Enclosure Power Ratings, 380–480 V**

1) All power ratings are taken at normal overload.  
Output is measured at 400 V (kW) and 460 V (hp).

kW <sup>1)</sup>	Hp <sup>1)</sup>	Available enclosures	
		6-pulse	12-pulse
450	450	E1–E2	F8–F9
500	500	E1–E2	F8–F9
560	600	E1–E2	F8–F9
630	650	E1–E2	F8–F9
710	750	F1–F3	F10–F11
800	950	F1–F3	F10–F11
900	1050	F1–F3	F10–F11
1000	1150	F2–F4	F12–F13
1200	1350	F2–F4	F12–F13
1400	1550	F2–F4	F12–F13

**Table 4.2 Enclosure Power Ratings, 525–690 V**

1) All power ratings are taken at normal overload.  
Output is measured at 690 V (kW) and 575 V (hp).

### 4.3 Overview of Enclosures, 380–480 V

Enclosure size	E1	E2
<b>Power rating<sup>1)</sup></b>		
Output at 400 V (kW)	355–450	355–450
Output at 460 V (hp)	500–600	500–600
<b>Front-end configuration</b>		
6-pulse	S	S
12-pulse	–	–
<b>Protection rating</b>		
IP	IP21/54	IP00
UL type	Type 1/12	Chassis
<b>Hardware options<sup>2)</sup></b>		
Stainless steel back channel	–	O
Mains shielding	O	–
Space heater and thermostat	–	–
Cabinet light with power outlet	–	–
RFI filter (Class A1)	O	O
NAMUR terminals	–	–
Insulation resistance monitor (IRM)	–	–
Residual current monitor (RCM)	–	–
Brake chopper (IGBTs)	O	O
Safe Torque Off	O	O
Regen terminals	O	O
Common motor terminals	–	–
Emergency stop with Pilz safety relay	–	–
Safe Torque Off with Pilz safety relay	–	–
No LCP	–	–
Graphical LCP	S	S
Numerical LCP	O	O
Fuses	O	O
Load share terminals	O	O
Fuses + load share terminals	O	O
Disconnect	O	O
Circuit breakers	–	–
Contactors	–	–
Manual motor starters	–	–
30 A, fuse-protected terminals	–	–
24 V DC supply (SMPS, 5 A)	O	O
External temperature monitoring	–	–
<b>Dimensions</b>		
Height, mm (in)	2000 (78.8)	1547 (60.9)
Width, mm (in)	600 (23.6)	585 (23.0)
Depth, mm (in)	494 (19.4)	498 (19.5)
Weight, kg (lb)	270–313 (595–690)	234–277 (516–611)

**Table 4.3 E1–E2 Drives, 380–480 V**

1) All power ratings are taken at normal overload. Output is measured at 400 V (kW) and 460 V (hp).

2) S = standard, O = optional, and a dash indicates that the option is unavailable.

Enclosure size	F1	F2	F3	F4
<b>Power rating<sup>1)</sup></b>				
Output at 400 V (kW)	500–710	800–1000	500–710	800–1000
Output at 460 V (hp)	650–1000	1200–1350	650–1000	1200–1350
<b>Front-end configuration</b>				
6-pulse	S	S	S	S
12-pulse	–	–	–	–
<b>Protection rating</b>				
IP	IP21/54	IP21/54	IP21/54	IP21/54
UL type	Type 1/12	Type 1/12	Type 1/12	Type 1/12
<b>Hardware options<sup>2)</sup></b>				
Stainless steel back channel	O	O	O	O
Mains shielding	–	–	–	–
Space heater and thermostat	O	O	O	O
Cabinet light with power outlet	O	O	O	O
RFI filter (Class A1)	–	–	–	–
NAMUR terminals	–	–	–	–
Insulation resistance monitor (IRM)	–	–	O	O
Residual current monitor (RCM)	–	–	O	O
Brake chopper (IGBTs)	O	O	O	O
Safe Torque Off	O	O	O	O
Regen terminals	O	O	O	O
Common motor terminals	O	O	O	O
Emergency stop with Pilz safety relay	–	–	O	O
Safe Torque Off with Pilz safety relay	O	O	O	O
No LCP	–	–	–	–
Graphical LCP	S	S	S	S
Numerical LCP	–	–	–	–
Fuses	O	O	O	O
Load share terminals	O	O	O	O
Fuses + load share terminals	O	O	O	O
Disconnect	–	–	O	O
Circuit breakers	–	–	O	O
Contactors	–	–	O	O
Manual motor starters	O	O	O	O
30 A, fuse-protected terminals	O	O	O	O
24 V DC supply (SMPS, 5 A)	O	O	O	O
External temperature monitoring	O	O	O	O
<b>Dimensions</b>				
Height, mm (in)	2204 (86.8)	2204 (86.8)	2204 (86.8)	2204 (86.8)
Width, mm (in)	1400 (55.1)	1800 (70.9)	2000 (78.7)	2400 (94.5)
Depth, mm (in)	606 (23.9)	606 (23.9)	606 (23.9)	606 (23.9)
Weight, kg (lb)	1017 (2242.1)	1260 (2777.9)	1318 (2905.7)	1561 (3441.5)

**Table 4.4 F1–F4 Drives, 380–500 V**

1) All power ratings are taken at normal overload. Output is measured at 400 V (kW) and 460 V (hp).

2) S = standard, O = optional, and a dash indicates that the option is unavailable.



Enclosure size	F8	F9	F10	F11	F12	F13
<b>Power rating<sup>1)</sup></b>						
Output at 400 V (kW)	315–450	315–450	500–710	500–710	800–1000	800–1000
Output at 460 V (hp)	450–600	450–600	650–1000	650–1000	1200–1350	1200–1350
<b>Front-end configuration</b>						
6-pulse	–	–	–	–	–	–
12-pulse	S	S	S	S	S	S
<b>Protection rating</b>						
IP	IP21/54	IP21/54	IP21/54	IP21/54	IP21/54	IP21/54
NEMA	Type 1/12	Type 1/12	Type 1/12	Type 1/12	Type 1/12	Type 1/12
<b>Hardware options<sup>2)</sup></b>						
Stainless steel back channel	–	–	–	–	–	–
Mains shielding	–	–	–	–	–	–
Space heater and thermostat	–	–	O	O	O	O
Cabinet light with power outlet	–	–	O	O	O	O
RFI filter (Class A1)	–	O	–	–	O	O
NAMUR terminals	–	–	–	–	–	–
Insulation resistance monitor (IRM)	–	O	–	–	O	O
Residual current monitor (RCM)	–	O	–	–	O	O
Brake chopper (IGBTs)	O	O	O	O	O	O
Safe Torque Off	O	O	O	O	O	O
Regen terminals	–	–	–	–	–	–
Common motor terminals	–	–	O	O	O	O
Emergency stop with Pilz safety relay	–	–	–	–	–	–
Safe Torque Off with Pilz safety relay	O	O	O	O	O	O
No LCP	–	–	–	–	–	–
Graphical LCP	S	S	S	S	S	S
Numerical LCP	–	–	–	–	–	–
Fuses	O	O	O	O	O	O
Load share terminals	–	–	–	–	–	–
Fuses + load share terminals	–	–	–	–	–	–
Disconnect	–	O	O	O	O	O
Circuit breakers	–	–	–	–	–	–
Contactors	–	–	–	–	–	–
Manual motor starters	–	–	O	O	O	O
30 A, fuse-protected terminals	–	–	O	O	O	O
24 V DC supply (SMPS, 5 A)	O	O	O	O	O	O
External temperature monitoring	–	–	O	O	O	O
<b>Dimensions</b>						
Height, mm (in)	2204 (86.8)	2204 (86.8)	2204 (86.8)	2204 (86.8)	2204 (86.8)	2204 (86.8)
Width, mm (in)	800 (31.5)	1400 (55.2)	1600 (63.0)	2400 (94.5)	2000 (78.7)	2800 (110.2)
Depth, mm (in)	606 (23.9)	606 (23.9)	606 (23.9)	606 (23.9)	606 (23.9)	606 (23.9)
Weight, kg (lb)	447 (985.5)	669 (1474.9)	893 (1968.8)	1116 (2460.4)	1037 (2286.4)	1259 (2775.7)

**Table 4.5 F8–F13 Drives, 380–480 V**

1) All power ratings are taken at normal overload. Output is measured at 400 V (kW) and 460 V (hp).

2) S = standard, O = optional, and a dash indicates that the option is unavailable.

## 4.4 Overview of Enclosures, 525–690 V

Enclosure size	E1	E2
<b>Power rating<sup>1)</sup></b>		
Output at 690 V (kW)	450–630	450–630
Output at 575 V (hp)	450–650	450–650
<b>Front-end configuration</b>		
6-pulse	S	S
12-pulse	–	–
<b>Protection rating</b>		
IP	IP21/54	IP00
UL type	Type 1/12	Chassis
<b>Hardware options<sup>2)</sup></b>		
Stainless steel back channel	–	O
Mains shielding	O	–
Space heater and thermostat	–	–
Cabinet light with power outlet	–	–
RFI filter (Class A1)	O	O
NAMUR terminals	–	–
Insulation resistance monitor (IRM)	–	–
Residual current monitor (RCM)	–	–
Brake chopper (IGBTs)	O	O
Safe Torque Off	S	S
Regen terminals	O	O
Common motor terminals	–	–
Emergency stop with Pilz safety relay	–	–
Safe Torque Off with Pilz safety relay	–	–
No LCP	–	–
Graphical LCP	S	S
Numerical LCP	O	O
Fuses	O	O
Load share terminals	O	O
Fuses + load share terminals	O	O
Disconnect	O	O
Circuit breakers	–	–
Contactors	–	–
Manual motor starters	–	–
30 A, fuse-protected terminals	–	–
24 V DC supply (SMPS, 5 A)	O	O
External temperature monitoring	–	–
<b>Dimensions</b>		
Height, mm (in)	2000 (78.8)	1547 (60.9)
Width, mm (in)	600 (23.6)	585 (23.0)
Depth, mm (in)	494 (19.4)	498 (19.5)
Weight, kg (lb)	263–313 (580–690)	221–277 (487–611)

Table 4.6 E1–E2 Drives, 525–690 V

1) All power ratings are taken at normal overload. Output is measured at 690 V (kW) and 575 V (hp).

2) S = standard, O = optional, and a dash indicates that the option is unavailable.

Enclosure size	F1	F2	F3	F4
<b>Power rating<sup>1)</sup></b>				
Output at 690 V (kW)	710–900	1000–1400	710–900	1000–1400
Output at 575 V (hp)	750–1050	1150–1550	750–1050	1150–1550
<b>Front-end configuration</b>				
6-pulse	S	S	S	S
12-pulse	–	–	–	–
<b>Protection rating</b>				
IP	IP21/54	IP21/54	IP21/54	IP21/54
UL type	Type 1/12	Type 1/12	Type 1/12	Type 1/12
<b>Hardware options<sup>2)</sup></b>				
Stainless steel back channel	O	O	O	O
Mains shielding	–	–	–	–
Space heater and thermostat	O	O	O	O
Cabinet light with power outlet	O	O	O	O
RFI filter (Class A1)	–	–	O	O
NAMUR terminals	–	–	–	–
Insulation resistance monitor (IRM)	–	–	O	O
Residual current monitor (RCM)	–	–	O	O
Brake chopper (IGBTs)	O	O	O	O
Safe Torque Off	O	O	O	O
Regen terminals	O	O	O	O
Common motor terminals	O	O	O	O
Emergency stop with Pilz safety relay	–	–	O	O
Safe Torque Off with Pilz safety relay	O	O	O	O
No LCP	–	–	–	–
Graphical LCP	S	S	S	S
Numerical LCP	–	–	–	–
Fuses	O	O	O	O
Load share terminals	O	O	O	O
Fuses + load share terminals	O	O	O	O
Disconnect	–	–	O	O
Circuit breakers	–	–	O	O
Contactors	–	–	O	O
Manual motor starters	O	O	O	O
30 A, fuse-protected terminals	O	O	O	O
24 V DC supply (SMPS, 5 A)	O	O	O	O
External temperature monitoring	O	O	O	O
<b>Dimensions</b>				
Height, mm (in)	2204 (86.8)	2204 (86.8)	2204 (86.8)	2204 (86.8)
Width, mm (in)	1400 (55.1)	1800 (70.9)	2000 (78.7)	2400 (94.5)
Depth, mm (in)	606 (23.9)	606 (23.9)	606 (23.9)	606 (23.9)
Weight, kg (lb)	1017 (2242.1)	1260 (2777.9)	1318 (2905.7)	1561 (3441.5)

**Table 4.7 F1–F4 Drives, 525–690 V**

1) All power ratings are taken at normal overload. Output is measured at 690 V (kW) and 575 V (hp).

2) S = standard, O = optional, and a dash indicates that the option is unavailable.

Enclosure size	F8	F9	F10	F11	F12	F13
<b>Power rating<sup>1)</sup></b>						
Output at 690 V (kW)	450–630	450–630	710–900	710–900	1000–1400	1000–1400
Output at 575 V (hp)	450–650	450–650	750–1050	750–1050	1150–1550	1150–1550
<b>Front-end configuration</b>						
6-pulse	–	–	–	–	–	–
12-pulse	S	S	S	S	S	S
<b>Protection rating</b>						
IP	IP21/54	IP21/54	IP21/54	IP21/54	IP21/54	IP21/54
NEMA	Type 1/12	Type 1/12	Type 1/12	Type 1/12	Type 1/12	Type 1/12
<b>Hardware options<sup>2)</sup></b>						
Stainless steel back channel	–	–	–	–	–	–
Mains shielding	–	–	–	–	–	–
Space heater and thermostat	–	–	O	O	O	O
Cabinet light with power outlet	–	–	O	O	O	O
RFI filter (Class A1)	–	O	–	–	O	O
NAMUR terminals	–	–	–	–	–	–
Insulation resistance monitor (IRM)	–	O	–	–	O	O
Residual current monitor (RCM)	–	O	–	–	O	O
Brake chopper (IGBTs)	O	O	O	O	O	O
Safe Torque Off	O	O	O	O	O	O
Regen terminals	–	–	–	–	–	–
Common motor terminals	–	–	O	O	O	O
Emergency stop with Pilz safety relay	–	–	–	–	–	–
Safe Torque Off with Pilz safety relay	O	O	O	O	O	O
No LCP	–	–	–	–	–	–
Graphical LCP	S	S	S	S	S	S
Numerical LCP	–	–	–	–	–	–
Fuses	O	O	O	O	O	O
Load share terminals	–	–	–	–	–	–
Fuses + load share terminals	–	–	–	–	–	–
Disconnect	–	O	O	O	O	O
Circuit breakers	–	–	–	–	–	–
Contactors	–	–	–	–	–	–
Manual motor starters	–	–	O	O	O	O
30 A, fuse-protected terminals	–	–	O	O	O	O
24 V DC supply (SMPS, 5 A)	O	O	O	O	O	O
External temperature monitoring	–	–	O	O	O	O
<b>Dimensions</b>						
Height, mm (in)	2204 (86.8)	2204 (86.8)	2204 (86.8)	2204 (86.8)	2204 (86.8)	2204 (86.8)
Width, mm (in)	800 (31.5)	1400 (55.1)	1600 (63.0)	2400 (94.5)	2000 (78.7)	2800 (110.2)
Depth, mm (in)	606 (23.9)	606 (23.9)	606 (23.9)	606 (23.9)	606 (23.9)	606 (23.9)
Weight, kg (lb)	447 (985.5)	669 (1474.9)	893 (1968.8)	1116 (2460.4)	1037 (2286.4)	1259 (2775.7)

**Table 4.8 F8–F13 Drives, 525–690 V**

1) All power ratings are taken at normal overload. Output is measured at 690 V (kW) and 575 V (hp).

2) S = standard, O = optional, and a dash indicates that the option is unavailable.

## 4.5 Kit Availability

Kit description <sup>1)</sup>	E1	E2	F1	F2	F3	F4	F8	F9	F10	F11	F12	F13
USB in door	O	-	O	O	O	O	O	O	O	O	O	O
LCP, numerical	O	O	O	O	O	O	O	O	O	O	O	O
LCP, graphical <sup>2)</sup>	O	O	O	O	O	O	O	O	O	O	O	O
LCP cable, 3 m (9 ft)	O	O	O	O	O	O	O	O	O	O	O	O
Mounting kit for numerical LCP (LCP, fasteners, gasket, and cable)	O	O	O	O	O	O	O	O	O	O	O	O
Mounting kit for graphical LCP (LCP, fasteners, gasket, and cable)	O	O	O	O	O	O	O	O	O	O	O	O
Mounting kit for all LCPs (fasteners, gasket, and cable)	O	O	O	O	O	O	O	O	O	O	O	O
Top entry for motor cables	-	-	O	O	O	O	O	O	O	O	O	O
Top entry for mains cables	-	-	O	O	O	O	O	O	O	O	O	O
Top entry for mains cables with disconnect	-	-	-	-	O	O	-	-	-	-	-	-
Top entry for fieldbus cables	-	O	-	-	-	-	-	-	-	-	-	-
Common motor terminals	-	-	O	O	O	O	-	-	-	-	-	-
NEMA 3R enclosure	-	O	-	-	-	-	-	-	-	-	-	-
Pedestal	O	O	-	-	-	-	-	-	-	-	-	-
Input options plate	O	O	-	-	-	-	-	-	-	-	-	-
IP20 conversion	-	O	-	-	-	-	-	-	-	-	-	-
Out top (only) cooling	-	O	-	-	-	-	-	-	-	-	-	-
Back-channel cooling (in-back/out-back)	O	O	O	O	O	O	O	O	O	O	O	O
Back-channel cooling (in-bottom/out-top)	-	O	-	-	-	-	-	-	-	-	-	-

**Table 4.9 Available Kits for Enclosures E1–E2, F1–F4, and F8–F13**

1) S = standard, O = optional, and a dash indicates that the kit is unavailable for that enclosure. For kit descriptions and part numbers, see chapter 13.2 Ordering Numbers for Options/Kits.

2) The graphical LCP comes standard with enclosures E1–E2, F1–F4, and F8–F13. If more than 1 graphical LCP is required, the kit is available for purchase.

## 5 Product Features

### 5.1 Automated Operational Features

Automated operational features are active when the drive is operating. Most of them require no programming or set-up. The drive has a range of built-in protection functions to protect itself and the motor when it runs.

For details of any set-up required, in particular motor parameters, refer to the *programming guide*.

#### 5.1.1 Short-circuit Protection

##### Motor (phase-to-phase)

The drive is protected against short circuits on the motor side by current measurement in each of the 3 motor phases. A short circuit between 2 output phases causes an overcurrent in the inverter. The inverter is turned off when the short circuit current exceeds the permitted value (*Alarm 16, Trip Lock*).

##### Mains side

A drive that works correctly limits the current it can draw from the supply. Still, it is recommended to use fuses and/or circuit breakers on the supply side as protection if there is component break-down inside the drive (first fault). Mains side fuses are mandatory for UL compliance.

#### **NOTICE**

**To ensure compliance with IEC 60364 for CE or NEC 2009 for UL, it is mandatory to use fuses and/or circuit breakers.**

##### Brake resistor

The drive is protected from a short circuit in the brake resistor.

##### Load sharing

To protect the DC bus against short circuits and the drives from overload, install DC fuses in series with the load sharing terminals of all connected units.

#### 5.1.2 Overvoltage Protection

##### Motor-generated overvoltage

The voltage in the DC link is increased when the motor acts as a generator. This situation occurs in following cases:

- The load rotates the motor at constant output frequency from the drive, that is, the load generates energy.
- During deceleration (ramp-down) if the inertia moment is high, the friction is low, and the ramp-down time is too short for the energy to be dissipated as a loss throughout the drive system.

- Incorrect slip compensation setting causing higher DC-link voltage.
- Back EMF from PM motor operation. If coasted at high RPM, the PM motor back EMF can potentially exceed the maximum voltage tolerance of the drive and cause damage. To help prevent this situation, the value of *parameter 4-19 Max Output Frequency* is automatically limited based on an internal calculation based on the value of *parameter 1-40 Back EMF at 1000 RPM*, *parameter 1-25 Motor Nominal Speed*, and *parameter 1-39 Motor Poles*.

#### **NOTICE**

**To avoid motor overspeeds (for example, due to excessive windmilling effects), equip the drive with a brake resistor.**

The overvoltage can be handled either using a brake function (*parameter 2-10 Brake Function*) and/or using overvoltage control (*parameter 2-17 Over-voltage Control*).

##### Brake functions

Connect a brake resistor for dissipation of surplus brake energy. Connecting a brake resistor allows a higher DC-link voltage during braking.

AC brake is an alternative to improving braking without using a brake resistor. This function controls an over-magnetization of the motor when the motor is acting as a generator. Increasing the electrical losses in the motor allows the OVC function to increase the braking torque without exceeding the overvoltage limit.

#### **NOTICE**

**AC brake is not as effective as dynamic braking with a resistor.**

##### Overvoltage control (OVC)

By automatically extending the ramp-down time, OVC reduces the risk of the drive tripping due to an overvoltage on the DC-link.

#### **NOTICE**

**OVC can be activated for a PM motor with all control core, PM VVC<sup>+</sup>, Flux OL, and Flux CL for PM Motors.**

#### 5.1.3 Missing Motor Phase Detection

The missing motor phase function (*parameter 4-58 Missing Motor Phase Function*) is enabled by default to avoid motor damage if a motor phase is missing. The default setting is 1000 ms, but it can be adjusted for faster detection.

### 5.1.4 Supply Voltage Imbalance Detection

Operation under severe supply voltage imbalance reduces the lifetime of the motor and drive. If the motor is operated continuously near nominal load, conditions are considered severe. The default setting trips the drive if there is supply voltage imbalance (*parameter 14-12 Function at Mains Imbalance*).

### 5.1.5 Switching on the Output

Adding a switch to the output between the motor and the drive is allowed, however fault messages can appear. Danfoss does not recommend using this feature for 525–690 V drives connected to an IT mains network.

### 5.1.6 Overload Protection

#### Torque limit

The torque limit feature protects the motor against overload, independent of the speed. Torque limit is controlled in *parameter 4-16 Torque Limit Motor Mode* and *parameter 4-17 Torque Limit Generator Mode*. The time before the torque limit warning trips is controlled in *parameter 14-25 Trip Delay at Torque Limit*.

#### Current limit

The current limit is controlled in *parameter 4-18 Current Limit*, and the time before the drive trips is controlled in *parameter 14-24 Trip Delay at Current Limit*.

#### Speed limit

Minimum speed limit: *Parameter 4-11 Motor Speed Low Limit [RPM]* or *parameter 4-12 Motor Speed Low Limit [Hz]* limit the minimum operating speed range of the drive. Maximum speed limit: *Parameter 4-13 Motor Speed High Limit [RPM]* or *parameter 4-19 Max Output Frequency* limit the maximum output speed the drive can provide.

#### Electronic thermal relay (ETR)

ETR is an electronic feature that simulates a bimetal relay based on internal measurements. The characteristic is shown in *Illustration 5.1*.

#### Voltage limit

The inverter turns off to protect the transistors and the DC link capacitors when a certain hard-coded voltage level is reached.

#### Overtemperature

The drive has built-in temperature sensors and reacts immediately to critical values via hard-coded limits.

### 5.1.7 Locked Rotor Protection

There can be situations when the rotor is locked due to excessive load or other factors. The locked rotor cannot produce enough cooling, which in turn can overheat the motor winding. The drive is able to detect the locked rotor

situation with open-loop PM flux control and PM VVC<sup>+</sup> control (*parameter 30-22 Locked Rotor Detection*).

### 5.1.8 Automatic Derating

The drive constantly checks for the following critical levels:

- High temperature on the control card or heat sink.
- High motor load.
- High DC-link voltage.
- Low motor speed.

As a response to a critical level, the drive adjusts the switching frequency. For high internal temperatures and low motor speed, the drives can also force the PWM pattern to SFAVM.

#### **NOTICE**

The automatic derating is different when *parameter 14-55 Output Filter* is set to [2] *Sine-Wave Filter Fixed*.

### 5.1.9 Automatic Energy Optimization

Automatic energy optimization (AEO) directs the drive to monitor the load on the motor continuously and adjust the output voltage to maximize efficiency. Under light load, the voltage is reduced and the motor current is minimized. The motor benefits from:

- Increased efficiency.
- Reduced heating.
- Quieter operation.

There is no need to select a V/Hz curve because the drive automatically adjusts motor voltage.

### 5.1.10 Automatic Switching Frequency Modulation

The drive generates short electrical pulses to form an AC wave pattern. The switching frequency is the rate of these pulses. A low switching frequency (slow pulsing rate) causes audible noise in the motor, making a higher switching frequency preferable. A high switching frequency, however, generates heat in the drive that can limit the amount of current available to the motor.

Automatic switching frequency modulation regulates these conditions automatically to provide the highest switching frequency without overheating the drive. By providing a regulated high switching frequency, it quiets motor operating noise at slow speeds, when audible noise control is critical, and produces full output power to the motor when required.

### 5.1.11 Automatic Derating for High Switching Frequency

The drive is designed for continuous, full-load operation at switching frequencies between 1.5–2 kHz for 380–480 V, and 1–1.5 kHz for 525–690 V. The frequency range depends on power size and voltage rating. A switching frequency exceeding the maximum allowed range generates increased heat in the drive and requires the output current to be derated.

An automatic feature of the drive is load-dependent switching frequency control. This feature allows the motor to benefit from as high a switching frequency as the load allows.

### 5.1.12 Power Fluctuation Performance

The drive withstands mains fluctuations such as:

- Transients.
- Momentary drop-outs.
- Short voltage drops.
- Surges.

The drive automatically compensates for input voltages  $\pm 10\%$  from the nominal to provide full rated motor voltage and torque. With auto restart selected, the drive automatically powers up after a voltage trip. With flying start, the drive synchronizes to motor rotation before start.

### 5.1.13 Resonance Damping

Resonance damping eliminates the high-frequency motor resonance noise. Automatic or manually selected frequency damping is available.

### 5.1.14 Temperature-controlled Fans

Sensors in the drive regulate the operation of the internal cooling fans. Often, the cooling fans do not run during low load operation, or when in sleep mode or standby. These sensors reduce noise, increase efficiency, and extend the operating life of the fan.

### 5.1.15 EMC Compliance

Electromagnetic interference (EMI) and radio frequency interference (RFI) are disturbances that can affect an electrical circuit due to electromagnetic induction or radiation from an external source. The drive is designed to comply with the EMC product standard for drives IEC 61800-3 and the European standard EN 55011. Motor cables must be shielded and properly terminated to comply with the emission levels in EN 55011. For more

information regarding EMC performance, see *chapter 10.15.1 EMC Test Results*.

### 5.1.16 Galvanic Isolation of Control Terminals

All control terminals and output relay terminals are galvanically isolated from mains power, which completely protects the controller circuitry from the input current. The output relay terminals require their own grounding. This isolation meets the stringent protective extra-low voltage (PELV) requirements for isolation.

**The components that make up the galvanic isolation are:**

- Supply, including signal isolation.
- Gatedrive for the IGBTs, trigger transformers, and optocouplers.
- The output current Hall effect transducers.

## 5.2 Custom Application Features

Custom application functions are the most common features programmed in the drive for enhanced system performance. They require minimum programming or set-up. See the *programming guide* for instructions on activating these functions.

### 5.2.1 Automatic Motor Adaptation

Automatic motor adaptation (AMA) is an automated test procedure used to measure the electrical characteristics of the motor. AMA provides an accurate electronic model of the motor, allowing the drive to calculate optimal performance and efficiency. Running the AMA procedure also maximizes the automatic energy optimization feature of the drive. AMA is performed without the motor rotating and without uncoupling the load from the motor.

### 5.2.2 Built-in PID Controller

The built-in proportional, integral, derivative (PID) controller eliminates the need for auxiliary control devices. The PID controller maintains constant control of closed-loop systems where regulated pressure, flow, temperature, or other system requirements must be maintained.

The drive can use 2 feedback signals from 2 different devices, allowing the system to be regulated with different feedback requirements. The drive makes control decisions by comparing the 2 signals to optimize system performance.



### 5.2.3 Motor Thermal Protection

Motor thermal protection can be provided via:

- Direct temperature sensing using a
  - PTC- or KTY sensor in the motor windings and connected on a standard AI or DI.
  - PT100 or PT1000 in the motor windings and motor bearings, connected on VLT® Sensor Input Card MCB 114.
  - PTC Thermistor input on VLT® PTC Thermistor Card MCB 112 (ATEX approved).
- Mechanical thermal switch (Klixon type) on a DI.
- Built-in electronic thermal relay (ETR).

ETR calculates motor temperature by measuring current, frequency, and operating time. The drive shows the thermal load on the motor in percentage and can issue a warning at a programmable overload setpoint. Programmable options at the overload allow the drive to stop the motor, reduce output, or ignore the condition. Even at low speeds, the drive meets I2t Class 20 electronic motor overload standards.

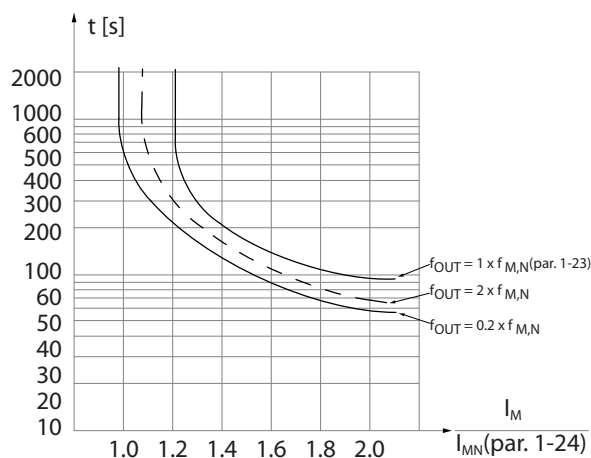

Illustration 5.1 ETR Characteristics

The X-axis shows the ratio between  $I_{\text{motor}}$  and  $I_{\text{motor}}$  nominal. The Y-axis shows the time in seconds before the ETR cuts off and trips the drive. The curves show the characteristic nominal speed, at twice the nominal speed and at 0.2 x the nominal speed.

At lower speed, the ETR cuts off at lower heat due to less cooling of the motor. In that way, the motor is protected from being overheated even at low speed. The ETR feature calculates the motor temperature based on actual current and speed. The calculated temperature is visible as a readout parameter in *parameter 16-18 Motor Thermal*. A special version of the ETR is also available for EX-e motors in ATEX areas. This function makes it possible to

enter a specific curve to protect the Ex-e motor. See the *programming guide* for set-up instructions.

### 5.2.4 Motor Thermal Protection for Ex-e Motors

The drive is equipped with an ATEX ETR thermal monitoring function for operation of Ex-e motors according to EN-60079-7. When combined with an ATEX approved PTC monitoring device such as the VLT® PTC Thermistor Card MCB 112 or an external device, the installation does not require an individual approval from an approved organization.

The ATEX ETR thermal monitoring function enables use of an Ex-e motor instead of a more expensive, larger, and heavier Ex-d motor. The function ensures that the drive limits motor current to prevent overheating.

#### Requirements related to the Ex-e motor

- Ensure that the Ex-e motor is approved for operation in hazardous zones (ATEX zone 1/21, ATEX zone 2/22) with drives. The motor must be certified for the specific hazardous zone.
- Install the Ex-e motor in zone 1/21 or 2/22 of the hazardous zone, according to motor approval.

#### NOTICE

Install the drive outside the hazardous zone.

- Ensure that the Ex-e motor is equipped with an ATEX-approved motor overload protection device. This device monitors the temperature in the motor windings. If there is a critical temperature level or a malfunction, the device switches off the motor.
  - The VLT® PTC Thermistor MCB 112 option provides ATEX-approved monitoring of motor temperature. It is a prerequisite that the drive is equipped with 3–6 PTC thermistors in series according to DIN 44081 or 44082.
  - Alternatively, an external ATEX-approved PTC protection device can be used.
- Sine-wave filter is required when the following apply:
  - Long cables (voltage peaks) or increased mains voltage produce voltages exceeding the maximum allowable voltage at motor terminals.
  - Minimum switching frequency of the drive does not meet the requirement stated by the motor manufacturer. The minimum switching frequency of the

drive is shown as the default value in parameter 14-01 Switching Frequency.

**Compatibility of motor and drive**

For motors certified according to EN-60079-7, a data list including limits and rules is supplied by the motor manufacturer as a datasheet, or on the motor nameplate. During planning, installation, commissioning, operation, and service, follow the limits and rules supplied by the manufacturer for:

- Minimum switching frequency.
- Maximum current.
- Minimum motor frequency.
- Maximum motor frequency.

Illustration 5.2 shows where the requirements are indicated on the motor nameplate.

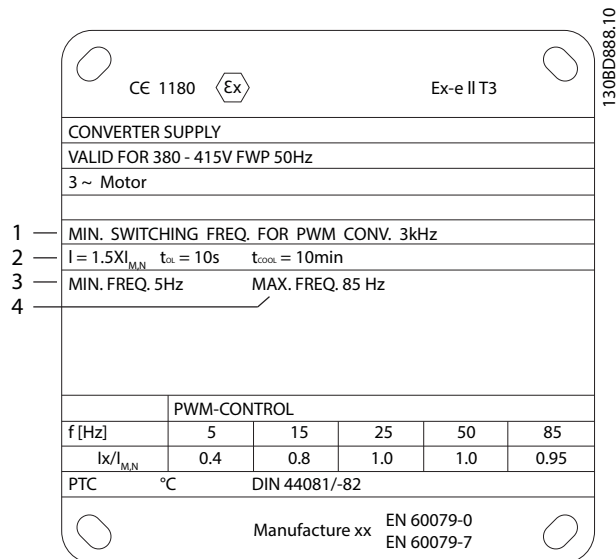

1	Minimum switching frequency
2	Maximum current
3	Minimum motor frequency
4	Maximum motor frequency

Illustration 5.2 Motor Nameplate showing Drive Requirements

When matching drive and motor, Danfoss specifies the following extra requirements to ensure adequate motor thermal protection:

- Do not exceed the maximum allowed ratio between drive size and motor size. The typical value is  $I_{VLT, n} \leq 2xI_{m, n}$
- Consider all voltage drops from drive to motor. If the motor runs with lower voltage than listed in the U/f characteristics, current can increase, triggering an alarm.

For further information, see the application example in chapter 12 Application Examples.

**5.2.5 Mains Drop-out**

During a mains drop-out, the drive keeps running until the DC-link voltage drops below the minimum stop level. The minimum stop level is typically 15% below the lowest rated supply voltage. The mains voltage before the drop-out and the motor load determines how long it takes for the drive to coast.

The drive can be configured (parameter 14-10 Mains Failure) to different types of behavior during mains drop-out:

- Trip lock once the DC link is exhausted.
- Coast with flying start whenever mains return (parameter 1-73 Flying Start).
- Kinetic back-up.
- Controlled ramp down.

**Flying start**

This selection makes it possible to catch a motor that is spinning freely due to a mains drop-out. This option is relevant for centrifuges and fans.

**Kinetic back-up**

This selection ensures that the drive runs as long as there is energy in the system. For short mains drop-out, the operation is restored after mains return, without bringing the application to a stop or losing control at any time. Several variants of kinetic back-up can be selected.

Configure the behavior of the drive at mains drop-out, in parameter 14-10 Mains Failure and parameter 1-73 Flying Start.

**5.2.6 Automatic Restart**

The drive can be programmed to restart the motor automatically after a minor trip, such as momentary power loss or fluctuation. This feature eliminates the need for manual resetting, and enhances automated operation for remotely controlled systems. The number of restart attempts and the duration between attempts can be limited.

**5.2.7 Full Torque at Reduced Speed**

The drive follows a variable V/Hz curve to provide full motor torque even at reduced speeds. Full output torque can coincide with the maximum designed operating speed of the motor. This drive differs from variable torque drives and constant torque drives. Variable torque drives provide reduced motor torque at low speed. Constant torque drives provide excess voltage, heat, and motor noise at less than full speed.

### 5.2.8 Frequency Bypass

In some applications, the system can have operational speeds that create a mechanical resonance. This mechanical resonance can generate excessive noise and possibly damage mechanical components in the system. The drive has 4 programmable bypass-frequency bandwidths. The bandwidths allow the motor to step over speeds that induce system resonance.

### 5.2.9 Motor Preheat

To preheat a motor in a cold or damp environment, a small amount of DC current can be trickled continuously into the motor to protect it from condensation and cold starts. This function can eliminate the need for a space heater.

### 5.2.10 Programmable Set-ups

The drive has 4 set-ups that can be independently programmed. Using multi-setup, it is possible to switch between independently programmed functions activated by digital inputs or a serial command. Independent set-ups are used, for example, to change references, or for day/night or summer/winter operation, or to control multiple motors. The LCP shows the active set-up.

Set-up data can be copied from drive to drive by downloading the information from the removable LCP.

### 5.2.11 Smart Logic Control (SLC)

Smart logic control (SLC) is a sequence of user-defined actions (see *parameter 13-52 SL Controller Action [x]*) executed by the SLC when the associated user-defined event (see *parameter 13-51 SL Controller Event [x]*) is evaluated as TRUE by the SLC.

The condition for an event can be a particular status, or that the output from a logic rule or a comparator operand becomes TRUE. The condition leads to an associated action as shown in *Illustration 5.3*.

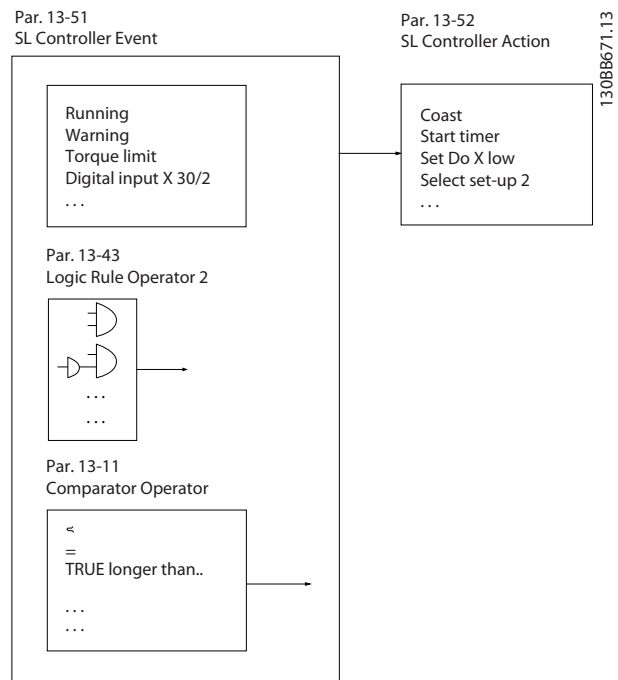

Illustration 5.3 SLC Event and Action

Events and actions are each numbered and linked in pairs (states), which means that when event [0] is fulfilled (attains the value TRUE), action [0] is executed. After the 1<sup>st</sup> action is executed, the conditions of the next event are evaluated. If this event is evaluated as true, then the corresponding action is executed. Only 1 event is evaluated at any time. If an event is evaluated as false, nothing happens in the SLC during the current scan interval and no other events are evaluated. When the SLC starts, it only evaluates event [0] during each scan interval. Only when event [0] is evaluated as true, the SLC executes action [0] and starts evaluating the next event. It is possible to program 1–20 events and actions. When the last event/action has been executed, the sequence starts over again from event [0]/action [0]. *Illustration 5.4* shows an example with 4 event/actions:

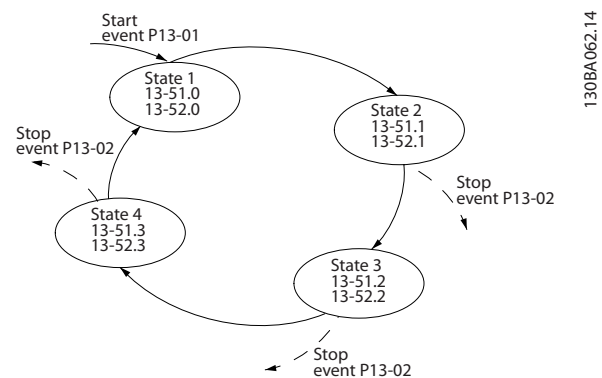

Illustration 5.4 Order of Execution when 4 Events/Actions are Programmed

**Comparators**

Comparators are used for comparing continuous variables (output frequency, output current, analog input, and so on) to fixed preset values.

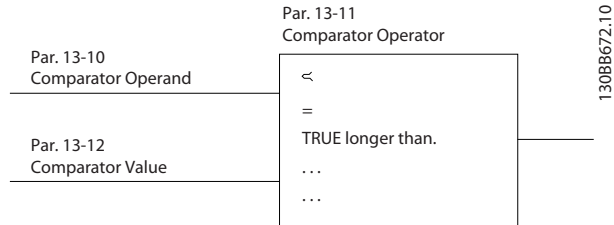

Illustration 5.5 Comparators

**Logic rules**

Combine up to 3 boolean inputs (TRUE/FALSE inputs) from timers, comparators, digital inputs, status bits, and events using the logical operators AND, OR, and NOT.

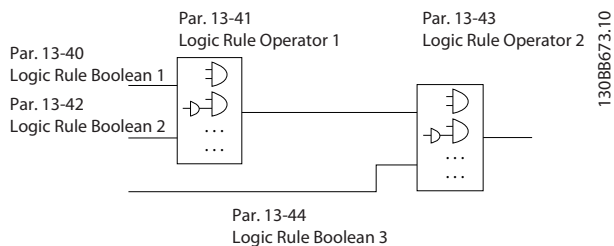

Illustration 5.6 Logic Rules

**5.2.12 Safe Torque Off**

The Safe Torque Off (STO) function is used to stop the drive in emergency stop situations. The drive can use the STO function with asynchronous, synchronous, and permanent magnet motors.

For more information about Safe Torque Off, including installation and commissioning, refer to the *Safe Torque Off Operating Guide*.

**Liability conditions**

The customer is responsible for ensuring that personnel know how to install and operate the safe torque off function by:

- Reading and understanding the safety regulations concerning health, safety, and accident prevention.
- Understanding the generic and safety guidelines provided in the *Safe Torque Off Operating Guide*.
- Having a good knowledge of the generic and safety standards for the specific application.

**5.3 Specific VLT® HVAC Drive Features**

A drive takes advantage of the fact that centrifugal fans and pumps follow the laws of proportionality for such applications. For further information, see *chapter 5.3.1 Using a Drive for Energy Savings*.

**5.3.1 Using a Drive for Energy Savings**

The clear advantage of using a drive for controlling the speed of fans and pumps lies in the electricity savings. When comparing with alternative control systems and technologies, a drive is the optimum energy control system for controlling fan and pump systems.

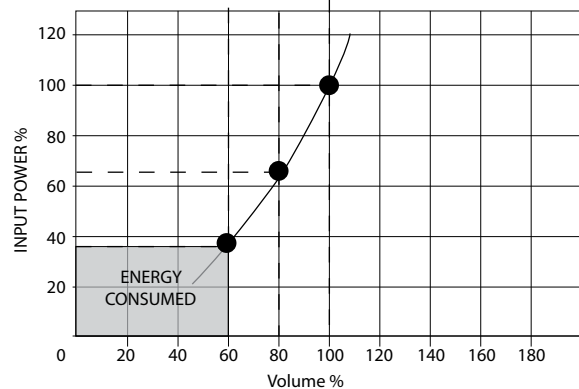
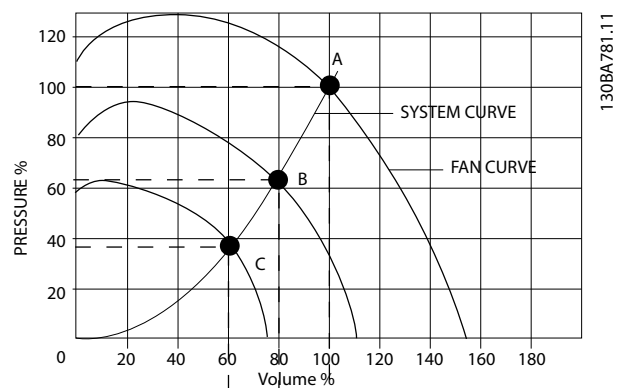

Illustration 5.7 Energy Saved with Reduced Fan Capacity

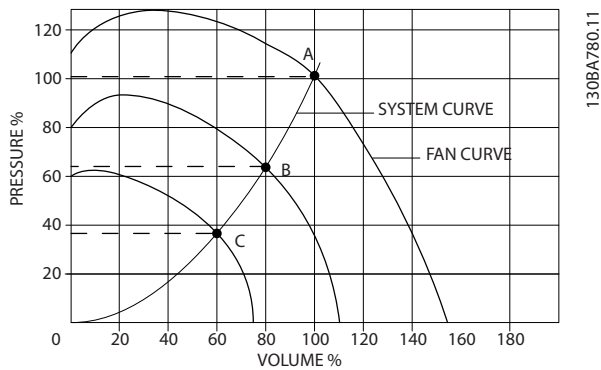

Illustration 5.8 Fan Curves for Reduced Fan Volumes.

**Example of energy savings**

Illustration 5.9 describes the dependence of flow, pressure, and power consumption on RPM. As seen in Illustration 5.9, the flow is controlled by changing the RPM. Reducing the speed only 20% from the rated speed also reduces the flow by 20%. The flow is directly proportional to the RPM. The consumption of electricity, however, is reduced by 50%.

If the system only runs at 100% flow a few days per year, while the average is below 80% of the rated flow, the amount of energy saved is even more than 50%.

$$\text{Flow: } \frac{Q_1}{Q_2} = \frac{n_1}{n_2}$$

$$\text{Pressure: } \frac{H_1}{H_2} = \left(\frac{n_1}{n_2}\right)^2$$

$$\text{Power: } \frac{P_1}{P_2} = \left(\frac{n_1}{n_2}\right)^3$$

Q	Flow	P	Power
Q <sub>1</sub>	Rated flow	P <sub>1</sub>	Rated power
Q <sub>2</sub>	Reduced flow	P <sub>2</sub>	Reduced power
H	Pressure	n	Speed control
H <sub>1</sub>	Rated pressure	n <sub>1</sub>	Rated speed
H <sub>2</sub>	Reduced pressure	n <sub>2</sub>	Reduced speed

Table 5.1 Laws of Proportionality Definitions

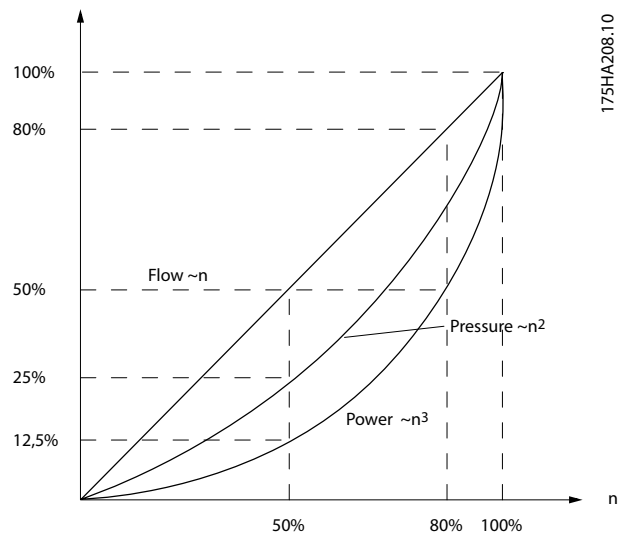

Illustration 5.9 Laws of Proportionality

**Comparison of energy savings**

The Danfoss drive solution offers major savings compared with traditional energy saving solutions. The drive regulates fan speed according to thermal load on the system and functions as a building management system (BMS).

The graph (Illustration 5.10) shows typical energy savings obtainable with 3 well-known solutions when fan volume is reduced to 60%. As the graph shows, more than 50% energy savings can be achieved in typical applications.

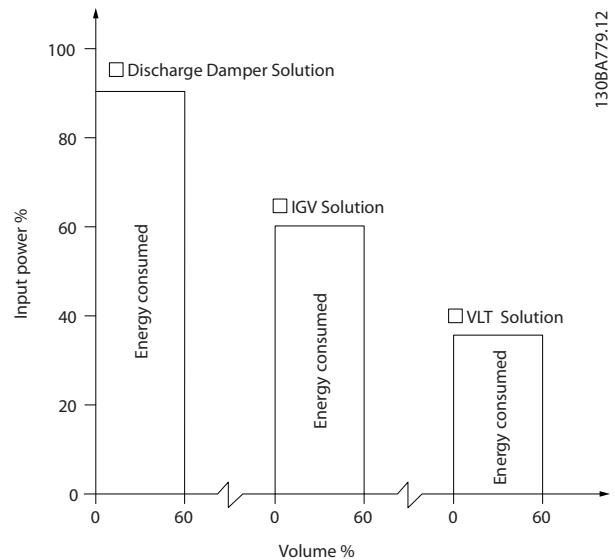

Illustration 5.10 3 Common Energy Saving Systems

Discharge dampers reduce power consumption. Inlet guide vanes offer a 40% reduction but are expensive to install. The Danfoss drive solution reduces energy consumption by more than 50% and is easy to install.

**Example with varying flow over 1 year**

Illustration 5.11 is based on pump characteristics obtained from a pump datasheet. The result obtained shows energy savings more than 50% at the given flow distribution over a year. The payback period depends on the price per kWh and the price of the drive. In this example, it is less than a year when compared with valves and constant speed.

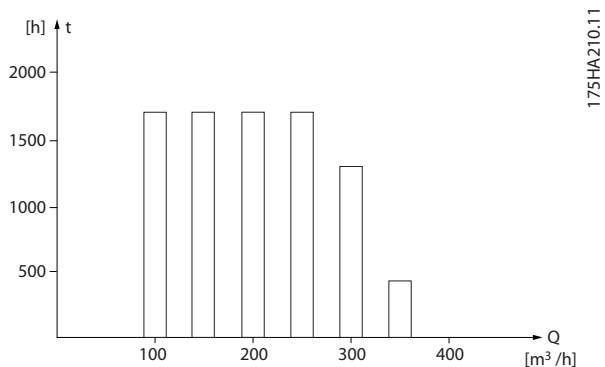

Illustration 5.11 Flow Distribution Over 1 Year

m³/h	Distribution		Valve regulation		Drive control	
	%	Hours	Power	Consumption	Power	Consumption
			A <sub>1</sub> -B <sub>1</sub>	kWh	A <sub>1</sub> -C <sub>1</sub>	kWh
350	5	438	42.5	18615	42.5	18615
300	15	1314	38.5	50589	29.0	38106
250	20	1752	35.0	61320	18.5	32412
200	20	1752	31.5	55188	11.5	20148
150	20	1752	28.0	49056	6.5	11388
100	20	1752	23.0	40296	3.5	6132
Σ	100	8760	-	275064	-	26801

Table 5.2 Energy Savings Calculation

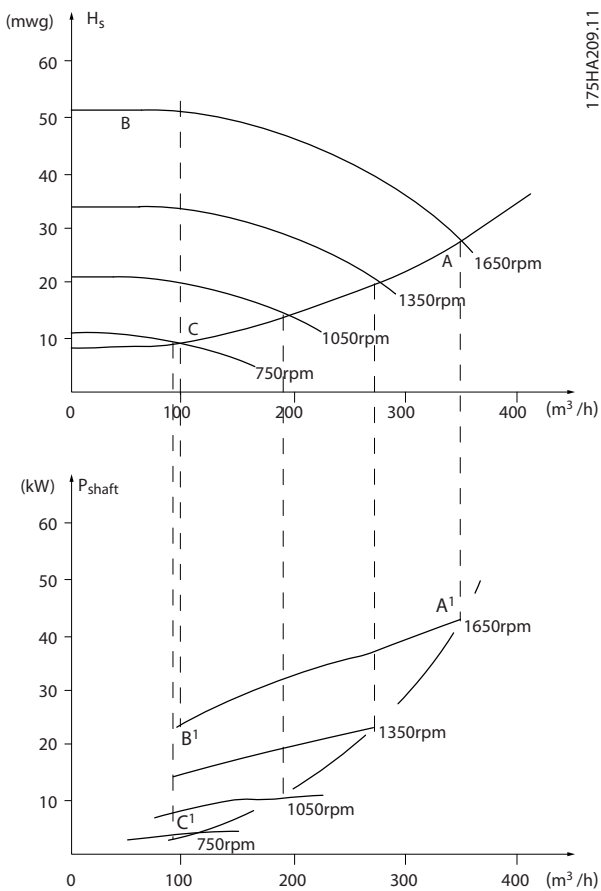
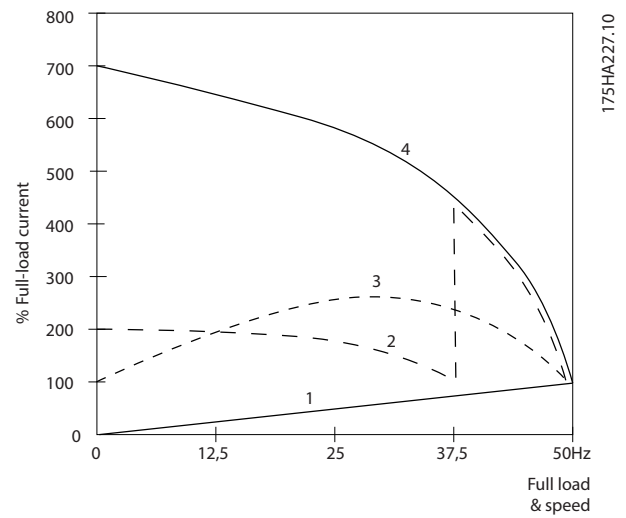

Illustration 5.12 Energy Savings in a Pump Application



1	VLT® HVAC Drive FC 102
2	Star/delta starter
3	Soft starter
4	Start directly on mains

Illustration 5.13 Current Consumption with a Drive

### 5.3.2 Using a Drive for Better Control

If a drive is used for controlling the flow or pressure of a system, improved control is obtained. A drive can vary the speed of the fan or pump, obtaining variable control of flow and pressure utilizing the built-in PID control. Furthermore, a drive can quickly adapt the speed of the fan or pump to new flow or pressure conditions in the system.

#### Cos $\phi$ compensation

Typically, the VLT® HVAC Drive has a  $\cos \phi$  of 1 and provides power factor correction for the  $\cos \phi$  of the motor, which means there is no need to make allowance for the  $\cos \phi$  of the motor when sizing the power factor correction unit.

#### Star/delta starter or soft starter not required

When larger motors are started, it is necessary in many countries to use equipment that limits the start-up current. In more traditional systems, a star/delta starter or soft starter is widely used. Such motor starters are not required if a drive is used. As illustrated in *Illustration 5.13*, a drive does not consume more than rated current.

### 5.3.3 Using a Drive to Save Money

The drive eliminates the need for some equipment that would normally be used. The 2 systems shown in *Illustration 5.14* and *Illustration 5.15* can be established at roughly the same price.

#### Cost without a drive

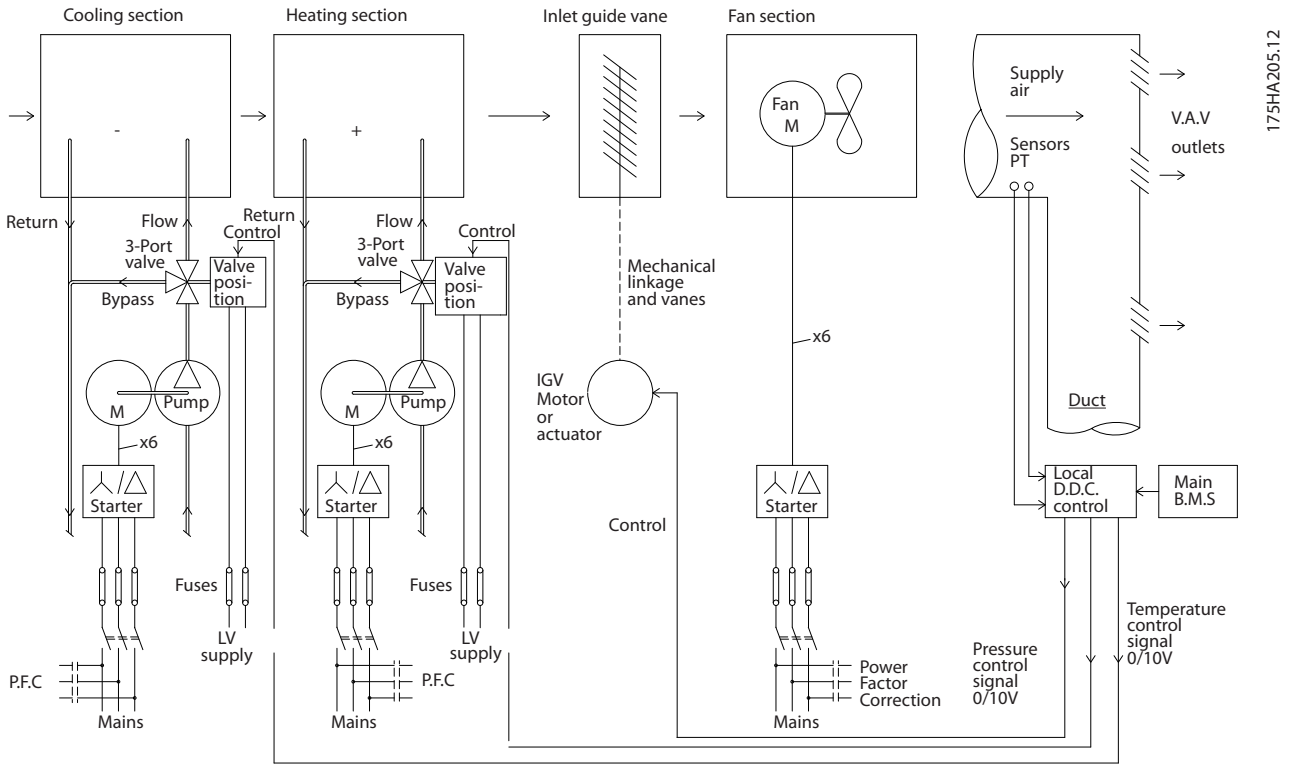

DDC	Direct digital control
VAV	Variable air volume
Sensor P	Pressure
EMS	Energy management system
Sensor T	Temperature

Illustration 5.14 Traditional Fan System



Cost with a drive

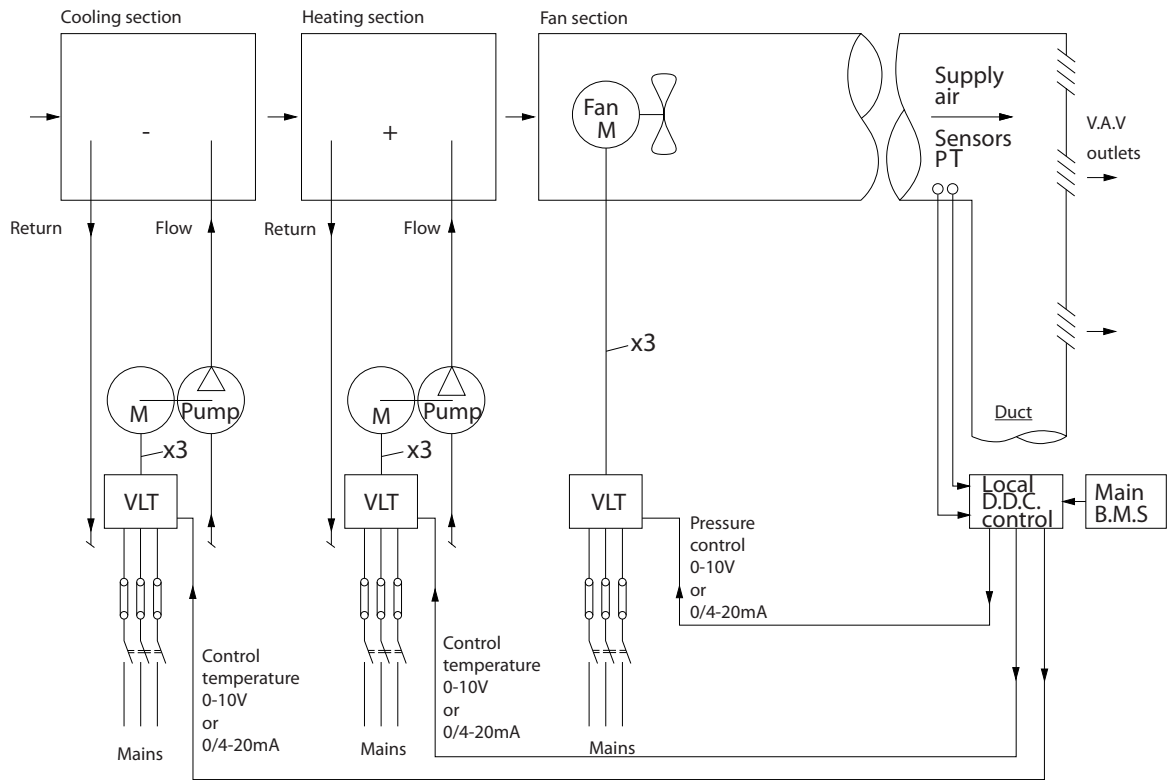

175HA206.11

5

DDC	Direct digital control
VAV	Variable air volume
BMS	Building management system

Illustration 5.15 Fan System Controlled by Drives

### 5.3.4 VLT® HVAC Solutions

#### 5.3.4.1 Variable Air Volume

Variable air volume systems (VAV) are used to control both the ventilation and temperature to fulfill the requirements of a building. Central VAV systems are considered to be the most energy-efficient method to air condition buildings. Central systems are more efficient than distributed systems.

The efficiency comes from using larger fans and chillers, which have higher efficiencies than small motors and distributed air-cooled chillers. Savings are also realized from the decreased maintenance requirements.

##### VLT® solution

While dampers and IGVs work to maintain a constant pressure in the ductwork, a drive solution saves more energy and reduces the complexity of the installation. Instead of creating an artificial pressure drop or a decrease in fan efficiency, the drive decreases the speed of the fan to provide the flow and pressure required by the system.

Centrifugal devices, such as fans, decrease the pressure and flow they produce as their speed is reduced. Their power consumption is reduced.

The return fan is frequently controlled to maintain a fixed difference in airflow between the supply and return. The advanced PID controller of the HVAC drive can be used to eliminate the need for more controllers.

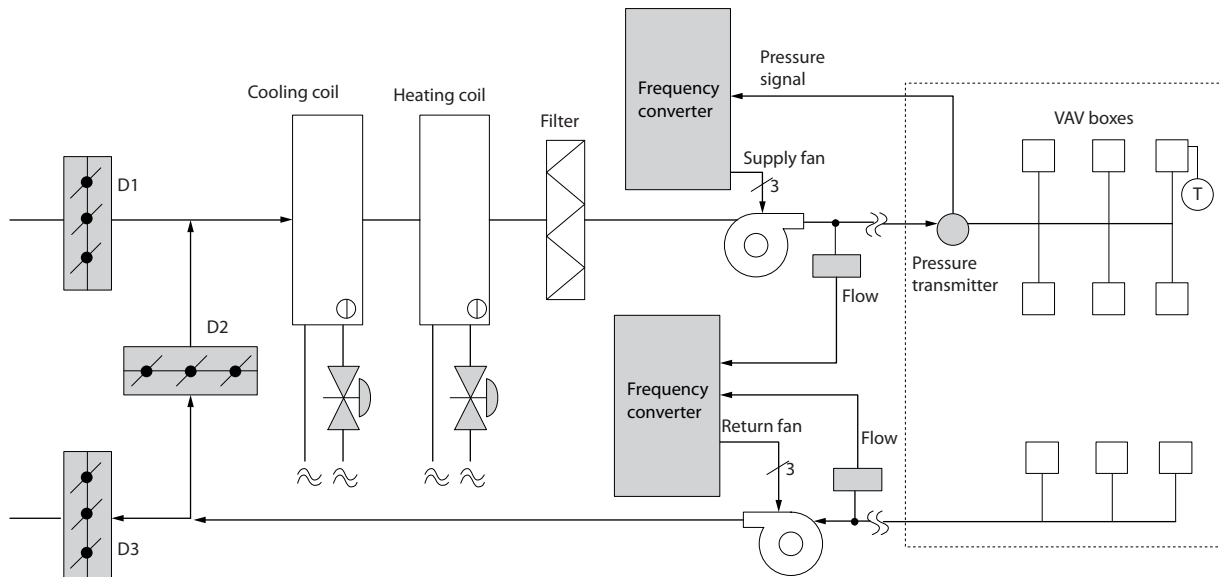

130BB455.10

Illustration 5.16 Drives Used in a Variable Air Volume System

For more information, consult the Danfoss supplier for the *Variable Air Volume: Improving VAV Ventilation Systems* application note.

#### 5.3.4.2 Constant Air Volume

Constant air volume (CAV) systems are central ventilation systems used to supply large common zones with the minimum amounts of fresh tempered air. They preceded VAV systems and are found in older multi-zoned commercial buildings as well. These systems preheat fresh air with air handling units (AHUs) that have heating coils. Many are also used for air conditioning buildings and have a cooling coil. Fan coil units are often used to help with the heating and cooling requirements in the individual zones.

##### VLT® solution

With a drive, significant energy savings can be obtained while maintaining decent control of the building. Temperature sensors or CO<sub>2</sub> sensors can be used as feedback signals to drives. Whether controlling temperature, air quality, or both, a CAV system can be controlled to operate based on actual building conditions. As the number of people in the controlled area decreases, the need for fresh air decreases. The CO<sub>2</sub> sensor detects lower levels and decreases the supply fan speed. The return fan modulates to maintain a static pressure setpoint or fixed difference between the supply and return airflows.

Temperature control needs vary based on outside temperature and number of people in the controlled zone. As the temperature decreases below the setpoint, the supply fan can decrease its speed. The return fan modulates to maintain a static pressure setpoint. Decreasing the airflow, reduces the energy used to heat or cool the fresh air, resulting in further savings.

Several features of the Danfoss HVAC dedicated drive can be used to improve the performance of a CAV system. One concern of controlling a ventilation system is poor air quality. The programmable minimum frequency can be set to maintain a minimum amount of supply air regardless of the feedback or reference signal. The drive also includes a 3-zone, 3 setpoint PID controller which allows monitoring both temperature and air quality. Even if the temperature requirement is satisfied, the drive maintains enough supply air to satisfy the air quality sensor. The controller can monitor and compare 2 feedback signals to control the return fan by maintaining a fixed differential airflow between the supply and return ducts.

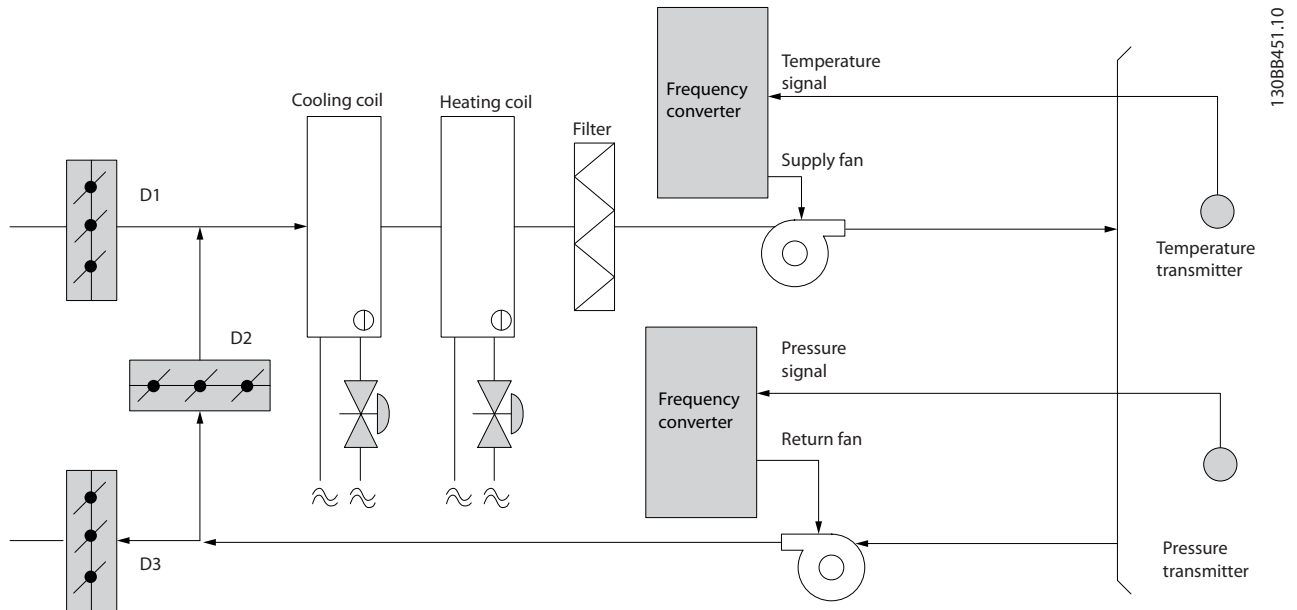

Illustration 5.17 Drive Used in a Constant Air Volume System

For more information, consult the Danfoss supplier for the *Constant Air Volume: Improving CAV Ventilation Systems* application note.

### 5.3.4.3 Cooling Tower Fan

Cooling tower fans are used to cool condenser water in water-cooled chiller systems. Water-cooled chillers provide the most efficient means of creating chilled water. They are as much as 20% more efficient than air cooled chillers. Depending on climate, cooling towers are often the most energy-efficient method of cooling the condenser water from chillers.

Cooling towers cool the condenser water by evaporation. The condenser water is sprayed into the cooling tower onto the fill to increase its surface area. The tower fan blows air through the fill and sprayed water to aid in the evaporation. Evaporation removes energy from the water, dropping its temperature. The cooled water collects in the basin of the cooling tower where it is pumped back into the chiller condenser and the cycle is repeated.

#### VLT® solution

With a drive, the cooling tower fans can be controlled to the required speed to maintain the condenser water temperature. The drives can also be used to turn the fan on and off as needed. With the Danfoss VLT® HVAC Drive, as the cooling tower fans drop below a certain speed, the cooling effect decreases. When using a gearbox to drive the tower fan, a minimum speed of 40–50% could be required. The customer programmable minimum frequency setting is available to maintain this minimum frequency even as the feedback or speed reference calls for lower speeds.

The drive can be programmed to enter a sleep mode and stop the fan until a higher speed is required. Additionally, some cooling tower fans have undesirable frequencies that can cause vibrations. These frequencies can easily be avoided by programming the bypass frequency ranges in the drive.

5

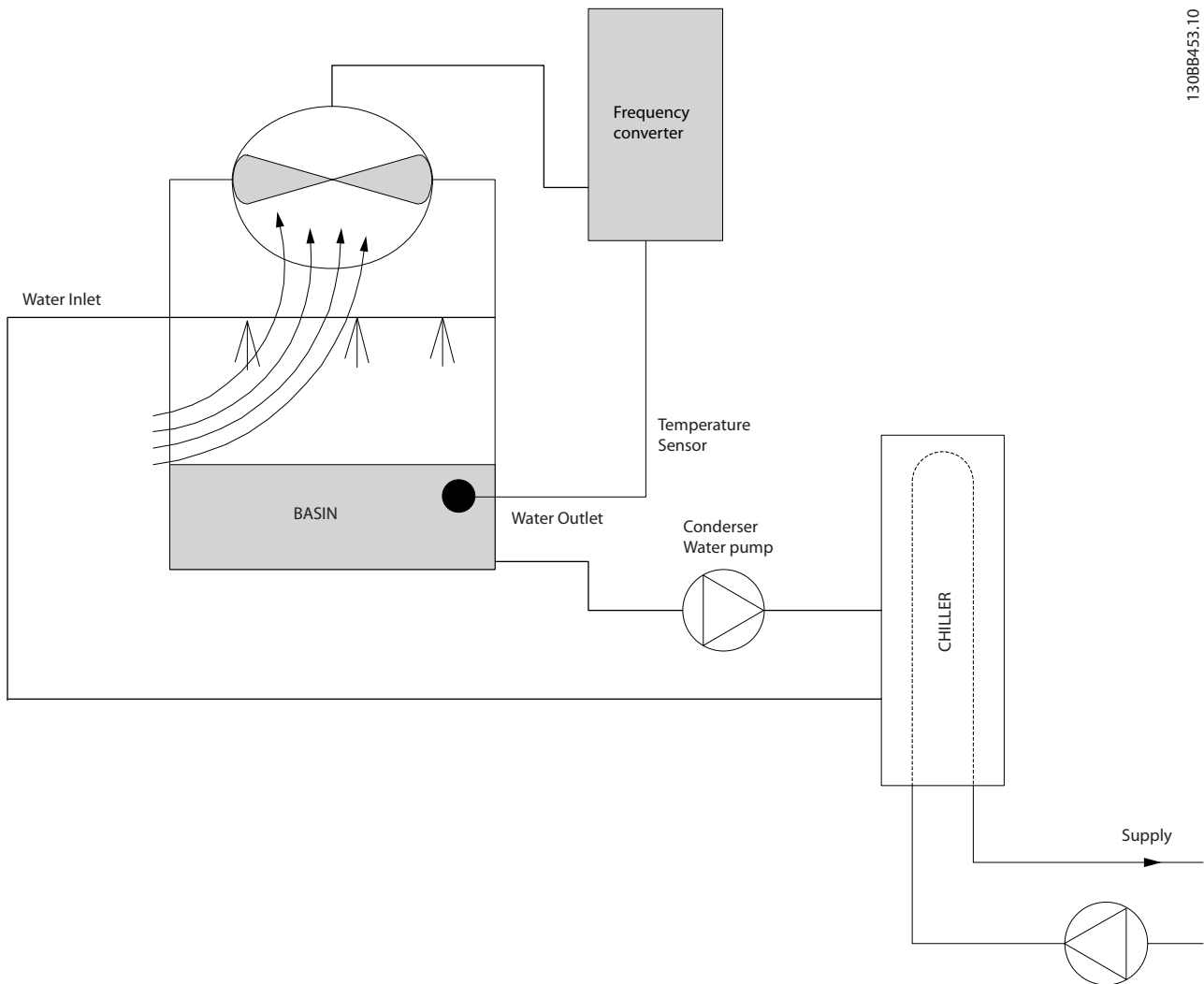

Illustration 5.18 Drives Used with a Cooling Tower Fan

For more information, consult the Danfoss supplier for the *Cooling Tower Fan: Improving Fan Control on Cooling Towers* application note.

### 5.3.4.4 Condenser Pumps

Condenser water pumps are primarily used to circulate water through the condenser section of water-cooled chillers and their associated cooling tower. The condenser water absorbs the heat from the condenser section and releases it into the atmosphere in the cooling tower. These systems provide the most efficient means of creating chilled water. They are as much as 20% more efficient than air cooled chillers.

#### VLT® solution

Drives can be added to condenser water pumps instead of balancing the pumps with a throttling valve or trimming the pump impeller.

Using a drive instead of a throttling valve saves the energy that the valve would otherwise have absorbed. This change can amount to savings of 15–20% or more. Trimming the pump impeller is irreversible. If the conditions change and higher flow is required, the impeller must be replaced.

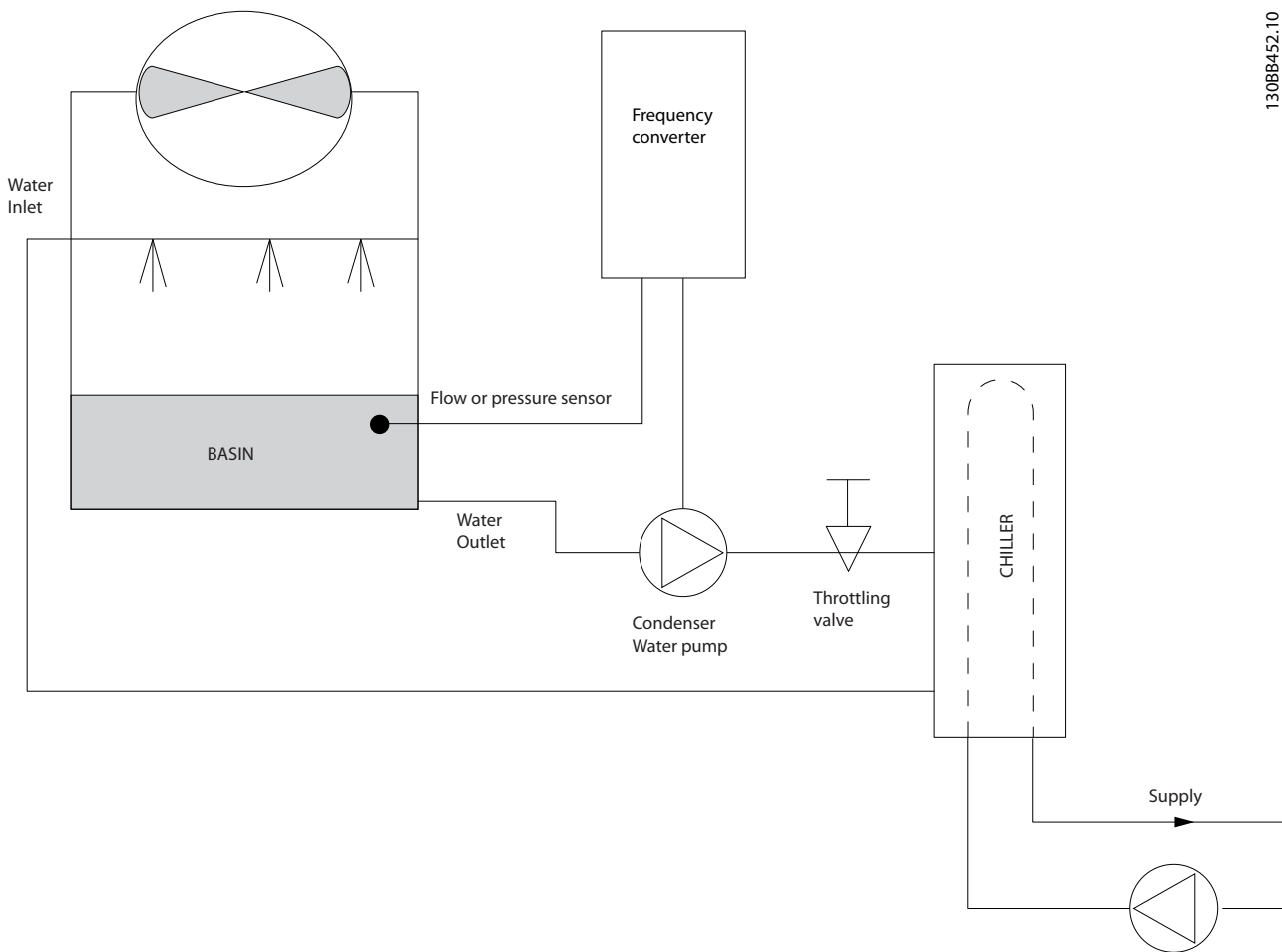

130BB452.10

5

Illustration 5.19 Drive Used with a Condenser Pump

For more information, consult the Danfoss supplier for the *Condenser Pumps: Improving Condenser Water Pumping Systems* application note.

### 5.3.4.5 Primary Pumps

Primary pumps in a primary/secondary pumping system can maintain a constant flow through devices that encounter operation or control difficulties when exposed to variable flow. The primary/secondary pumping technique decouples the primary production loop from the secondary distribution loop. Decoupling allows devices such as chillers to obtain constant design flow and operate properly while allowing the rest of the system to vary in flow. As the evaporator flow rate decreases in a chiller, the water begins to become overchilled. As the water becomes overchilled, the chiller attempts to decrease its cooling capacity. If the flow rate drops far enough, or too quickly, the chiller cannot shed its load sufficiently and the low evaporator temperature safety trips the chiller, requiring a manual reset. This situation is common in large installations, especially when 2 or more chillers in parallel are installed if primary/secondary pumping is not used.

#### VLT® solution

A drive can be added to the primary system, to replace the throttling valve and/or trimming of the impellers, leading to reduced operating expenses. Two control methods are common:

- A flow meter installed at the discharge of each chiller can control the pump directly because the desired flow rate is known and constant. Using the PID controller, the drive always maintains the appropriate flow rate, even

compensating for the changing resistance in the primary piping loop as chillers and their pumps are staged on and off.

- The operator can use local speed determination by decreasing the output frequency until the design flow rate is achieved. Using a drive to decrease the pump speed is similar to trimming the pump impeller, but more efficient. The balancing contractor simply decreases the speed of the pump until the proper flow rate is achieved and leaves the speed fixed. The pump operates at this speed any time the chiller is staged on. Because the primary loop lacks control valves or other devices that can change the system curve, and the variance due to staging pumps and chillers on and off is small, this fixed speed remains appropriate. If the flow rate must be increased later in the life of the system, the drive can simply increase the pump speed instead of requiring a new pump impeller.

5

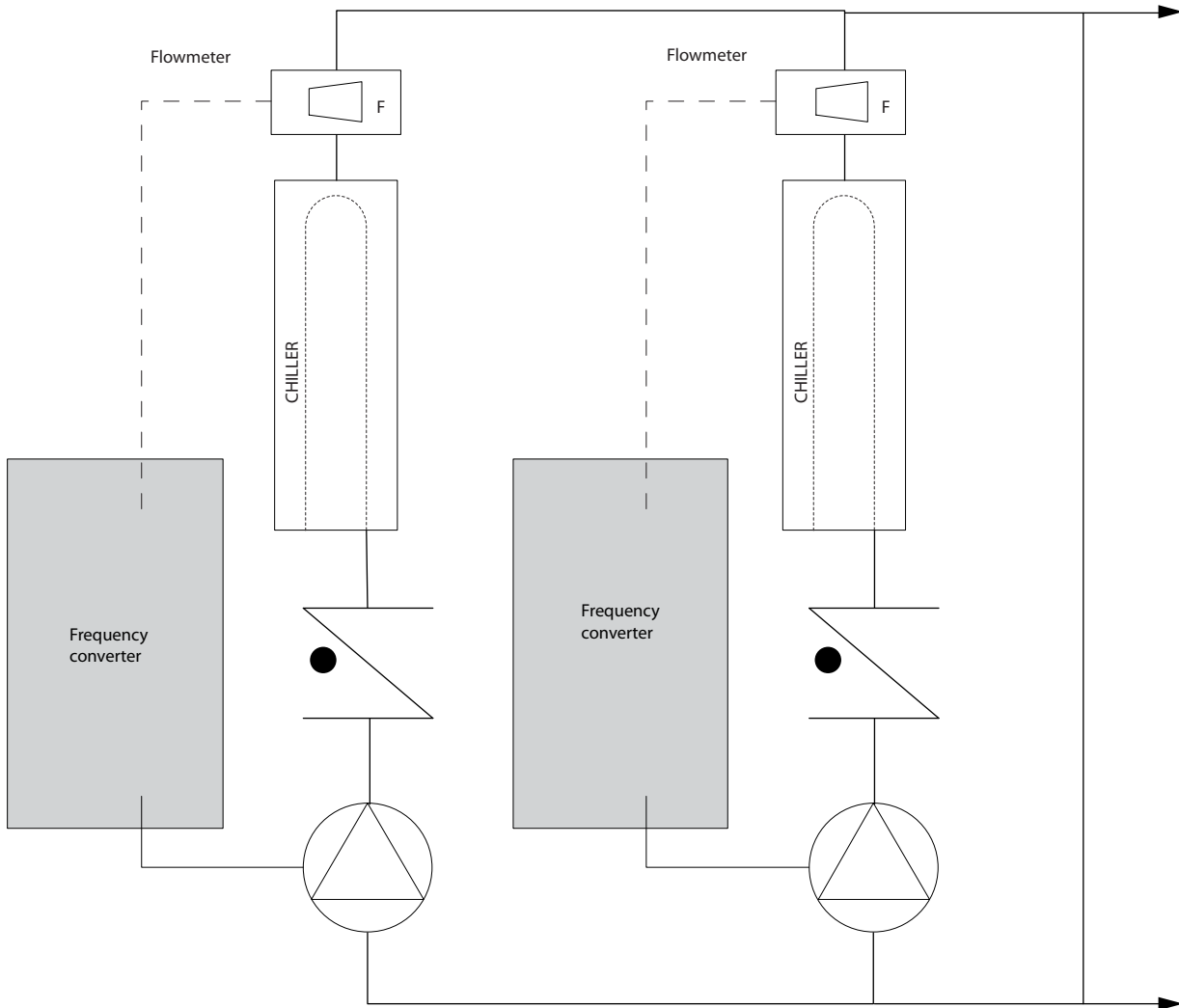

1308B456.10

Illustration 5.20 Drives Used with Primary Pumps in a Primary/Secondary Pump System

For more information, consult the Danfoss supplier for the *Primary Pumps: Improving Primary Pumping in Pri/Sec System* application note.

### 5.3.4.6 Secondary Pumps

Secondary pumps in a primary/secondary chilled water pumping system are used to distribute the chilled water to the loads from the primary production loop. The primary/secondary pumping system is used to de-couple one piping loop from another hydraulically. In this case, the primary pump maintains a constant flow through the chillers, allowing the secondary pumps to vary flow, which increases control and save energy.

If the primary/secondary design concept is not used and a variable volume system is designed, when the flow rate drops far enough or too quickly, the chiller cannot shed its load properly. The low evaporator temperature safety then trips the chiller, requiring a manual reset. This situation is common in large installations especially when 2 or more chillers in parallel are installed.

**VLT® solution**

While the primary/secondary system with 2-way valves improves energy and system control, using drives increases the energy savings and control potential further. With the proper sensor location, the addition of drives allows the pumps to match their speed to the system curve instead of the pump curve, which eliminates wasted energy and most of the over-pressurization to which 2-way valves can be subjected.

As the monitored loads are reached, the 2-way valves close down, increasing the differential pressure measured across the load and 2-way valve. As this differential pressure starts to rise, the pump is slowed to maintain the control head also called setpoint value. This setpoint value is calculated by summing the pressure drop of the load and 2-way valve together under design conditions.

**NOTICE**

When running multiple pumps in parallel, they must run at the same speed to increase energy savings, either with individual dedicated drives, or 1 drive running multiple pumps in parallel.

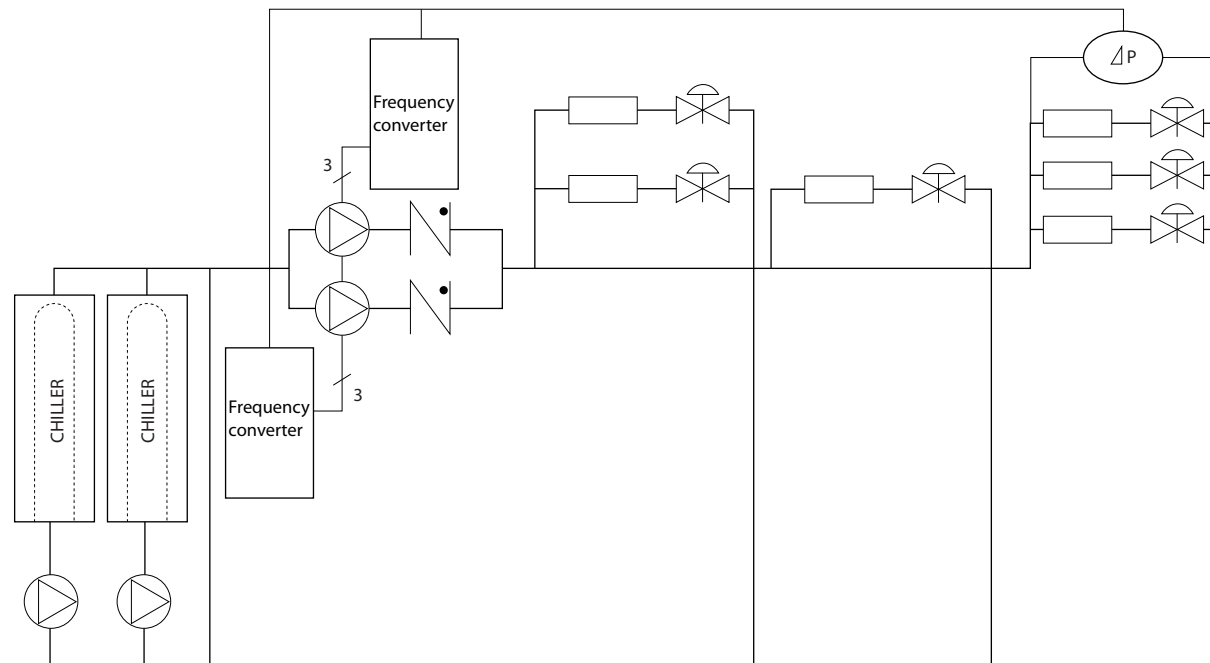

130BB454.10

Illustration 5.21 Drives Used with Secondary Pumps in a Primary/Secondary Pump System

For more information, consult the Danfoss supplier for the *Secondary Pumps: Improving Secondary Pumping in Pri/Sec System* application note.

## 5.4 Basic Cascade Controller

The basic cascade controller is used for pump applications where a certain pressure (head) or level must be maintained over a wide dynamic range. Running a large pump at variable speed over a wide range is not an ideal solution because of low pump efficiency at lower speed. In a practical way, the limit is 25% of the rated full-load speed for the pump.

In the basic cascade controller, the drive controls a variable speed (lead) motor as the variable speed pump and can stage up to 2 more constant speed pumps on and off. Connect the additional constant speed pumps directly to mains or via soft starters. By varying the speed of the initial pump, variable speed control of the entire system is provided. The variable speed maintains constant pressure, which results in reduced system stress, and quieter operation in pumping systems.

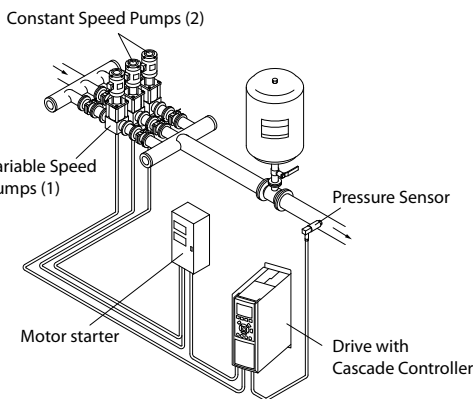

e30ba362.11

Illustration 5.22 Basic Cascade Controller

### Fixed lead pump

The motors must be of equal size. The basic cascade controller allows the drive to control up to 3 equal pumps using the 2 built-in relays in the drive. When the variable pump (lead) is connected directly to the drive, the 2 built-in relays control the other 2 pumps. When lead pump alternations are enabled, pumps are connected to the built-in relays and the drive can operate 2 pumps.

### Lead pump alternation

The motors must be of equal size. This function makes it possible to cycle the drive between the pumps in the system (maximum of 2 pumps). In this operation, the run-time between pumps is equalized, reducing the required pump maintenance and increasing reliability and lifetime of the system. The alternation of the lead pump can take place at a command signal or at staging (adding another pump).

The command can be a manual alternation or an alternation event signal. If the alternation event is selected, the lead pump alternation takes place every time the event occurs. Selections include:

- Whenever an alternation timer expires.
- At a predefined time of day.
- When the lead pump goes into sleep mode.

The actual system load determines staging.

A separate parameter limits alternation only to take place if total capacity required is >50%. Total pump capacity is determined as lead pump plus fixed speed pumps capacities.

### Bandwidth management

In cascade control systems, to avoid frequent switching of fixed-speed pumps, the desired system pressure is kept within a bandwidth rather than at a constant level. The staging bandwidth provides the required bandwidth for operation. When a large and quick change in system pressure occurs, the override bandwidth overrides the staging bandwidth to prevent immediate response to a short duration pressure change. An override bandwidth timer can be programmed to prevent staging until the system pressure has stabilized and normal control is established.

When the cascade controller is enabled and the drive issues a trip alarm, the system head is maintained by staging and destaging fixed-speed pumps. To prevent frequent staging and destaging and minimize pressure fluctuations, a wider fixed speed bandwidth is used instead of the staging bandwidth.

#### 5.4.1.1 Pump Staging with Lead Pump Alternation

With lead pump alternation enabled, a maximum of 2 pumps are controlled. At an alternation command, the PID stops, the lead pump ramps to minimum frequency ( $f_{min}$ ) and, after a delay, it ramps to maximum frequency ( $f_{max}$ ). When the speed of the lead pump reaches the destaging frequency, the fixed-speed pump is cut out (destaged). The lead pump continues to ramp up and then ramps down to a stop and the 2 relays are cut out.

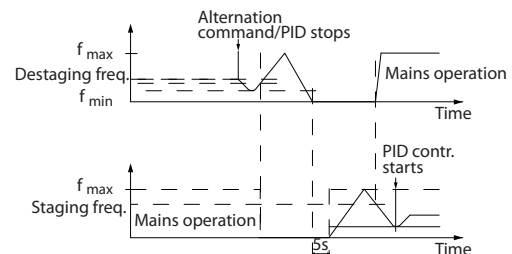

130BA364.10

Illustration 5.23 Lead Pump Alternation

After a time delay, the relay for the fixed-speed pump cuts in (staged) and this pump becomes the new lead pump. The new lead pump ramps up to maximum speed and then down to minimum speed. When ramping down and reaching the staging frequency, the old lead pump is now cut in (staged) on the mains as the new fixed-speed pump.



If the lead pump has been running at minimum frequency ( $f_{\min}$ ) for a programmed amount of time, with a fixed-speed pump running, the lead pump contributes little to the system. When the programmed value of the timer expires, the lead pump is removed, avoiding water heating problems.

#### 5.4.1.2 System Status and Operation

If the lead pump goes into sleep mode, the function is shown on the LCP. It is possible to alternate the lead pump on a sleep mode condition.

When the cascade controller is enabled, the LCP shows the operation status for each pump and the cascade controller. Information shown includes:

- Pump status is a readout of the status for the relays assigned to each pump. The display shows pumps that are disabled, off, running on the drive, or running on the mains/motor starter.
- Cascade status is a readout of the status for the cascade controller. The display shows the following:
  - Cascade controller is disabled.
  - All pumps are off.
  - An emergency has stopped all pumps.
  - All pumps are running.
  - Fixed-speed pumps are being staged/destaged.
  - Lead pump alternation is occurring.
- Destage at no-flow ensures that all fixed-speed pumps are stopped individually until the no-flow status disappears.

## 5.5 Dynamic Braking Overview

Dynamic braking slows the motor using 1 of the following methods:

- AC brake  
The brake energy is distributed in the motor by changing the loss conditions in the motor (*parameter 2-10 Brake Function = [2]*). The AC brake function cannot be used in applications with high cycling frequency since this situation overheats the motor.
- DC brake  
An overmodulated DC current added to the AC current works as an eddy current brake (*parameter 2-02 DC Braking Time  $\neq$  0 s*).
- Resistor brake  
A brake IGBT keeps the overvoltage under a certain threshold by directing the brake energy from the motor to the connected brake resistor (*parameter 2-10 Brake Function = [1]*). For more information on selecting a brake resistor, see *VLT<sup>®</sup> Brake Resistor MCE 101 Design Guide*.

For drives equipped with the brake option, a brake IGBT along with terminals 81(R-) and 82(R+) are included for connecting an external brake resistor.

The function of the brake IGBT is to limit the voltage in the DC link whenever the maximum voltage limit is exceeded. It limits the voltage by switching the externally mounted resistor across the DC bus to remove excess DC voltage present on the bus capacitors.

External brake resistor placement has the advantages of selecting the resistor based on application need, dissipating the energy outside of the control panel, and protecting the drive from overheating if the brake resistor is overloaded.

The brake IGBT gate signal originates on the control card and is delivered to the brake IGBT via the power card and gatedrive card. Also, the power and control cards monitor the brake IGBT for a short circuit. The power card also monitors the brake resistor for overloads.

## 5.6 Load Share Overview

Load share is a feature that allows the connection of DC circuits of several drives, creating a multiple-drive system to run 1 mechanical load. Load share provides the following benefits:

### Energy savings

A motor running in regenerative mode can supply drives that are running in motoring mode.

### Reduced need for spare parts

Usually, only 1 brake resistor is needed for the entire drive system instead of 1 brake resistor for per drive.

### Power back-up

If there is mains failure, all linked drives can be supplied through the DC link from a back-up. The application can continue running or go through a controlled shutdown process.

### Preconditions

The following preconditions must be met before load sharing is considered:

- The drive must be equipped with load sharing terminals.
- Product series must be the same. Only VLT® HVAC Drive drives used with other VLT® HVAC Drive drives.
- Drives must be placed physically close to one another to allow the wiring between them to be no longer than 25 m (82 ft).
- Drives must have the same voltage rating.
- When adding a brake resistor in a load sharing configuration, all drives must be equipped with a brake chopper.
- Fuses must be added to load share terminals.

For a diagram of a load share application in which best practices are applied, see *Illustration 5.24*.

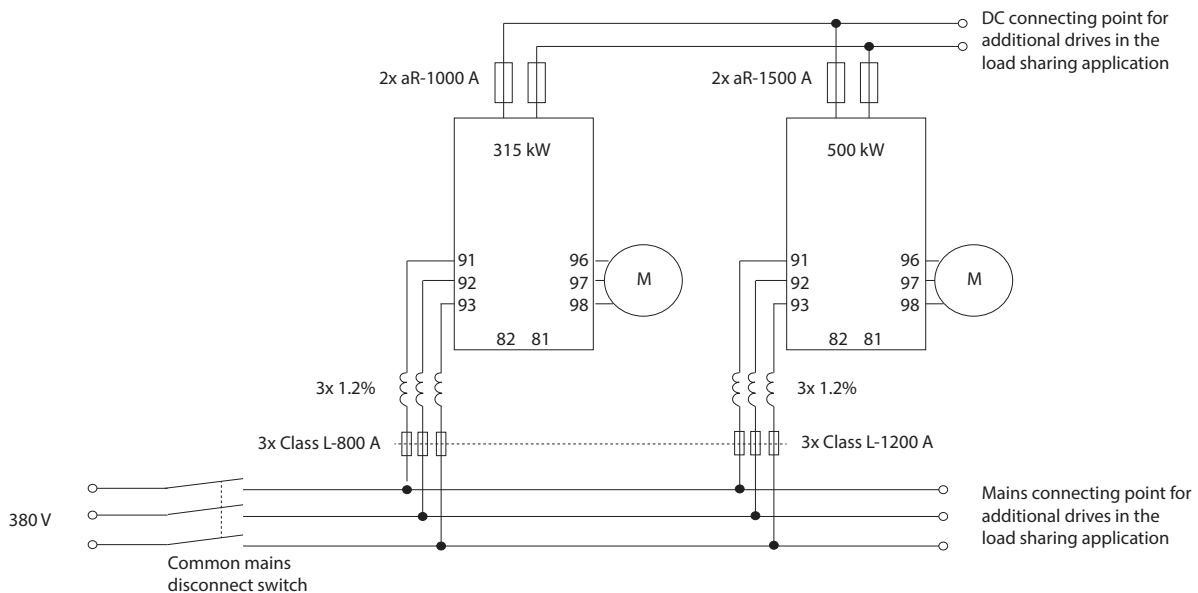

Illustration 5.24 Diagram of a Load Share Application Where Best Practices are Applied

### Load sharing

Units with the built-in load sharing option contain terminals (+) 89 DC and (-) 88 DC. Within the drive, these terminals connect to the DC bus in front of the DC-link reactor and bus capacitors.

The load sharing terminals can connect in 2 different configurations.

- Terminals tie the DC-bus circuits of multiple drives together. This configuration allows a unit that is in a regenerative mode to share its excess bus voltage with another unit that is running a motor. Load sharing in this

manner can reduce the need for external dynamic brake resistors, while also saving energy. The number of units that can be connected in this way is infinite, as long as each unit has the same voltage rating. In addition, depending on the size and number of units, it may be necessary to install DC reactors and DC fuses in the DC-link connections, and AC reactors on the mains. Attempting such a configuration requires specific considerations.

- The drive is powered exclusively from a DC source. This configuration requires:
  - A DC source.
  - A means to soft charge the DC bus at power-up.

## 5.7 Regen Overview

Regen typically occurs in applications with continuous braking such as cranes/hoists, downhill conveyors, and centrifuges where energy is pulled out of a decelerated motor.

The excess energy is removed from the drive using 1 of the following options:

- Brake chopper allows the excess energy to be dissipated in the form of heat within the brake resistor coils.
- Regen terminals allow a third-party regen unit to be connected to the drive, allowing the excess energy to be returned to the power grid.

Returning excess energy back to the power grid is the most efficient use of regenerated energy in applications using continuous braking.

## 6 Options and Accessories Overview

### 6.1 Fieldbus Devices

This section describes the fieldbus devices that are available with the VLT® HVAC Drive series. Using a fieldbus device reduces system cost, delivers faster and more efficient communication, and provides an easier user interface. For ordering numbers, refer to *chapter 13.2 Ordering Numbers for Options/Kits*.

#### 6.1.1 VLT® PROFIBUS DP-V1 MCA 101

The MCA 101 provides:

- Wide compatibility, a high level of availability, support for all major PLC vendors, and compatibility with future versions.
- Fast, efficient communication, transparent installation, advanced diagnosis, and parameterization and auto-configuration of process data via a GSD file.
- Acyclic parameterization using PROFIBUS DP-V1, PROFIdrive, or Danfoss FC profile state machines.

#### 6.1.2 VLT® DeviceNet MCA 104

The MCA 104 provides:

- Support of the ODVA AC drive profile supported via I/O instance 20/70 and 21/71 secures compatibility to existing systems.
- Benefits from ODVA's strong conformance testing policies that ensure products are interoperable.

#### 6.1.3 VLT® LonWorks MCA 108

LonWorks is a fieldbus system developed for building automation. It enables communication between individual units in the same system (peer-to-peer) and thus supports decentralizing of control.

- No need for large main station (master/slave).
- Units receive signals directly.
- Supports Echelon free-topology interface (flexible cabling and installation).
- Supports embedded I/Os and I/O options (easy implementation of de-central I/Os).
- Sensor signals can quickly be moved to another controller via bus cables.
- Certified as compliant with LonMark version 3.4 specifications.

#### 6.1.4 VLT® BACnet MCA 109

The open communications protocol for worldwide building automation use. The BACnet protocol is an international protocol that efficiently integrates all parts of building automation equipment from the actuator level to the building management system.

- BACnet is the world standard for building automation.
- International standard ISO 16484-5.
- With no license fees, the protocol can be used in building automation systems of all sizes.
- The BACnet option lets the drive communicate with building management systems running the BACnet protocol.
- BACnet is typically used for heating, ventilation, cooling, and climate equipment control.
- The BACnet protocol easily integrates into existing control equipment networks.

#### 6.1.5 VLT® PROFINET MCA 120

The MCA 120 option combines the highest performance with the highest degree of openness. The option is designed so that many of the features from the VLT® PROFIBUS MCA 101 can be reused, minimizing user effort to migrate PROFINET and securing the investment in a PLC program.

- Same PPO types as the VLT® PROFIBUS DP V1 MCA 101 for easy migration to PROFINET.
- Built-in web server for remote diagnosis and reading out of basic drive parameters.
- Supports MRP.
- Supports DP-V1. Diagnostic allows easy, fast, and standardized handling of warning and fault information into the PLC, improving bandwidth in the system.
- Supports PROFIsafe when combined with VLT® Safety Option MCB 152.
- Implementation in accordance with Conformance Class B.

### 6.1.6 VLT® EtherNet/IP MCA 121

Ethernet is the future standard for communication at the factory floor. The VLT® EtherNet/IP MCA 121 option is based on the newest technology available for industrial use and handles even the most demanding requirements. EtherNet/IP™ extends standard commercial Ethernet to the Common Industrial Protocol (CIP™) – the same upper-layer protocol and object model found in DeviceNet.

MCA 121 offers advanced features such as:

- Built-in, high-performance switch enabling line-topology, which eliminates the need for external switches.
- DLR Ring (from October 2015).
- Advanced switch and diagnosis functions.
- Built-in web server.
- E-mail client for service notification.
- Unicast and Multicast communication.

### 6.1.7 VLT® Modbus TCP MCA 122

The MCA 122 option connects to Modbus TCP-based networks. It handles connection intervals down to 5 ms in both directions, positioning it among the fastest performing Modbus TCP devices in the market. For master redundancy, it features hot swapping between 2 masters. Other features include:

- Built-in web-server for remote diagnosis and reading out basic drive parameters.
- Email notification that can be configured to send an email message to 1 or more recipients when certain alarms or warnings occur, or when they are cleared.
- Dual master PLC connection for redundancy.

### 6.1.8 VLT® BACnet/IP MCA 125

The VLT® BACnet/IP MCA 125 option allows quick and easy integration of the drive into building management systems (BMS) using the BACnet/IP protocol or by running BACnet on Ethernet. It can read and share data points and transfer actual and requested values to and from the systems.

The MCA 125 option has 2 Ethernet connectors, enabling daisy-chain configuration with no need for external switches. The embedded 3-port managed switch of the VLT® BACnet/IP MCA 125 option comprises 2 external and 1 internal Ethernet port. This switch allows the use of a line structure for the Ethernet cabling. This option makes it possible to control multiple high-efficiency permanent

magnet motors in parallel and monitor points required in typical HVAC applications. Besides standard functionality, the MCA 125 option features:

- COV (change of value).
- Read/write property multiple.
- Alarm/warning notifications
- Ability to change BACnet object names for user-friendliness.
- BACnet Loop object.
- Segmented data transfer.
- Trending, based on time or event.

## 6.2 Functional Extensions

This section describes the functional extension options that are available with the VLT® HVAC Drive series. For ordering numbers, refer to *chapter 13.2 Ordering Numbers for Options/Kits*.

### 6.2.1 VLT® General Purpose I/O Module MCB 101

The MCB 101 option offers an extended number of control inputs and outputs:

- 3 digital inputs 0–24 V: Logic 0 < 5 V; Logic 1 > 10 V.
- 2 analog inputs 0–10 V: Resolution 10 bits plus sign.
- 2 digital outputs NPN/PNP push-pull.
- 1 analog output 0/4–20 mA.
- Spring-loaded connection.

### 6.2.2 VLT® Relay Card MCB 105

The MCB 105 option extends relay functions with 3 more relay outputs.

- Protects control cable connection.
- Spring-loaded control wire connection.

**Maximum switch rate (rated load/minimum load)**  
6 minutes<sup>-1</sup>/20 s<sup>-1</sup>.

**Maximum terminal load**  
AC-1 resistive load: 240 V AC, 2 A.

### 6.2.3 VLT® Analog I/O Option MCB 109

The VLT® Analog I/O Option MCB 109 is easily fitted in the drive for upgrading to advanced performance and control using the additional inputs/outputs. This option also upgrades the drive with a battery back-up supply for the

drive's built-in clock. This battery back-up provides stable use of all timed actions used by the drive.

- 3 analog inputs, each configurable as both voltage and temperature input.
- Connection of 0–10 V analog signals as well as PT1000 and NI1000 temperature inputs.
- 3 analog outputs, each configurable as 0–10 V outputs.

### 6.2.4 VLT® PTC Thermistor Card MCB 112

The VLT® PTC Thermistor Card MCB 112 provides extra motor monitoring compared to the built-in ETR function and thermistor terminal.

- Protects the motor from overheating.
- ATEX-approved for use with Ex-d motors.
- Uses Safe Torque Off function, which is approved in accordance with SIL 2 IEC 61508.

### 6.2.5 VLT® Sensor Input Option MCB 114

The MCB 114 option protects the motor from being overheated by monitoring the temperature of motor bearings and windings.

- 3 self-detecting sensor inputs for 2 or 3-wire PT100/PT1000 sensors.
- 1 extra analog input 4–20 mA.

## 6.3 Motion Control and Relay Cards

This section describes the motion control and relay card options that are available with the VLT® AutomationDrive series. For ordering numbers, refer to *chapter 13.2 Ordering Numbers for Options/Kits*.

### 6.3.1 VLT® Extended Relay Card MCB 113

The MCB 113 option adds inputs/outputs for increased flexibility.

- 7 digital inputs.
- 2 analog outputs.
- 4 SPDT relays.
- Meets NAMUR recommendations.
- Galvanic isolation capability.

## 6.4 Brake Resistors

In applications where the motor is used as a brake, energy is generated in the motor and sent back into the drive. If the energy cannot be transported back to the motor, it increases the voltage in the drive DC line. In applications with frequent braking and/or high inertia loads, this increase can lead to an overvoltage trip in the drive and, finally, a shutdown. Brake resistors are used to dissipate the excess energy resulting from the regenerative braking. The resistor is selected based on its ohmic value, its power dissipation rate, and its physical size. Danfoss offers a wide variety of different resistors that are specially designed to Danfoss drives. For ordering numbers and more information on how to dimension brake resistors, refer to the *VLT® Brake Resistor MCE 101 Design Guide*.

## 6.5 Sine-wave Filters

When a drive controls a motor, resonance noise is heard from the motor. This noise, which is the result of the motor design, occurs every time an inverter switch in the drive is activated. The frequency of the resonance noise thus corresponds to the switching frequency of the drive.

Danfoss supplies a sine-wave filter to dampen the acoustic motor noise. The filter reduces the ramp-up time of the voltage, the peak load voltage ( $U_{PEAK}$ ), and the ripple current ( $\Delta I$ ) to the motor, which means that current and voltage become almost sinusoidal. The acoustic motor noise is reduced to a minimum.

The ripple current in the sine-wave filter coils also causes some noise. Solve the problem by integrating the filter in a cabinet or enclosure.

For ordering numbers and more information on sine-wave filters, refer to the *Output Filters Design Guide*.

## 6.6 dU/dt Filters

Danfoss supplies dU/dt filters which are differential mode, low-pass filters that reduce motor terminal phase-to-phase peak voltages and reduce the rise time to a level that lowers the stress on the insulation at the motor windings. This is a typical issue with set-ups using short motor cables.

Compared to sine-wave filters, the dU/dt filters have a cut-off frequency above the switching frequency.

For ordering numbers and more information on dU/dt filters, refer to the *Output Filters Design Guide*.

## 6.7 Common-mode Filters

High-frequency common-mode cores (HF-CM cores) reduce electromagnetic interference and eliminate bearing damage by electrical discharge. They are special nanocrystalline magnetic cores that have superior filtering performance compared to regular ferrite cores. The HF-CM core acts like a common-mode inductor between phases and ground.

Installed around the 3 motor phases (U, V, W), the common mode filters reduce high-frequency common-mode currents. As a result, high-frequency electromagnetic interference from the motor cable is reduced.

For ordering numbers refer to the *Output Filters Design Guide*.

## 6.8 Harmonic Filters

The VLT<sup>®</sup> Advanced Harmonic Filters AHF 005 & AHF 010 should not be compared with traditional harmonic trap filters. The Danfoss harmonic filters have been specially designed to match the Danfoss drives.

By connecting the AHF 005 or AHF 010 in front of a Danfoss drive, the total harmonic current distortion generated back to the mains is reduced to 5% and 10%.

For ordering numbers and more information on how to dimension brake resistors, refer to the *VLT<sup>®</sup> Advanced Harmonic Filters AHF 005/AHF 010 Design Guide*.

## 6.9 Enclosure Built-in Options

The following built-in options are specified in the type code when ordering the drive.

### Enclosure with corrosion-resistant back channel

For extra protection from corrosion in harsh environments, units can be ordered in an enclosure that includes a stainless steel back channel, heavier plated heat sinks, and an upgraded fan. This option is recommended in salt-air environments, such as those near the ocean.

### Mains shielding

Lexan<sup>®</sup> shielding can be mounted in front of incoming power terminals and input plate to protect against physical contact when the enclosure door is open.

### Space heaters and thermostat

Mounted in the cabinet interior of enclosure size F drives and controlled via an automatic thermostat, space heaters controlled via an automatic thermostat prevent condensation inside the enclosure.

The thermostat default settings turn on the heaters at 10 °C (50 °F) and turn them off at 15.6 °C (60 °F).

### Cabinet light with power outlet

To increase visibility during servicing and maintenance, a light can be mounted on the cabinet interior of enclosure F drives. The light housing includes a power outlet for temporarily powering laptop computers or other devices. Available in 2 voltages:

- 230 V, 50 Hz, 2.5 A, CE/ENEC
- 120 V, 60 Hz, 5 A, UL/cUL

### RFI filters

VLT<sup>®</sup> drive series feature integrated Class A2 RFI filters as standard. If extra levels of RFI/EMC protection are required, they can be obtained using optional Class A1 RFI filters, which provide suppression of radio frequency interference and electromagnetic radiation in accordance with EN 55011. Marine use RFI filters are also available.

On enclosure size F drives, the Class A1 RFI filter requires the addition of the options cabinet.

### Insulation resistance monitor (IRM)

Monitors the insulation resistance in ungrounded systems (IT systems in IEC terminology) between the system phase conductors and ground. There is an ohmic pre-warning and a main alarm setpoint for the insulation level. Associated with each setpoint is an SPDT alarm relay for external use. Only 1 insulation resistance monitor can be connected to each ungrounded (IT) system.

- Integrated into the safe-stop circuit.
- LCD display of insulation resistance.
- Fault memory.
- Info, test, and reset key.

### Residual current device (RCD)

Uses the core balance method to monitor ground fault currents in grounded and high-resistance grounded systems (TN and TT systems in IEC terminology). There is a pre-warning (50% of main alarm setpoint) and a main alarm setpoint. Associated with each setpoint is an SPDT alarm relay for external use. Requires an external window-type current transformer (supplied and installed by customer).

- Integrated into the safe-stop circuit.
- IEC 60755 Type B device monitors, pulsed DC, and pure DC ground fault currents.
- LED bar graph indicator of the ground fault current level from 10–100% of the setpoint.
- Fault memory.
- Test and reset key.

### Safe Torque Off with Pilz safety relay

Available for drives with enclosure size F. Enables the Pilz relay to fit in the enclosure without requiring an options cabinet. The relay is used in the external temperature monitoring option. If PTC monitoring is required, order the VLT<sup>®</sup> PTC Thermistor Card MCB 112.

**Emergency stop with Pilz safety relay**

Includes a redundant 4-wire emergency stop push button mounted on the front of the enclosure, and a Pilz relay that monitors it along with the safe-stop circuit and contactor position. Requires a contactor and the options cabinet for drives with enclosure size F.

**Brake chopper (IGBTs)**

Brake terminals with an IGBT brake chopper circuit allow for the connection of external brake resistors. For detailed data on brake resistors, see the *VLT® Brake Resistor MCE 101 Design Guide*, available at [drives.danfoss.com/downloads/portal/#/](http://drives.danfoss.com/downloads/portal/#/).

**Regen terminals**

Allow connection of regen units to the DC bus on the capacitor bank side of the DC-link reactors for regenerative braking. The enclosure size F regen terminals are sized for approximately 50% the power rating of the drive. Consult the factory for regen power limits based on the specific drive size and voltage.

**Load sharing terminals**

These terminals connect to the DC-bus on the rectifier side of the DC-link reactor and allow for the sharing of DC bus power between multiple drives. For drives with enclosure size F, the load sharing terminals are sized for approximately 33% of the power rating of the drive. Consult the factory for load sharing limits based on the specific drive size and voltage.

**Disconnect**

A door-mounted handle allows for the manual operation of a power disconnect switch to enable and disable power to the drive, increasing safety during servicing. The disconnect is interlocked with the cabinet doors to prevent them from being opened while power is still applied.

**Circuit breakers**

A circuit breaker can be remotely tripped, but must be manually reset. Circuit breakers are interlocked with the cabinet doors to prevent them from being opened while power is still applied. When a circuit breaker is ordered as an option, fuses are also included for fast-acting current overload protection of the AC drive.

**Contactors**

An electrically-controlled contactor switch allows for the remote enabling and disabling of power to the drive. If the IEC emergency stop option is ordered, the Pilz relay monitors the auxiliary contact on the contactor.

**Manual motor starters**

Provide 3-phase power for electric cooling blowers that are often required for larger motors. Power for the starters is provided from the load side of any supplied contactor, circuit breaker, or disconnect switch. If a Class 1 RFI filter option is ordered, the input side of the RFI provides the power to the starter. Power is fused before each motor starter and is off when the incoming power to the drive is off. Up to 2 starters are allowed. If a 30 A fuse-protected

circuit is ordered, then only 1 starter is allowed. Starters are integrated into the safe-stop circuit. Features include:

- Operation switch (on/off).
- Short circuit and overload protection with test function.
- Manual reset function.

**30 A, fuse-protected terminals**

- 3-phase power matching incoming mains voltage for powering auxiliary customer equipment.
- Not available if 2 manual motor starters are selected.
- Terminals are off when the incoming power to the drive is off.
- Power for the terminals is provided from the load side of any supplied contactor, circuit breaker, or disconnect switch. If a Class 1 RFI filter option is ordered, the input side of the RFI provides the power to the starter.

**Common motor terminals**

The common motor terminal option provides the busbars and hardware required to connect the motor terminals from the paralleled inverters to a single terminal (per phase) to accommodate the installation of the motor-side top entry kit.

This option is also recommended to connect the output of a drive to an output filter or output contactor. The common motor terminals eliminate the need for equal cable lengths from each inverter to the common point of the output filter (or motor).

**24 V DC supply**

- 5 A, 120 W, 24 V DC.
- Protected against output overcurrent, overload, short circuits, and overtemperature.
- For powering customer-supplied accessory devices such as sensors, PLC I/O, contactors, temperature probes, indicator lights, and/or other electronic hardware.
- Diagnostics include a dry DC-ok contact, a green DC-ok LED, and a red overload LED.

**External temperature monitoring**

Designed for monitoring temperatures of external system components, such as the motor windings and/or bearings. Includes 8 universal input modules plus 2 dedicated thermistor input modules. All 10 modules are integrated into the safe-stop circuit and can be monitored via a fieldbus network, which requires the purchase of a separate module/bus coupler. A Safe Torque Off brake option must be ordered when selecting external temperature monitoring.



**Signal types**

- RTD inputs (including Pt100) – 3-wire or 4-wire.
- Thermocouple.
- Analog current or analog voltage.

**More features**

- 1 universal output – configurable for analog voltage or analog current.
- 2 output relays (NO).
- Dual-line LC display and LED diagnostics.
- Sensor lead wire break, short circuit, and incorrect polarity detection.
- Sensor lead wire break, short circuit, and incorrect polarity detection.
- Interface set-up software.
- If 3 PTC are required, the VLT<sup>®</sup> PTC Thermistor Card MCB 112 option must be added.

Ordering numbers for enclosure built-in options can be found in *chapter 13.1 Drive Configurator*.

## 6.10 High-power Kits

High-power kits, such as back-wall cooling, space heater, mains shield, are available. See *chapter 13.2 Ordering Numbers for Options/Kits* for a brief description and ordering numbers for all available kits.

## 7 Specifications

### 7.1 Electrical Data, 380–480 V

VLT® HVAC Drive FC 102	P355	P400	P450
<b>Normal overload</b> (Normal overload=110% current during 60 s)	<b>NO</b>	<b>NO</b>	<b>NO</b>
Typical shaft output at 400 V [kW]	355	400	450
Typical shaft output at 460 V [hp]	500	600	600
Typical shaft output at 480 V [kW]	400	500	530
<b>Enclosure size</b>	<b>E1/E2</b>	<b>E1/E2</b>	<b>E1/E2</b>
<b>Output current (3-phase)</b>			
Continuous (at 400 V) [A]	658	745	800
Intermittent (60 s overload) (at 400 V) [A]	724	820	880
Continuous (at 460/480 V) [A]	590	678	730
Intermittent (60 s overload) (at 460/480 V) [A]	649	746	803
Continuous kVA (at 400 V) [kVA]	456	516	554
Continuous kVA (at 460 V) [kVA]	470	540	582
Continuous kVA (at 480 V) [kVA]	511	587	632
<b>Maximum input current</b>			
Continuous (at 400 V) [A]	634	718	771
Continuous (at 460/480 V) [A]	569	653	704
<b>Maximum number and size of cables per phase</b>			
Mains and motor [mm <sup>2</sup> (AWG)]	4x240 (4x500 mcm)	4x240 (4x500 mcm)	4x240 (4x500 mcm)
Brake [mm <sup>2</sup> (AWG)]	2x185 (2x350 mcm)	2x185 (2x350 mcm)	2x185 (2x350 mcm)
Load share [mm <sup>2</sup> (AWG)]	4x240 (4x500 mcm)	4x240 (4x500 mcm)	4x240 (4x500 mcm)
Maximum external mains fuses [A] <sup>1)</sup>	900	900	900
Estimated power loss at 400 V [W] <sup>2), 3)</sup>	7532	8677	9473
Estimated power loss at 460 V [W] <sup>2), 3)</sup>	6724	7819	8527
Efficiency <sup>3)</sup>	0.98	0.98	0.98
Output frequency [Hz]	0–590	0–590	0–590
Control card overtemperature trip [°C (°F)]	85 (185)	85 (185)	85 (185)

**Table 7.1 Electrical Data for Enclosures E1/E2, Mains Supply 3x380–480 V AC**

1) For fuse ratings, see chapter 10.5 Fuses and Circuit Breakers.

2) Typical power loss is at normal conditions and expected to be within  $\pm 15\%$  (tolerance relates to variety in voltage and cable conditions). These values are based on a typical motor efficiency (IE/IE3 border line). Lower efficiency motors add to the power loss in the drive. Applies for dimensioning of drive cooling. If the switching frequency is higher than the default setting, the power losses can increase. LCP and typical control card power consumptions are included. For power loss data according to EN 50598-2, refer to [drives.danfoss.com/knowledge-center/energy-efficiency-directive/#/](http://drives.danfoss.com/knowledge-center/energy-efficiency-directive/#/). Options and customer load can add up to 30 W to the losses, though usually a fully loaded control card and options for slots A and B each add only 4 W.

3) Measured using 5 m (16.5 ft) shielded motor cables at rated load and rated frequency. Efficiency measured at nominal current. For energy efficiency class, see chapter 10.12 Efficiency. For part load losses, see [drives.danfoss.com/knowledge-center/energy-efficiency-directive/#/](http://drives.danfoss.com/knowledge-center/energy-efficiency-directive/#/).

VLT® HVAC Drive FC 102	P500	P560	P630	P710
<b>Normal overload</b> (Normal overload=110% current during 60 s)	<b>NO</b>	<b>NO</b>	<b>NO</b>	<b>NO</b>
Typical shaft output at 400 V [kW]	500	560	630	710
Typical shaft output at 460 V [hp]	650	750	900	1000
Typical shaft output at 480 V [kW]	560	630	710	800
<b>Enclosure size</b>	<b>F1/F3</b>	<b>F1/F3</b>	<b>F1/F3</b>	<b>F1/F3</b>
<b>Output current (3-phase)</b>				
Continuous (at 400 V) [A]	880	990	1120	1260
Intermittent (60 s overload) (at 400 V) [A]	968	1089	1680	1890
Continuous (at 460/480 V) [A]	780	890	1050	1160
Intermittent (60 s overload) (at 460/480 V) [A]	858	979	1155	1276
Continuous kVA (at 400 V) [kVA]	610	686	776	873
Continuous kVA (at 460 V) [kVA]	621	709	837	924
Continuous kVA (at 480 V) [kVA]	675	771	909	1005
<b>Maximum input current</b>				
Continuous (at 400 V) [A]	848	954	1079	1214
Continuous (at 460/480 V) [A]	752	858	1012	1118
<b>Maximum number and size of cables per phase</b>				
- Motor [mm <sup>2</sup> (AWG)]	8x150 (8x300 mcm)	8x150 (8x300 mcm)	8x150 (8x300 mcm)	8x150 (8x300 mcm)
- Mains [mm <sup>2</sup> (AWG)] (F1)	8x240 (8x500 mcm)	8x240 (8x500 mcm)	8x240 (8x500 mcm)	8x240 (8x500 mcm)
- Mains [mm <sup>2</sup> (AWG)] (F3)	8x456 (8x900 mcm)	8x456 (8x900 mcm)	8x456 (8x900 mcm)	8x456 (8x900 mcm)
- Load share [mm <sup>2</sup> (AWG)]	8x120 (8x250 mcm)	8x120 (8x250 mcm)	8x120 (8x250 mcm)	8x120 (8x250 mcm)
- Brake [mm <sup>2</sup> (AWG)]	8x185 (8x350 mcm)	8x185 (8x350 mcm)	8x185 (8x350 mcm)	8x185 (8x350 mcm)
Maximum external mains fuses [A] <sup>1)</sup>	1600	1600	2000	2000
Estimated power loss at 400 V [W] <sup>2), 3)</sup>	10162	11822	12512	14674
Estimated power loss at 460 V [W] <sup>2), 3)</sup>	8876	10424	11595	13213
Maximum added losses A1 RFI, circuit breaker or disconnect, and contactor [W], (F3 only)	963	1054	1093	1230
Maximum panel options losses [W]	400	400	400	400
Efficiency <sup>3)</sup>	0.98	0.98	0.98	0.98
Output frequency [Hz]	0–590	0–590	0–590	0–590
Control card overtemperature trip [°C (°F)]	85 (185)	85 (185)	85 (185)	85 (185)

**7**
**Table 7.2 Electrical Data for Enclosures F1/F3, Mains Supply 3x380–480 V AC**

1) For fuse ratings, see chapter 10.5 Fuses and Circuit Breakers.

2) Typical power loss is at normal conditions and expected to be within ±15% (tolerance relates to variety in voltage and cable conditions). These values are based on a typical motor efficiency (IE/IE3 border line). Lower efficiency motors add to the power loss in the drive. Applies for dimensioning of drive cooling. If the switching frequency is higher than the default setting, the power losses can increase. LCP and typical control card power consumptions are included. For power loss data according to EN 50598-2, refer to [drives.danfoss.com/knowledge-center/energy-efficiency-directive/#/](http://drives.danfoss.com/knowledge-center/energy-efficiency-directive/#/). Options and customer load can add up to 30 W to the losses, though usually a fully loaded control card and options for slots A and B each add only 4 W.

3) Measured using 5 m (16.5 ft) shielded motor cables at rated load and rated frequency. Efficiency measured at nominal current. For energy efficiency class, see chapter 10.12 Efficiency. For part load losses, see [drives.danfoss.com/knowledge-center/energy-efficiency-directive/#/](http://drives.danfoss.com/knowledge-center/energy-efficiency-directive/#/).

VLT® HVAC Drive FC 102	P800	P1000
<b>Normal overload</b> (Normal overload=110% current during 60 s)	<b>NO</b>	<b>NO</b>
Typical shaft output at 400 V [kW]	800	1000
Typical shaft output at 460 V [hp]	1200	1350
Typical shaft output at 480 V [kW]	1000	1100
<b>Enclosure size</b>	<b>F2/F4</b>	<b>F2/F4</b>
<b>Output current (3-phase)</b>		
Continuous (at 400 V) [A]	1460	1720
Intermittent (60 s overload) (at 400 V) [A]	1606	1892
Continuous (at 460/480 V) [A]	1380	1530
Intermittent (60 s overload)(at 460/480 V) [A]	1518	1683
Continuous kVA (at 400 V) [kVA]	1012	1192
Continuous kVA (at 460 V) [kVA]	1100	1219
Continuous kVA (at 480 V) [kVA]	1195	1325
<b>Maximum input current</b>		
Continuous (at 400 V) [A]	1407	1658
Continuous (at 460/480 V) [A]	1330	1474
<b>Maximum number and size of cables per phase</b>		
- Motor [mm <sup>2</sup> (AWG)]	12x150 (12x300 mcm)	12x150 (12x300 mcm)
- Mains [mm <sup>2</sup> (AWG)] (F2)	8x240 (8x500 mcm)	8x240 (8x500 mcm)
- Mains [mm <sup>2</sup> (AWG)] (F4)	8x456 (8x900 mcm)	8x456 (8x900 mcm)
- Load share [mm <sup>2</sup> (AWG)]	4x120 (4x250 mcm)	4x120 (4x250 mcm)
- Brake [mm <sup>2</sup> (AWG)]	6x185 (6x350 mcm)	6x185 (6x350 mcm)
Maximum external mains fuses [A] <sup>1)</sup>	2500	2500
Estimated power loss at 400 V [W] <sup>2), 3)</sup>	17293	19278
Estimated power loss at 460 V [W] <sup>2), 3)</sup>	16229	16624
Maximum added losses A1 RFI, circuit breaker or disconnect, and contactor [W], (F4 only)	2280	2541
Maximum panel options losses [W]	400	400
Efficiency <sup>3)</sup>	0.98	0.98
Output frequency [Hz]	0–590	0–590
Control card overtemperature trip [°C (°F)]	85 (185)	85 (185)

**Table 7.3 Electrical Data for Enclosures F2/F4, Mains Supply 3x380–480 V AC**

1) For fuse ratings, see chapter 10.5 Fuses and Circuit Breakers.

2) Typical power loss is at normal conditions and expected to be within ±15% (tolerance relates to variety in voltage and cable conditions). These values are based on a typical motor efficiency (IE/IE3 border line). Lower efficiency motors add to the power loss in the drive. Applies for dimensioning of drive cooling. If the switching frequency is higher than the default setting, the power losses can increase. LCP and typical control card power consumptions are included. For power loss data according to EN 50598-2, refer to [drives.danfoss.com/knowledge-center/energy-efficiency-directive/#/](http://drives.danfoss.com/knowledge-center/energy-efficiency-directive/#/). Options and customer load can add up to 30 W to the losses, though usually a fully loaded control card and options for slots A and B each add only 4 W.

3) Measured using 5 m (16.5 ft) shielded motor cables at rated load and rated frequency. Efficiency measured at nominal current. For energy efficiency class, see chapter 10.12 Efficiency. For part load losses, see [drives.danfoss.com/knowledge-center/energy-efficiency-directive/#/](http://drives.danfoss.com/knowledge-center/energy-efficiency-directive/#/).

VLT® HVAC Drive FC 102	P355	P400	P450
<b>Normal overload</b> (Normal overload=110% current during 60 s)	<b>NO</b>	<b>NO</b>	<b>NO</b>
Typical shaft output at 400 V [kW]	355	400	450
Typical shaft output at 460 V [hp]	500	600	600
Typical shaft output at 480 V [kW]	400	500	530
<b>Enclosure size</b>	<b>F8/F9</b>	<b>F8/F9</b>	<b>F8/F9</b>
<b>Output current (3-phase)</b>			
Continuous (at 400 V) [A]	658	745	800
Intermittent (60 s overload) (at 400 V) [A]	724	820	880
Continuous (at 460/480 V) [A]	590	678	730
Intermittent (60 s overload) (at 460/480 V) [A]	649	746	803
Continuous kVA (at 400 V) [kVA]	456	516	554
Continuous kVA (at 460 V) [kVA]	470	540	582
Continuous kVA (at 480 V) [kVA]	511	587	632
<b>Maximum input current</b>			
Continuous (at 400 V) [A]	634	718	771
Continuous (at 460/480 V) [A]	569	653	704
<b>Maximum number and size of cables per phase</b>			
- Motor [mm <sup>2</sup> (AWG)]	4x240 (4x500 mcm)	4x240 (4x500 mcm)	4x240 (4x500 mcm)
- Mains [mm <sup>2</sup> (AWG)]	4x90 (4x3/0 mcm)	4x240 (4x500 mcm)	4x240 (4x500 mcm)
- Brake [mm <sup>2</sup> (AWG)]	2x185 (2x350 mcm)	2x185 (2x350 mcm)	2x185 (2x350 mcm)
Maximum external mains fuses [A] <sup>1)</sup>	700	700	700
Estimated power loss at 400 V [W] <sup>2), 3)</sup>	7701	8879	9670
Estimated power loss at 460 V [W] <sup>2), 3)</sup>	6953	8089	8803
Efficiency <sup>3)</sup>	0.98	0.98	0.98
Output frequency [Hz]	0–590	0–590	0–590
Control card overtemperature trip [°C (°F)]	85 (185)	85 (185)	85 (185)

7

**Table 7.4 Electrical Data for Enclosures F8/F9, Mains Supply 6x380–480 V AC**

1) For fuse ratings, see chapter 10.5 Fuses and Circuit Breakers.

2) Typical power loss is at normal conditions and expected to be within ±15% (tolerance relates to variety in voltage and cable conditions). These values are based on a typical motor efficiency (IE/IE3 border line). Lower efficiency motors add to the power loss in the drive. Applies for dimensioning of drive cooling. If the switching frequency is higher than the default setting, the power losses can increase. LCP and typical control card power consumptions are included. For power loss data according to EN 50598-2, refer to [drives.danfoss.com/knowledge-center/energy-efficiency-directive/#/](http://drives.danfoss.com/knowledge-center/energy-efficiency-directive/#/). Options and customer load can add up to 30 W to the losses, though usually a fully loaded control card and options for slots A and B each add only 4 W.

3) Measured using 5 m (16.5 ft) shielded motor cables at rated load and rated frequency. Efficiency measured at nominal current. For energy efficiency class, see chapter 10.12 Efficiency. For part load losses, see [drives.danfoss.com/knowledge-center/energy-efficiency-directive/#/](http://drives.danfoss.com/knowledge-center/energy-efficiency-directive/#/).

VLT® HVAC Drive FC 102	P500	P560	P630	P710
<b>Normal overload</b> (Normal overload=110% current during 60 s)	<b>NO</b>	<b>NO</b>	<b>NO</b>	<b>NO</b>
Typical shaft output at 400 V [kW]	500	560	630	710
Typical shaft output at 460 V [hp]	650	750	900	1000
Typical shaft output at 480 V [kW]	560	630	710	800
<b>Enclosure size</b>	<b>F10/F11</b>	<b>F10/F11</b>	<b>F10/F11</b>	<b>F10/F11</b>
<b>Output current (3-phase)</b>				
Continuous (at 400 V) [A]	880	990	1120	1260
Intermittent (60 s overload) (at 400 V) [A]	968	1089	1232	1386
Continuous (at 460/480 V) [A]	780	890	1050	1160
Intermittent (60 s overload) (at 460/480 V) [A]	858	979	1155	1276
Continuous kVA (at 400 V) [kVA]	610	686	776	873
Continuous kVA (at 460 V) [kVA]	621	709	837	924
Continuous kVA (at 480 V) [kVA]	675	771	909	1005
<b>Maximum input current</b>				
Continuous (at 400 V) [A]	848	954	1079	1214
Continuous (at 460/480 V) [A]	752	858	1012	1118
<b>Maximum number and size of cables per phase</b>				
- Motor [mm <sup>2</sup> (AWG)]	8x150 (8x300 mcm)	8x150 (8x300 mcm)	8x150 (8x300 mcm)	8x150 (8x300 mcm)
- Mains [mm <sup>2</sup> (AWG)]	6x120 (6x250 mcm)	6x120 (6x250 mcm)	6x120 (6x250 mcm)	6x120 (6x250 mcm)
- Brake [mm <sup>2</sup> (AWG)]	4x185 (4x350 mcm)	4x185 (4x350 mcm)	4x185 (4x350 mcm)	4x185 (4x350 mcm)
Maximum external mains fuses [A] <sup>1)</sup>	900	900	900	1500
Estimated power loss at 400 V [W] <sup>2), 3)</sup>	10647	12338	13201	15436
Estimated power loss at 460 V [W] <sup>2), 3)</sup>	9414	11006	12353	14041
Maximum added losses A1 RFI, circuit breaker or disconnect, and contactor [W], (F11 only)	963	1054	1093	1230
Maximum panel options losses [W]	400	400	400	400
Efficiency <sup>3)</sup>	0.98	0.98	0.98	0.98
Output frequency [Hz]	0–590	0–590	0–590	0–590
Control card overtemperature trip [°C (°F)]	85 (185)	85 (185)	85 (185)	85 (185)

**Table 7.5 Electrical Data for Enclosures F10/F11, Mains Supply 6x380–480 V AC**

1) For fuse ratings, see chapter 10.5 Fuses and Circuit Breakers.

2) Typical power loss is at normal conditions and expected to be within ±15% (tolerance relates to variety in voltage and cable conditions). These values are based on a typical motor efficiency (IE/IE3 border line). Lower efficiency motors add to the power loss in the drive. Applies for dimensioning of drive cooling. If the switching frequency is higher than the default setting, the power losses can increase. LCP and typical control card power consumptions are included. For power loss data according to EN 50598-2, refer to [drives.danfoss.com/knowledge-center/energy-efficiency-directive/#/](http://drives.danfoss.com/knowledge-center/energy-efficiency-directive/#/). Options and customer load can add up to 30 W to the losses, though usually a fully loaded control card and options for slots A and B each add only 4 W.

3) Measured using 5 m (16.5 ft) shielded motor cables at rated load and rated frequency. Efficiency measured at nominal current. For energy efficiency class, see chapter 10.12 Efficiency. For part load losses, see [drives.danfoss.com/knowledge-center/energy-efficiency-directive/#/](http://drives.danfoss.com/knowledge-center/energy-efficiency-directive/#/).

VLT® HVAC Drive FC 102	P800	P1000
<b>Normal overload</b> (Normal overload=110% current during 60 s)	<b>NO</b>	<b>NO</b>
Typical shaft output at 400 V [kW]	800	1000
Typical shaft output at 460 V [hp]	1200	1350
Typical shaft output at 480 V [kW]	1000	1100
<b>Enclosure size</b>	<b>F12/F13</b>	<b>F12/F13</b>
<b>Output current (3-phase)</b>		
Continuous (at 400 V) [A]	1460	1720
Intermittent (60 s overload) (at 400 V) [A]	1606	1892
Continuous (at 460/480 V) [A]	1380	1530
Intermittent (60 s overload)(at 460/480 V) [A]	1518	1683
Continuous kVA (at 400 V) [kVA]	1012	1192
Continuous kVA (at 460 V) [kVA]	1100	1219
Continuous kVA (at 480 V) [kVA]	1195	1325
<b>Maximum input current</b>		
Continuous (at 400 V) [A]	1407	1658
Continuous (at 460/480 V) [A]	1330	1474
<b>Maximum number and size of cables per phase</b>		
- Motor [mm <sup>2</sup> (AWG)]	12x150 (12x300 mcm)	12x150 (12x300 mcm)
- Mains [mm <sup>2</sup> (AWG)]	6x120 (6x250 mcm)	6x120 (6x250 mcm)
- Brake [mm <sup>2</sup> (AWG)]	6x185 (6x350 mcm)	6x185 (6x350 mcm)
Maximum external mains fuses [A] <sup>1)</sup>	1500	1500
Estimated power loss at 400 V [W] <sup>2), 3)</sup>	18084	20358
Estimated power loss at 460 V [W] <sup>2), 3)</sup>	17137	17752
Maximum added losses A1 RFI, circuit breaker or disconnect, and contactor [W], (F4 only)	2280	2541
Maximum panel options losses [W]	400	400
Efficiency <sup>3)</sup>	0.98	0.98
Output frequency [Hz]	0–590	0–590
Control card overtemperature trip [°C (°F)]	85 (185)	85 (185)

7

**Table 7.6 Electrical Data for Enclosures F12/F13, Mains Supply 6x380–480 V AC**

1) For fuse ratings, see chapter 10.5 Fuses and Circuit Breakers.

2) Typical power loss is at normal conditions and expected to be within ±15% (tolerance relates to variety in voltage and cable conditions). These values are based on a typical motor efficiency (IE/IE3 border line). Lower efficiency motors add to the power loss in the drive. Applies for dimensioning of drive cooling. If the switching frequency is higher than the default setting, the power losses can increase. LCP and typical control card power consumptions are included. For power loss data according to EN 50598-2, refer to [drives.danfoss.com/knowledge-center/energy-efficiency-directive/#/](http://drives.danfoss.com/knowledge-center/energy-efficiency-directive/#/). Options and customer load can add up to 30 W to the losses, though usually a fully loaded control card and options for slots A and B each add only 4 W.

3) Measured using 5 m (16.5 ft) shielded motor cables at rated load and rated frequency. Efficiency measured at nominal current. For energy efficiency class, see chapter 10.12 Efficiency. For part load losses, see [drives.danfoss.com/knowledge-center/energy-efficiency-directive/#/](http://drives.danfoss.com/knowledge-center/energy-efficiency-directive/#/).

**7.2 Electrical Data, 525–690 V**

VLT® HVAC Drive FC 102	P450	P500	P560	P630
<b>Normal overload</b> (Normal overload=110% current during 60 s)	<b>NO</b>	<b>NO</b>	<b>NO</b>	<b>NO</b>
Typical shaft output at 550 V [kW]	355	400	450	500
Typical shaft output at 575 V [hp]	450	500	600	650
Typical shaft output at 690 V [kW]	450	500	560	630
<b>Enclosure size</b>	<b>E1/E2</b>	<b>E1/E2</b>	<b>E1/E2</b>	<b>E1/E2</b>
<b>Output current (3-phase)</b>				
Continuous (at 550 V) [A]	470	523	596	630
Intermittent (60 s overload) (at 550 V) [A]	517	575	656	693
Continuous (at 575/690 V) [A]	450	500	570	630
Intermittent (60 s overload) (at 575/690 V) [A]	495	550	627	693
Continuous kVA (at 550 V) [kVA]	448	498	568	600
Continuous kVA (at 575 V) [kVA]	448	498	568	627
Continuous kVA (at 690 V) [kVA]	538	598	681	753
<b>Maximum input current</b>				
Continuous (at 550 V) [A]	453	504	574	607
Continuous (at 575 V) [A]	434	482	549	607
Continuous (at 690 V)	434	482	549	607
<b>Maximum number and size of cables per phase</b>				
- Mains, motor, and load share [mm <sup>2</sup> (AWG)]	4x240 (4x500 mcm)	4x240 (4x500 mcm)	4x240 (4x500 mcm)	4x240 (4x500 mcm)
- Brake [mm <sup>2</sup> (AWG)]	2x185 (2x350 mcm)	2x185 (2x350 mcm)	2x185 (2x350 mcm)	2x185 (2x350 mcm)
Maximum external mains fuses [A] <sup>1)</sup>	700	700	900	900
Estimated power loss at 600 V [W] <sup>2), 3)</sup>	5323	6010	7395	8209
Estimated power loss at 690 V [W] <sup>2), 3)</sup>	5529	6239	7653	8495
Efficiency <sup>3)</sup>	0.98	0.98	0.98	0.98
Output frequency [Hz]	0–500	0–500	0–500	0–500
Control card overtemperature trip [°C (°F)]	85 (185)	85 (185)	85 (185)	85 (185)

**Table 7.7 Electrical Data for Enclosures E1/E2, Mains Supply 3x525–690 V AC**

1) For fuse ratings, see chapter 10.5 Fuses and Circuit Breakers.

2) Typical power loss is at normal conditions and expected to be within ±15% (tolerance relates to variety in voltage and cable conditions). These values are based on a typical motor efficiency (IE/IE3 border line). Lower efficiency motors add to the power loss in the drive. Applies for dimensioning of drive cooling. If the switching frequency is higher than the default setting, the power losses can increase. LCP and typical control card power consumptions are included. For power loss data according to EN 50598-2, refer to [drives.danfoss.com/knowledge-center/energy-efficiency-directive/#/](http://drives.danfoss.com/knowledge-center/energy-efficiency-directive/#/). Options and customer load can add up to 30 W to the losses, though usually a fully loaded control card and options for slots A and B each add only 4 W.

3) Measured using 5 m (16.5 ft) shielded motor cables at rated load and rated frequency. Efficiency measured at nominal current. For energy efficiency class, see chapter 10.12 Efficiency. For part load losses, see [drives.danfoss.com/knowledge-center/energy-efficiency-directive/#/](http://drives.danfoss.com/knowledge-center/energy-efficiency-directive/#/).



VLT® HVAC Drive FC 102	P710	P800	P900
<b>Normal overload</b> (Normal overload=110% current during 60 s)	<b>NO</b>	<b>NO</b>	<b>NO</b>
Typical shaft output at 550 V [kW]	560	670	750
Typical shaft output at 575 V [hp]	750	950	1050
Typical shaft output at 690 V [kW]	710	800	900
<b>Enclosure size</b>	<b>F1/F3</b>	<b>F1/F3</b>	<b>F1/F3</b>
<b>Output current (3-phase)</b>			
Continuous (at 550 V) [A]	763	889	988
Intermittent (60 s overload) (at 550 V) [A]	839	978	1087
Continuous (at 575/690 V) [A]	730	850	945
Intermittent (60 s overload) (at 575/690 V) [A]	803	935	1040
Continuous kVA (at 550 V) [kVA]	727	847	941
Continuous kVA (at 575 V) [kVA]	727	847	941
Continuous kVA (at 690 V) [kVA]	872	1016	1129
<b>Maximum input current</b>			
Continuous (at 550 V) [A]	735	857	952
Continuous (at 575 V) [A]	704	819	911
Continuous (at 690 V) [A]	704	819	911
<b>Maximum number and size of cables per phase</b>			
- Motor [mm <sup>2</sup> (AWG)]	8x150 (8x300 mcm)	8x150 (8x300 mcm)	8x150 (8x300 mcm)
- Mains [mm <sup>2</sup> (AWG)] (F1)	8x240 (8x500 mcm)	8x240 (8x500 mcm)	8x240 (8x500 mcm)
- Mains [mm <sup>2</sup> (AWG)] (F3)	8x456 (4x900 mcm)	8x456 (4x900 mcm)	8x456 (4x900 mcm)
- Load share [mm <sup>2</sup> (AWG)]	4x120 (4x250 mcm)	4x120 (4x250 mcm)	4x120 (4x250 mcm)
- Brake [mm <sup>2</sup> (AWG)]	4x185 (4x350 mcm)	4x185 (4x350 mcm)	4x185 (4x350 mcm)
Maximum external mains fuses [A] <sup>1)</sup>	1600	1600	1600
Estimated power loss at 600 V [W] <sup>2), 3)</sup>	9500	10872	12316
Estimated power loss at 690 V [W] <sup>2), 3)</sup>	9863	11304	12798
Maximum added losses for circuit breaker or disconnect and contactor [W], (F3 only)	427	532	615
Maximum panel options losses [W]	400	400	400
Efficiency <sup>3)</sup>	0.98	0.98	0.98
Output frequency [Hz]	0–500	0–500	0–500
Control card overtemperature trip [°C (°F)]	85 (185)	85 (185)	85 (185)

7

**Table 7.8 Electrical Data for Enclosures F1/F3, Mains Supply 3x525–690 V AC**

1) For fuse ratings, see chapter 10.5 Fuses and Circuit Breakers.

2) Typical power loss is at normal conditions and expected to be within ±15% (tolerance relates to variety in voltage and cable conditions). These values are based on a typical motor efficiency (IE/IE3 border line). Lower efficiency motors add to the power loss in the drive. Applies for dimensioning of drive cooling. If the switching frequency is higher than the default setting, the power losses can increase. LCP and typical control card power consumptions are included. For power loss data according to EN 50598-2, refer to [drives.danfoss.com/knowledge-center/energy-efficiency-directive/#/](http://drives.danfoss.com/knowledge-center/energy-efficiency-directive/#/). Options and customer load can add up to 30 W to the losses, though usually a fully loaded control card and options for slots A and B each add only 4 W.

3) Measured using 5 m (16.5 ft) shielded motor cables at rated load and rated frequency. Efficiency measured at nominal current. For energy efficiency class, see chapter 10.12 Efficiency. For part load losses, see [drives.danfoss.com/knowledge-center/energy-efficiency-directive/#/](http://drives.danfoss.com/knowledge-center/energy-efficiency-directive/#/).

VLT® HVAC Drive FC 102	P1M0	P1M2	P1M4
<b>Normal overload</b> (Normal overload=110% current during 60 s)	<b>NO</b>	<b>NO</b>	<b>NO</b>
Typical shaft output at 550 V [kW]	850	1000	1100
Typical shaft output at 575 V [hp]	1150	1350	1550
Typical shaft output at 690 V [kW]	1000	1200	1400
<b>Enclosure size</b>	<b>F2/F4</b>	<b>F2/F4</b>	<b>F2/F4</b>
<b>Output current (3-phase)</b>			
Continuous (at 550 V) [A]	1108	1317	1479
Intermittent (60 s overload) (at 550 V) [A]	1219	1449	1627
Continuous (at 575/690 V) [A]	1060	1260	1415
Intermittent (60 s overload) (at 575/690 V) [A]	1166	1386	1557
Continuous kVA (at 550 V) [kVA]	1056	1255	1409
Continuous kVA (at 575 V) [kVA]	1056	1255	1409
Continuous kVA (at 690 V) [kVA]	1267	1506	1691
<b>Maximum input current</b>			
Continuous (at 550 V) [A]	1068	1269	1425
Continuous (at 575 V) [A]	1022	1214	1364
Continuous (at 690 V) [A]	1022	1214	1364
<b>Maximum number and size of cables per phase</b>			
- Motor [mm <sup>2</sup> (AWG)]	12x150 (12x300 mcm)	12x150 (12x300 mcm)	12x150 (12x300 mcm)
- Mains [mm <sup>2</sup> (AWG)] (F2)	8x240 (8x500 mcm)	8x240 (8x500 mcm)	8x240 (8x500 mcm)
- Mains [mm <sup>2</sup> (AWG)] (F4)	8x456 (8x900 mcm)	8x456 (8x900 mcm)	8x456 (8x900 mcm)
- Load share [mm <sup>2</sup> (AWG)]	4x120 (4x250 mcm)	4x120 (4x250 mcm)	4x120 (4x250 mcm)
- Brake [mm <sup>2</sup> (AWG)]	6x185 (6x350 mcm)	6x185 (6x350 mcm)	6x185 (6x350 mcm)
Maximum external mains fuses [A] <sup>1)</sup>	1600	2000	2500
Estimated power loss at 600 V [W] <sup>2), 3)</sup>	13731	16190	18536
Estimated power loss at 690 V [W] <sup>2), 3)</sup>	14250	16821	19247
Maximum added losses for circuit breaker or disconnect and contactor [W], (F4 only)	665	863	1044
Maximum panel options losses [W]	400	400	400
Efficiency <sup>3)</sup>	0.98	0.98	0.98
Output frequency [Hz]	0–500	0–500	0–500
Control card overtemperature trip [°C (°F)]	85 (185)	85 (185)	85 (185)

**Table 7.9 Electrical Data for Enclosures F2/F4, Mains Supply 3x525–690 V AC**

1) For fuse ratings, see chapter 10.5 Fuses and Circuit Breakers.

2) Typical power loss is at normal conditions and expected to be within ±15% (tolerance relates to variety in voltage and cable conditions). These values are based on a typical motor efficiency (IE/IE3 border line). Lower efficiency motors add to the power loss in the drive. Applies for dimensioning of drive cooling. If the switching frequency is higher than the default setting, the power losses can increase. LCP and typical control card power consumptions are included. For power loss data according to EN 50598-2, refer to [drives.danfoss.com/knowledge-center/energy-efficiency-directive/#/](http://drives.danfoss.com/knowledge-center/energy-efficiency-directive/#/). Options and customer load can add up to 30 W to the losses, though usually a fully loaded control card and options for slots A and B each add only 4 W.

3) Measured using 5 m (16.5 ft) shielded motor cables at rated load and rated frequency. Efficiency measured at nominal current. For energy efficiency class, see chapter 10.12 Efficiency. For part load losses, see [drives.danfoss.com/knowledge-center/energy-efficiency-directive/#/](http://drives.danfoss.com/knowledge-center/energy-efficiency-directive/#/).

VLT® HVAC Drive FC 102	P450	P500	P560	P630
<b>Normal overload</b> (Normal overload=110% current during 60 s)	<b>NO</b>	<b>NO</b>	<b>NO</b>	<b>NO</b>
Typical shaft output at 550 V [kW]	355	400	450	500
Typical shaft output at 575 V [hp]	450	500	600	650
Typical shaft output at 690 V [kW]	450	500	560	630
<b>Enclosure size</b>	<b>F8/F9</b>	<b>F8/F9</b>	<b>F8/F9</b>	<b>F8/F9</b>
<b>Output current (3-phase)</b>				
Continuous (at 550 V) [A]	470	523	596	630
Intermittent (60 s overload) (at 550 V) [A]	517	575	656	693
Continuous (at 575/690 V) [A]	450	500	570	630
Intermittent (60 s overload) (at 575/690 V) [A]	495	550	627	693
Continuous kVA (at 550 V) [kVA]	448	498	568	600
Continuous kVA (at 575 V) [kVA]	448	498	568	627
Continuous kVA (at 690 V) [kVA]	538	598	681	753
<b>Maximum input current</b>				
Continuous (at 550 V) [A]	453	504	574	607
Continuous (at 575 V) [A]	434	482	549	607
Continuous (at 690 V)	434	482	549	607
<b>Maximum number and size of cables per phase</b>				
- Motor [mm <sup>2</sup> (AWG)]	4x240 (4x500 mcm)	4x240 (4x500 mcm)	4x240 (4x500 mcm)	4x240 (4x500 mcm)
- Mains [mm <sup>2</sup> (AWG)]	4x85 (4x3/0 mcm)	4x85 (4x3/0 mcm)	4x85 (4x3/0 mcm)	4x85 (4x3/0 mcm)
- Brake [mm <sup>2</sup> (AWG)]	2x185 (2x350 mcm)	2x185 (2x350 mcm)	2x185 (2x350 mcm)	2x185 (2x350 mcm)
Maximum external mains fuses [A] <sup>1)</sup>	630	630	630	630
Estimated power loss at 600 V [W] <sup>2), 3)</sup>	5323	6010	7395	8209
Estimated power loss at 690 V [W] <sup>2), 3)</sup>	5529	6239	7653	8495
Efficiency <sup>3)</sup>	0.98	0.98	0.98	0.98
Output frequency [Hz]	0–500	0–500	0–500	0–500
Control card overtemperature trip [°C (°F)]	85 (185)	85 (185)	85 (185)	85 (185)

**Table 7.10 Electrical Data for Enclosures F8/F9, Mains Supply 6x525–690 V AC**

1) For fuse ratings, see chapter 10.5 Fuses and Circuit Breakers.

2) Typical power loss is at normal conditions and expected to be within ±15% (tolerance relates to variety in voltage and cable conditions). These values are based on a typical motor efficiency (IE/IE3 border line). Lower efficiency motors add to the power loss in the drive. Applies for dimensioning of drive cooling. If the switching frequency is higher than the default setting, the power losses can increase. LCP and typical control card power consumptions are included. For power loss data according to EN 50598-2, refer to [drives.danfoss.com/knowledge-center/energy-efficiency-directive/#/](http://drives.danfoss.com/knowledge-center/energy-efficiency-directive/#/). Options and customer load can add up to 30 W to the losses, though usually a fully loaded control card and options for slots A and B each add only 4 W.

3) Measured using 5 m (16.5 ft) shielded motor cables at rated load and rated frequency. Efficiency measured at nominal current. For energy efficiency class, see chapter 10.12 Efficiency. For part load losses, see [drives.danfoss.com/knowledge-center/energy-efficiency-directive/#/](http://drives.danfoss.com/knowledge-center/energy-efficiency-directive/#/).

VLT® HVAC Drive FC 102	P710	P800	P900
<b>Normal overload</b> (Normal overload=110% current during 60 s)	<b>NO</b>	<b>NO</b>	<b>NO</b>
Typical shaft output at 550 V [kW]	560	670	750
Typical shaft output at 575 V [hp]	750	950	1050
Typical shaft output at 690 V [kW]	710	800	900
<b>Enclosure size</b>	<b>F10/F11</b>	<b>F10/F11</b>	<b>F10/F11</b>
<b>Output current (3-phase)</b>			
Continuous (at 550 V) [A]	763	889	988
Intermittent (60 s overload) (at 550 V) [A]	839	978	1087
Continuous (at 575/690 V) [A]	730	850	945
Intermittent (60 s overload) (at 575/690 V) [A]	803	935	1040
Continuous kVA (at 550 V) [kVA]	727	847	941
Continuous kVA (at 575 V) [kVA]	727	847	941
Continuous kVA (at 690 V) [kVA]	872	1016	1129
<b>Maximum input current</b>			
Continuous (at 550 V) [A]	735	857	952
Continuous (at 575 V) [A]	704	819	911
Continuous (at 690 V) [A]	704	819	911
<b>Maximum number and size of cables per phase</b>			
- Motor [mm <sup>2</sup> (AWG)]	8x150 (8x300 mcm)	8x150 (8x300 mcm)	8x150 (8x300 mcm)
- Mains [mm <sup>2</sup> (AWG)]	6x120 (4x900 mcm)	6x120 (4x900 mcm)	6x120 (4x900 mcm)
- Brake [mm <sup>2</sup> (AWG)]	4x185 (4x350 mcm)	4x185 (4x350 mcm)	4x185 (4x350 mcm)
Maximum external mains fuses [A] <sup>1)</sup>	900	900	900
Estimated power loss at 600 V [W] <sup>2), 3)</sup>	9500	10872	12316
Estimated power loss at 690 V [W] <sup>2), 3)</sup>	9863	11304	12798
Maximum added losses for circuit breaker or disconnect and contactor [W], (F11 only)	427	532	615
Maximum panel options losses [W]	400	400	400
Efficiency <sup>3)</sup>	0.98	0.98	0.98
Output frequency [Hz]	0–500	0–500	0–500
Control card overtemperature trip [°C (°F)]	85 (185)	85 (185)	85 (185)

**Table 7.11 Electrical Data for Enclosures F10/F11, Mains Supply 6x525–690 V AC**

1) For fuse ratings, see chapter 10.5 Fuses and Circuit Breakers.

2) Typical power loss is at normal conditions and expected to be within ±15% (tolerance relates to variety in voltage and cable conditions). These values are based on a typical motor efficiency (IE/IE3 border line). Lower efficiency motors add to the power loss in the drive. Applies for dimensioning of drive cooling. If the switching frequency is higher than the default setting, the power losses can increase. LCP and typical control card power consumptions are included. For power loss data according to EN 50598-2, refer to [drives.danfoss.com/knowledge-center/energy-efficiency-directive/#/](http://drives.danfoss.com/knowledge-center/energy-efficiency-directive/#/). Options and customer load can add up to 30 W to the losses, though usually a fully loaded control card and options for slots A and B each add only 4 W.

3) Measured using 5 m (16.5 ft) shielded motor cables at rated load and rated frequency. Efficiency measured at nominal current. For energy efficiency class, see chapter 10.12 Efficiency. For part load losses, see [drives.danfoss.com/knowledge-center/energy-efficiency-directive/#/](http://drives.danfoss.com/knowledge-center/energy-efficiency-directive/#/).

VLT® HVAC Drive FC 102	P1M0	P1M2	P1M4
<b>Normal overload</b> (Normal overload=110% current during 60 s)	<b>NO</b>	<b>NO</b>	<b>NO</b>
Typical shaft output at 550 V [kW]	850	1000	1100
Typical shaft output at 575 V [hp]	1150	1350	1550
Typical shaft output at 690 V [kW]	1000	1200	1400
<b>Enclosure size</b>	<b>F12/F13</b>	<b>F12/F13</b>	<b>F12/F13</b>
<b>Output current (3-phase)</b>			
Continuous (at 550 V) [A]	1108	1317	1479
Intermittent (60 s overload) (at 550 V) [A]	1219	1449	1627
Continuous (at 575/690 V) [A]	1060	1260	1415
Intermittent (60 s overload) (at 575/690 V) [A]	1166	1386	1557
Continuous kVA (at 550 V) [kVA]	1056	1255	1409
Continuous kVA (at 575 V) [kVA]	1056	1255	1409
Continuous kVA (at 690 V) [kVA]	1267	1506	1691
<b>Maximum input current</b>			
Continuous (at 550 V) [A]	1068	1269	1425
Continuous (at 575 V) [A]	1022	1214	1364
Continuous (at 690 V) [A]	1022	1214	1364
<b>Maximum number and size of cables per phase</b>			
- Motor [mm <sup>2</sup> (AWG)]	12x150 (12x300 mcm)	12x150 (12x300 mcm)	12x150 (12x300 mcm)
- Mains [mm <sup>2</sup> (AWG)] (F12)	8x240 (8x500 mcm)	8x240 (8x500 mcm)	8x240 (8x500 mcm)
- Mains [mm <sup>2</sup> (AWG)] (F13)	8x456 (8x900 mcm)	8x456 (8x900 mcm)	8x456 (8x900 mcm)
- Brake [mm <sup>2</sup> (AWG)]	6x185 (6x350 mcm)	6x185 (6x350 mcm)	6x185 (6x350 mcm)
Maximum external mains fuses [A] <sup>1)</sup>	1600	2000	2500
Estimated power loss at 600 V [W] <sup>2), 3)</sup>	13731	16190	18536
Estimated power loss at 690 V [W] <sup>2), 3)</sup>	14250	16821	19247
Maximum added losses for circuit breaker or disconnect and contactor [W], (F13 only)	665	863	1044
Maximum panel options losses [W]	400	400	400
Efficiency <sup>3)</sup>	0.98	0.98	0.98
Output frequency [Hz]	0-500	0-500	0-500
Control card overtemperature trip [°C (°F)]	85 (185)	85 (185)	85 (185)

**Table 7.12 Electrical Data for Enclosures F12/F13, Mains Supply 6x525–690 V AC**

1) For fuse ratings, see chapter 10.5 Fuses and Circuit Breakers.

2) Typical power loss is at normal conditions and expected to be within ±15% (tolerance relates to variety in voltage and cable conditions). These values are based on a typical motor efficiency (IE/IE3 border line). Lower efficiency motors add to the power loss in the drive. Applies for dimensioning of drive cooling. If the switching frequency is higher than the default setting, the power losses can increase. LCP and typical control card power consumptions are included. For power loss data according to EN 50598-2, refer to [drives.danfoss.com/knowledge-center/energy-efficiency-directive/#/](http://drives.danfoss.com/knowledge-center/energy-efficiency-directive/#/). Options and customer load can add up to 30 W to the losses, though usually a fully loaded control card and options for slots A and B each add only 4 W.

3) Measured using 5 m (16.5 ft) shielded motor cables at rated load and rated frequency. Efficiency measured at nominal current. For energy efficiency class, see chapter 10.12 Efficiency. For part load losses, see [drives.danfoss.com/knowledge-center/energy-efficiency-directive/#/](http://drives.danfoss.com/knowledge-center/energy-efficiency-directive/#/).

### 7.3 Mains Supply

**Mains supply**

Supply terminals (6-pulse)	L1, L2, L3
Supply terminals (12-pulse)	L1-1, L2-1, L3-1, L1-2, L2-2, L3-2
Supply voltage	380–480 V ±10%, 525–690 V ±10%

**Mains voltage low/mains voltage drop-out:**

During low mains voltage or a mains drop-out, the drive continues until the DC-link voltage drops below the minimum stop level, which corresponds typically to 15% below the lowest rated supply voltage of the drive. Power-up and full torque cannot be expected at mains voltage lower than 10% below the lowest rated supply voltage of the drive.

Supply frequency	50/60 Hz ±5%
Maximum imbalance temporary between mains phases	3.0% of rated supply voltage <sup>1)</sup>
True power factor ( $\lambda$ )	≥0.9 nominal at rated load
Displacement power factor ( $\cos \Phi$ ) near unity	(>0.98)
Switching on input supply L1, L2, L3 (power ups)	Maximum 1 time/2 minute
Environment according to EN60664-1	Overvoltage category III/pollution degree 2

The drive is suitable for use on a circuit capable of delivering up to 100 kA short-circuit current rating (SCCR) at 480/600 V.

1) Calculations based on UL/IEC61800-3.

**7**

### 7.4 Motor Output and Motor Data

**Motor output (U, V, W)**

Output voltage	0–100% of supply voltage
Output frequency	0–590 Hz <sup>1)</sup>
Switching on output	Unlimited
Ramp times	0.01–3600 s

1) Dependent on voltage and power.

**Torque characteristics**

Starting torque (constant torque)	Maximum 150% for 60 s <sup>1), 2)</sup>
Overload torque (constant torque)	Maximum 150% for 60 s <sup>1), 2)</sup>

1) Percentage relates to the nominal current of the drive.

2) Once every 10 minutes.

### 7.5 Ambient Conditions

**Environment**

E1/F1/F2/F3/F4/F8/F9/F10/F11/F12/F13 enclosures	IP21/Type 1, IP54/Type 12
E2 enclosure	IP00/Chassis
Vibration test	1.0 g
Relative humidity	5–95% (IEC 721-3-3; Class 3K3 (non-condensing) during operation)
Aggressive environment (IEC 60068-2-43) H <sub>2</sub> S test	Class Kd
Aggressive gases (IEC 60721-3-3)	Class 3C3
Test method according to IEC 60068-2-43	H2S (10 days)
Ambient temperature (at SFAVM switching mode)	
- with derating	Maximum 55 °C (131 °F) <sup>1)</sup>
- with full output power of typical EFF2 motors (up to 90% output current)	Maximum 50 °C (122 °F) <sup>1)</sup>
- at full continuous FC output current	Maximum 45 °C (113 °F) <sup>1)</sup>
Minimum ambient temperature during full-scale operation	0 °C (32 °F)
Minimum ambient temperature at reduced performance	-10 °C (14 °F)
Temperature during storage/transport	-25 to +65/70 °C (13 to 149/158 °F)
Maximum altitude above sea level without derating	1000 m (3281 ft)
Maximum altitude above sea level with derating	3000 m (9842 ft)

1) For more information on derating, see chapter 9.6 Derating.

EMC standards, Emission	EN 61800-3
EMC standards, Immunity	EN 61800-3
Energy efficiency class <sup>1)</sup>	IE2

1) Determined according to EN 50598-2 at:

- Rated load.
- 90% rated frequency.
- Switching frequency factory setting.
- Switching pattern factory setting.

## 7.6 Cable Specifications

Cable lengths and cross-sections for control cables

Maximum motor cable length, shielded	150 m (492 ft)
Maximum motor cable length, unshielded	300 m (984 ft)
Maximum cross-section to motor, mains, load sharing, and brake	See chapter 7 Specifications <sup>1)</sup>
Maximum cross-section to control terminals, rigid wire	1.5 mm <sup>2</sup> /16 AWG (2x0.75 mm <sup>2</sup> )
Maximum cross-section to control terminals, flexible cable	1 mm <sup>2</sup> /18 AWG
Maximum cross-section to control terminals, cable with enclosed core	0.5 mm <sup>2</sup> /20 AWG
Minimum cross-section to control terminals	0.25 mm <sup>2</sup> /23 AWG

1) For power cables, see electrical data in chapter 7.1 Electrical Data, 380–480 V and chapter 7.2 Electrical Data, 525–690 V.

## 7.7 Control Input/Output and Control Data

Digital inputs

Programmable digital inputs	4 (6)
Terminal number	18, 19, 27 <sup>1)</sup> , 29 <sup>1)</sup> , 32, 33
Logic	PNP or NPN
Voltage level	0–24 V DC
Voltage level, logic 0 PNP	<5 V DC
Voltage level, logic 1 PNP	>10 V DC
Voltage level, logic 0 NPN	>19 V DC
Voltage level, logic 1 NPN	<14 V DC
Maximum voltage on input	28 V DC
Input resistance, R <sub>i</sub>	Approximately 4 kΩ

All digital inputs are galvanically isolated from the supply voltage (PELV) and other high-voltage terminals.

1) Terminals 27 and 29 can also be programmed as outputs.

Analog inputs

Number of analog inputs	2
Terminal number	53, 54
Modes	Voltage or current
Mode select	Switches A53 and A54
Voltage mode	Switch A53/A54=(U)
Voltage level	-10 V to +10 V (scaleable)
Input resistance, R <sub>i</sub>	Approximately 10 kΩ
Maximum voltage	±20 V
Current mode	Switch A53/A54=(I)
Current level	0/4 to 20 mA (scaleable)
Input resistance, R <sub>i</sub>	Approximately 200 Ω
Maximum current	30 mA
Resolution for analog inputs	10 bit (+ sign)
Accuracy of analog inputs	Maximum error 0.5% of full scale
Bandwidth	100 Hz

The analog inputs are galvanically isolated from the supply voltage (PELV) and other high-voltage terminals.

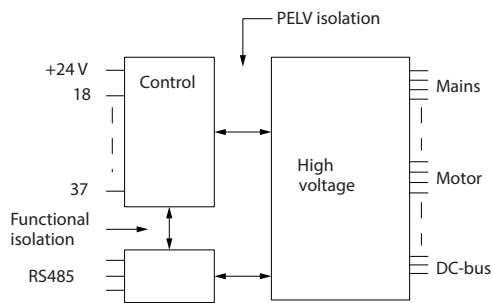

Illustration 7.1 PELV Isolation

Pulse inputs

Programmable pulse inputs	2
Terminal number pulse	29, 33
Maximum frequency at terminal 29, 33 (push-pull driven)	110 kHz
Maximum frequency at terminal 29, 33 (open collector)	5 kHz
Minimum frequency at terminal 29, 33	4 Hz
Voltage level	See <i>Digital Inputs</i> in chapter 7.7 <i>Control Input/Output and Control Data</i>
Maximum voltage on input	28 V DC
Input resistance, $R_i$	Approximately 4 k $\Omega$
Pulse input accuracy (0.1–1 kHz)	Maximum error: 0.1% of full scale

Analog output

Number of programmable analog outputs	1
Terminal number	42
Current range at analog output	0/4–20 mA
Maximum resistor load to common at analog output	500 $\Omega$
Accuracy on analog output	Maximum error: 0.8% of full scale
Resolution on analog output	8 bit

*The analog output is galvanically isolated from the supply voltage (PELV) and other high-voltage terminals.*

Control card, RS485 serial communication

Terminal number	68 (P, TX+, RX+), 69 (N, TX-, RX-)
Terminal number 61	Common for terminals 68 and 69

*The RS485 serial communication circuit is functionally separated from other central circuits and galvanically isolated from the supply voltage (PELV).*

Digital output

Programmable digital/pulse outputs	2
Terminal number	27, 29 <sup>1)</sup>
Voltage level at digital/frequency output	0–24 V
Maximum output current (sink or source)	40 mA
Maximum load at frequency output	1 k $\Omega$
Maximum capacitive load at frequency output	10 nF
Minimum output frequency at frequency output	0 Hz
Maximum output frequency at frequency output	32 kHz
Accuracy of frequency output	Maximum error: 0.1% of full scale
Resolution of frequency outputs	12 bit

*1) Terminals 27 and 29 can also be programmed as inputs.*

*The digital output is galvanically isolated from the supply voltage (PELV) and other high-voltage terminals.*



## Control card, 24 V DC output

Terminal number	12, 13
Maximum load	200 mA

The 24 V DC supply is galvanically isolated from the supply voltage (PELV), but has the same potential as the analog and digital inputs and outputs.

## Relay outputs

Programmable relay outputs	2
Maximum cross-section to relay terminals	2.5 mm <sup>2</sup> (12 AWG)
Minimum cross-section to relay terminals	0.2 mm <sup>2</sup> (30 AWG)
Length of stripped wire	8 mm (0.3 in)
<b>Relay 01 terminal number</b>	1–3 (break), 1–2 (make)
Maximum terminal load (AC-1) <sup>1)</sup> on 1–2 (NO) (Resistive load) <sup>2), 3)</sup>	400 V AC, 2 A
Maximum terminal load (AC-15) <sup>1)</sup> on 1–2 (NO) (Inductive load @ cosφ 0.4)	240 V AC, 0.2 A
Maximum terminal load (DC-1) <sup>1)</sup> on 1–2 (NO) (Resistive load)	80 V DC, 2 A
Maximum terminal load (DC-13) <sup>1)</sup> on 1–2 (NO) (Inductive load)	24 V DC, 0.1 A
Maximum terminal load (AC-1) <sup>1)</sup> on 1–3 (NC) (Resistive load)	240 V AC, 2 A
Maximum terminal load (AC-15) <sup>1)</sup> on 1–3 (NC) (Inductive load @ cosφ 0.4)	240 V AC, 0.2 A
Maximum terminal load (DC-1) <sup>1)</sup> on 1–3 (NC) (Resistive load)	50 V DC, 2 A
Maximum terminal load (DC-13) <sup>1)</sup> on 1–3 (NC) (Inductive load)	24 V DC, 0.1 A
Minimum terminal load on 1–3 (NC), 1–2 (NO)	24 V DC 10 mA, 24 V AC 2 mA
Environment according to EN 60664-1	Overvoltage category III/pollution degree 2
<b>Relay 02 terminal number</b>	4–6 (break), 4–5 (make)
Maximum terminal load (AC-1) <sup>1)</sup> on 4–5 (NO) (Resistive load) <sup>2), 3)</sup>	400 V AC, 2 A
Maximum terminal load (AC-15) <sup>1)</sup> on 4–5 (NO) (Inductive load @ cosφ 0.4)	240 V AC, 0.2 A
Maximum terminal load (DC-1) <sup>1)</sup> on 4–5 (NO) (Resistive load)	80 V DC, 2 A
Maximum terminal load (DC-13) <sup>1)</sup> on 4–5 (NO) (Inductive load)	24 V DC, 0.1 A
Maximum terminal load (AC-1) <sup>1)</sup> on 4–6 (NC) (Resistive load)	240 V AC, 2 A
Maximum terminal load (AC-15) <sup>1)</sup> on 4–6 (NC) (Inductive load @ cosφ 0.4)	240 V AC, 0.2 A
Maximum terminal load (DC-1) <sup>1)</sup> on 4–6 (NC) (Resistive load)	50 V DC, 2 A
Maximum terminal load (DC-13) <sup>1)</sup> on 4–6 (NC) (Inductive load)	24 V DC, 0.1 A
Minimum terminal load on 4–6 (NC), 4–5 (NO)	24 V DC 10 mA, 24 V AC 2 mA
Environment according to EN 60664-1	Overvoltage category III/pollution degree 2

The relay contacts are galvanically isolated from the rest of the circuit by reinforced isolation (PELV).

1) IEC 60947 part 4 and 5.

2) Overvoltage Category II.

3) UL applications 300 V AC 2 A.

## Control card, +10 V DC output

Terminal number	50
Output voltage	10.5 V ±0.5 V
Maximum load	25 mA

The 10 V DC supply is galvanically isolated from the supply voltage (PELV) and other high-voltage terminals.

## Control characteristics

Resolution of output frequency at 0–1000 Hz	±0.003 Hz
System response time (terminals 18, 19, 27, 29, 32, 33)	≤2 m/s
Speed control range (open loop)	1:100 of synchronous speed
Speed accuracy (open loop)	30–4000 RPM: Maximum error of ±8 RPM

All control characteristics are based on a 4-pole asynchronous motor.

**Control card performance**

Scan interval	5 M/S
---------------	-------

**Control card, USB serial communication**

USB standard	1.1 (full speed)
--------------	------------------

USB plug	USB type B device plug
----------	------------------------

**NOTICE**

Connection to PC is carried out via a standard host/device USB cable.

The USB connection is galvanically isolated from the supply voltage (PELV) and other high-voltage terminals.

The USB connection is not galvanically isolated from ground. Use only isolated laptop/PC as connection to the USB connector on the drive or an isolated USB cable/converter.

## 7.8 Enclosure Weights

Enclosure	380–480/500 V	525–690 V
E1	270–313 kg (595–690 lb)	263–313 kg (580–690 lb)
E2	234–277 kg (516–611 lb)	221–277 kg (487–611 lb)

Table 7.13 Enclosure E1–E2 Weights, kg (lb)

Enclosure	380–480/500 V	525–690 V
F1	1017 kg (2242.1 lb)	1017 kg (2242.1 lb)
F2	1260 kg (2777.9 lb)	1260 kg (2777.9 lb)
F3	1318 kg (2905.7 lb)	1318 kg (2905.7 lb)
F4	1561 kg (3441.5 lb)	1561 kg (3441.5 lb)
F8	447 kg (985.5 lb)	447 kg (985.5 lb)
F9	669 kg (1474.9 lb)	669 kg (1474.9 lb)
F10	893 kg (1968.8 lb)	893 kg (1968.8 lb)
F11	1116 kg (2460.4 lb)	1116 kg (2460.4 lb)
F12	1037 kg (2286.4 lb)	1037 kg (2286.4 lb)
F13	1259 kg (2775.7 lb)	1259 kg (2775.7 lb)

Table 7.14 Enclosure F1–F13 Weights, kg (lb)

7.9 Airflow for Enclosures E1–E2 and F1–F13

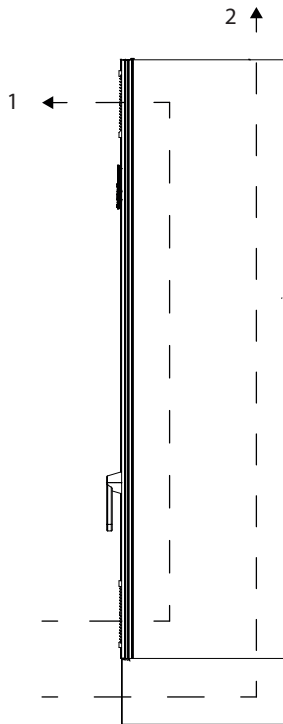

e30bg051.10

1	Front channel airflow, 340 m <sup>3</sup> /hr (200 cfm)
2	Back-channel airflow, 1105 m <sup>3</sup> /hr (650 cfm) or 1444 m <sup>3</sup> /hr (850 cfm)

Illustration 7.2 Airflow for Enclosure E1

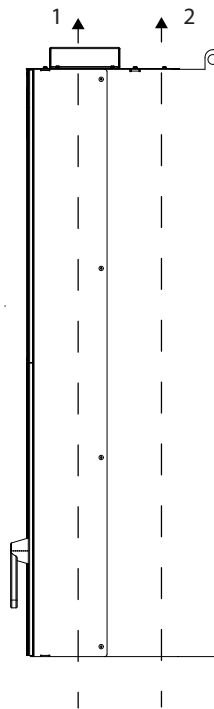

e30bg052.10

1	Front channel airflow, 255 m <sup>3</sup> /hr (150 cfm)
2	Back-channel airflow, 1105 m <sup>3</sup> /hr (650 cfm) or 1444 m <sup>3</sup> /hr (850 cfm)

Illustration 7.3 Airflow for Enclosure E2

7

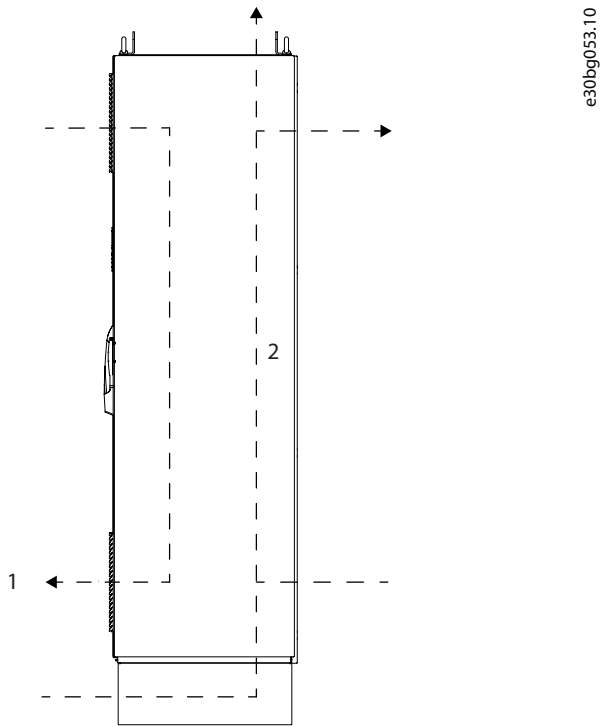

1	Front channel airflow - IP21/Type 1, 700 m <sup>3</sup> /hr (412 cfm) - IP54/Type 12, 525 m <sup>3</sup> /hr (309 cfm)
2	Back-channel airflow, 985 m <sup>3</sup> /hr (580 cfm)

Illustration 7.4 Airflow for Enclosure F1-13

## 8 Exterior and Terminal Dimensions

### 8.1 E1 Exterior and Terminal Dimensions

#### 8.1.1 E1 Exterior Dimensions

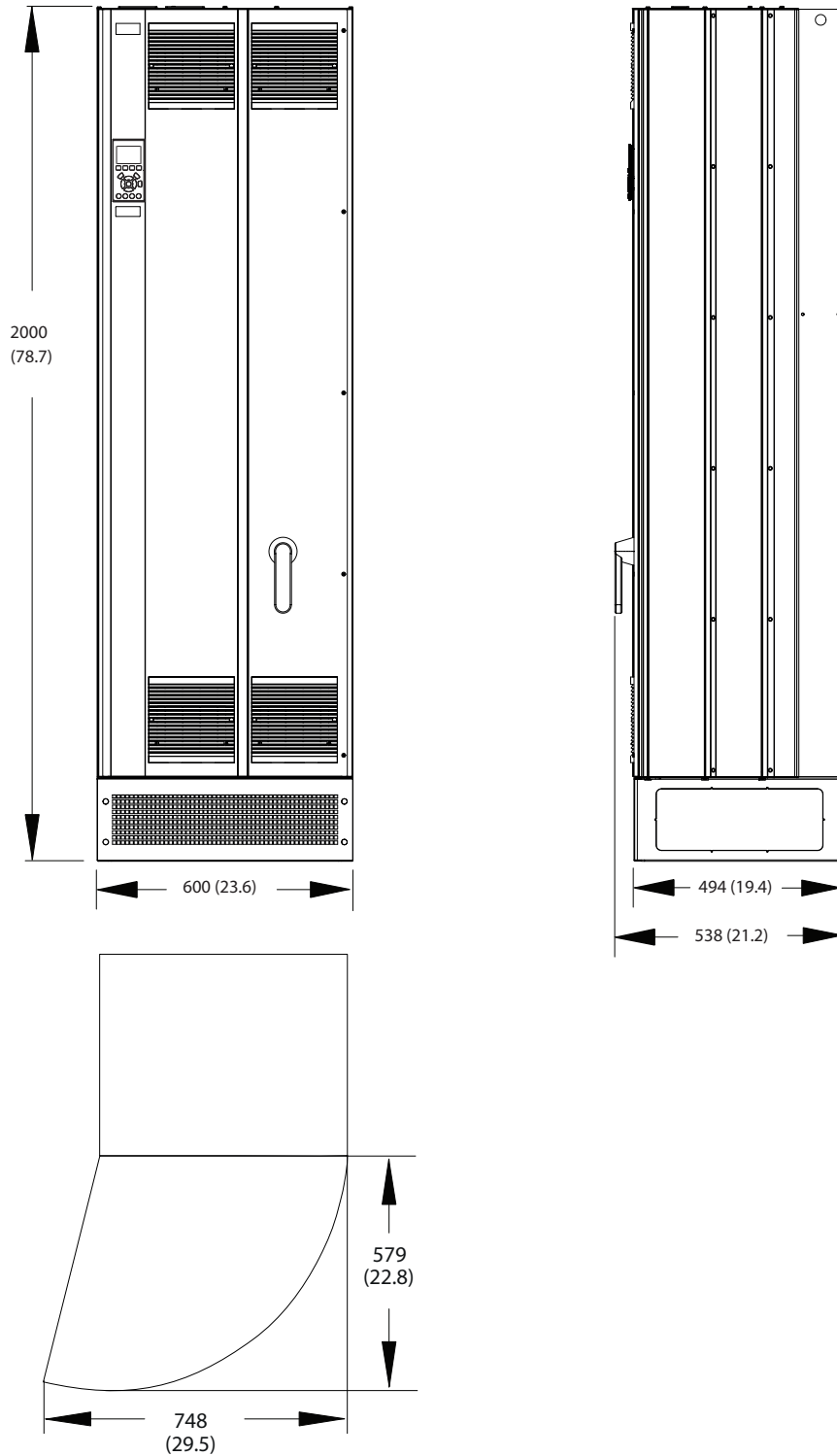

130BF328.10

Illustration 8.1 Front, Side, and Door Clearance Dimensions for E1

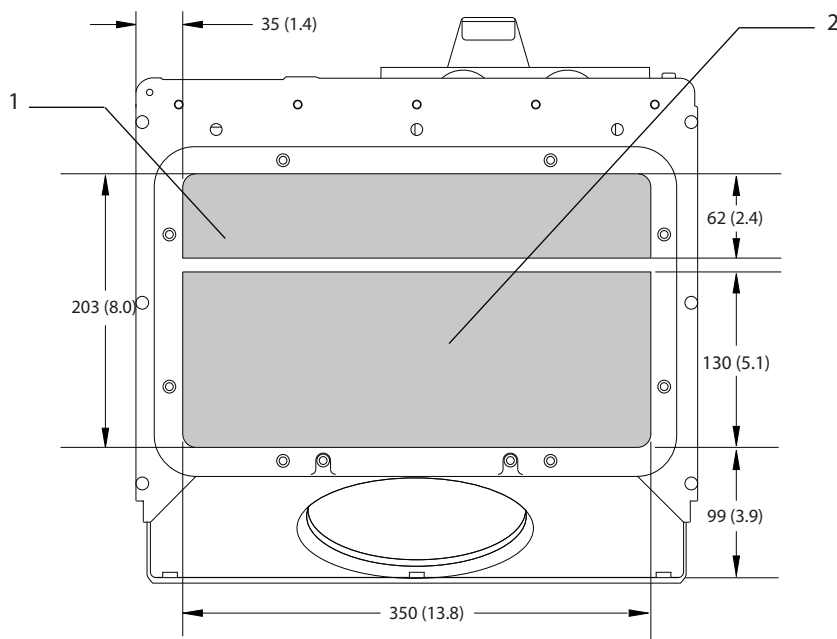

130BF611.10

8

1	Mains side	2	Motor side
---	------------	---	------------

Illustration 8.2 Gland Plate Dimensions for E1/E2

### 8.1.2 E1 Terminal Dimensions

Power cables are heavy and hard to bend. To ensure easy installation of the cables, consider the optimum placement of the drive. Each terminal allows up to 4 cables with cable lugs or a standard box lug. Ground is connected to a relevant termination point in the drive.

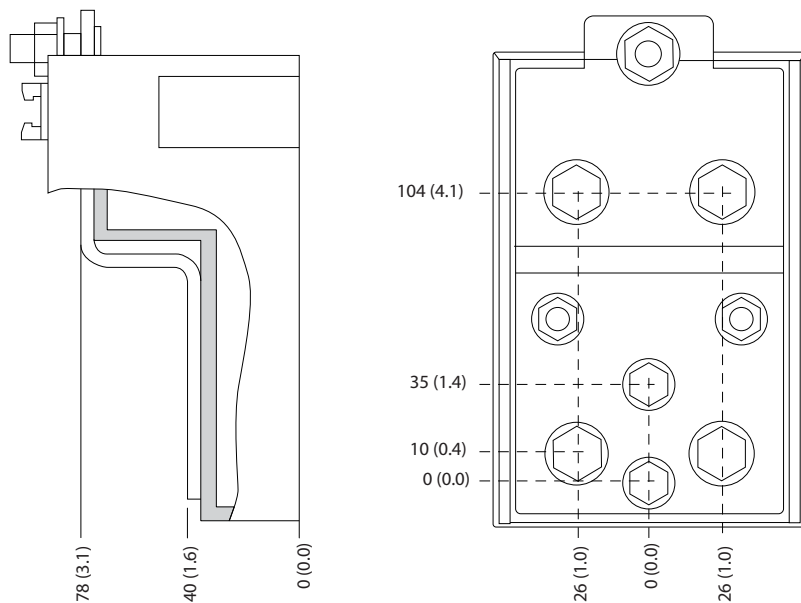

130BF647.10

Illustration 8.3 Detailed Terminal Dimensions for E1/E2

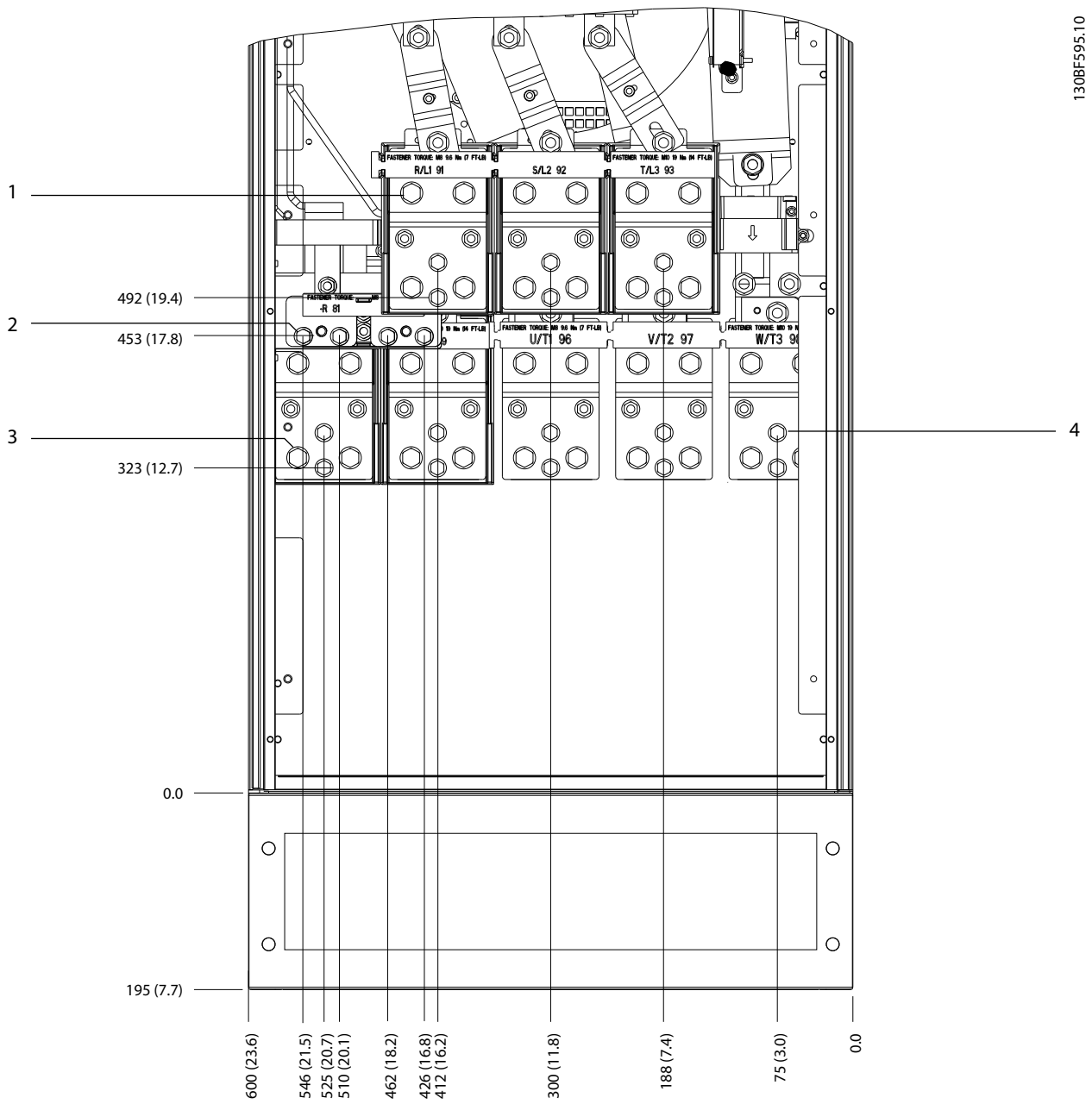

1	Mains terminals	3	Regen/load share terminals
2	Brake terminals	4	Motor terminals

Illustration 8.4 Terminal Dimensions for E1, Front View

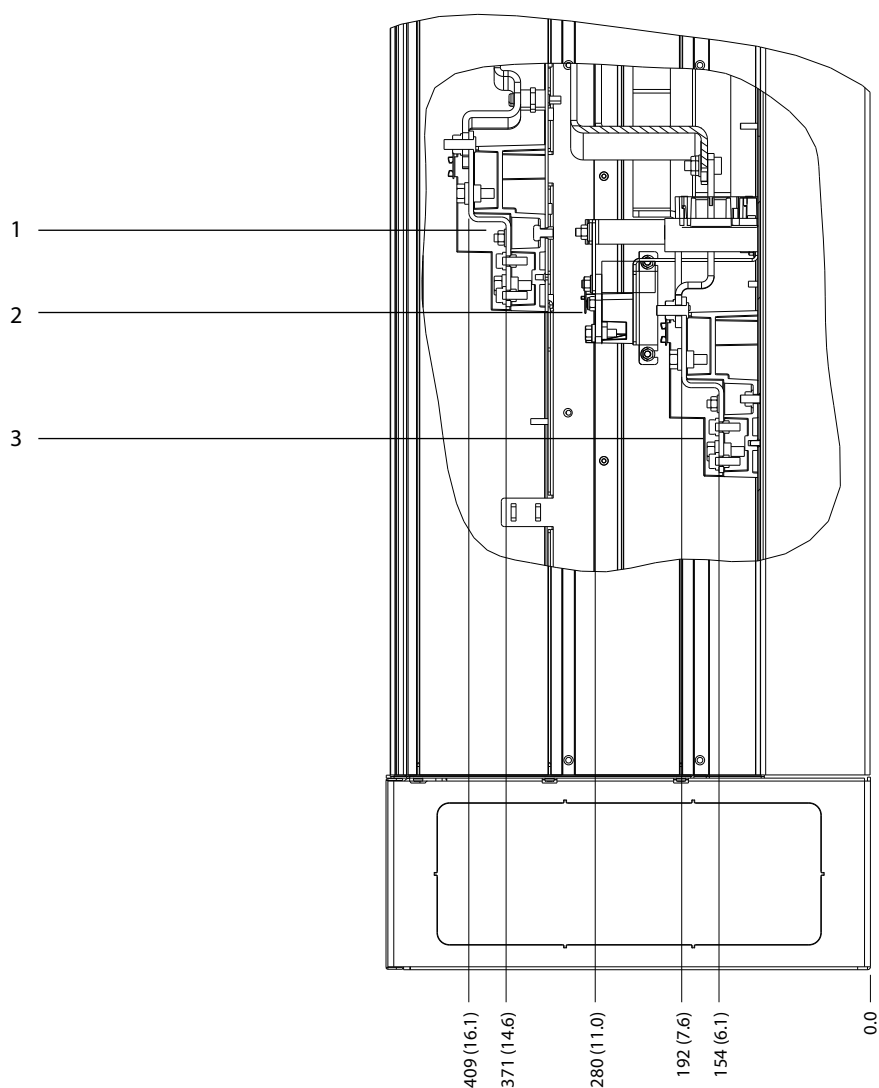

1	Mains terminals	2	Brake terminals
3	Motor terminals	-	-

Illustration 8.5 Terminal Dimensions for E1, Side View



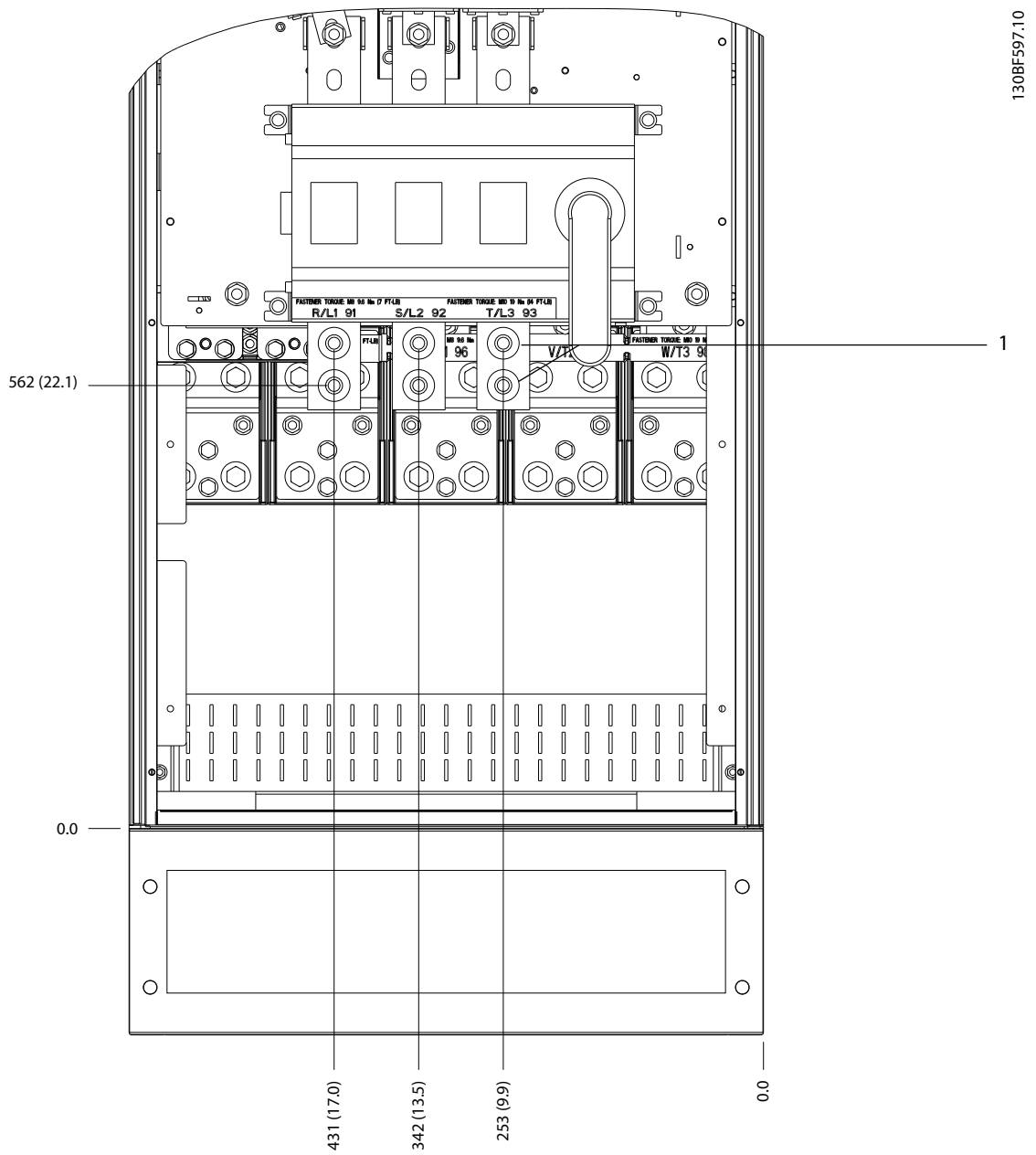

8

1	Mains terminals	-	-
---	-----------------	---	---

Illustration 8.6 Terminal Dimensions for E1 with Disconnect (380–480/500 V Models: P315; 525–690 V Models: P355–P560), Front View

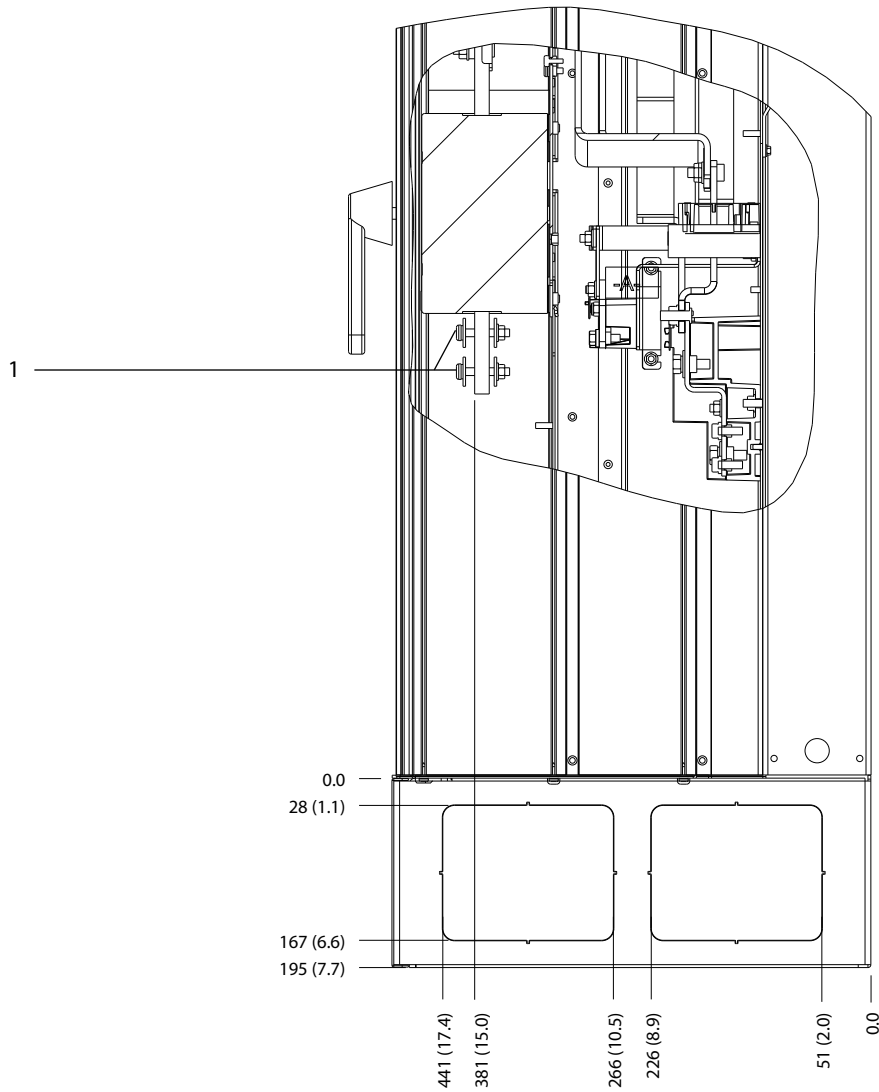

1	Mains terminals	-	-
---	-----------------	---	---

Illustration 8.7 Terminal Dimensions for E1 with Disconnect (380–480/500 V Models: P315; 525–690 V Models: P355–P560), Side View

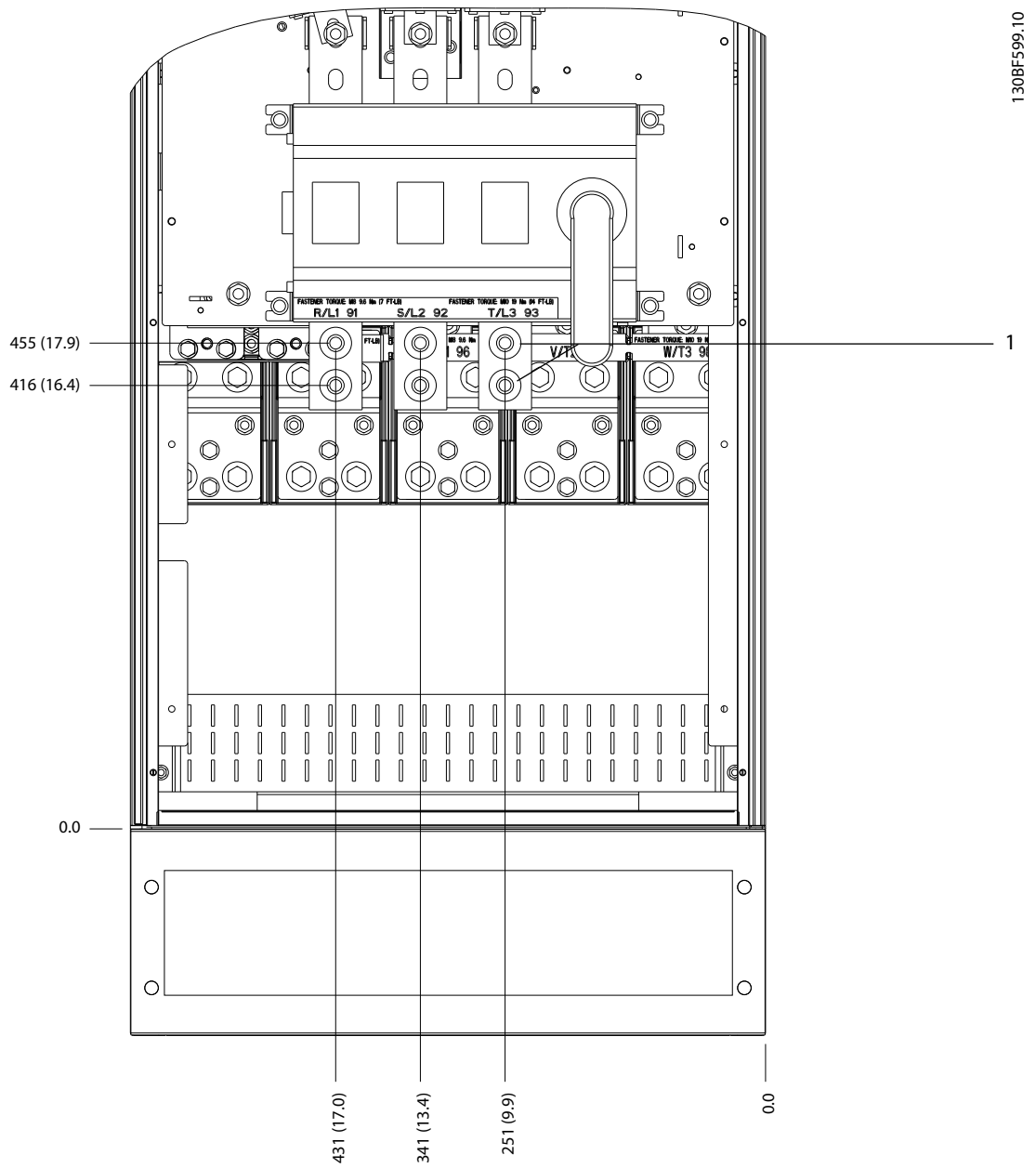

8

1	Mains terminals	-	-
---	-----------------	---	---

Illustration 8.8 Terminal Dimensions for E1 with Disconnect (380–480/500 V Models: P355–P400), Front View

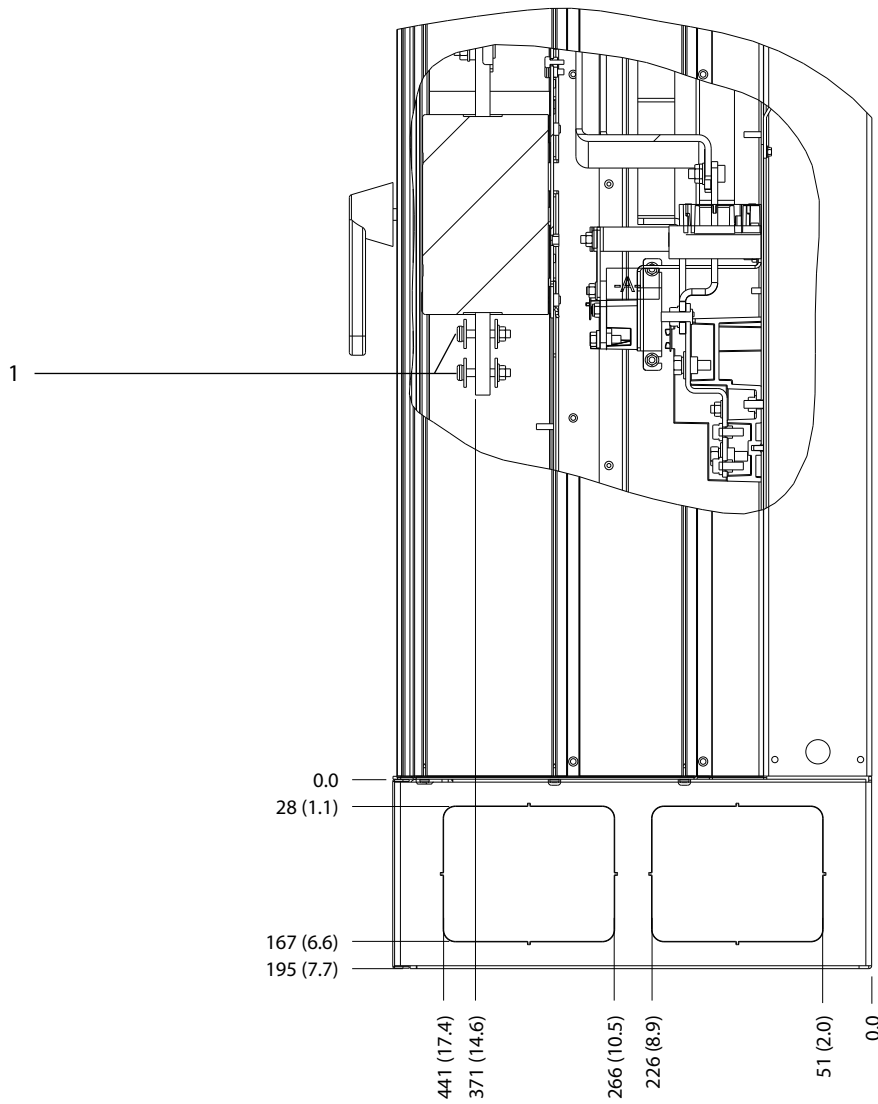

1	Mains terminals	-	-
---	-----------------	---	---

Illustration 8.9 Terminal Dimensions for E1 with Disconnect (380–480/500 V Models: P355–P400), Side View

8.2 E2 Exterior and Terminal Dimensions

8.2.1 E2 Exterior Dimensions

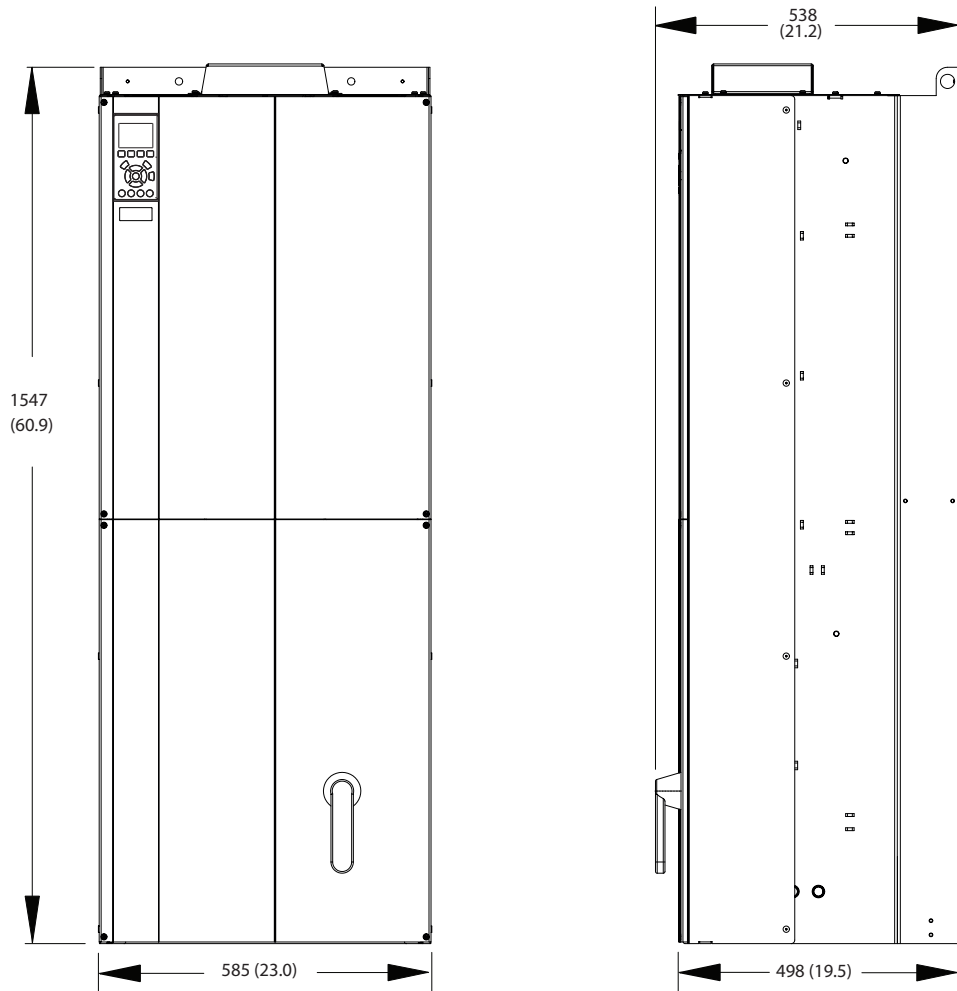

130BF329.10

Illustration 8.10 Front, Side, and Door Clearance Dimensions for E2

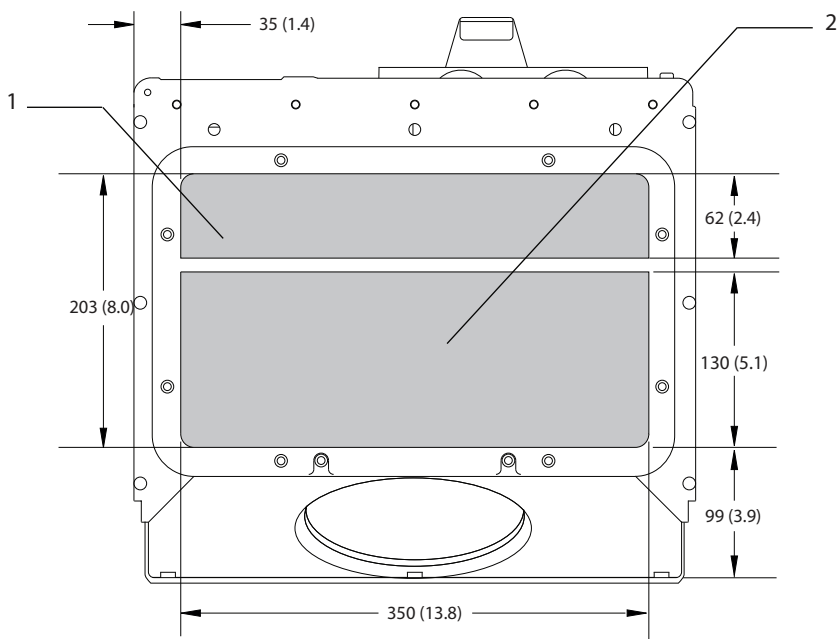

130BF611.10

8

1	Mains side	2	Motor side
---	------------	---	------------

Illustration 8.11 Gland Plate Dimensions for E1/E2

### 8.2.2 E2 Terminal Dimensions

Power cables are heavy and hard to bend. To ensure easy installation of the cables, consider the optimum placement of the drive. Each terminal allows up to 4 cables with cable lugs or a standard box lug. Ground is connected to a relevant termination point in the drive.

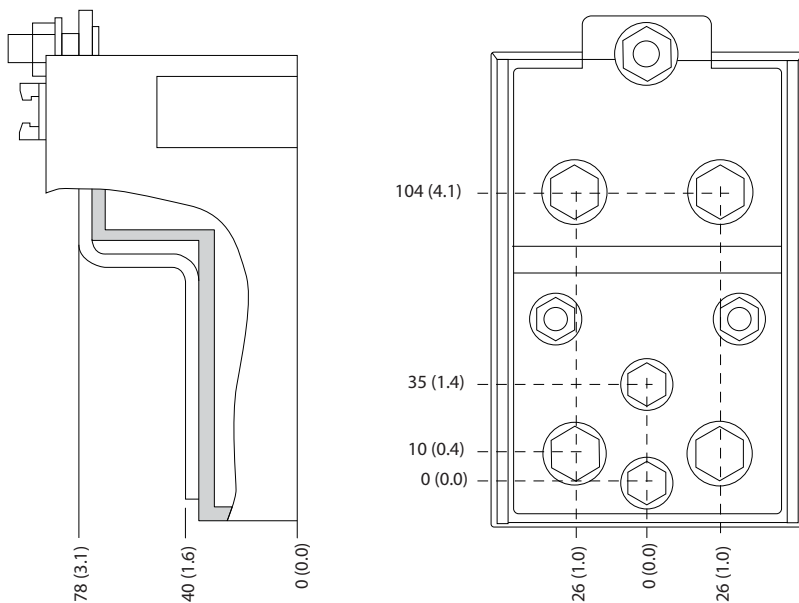

130BF647.10

Illustration 8.12 Detailed Terminal Dimensions for E1/E2

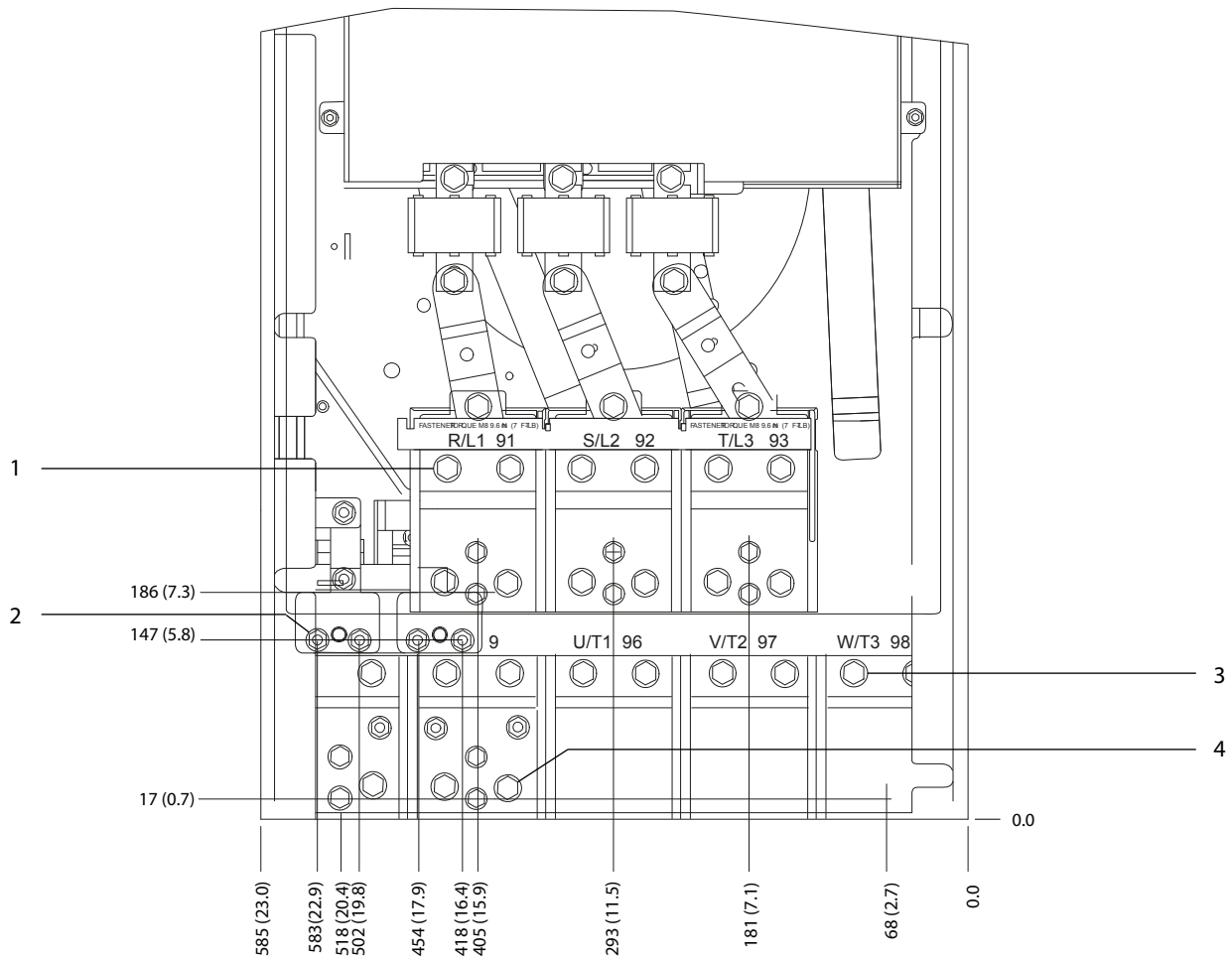

1	Mains terminals	3	Motor terminals
2	Brake terminals	4	Regen/load share terminals

Illustration 8.13 Terminal Dimensions for E2, Front View

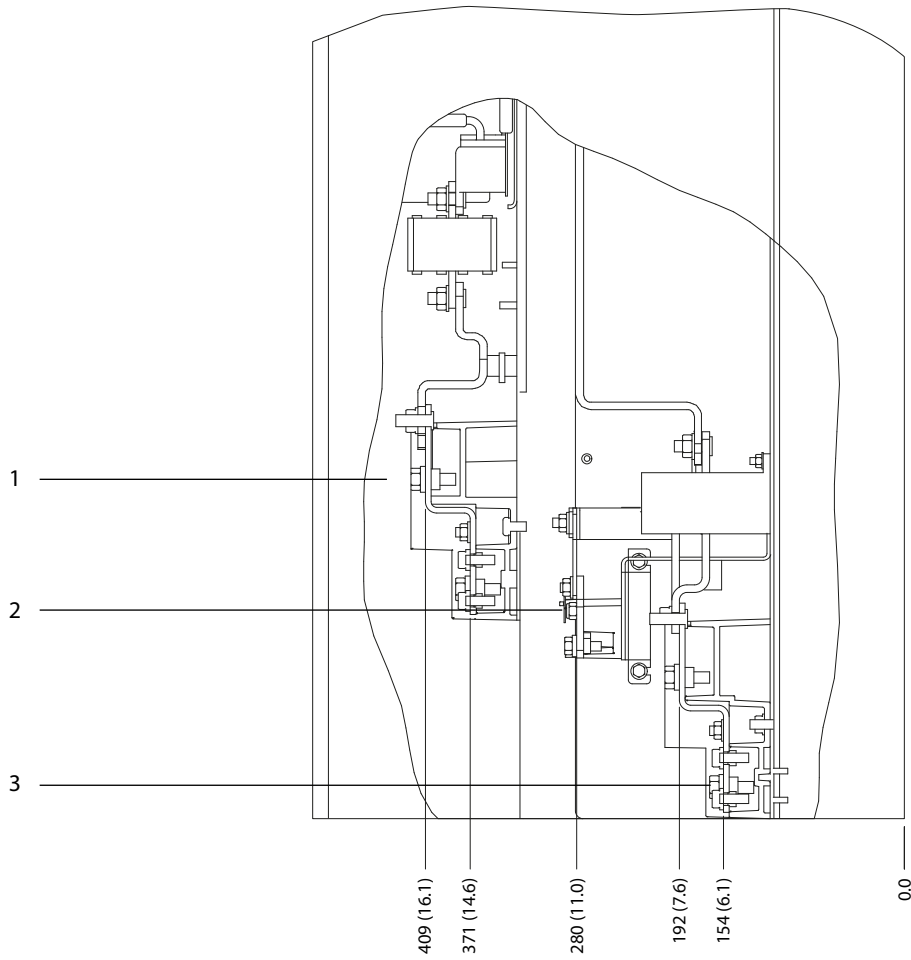

1	Mains terminals	2	Brake terminals
3	Motor terminals	-	-

Illustration 8.14 Terminal Dimensions for E2, Side View



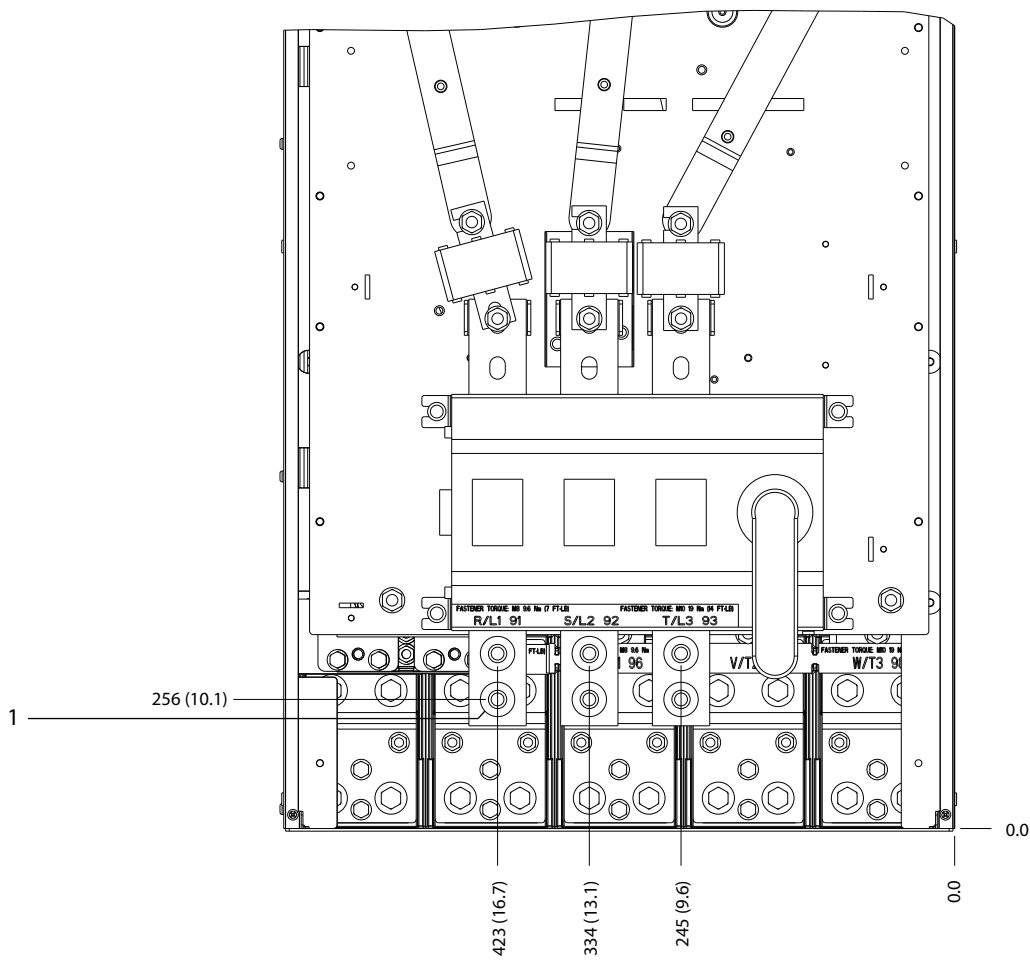

1	Mains terminals	-	-
---	-----------------	---	---

Illustration 8.15 Terminal Dimensions for E2 with Disconnect (380–480/500 V Models: P315; 525–690 V Models: P355–P560), Front View

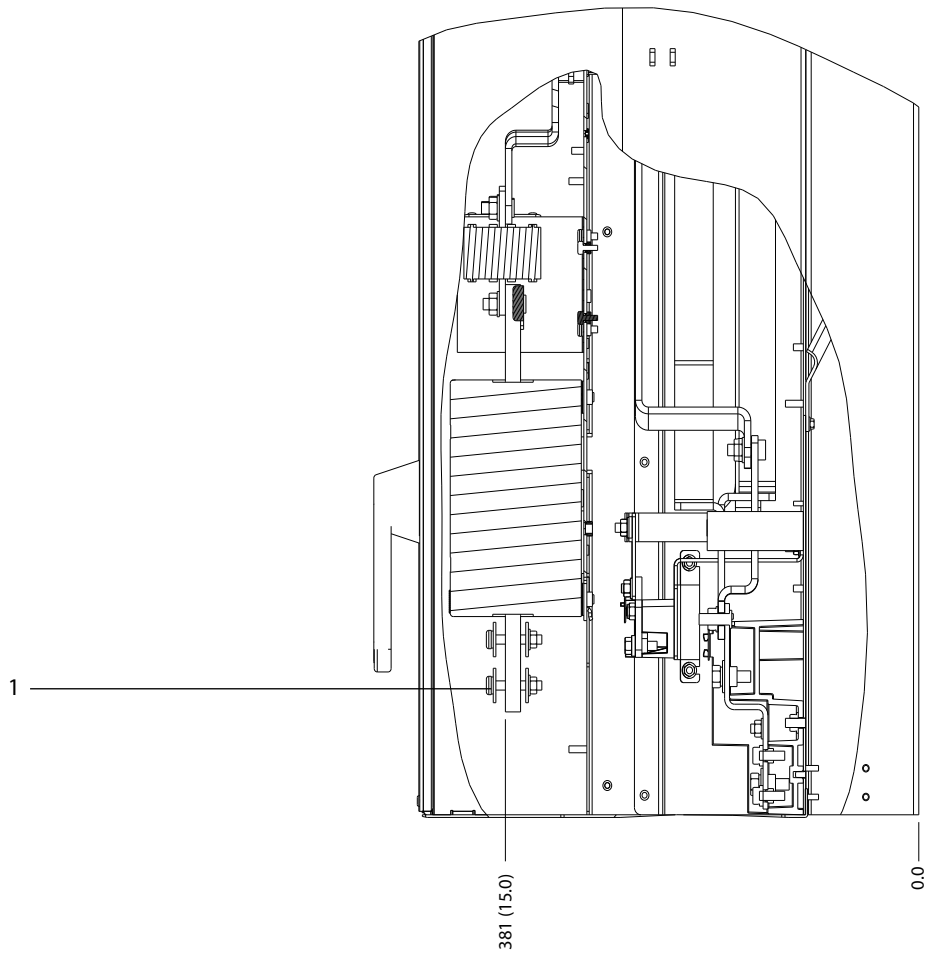

130BF604.10

1	Mains terminals	-	-
---	-----------------	---	---

Illustration 8.16 Terminal Dimensions for E2 with Disconnect (380–480/500 V Models: P315; 525–690 V Models: P355–P560), Side View

1308F605.10

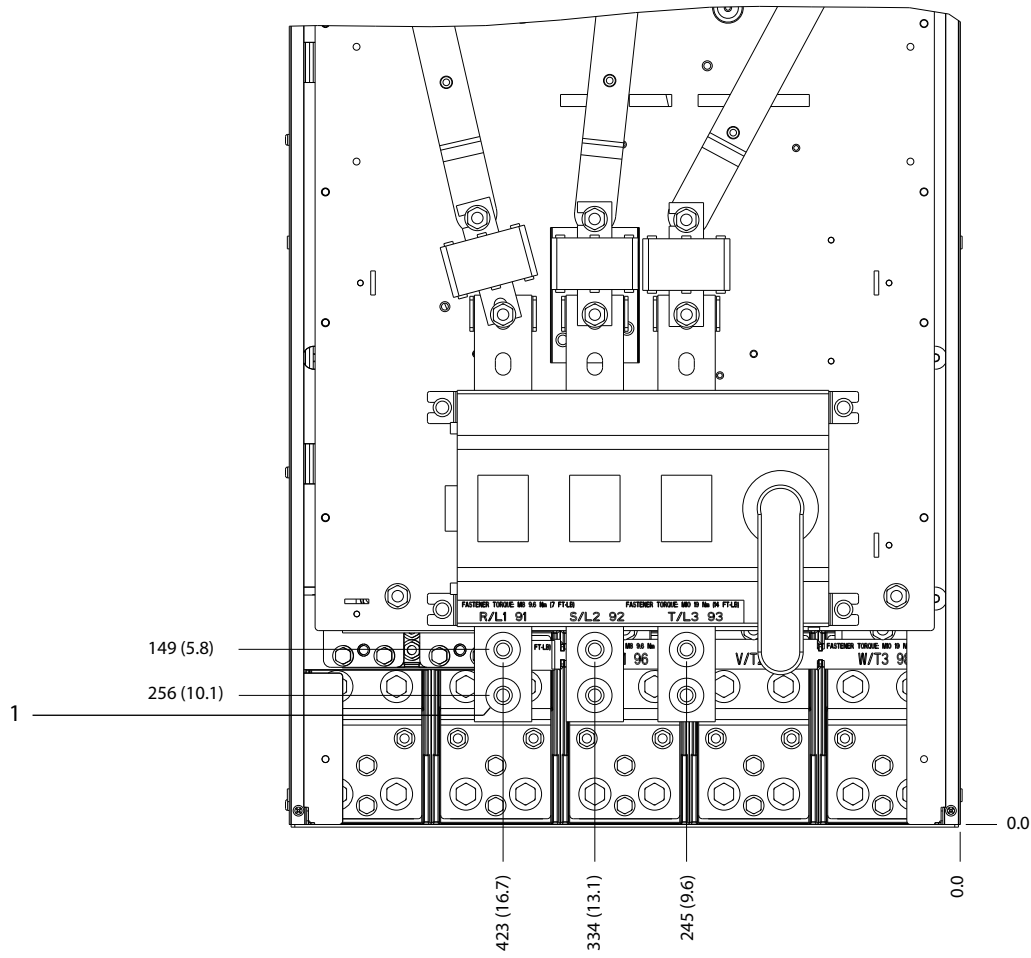

8

1	Mains terminals	-	-
---	-----------------	---	---

Illustration 8.17 Terminal Dimensions for E2 with Disconnect (380–480/500 V Models: P355–P400), Front View

8

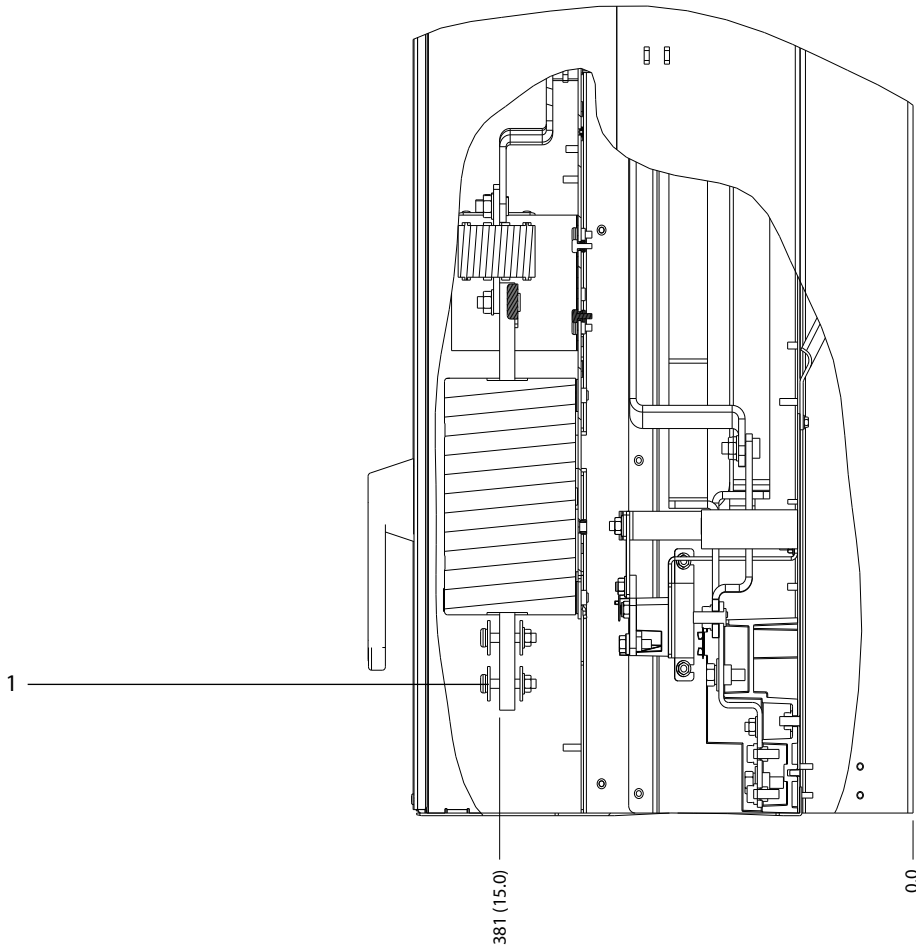

1	Mains terminals	-	-
---	-----------------	---	---

Illustration 8.18 Terminal Dimensions for E2 with Disconnect (380–480/500 V Models: P355–P400), Side View

### 8.3 F1 Exterior and Terminal Dimensions

#### 8.3.1 F1 Exterior Dimensions

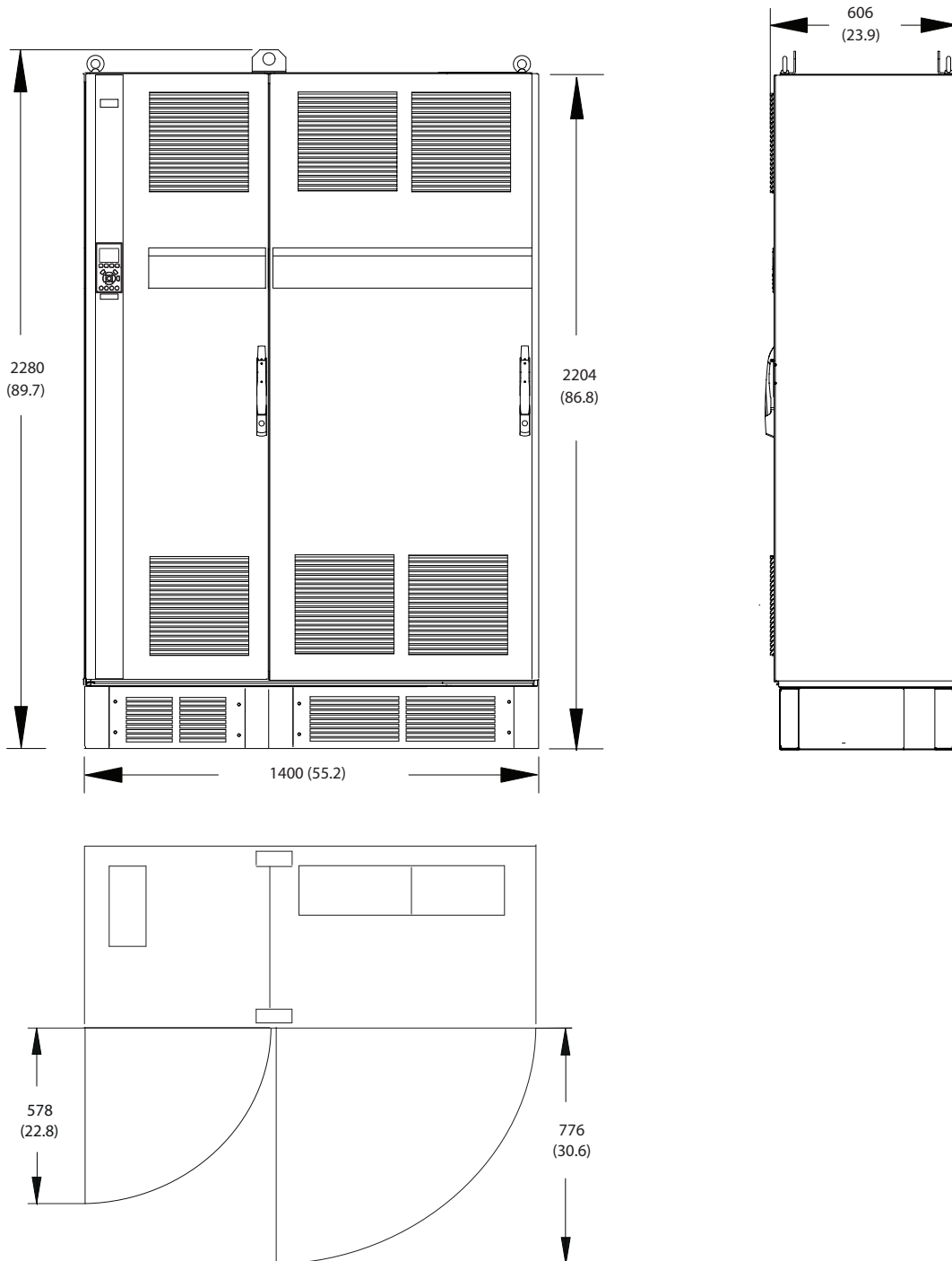

130BF375.10

Illustration 8.19 Front, Side, and Door Clearance Dimensions for F1

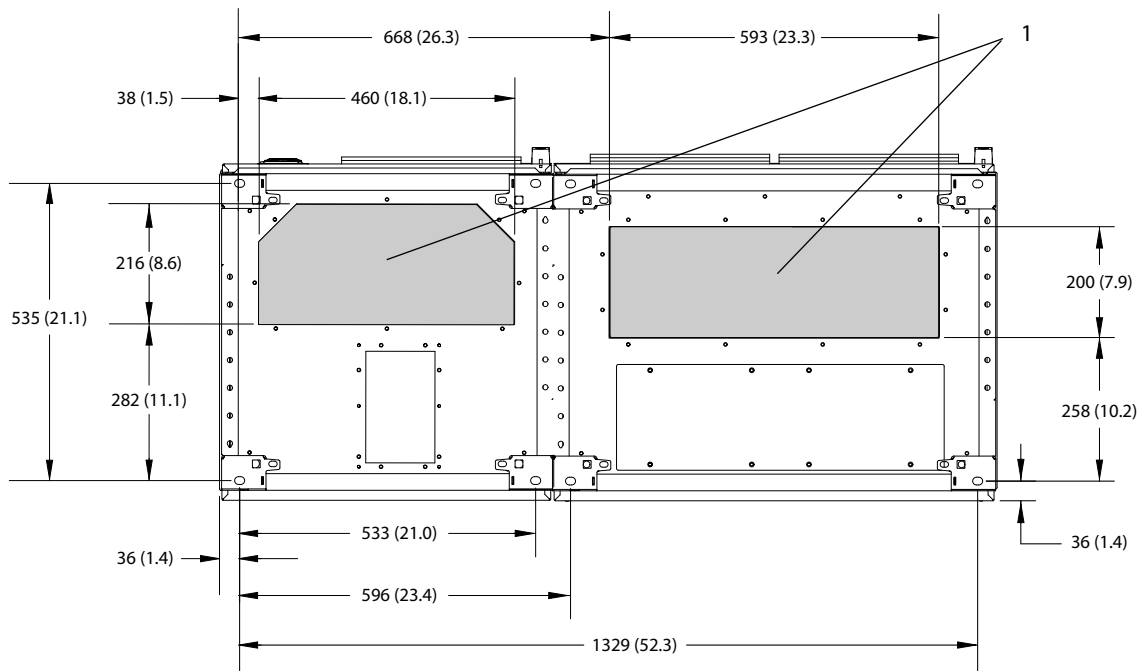

130BF612.10

8

1	Mains side	2	Motor side
---	------------	---	------------

Illustration 8.20 Gland Plate Dimensions for F1

### 8.3.2 F1 Terminal Dimensions

Power cables are heavy and hard to bend. To ensure easy installation of the cables, consider the optimum placement of the drive. Each terminal allows up to 4 cables with cable lugs or a standard box lug. Ground is connected to a relevant termination point in the drive.

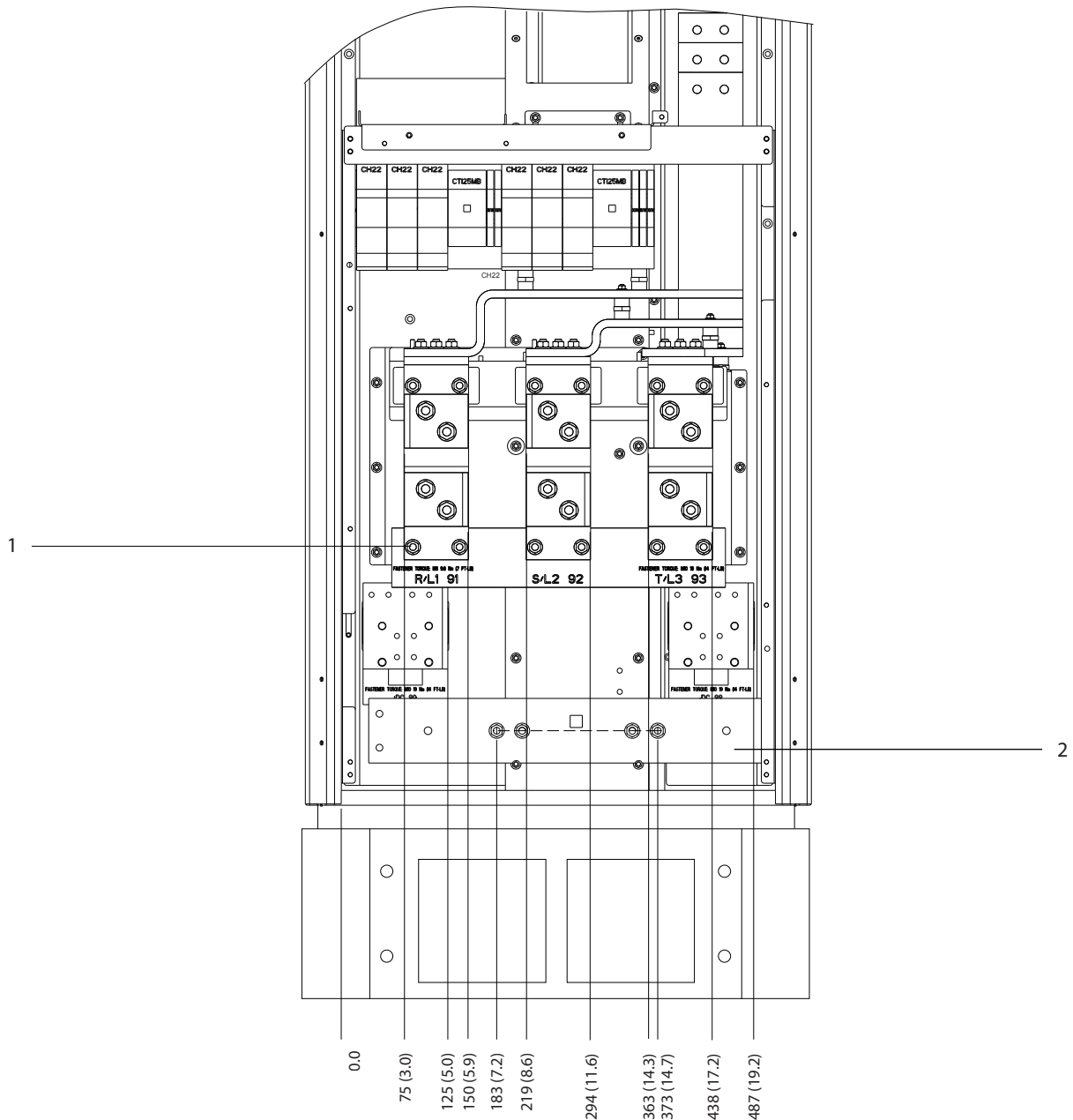

1	Mains terminals	2	Ground bar
---	-----------------	---	------------

Illustration 8.21 Terminal Dimensions for F1–F4 Rectifier Cabinet, Front View

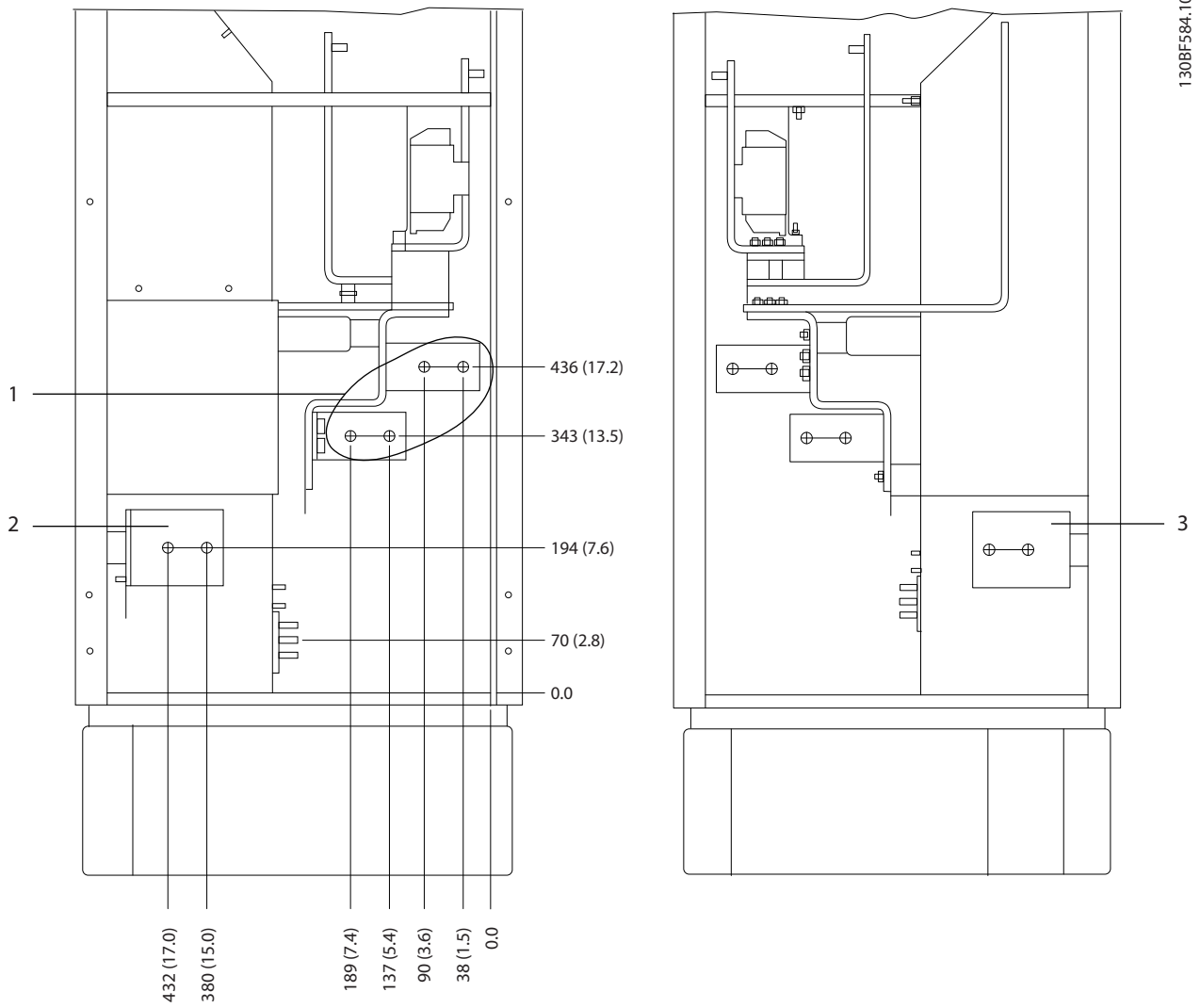

1	Mains terminals	3	Load share terminals (-)
2	Load share terminals (+)	-	-

Illustration 8.22 Terminal Dimensions for F1-F2 Rectifier Cabinet, Side View



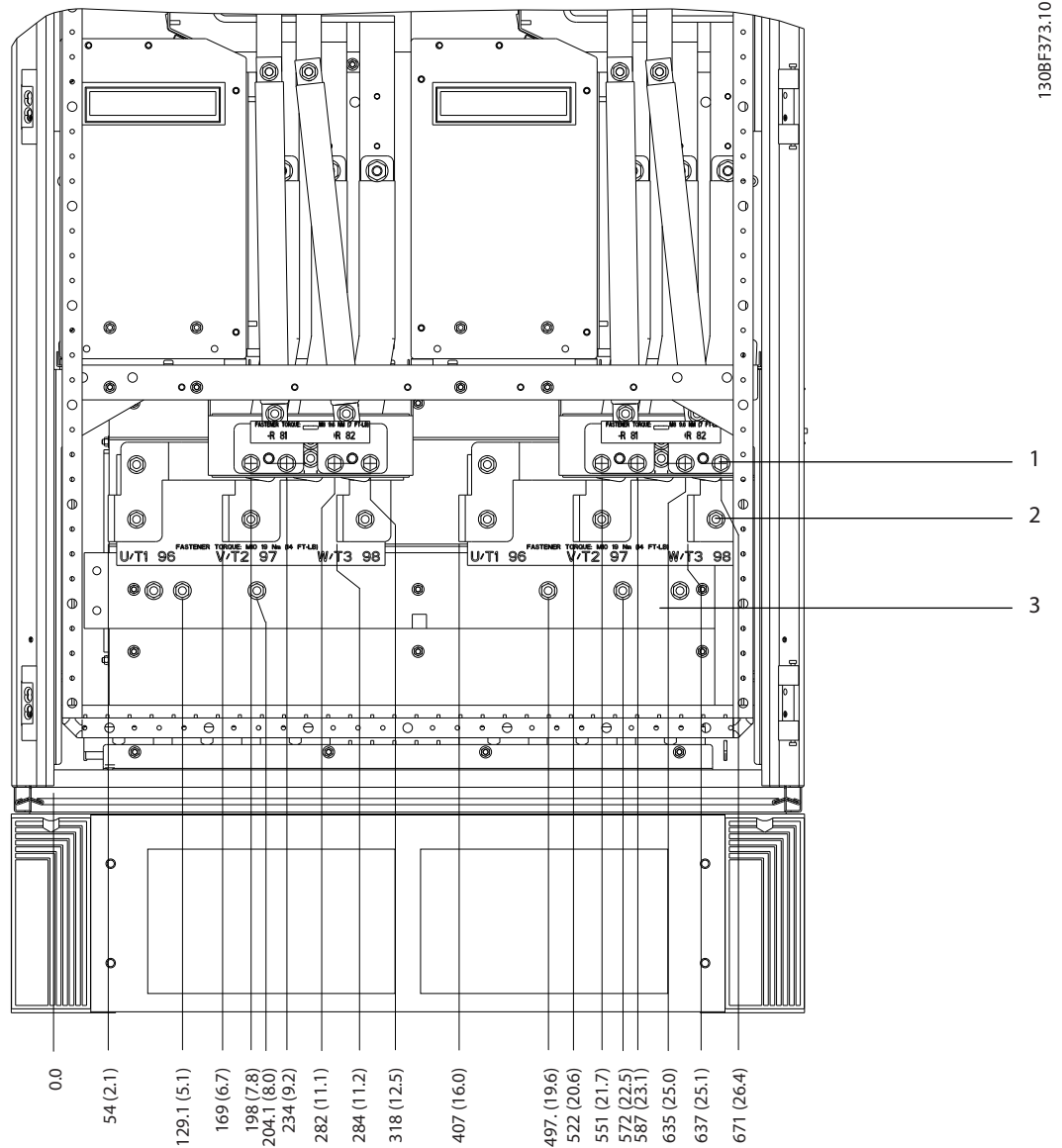

8

1	Brake terminals	3	Ground bar
2	Motor terminals	-	-

Illustration 8.23 Terminal Dimensions for F1/F3 Inverter Cabinet, Front View

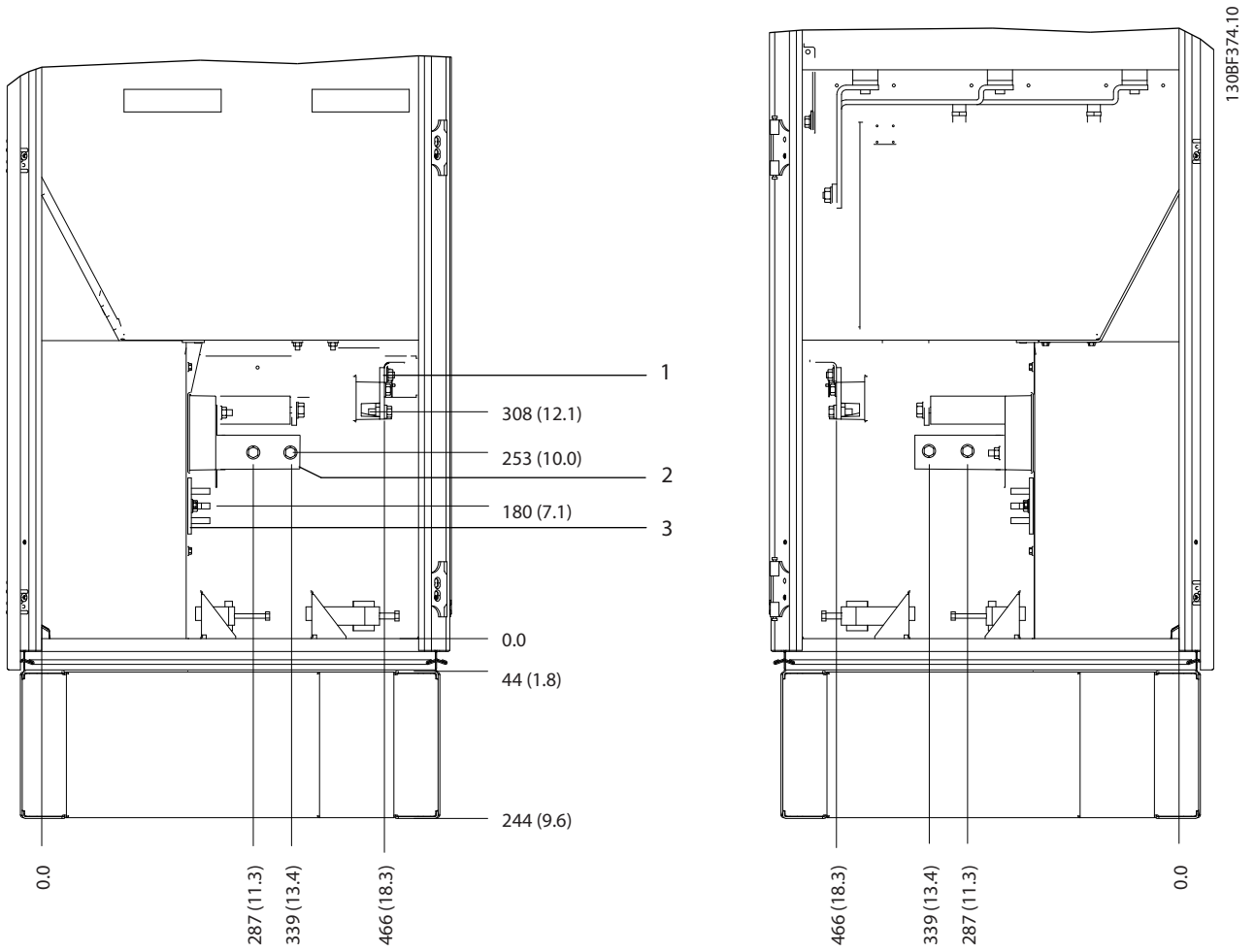

1	Brake terminals	3	Ground bar
2	Motor terminals	-	-

Illustration 8.24 Terminal Dimensions for F1/F3 Inverter Cabinet, Side View

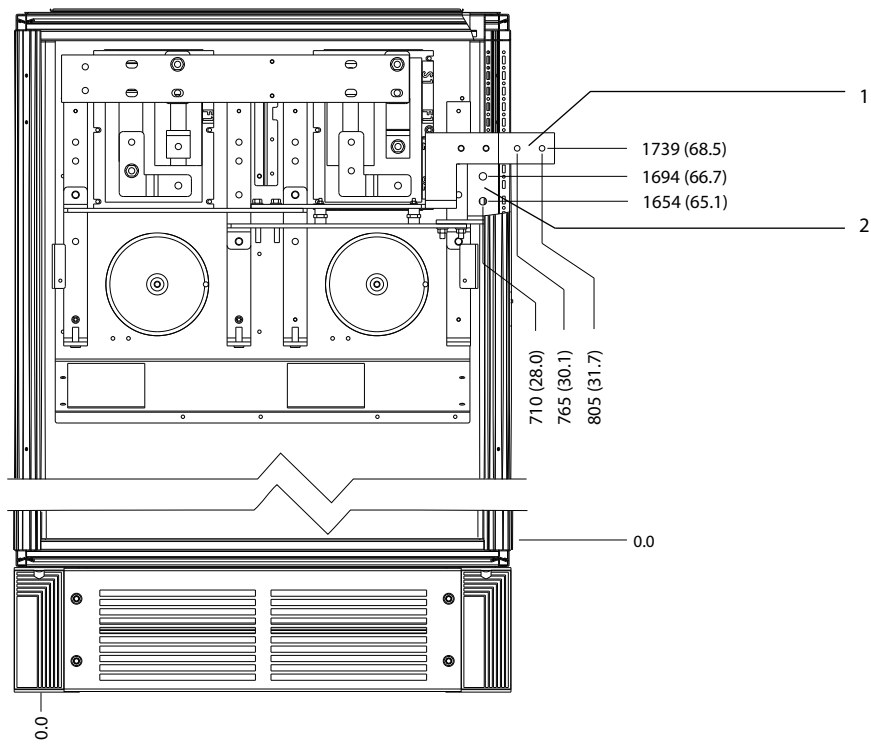

1308F365.10

1	DC -	2	DC +
---	------	---	------

Illustration 8.25 Terminal Dimensions for F1/F3 Regeneration Terminals, Front View

8.4 F2 Exterior and Terminal Dimensions

8.4.1 F2 Exterior Dimensions

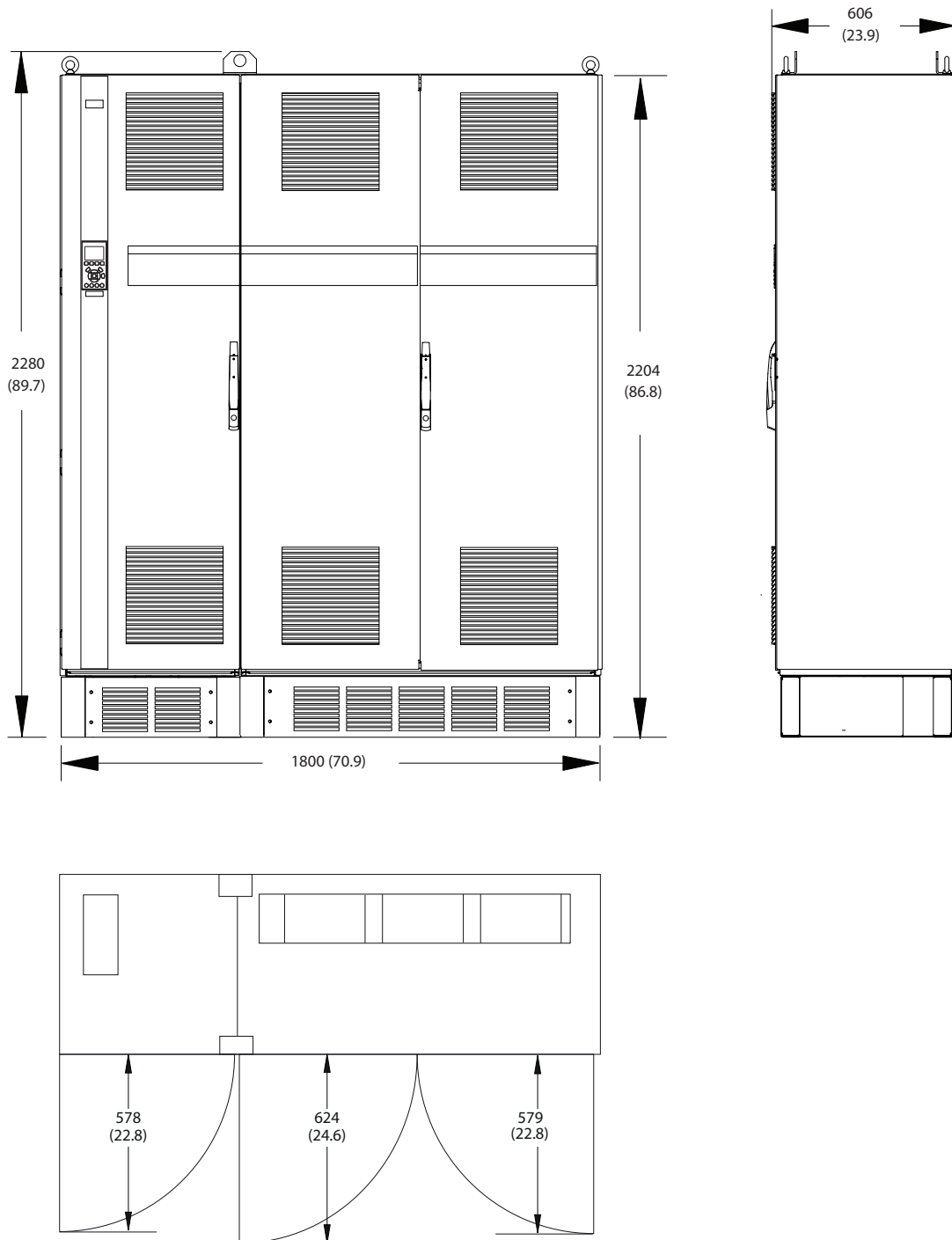

130BF330.11

8

Illustration 8.26 Front, Side, and Door Clearance Dimensions for F2

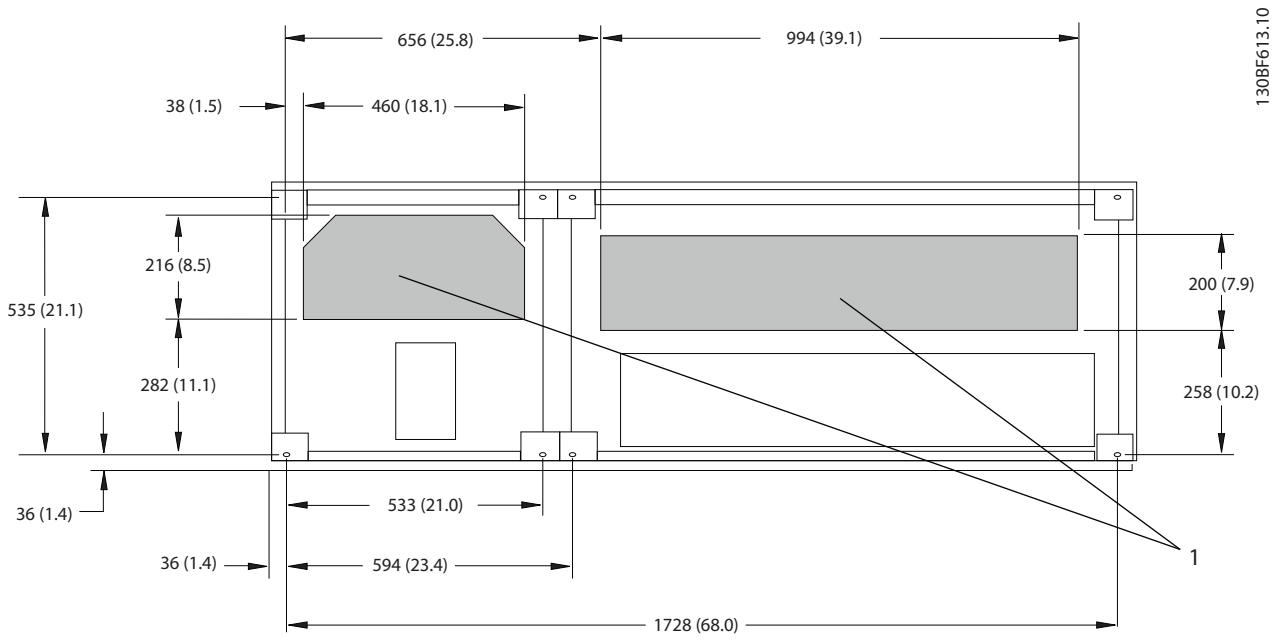

1	Mains side	2	Motor side
---	------------	---	------------

Illustration 8.27 Gland Plate Dimensions for F2

### 8.4.2 F2 Terminal Dimensions

Power cables are heavy and hard to bend. To ensure easy installation of the cables, consider the optimum placement of the drive. Each terminal allows up to 4 cables with cable lugs or a standard box lug. Ground is connected to a relevant termination point in the drive.

8

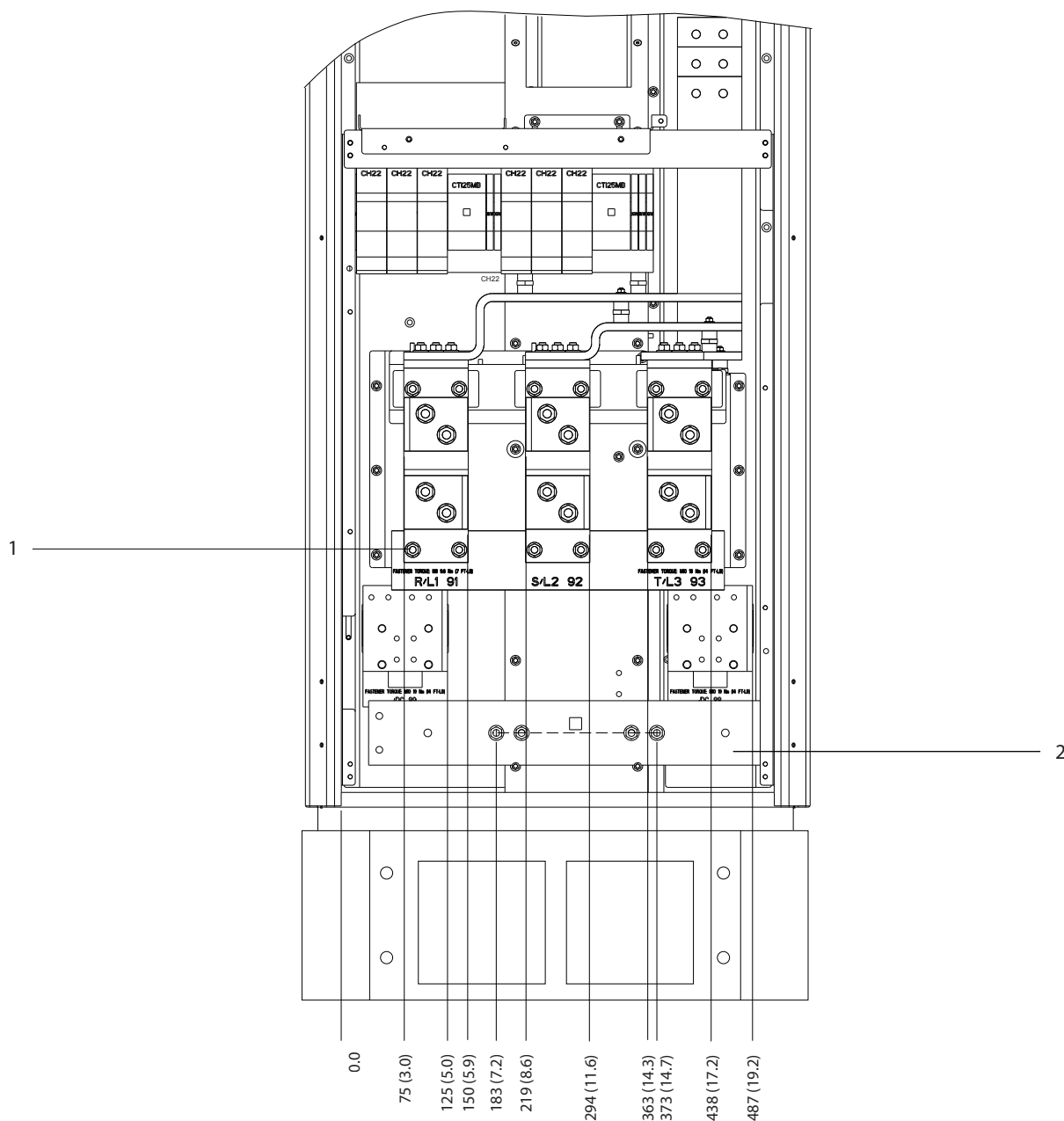

130BF583:10

1	Mains terminals	2	Ground bar
---	-----------------	---	------------

Illustration 8.28 Terminal Dimensions for F1–F4 Rectifier Cabinet, Front View

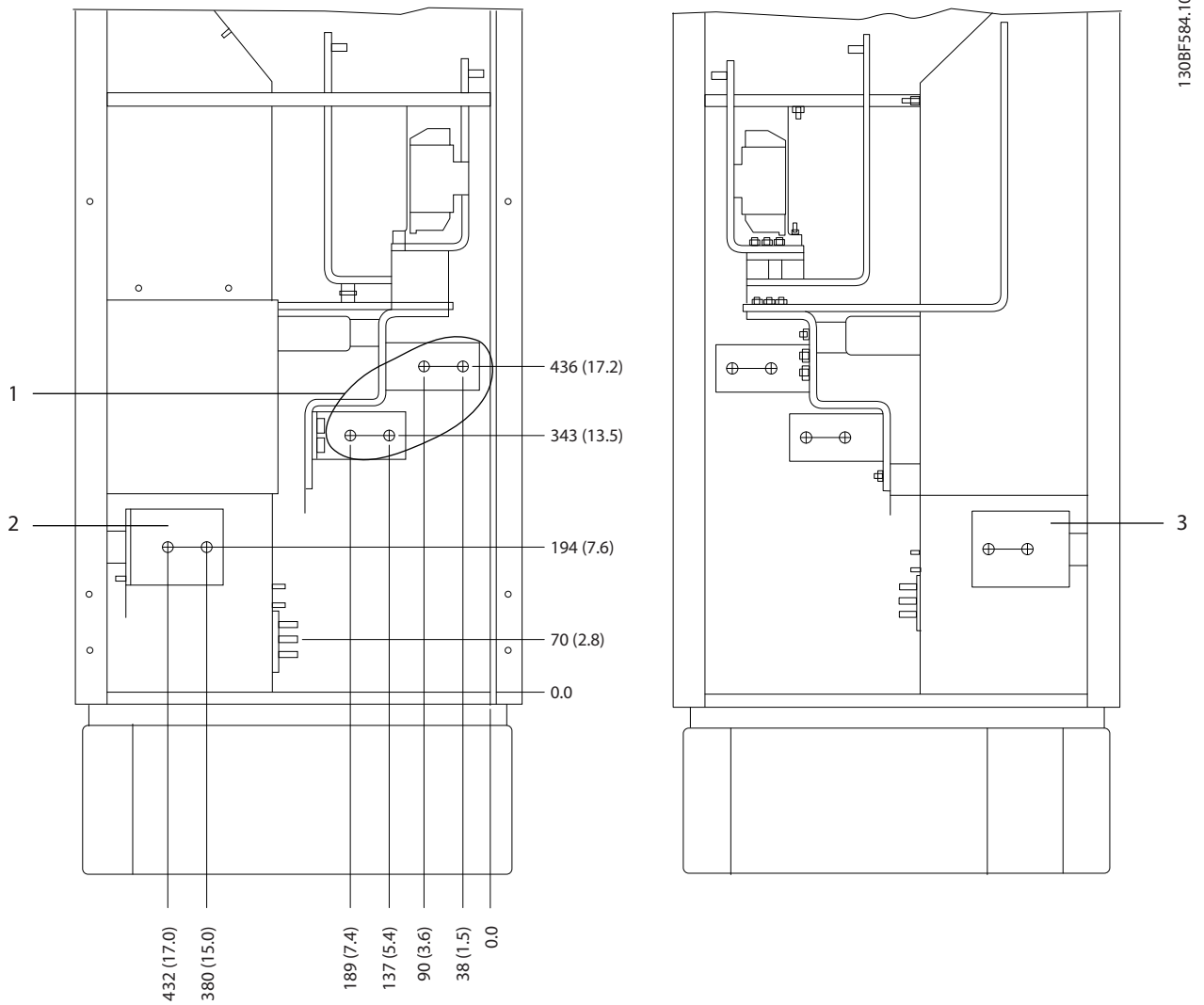

1	Mains terminals	3	Load share terminals (-)
2	Load share terminals (+)	-	-

Illustration 8.29 Terminal Dimensions for F1-F2 Rectifier Cabinet, Side View

1308F363.10

8

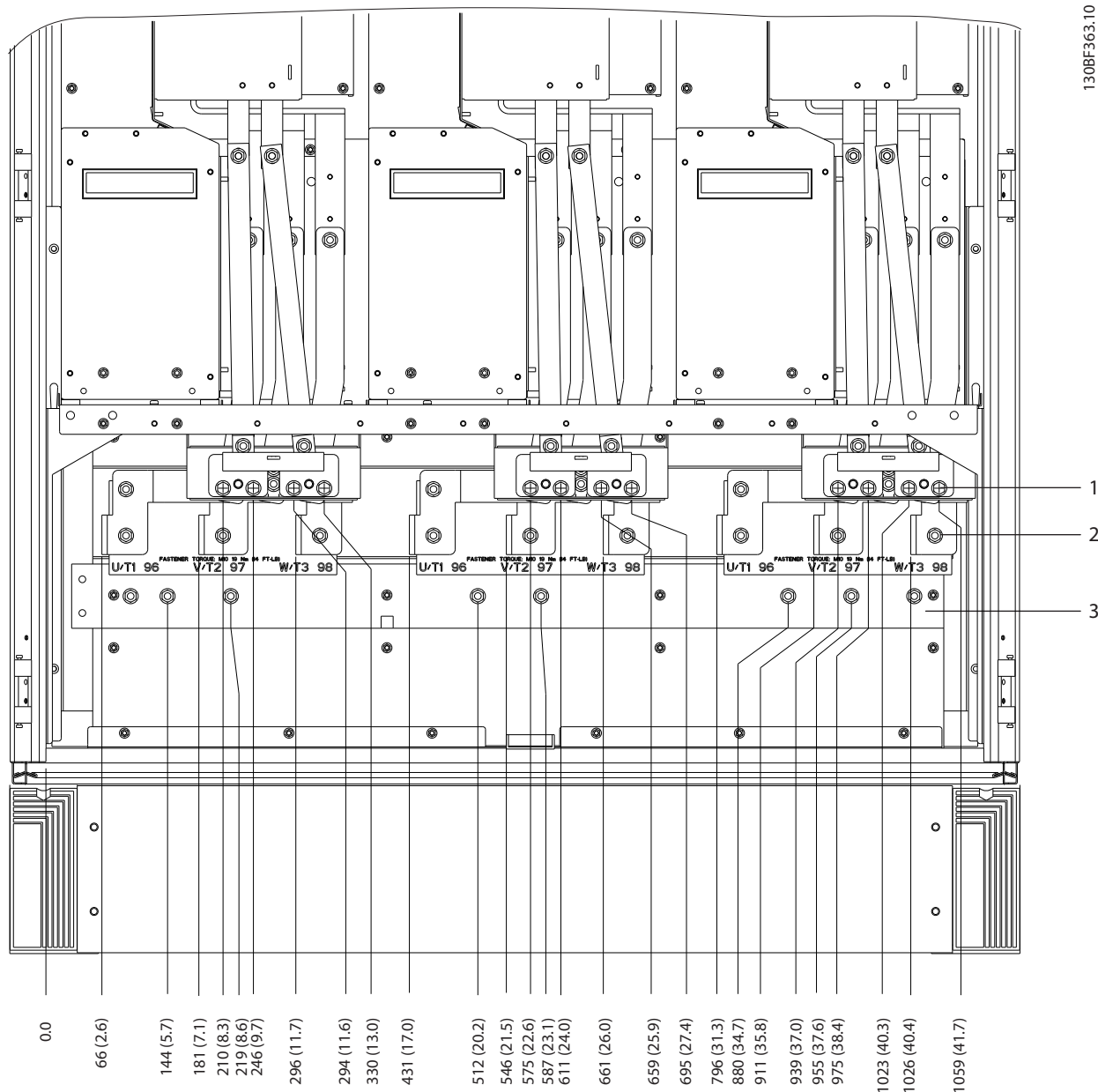

1	Brake terminals	3	Ground bar
2	Motor terminals	-	-

Illustration 8.30 Terminal Dimensions for F2/F4 Inverter Cabinet, Front View



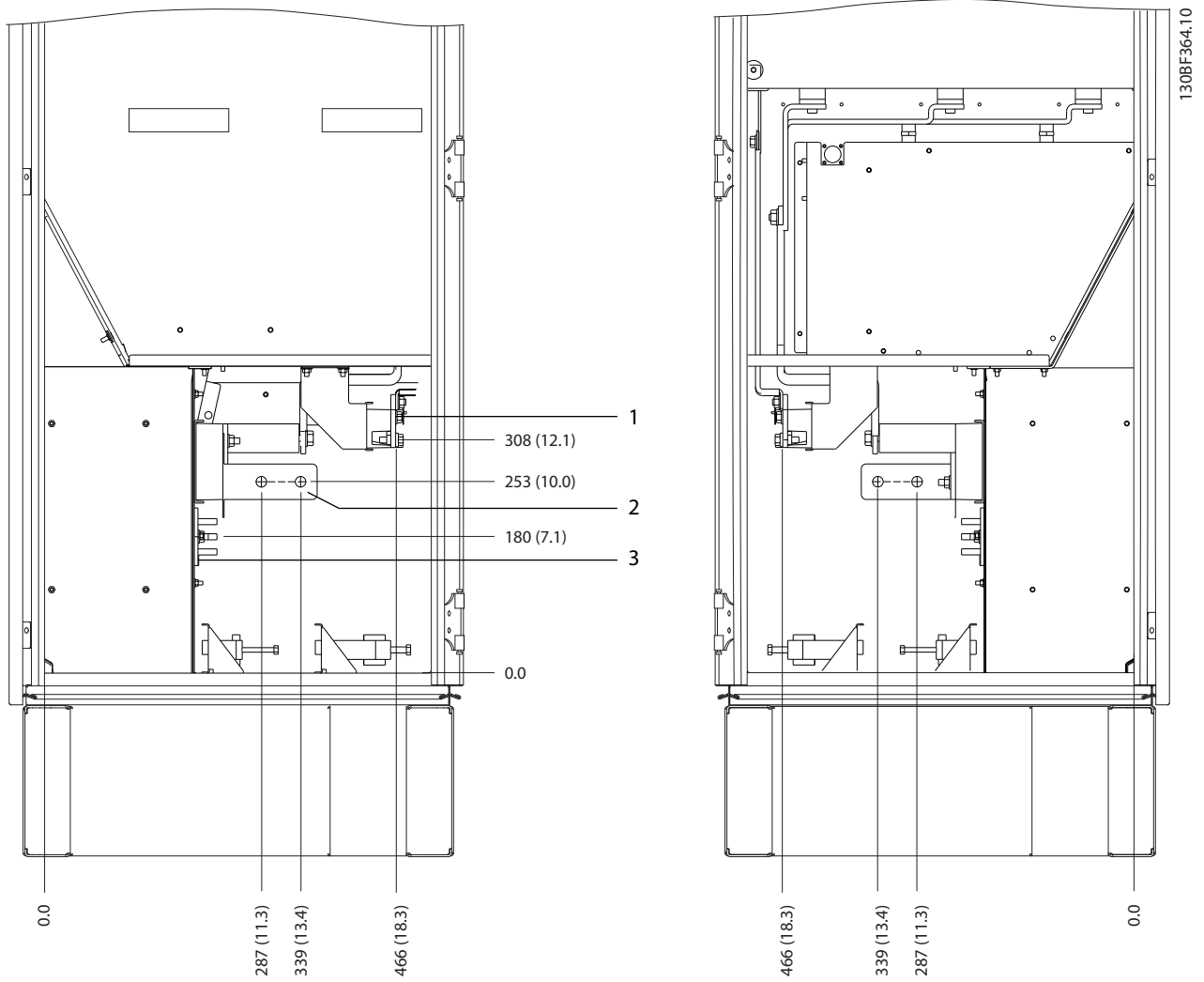

8

1	Brake terminals	3	Ground bar
2	Motor terminals	-	-

Illustration 8.31 Terminal Dimensions for F2/F4 Inverter Cabinet, Side View

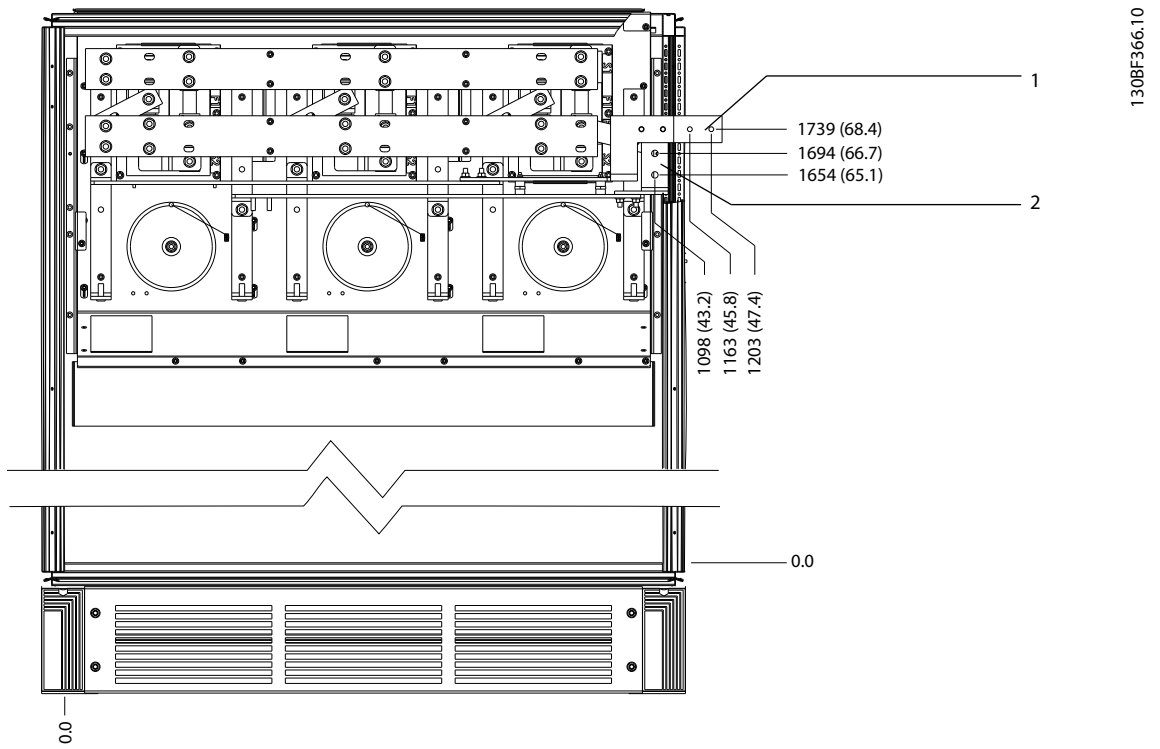

1	DC -	2	DC +
---	------	---	------

Illustration 8.32 Terminal Dimensions for F2/F4 Regeneration Terminals, Front View

## 8.5 F3 Exterior and Terminal Dimensions

### 8.5.1 F3 Exterior Dimensions

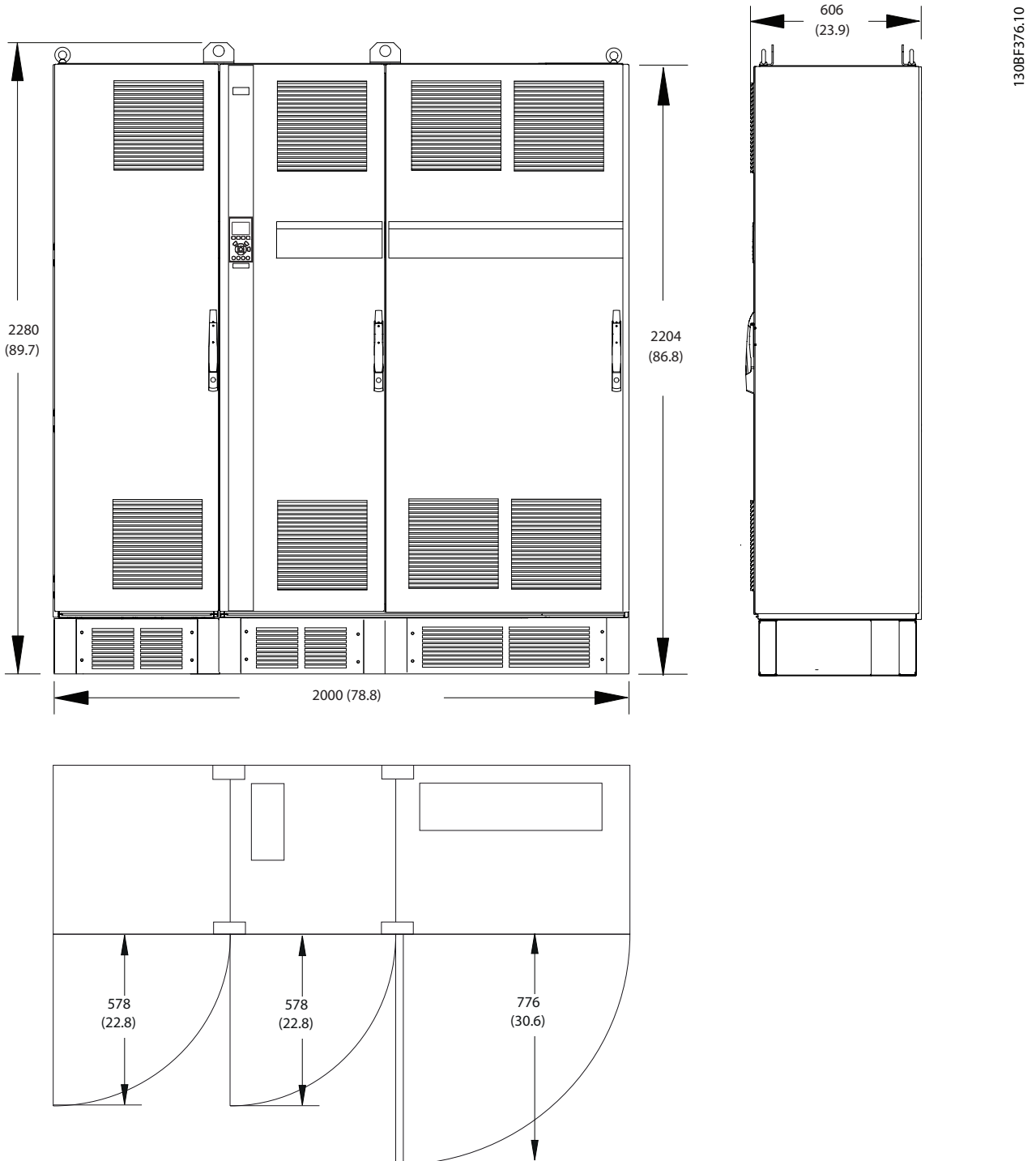

8

Illustration 8.33 Front, Side, and Door Clearance Dimensions for F3

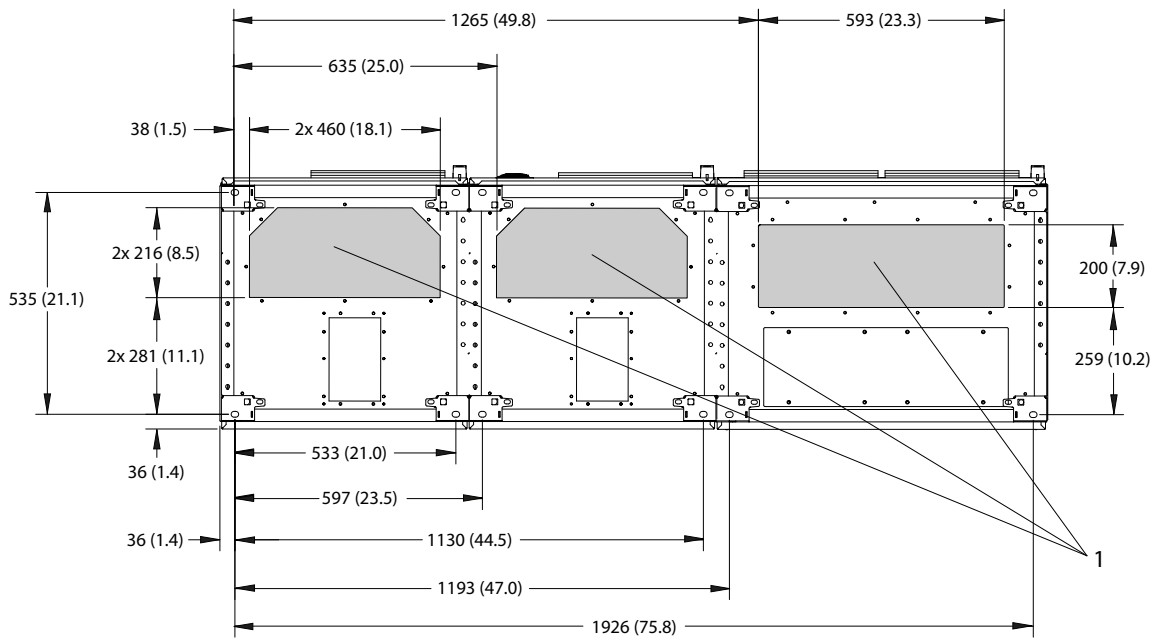

130BF614.10

8

1	Mains side	2	Motor side
---	------------	---	------------

Illustration 8.34 Gland Plate Dimensions for F3

### 8.5.2 F3 Terminal Dimensions

Power cables are heavy and hard to bend. To ensure easy installation of the cables, consider the optimum placement of the drive. Each terminal allows up to 4 cables with cable lugs or a standard box lug. Ground is connected to a relevant termination point in the drive.

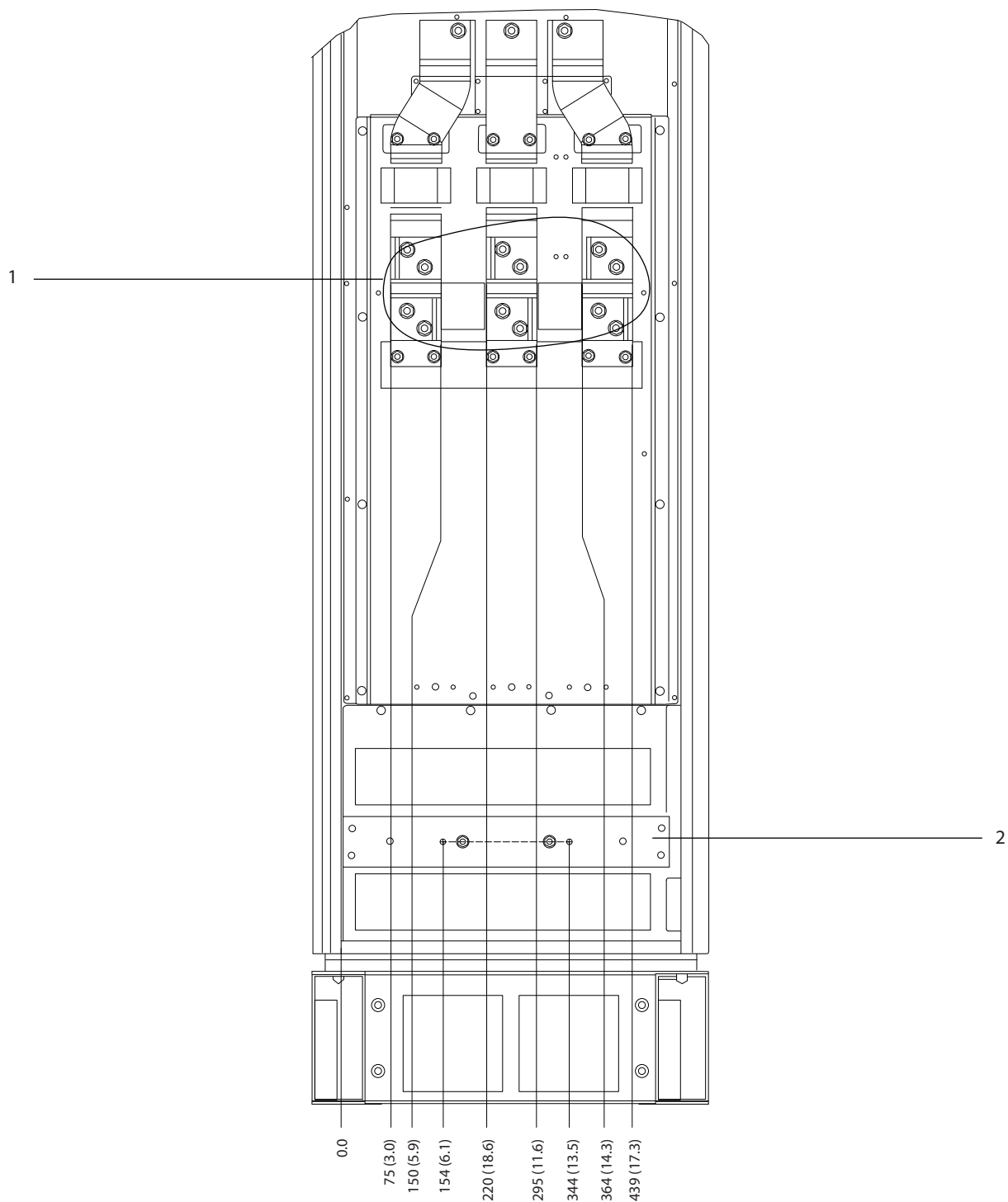

1	Mains terminals	2	Ground bar
---	-----------------	---	------------

Illustration 8.35 Terminal Dimensions for F3-F4 Options Cabinet, Front View

8

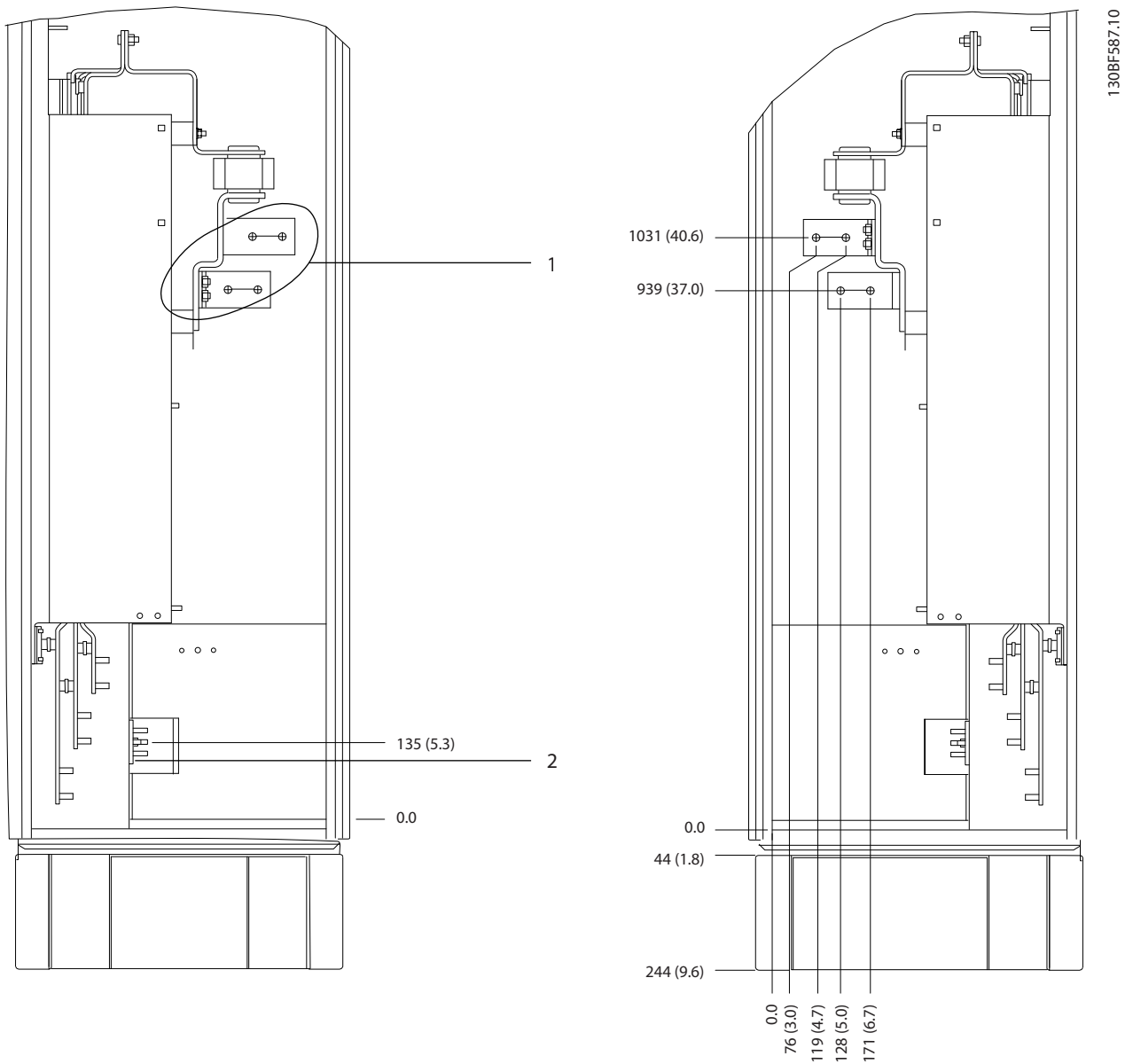

1	Mains terminals	2	Ground bar
---	-----------------	---	------------

Illustration 8.36 Terminal Dimensions for F3-F4 Options Cabinet, Side View

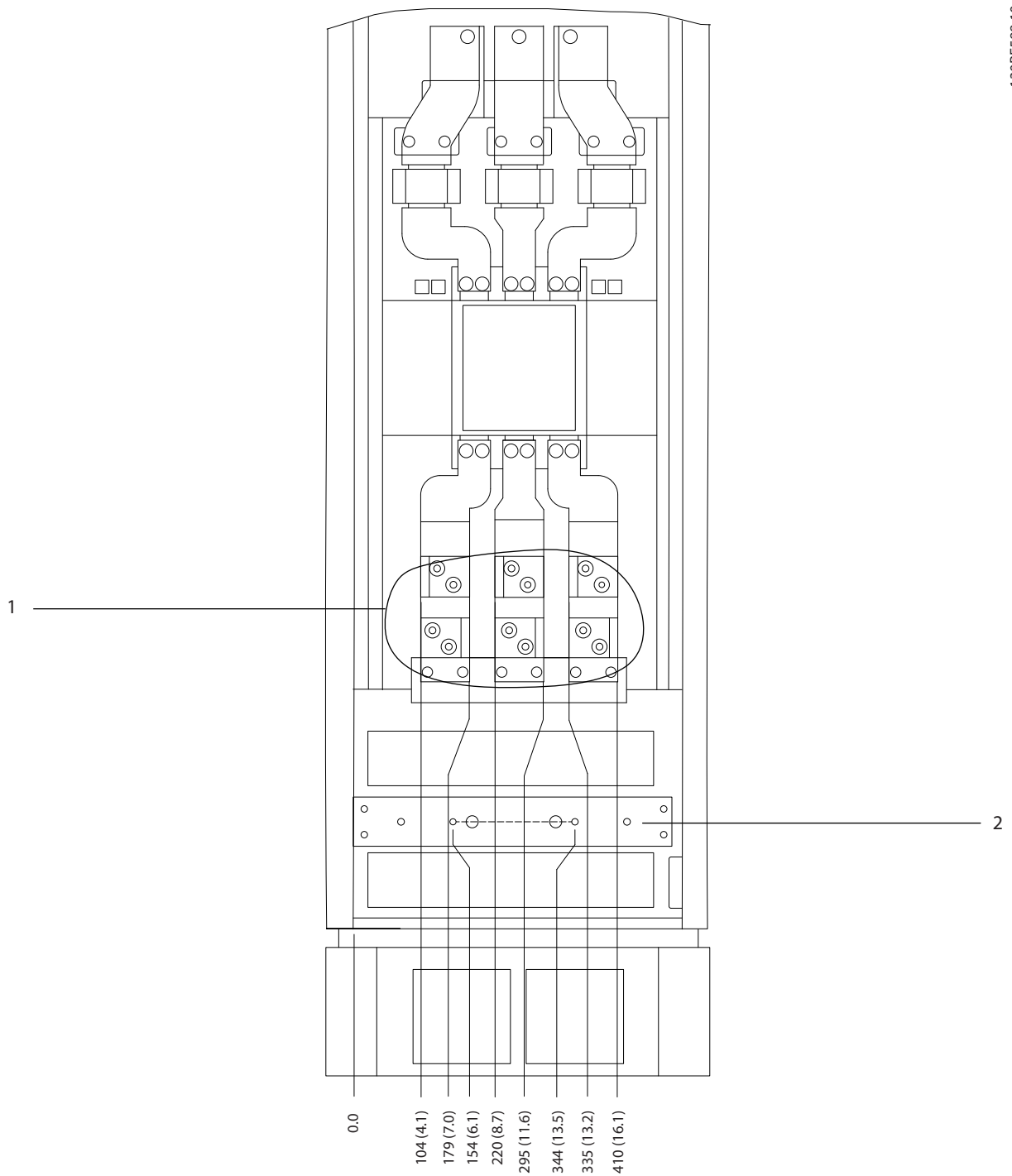

1	Mains terminals	2	Ground bar
---	-----------------	---	------------

Illustration 8.37 Terminal Dimensions for F3–F4 Options Cabinet with Circuit Breaker/Molded Case Switch, Front View

8

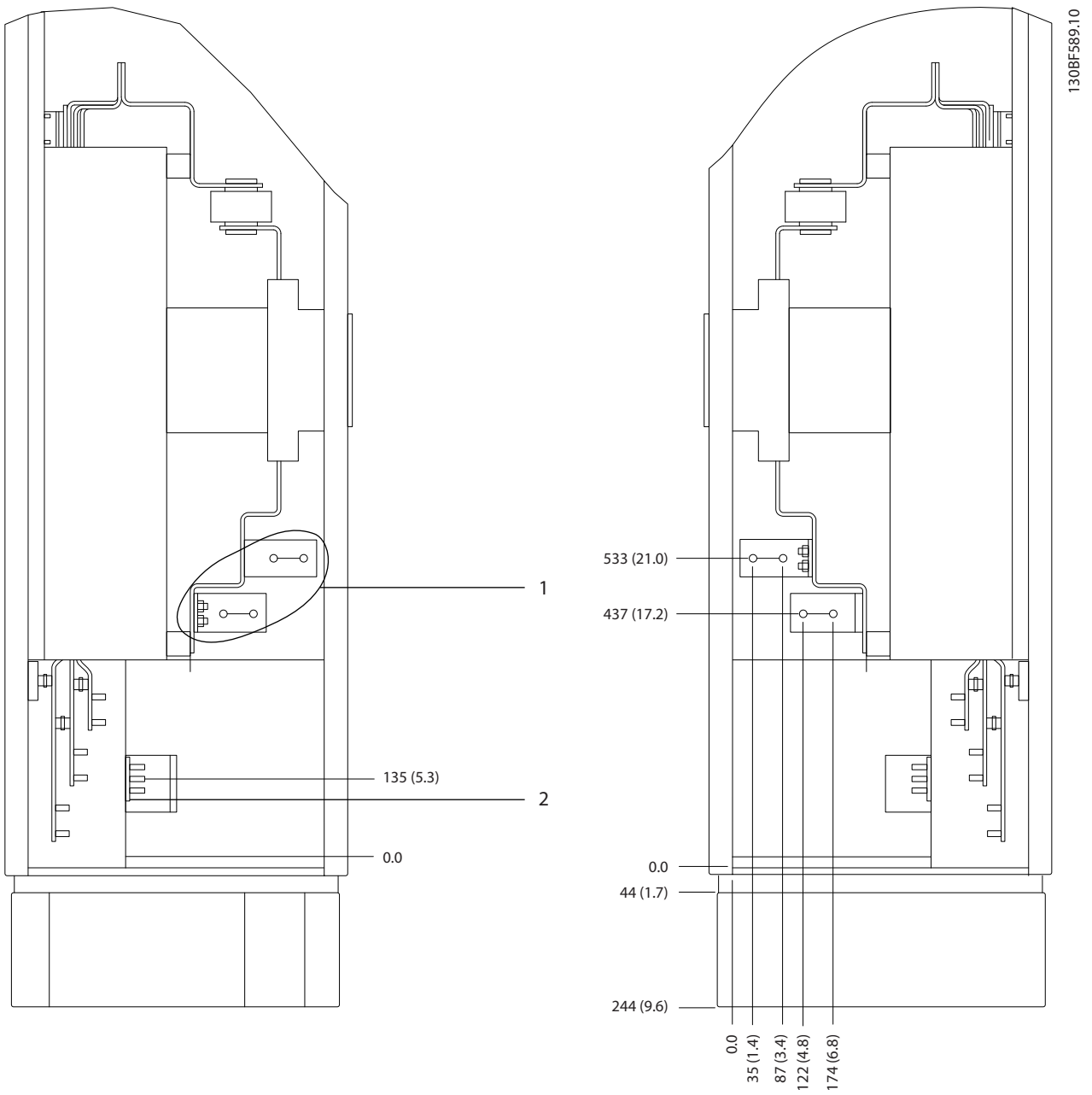

1	Mains terminals	2	Ground bar
---	-----------------	---	------------

Illustration 8.38 Terminal Dimensions for F3–F4 Options Cabinet with Circuit Breaker/Molded Case Switch (380–480/500 V Models: P450; 525–690 V Models: P630–P710), Side View



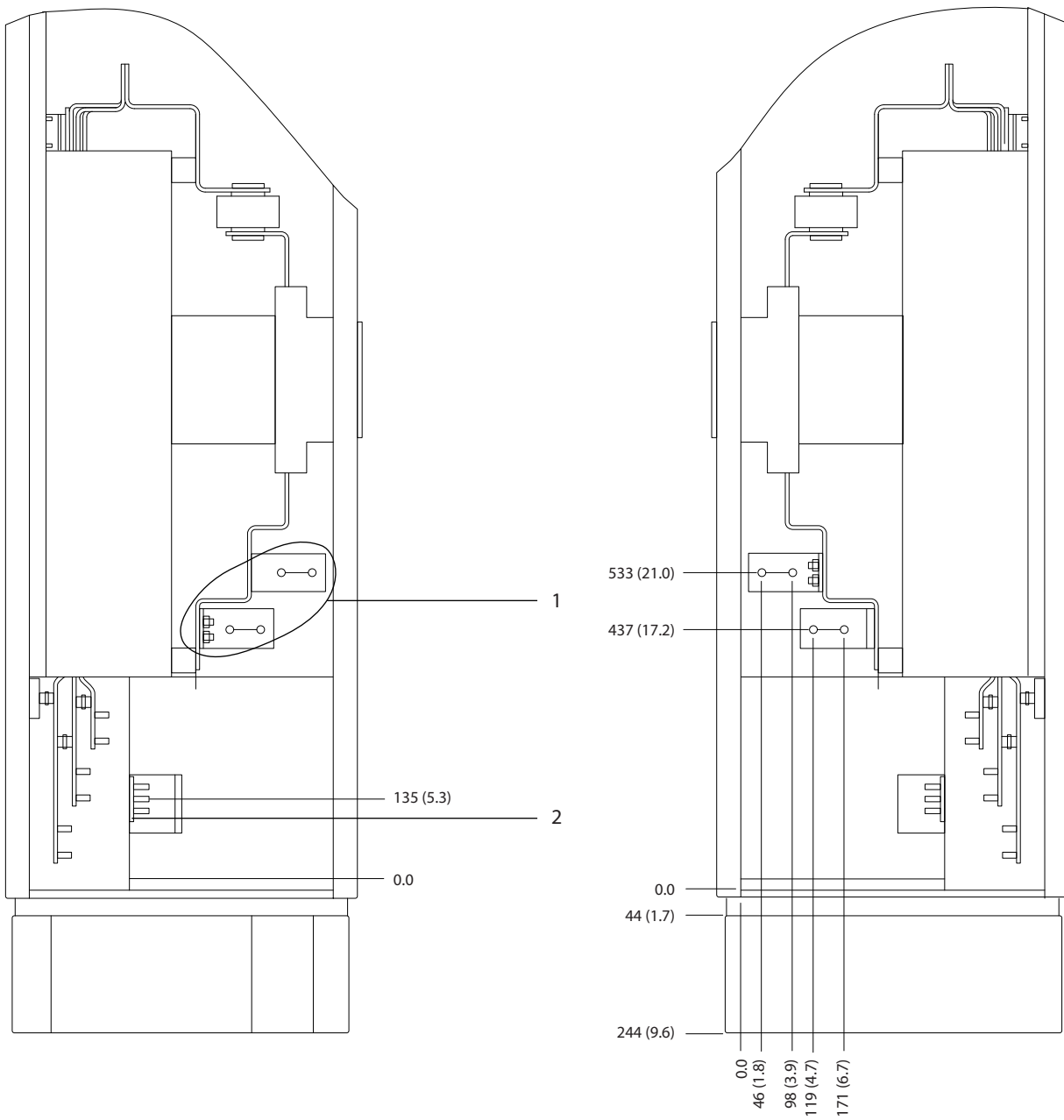

1	Mains terminals	2	Ground bar
---	-----------------	---	------------

Illustration 8.39 Terminal Dimensions for F3–F4 Options Cabinet with Circuit Breaker/Molded Case Switch (380–480/500 V Models: P500–P630; 525–690 V Models: P800), Side View

8

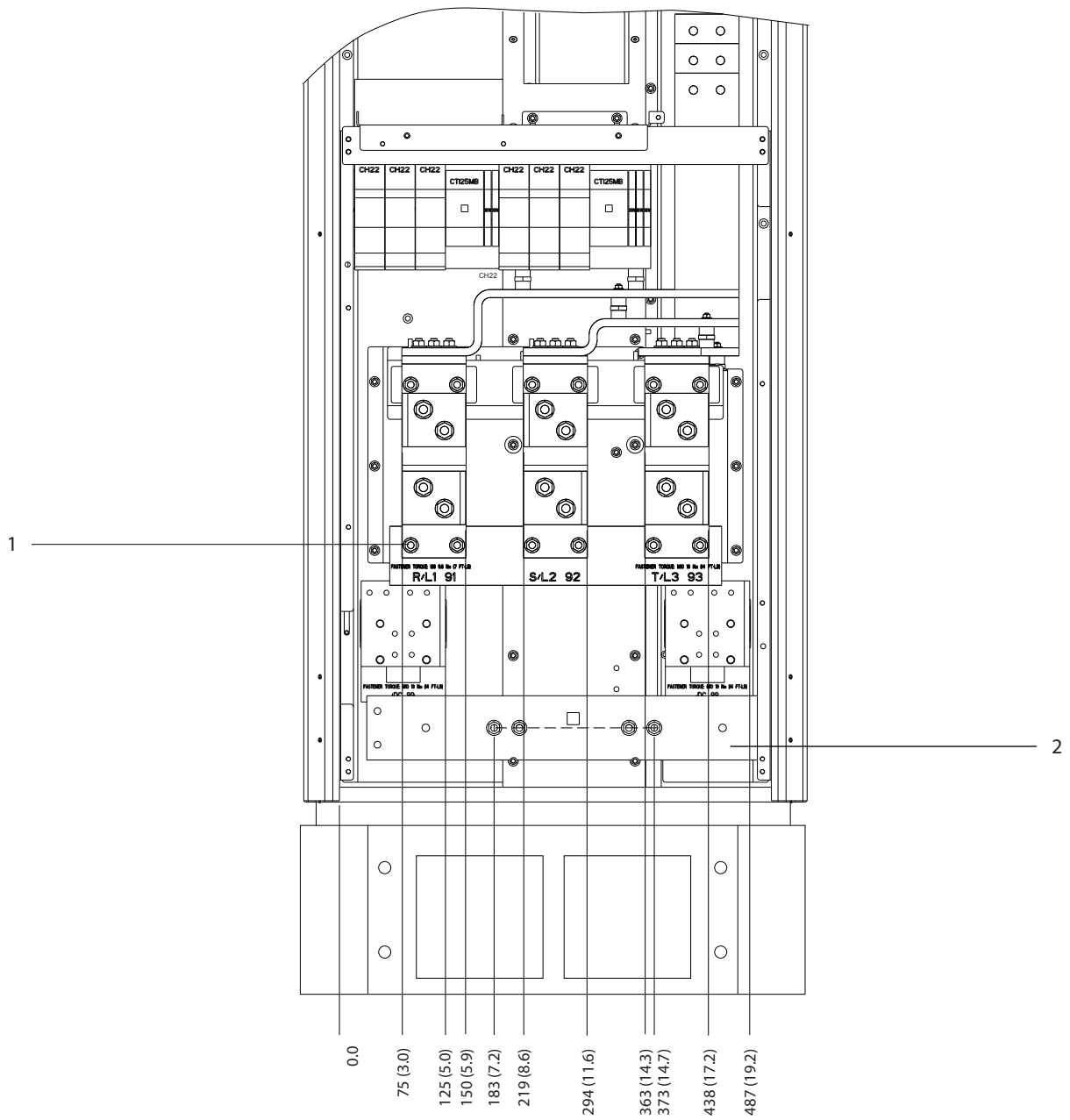

1	Mains terminals	2	Ground bar
---	-----------------	---	------------

Illustration 8.40 Terminal Dimensions for F1-F4 Rectifier Cabinet, Front View

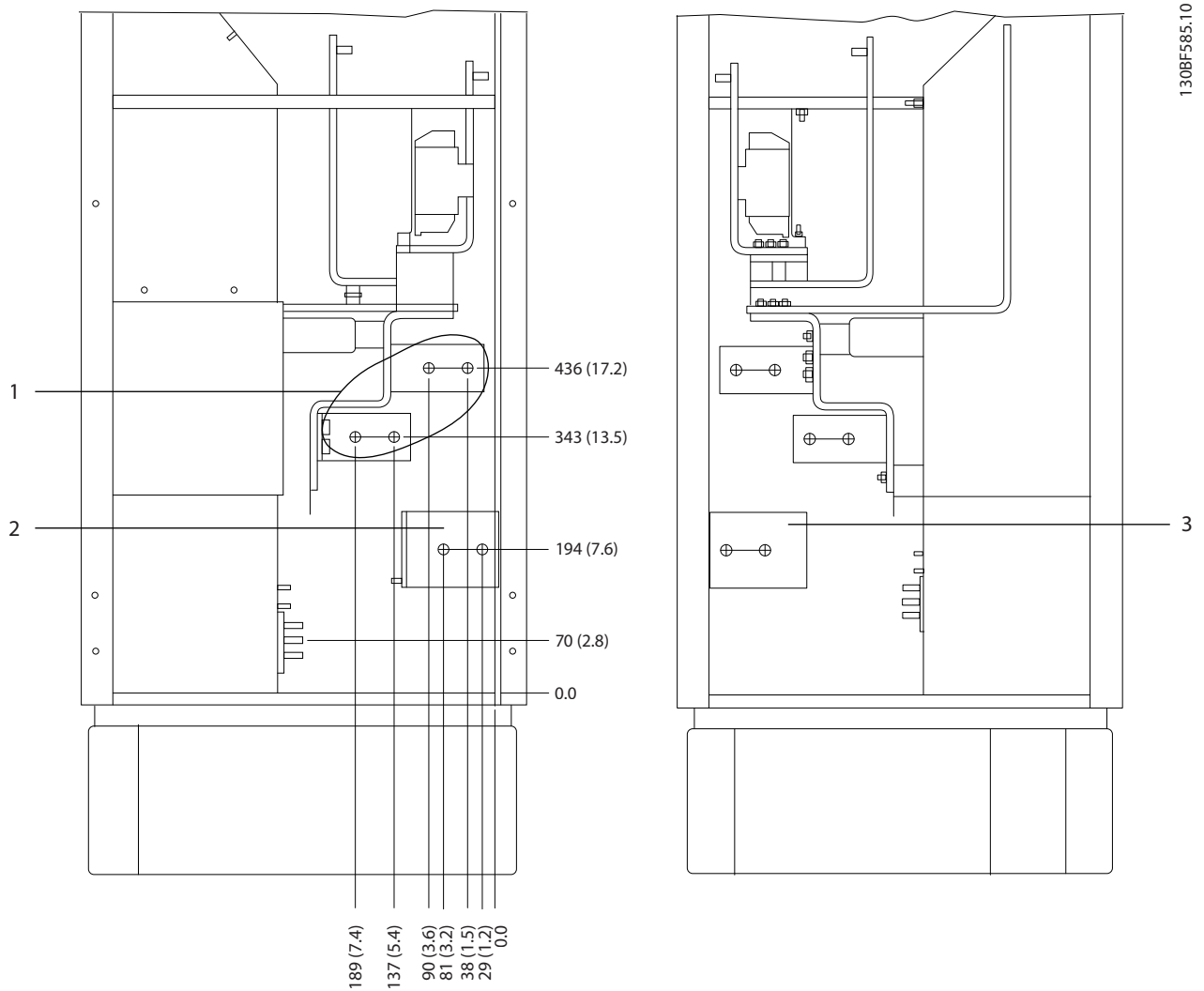

1	Mains terminals	3	Load share terminals (-)
2	Load share terminals (+)	-	-

Illustration 8.41 Terminal Dimensions for F3-F4 Rectifier Cabinet, Side View

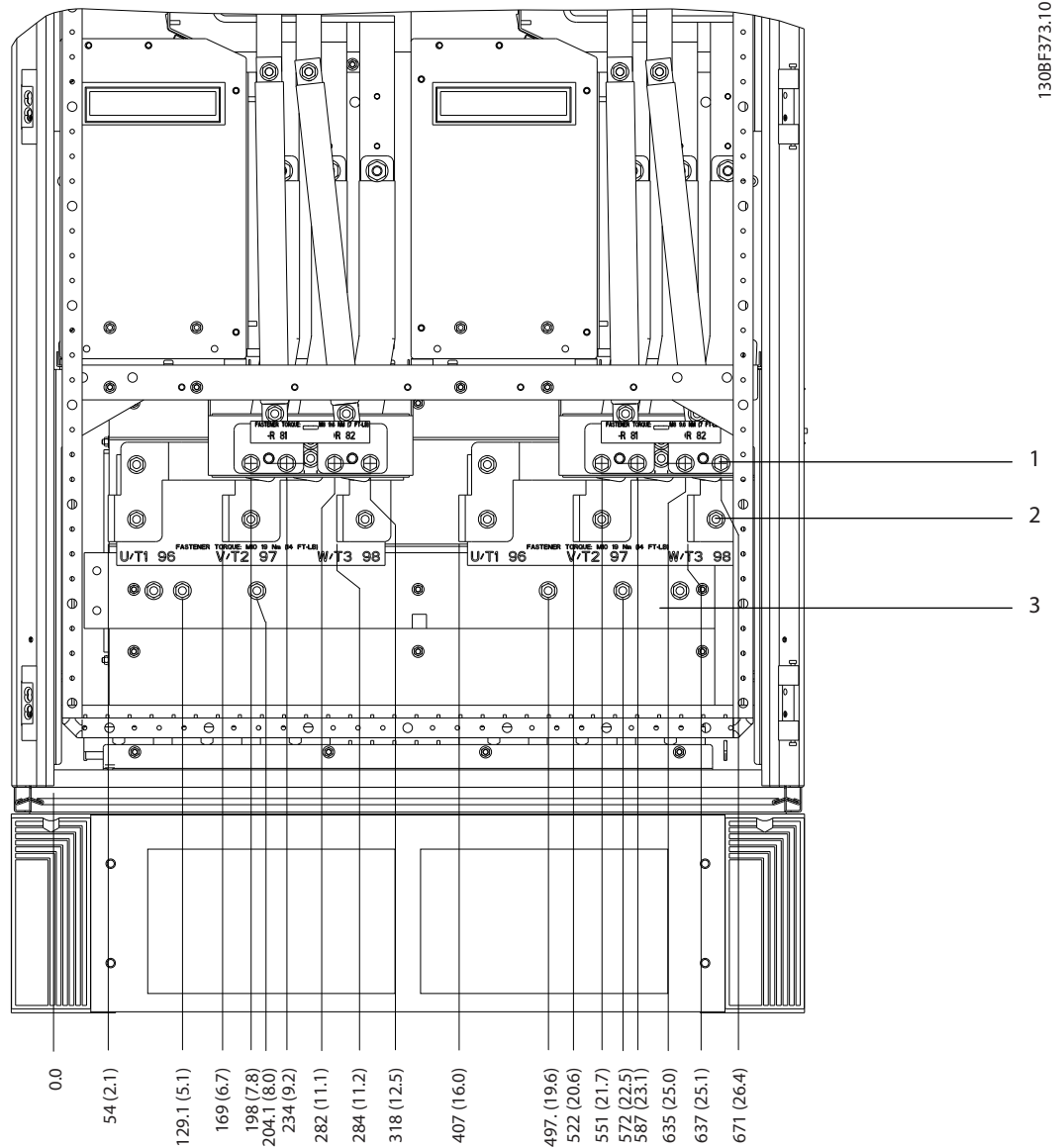

1	Brake terminals	3	Ground bar
2	Motor terminals	-	-

Illustration 8.42 Terminal Dimensions for F1/F3 Inverter Cabinet, Front View

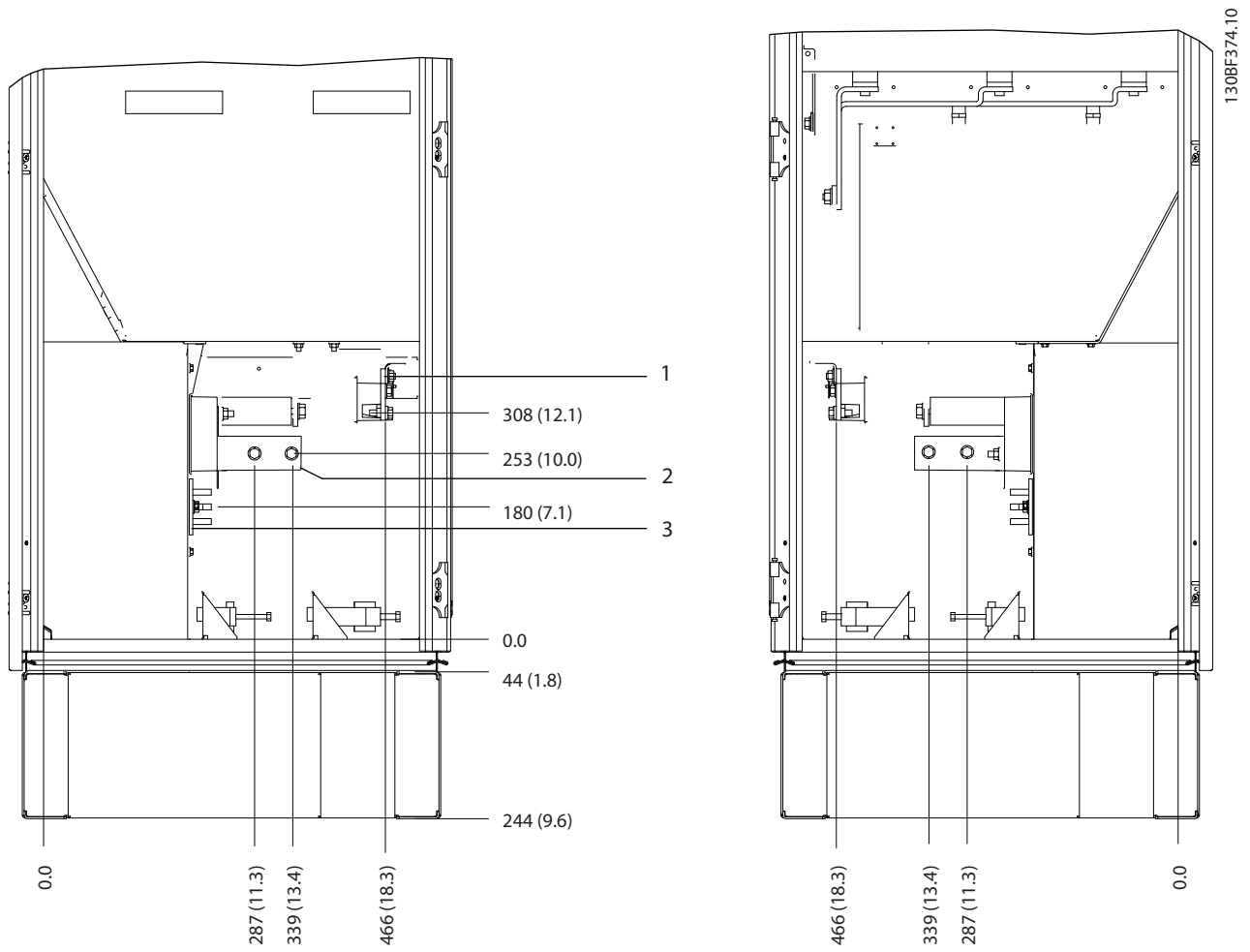

8

1	Brake terminals	3	Ground bar
2	Motor terminals	-	-

Illustration 8.43 Terminal Dimensions for F1/F3 Inverter Cabinet, Side View



## 8.6 F4 Exterior and Terminal Dimensions

### 8.6.1 F4 Exterior Dimensions

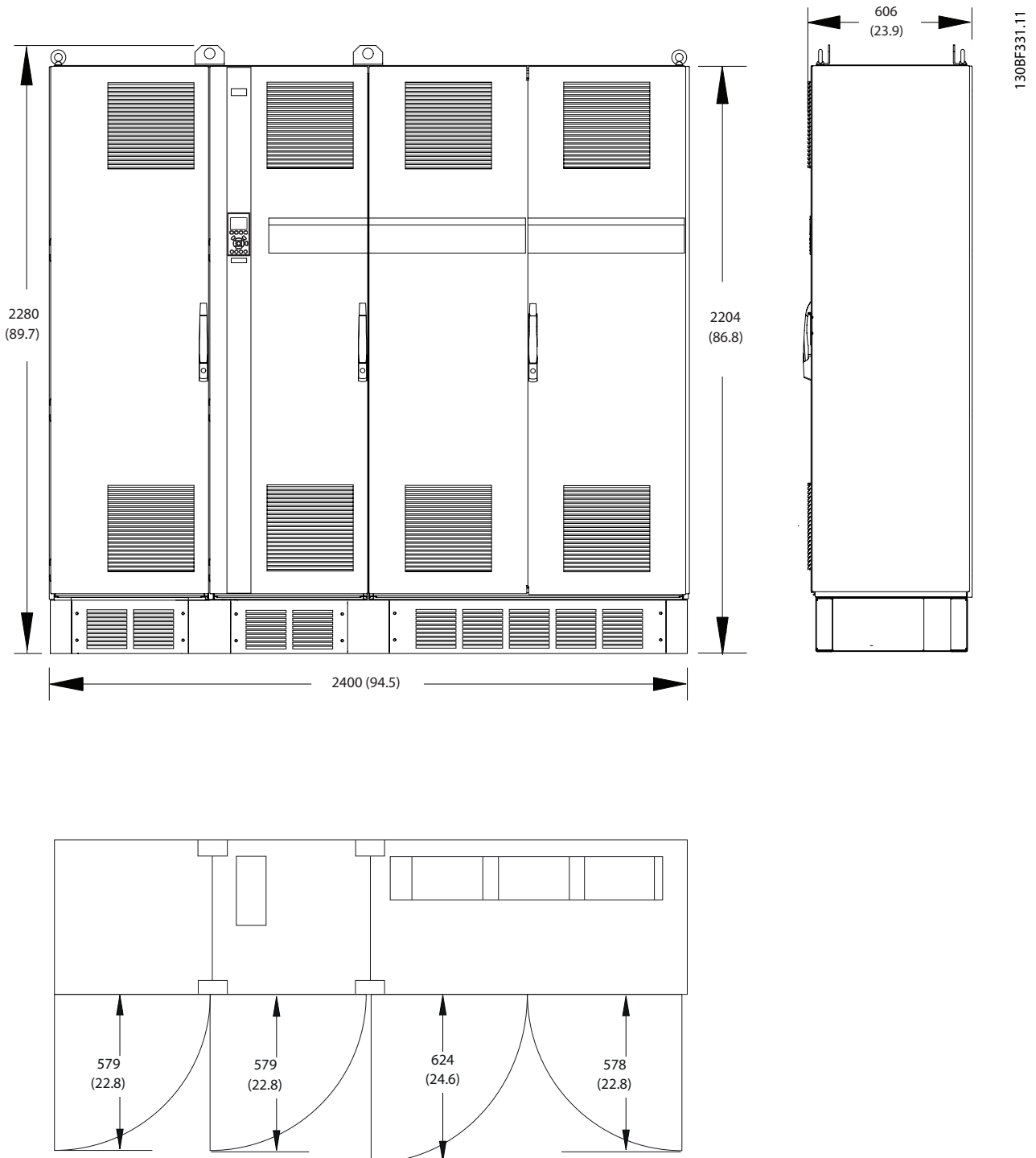

8

Illustration 8.45 Front, Side, and Door Clearance Dimensions for F4

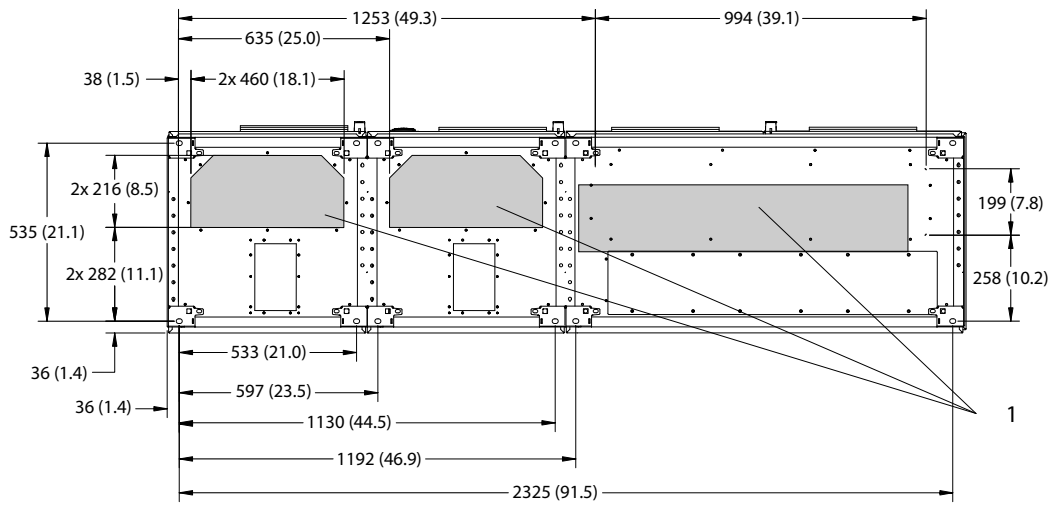

1.30BF615.10

1	Mains side	2	Motor side
---	------------	---	------------

Illustration 8.46 Gland Plate Dimensions for F4



### 8.6.2 F4 Terminal Dimensions

Power cables are heavy and hard to bend. To ensure easy installation of the cables, consider the optimum placement of the drive. Each terminal allows up to 4 cables with cable lugs or a standard box lug. Ground is connected to a relevant termination point in the drive.

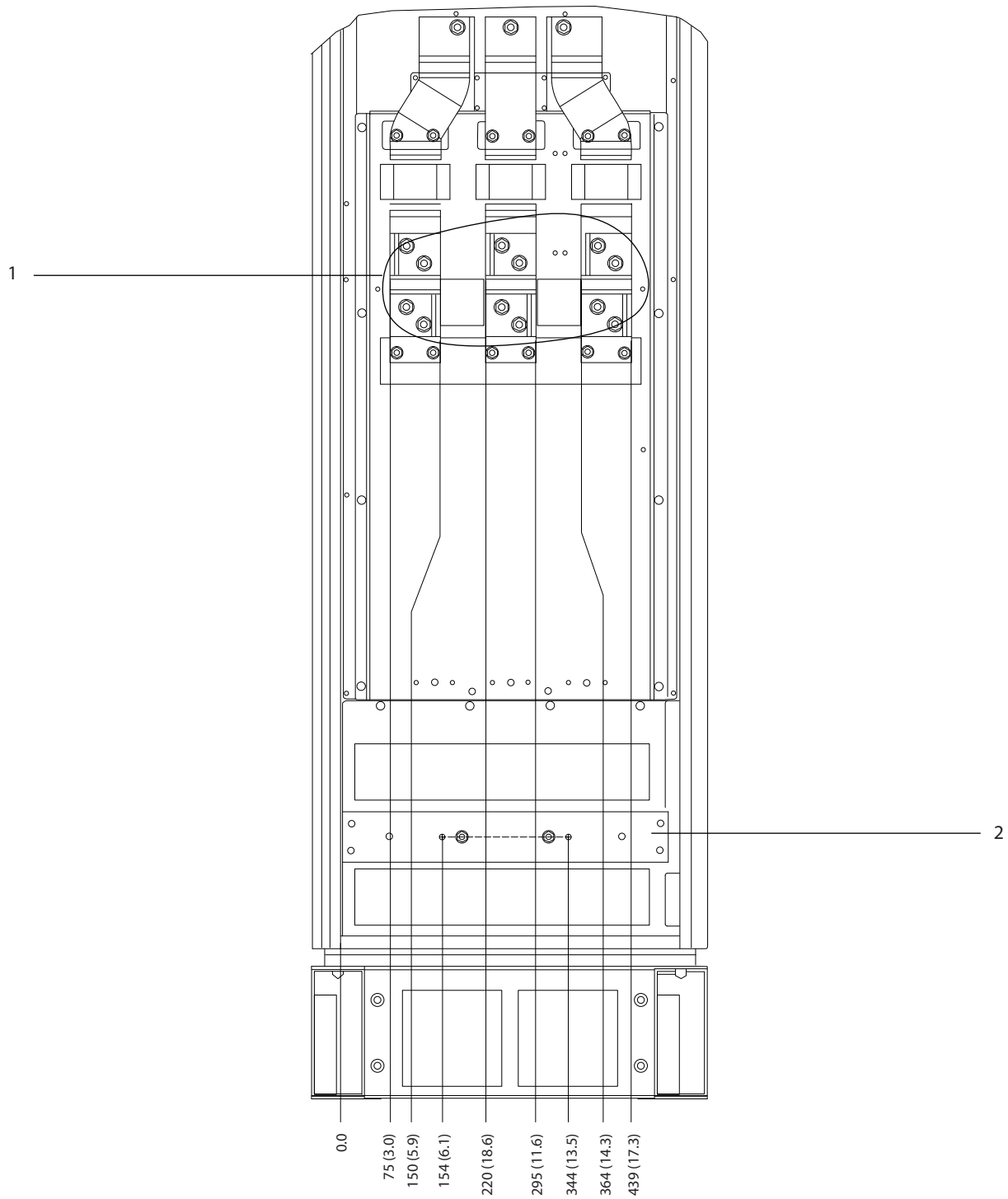

1	Mains terminals	2	Ground bar
---	-----------------	---	------------

Illustration 8.47 Terminal Dimensions for F3-F4 Options Cabinet, Front View

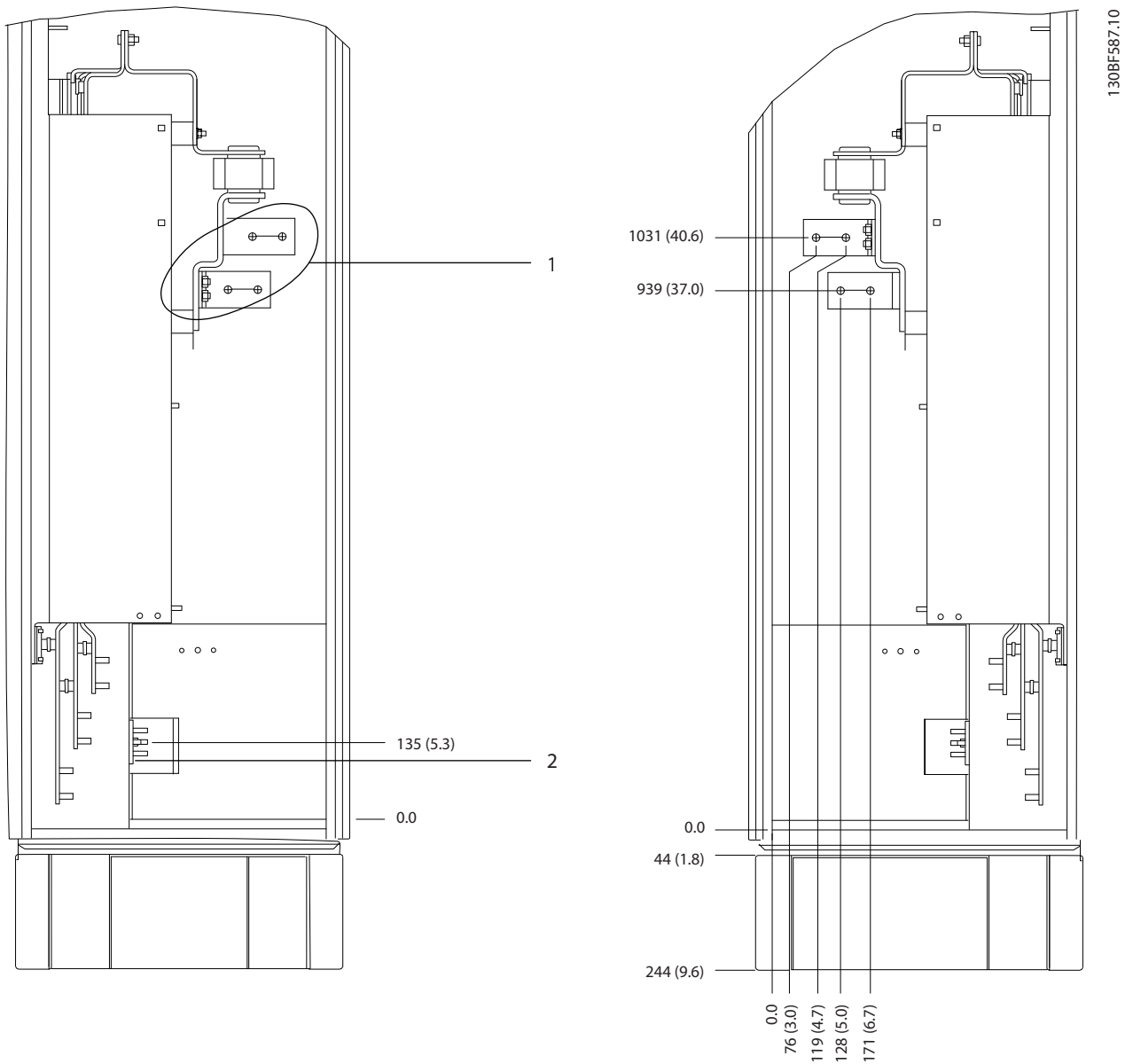

1	Mains terminals	2	Ground bar
---	-----------------	---	------------

Illustration 8.48 Terminal Dimensions for F3-F4 Options Cabinet, Side View

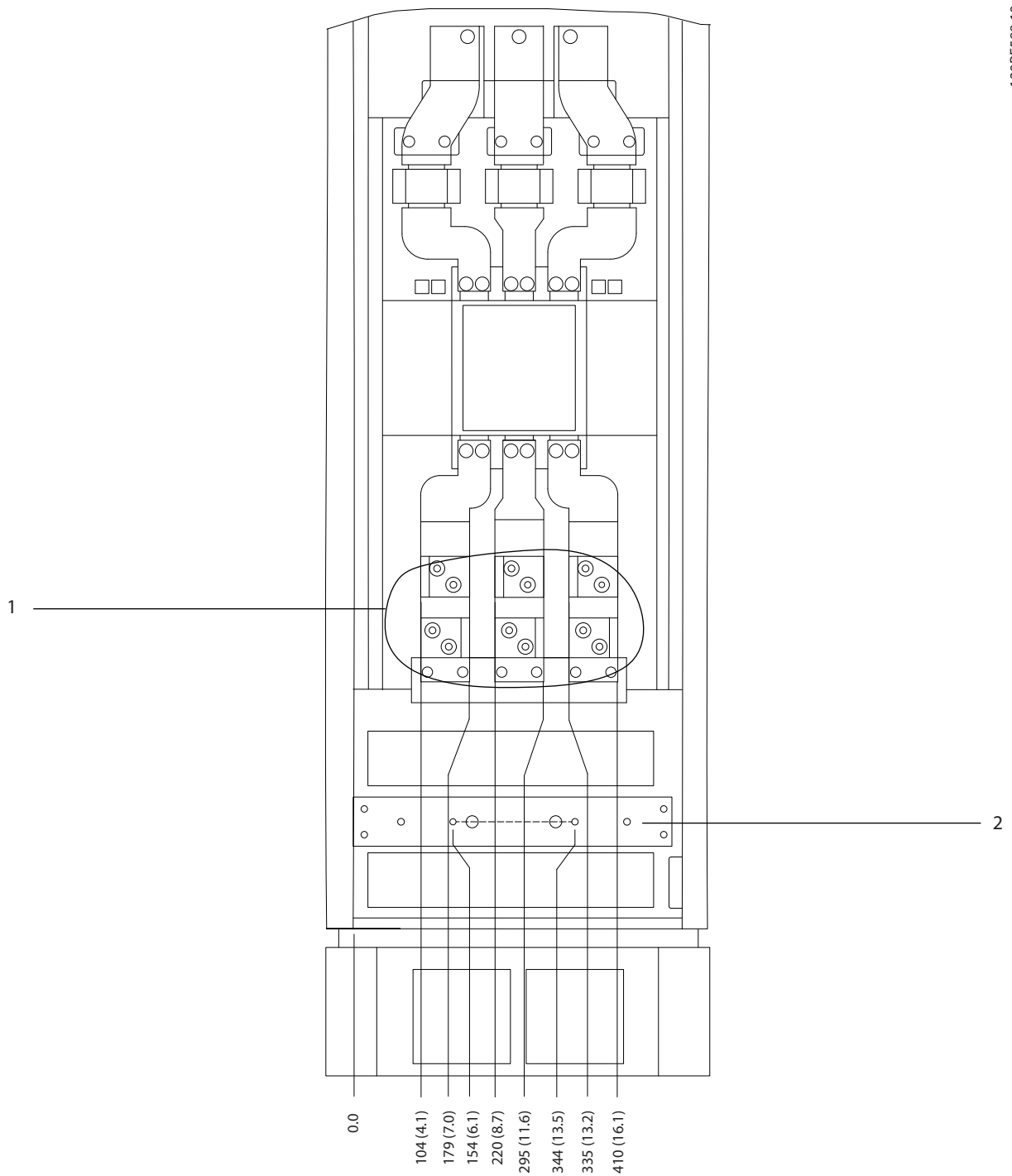

1	Mains terminals	2	Ground bar
---	-----------------	---	------------

Illustration 8.49 Terminal Dimensions for F3–F4 Options Cabinet with Circuit Breaker/Molded Case Switch, Front View

8

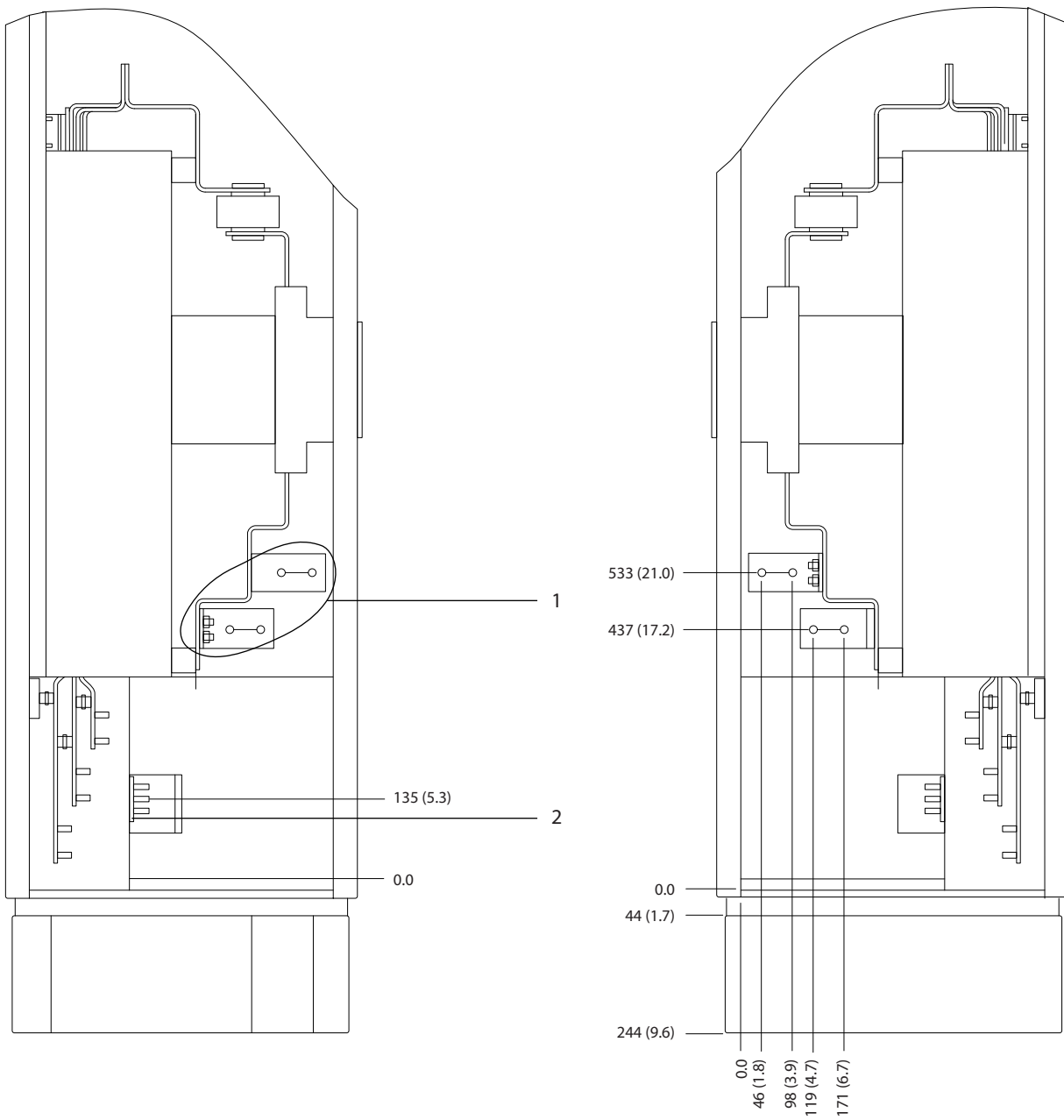

1	Mains terminals	2	Ground bar
---	-----------------	---	------------

Illustration 8.50 Terminal Dimensions for F3-F4 Options Cabinet with Circuit Breaker/Molded Case Switch, Side View

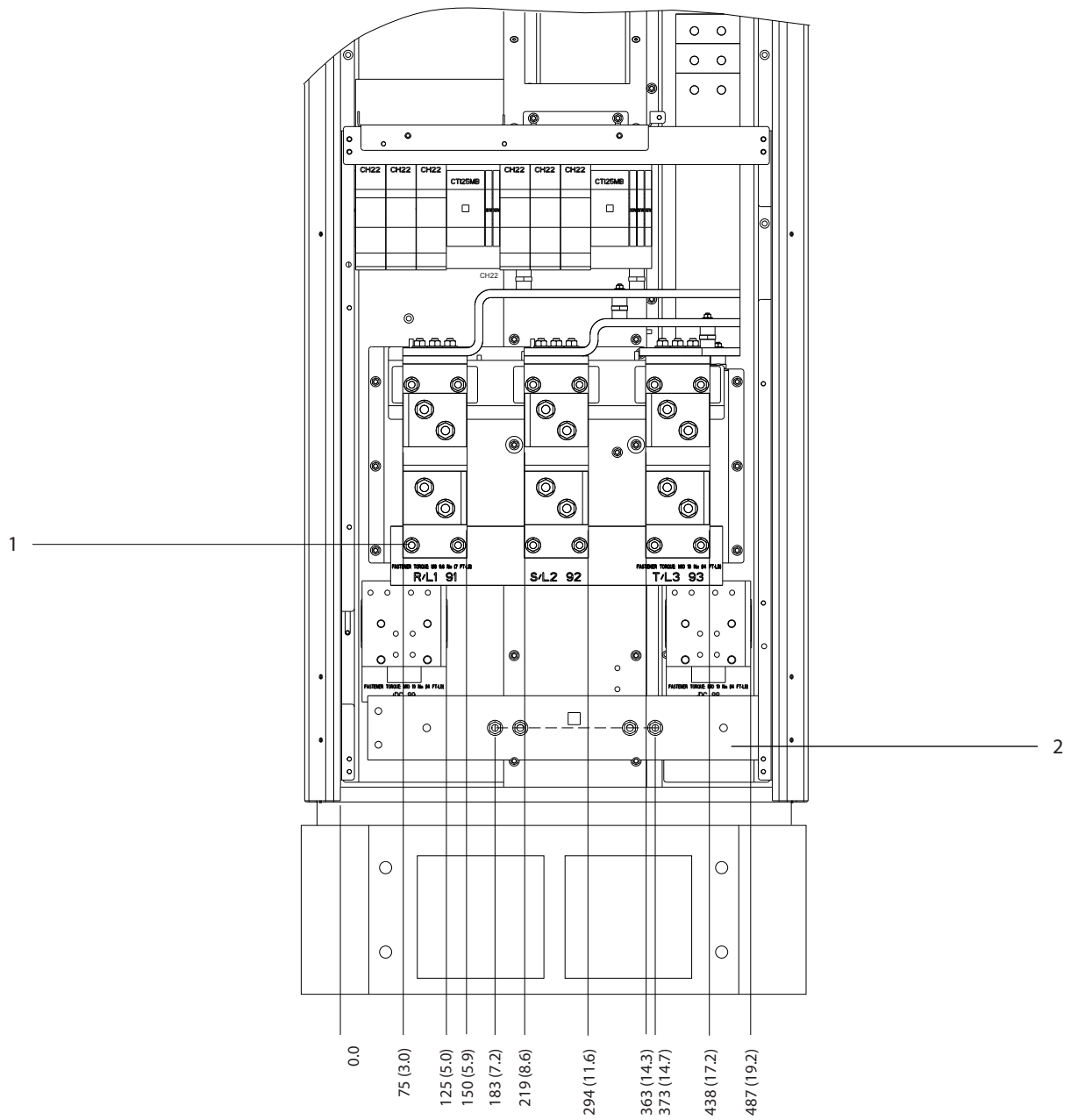

1	Mains terminals	2	Ground bar
---	-----------------	---	------------

Illustration 8.51 Terminal Dimensions for F1-F4 Rectifier Cabinet, Front View

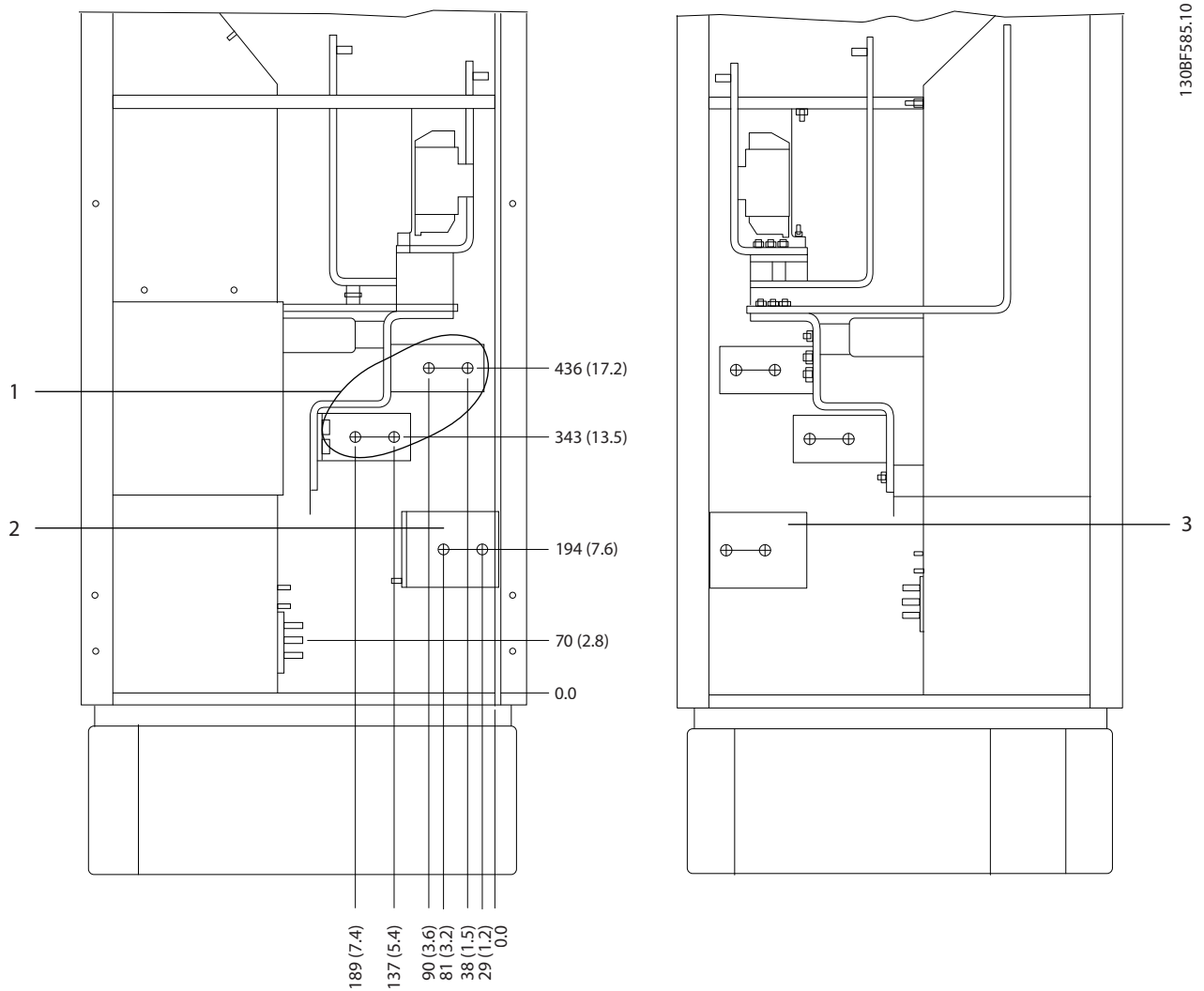

1	Mains terminals	3	Load share terminals (-)
2	Load share terminals (+)	-	-

Illustration 8.52 Terminal Dimensions for F3-F4 Rectifier Cabinet, Side View

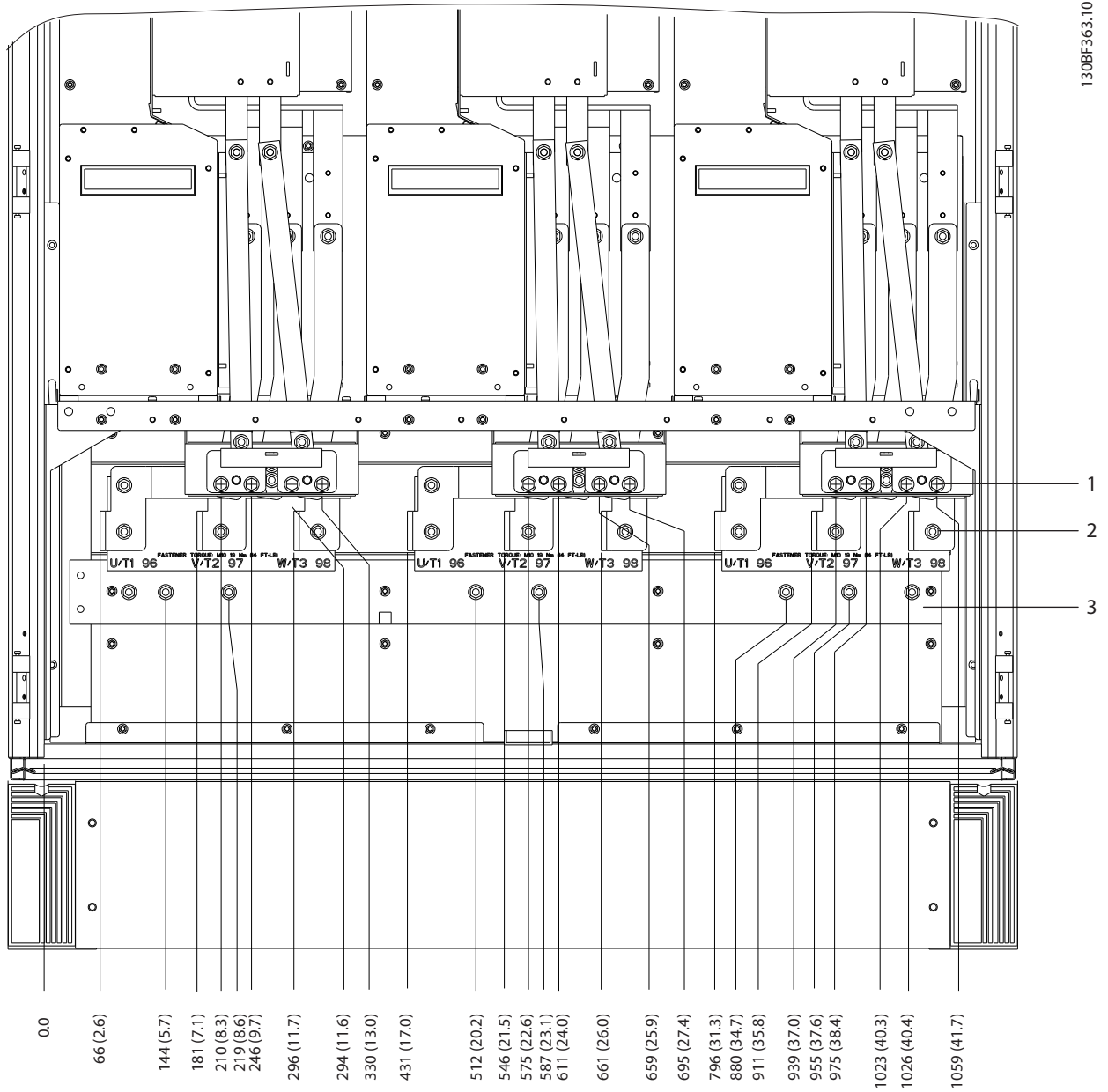

1	Brake terminals	3	Ground bar
2	Motor terminals	-	-

Illustration 8.53 Terminal Dimensions for F2/F4 Inverter Cabinet, Front View

8

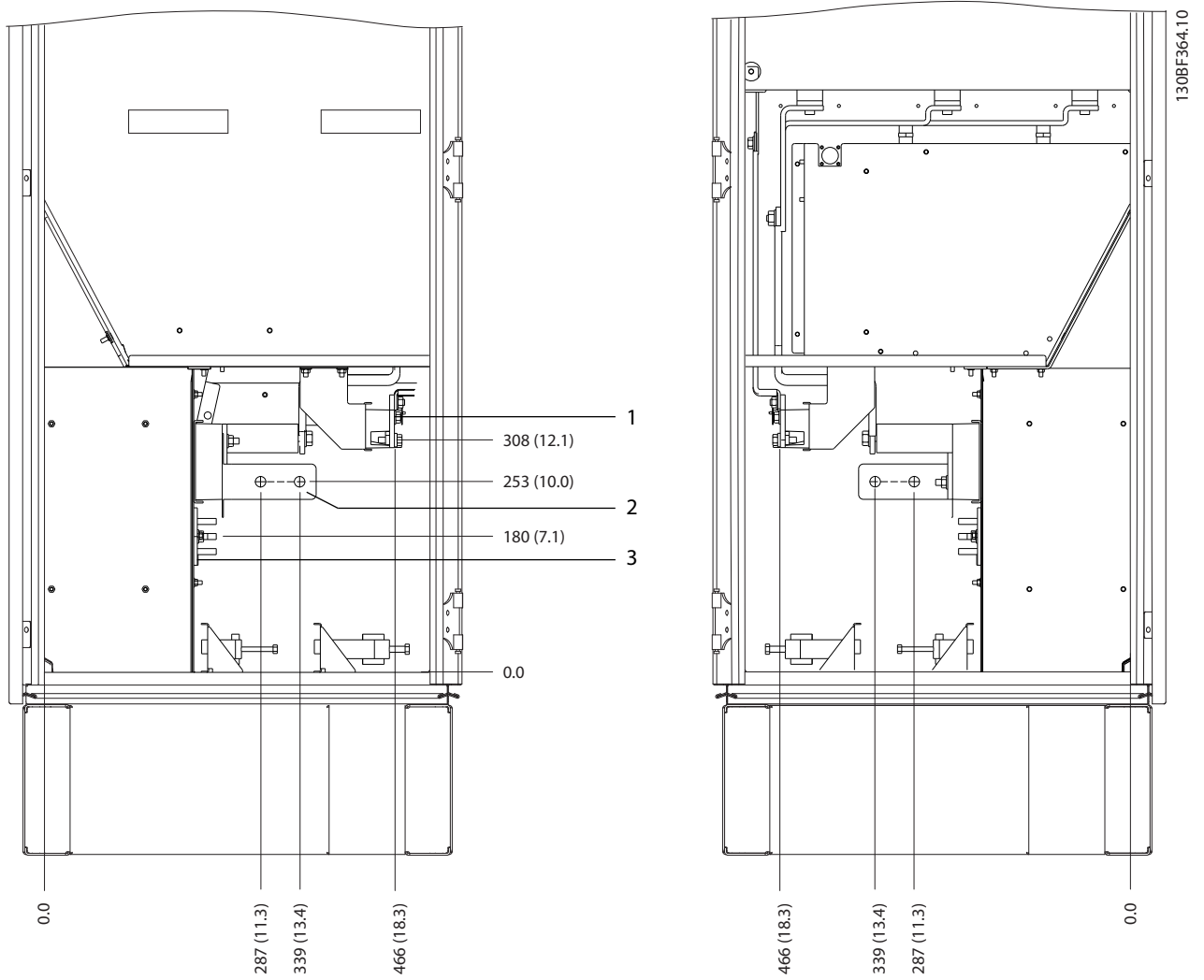

1	Brake terminals	3	Ground bar
2	Motor terminals	-	-

Illustration 8.54 Terminal Dimensions for F2/F4 Inverter Cabinet, Side View



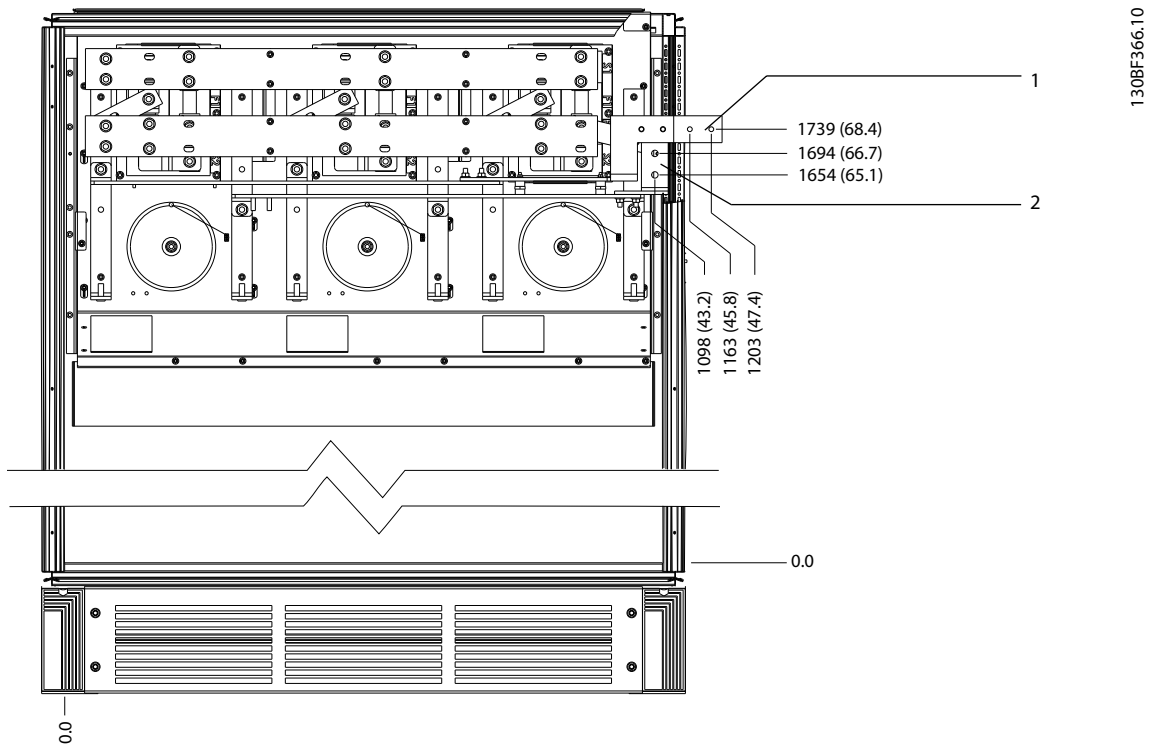

Illustration 8.55 Terminal Dimensions for F2/F4 Regeneration Terminals, Front View

8.7 F8 Exterior and Terminal Dimensions

8.7.1 F8 Exterior Dimensions

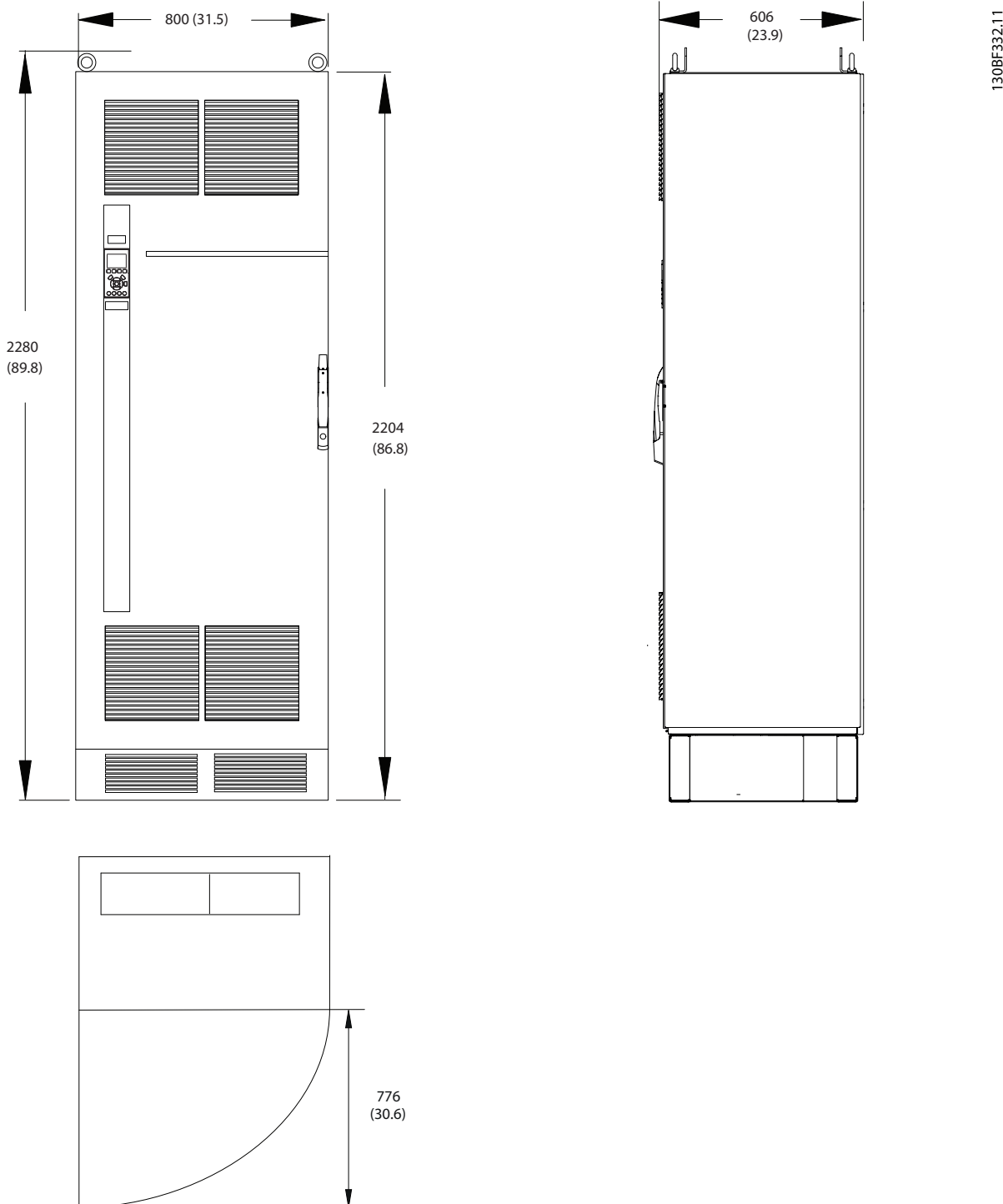
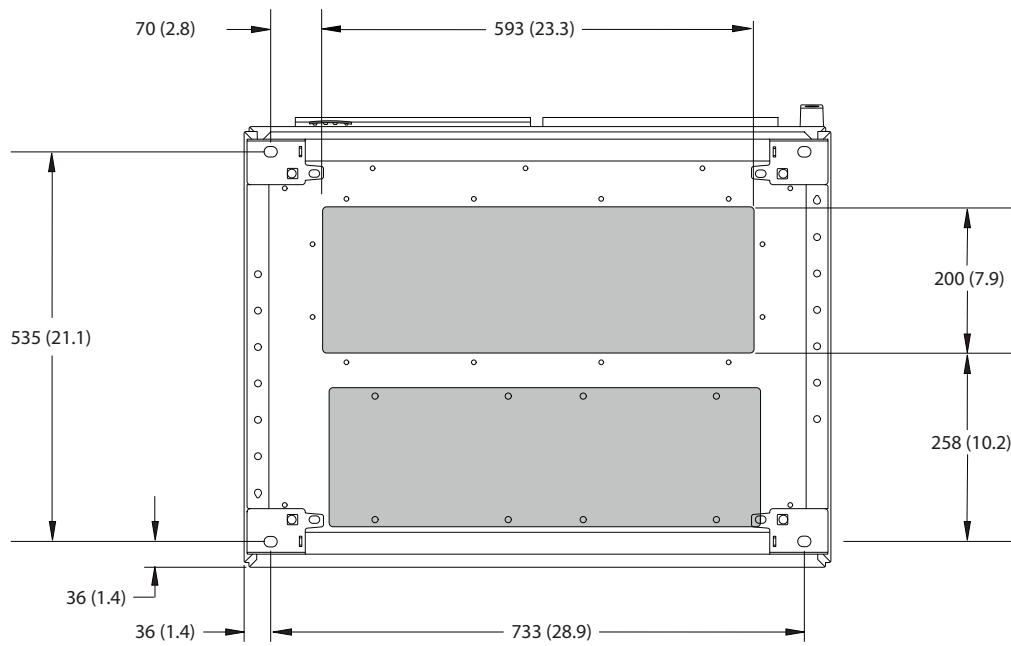

Illustration 8.56 Front, Side, and Door Clearance Dimensions for F8



1	Mains side	2	Motor side
---	------------	---	------------

Illustration 8.57 Gland Plate Dimensions for F8

### 8.7.2 F8 Terminal Dimensions

Power cables are heavy and hard to bend. To ensure easy installation of the cables, consider the optimum placement of the drive. Each terminal allows up to 4 cables with cable lugs or a standard box lug. Ground is connected to a relevant termination point in the drive.

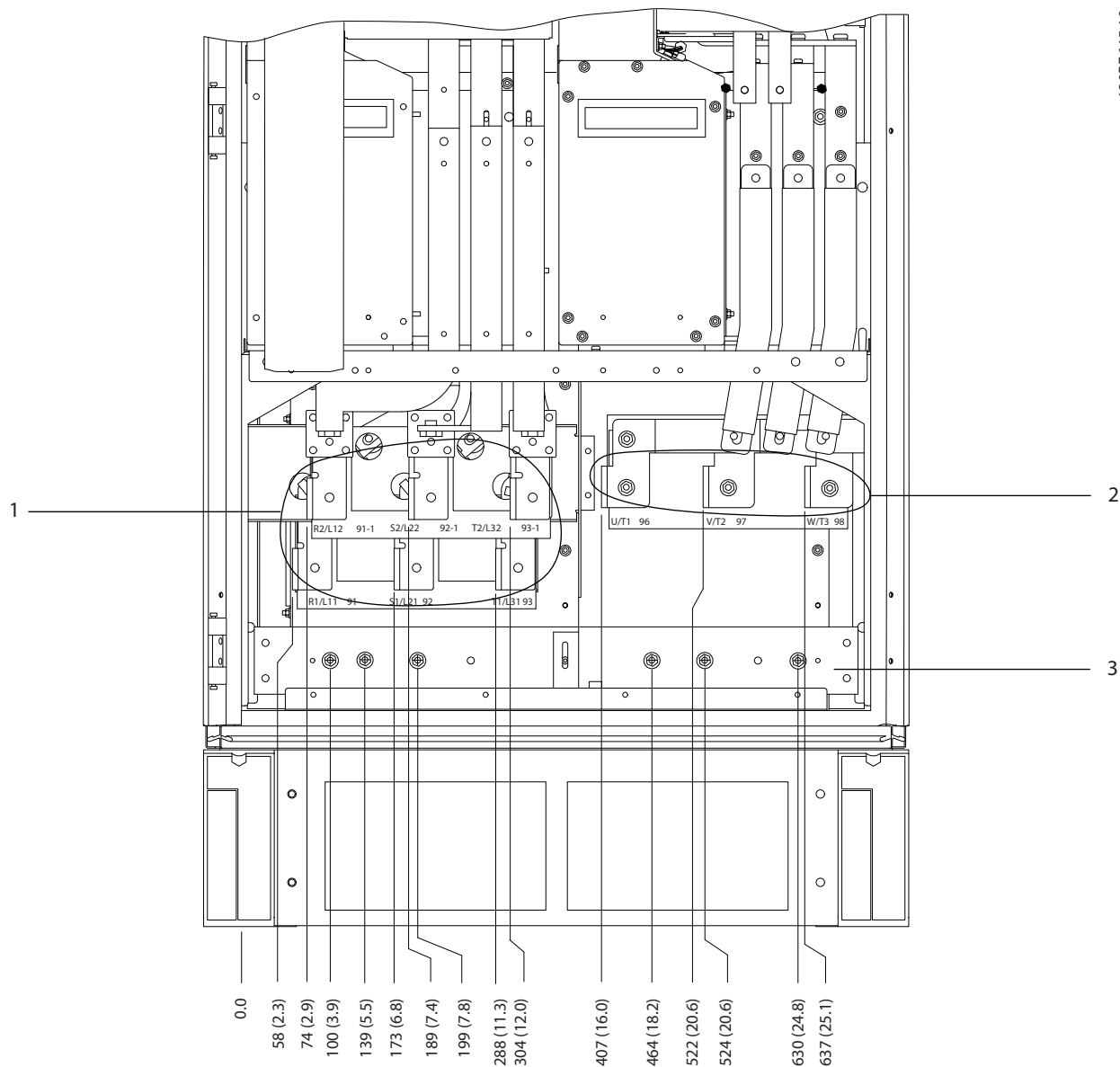

1	Mains terminals	3	Ground bar
2	Motor terminals	-	-

Illustration 8.58 Terminal Dimensions for F8–F9 Rectifier/Inverter Cabinet, Front View

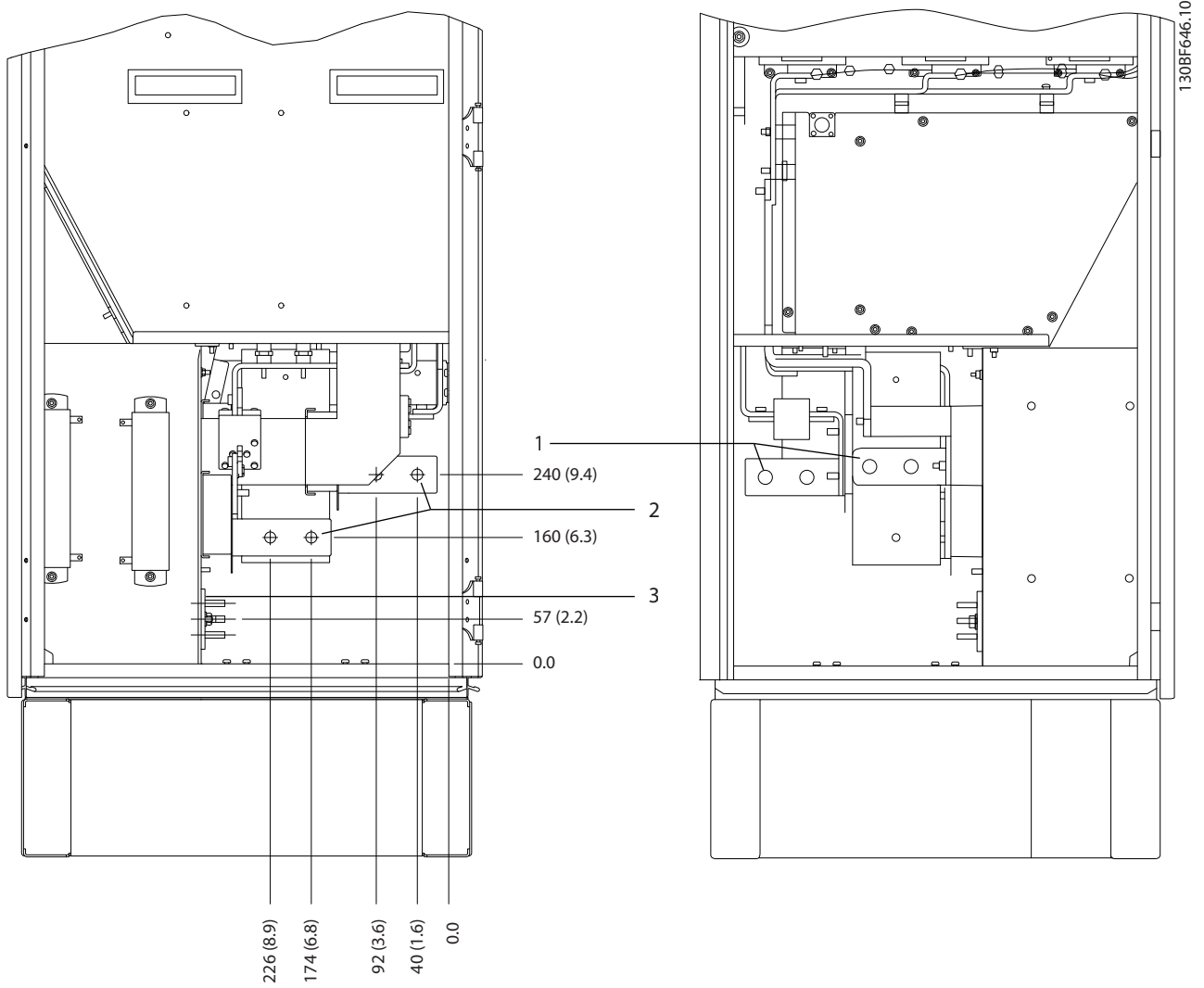

8

Illustration 8.59 Terminal Dimensions for F8-F9 Rectifier/Inverter Cabinet, Side View

8.8 F9 Exterior and Terminal Dimensions

8.8.1 F9 Exterior Dimensions

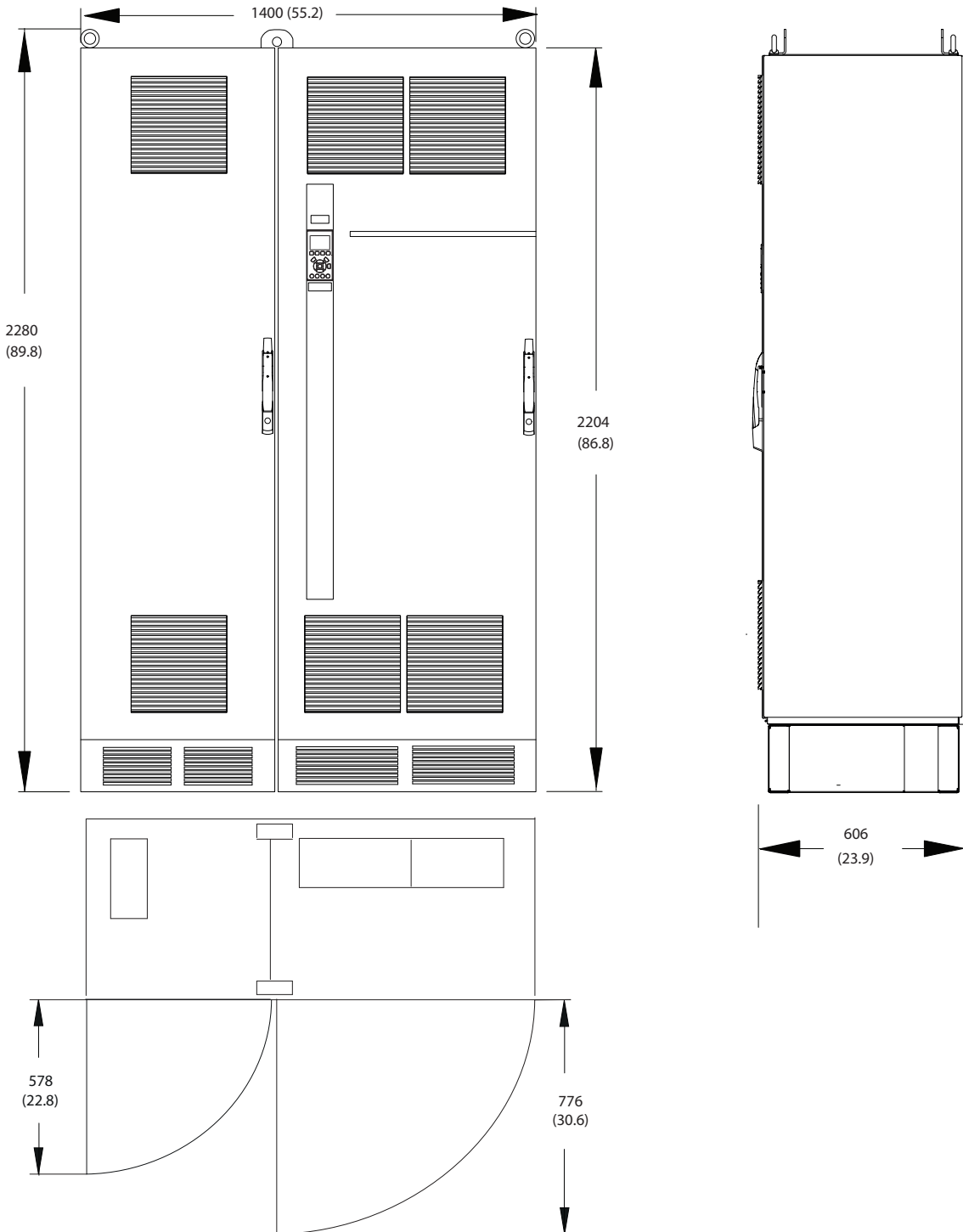

130BF333.10

8

Illustration 8.60 Front, Side, and Door Clearance Dimensions for F9

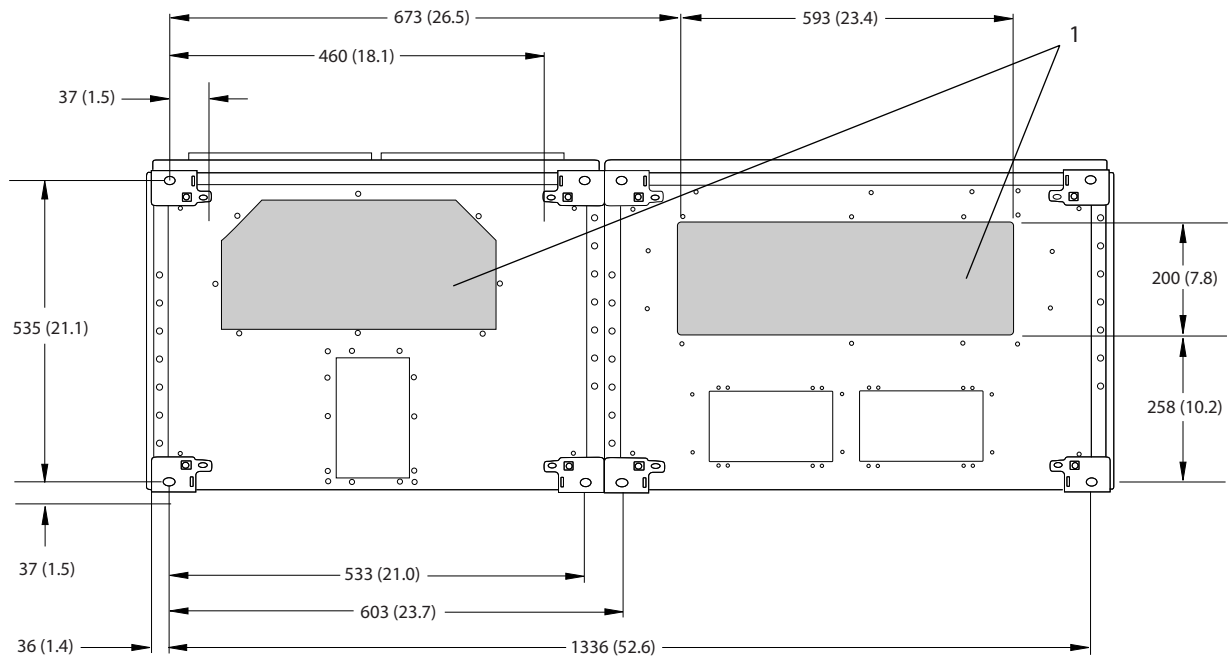

130BF617.10

1	Mains side	2	Motor side
---	------------	---	------------

Illustration 8.61 Gland Plate Dimensions for F9

### 8.8.2 F9 Terminal Dimensions

Power cables are heavy and hard to bend. To ensure easy installation of the cables, consider the optimum placement of the drive. Each terminal allows up to 4 cables with cable lugs or a standard box lug. Ground is connected to a relevant termination point in the drive.

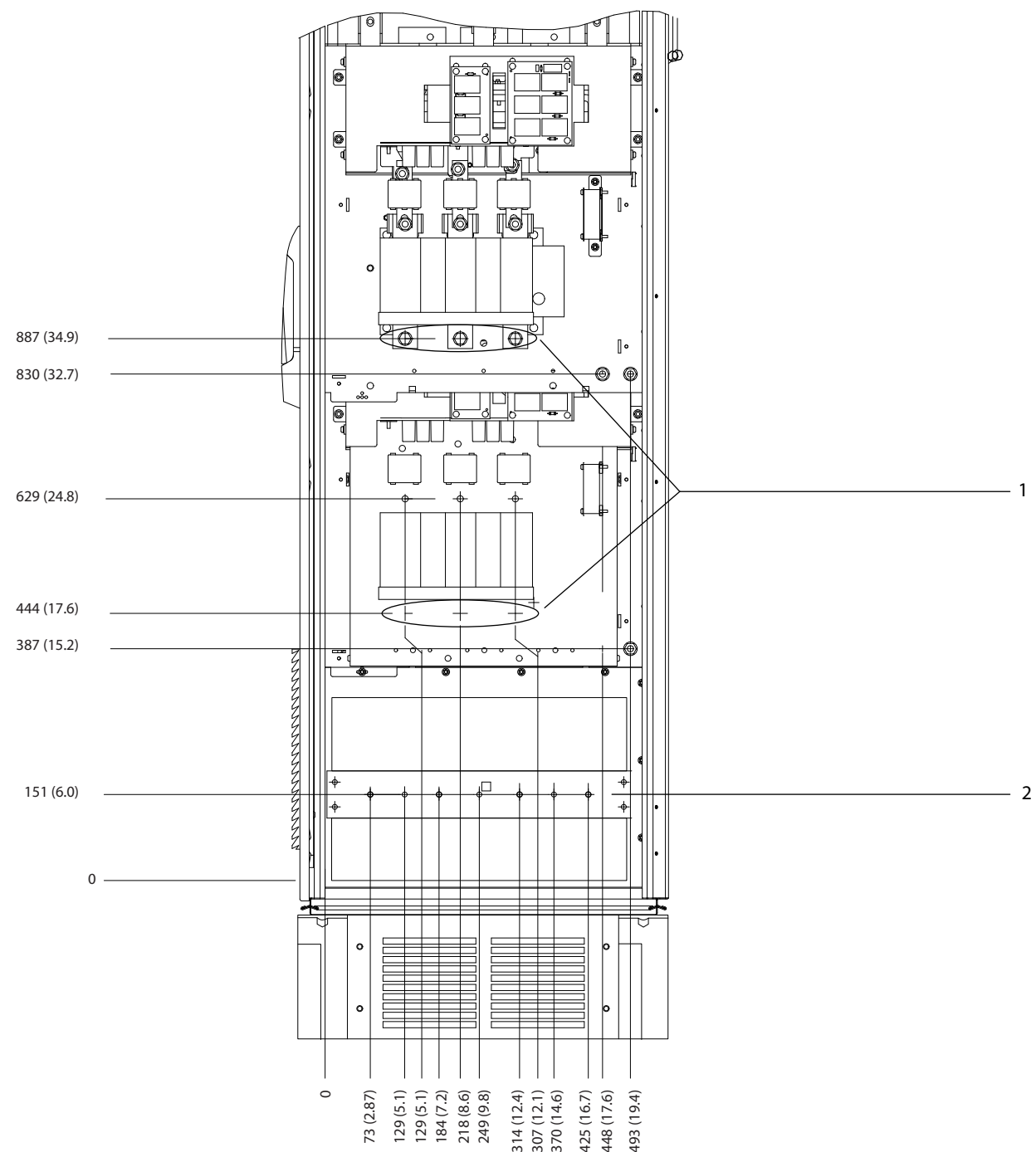

1 30BF579.10

1	Mains terminals	2	Ground bar
---	-----------------	---	------------

Illustration 8.62 Terminal Dimensions for F9 Options Cabinet, Front View



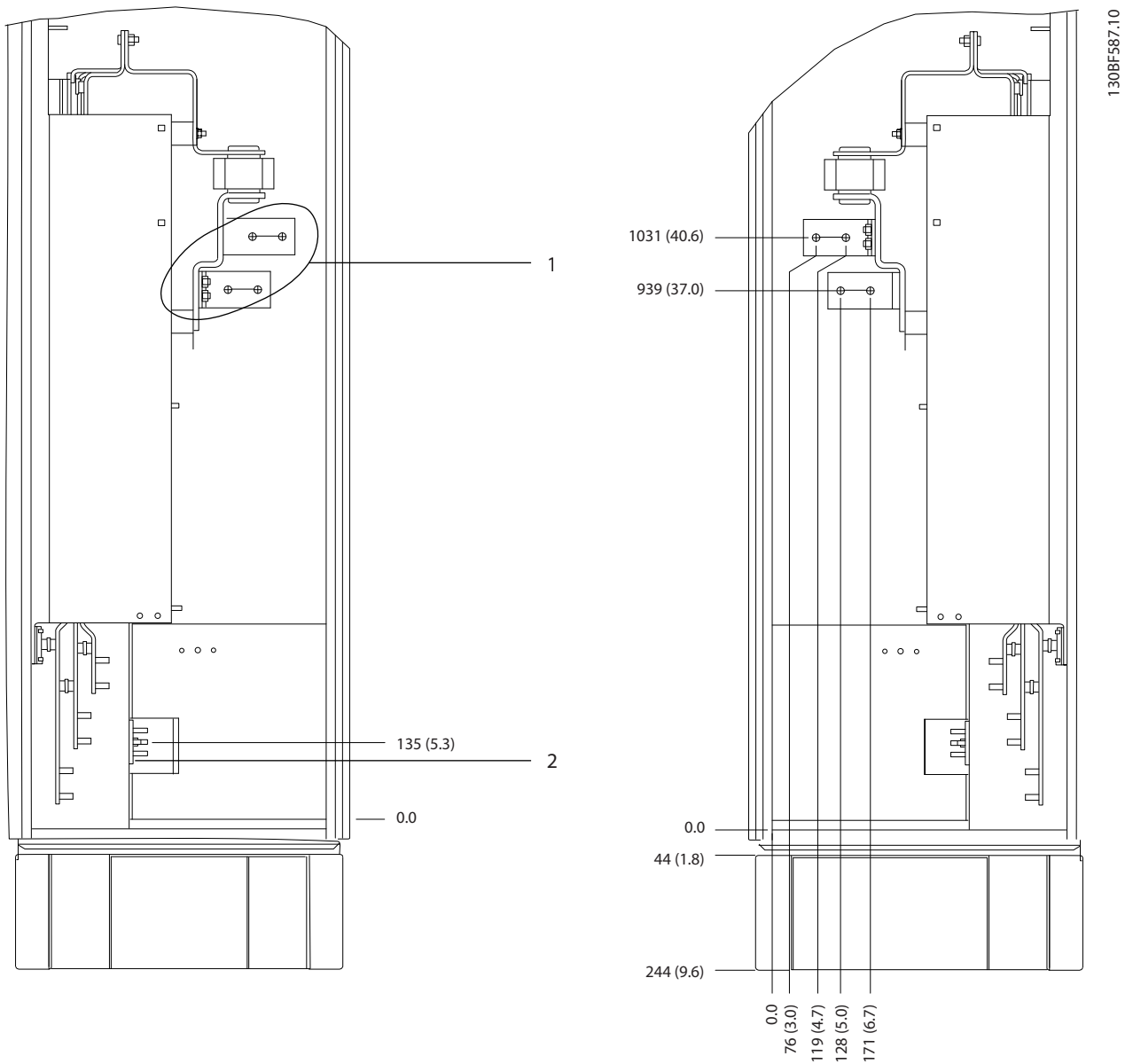
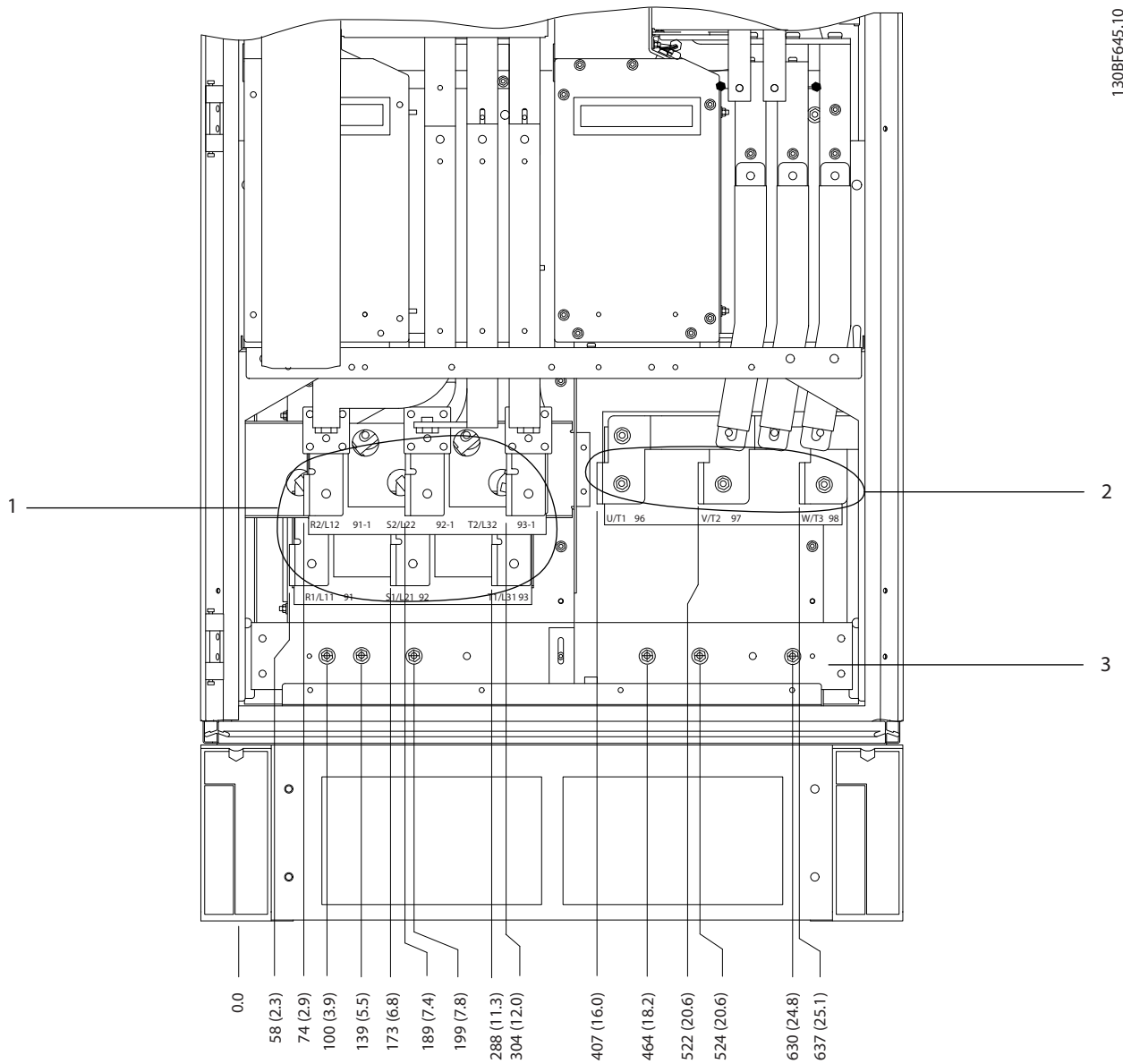

Illustration 8.63 Terminal Dimensions for F9 Options Cabinet, Side View



130BF645.10

8

1	Mains terminals	3	Ground bar
2	Motor terminals	-	-

Illustration 8.64 Terminal Dimensions for F8-F9 Rectifier/Inverter Cabinet, Front View

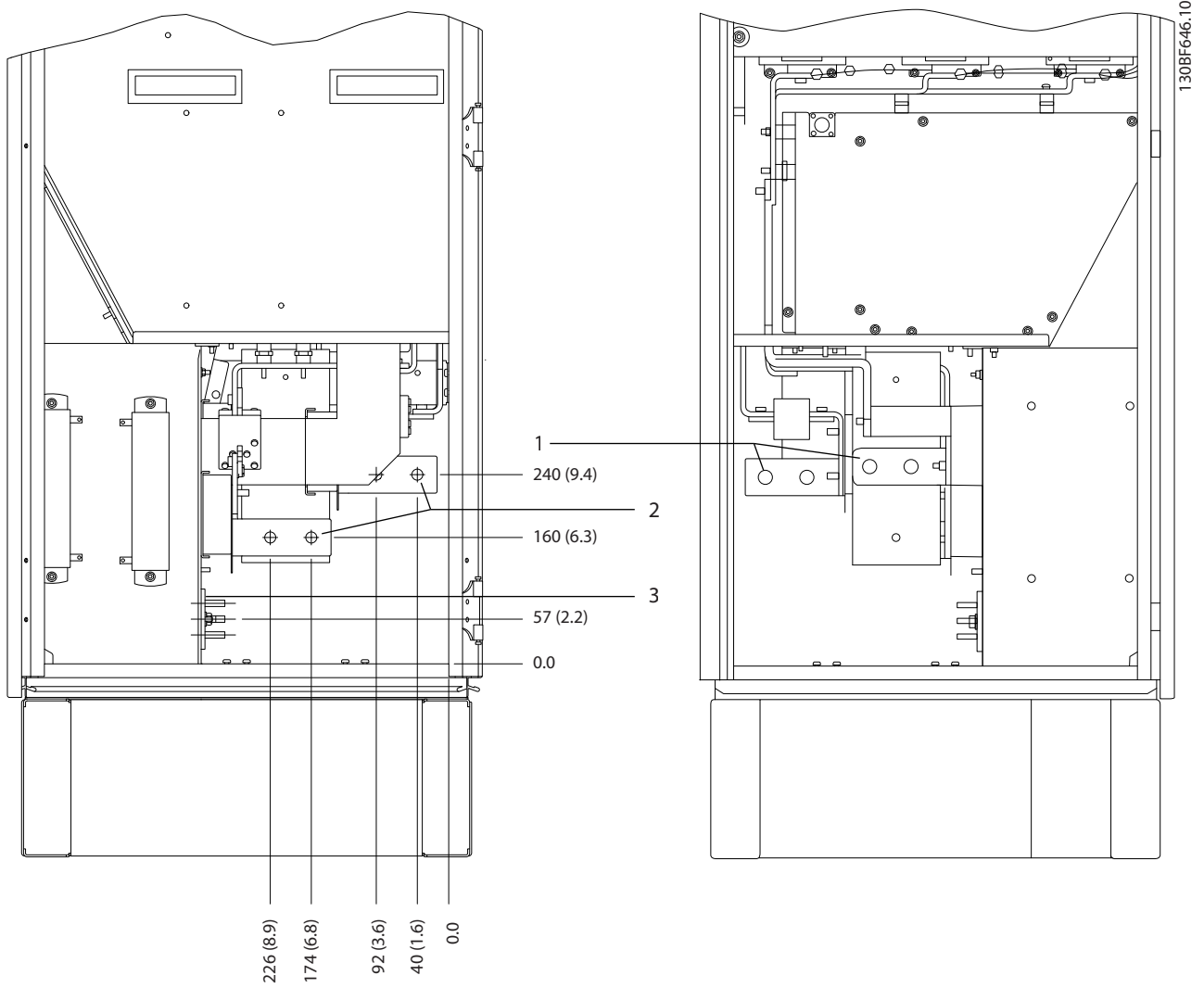

8

Illustration 8.65 Terminal Dimensions for F8-F9 Rectifier/Inverter Cabinet, Side View

8.9 F10 Exterior and Terminal Dimensions

8.9.1 F10 Exterior Dimensions

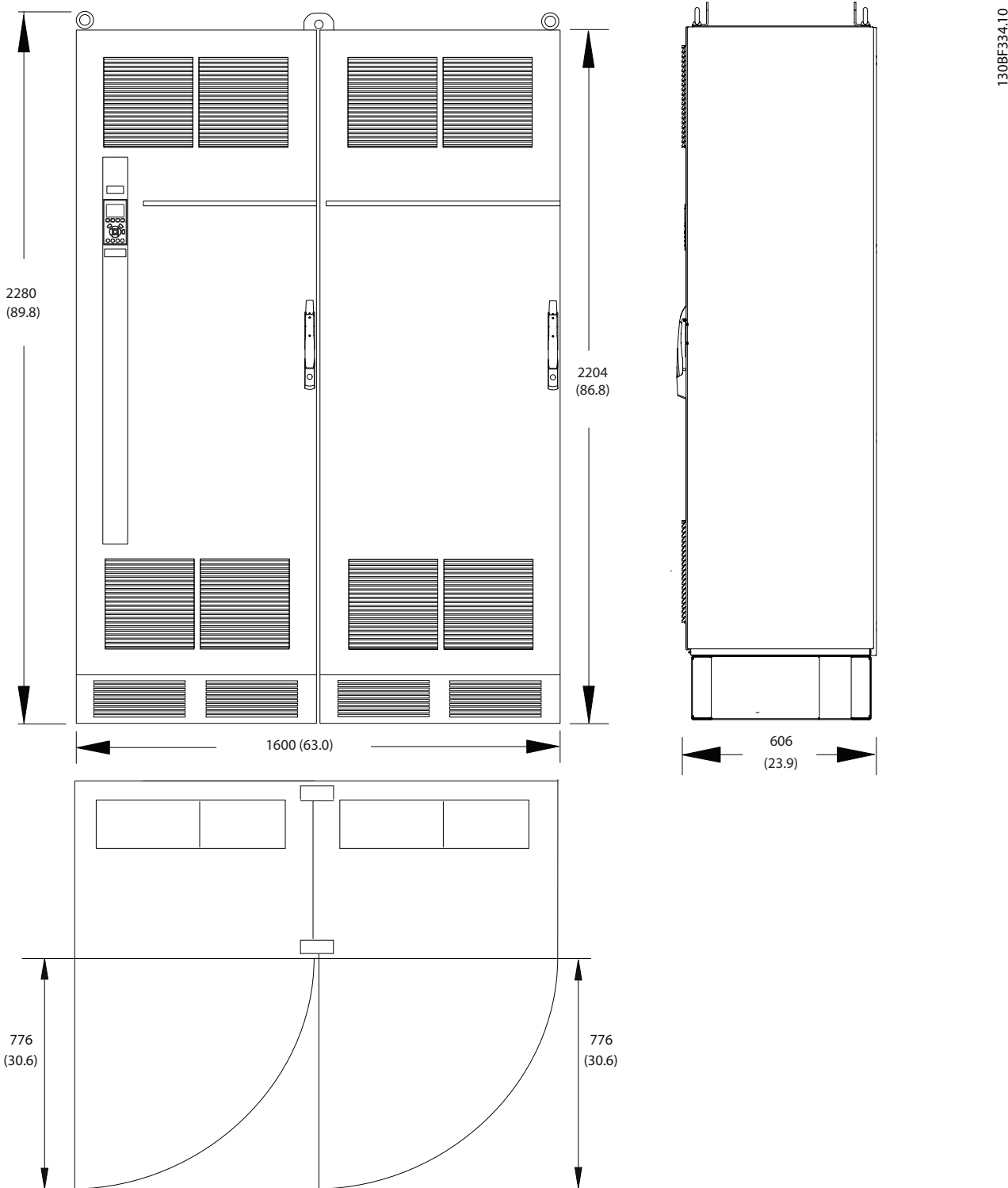

130BF334.10

8

Illustration 8.66 Front, Side, and Door Clearance Dimensions for F10

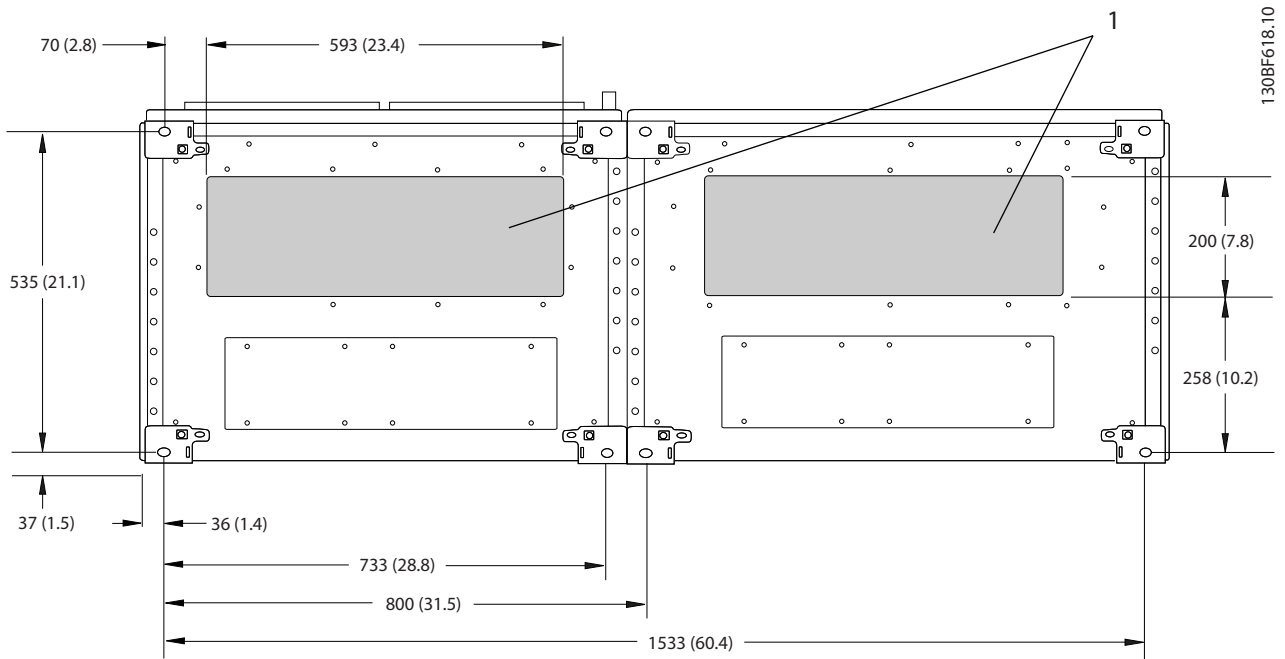

1	Mains side	2	Motor side
---	------------	---	------------

Illustration 8.67 Gland Plate Dimensions for F10

### 8.9.2 F10 Terminal Dimensions

Power cables are heavy and hard to bend. To ensure easy installation of the cables, consider the optimum placement of the drive. Each terminal allows up to 4 cables with cable lugs or a standard box lug. Ground is connected to a relevant termination point in the drive.

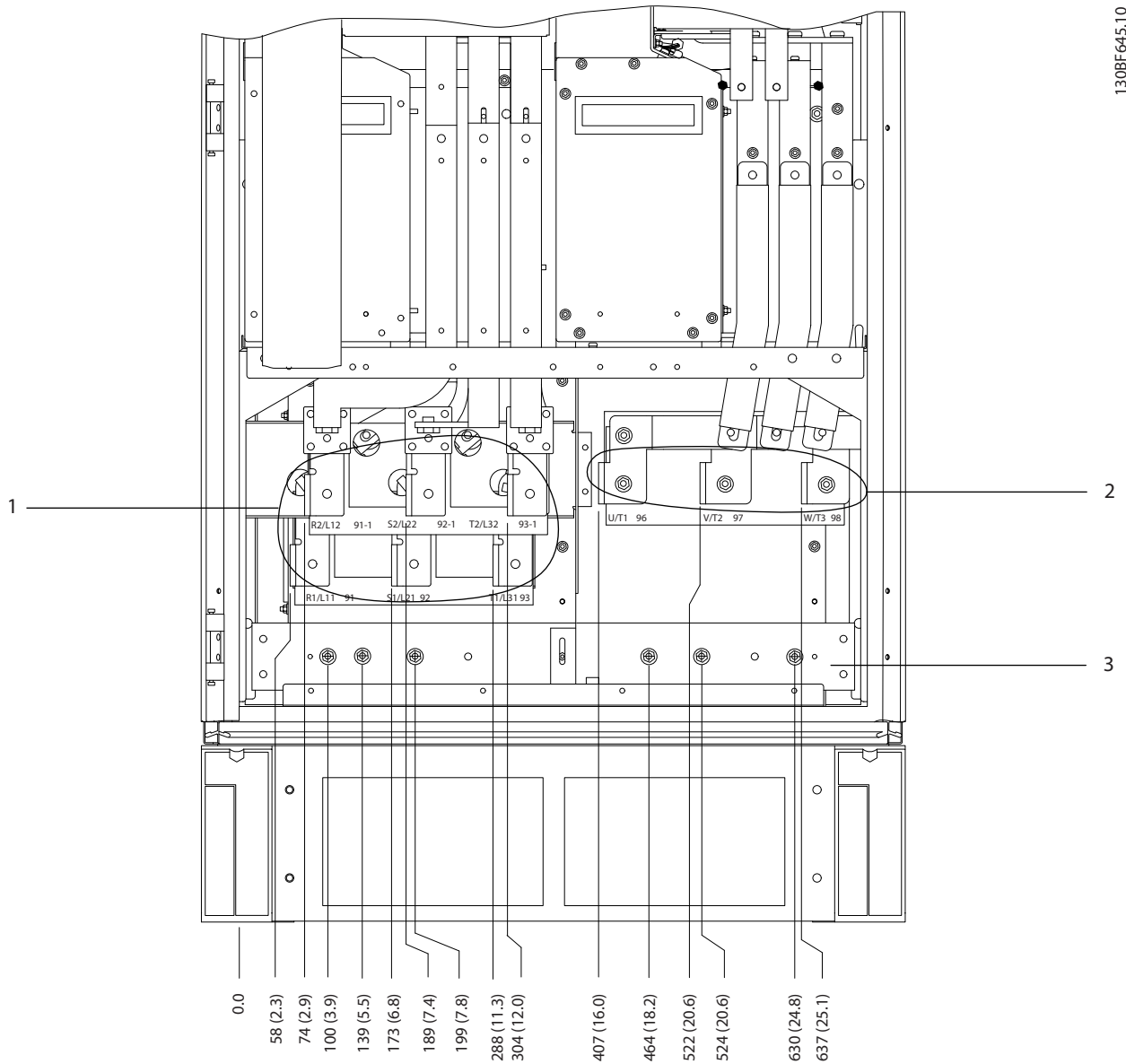

1	Mains terminals	2	Ground bar
---	-----------------	---	------------

Illustration 8.68 Terminal Dimensions for F10-F13 Rectifier Cabinet, Front View

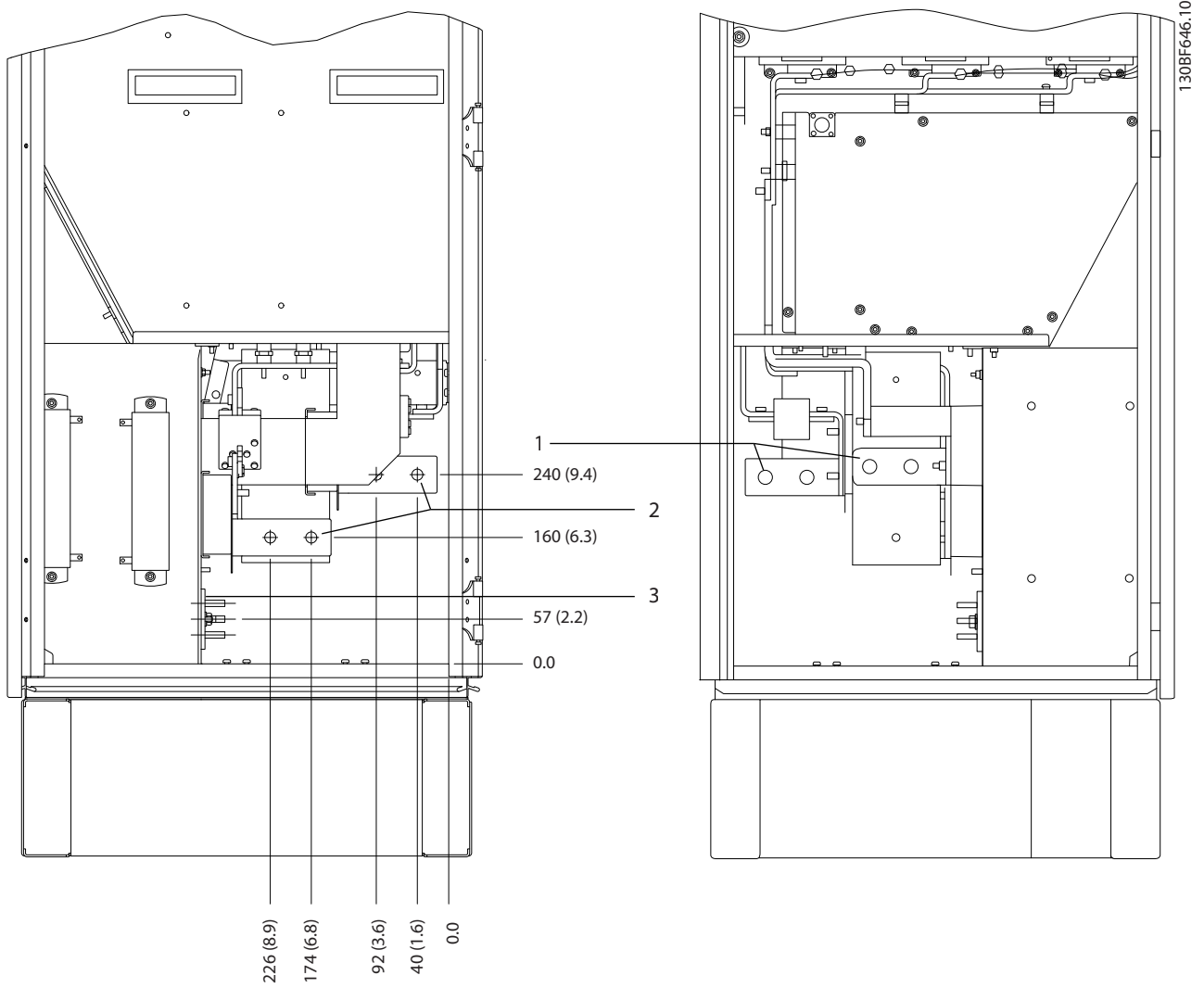

8

Illustration 8.69 Terminal Dimensions for F10–F13 Rectifier Cabinet, Side View

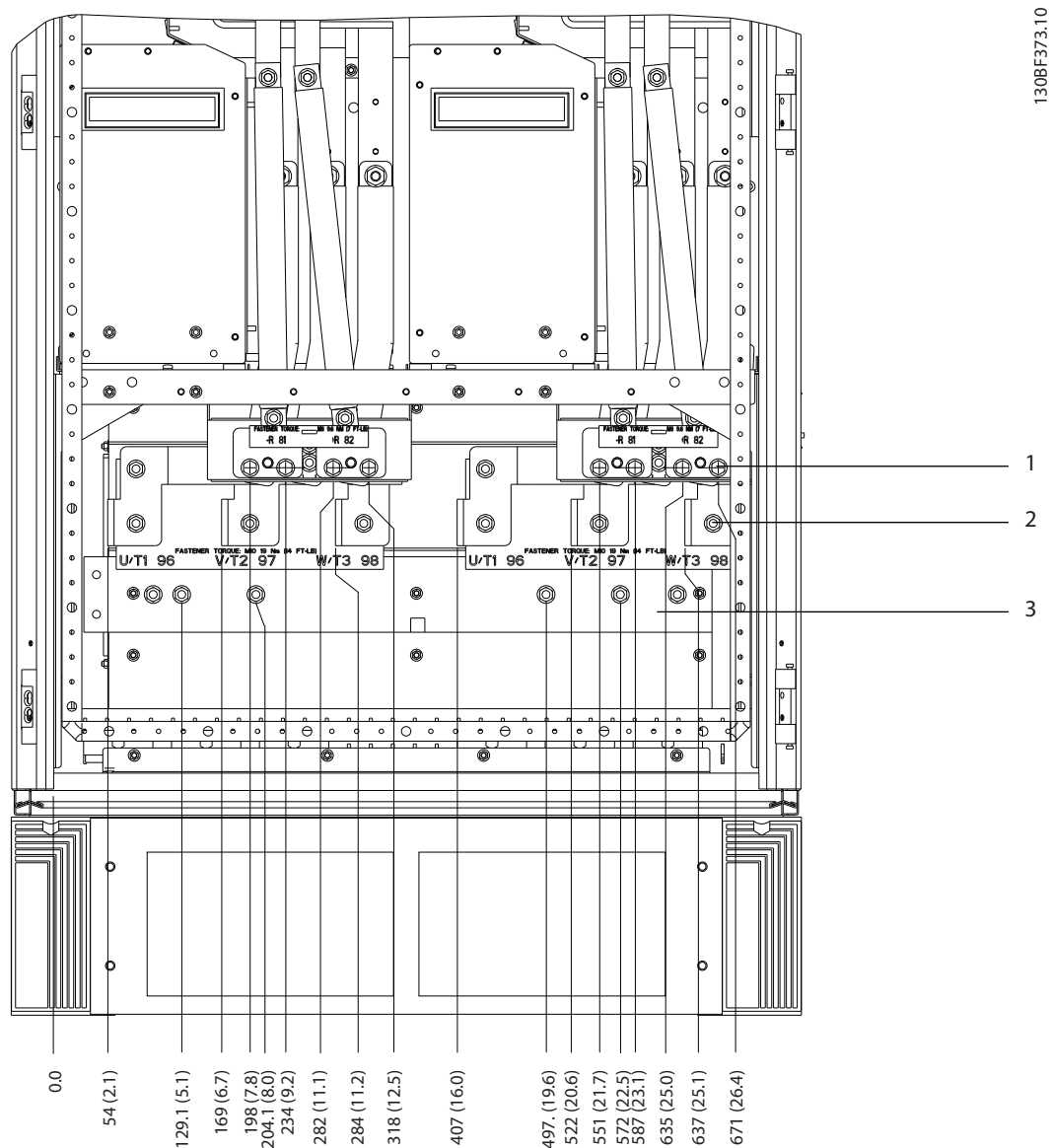

1	Brake terminals	3	Ground bar
2	Motor terminals	-	-

Illustration 8.70 Terminal Dimensions for F10-F11 Inverter Cabinet, Front View



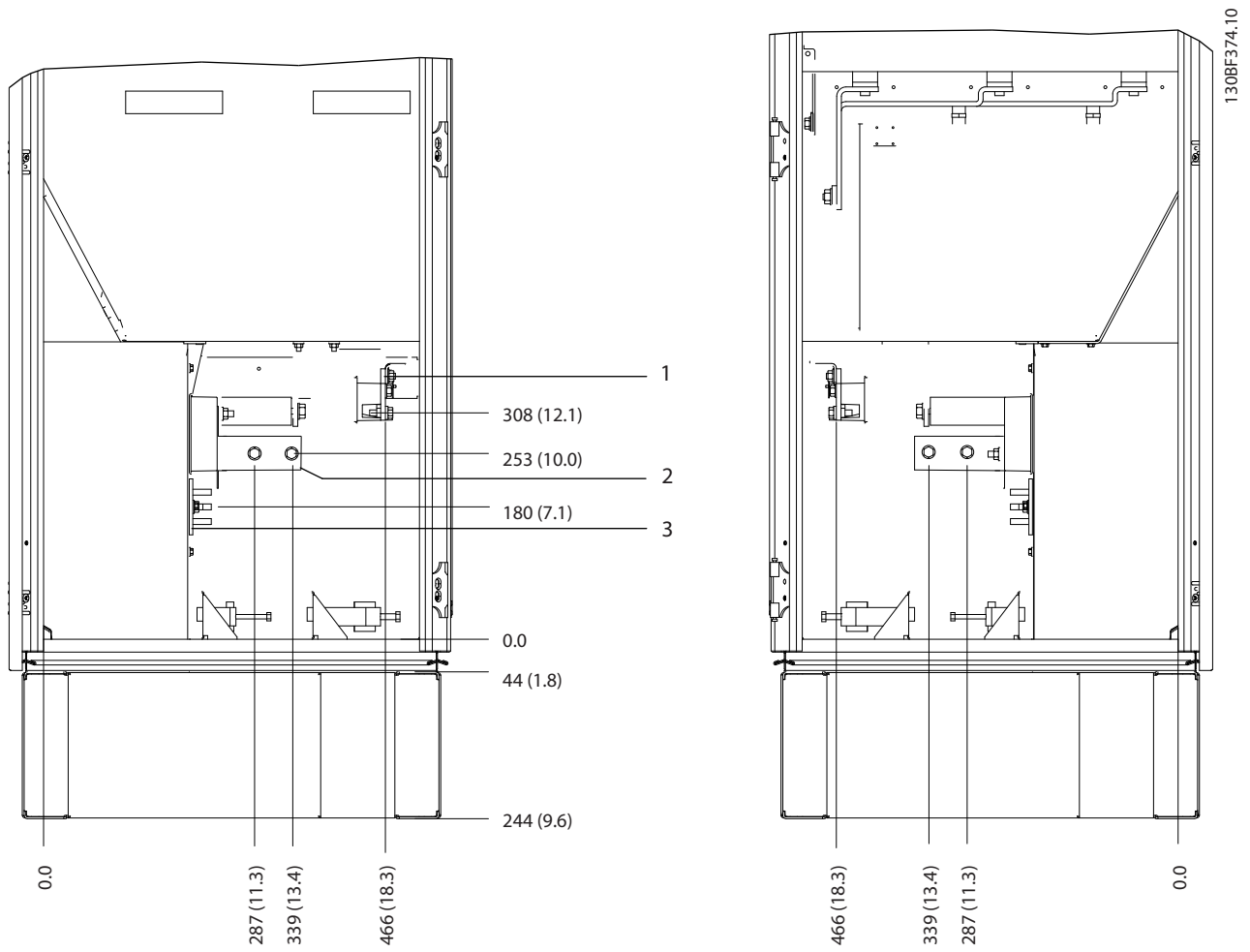

8

1	Brake terminals	3	Ground bar
2	Motor terminals	-	-

Illustration 8.71 Terminal Dimensions for F10-F11 Inverter Cabinet, Side View

8.10 F11 Exterior and Terminal Dimensions

8.10.1 F11 Exterior Dimensions

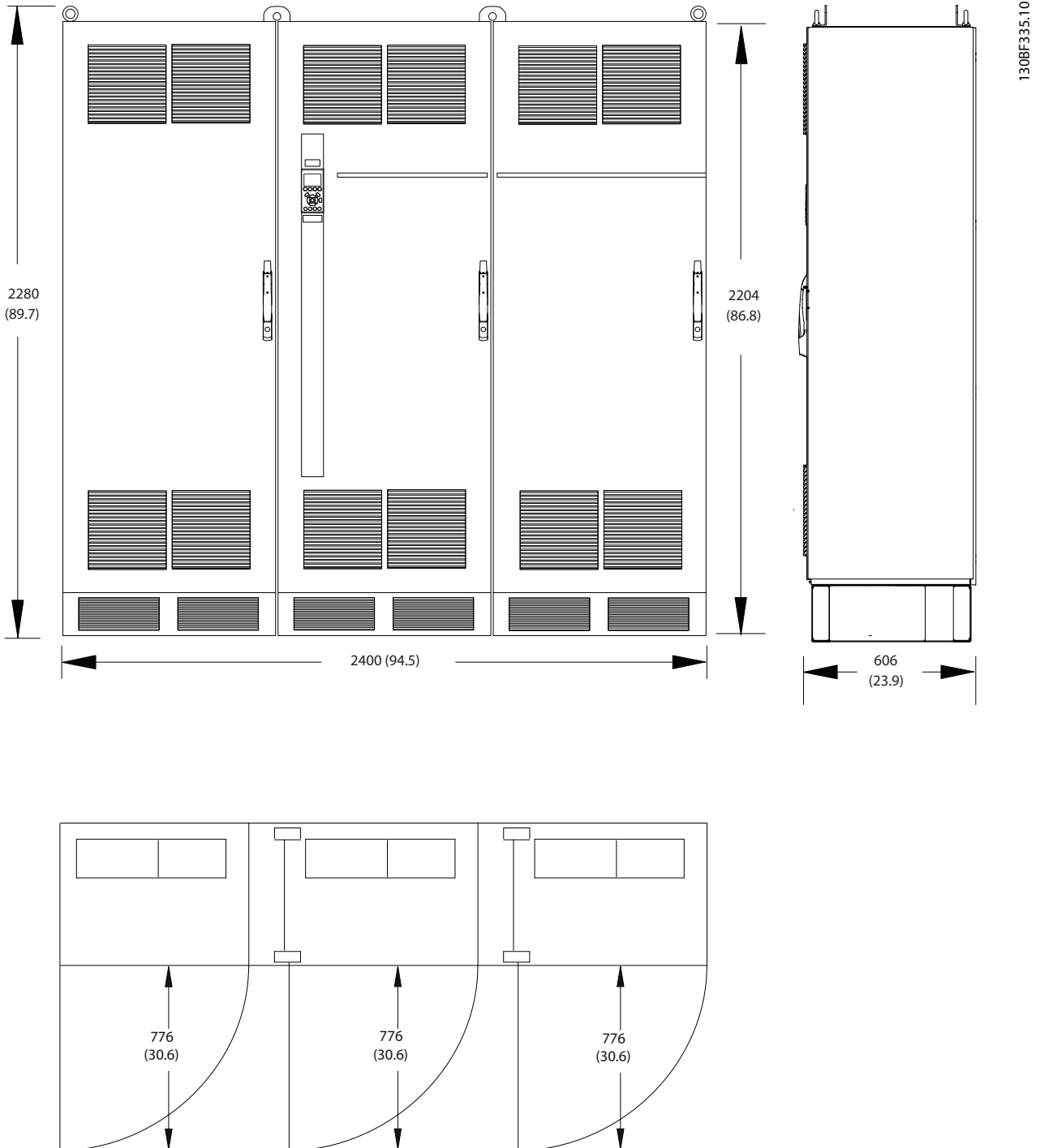
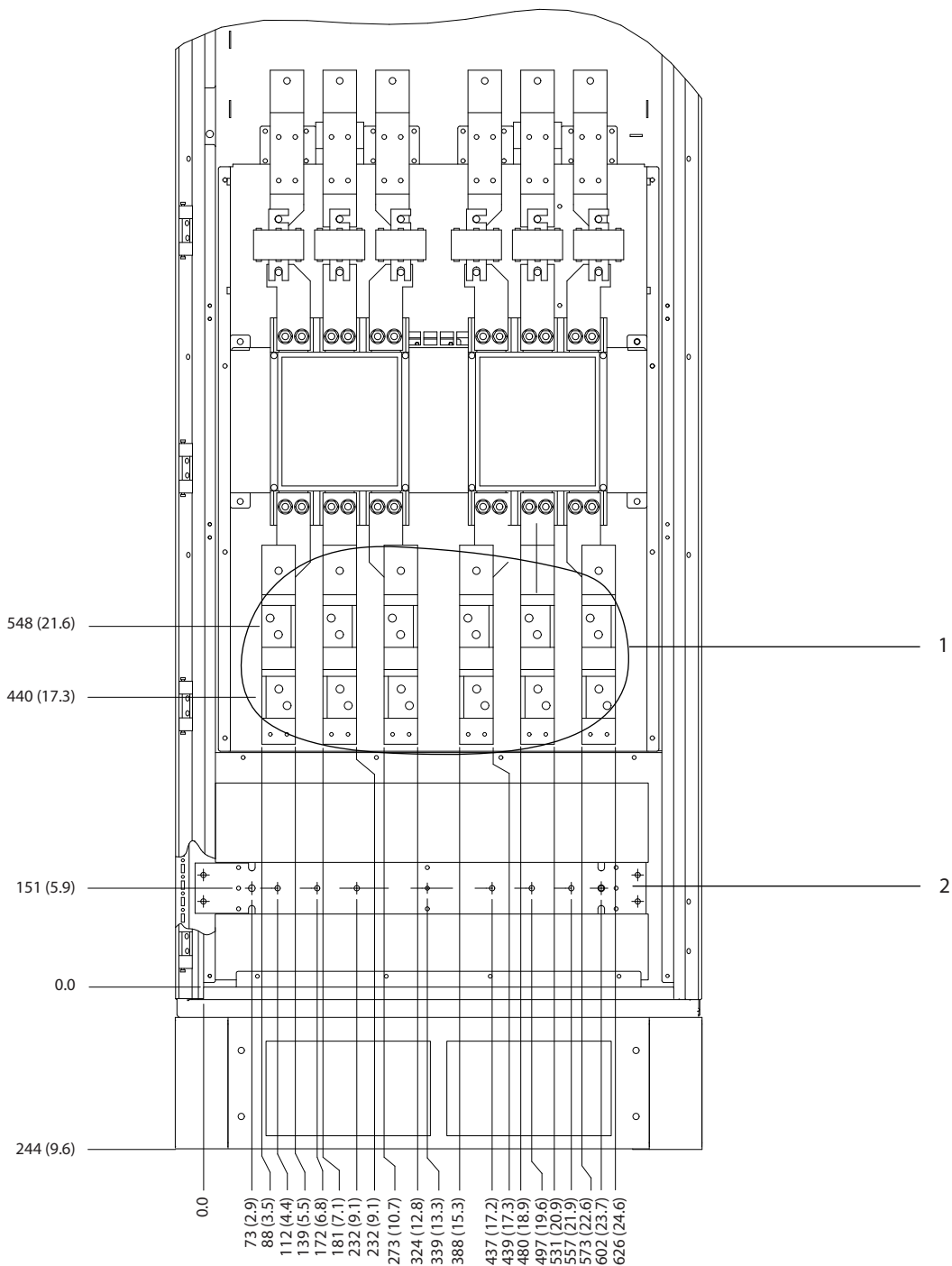

Illustration 8.72 Front, Side, and Door Clearance Dimensions for F11



### 8.10.2 F11 Terminal Dimensions

Power cables are heavy and hard to bend. To ensure easy installation of the cables, consider the optimum placement of the drive. Each terminal allows up to 4 cables with cable lugs or a standard box lug. Ground is connected to a relevant termination point in the drive.



1	Mains terminals	2	Ground bar
---	-----------------	---	------------

Illustration 8.74 Terminal Dimensions for F11/F13 Options Cabinet, Front View

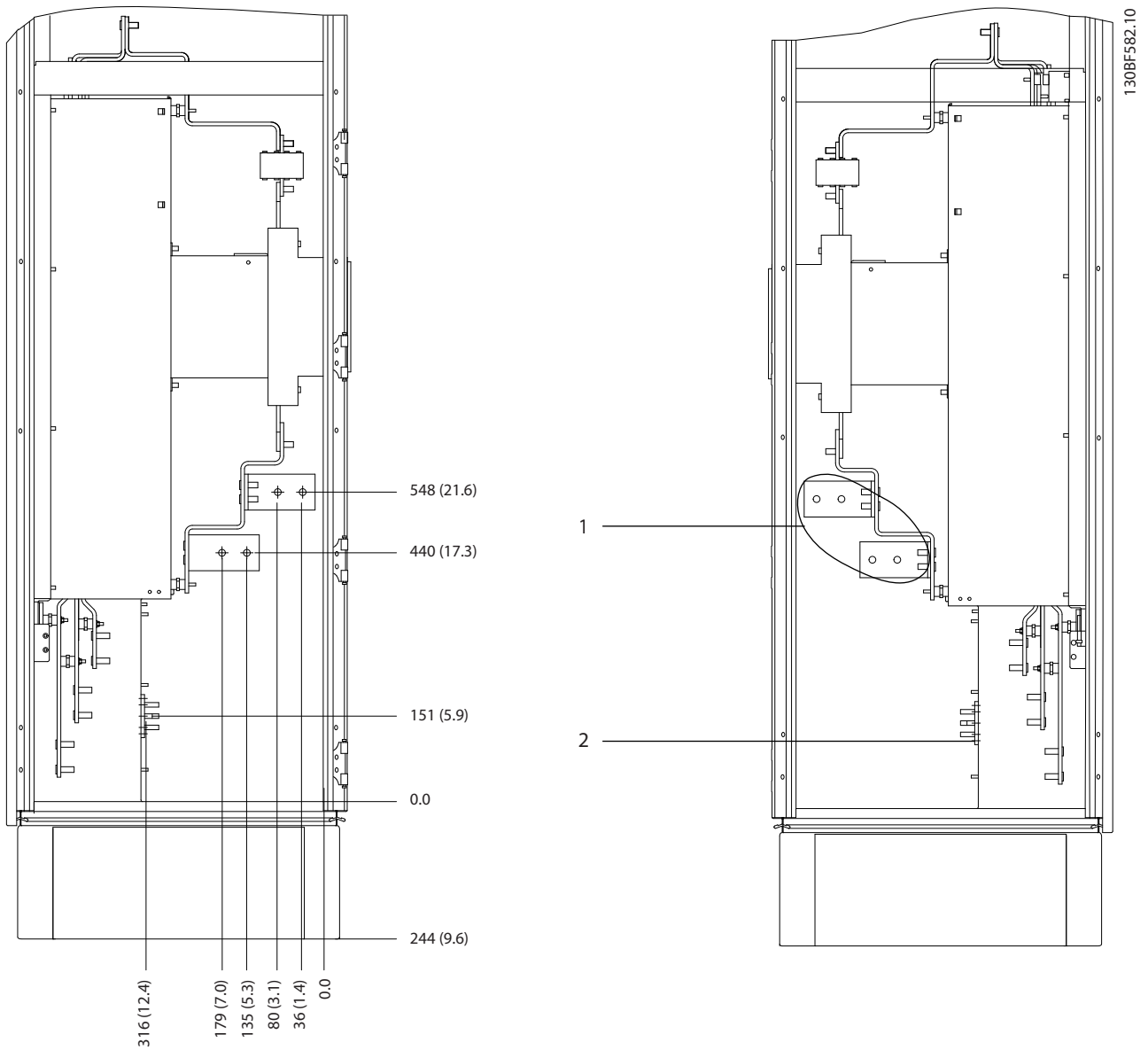

8

1	Mains terminals	2	Ground bar
---	-----------------	---	------------

Illustration 8.75 Terminal Dimensions for F11/F13 Options Cabinet, Side View

8

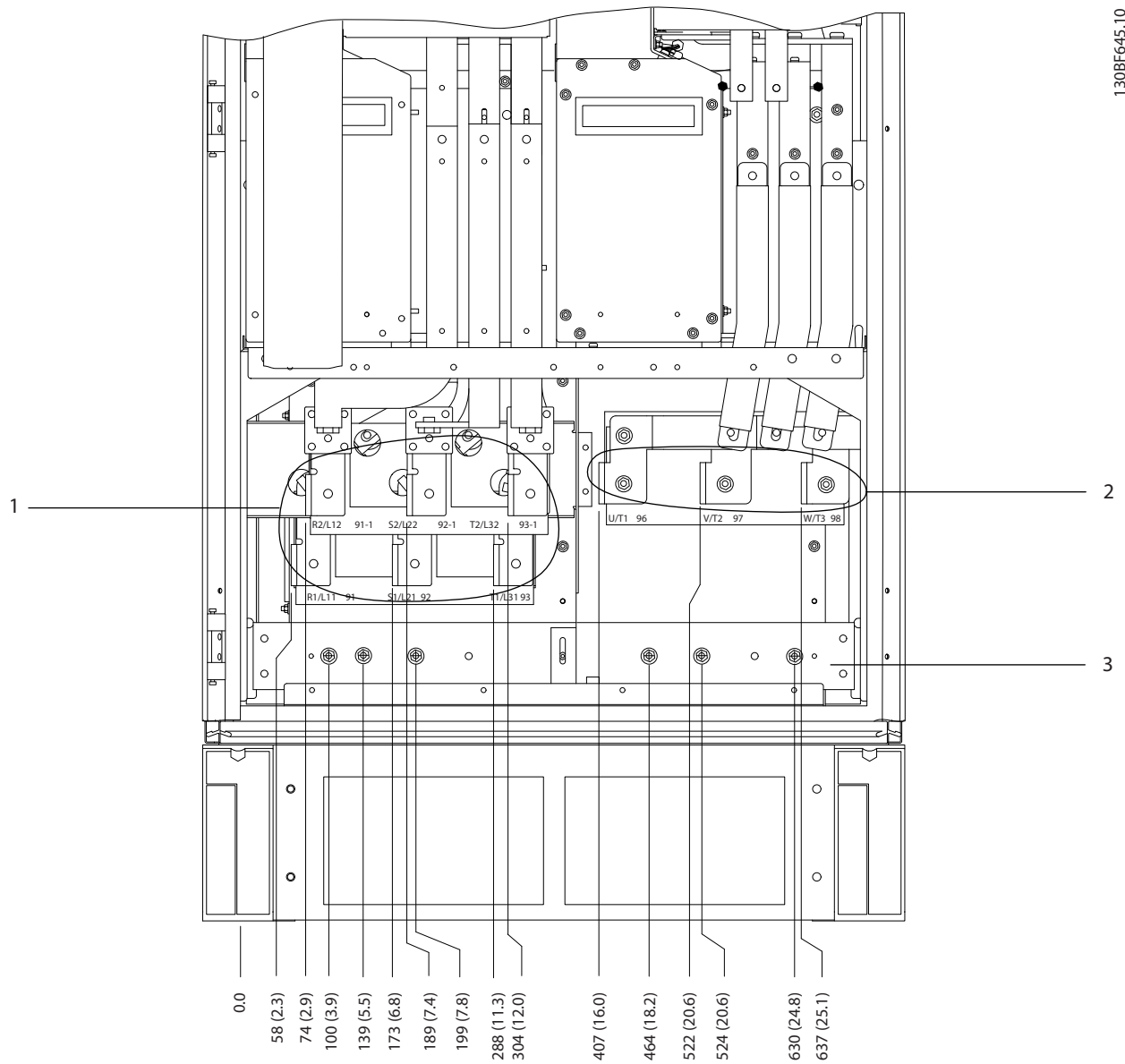

1	Mains terminals	2	Ground bar
---	-----------------	---	------------

Illustration 8.76 Terminal Dimensions for F10–F13 Rectifier Cabinet, Front View

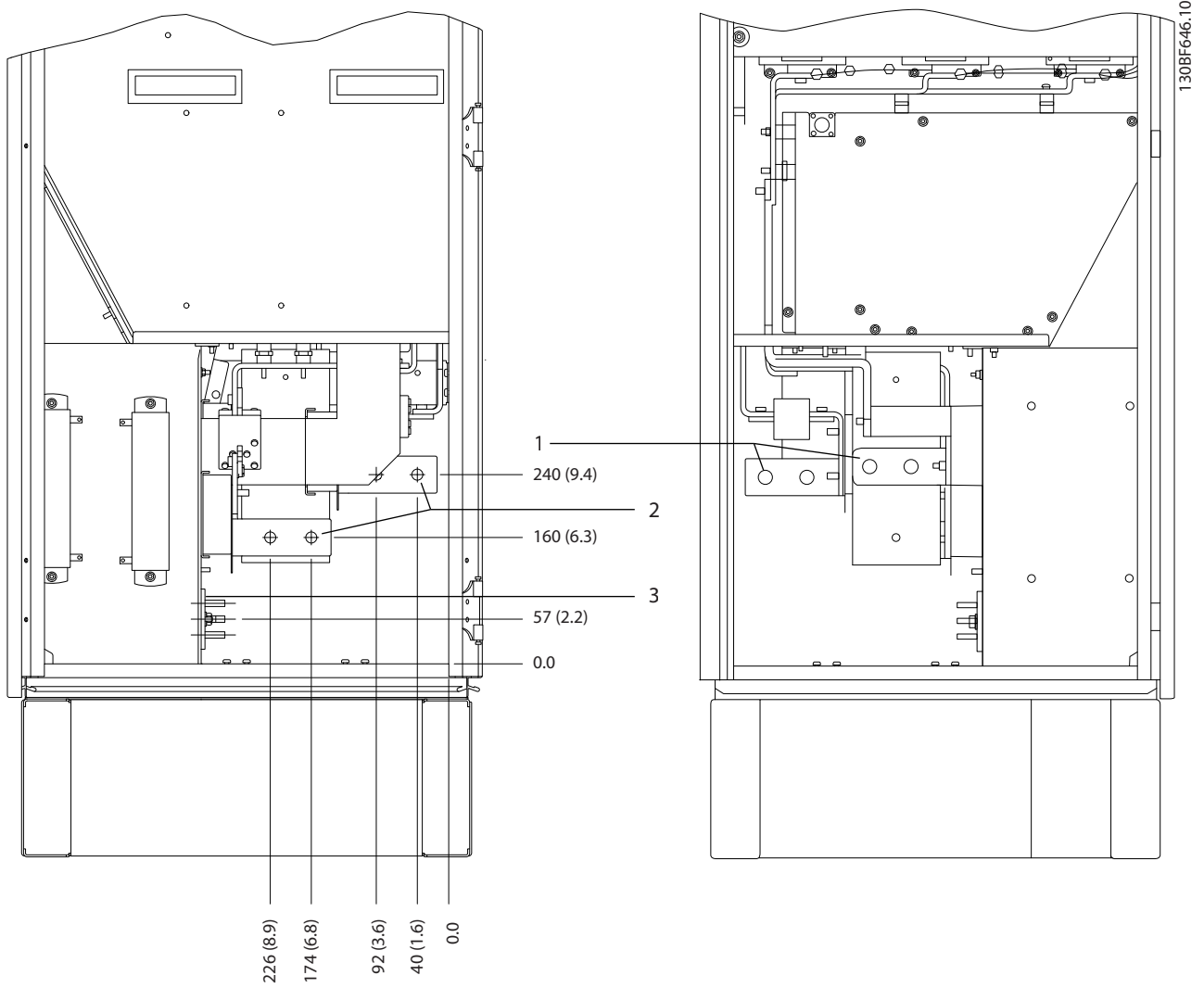

8

1	Mains terminals	2	Ground bar
---	-----------------	---	------------

Illustration 8.77 Terminal Dimensions for F10–F13 Rectifier Cabinet, Side View

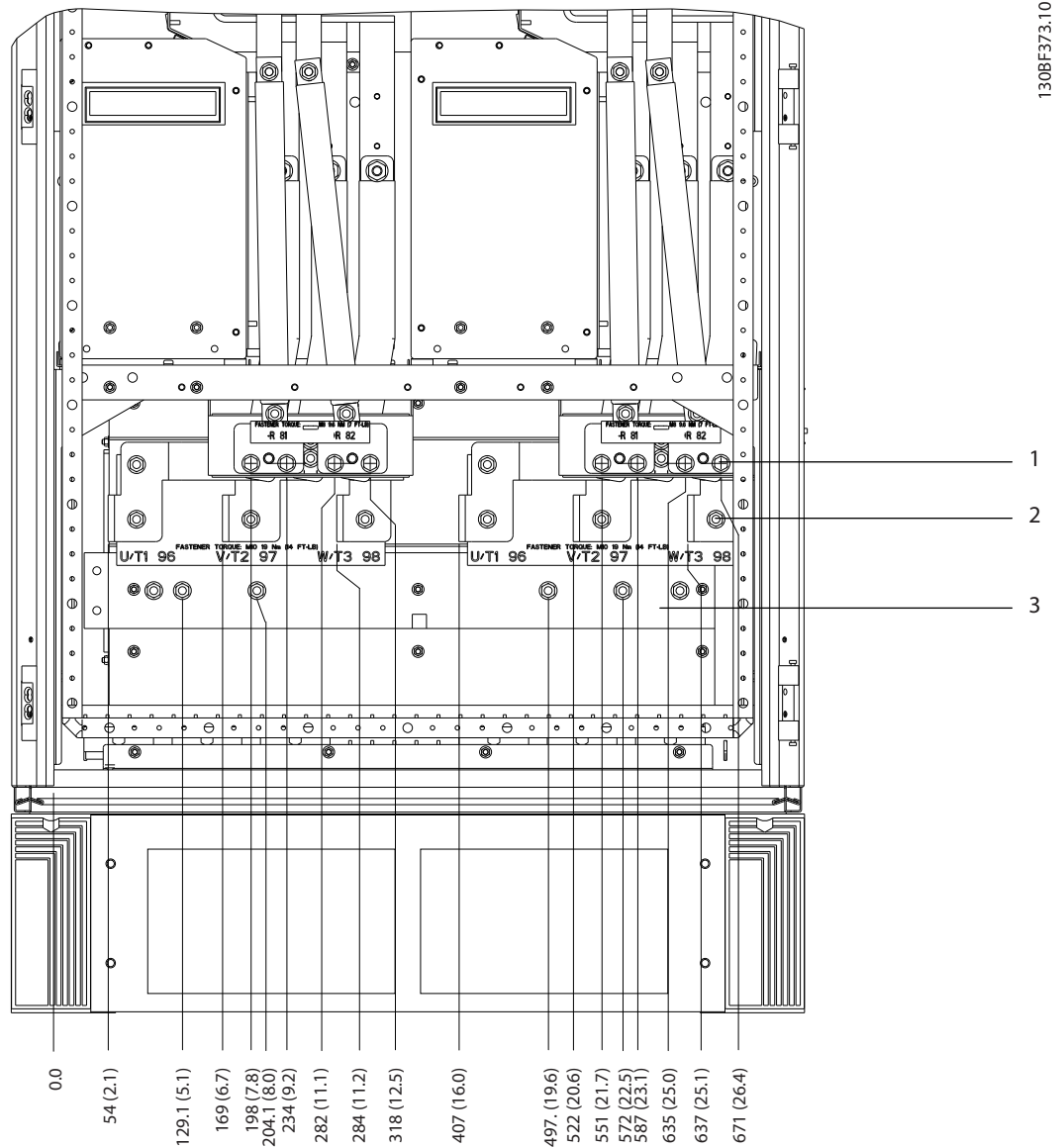

1	Brake terminals	3	Ground bar
2	Motor terminals	-	-

Illustration 8.78 Terminal Dimensions for F10-F11 Inverter Cabinet, Front View



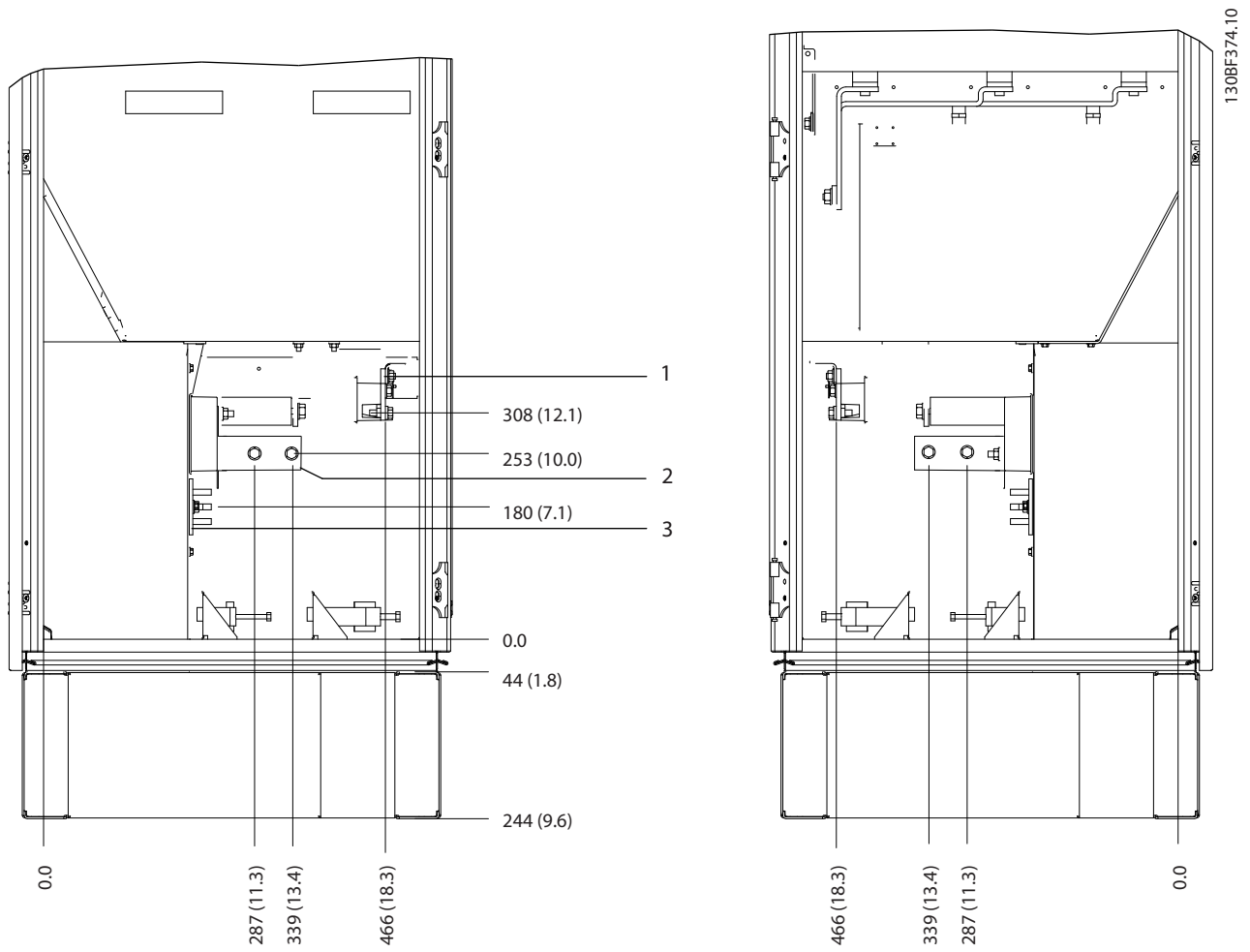

8

1	Brake terminals	3	Ground bar
2	Motor terminals	-	-

Illustration 8.79 Terminal Dimensions for F10-F11 Inverter Cabinet, Side View

8.11 F12 Exterior and Terminal Dimensions

8.11.1 F12 Exterior Dimensions

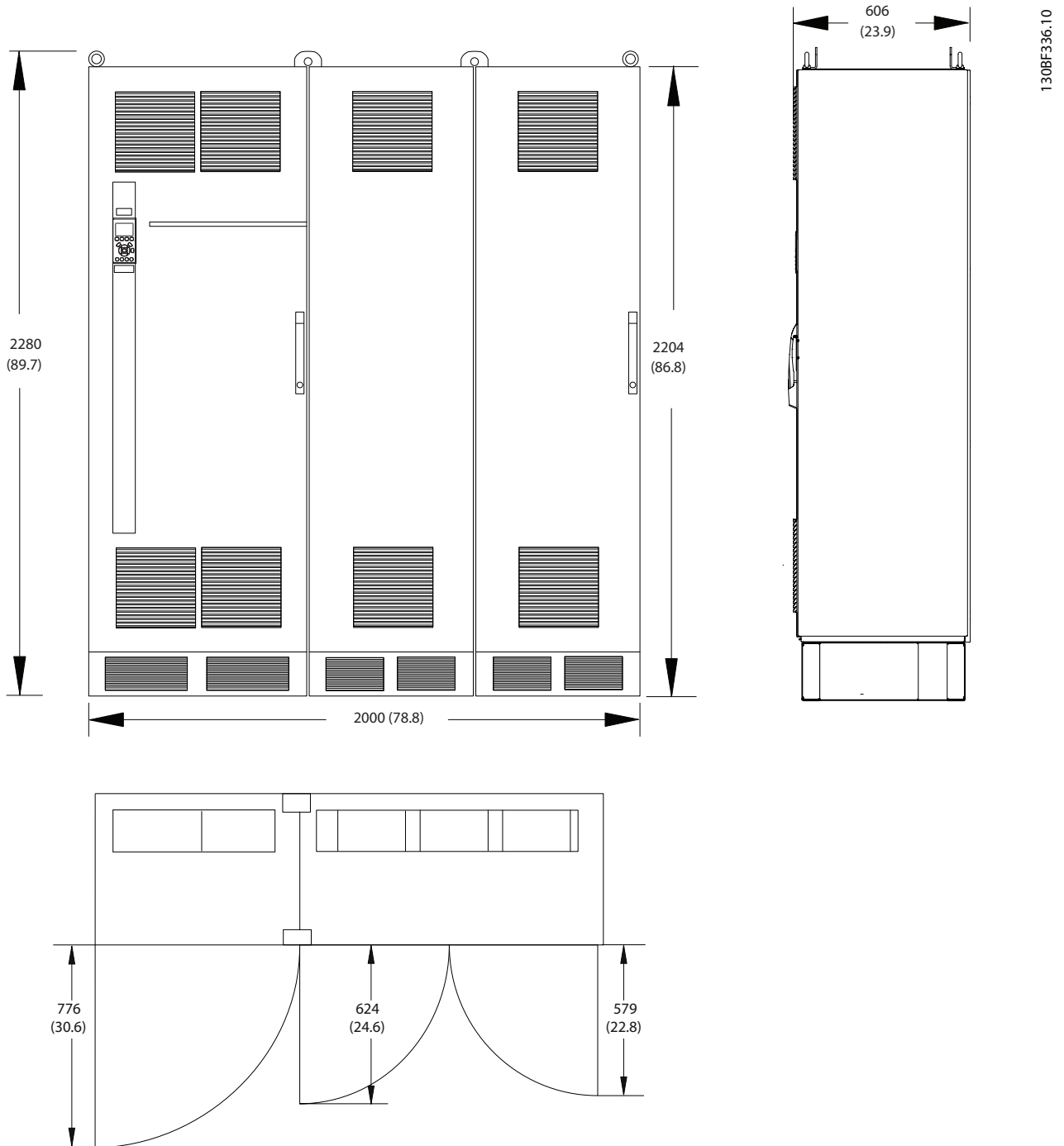

8

Illustration 8.80 Front, Side, and Door Clearance Dimensions for F12

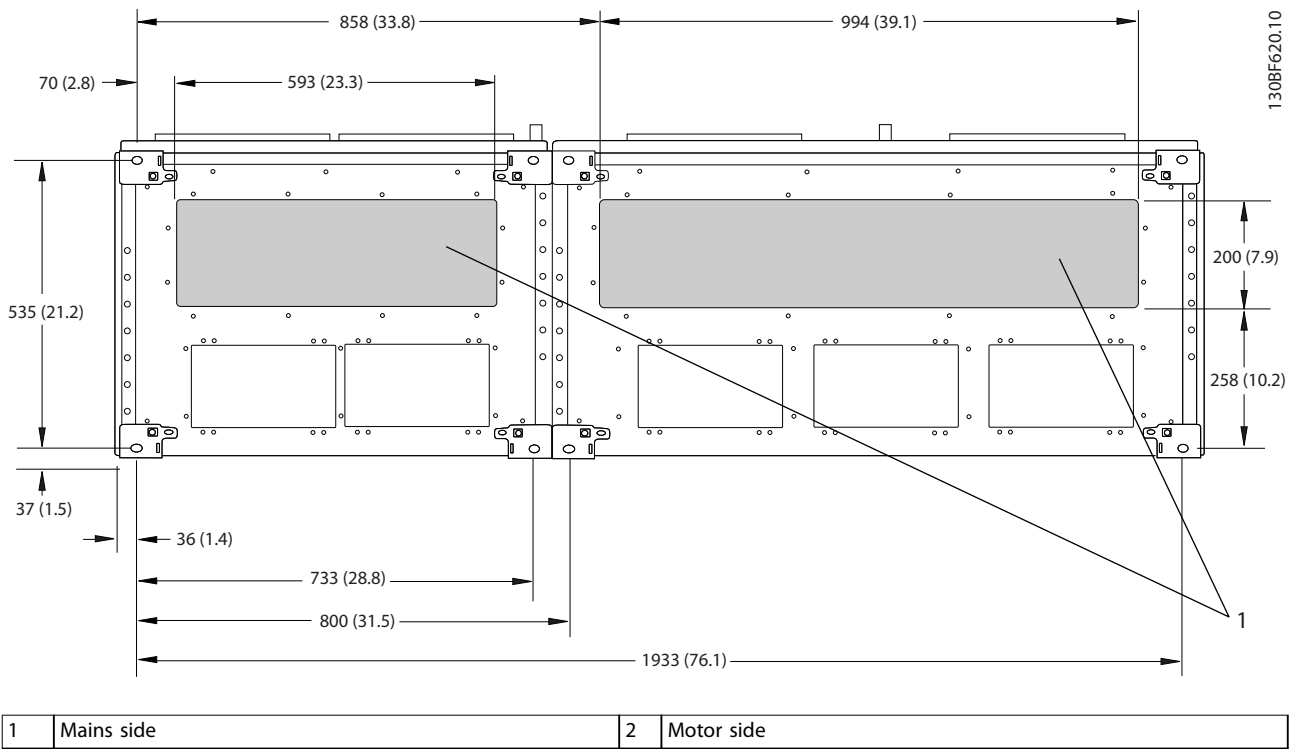
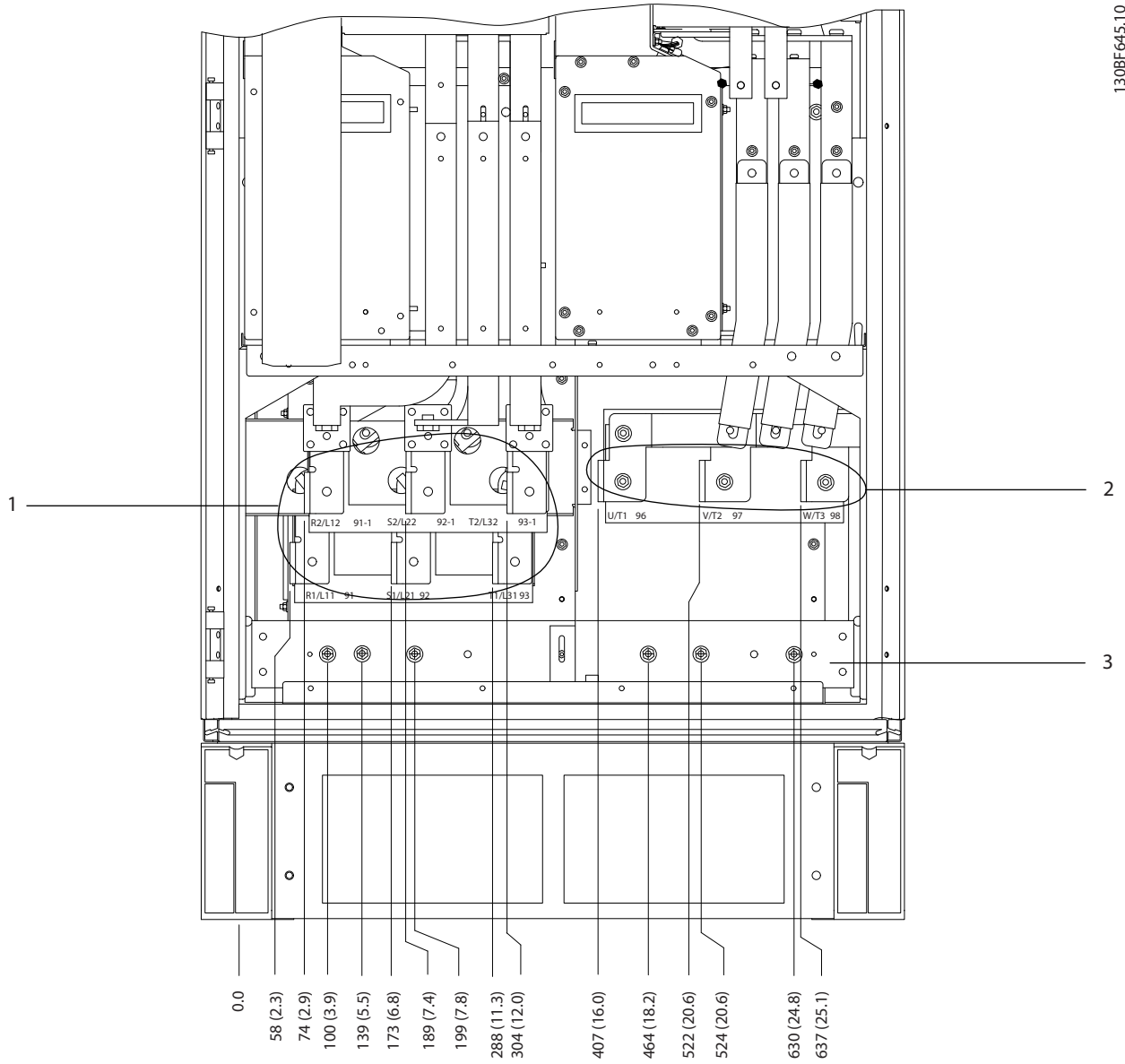

Illustration 8.81 Gland Plate Dimensions for F12

8.11.2 F12 Terminal Dimensions

Power cables are heavy and hard to bend. To ensure easy installation of the cables, consider the optimum placement of the drive. Each terminal allows up to 4 cables with cable lugs or a standard box lug. Ground is connected to a relevant termination point in the drive.



1	Mains terminals	2	Ground bar
---	-----------------	---	------------

Illustration 8.82 Terminal Dimensions for F10–F13 Rectifier Cabinet, Front View

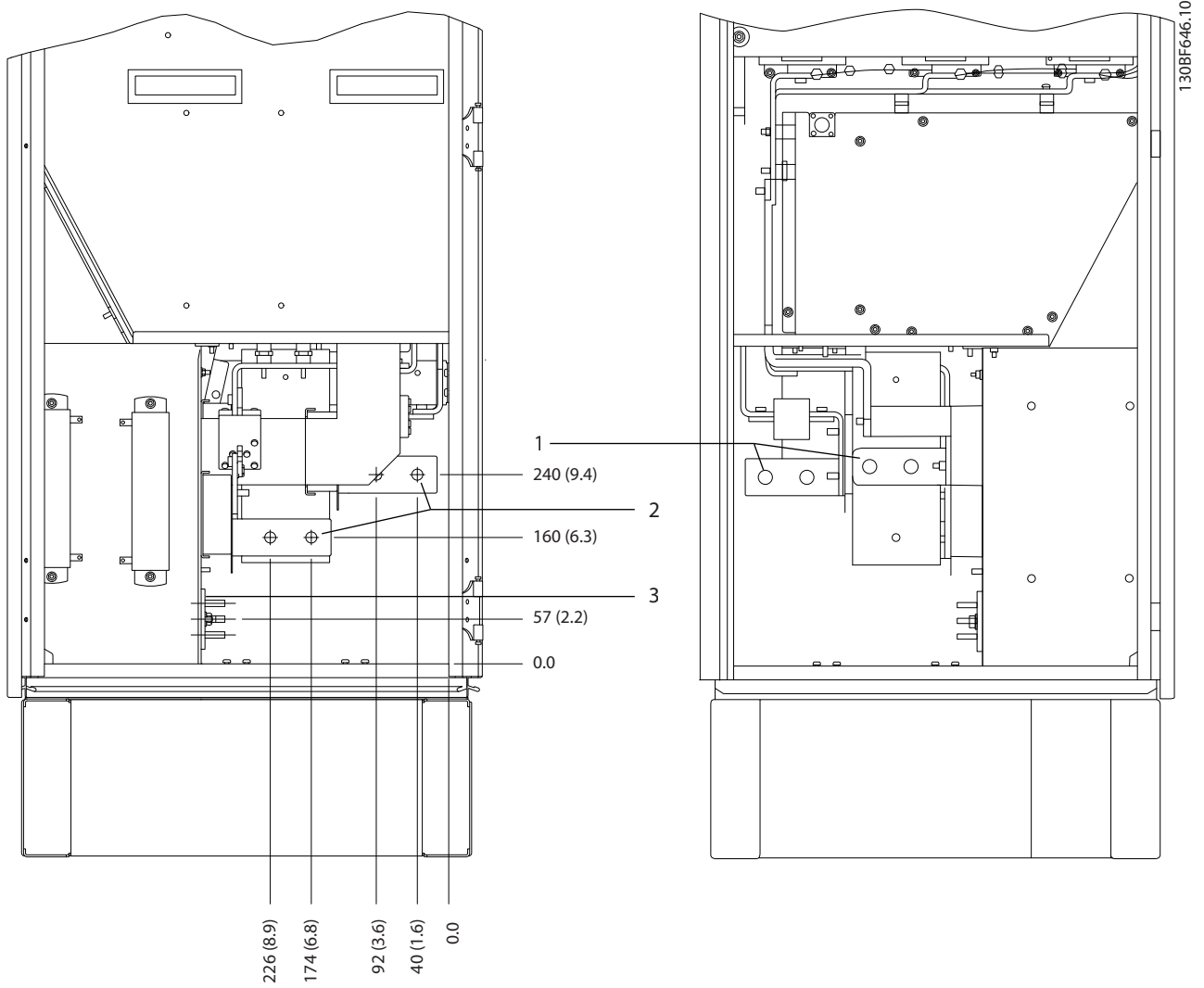
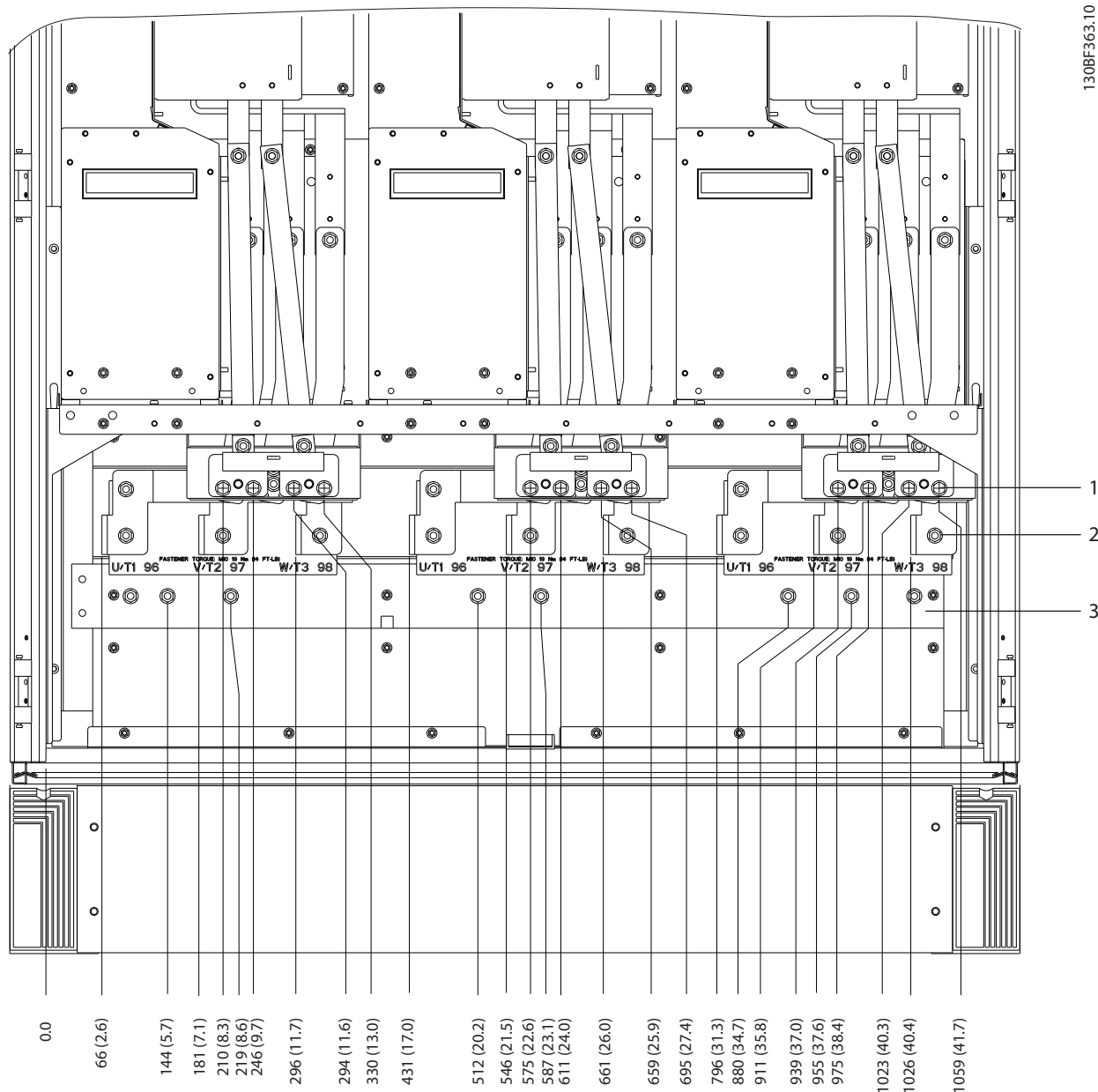

Illustration 8.83 Terminal Dimensions for F10-F13 Rectifier Cabinet, Side View

1308F363.10

8



1	Brake terminals	3	Ground bar
2	Motor terminals	-	-

Illustration 8.84 Terminal Dimensions for F12-F13 Inverter Cabinet, Front View

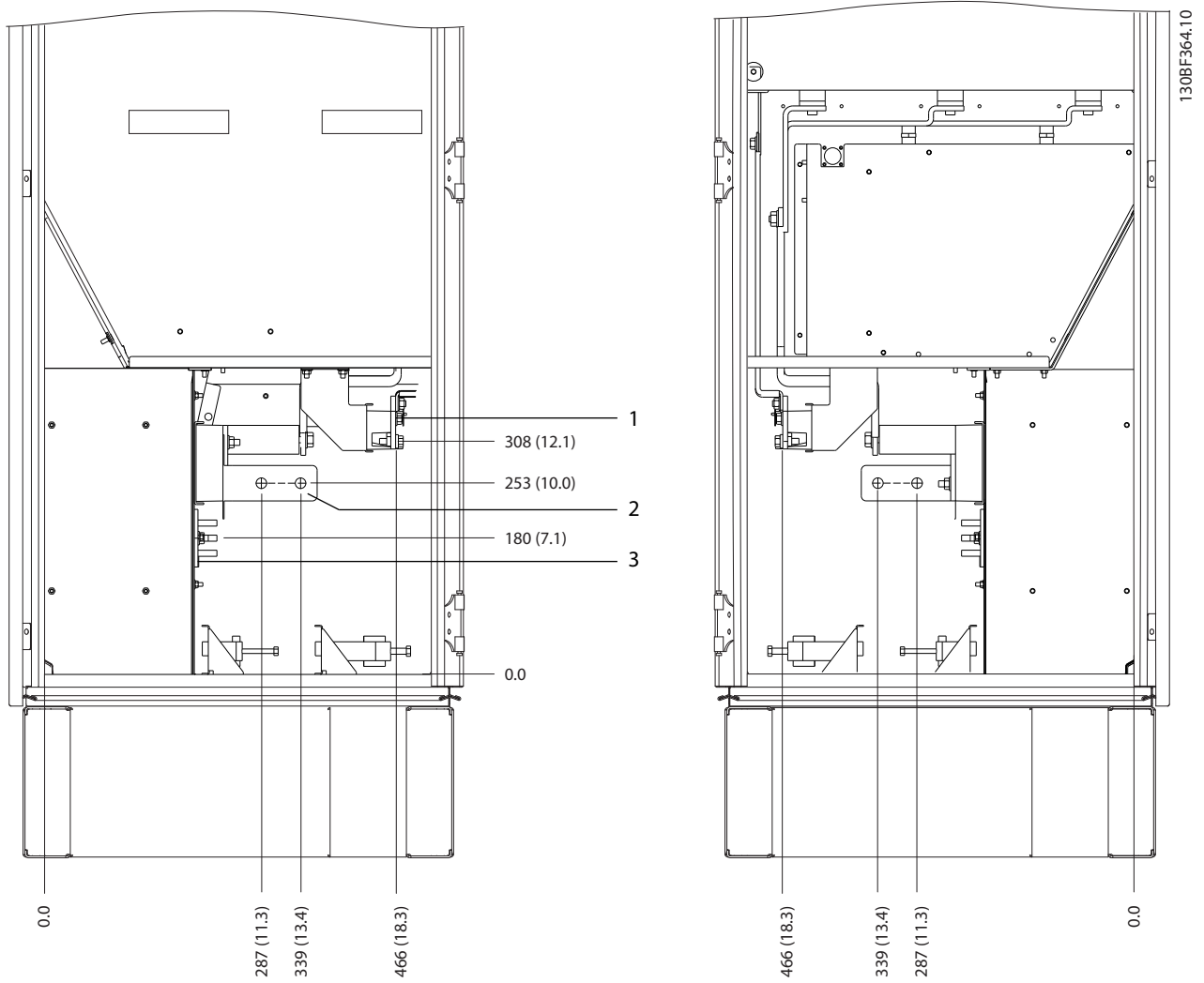

8

1	Brake terminals	3	Ground bar
2	Motor terminals	-	-

Illustration 8.85 Terminal Dimensions for F12-F13 Inverter Cabinet, Side View

8.12 F13 Exterior and Terminal Dimensions

8.12.1 F13 Exterior Dimensions

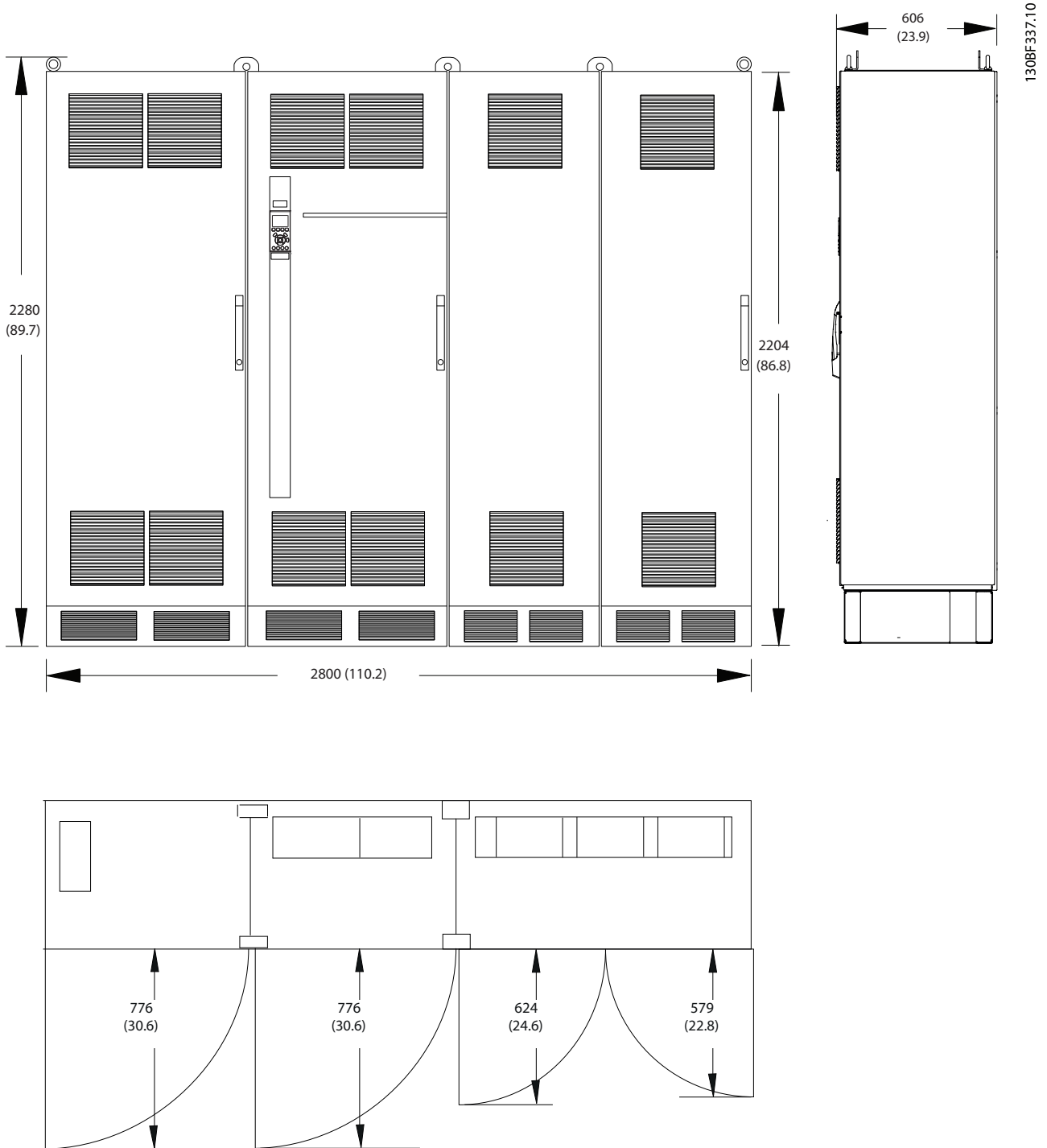
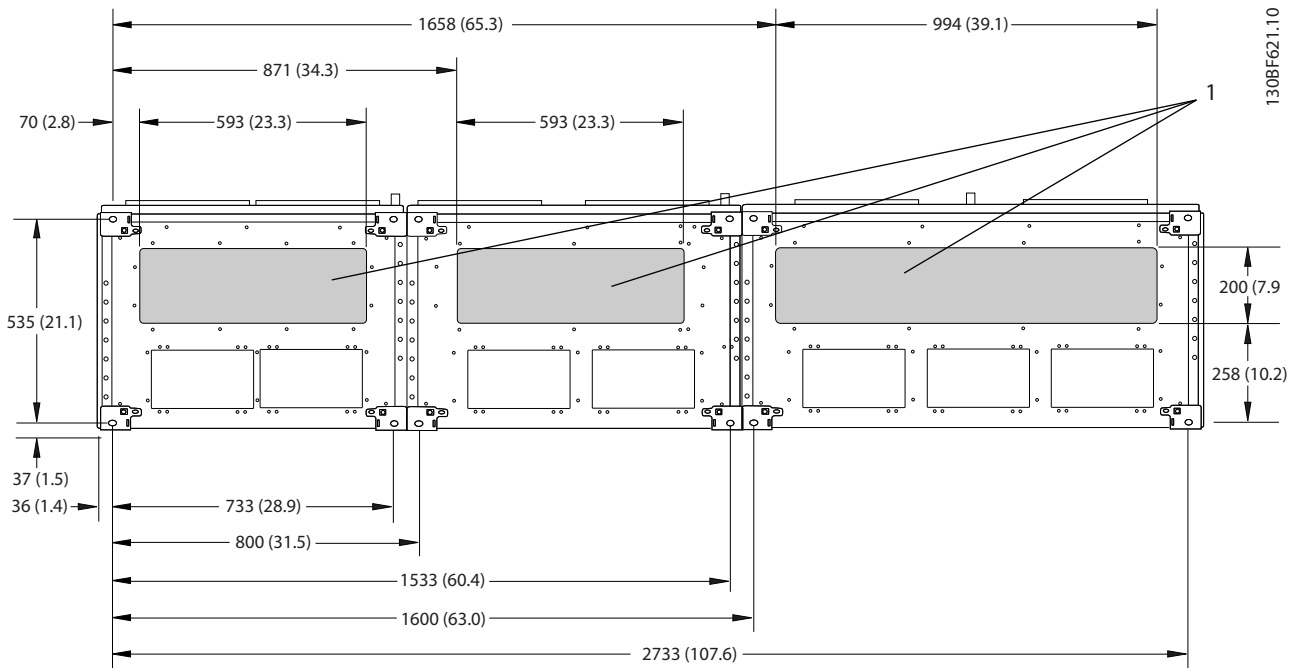

Illustration 8.86 Front, Side, and Door Clearance Dimensions for F13





1	Mains side	2	Motor side
---	------------	---	------------

Illustration 8.87 Gland Plate Dimensions for F13

### 8.12.2 F13 Terminal Dimensions

Power cables are heavy and hard to bend. To ensure easy installation of the cables, consider the optimum placement of the drive. Each terminal allows up to 4 cables with cable lugs or a standard box lug. Ground is connected to a relevant termination point in the drive.

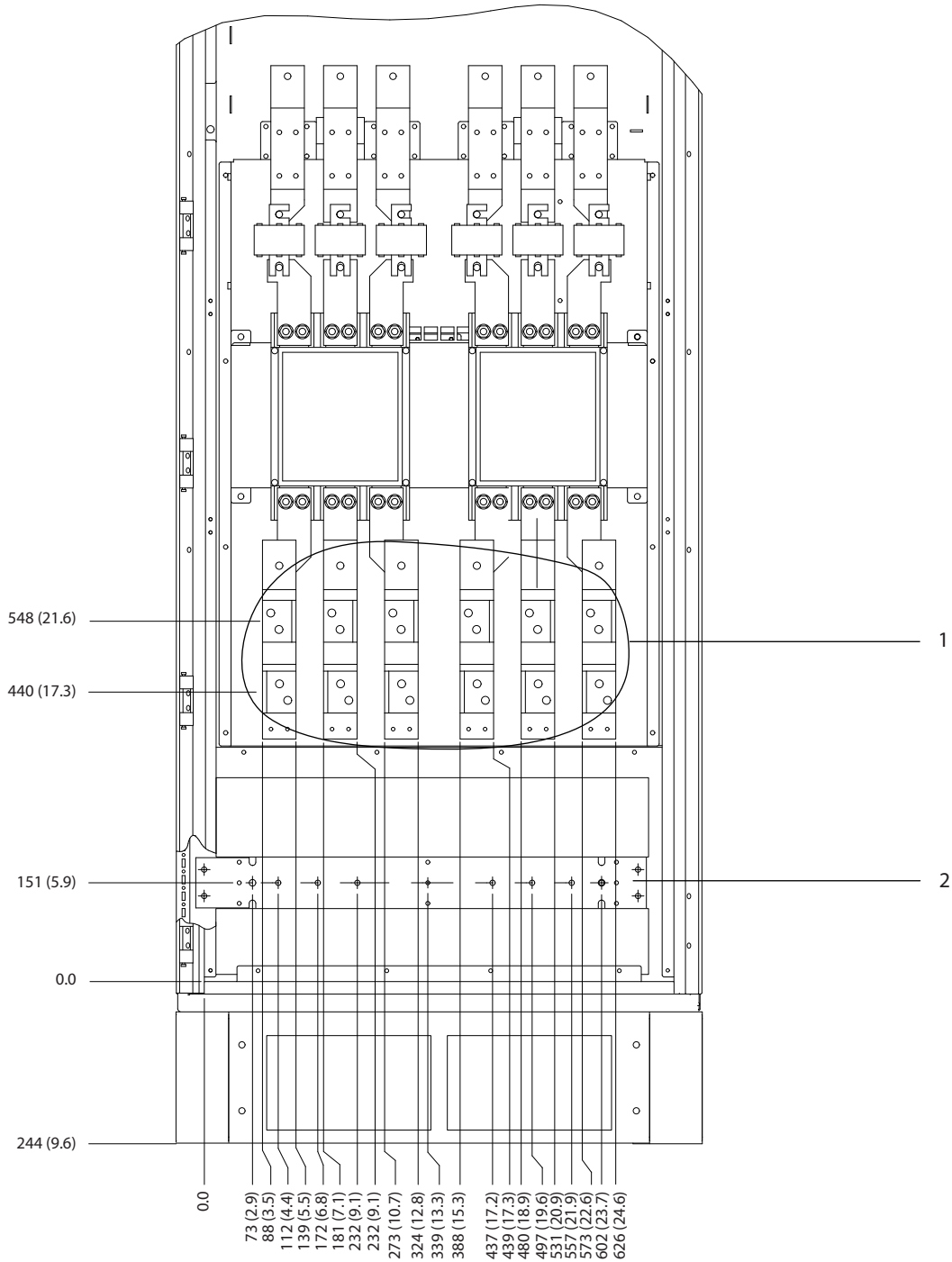

130BF581.10

1	Mains terminals	2	Ground bar
---	-----------------	---	------------

Illustration 8.88 Terminal Dimensions for F11/F13 Options Cabinet, Front View

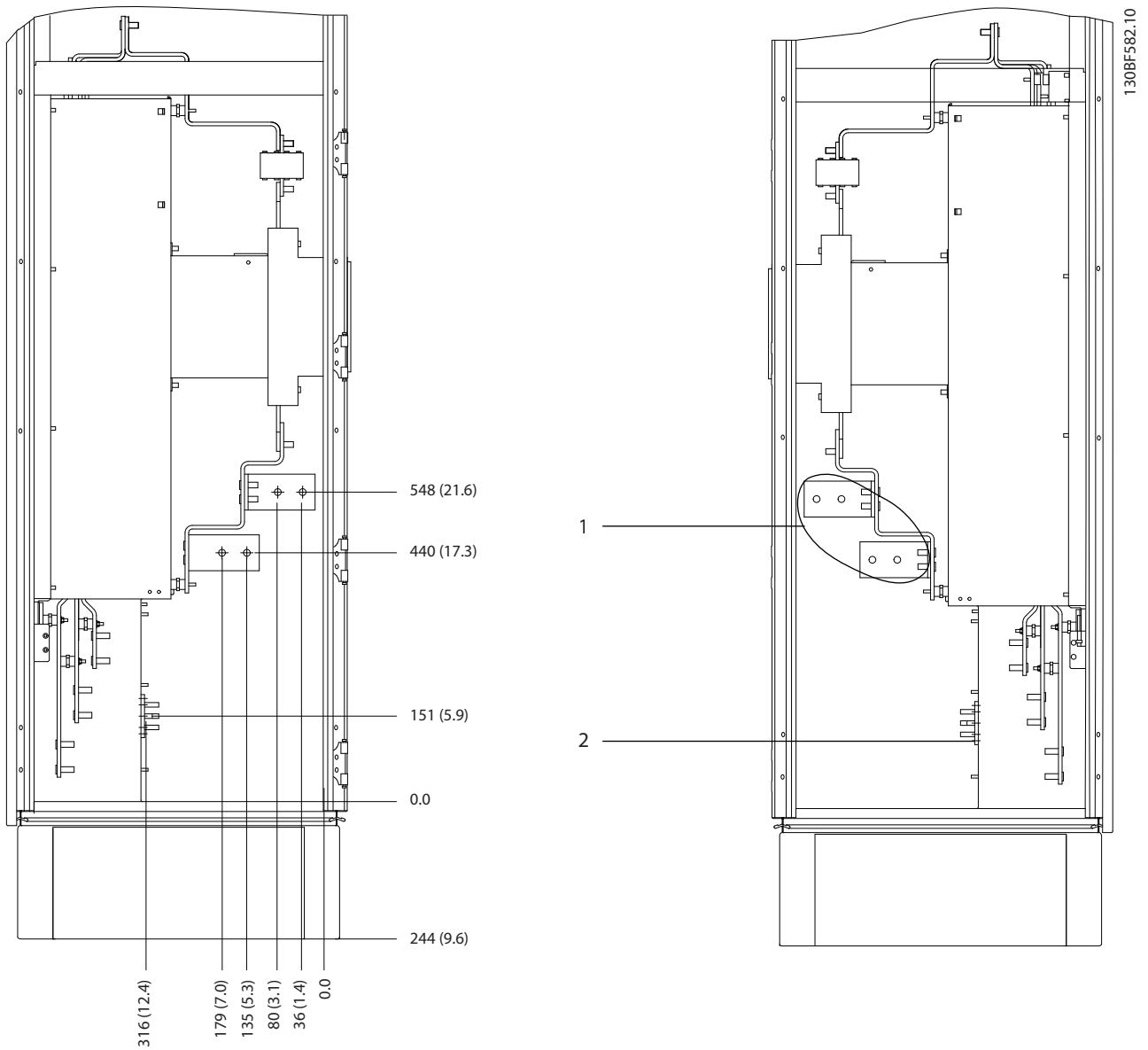

1	Mains terminals	2	Ground bar
---	-----------------	---	------------

Illustration 8.89 Terminal Dimensions for F11/F13 Options Cabinet, Side View

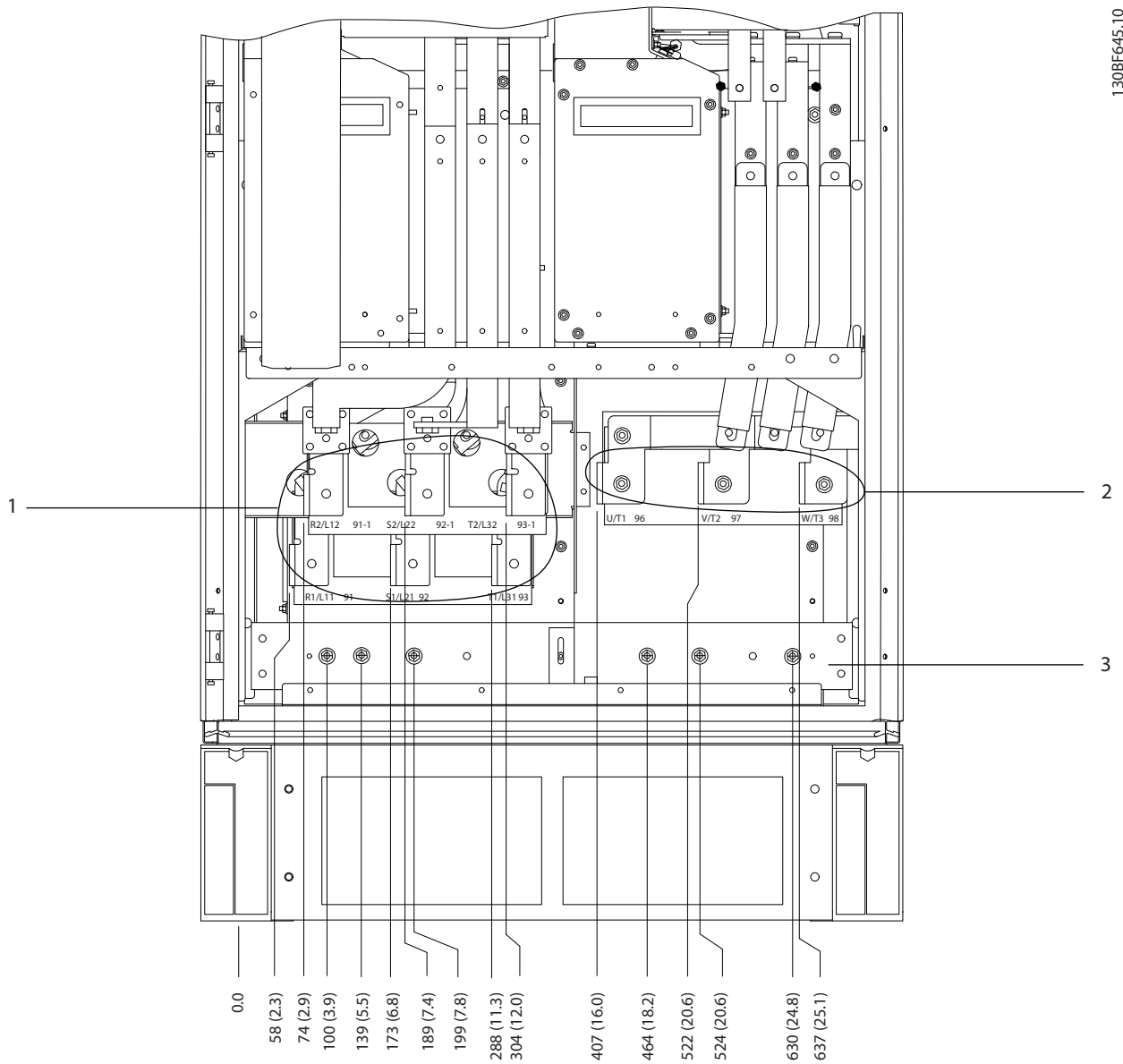

1	Mains terminals	2	Ground bar
---	-----------------	---	------------

Illustration 8.90 Terminal Dimensions for F10–F13 Rectifier Cabinet, Front View

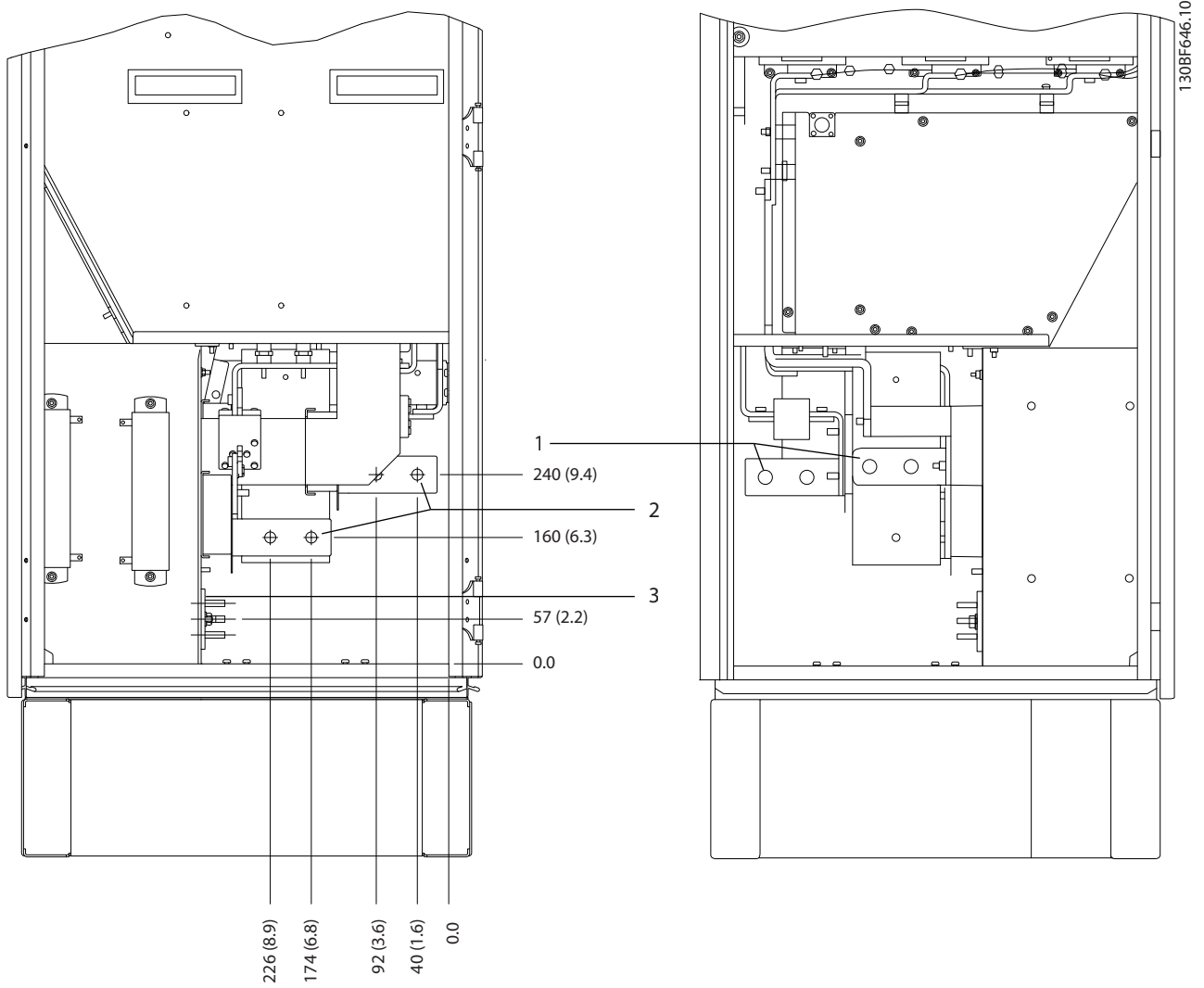

8

1	Mains terminals	2	Ground bar
---	-----------------	---	------------

Illustration 8.91 Terminal Dimensions for F10–F13 Rectifier Cabinet, Side View

1308F363.10

8

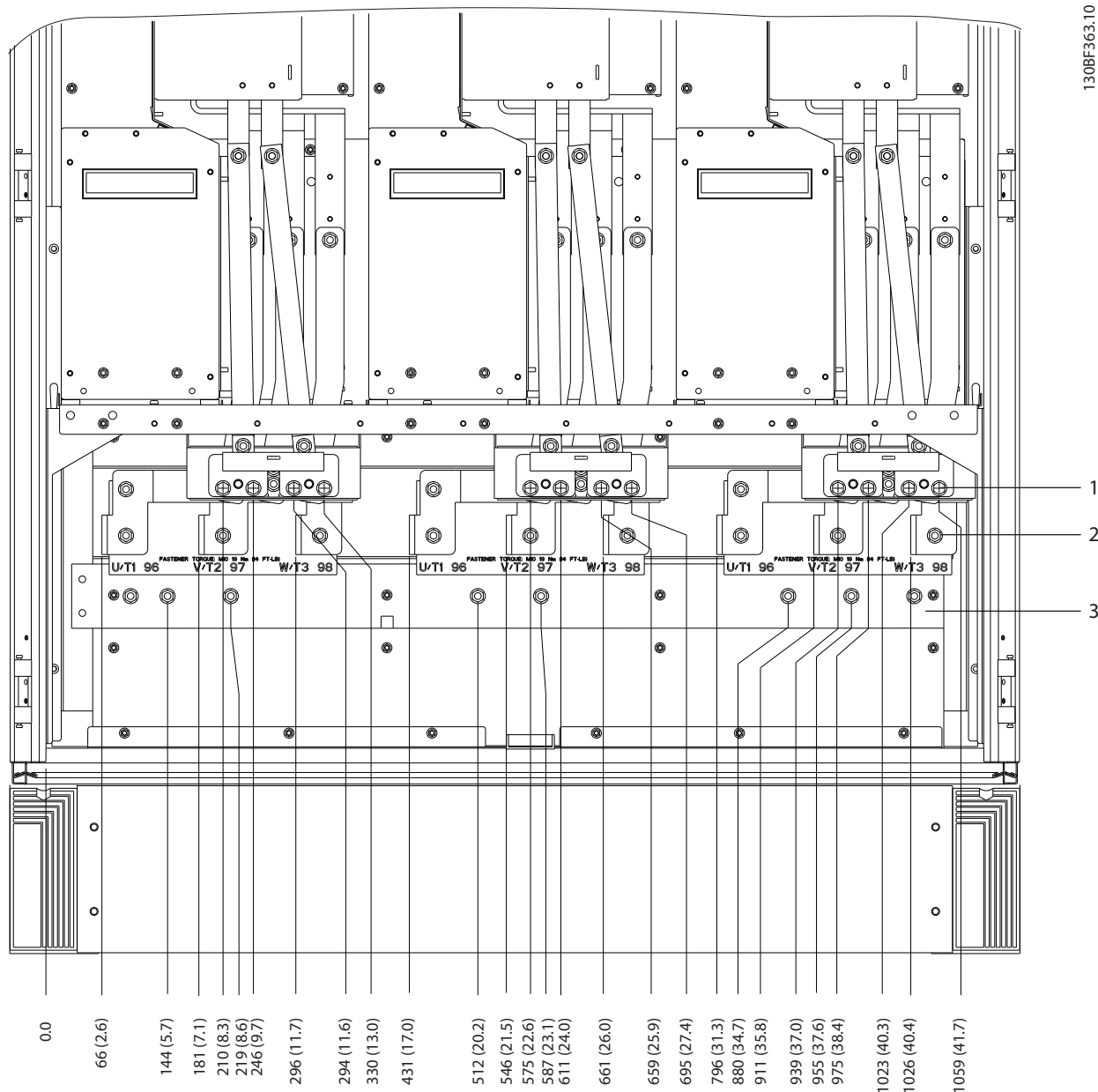

1	Brake terminals	3	Ground bar
2	Motor terminals	-	-

Illustration 8.92 Terminal Dimensions for F12-F13 Inverter Cabinet, Front View

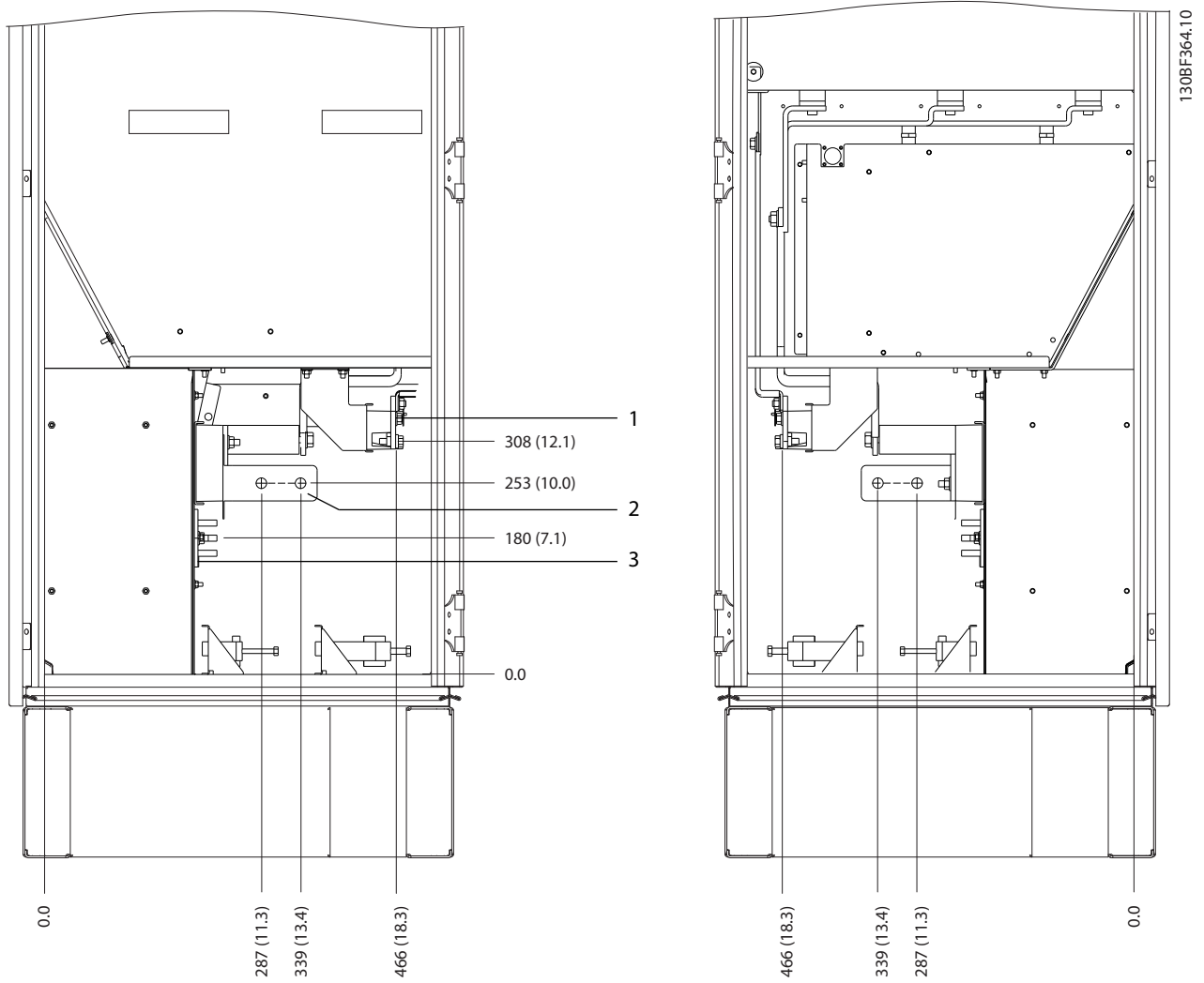

8

1	Brake terminals	3	Ground bar
2	Motor terminals	-	-

Illustration 8.93 Terminal Dimensions for F12-F13 Inverter Cabinet, Side View

## 9 Mechanical Installation Considerations

### 9.1 Storage

Store the drive in a dry location. Keep the equipment sealed in its packaging until installation. Refer to *chapter 7.5.1 Ambient Conditions* for recommended ambient temperature.

Periodic forming (capacitor charging) is not necessary during storage unless storage exceeds 12 months.

### 9.2 Lifting the Unit

Always lift the drive using the dedicated lifting eyes. To avoid bending the lifting holes, use a bar.

#### **⚠ WARNING**

#### **RISK OF INJURY OR DEATH**

Follow local safety regulations for lifting heavy weights. Failure to follow recommendations and local safety regulations can result in death or serious injury.

- Ensure that the lifting equipment is in proper working condition.
- See *chapter 4 Product Overview* for the weight of the different enclosure sizes.
- Maximum diameter for bar: 20 mm (0.8 in).
- The angle from the top of the drive to the lifting cable: 60° or greater.

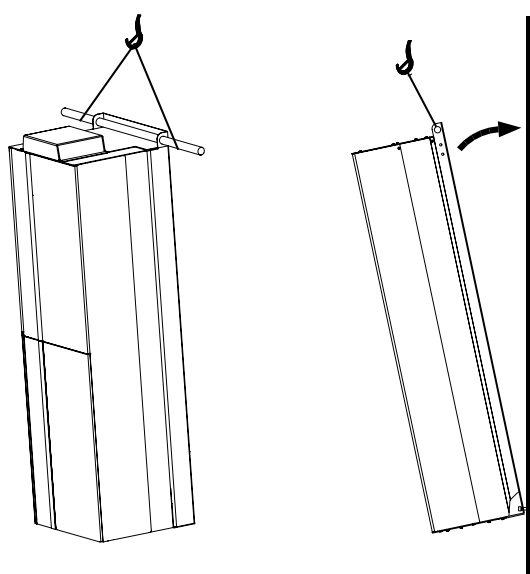

Illustration 9.1 Recommended Lifting Method for E1-E2 Enclosures

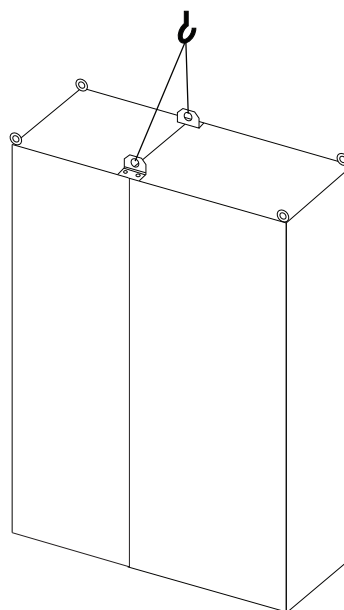

Illustration 9.2 Recommended Lifting Method for F1/F2/F9/F10 Enclosures

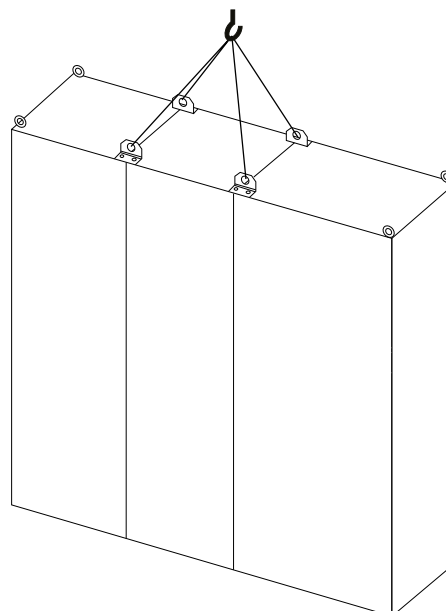

Illustration 9.3 Recommended Lifting Method for F3/F4/F11/F12/F13 Enclosures



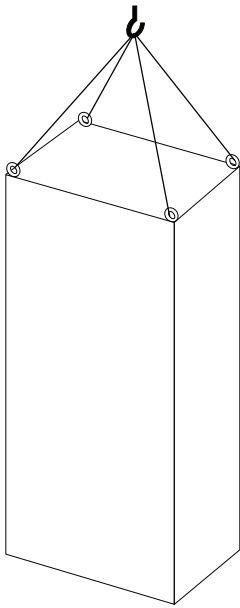

Illustration 9.4 Recommended Lifting Method for F8 Enclosure

130BF993.10

## 9.3 Operating Environment

In environments with airborne liquids, particles, or corrosive gases, ensure that the IP/Type rating of the equipment matches the installation environment. For specifications regarding ambient conditions, see *chapter 7.5 Ambient Conditions*.

### **NOTICE**

#### CONDENSATION

Moisture can condense on the electronic components and cause short circuits. Avoid installation in areas subject to frost. Install an optional space heater when the drive is colder than the ambient air. Operating in standby mode reduces the risk of condensation as long as the power dissipation keeps the circuitry free of moisture.

### **NOTICE**

#### EXTREME AMBIENT CONDITIONS

Hot or cold temperatures compromise unit performance and longevity.

- Do not operate in environments where the ambient temperature exceeds 55 °C (131 °F).
- The drive can operate at temperatures down to -10 °C (14 °F). However, proper operation at rated load is only guaranteed at 0 °C (32 °F) or higher.
- If temperature exceeds ambient temperature limits, extra air conditioning of the cabinet or installation site is required.

## 9.3.1 Gases

Aggressive gases, such as hydrogen sulphide, chlorine, or ammonia can damage the electrical and mechanical components. The unit uses conformal-coated circuit boards to reduce the effects of aggressive gases. For conformal-coating class specifications and ratings, see *chapter 7.5 Ambient Conditions*.

## 9.3.2 Dust

When installing the drive in dusty environments, pay attention to the following:

### Periodic maintenance

When dust accumulates on electronic components, it acts as a layer of insulation. This layer reduces the cooling capacity of the components, and the components become warmer. The hotter environment decreases the life of the electronic components.

Keep the heat sink and fans free from dust build-up. For more service and maintenance information, refer to the *operating guide*.

### Cooling fans

Fans provide airflow to cool the drive. When fans are exposed to dusty environments, the dust can damage the fan bearings and cause premature fan failure. Also, dust can accumulate on fan blades causing an imbalance which prevents the fans from properly cooling the unit.

## 9.3.3 Potentially Explosive Atmospheres

### **WARNING**

#### EXPLOSIVE ATMOSPHERE

Do not install the drive in a potentially explosive atmosphere. Install the unit in a cabinet outside of this area. Failure to follow this guideline increases risk of death or serious injury.

Systems operated in potentially explosive atmospheres must fulfill special conditions. EU Directive 94/9/EC (ATEX 95) classifies the operation of electronic devices in potentially explosive atmospheres.

- Class d specifies that if a spark occurs, it is contained in a protected area.
- Class e prohibits any occurrence of a spark.

### Motors with class d protection

Does not require approval. Special wiring and containment are required.

**Motors with class e protection**

When combined with an ATEX approved PTC monitoring device like the VLT® PTC Thermistor Card MCB 112, installation does not need an individual approval from an approbated organization.

**Motors with class d/e protection**

The motor itself has an e ignition protection class, while the motor cabling and connection environment is in compliance with the d classification. To attenuate the high peak voltage, use a sine-wave filter at the drive output.

**When using a drive in a potentially explosive atmosphere, use the following:**

- Motors with ignition protection class d or e.
- PTC temperature sensor to monitor the motor temperature.
- Short motor cables.
- Sine-wave output filters when shielded motor cables are not used.

**Mounting considerations:<sup>1)</sup>**

- Locate the unit as near to the motor as possible. See *chapter 7.6 Cable Specifications* for the maximum motor cable length.
- Ensure unit stability by mounting the unit to a solid surface.
- Ensure that the strength of the mounting location supports the unit weight.
- Ensure that there is enough space around the unit for proper cooling. Refer to *chapter 9.5 Cooling*.
- Ensure enough access to open the door.
- Ensure cable entry from the bottom.

1) For non-typical installation, contact the factory.

**NOTICE**

**MOTOR THERMISTOR SENSOR MONITORING**

Drives with the VLT® PTC Thermistor Card MCB 112 option are PTB-certified for potentially explosive atmospheres.

9

**9.4 Mounting Configurations**

Table 9.1 lists the available mounting configurations for each enclosure. For specific panel/wall mounting or pedestal mounting installation instructions, see the *operating guide*. See also *chapter 8 Exterior and Terminal Dimensions*.

**NOTICE**

Improper mounting can result in overheating and reduced performance.

Enclosure	Panel/wall mounting	Pedestal mounting (Standalone)
E1	–	X
E2	X	–
F1	–	X
F2	–	X
F3	–	X
F4	–	X
F8	–	X
F9	–	X
F10	–	X
F11	–	X
F12	–	X
F13	–	X

Table 9.1 Mounting Configurations

## 9.5 Cooling

### **NOTICE**

Improper mounting can result in overheating and reduced performance. For proper mounting, refer to *chapter 8 Exterior and Terminal Dimensions*.

- Ensure that top and bottom clearance for air cooling is provided. Clearance requirement: 225 mm (9 in).
- Provide sufficient airflow flow rate. See *Table 9.2*.
- Consider derating for temperatures starting between 45 °C (113 °F) and 50 °C (122 °F) and elevation 1000 m (3300 ft) above sea level. See *chapter 9.6 Derating* for detailed information on derating.

The drive utilizes a back-channel cooling concept that removes heat sink cooling air. The heat sink cooling air carries approximately 90% of the heat out of the back channel of the drive. Redirect the back-channel air from the panel or room by using:

- **Duct cooling**  
Back-channel cooling kits are available to direct the heat sink cooling air out of the panel when IP20/Chassis drives are installed in Rittal enclosures. Use of these kits reduce the heat in the panel and smaller door fans can be specified.
- **Back-wall cooling**  
Installing top and base covers to the unit allows the back-channel cooling air to be ventilated out of the room.

### **NOTICE**

A door fan is required on the enclosure to remove the heat losses not contained in the back channel of the drive and those losses generated from other components installed inside the enclosure. The total required airflow must be calculated so that the appropriate fan is selected. Some enclosure manufacturers offer software for performing airflow calculations.

Secure the necessary airflow over the heat sink.

Enclosure	Models		Door fan/top fan [m <sup>3</sup> /hr (cfm)]	Heat sink fan [m <sup>3</sup> /hr (cfm)]
	380–480 V	525–690 V		
E1	–	P450–P500	340 (200)	1105 (650)
E2			255 (150)	1105 (650)
E1	P355–P450	P560–P630	340 (200)	1445 (850)
E2			255 (150)	1445 (850)

Table 9.2 E1–E2 Airflow Rate

Enclosure	Protection type	Door fan/top fan [m <sup>3</sup> /hr (cfm)]	Heat sink fan [m <sup>3</sup> /hr (cfm)]
F1–F4	IP21/Type 1	700 (412)	985 (580)
	IP54/Type 12	525 (309)	985 (580)
F8–F13	IP21/Type 1	700 (412)	985 (580)
	IP54/Type 12	525 (309)	985 (580)

Table 9.3 F1–F4 and F8–F13 Airflow Rates

### 9.5.1 External Ducting and Derating

If more duct work is added externally to the Rittal cabinet, the pressure drop in the ducting must be calculated using *Illustration 9.5 – Illustration 9.7.*

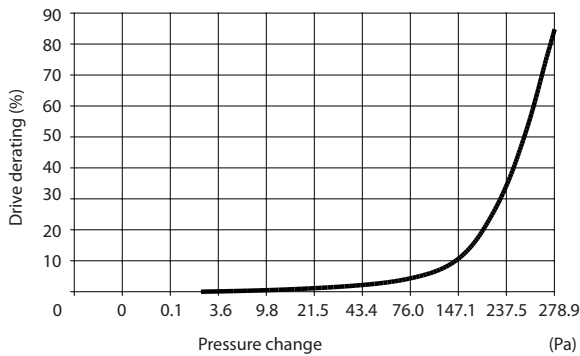

e30bb010.10

**Illustration 9.5 Derating vs. Pressure Change for E1-E2 Enclosures, 380-480 V Models: P315 and 525-690 V Models: P450-P500. Airflow: 650 cfm (1105 m<sup>3</sup>/h)**

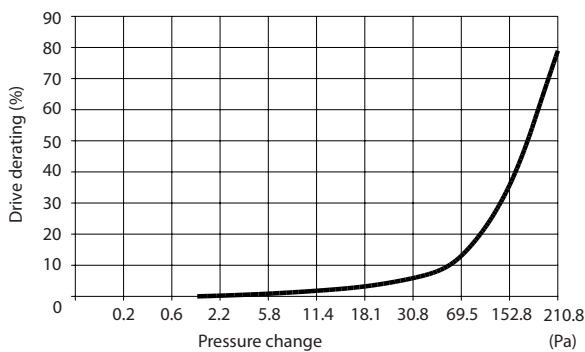

e30bb011.10

**Illustration 9.6 Derating vs. Pressure Change for E1-E2 Enclosures, 380-480 V Models: P355-P450 and 525-690 V Models: P560-P630. Airflow: 850 cfm (1445 m<sup>3</sup>/h)**

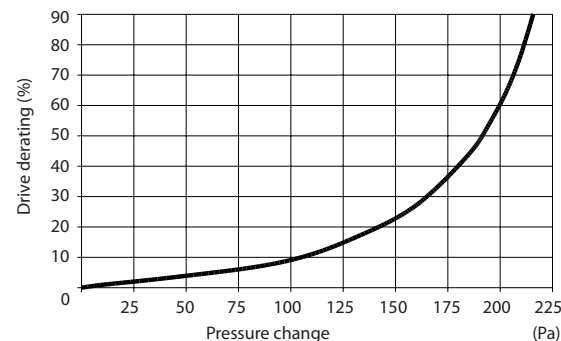

e30bb190.10

**Illustration 9.7 Derating vs. Pressure Change for Enclosures F1-F4. Airflow: 580 cfm (985 m<sup>3</sup>/h)**

### 9.6 Derating

Derating is a method used to reduce output current to avoid tripping the drive when high temperatures are reached within the enclosure. If certain extreme operating conditions are expected, a higher-powered drive can be selected to eliminate the need for derating. This is called manual derating. Otherwise, the drive automatically derates the output current to eliminate the excessive heat generated by extreme conditions.

#### Manual derating

When the following conditions are present, Danfoss recommends selecting a drive 1 power size higher (for example P710 instead of P630):

- Low-speed – continuous operation at low RPM in constant torque applications.
- Low air pressure – operating at altitudes above 1000 m (3281 ft).
- High ambient temperature – operating at ambient temperatures of 10 °C (50 °F).
- High switching frequency.
- Long motor cables.
- Cables with a large cross-section.

#### Automatic derating

If the following operating conditions are found, the drive automatically changes switching frequency or switching pattern (PWM to SFAVM) to reduce excessive heat within the enclosure:

- High temperature on the control card or heat sink.
- High motor load or low motor speed.
- High DC-link voltage.

#### **NOTICE**

Automatic derating is different when parameter 14-55 Output Filter is set to [2] Sine-Wave Filter Fixed.

### 9.6.1 Derating for Low-Speed Operation

When a motor is connected to a drive, it is necessary to check that the cooling of the motor is adequate. The level of cooling required depends on the following:

- Load on the motor.
- Operating speed.
- Length of operating time.

#### Constant torque applications

A problem can occur at low RPM values in constant torque applications. In a constant torque application, a motor can overheat at low speeds because less cooling air is being provided by the fan within the motor.

If the motor is run continuously at an RPM value lower than half of the rated value, the motor must be supplied with extra air cooling. If extra air cooling cannot be provided, a motor designed for low RPM/constant torque applications can be used instead.

#### Variable (quadratic) torque applications

Extra cooling or derating of the motor is not required in variable torque applications where the torque is proportional to the square of the speed, and the power is proportional to the cube of the speed. Centrifugal pumps and fans are common variable torque applications.

### 9.6.2 Derating for Altitude

The cooling capability of air is decreased at lower air pressure. No derating is necessary at or below 1000 m (3281 ft). Above 1000 m (3281 ft), the ambient temperature ( $T_{AMB}$ ) or maximum output current ( $I_{MAX}$ ) should be derated. Refer to *Illustration 9.8*.

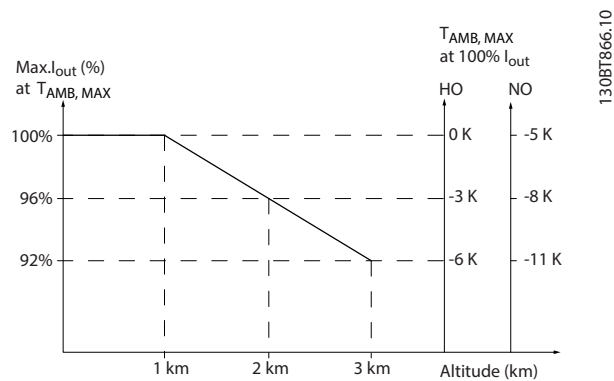

Illustration 9.8 Derating of Output Current Based on Altitude at  $T_{AMB,MAX}$

*Illustration 9.8* shows that at 41.7 °C (107 °F), 100% of the rated output current is available. At 45 °C (113 °F) ( $T_{AMB, MAX}$ -3 K), 91% of the rated output current is available.

### 9.6.3 Derating for Ambient Temperature

Graphs are presented individually for 60° AVM and SFAVM. 60° AVM only switches 2/3 of the time, whereas SFAVM switches throughout the whole period. The maximum switching frequency is 16 kHz for 60° AVM and 10 kHz for SFAVM. The discrete switching frequencies are presented in *Table 9.4* and *Table 9.5*.

Model	Switching pattern	High overload HO, 150%	Normal overload NO, 110%
P355 to P1M0 380–480 V	60 AVM		
	SFAVM		

Table 9.4 Ambient Temperature Derating Tables for E1–E2, F1–F4, and F8–F13 Enclosures, 380–480 V

Model	Switching pattern	High overload HO, 150%	Normal overload NO, 110%
P450 to P1M4 525–690 V	60 AVM		
	SFAVM		

Table 9.5 Ambient Temperature Derating Tables for E1–E2, F1–F4, and F8–F13 Enclosures, 525–690 V

## 10 Electrical Installation Considerations

### 10.1 Safety Instructions

See *chapter 2 Safety* for general safety instructions.

#### **⚠ WARNING**

##### INDUCED VOLTAGE

Induced voltage from output motor cables from different drives that are run together can charge equipment capacitors even with the equipment turned off and locked out. Failure to run output motor cables separately or use shielded cables could result in death or serious injury.

- Run output motor cables separately or use shielded cables.
- Simultaneously lock out all the drives.

#### **⚠ WARNING**

##### SHOCK HAZARD

The drive can cause a DC current in the ground conductor and thus result in death or serious injury.

- When a residual current-operated protective device (RCD) is used for protection against electrical shock, only an RCD of Type B is allowed on the supply side.

Failure to follow the recommendation means that the RCD cannot provide the intended protection.

##### Overcurrent protection

- Extra protective equipment such as short-circuit protection or motor thermal protection between drive and motor is required for applications with multiple motors.
- Input fusing is required to provide short circuit and overcurrent protection. If fuses are not factory-supplied, the installer must provide them. See maximum fuse ratings in *chapter 10.5 Fuses and Circuit Breakers*.

##### Wire type and ratings

- All wiring must comply with local and national regulations regarding cross-section and ambient temperature requirements.
- Power connection wire recommendation: Minimum 75 °C (167 °F) rated copper wire.

See *chapter 7.6 Cable Specifications* for recommended wire sizes and types.

#### **⚠ CAUTION**

##### PROPERTY DAMAGE

Protection against motor overload is not included in the default setting. To add this function, set *parameter 1-90 Motor Thermal Protection* to [ETR trip] or [ETR warning]. For the North American market, the ETR function provides class 20 motor overload protection in accordance with NEC. Failure to set *parameter 1-90 Motor Thermal Protection* to [ETR trip] or [ETR warning] means that motor overload protection is not provided and, if the motor overheats, property damage can occur.

10.2 Wiring Schematic

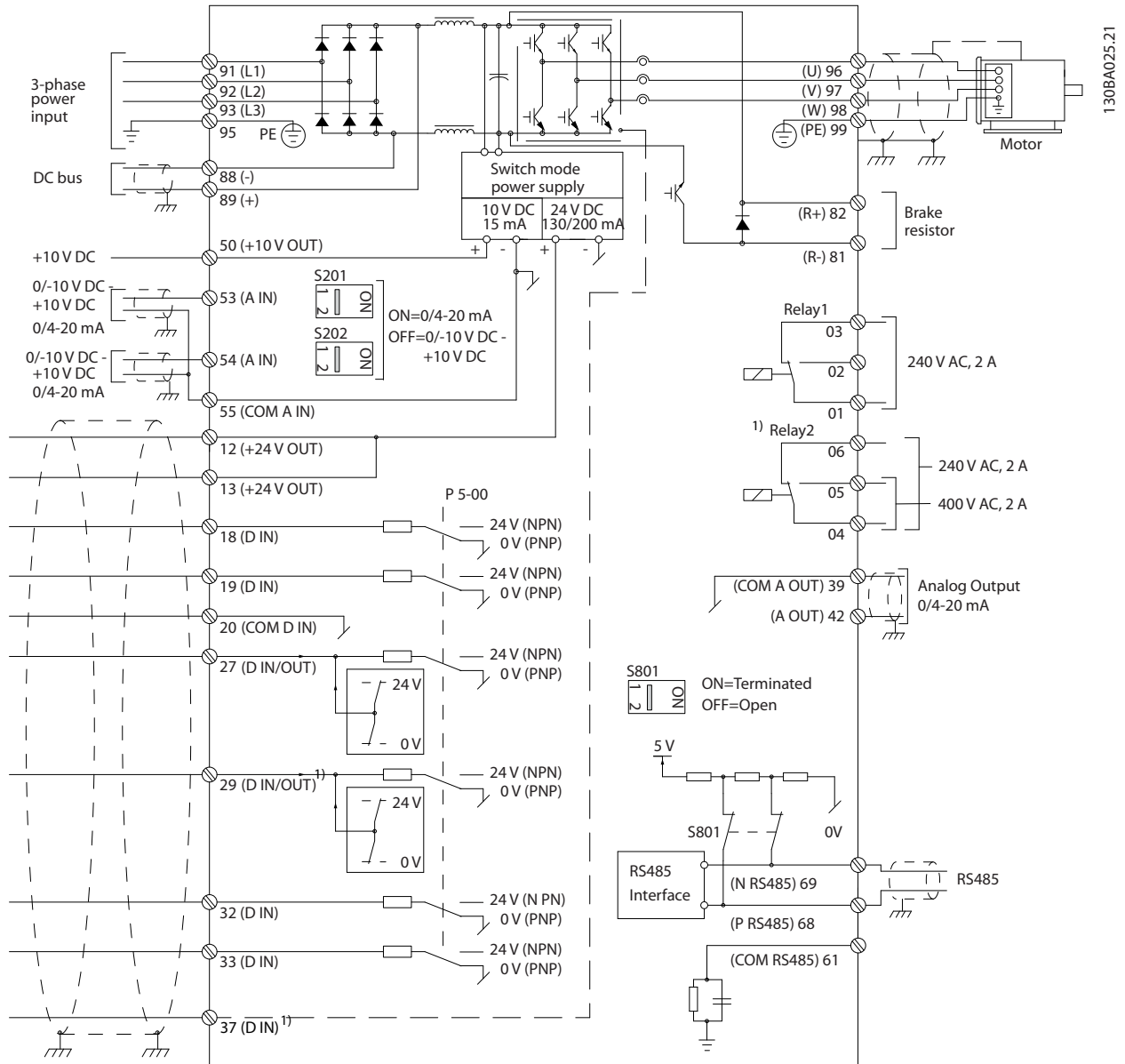

Illustration 10.1 Basic Wiring Schematic

A=Analog, D=Digital

1) Terminal 37 (optional) is used for Safe Torque Off. For Safe Torque Off installation instructions, refer to the Safe Torque Off Operating Guide.



### 10.3 Connections

#### 10.3.1 Power Connections

**NOTICE**

All cabling must comply with national and local regulations on cable cross-sections and ambient temperature. UL applications require 75 °C (167 °F) copper conductors. Non-UL applications can use 75 °C (167 °F) and 90 °C (194 °F) copper conductors.

The power cable connections are located as shown in *Illustration 10.2*. See *chapter 7.6 Cable Specifications* for correct dimensioning of motor cable cross-section and length.

For protection of the drive, use the recommended fuses unless the unit has built-in fuses. Recommended fuses are listed in *chapter 10.5 Fuses and Circuit Breakers*. Ensure that proper fusing complies with local regulations.

The connection of mains is fitted to the mains switch if included.

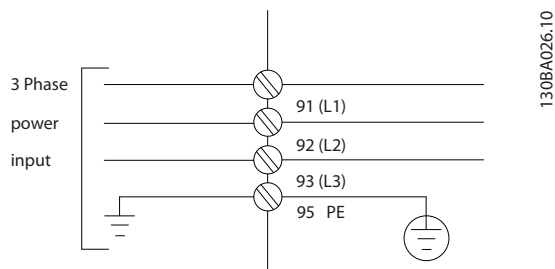

**Illustration 10.2** Connection of Mains, Enclosures E1-E2 and F1-F4

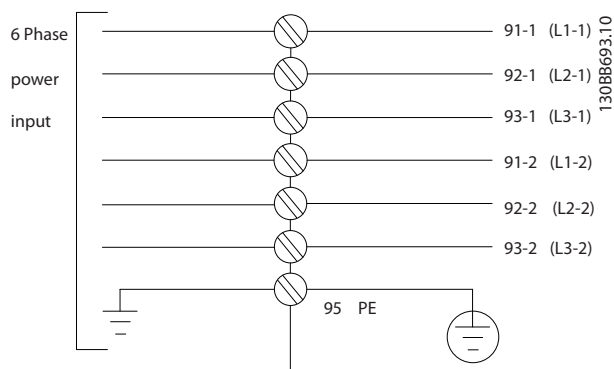

**Illustration 10.3** Connection of Mains, Enclosures F8-F13

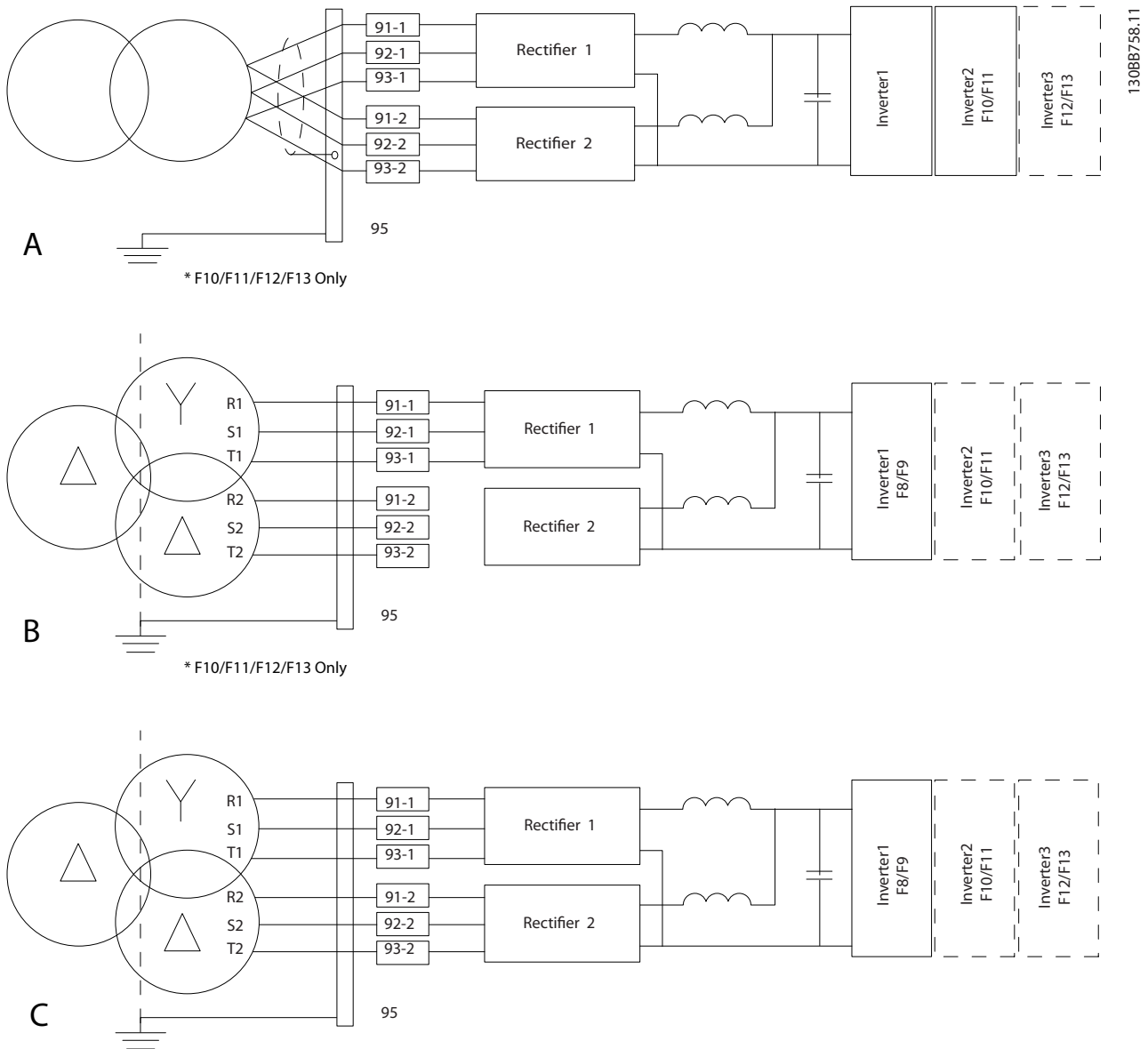

10

A	6-pulse connection <sup>1), 2), 3)</sup>
B	Modified 6-pulse connection <sup>2), 3), 4)</sup>
C	12-pulse connection <sup>3), 5)</sup>

Illustration 10.4 Connection of Mains Options for 12-pulse Drives

- 1) Parallel connection shown. A single 3-phase cable can be used with sufficient carrying capability. Install shorting busbars.
- 2) 6-pulse connection eliminates the harmonics reduction benefits of the 12-pulse rectifier.
- 3) Suitable for IT and TN connection of mains.
- 4) If 1 of the 6-pulse modular rectifiers becomes inoperable, it is possible to operate the drive at reduced load with a single 6-pulse rectifier. Contact Danfoss for reconnection details.
- 5) No paralleling of mains cabling is shown here. A 12-pulse drive used as a 6-pulse should have mains cables of equal numbers and lengths.

Shielding of cables

**NOTICE**

The motor cable must be shielded. If an unshielded cable is used, some EMC requirements are not complied with. Use a shielded motor cable to comply with EMC emission specifications. For more information, see *chapter 10.16 EMC-compliant Installation*.

Avoid installation with twisted shield ends (pigtailed). They spoil the shielding effect at higher frequencies. If it is necessary to break the shield, continue the shield at the lowest possible HF impedance.

Connect the motor cable shield to both the decoupling plate of the drive and the metal housing of the motor. Make the shield connections with the largest possible surface area (cable clamp) by using the installation devices within the drive.

Cable length and cross-section

The drive has been EMC tested with a given length of cable. Keep the motor cable as short as possible to reduce the noise level and leakage currents.

Switching frequency

When drives are used together with sine-wave filters to reduce the acoustic noise from a motor, the switching frequency must be set according to the instructions in *parameter 14-01 Switching Frequency*.

Terminals				Connection type
96	97	98	99	
U	V	W	PE <sup>1)</sup>	Motor voltage 0–100% of mains voltage. 3 wires out of motor.
U1	V1	W1	PE <sup>1)</sup>	Delta-connected.
W2	U2	V2		6 wires out of motor.
U1	V1	W1	PE <sup>1)</sup>	Star-connected U2, V2, W2. U2, V2, and W2 to be interconnected separately.

Table 10.1 Motor Cable Connections, Enclosures E1–E2 and F1–F4

1) Protected ground connection

Terminals				Connection type
96	97	98	99	
U	V	W	PE <sup>1)</sup>	Motor voltage 0–100% of mains voltage. 3 wires out of motor.
U1	V1	W1	PE <sup>1)</sup>	Delta-connected.
W2	U2	V2		6 wires out of motor.
U1	V1	W1	PE <sup>1)</sup>	Star-connected U2, V2, W2. U2, V2, and W2 to be interconnected separately.

Table 10.2 Motor Cable Connections, Enclosures F8–F13

1) Protective ground connection

**NOTICE**

In motors without phase insulation, paper, or other insulation reinforcement suitable for operation with voltage supply, use a sine-wave filter on the output of the drive.

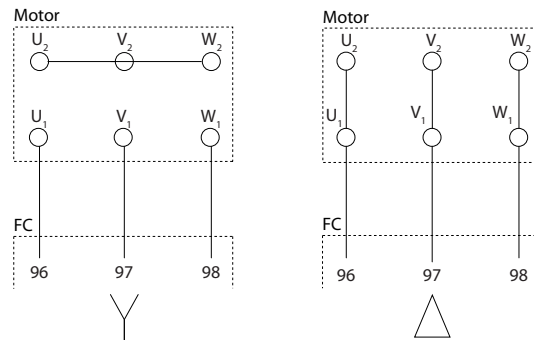

Illustration 10.5 Motor Cable Connection

175ZA114.11

10.3.2 DC Bus Connection

The DC bus terminal is used for DC back-up, with the DC link being supplied from an external source.

Terminal	Function
88, 89	DC Bus

Table 10.3 DC Bus Terminals

10.3.3 Load Sharing Connection

Load sharing links together the DC intermediate circuits of several drives. For an overview, see *chapter 5.6 Load Share Overview*.

The load sharing feature requires extra equipment and safety considerations. Consult Danfoss for ordering and installation recommendations.

Terminal	Function
88, 89	Load sharing

Table 10.4 Load Sharing Terminals

The connection cable must be shielded and the maximum length from the drive to the DC bar is limited to 25 m (82 ft).

### 10.3.4 Brake Cable Connection

The connection cable to the brake resistor must be shielded and the maximum length from the drive to the DC bar is limited to 25 m (82 ft).

- Use cable clamps to connect the shield to the conductive backplate on the drive and to the metal cabinet of the brake resistor.
- Size the brake cable cross-section to match the brake torque.

Terminal	Function
81, 82	Brake resistor terminals

Table 10.5 Brake Resistor Terminals

See the *VLT® Brake Resistor MCE 101 Design Guide* for more details.

#### **NOTICE**

If a short circuit in the brake module occurs, prevent excessive power dissipation in the brake resistor by using a mains switch or contactor to disconnect the mains from the drive.

### 10.3.5 Transformer Connection

Transformers used along with 12-pulse drives (F8–F13) must conform to the following specifications.

Loading is based on 12-pulse K-4 rated transformer with 0.5% voltage and impedance balance between secondary windings. Leads from the transformer to the input terminals on the drive are required to be equal length within 10%.

Connection	Dy11 d0 or Dyn 11d0
Phase shift between secondaries	30°
Voltage difference between secondaries	<0.5%
Short-circuit impedance of secondaries	>5%
Short-circuit impedance difference between secondaries	<5% of short-circuit impedance
Other	No grounding of the secondaries allowed. Static shield recommended

### 10.3.6 External Fan Supply Connection

In case the drive is supplied by DC or the fan must run independently of the mains supply, an external supply can be connected via the power card.

The connector, which is on the power card, connects the mains voltage to the cooling fans. The fans are configured at the factory to connect to a common AC line. Use jumpers between terminals 100–102 and 101–103. If external supply is needed, the jumpers are removed and the supply is connected to terminals 100 and 101. Use a 5 A fuse for protection. In UL applications, use a Littelfuse KLK-5 or equivalent.

Terminal	Function
100, 101	Auxiliary supply S, T
102, 103	Internal supply S, T

Table 10.6 External Supply

### 10.3.7 Personal Computer Connection

To control the drive from a PC, install the MCT 10 Set-up Software. The PC is connected via a standard (host/device) USB cable, or via the RS485 interface as shown in the section *Bus Connection* in the *programming guide*.

USB is a universal serial bus utilizing 4 shielded wires with ground pin 4 connected to the shield in the PC USB port. All standard PCs are manufactured without galvanic isolation in the USB port.

To prevent damage to the USB host controller through the shield of the USB cable, follow the ground recommendations described in the *operating guide*.

When connecting the PC to the drive through a USB cable, Danfoss recommends using a USB isolator with galvanic isolation to protect the PC USB host controller from ground potential differences. It is also recommended not to use a PC power cable with a ground plug when the PC is connected to the drive through a USB cable. These recommendations reduce the ground potential difference, but does not eliminate all potential differences due to the ground and shield connected in the PC USB port.

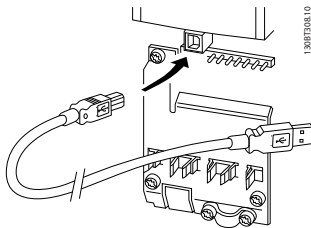
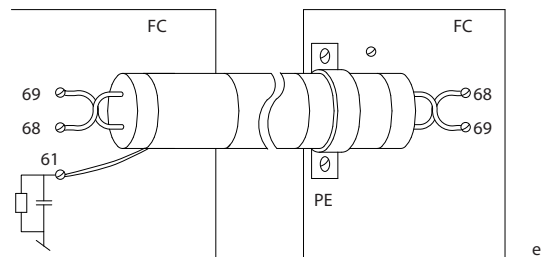
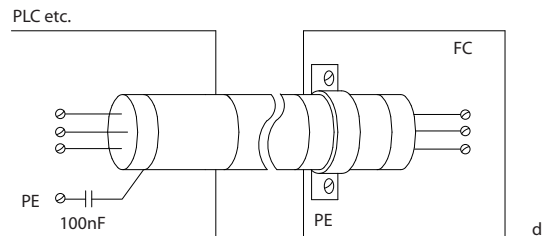
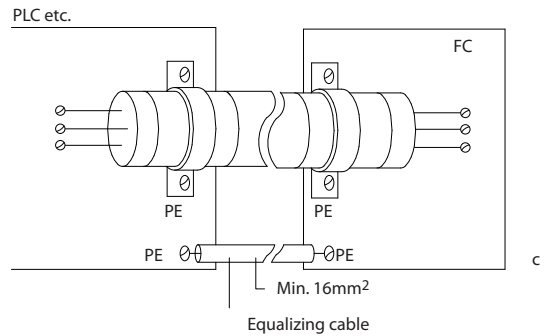
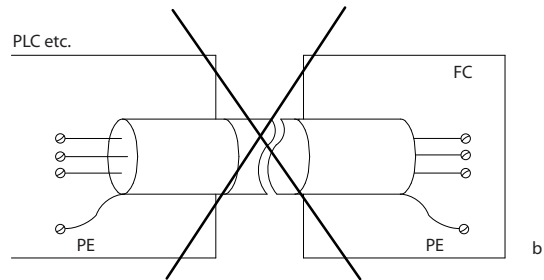
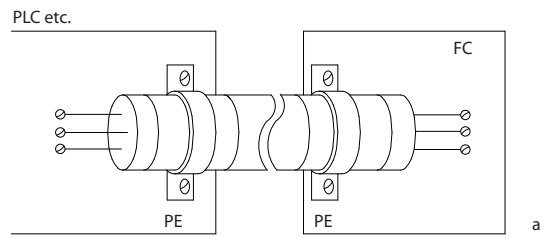

Illustration 10.6 USB Connection

### 10.4 Control Wiring and Terminals

Control cables must be shielded and the shield must be connected with a cable clamp at both ends to the metal cabinet of the unit.

For correct grounding of control cables, see *Illustration 10.7*.



130BA051.11

a	Control cables and serial communication cables must be fitted with cable clamps at both ends to ensure the best possible electrical contact.
b	Do not use twisted cable ends (pigtails). They increase the shield impedance at high frequencies.

c	If the ground potential between the drive and the PLC is different, electric noise can occur that disturbs the entire system. Fit an equalizing cable next to the control cable. Minimum cable cross-section: 16 mm <sup>2</sup> (6 AWG).
d	If long control cables are used, 50/60 Hz ground loops are possible. Connect 1 end of the shield to ground via a 100 nF capacitor (keeping leads short).
e	When using cables for serial communication, eliminate low-frequency noise currents between 2 drives by connecting 1 end of the shield to terminal 61. This terminal is connected to ground via an internal RC link. Use twisted-pair cables for reducing the differential mode interference between the conductors.

Illustration 10.7 Grounding Examples

### 10.4.1 Control Cable Routing

Tie down and route all control wires as shown in *Illustration 10.8* and *Illustration 10.9*. Remember to connect the shields in a proper way to ensure optimum electrical immunity.

- Isolate control wiring from high-power cables.
- When the drive is connected to a thermistor, ensure that the thermistor control wiring is shielded and reinforced/double insulated. A 24 V DC supply voltage is recommended.

#### Fieldbus connection

Connections are made to the relevant options on the control card. See the relevant fieldbus instruction. The cable must be tied down and routed along with other control wires inside the unit. See *Illustration 10.8* and *Illustration 10.9*.

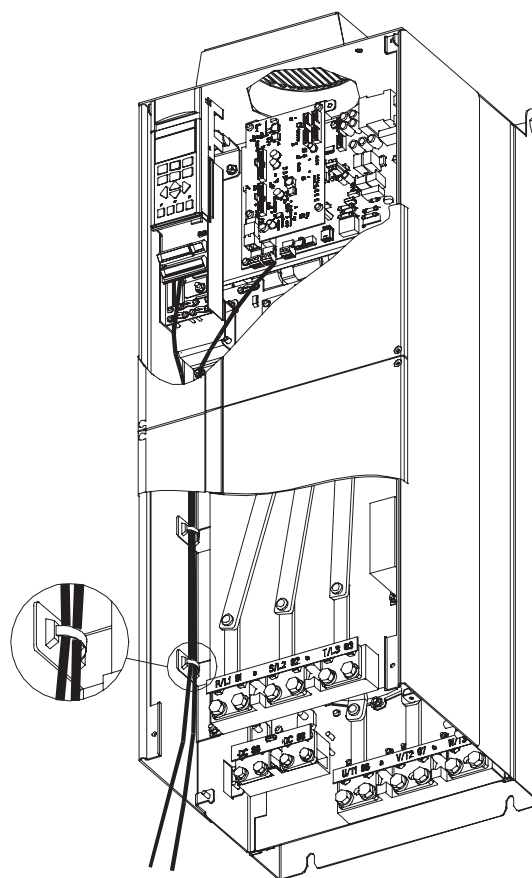
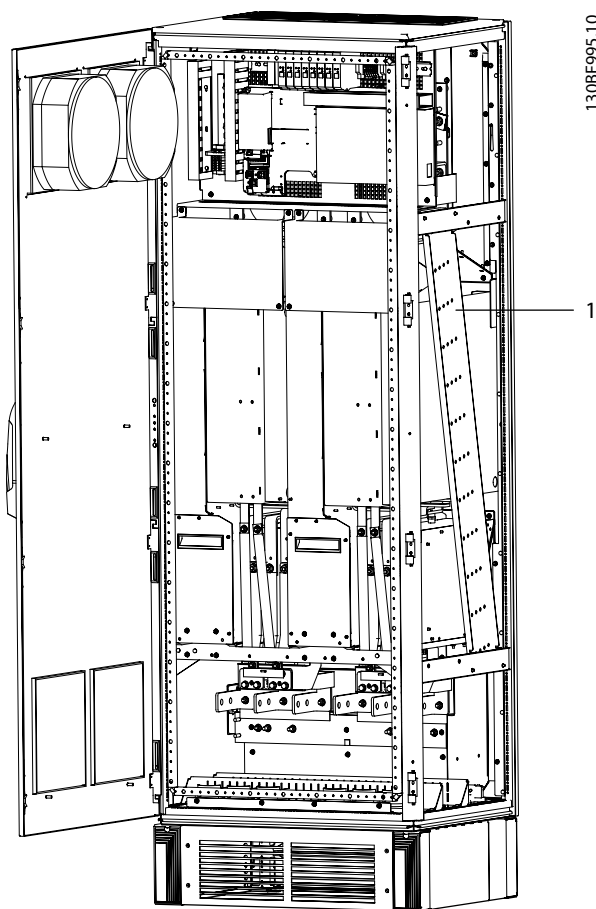

Illustration 10.8 Control Card Wiring Path for the E1 and E2 Enclosures

130BF994.10



1 Cable tray for routing control cables in F1-F13 enclosures

Illustration 10.9 Control Card Wiring Path for the F1/F3. Control Card Wiring for the F2/F4 and F8-F13 Use the Same Path

In the enclosure E drives, it is possible to connect the fieldbus from the top of the unit, as shown in the following illustrations. On the IP21/54 (NEMA-1/NEMA-12) unit, a cover plate must be removed. The kit number for the fieldbus top connection is 176F1742.

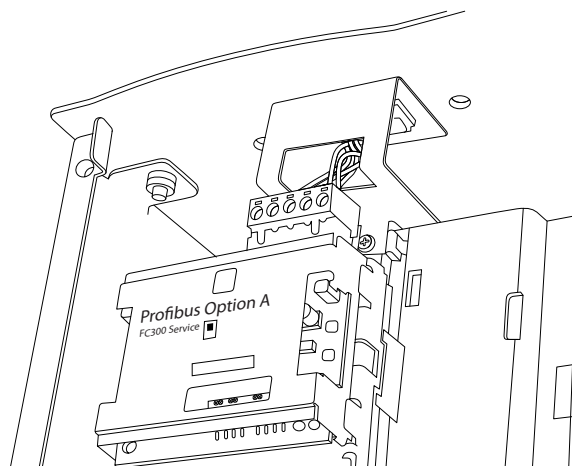

Illustration 10.10 Top Connection for Fieldbus

### 10.4.2 Control Terminals

Illustration 10.11 shows the removable drive connectors. Terminal functions and default settings are summarized in Table 10.7 – Table 10.9.

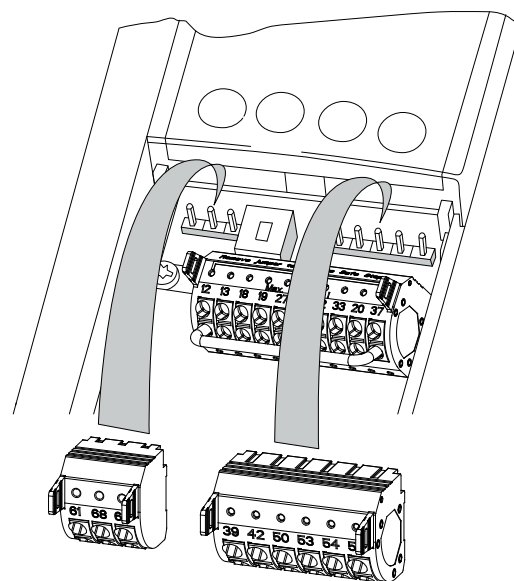
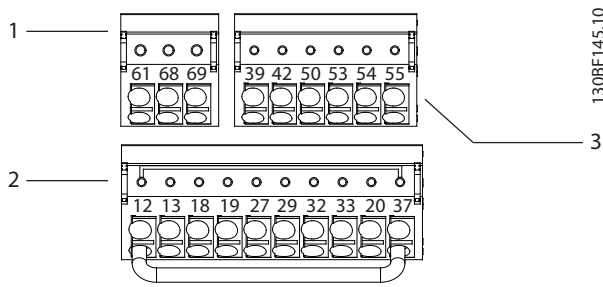

Illustration 10.11 Control Terminal Locations



1	Serial communication terminals
2	Digital input/output terminals
3	Analog input/output terminals

Illustration 10.12 Terminal Numbers Located on the Connectors

Serial communication terminals			
Terminal	Parameter	Default setting	Description
61	-	-	Integrated RC-filter for cable shield. ONLY for connecting the shield if there are EMC problems.
68 (+)	Parameter group 8-3* FC Port Settings	-	RS485 interface. A switch (BUS TER.) is provided on the control card for bus termination resistance.
69 (-)	Parameter group 8-3* FC Port Settings	-	
Relays			
01, 02, 03	Parameter 5-40 Function Relay [0]	[0] No operation	Form C relay output. For AC or DC voltage and resistive or inductive loads.
04, 05, 06	Parameter 5-40 Function Relay [1]	[0] No operation	

Table 10.7 Serial Communication Terminal Descriptions

Digital input/output terminals			
Terminal	Parameter	Default setting	Description
12, 13	-	+24 V DC	24 V DC supply voltage for digital inputs and external transducers. Maximum output current 200 mA for all 24 V loads.

Digital input/output terminals			
Terminal	Parameter	Default setting	Description
18	Parameter 5-10 Terminal 18 Digital Input	[8] Start	Digital inputs.
19	Parameter 5-11 Terminal 19 Digital Input	[10] Reversing	
32	Parameter 5-14 Terminal 32 Digital Input	[0] No operation	For digital input or output. Default setting is input.
33	Parameter 5-15 Terminal 33 Digital Input	[0] No operation	
27	Parameter 5-12 Terminal 27 Digital Input	[2] Coast inverse	
29	Parameter 5-13 Terminal 29 Digital Input	[14] JOG	Common for digital inputs and 0 V potential for 24 V supply.
20	-	-	
37	-	STO	When not using the optional STO feature, a jumper wire is required between terminal 12 (or 13) and terminal 37. This set-up allows the drive to operate with factory default programming values.

Table 10.8 Digital Input/Output Terminal Descriptions

Analog input/output terminals			
Terminal	Parameter	Default setting	Description
39	-	-	Common for analog output.
42	Parameter 6-50 Terminal 42 Output	[0] No operation	Programmable analog output. 0–20 mA or 4–20 mA at a maximum of 500 Ω.
50	-	+10 V DC	10 V DC analog supply voltage for potentiometer or thermistor. 15 mA maximum.



Analog input/output terminals			
Terminal	Parameter	Default setting	Description
53	Parameter group 6-1* Analog Input 1	Reference	Analog input. For voltage or current. Switches A53 and A54 select mA or V.
54	Parameter group 6-2* Analog Input 2	Feedback	
55	-	-	Common for analog input.

Table 10.9 Analog Input/Output Terminal Descriptions

Relay terminals:

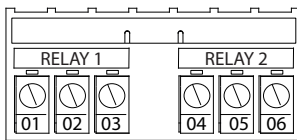

Illustration 10.13 Relay 1 and Relay 2 Terminals

- Relay 1 and relay 2. The location of the outputs depends on the drive configuration. See the *operating guide*.
- Terminals on built-in optional equipment. See the instructions provided with the equipment option.

10.4.3 Input Polarity of Control Cables

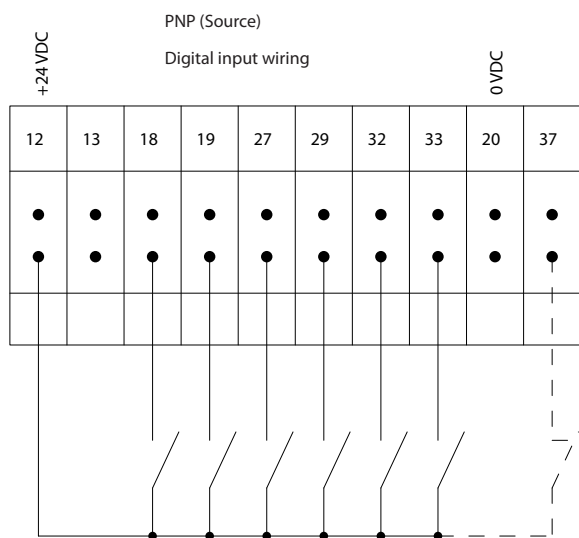

Illustration 10.14 Input Polarity of Control Terminals (PNP Source)

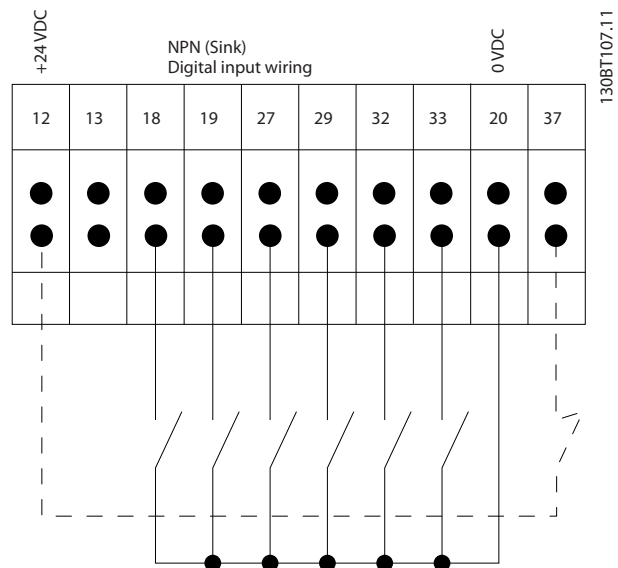

Illustration 10.15 Input Polarity of Control Terminals (NPN Sink)

**NOTICE**

Use shielded cables to comply with EMC emission specifications. For more information, see *chapter 10.16 EMC-compliant Installation*.

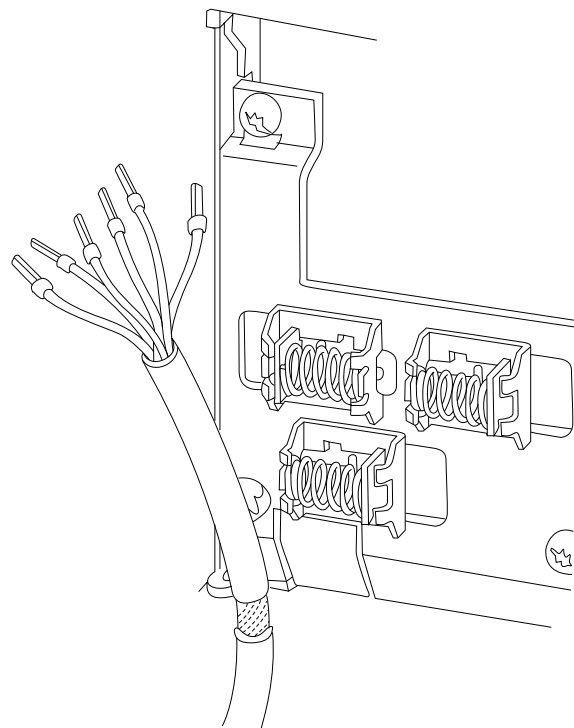
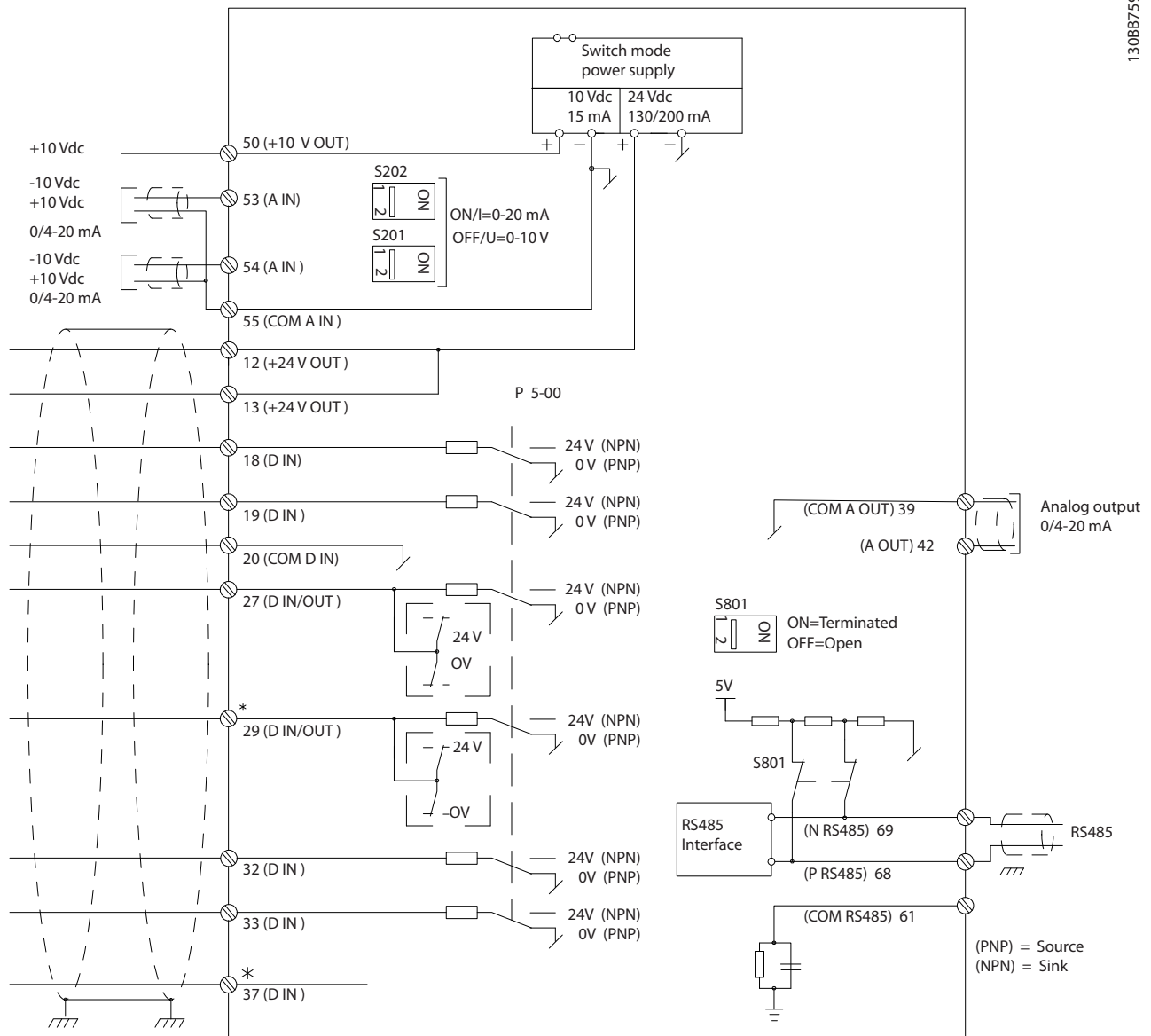

Illustration 10.16 Shield Termination and Strain Relief of Control Cable

10.4.4 12-pulse Control Terminals

13088759.11



10

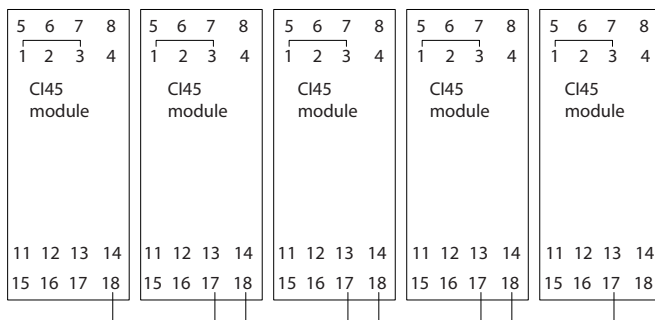

Illustration 10.17 12-pulse Control Terminals

## 10.5 Fuses and Circuit Breakers

Fuses ensure that possible damage to the drive is limited to damages inside the drive. To ensure compliance with EN 50178, use the recommended fuses as replacements. Use of fuses on the supply side is mandatory for IEC 60364 (EC) and NEC 2009 (UL) compliant installations.

### Branch circuit protection

To protect the installation against electrical and fire hazard, all branch circuits in an installation, such as those branch circuits found in switchgear and machines, must be protected against short circuit and overcurrent according to national/international regulations.

Fuses or circuit breakers are mandatory to comply with IEC 60364.

Enclosure	Model	Recommended fuse size	Recommended maximum fuse
E	P315	aR-900	aR-900
	P355	aR-900	aR-900
	P400	aR-900	aR-900
	P450	aR-900	aR-900
F	P500	aR-1600	aR-1600
	P500	aR-2000	aR-2000
	P560	aR-2500	aR-2500
	P630	aR-2500	aR-2500
	P710	aR-2500	aR-2500
	P1000	aR-2500	aR-2500

Table 10.10 Recommended Fuses for CE Compliance, 380–480 V

Enclosure	Model	Recommended fuse size	Recommended maximum fuse
E	P450	aR-700	aR-700
	P500	aR-900	aR-900
	P560		
	P630		
F	P710	aR-1600	aR-1600
	P800	aR-2000	aR-2000
	P900	aR-2500	aR-2500
	P1M0		
	P1M2		
	P1M4		

Table 10.11 Recommended Fuses for CE Compliance, 525–690 V

### 10.5.1 Power/semiconductor Fuse Options

Model	Recommended drive external fuse Bussmann PN	Rating	Drive internal option Bussmann PN	Alternate external Siba PN	Alternate external Ferraz Shawmut PN
P315	170M6013	900 A, 700 V	170M6013	22 610 32.900	6.9URD33D08A0900
P355	170M6013	900 A, 700 V	170M6013	22 610 32.900	6.9URD33D08A0900
P400	170M6013	900 A, 700 V	170M6013	22 610 32.900	6.9URD33D08A0900

Table 10.12 380–480 V, Enclosure E, Mains Fuse Options for UL Compliance

Model	Recommended drive external fuse Bussmann PN	Rating	Drive internal option Bussmann PN	Alternate Siba PN
P450	170M7081	1600 A, 700 V	170M7082	20 695 32.1600
P500	170M7081	1600 A, 700 V	170M7082	20 695 32.1600
P560	170M7082	2000 A, 700 V	170M7082	20 695 32.2000
P630	170M7082	2000 A, 700 V	170M7082	20 695 32.2000
P710	170M7083	2500 A, 700 V	170M7083	20 695 32.2500
P800	170M7083	2500 A, 700 V	170M7083	20 695 32.2500

Table 10.13 380–480 V, Enclosure F, Mains Fuse Options for UL Compliance

Model	Drive internal Bussmann PN	Rating	Alternate Siba PN
P450	170M8611	1100 A, 1000 V	20 781 32.1000
P500	170M8611	1100 A, 1000 V	20 781 32.1000
P560	170M6467	1400 A, 700 V	20 681 32.1400
P630	170M6467	1400 A, 700 V	20 681 32.1400
P710	170M8611	1100 A, 1000 V	20 781 32.1000
P800	170M6467	1400 A, 700 V	20 681 32.1400

Table 10.14 380-480 V, Enclosure F, Inverter Module DC Link Fuses

#### **NOTICE**

For UL Compliance, the Bussmann 170M series fuses must be used for units supplied without a contactor-only option. For units supplied with a contactor-only option, see *Table 10.31* for SCCR ratings and UL fuse criteria.

Model	Recommended drive external fuse Bussmann PN	Rating	Drive internal option Bussmann PN	Alternate external Siba PN	Alternate external Ferraz Shawmut PN
P355	170M4017	700 A, 700 V	170M4017	20 610 32.700	6.9URD31D08A0700
P400	170M4017	700 A, 700 V	170M4017	20 610 32.700	6.9URD31D08A0700
P500	170M6013	900 A, 700 V	170M6013	22 610 32.900	6.9URD33D08A0900
P560	170M6013	900 A, 700 V	170M6013	22 610 32.900	6.9URD33D08A0900

Table 10.15 525–690 V, Enclosure E, Mains Fuse Options for UL Compliance

Model	Recommended drive external fuse Bussmann PN	Rating	Drive internal option Bussmann PN	Alternate Siba PN
P630	170M7081	1600 A, 700 V	170M7082	20 695 32.1600
P710	170M7081	1600 A, 700 V	170M7082	20 695 32.1600
P800	170M7081	1600 A, 700 V	170M7082	20 695 32.1600
P900	170M7081	1600 A, 700 V	170M7082	20 695 32.1600
P1000	170M7082	2000 A, 700 V	170M7082	20 695 32.2000
P1200	170M7083	2500 A, 700 V	170M7083	20 695 32.2500

Table 10.16 525–690 V, Enclosure F, Mains Fuse Options for UL Compliance

Model	Drive internal Bussmann PN	Rating	Alternate Siba PN
P630	170M8611	1100 A, 1000 V	20 781 32.1000
P710	170M8611	1100 A, 1000 V	20 781 32.1000
P800	170M8611	1100 A, 1000 V	20 781 32.1000
P900	170M8611	1100 A, 1000 V	20 781 32.1000
P1000	170M8611	1100 A, 1000 V	20 781 32.1000
P1200	170M8611	1100 A, 1000 V	20 781 32.1000

Table 10.17 525–690 V, Enclosure F, Inverter Module DC Link Fuses

The 170M fuses from Bussmann shown use the -/80 visual indicator. -TN/80 Type T, -/110, or TN/110 Type T indicator fuses of the same size and amperage can be substituted for external use. To meet UL requirements, use any minimum 500 V UL listed fuse with associated current rating.

### 10.5.2 Supplementary Fuses

Enclosure	Bussmann PN	Rating
E and F	KTK-4	4 A, 600 V

Table 10.18 SMPS Fuse

Size/type	Bussmann PN	Littelfuse	Rating
P355–P400, 525–690 V	KTK-4	–	4 A, 600 V
P315–P800, 380–480 V	–	KLK-15	15 A, 600 V
P500–P1M2, 525–690 V	–	KLK-15	15 A, 600 V

Table 10.19 Fan Fuses

Fuse	Size/Type	Bussmann PN	Rating	Alternative fuses
2.5–4.0 A	P450–P800, 380–480 V	LPJ-6 SP or SPI	6 A, 600 V	Any listed Class J Dual Element, Time Delay, 6 A
	P630–P1M2, 525–690 V	LPJ-10 SP or SPI	10 A, 600 V	Any listed Class J Dual Element, Time Delay, 10 A
4.0–6.3 A	P450–P800, 380–480 V	LPJ-10 SP or SPI	10 A, 600 V	Any listed Class J Dual Element, Time Delay, 10 A
	P630–P1M2, 525–690 V	LPJ-15 SP or SPI	15 A, 600 V	Any listed Class J Dual Element, Time Delay, 15 A
6.3–10 A	P450–P800600–1200 hp, 380–480 V	LPJ-15 SP or SPI	15 A, 600 V	Any listed Class J Dual Element, Time Delay, 15 A
	P630–P1M2, 525–690 V	LPJ-20 SP or SPI	20 A, 600 V	Any listed Class J Dual Element, Time Delay, 20 A
10–16 A	P450–P800, 380–480 V	LPJ-25 SP or SPI	25 A, 600 V	Any listed Class J Dual Element, Time Delay, 25 A
	P630–P1M2, 525–690 V	LPJ-20 SP or SPI	20 A, 600 V	Any listed Class J Dual Element, Time Delay, 20 A

Table 10.20 Manual Motor Controller Fuses

Enclosure	Bussmann PN	Rating	Alternative fuses
F	LPJ-30 SP or SPI	30 A, 600 V	Any listed Class J Dual Element, Time Delay, 30 A

Table 10.21 30 A Protected Terminal Fuse

Enclosure	Bussmann PN	Rating	Alternative fuses
F	LPJ-6 SP or SPI	6 A, 600 V	Any listed Class J Dual Element, Time Delay, 6 A

Table 10.22 Control Transformer Fuse

Enclosure	Bussmann PN	Rating	Alternative fuses
F	LP-CC-6	6 A, 600 V	Any listed Class CC, 6 A

Table 10.23 Safety Relay Coil Fuse with Pilz Relay

### 10.5.3 Mains Fuses, F8–F13

The following fuses are suitable for use on a circuit capable of delivering 100000 A<sub>rms</sub> (symmetrical), 240 V, or 480 V, or 600 V depending on the drive voltage rating. With the proper fusing, the drive short-circuit current rating (SCCR) is 100000 A<sub>rms</sub>.

Model	Enclosure size	Rating		Bussmann P/N	Spare Bussmann P/N	Estimated fuse power loss [W]	
		[V] (UL)	[A]			400 V	460 V
P250	F8–F9	700	700	170M4017	176F8591	25	19
P315	F8–F9	700	700	170M4017	176F8591	30	22
P355	F8–F9	700	700	170M4017	176F8591	38	29
P400	F8–F9	700	700	170M4017	176F8591	3500	2800
P450	F10–F11	700	900	170M6013	176F8592	3940	4925
P500	F10–F11	700	900	170M6013	176F8592	2625	2100
P560	F10–F11	700	900	170M6013	176F8592	3940	4925
P630	F10–F11	700	1500	170M6018	176F8592	45	34
P710	F12–F13	700	1500	170M6018	176F9181	60	45
P800	F12–F13	700	1500	170M6018	176F9181	83	63

Table 10.24 Mains Fuses, 380–480 V

Model	Enclosure size	Rating		Bussmann P/N	Spare Bussmann P/N	Estimated fuse power loss [W]	
		[V] (UL)	[A]			600 V	690 V
P355	F8-F9	700	630	170M4016	176F8335	13	10
P400	F8-F9	700	630	170M4016	176F8335	17	13
P500	F8-F9	700	630	170M4016	176F8335	22	16
P560	F8-F9	700	630	170M4016	176F8335	24	18
P630	F10-F11	700	900	170M6013	176F8592	26	20
P710	F10-F11	700	900	170M6013	176F8592	35	27
P800	F10-F11	700	900	170M6013	176F8592	44	33
P900	F12-F13	700	1500	170M6018	176F9181	26	20
P1M0	F12-F13	700	1500	170M6018	176F9181	37	28
P1M2	F12-F13	700	1500	170M6018	176F9181	47	36

Table 10.25 Mains Fuses, 525–690 V

Model	Bussmann PN	Rating	Siba
P450	170M8611	1100 A, 1000 V	20 781 32.1000
P500	170M8611	1100 A, 1000 V	20 781 32.1000
P560	170M6467	1400 A, 700 V	20 681 32.1400
P630	170M6467	1400 A, 700 V	20 681 32.1400
P710	170M8611	1100 A, 1000 V	20 781 32.1000
P800	170M6467	1400 A, 700 V	20 681 32.1400

Table 10.26 Inverter Module DC Link Fuses, 380–480 V

Model	Bussmann PN	Rating	Siba
P630	170M8611	1100 A, 1000 V	20 781 32.1000
P710	170M8611	1100 A, 1000 V	20 781 32.1000
P800	170M8611	1100 A, 1000 V	20 781 32.1000
P900	170M8611	1100 A, 1000 V	20 781 32.1000
P1M0	170M8611	1100 A, 1000 V	20 781 32.1000
P1M2	170M8611	1100 A, 1000 V	20 781 32.1000

Table 10.27 Inverter Module DC Link Fuses, 525–690 V

The 170M fuses from Bussmann shown use the -/80 visual indicator. -TN/80 Type T, -/110, or TN/110 Type T indicator fuses of the same size and amperage can be substituted for external use. To meet UL requirements, use any minimum 480 V UL listed fuse with associated current rating.

Enclosure	Models	Type	Default breaker settings	
			Trip level [A]	Time [s]
F3	380–480 V, Model: P450 525–690 V, Model: P630–P710	Merlin Gerin NPJF36120U31AABSCYP	1200	0.5
F3	380–480 V, Model: P500–P630 525–690 V, Model: P800	Merlin Gerin NRJF36200U31AABSCYP	2000	0.5
F4	380–480 V, Model: P710 525–690 V, Model: P900–P1M2	Merlin Gerin NRJF36200U31AABSCYP	2000	0.5
F4	380–480 V, Model: P800	Merlin Gerin NRJF36250U31AABSCYP	2500	0.5

Table 10.28 Circuit Breakers, F3–F4

## 10.6 Disconnects and Contactors

### 10.6.1 Mains Disconnects, E1–E2 and F3–F4

Enclosure size	Model	Type
<b>380–480 V</b>		
E1–E2	P315–P400	ABB OETL-NF800A
F3	P450	Merlin Gerin NPJF36000S12AAYP
F3	P500–P630	Merlin Gerin NRKF36000S20AAYP
F4	P710–P800	Merlin Gerin NRKF36000S20AAYP
<b>525–690 V</b>		
E1–E2	P355–P560	ABB OETL-NF600A
F3	P630–P710	Merlin Gerin NPJF36000S12AAYP
F3	P800	Merlin Gerin NRKF36000S20AAYP
F4	P900–P1M2	Merlin Gerin NRKF36000S20AAYP

Table 10.29 Mains Disconnects, Enclosures E1–E2 and F3–F4

### 10.6.2 Mains Disconnects, F9/F11/F13

Enclosure size	Model	Type
<b>380–480 V</b>		
F9	P250	ABB OETL-NF600A
F9	P315	ABB OETL-NF600A
F9	P355	ABB OETL-NF600A
F9	P400	ABB OETL-NF600A
F11	P450	ABB OETL-NF800A
F11	P500	ABB OETL-NF800A
F11	P560	ABB OETL-NF800A
F11	P630	ABB OT800U21
F13	P710	Merlin Gerin NPJF36000S12AAYP
F13	P800	Merlin Gerin NPJF36000S12AAYP
<b>525–690 V</b>		
F9	P355	ABB OT400U12-121
F9	P400	ABB OT400U12-121
F9	P500	ABB OT400U12-121
F9	P560	ABB OT400U12-121
F11	P630	ABB OETL-NF600A
F11	P710	ABB OETL-NF600A
F11	P800	ABB OT800U21
F13	P900	ABB OT800U21
F13	P1M0	Merlin Gerin NPJF36000S12AAYP
F13	P1M2	Merlin Gerin NPJF36000S12AAYP

Table 10.30 Mains Disconnects, Enclosures F9/F11/F13



### 10.6.3 Mains Contactors, F3–F4

Enclosure size	Model and voltage	Contactor
F3	P450–P500, 380–480 V P630–P800, 525–690 V	Eaton XTCE650N22A
F3	P560, 380–480 V	Eaton XTCE820N22A
F3	P630, 380–480 V	Eaton XTCEC14P22B
F4	P900, 525–690 V	Eaton XTCE820N22A
F4	P710–P800, 380–480 V P1M2, 525–690 V	Eaton XTCEC14P22B

Table 10.31 Mains Contactors, Enclosures F3–F4

#### **NOTICE**

Customer-supplied 230 V supply is required for mains contactors.

### 10.7 Motor

Any 3-phase asynchronous standard motor can be used with a drive.

Terminal	Function
96	U/T1
97	V/T2
98	W/T3
99	Ground

Table 10.32 Motor Cable Terminals Providing Clockwise Rotation (Factory Default)

The direction of rotation can be changed by switching 2 phases in the motor cable, or by changing the setting of *parameter 4-10 Motor Speed Direction*.

Motor rotation check can be performed using *parameter 1-28 Motor Rotation Check* and following the configuration shown in *Illustration 10.18*.

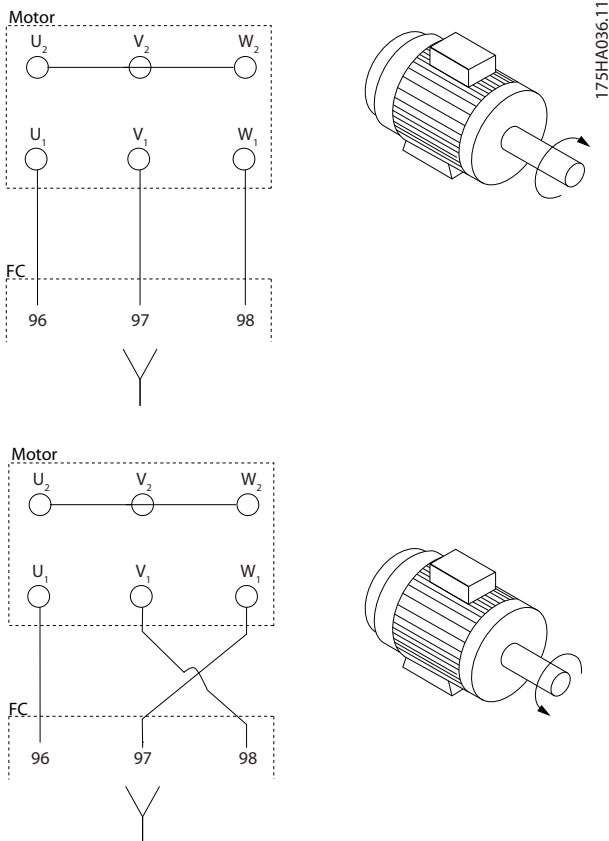

Illustration 10.18 Changing Motor Rotation

**Requirements for enclosures F1/F3**

Each inverter module must have the same number of motor phase cables and they must be in quantities of 2 (for example, 2, 4, 6, or 8). 1 cable is not allowed. The cables are required to be equal length or within 10% between the inverter module terminals and the first common point of a phase. The recommended common point is the motor terminals. For example, if inverter module A used a 100 m (328 ft) cable, then subsequent inverter modules could use a cable between 90–110 m (295–360 ft) in length.

**Requirements for enclosures F2/F4**

Each inverter module must have the same number of motor phase cables and they must be in quantities of 3 (for example, 3, 6, 9, or 12). 1 or 2 cables are not allowed. The cables are required to be equal length or within 10% between the inverter module terminals and the first common point of a phase. The recommended common point is the motor terminals. For example, if inverter module A used a 100 m (328 ft) cable, then subsequent

inverter modules could use a cable between 90–110 m (295–360 ft) in length.

**10.7.1 Motor Thermal Protection**

The electronic thermal relay in the drive has received UL Approval for single motor overload protection, when *parameter 1-90 Motor Thermal Protection* is set for *ETR Trip* and *parameter 1-24 Motor Current* is set to the rated motor current (see the motor nameplate).

For motor thermal protection, it is also possible to use the VLT® PTC Thermistor Card MCB 112 option. This card provides ATEX certification to protect motors in explosion hazardous areas Zone 1/21 and Zone 2/22. When *parameter 1-90 Motor Thermal Protection*, set to [20] *ATEX ETR*, is combined with the use of MCB 112, it is possible to control an Ex-e motor in explosion hazardous areas. Consult the *programming guide* for details on how to set up the drive for safe operation of Ex-e motors.

**10.7.2 Parallel Connection of Motors**

The drive can control several parallel-connected motors. For different configurations of parallel-connected motors, see *Illustration 10.19*.

When using parallel motor connection, observe the following points:

- Run applications with parallel motors in U/F mode (volts per hertz).
- VVC+ mode can be used in some applications.
- Total current consumption of motors must not exceed the rated output current  $I_{INV}$  for the drive.
- Problems can occur at start and at low RPM if motor sizes are widely different because the relatively high ohmic resistance in the stator of a small motor demands a higher voltage at start and at low RPM.
- The electronic thermal relay (ETR) of the drive cannot be used as motor overload protection. Provide further motor overload protection by including thermistors in each motor winding or individual thermal relays.
- When motors are connected in parallel, *parameter 1-02 Flux Motor Feedback Source* cannot be used, and *parameter 1-01 Motor Control Principle* must be set to [0] U/f.

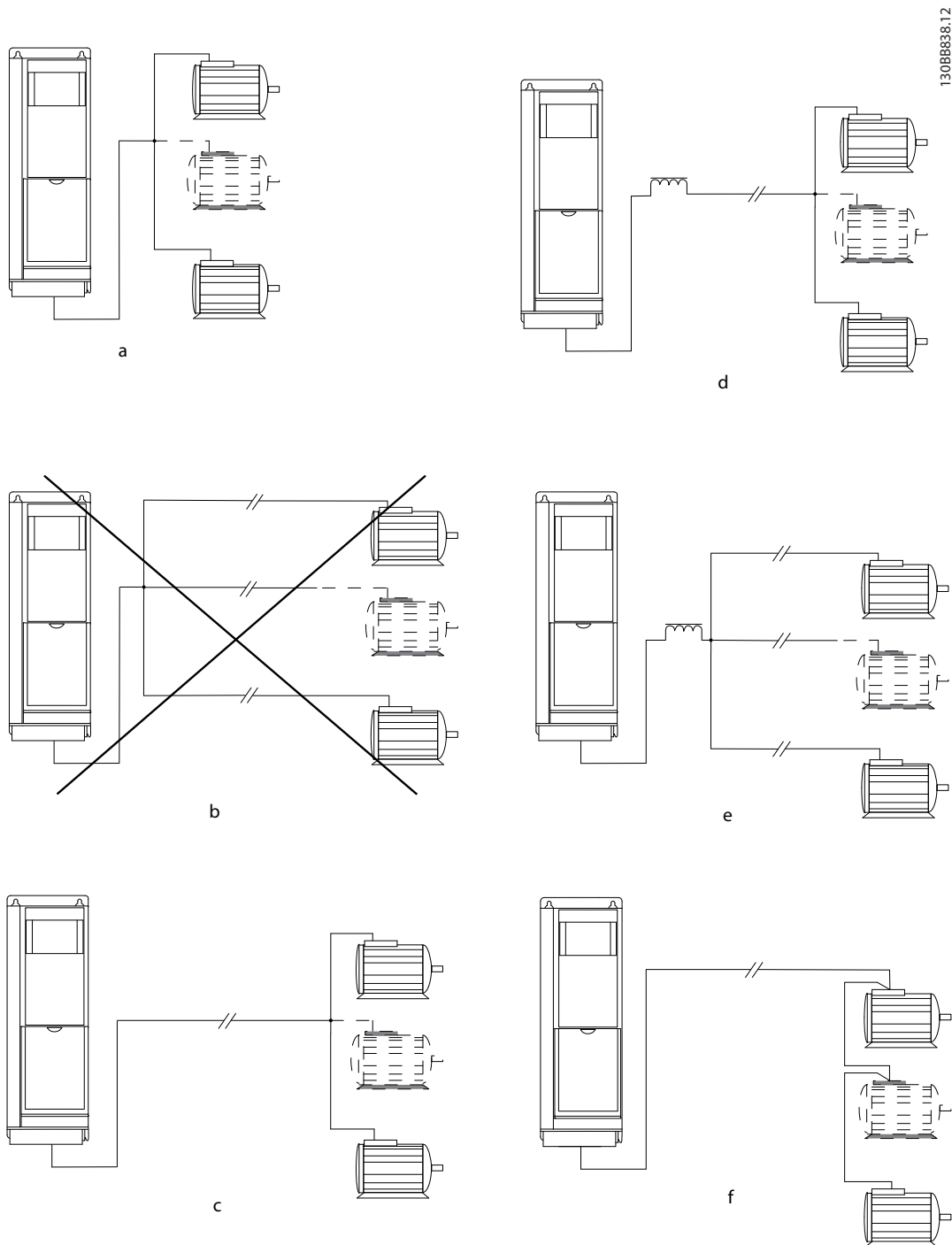

A	Installations with cables connected in a common joint as shown in A and B are only recommended for short cable lengths.
B	Be aware of the maximum motor cable length specified in <i>chapter 7.6 Cable Specifications</i> .
C	The total motor cable length specified in <i>chapter 7.6 Cable Specifications</i> is valid as long as the parallel cables are kept short less than 10 m (32 ft) each.
D	Consider voltage drop across the motor cables.
E	Consider voltage drop across the motor cables.
F	The total motor cable length specified in <i>chapter 7.6 Cable Specifications</i> is valid as long as the parallel cables are kept less than 10 m (32 ft) each.

Illustration 10.19 Different Parallel Connections of Motors

### 10.7.3 Motor Insulation

For motor cable lengths that are less than or equal to the maximum cable length listed in *chapter 7.6 Cable Specifications*, use the motor insulation ratings shown in *Table 10.33*. If a motor has lower insulation rating, Danfoss recommends using a dU/dt or sine-wave filter.

Nominal mains voltage	Motor insulation
$U_N \leq 420$ V	Standard $U_{LL} = 1300$ V
$420 < U_N \leq 500$ V	Reinforced $U_{LL} = 1600$ V
$500 < U_N \leq 600$ V	Reinforced $U_{LL} = 1800$ V
$600 < U_N \leq 690$ V	Reinforced $U_{LL} = 2000$ V

Table 10.33 Motor Insulation Ratings

### 10.7.4 Motor Bearing Currents

To eliminate circulating bearing currents in all motors installed with the drive, install NDE (non-drive end) insulated bearings. To minimize DE (drive end) bearing and shaft currents, ensure proper grounding of the drive, motor, driven machine, and motor to the driven machine.

Standard mitigation strategies:

- Use an insulated bearing.
- Follow proper installation procedures.
  - Ensure that the motor and load motor are aligned.
  - Follow the EMC Installation guideline.
  - Reinforce the PE so the high frequency impedance is lower in the PE than the input power leads.
  - Provide a good high frequency connection between the motor and the drive. Use a shielded cable that has a 360° connection in the motor and the drive.
  - Ensure that the impedance from the drive to building ground is lower than the grounding impedance of the machine. This procedure can be difficult for pumps.
  - Make a direct ground connection between the motor and load motor.
- Lower the IGBT switching frequency.
- Modify the inverter waveform, 60° AVM vs. SFAVM.
- Install a shaft grounding system or use an isolating coupling.
- Apply conductive lubrication.
- Use minimum speed settings if possible.

- Try to ensure that the mains voltage is balanced to ground. This procedure can be difficult for IT, TT, TN-CS, or grounded leg systems.
- Use a dU/dt or sine-wave filter.

## 10.8 Braking

### 10.8.1 Brake Resistor Selection

To handle the higher demands of resistor braking, a brake resistor is necessary. The brake resistor absorbs the energy instead of the drive. For more information, see the *VLT® Brake Resistor MCE 101 Design Guide*.

If the amount of kinetic energy transferred to the resistor in each braking period is not known, the average power can be calculated based on the cycle time and braking time (intermittent duty cycle). The resistor intermittent duty cycle indicates the duty cycle at which the resistor is active. *Illustration 10.20* shows a typical braking cycle.

Motor suppliers often use S5 when stating the allowed load, which is an expression of intermittent duty cycle. The intermittent duty cycle for the resistor is calculated as follows:

$$\text{Duty cycle} = t_b / T$$

$T$  = cycle time in s

$t_b$  is the braking time in s (of the cycle time)

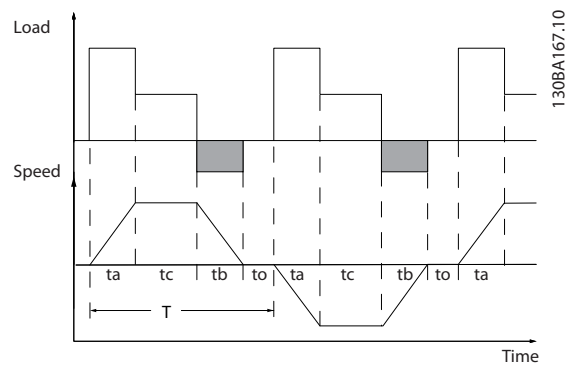

Illustration 10.20 Typical Braking Cycle

380–480 V Model	Cycle time (s)	Braking duty cycle at 100% torque	Braking duty cycle at over torque (150/160%)
P355–P1000	600	40%	10%
525–690 Model	Cycle time (s)	Braking duty cycle at 100% torque	Braking duty cycle at over torque (150/160%)
P560–P630	600	40%	10%
P710–P1M4	600	40%	10%

Table 10.34 Braking at High Overload Torque Level

Danfoss offers brake resistors with duty cycle of 5%, 10%, and 40%. If a 10% duty cycle is applied, the brake resistors are able to absorb brake power for 10% of the cycle time. The remaining 90% of the cycle time is used to dissipate excess heat.

**NOTICE**

Make sure that the resistor is designed to handle the required braking time.

The maximum allowed load on the brake resistor is stated as a peak power at a given intermittent duty cycle. The brake resistance is calculated as shown:

$$R_{br} [\Omega] = \frac{U_{dc}^2}{P_{peak}}$$

where

$$P_{peak} = P_{motor} \times M_{br} [\%] \times \eta_{motor} \times \eta_{VLT} [W]$$

As can be seen, the brake resistance depends on the DC-link voltage (U<sub>dc</sub>).

Size	Brake active	Warning before cutout	Cutout (trip)
380–480 V <sup>1)</sup>	810 V	828 V	855 V
525–690 V	1084 V	1109 V	1130 V

Table 10.35 FC 102/FC 202 Brake Limits

1) Power size dependent

**NOTICE**

Check that the brake resistor can handle a voltage of 410 V, 820 V, 850 V, 975 V, or 1130 V. Danfoss brake resistors are rated for use on all Danfoss drives.

Danfoss recommends the brake resistance R<sub>rec</sub>. This calculation guarantees that the drive is able to brake at the highest brake power (M<sub>br(%)</sub>) of 150%. The formula can be written as:

$$R_{rec} [\Omega] = \frac{U_{dc}^2 \times 100}{P_{motor} \times M_{br(\%)} \times \eta_{VLT} \times \eta_{motor}}$$

η<sub>motor</sub> is typically at 0.90

η<sub>VLT</sub> is typically at 0.98

For 200 V, 480 V, 500 V, and 600 V drives, R<sub>rec</sub> at 160% brake power is written as:

$$200V : R_{rec} = \frac{107780}{P_{motor}} [\Omega]$$

$$500V : R_{rec} = \frac{464923}{P_{motor}} [\Omega]$$

$$600V : R_{rec} = \frac{630137}{P_{motor}} [\Omega]$$

$$690V : R_{rec} = \frac{832664}{P_{motor}} [\Omega]$$

**NOTICE**

The resistor brake circuit resistance selected should not be higher than what Danfoss recommends.

**NOTICE**

If a short circuit occurs in the brake transistor, power dissipation in the brake resistor is prevented only by using a mains switch or contactor to disconnect the mains from the drive, or a contact in the brake circuit. Uninterrupted power dissipation in the brake resistor can cause overheating, damage, or a fire.

**WARNING**

**FIRE HAZARD**

Brake resistors get hot during and after braking. Failure to place the brake resistor in a secure area can result in property damage and/or serious injury.

- Ensure that the brake resistor is placed in a secure environment to avoid fire risk.
- Do not touch the brake resistor during or after braking to avoid serious burns.

10.8.2 Control with Brake Function

A relay/digital output can be used to protect the brake resistor against overloading or overheating by generating a fault in the drive. If the brake IGBT is overloaded or overheated, the relay/digital signal from the brake to the drive turns off the brake IGBT. This relay/digital signal does not protect against a short circuit in the brake IGBT or a ground fault in the brake module or wiring. If a short circuit occurs in the brake IGBT, Danfoss recommends a means to disconnect the brake.

In addition, the brake makes it possible to read out the momentary power and the average power for the latest 120 s. The brake can monitor the power energizing and make sure that it does not exceed the limit selected in

parameter 2-12 Brake Power Limit (kW). Parameter 2-13 Brake Power Monitoring selects what function occurs when the power transmitted to the brake resistor exceeds the limit set in parameter 2-12 Brake Power Limit (kW).

**NOTICE**

Monitoring the brake power is not a safety function; a thermal switch connected to an external contactor is required for that purpose. The brake resistor circuit is not ground leakage protected.

Overvoltage control (OVC) can be selected as an alternative brake function in parameter 2-17 Over-voltage Control. This function is active for all units and ensures that if the DC-link voltage increases, the output frequency also increases to limit the voltage from the DC link, which avoids a trip.

**NOTICE**

OVC cannot be activated when running a PM motor, while parameter 1-10 Motor Construction is set to [1] PM non-salient SPM.

10.9 Residual Current Devices (RCD) and Insulation Resistance Monitor (IRM)

Use RCD relays, multiple protective grounding, or grounding as extra protection, provided they comply with local safety regulations.

If a ground fault appears, a DC current can develop in the faulty current. If RCD relays are used, local regulations must be observed. Relays must be suitable for protection of 3-phase equipment with a bridge rectifier and for a brief discharge on power-up. See chapter 10.10 Leakage Current for more details.

10.10 Leakage Current

Follow national and local codes regarding protective grounding of equipment where leakage current exceeds 3.5 mA.

Drive technology implies high-frequency switching at high power. This high-frequency switching generates a leakage current in the ground connection.

The ground leakage current is made up of several contributions and depends on various system configurations, including:

- RFI filtering.
- Motor cable length.
- Motor cable shielding.
- Drive power.

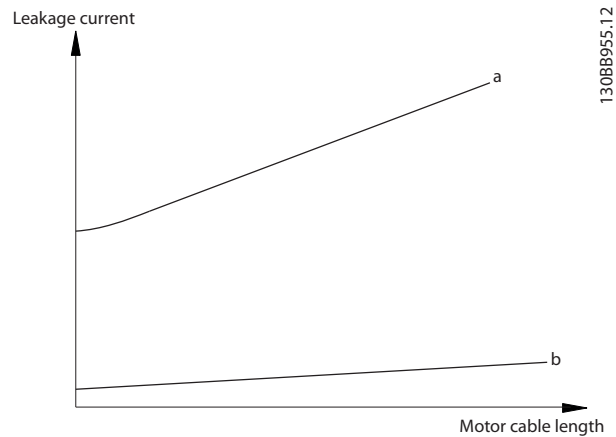

Illustration 10.21 Motor Cable Length and Power Size Influence the Leakage Current. Power Size a > Power Size b.

The leakage current also depends on the line distortion.

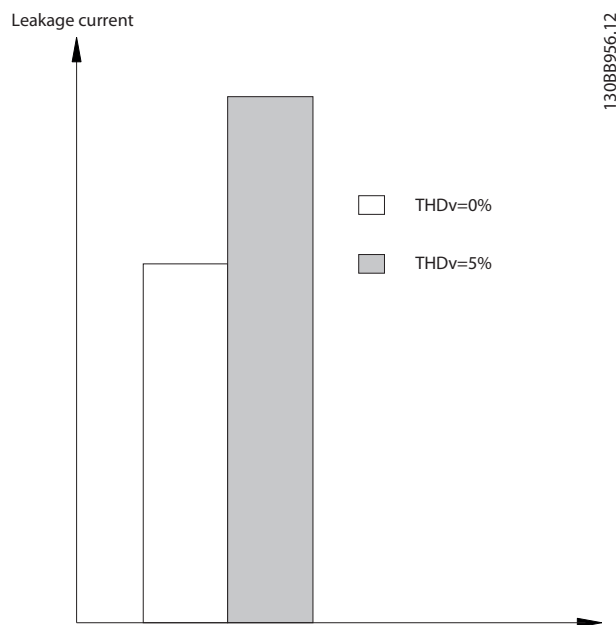

Illustration 10.22 Line Distortion Influences Leakage Current

If the leakage current exceeds 3.5 mA, compliance with EN/IEC61800-5-1 (power drive system product standard) requires special care.

Reinforce grounding with the following protective ground connection requirements:

- Ground wire (terminal 95) of at least 10 mm<sup>2</sup> (8 AWG) cross-section.
- 2 separate ground wires both complying with the dimensioning rules.

See EN/IEC61800-5-1 and EN 50178 for further information.

Using RCDs

Where residual current devices (RCDs), also known as ground leakage circuit breakers, are used, comply with the following:

- Use RCDs of type B only as they can detect AC and DC currents.
- Use RCDs with a delay to prevent faults due to transient ground currents.
- Dimension RCDs according to the system configuration and environmental considerations.

The leakage current includes several frequencies originating from both the mains frequency and the switching frequency. Whether the switching frequency is detected depends on the type of RCD used.

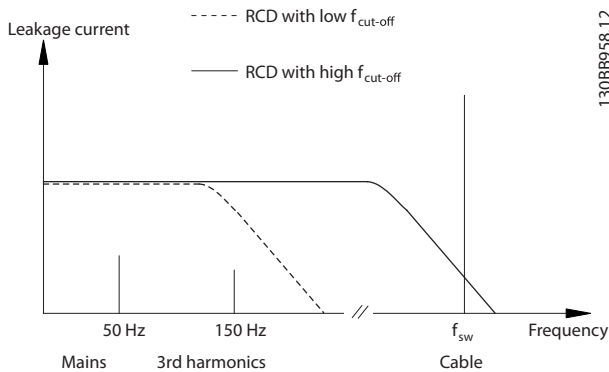

Illustration 10.23 Main Contributions to Leakage Current

The amount of leakage current detected by the RCD depends on the cut-off frequency of the RCD.

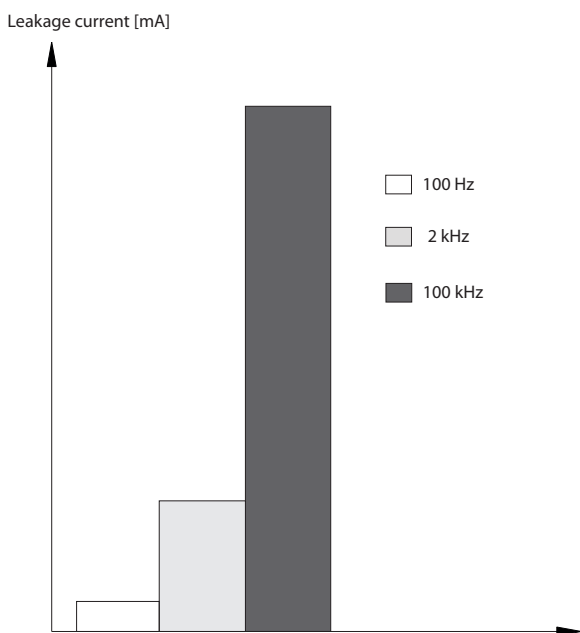

Illustration 10.24 Influence of the RCD Cut-off Frequency on Leakage Current

10.11 IT Grid

Mains supply isolated from ground

If the drive is supplied from an isolated mains source (IT mains, floating delta, or grounded delta) or TT/TN-S mains with grounded leg, the RFI switch is recommended to be turned off via *parameter 14-50 RFI Filter* on the drive and *parameter 14-50 RFI Filter* on the filter. For more detail, see IEC 364-3. In the off position, the filter capacitors between the chassis and the DC link are cut off to avoid damage to the DC link and to reduce the ground capacity currents, according to IEC 61800-3.

If optimum EMC performance is needed, or parallel motors are connected, or the motor cable length is above 25 m (82 ft), Danfoss recommends setting *parameter 14-50 RFI Filter* to [ON]. Refer also to the *Application Note, VLT on IT Mains*. It is important to use isolation monitors that are rated for use together with power electronics (IEC 61557-8).

Danfoss does not recommend using an output contactor for 525–690 V drives connected to an IT mains network.

10.12 Efficiency

Efficiency of the drive ( $\eta_{VLT}$ )

The load on the drive has little effect on its efficiency. In general, the efficiency is the same at the rated motor frequency  $f_{M,N}$ , whether the motor supplies 100% of the rated shaft torque or only 75%, in case of part loads.

The efficiency of the drive does not change even if other U/f characteristics are selected. However, the U/f characteristics influence the efficiency of the motor.

The efficiency declines slightly when the switching frequency is set to a value of above 5 kHz. The efficiency is slightly reduced when the mains voltage is 480 V, or if the motor cable is longer than 30 m (98 ft).

Drive efficiency calculation

Calculate the efficiency of the drive at different speeds and loads based on *Illustration 10.25*. The factor in this graph must be multiplied by the specific efficiency factor listed in the specification tables in *chapter 7.1 Electrical Data, 380–480 V* and *chapter 7.2 Electrical Data, 525–690 V*.

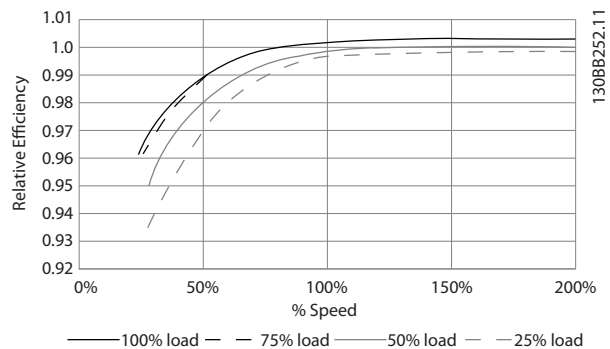

Illustration 10.25 Typical Efficiency Curves

Example: Assume a 160 kW, 380–480 V AC drive at 25% load at 50% speed. *Illustration 10.25* shows 0.97 - rated efficiency for a 160 kW drive is 0.98. The actual efficiency is then:  $0.97 \times 0.98 = 0.95$ .

#### Efficiency of the motor ( $\eta_{\text{MOTOR}}$ )

The efficiency of a motor connected to the drive depends on magnetizing level. In general, the efficiency is as good as with mains operation. The efficiency of the motor depends on the type of motor.

In the range of 75–100% of the rated torque, the efficiency of the motor is practically constant, both when the drive controls it and when it runs directly on the mains.

In small motors, the influence from the U/f characteristic on efficiency is marginal. However, in motors from 11 kW (15 hp) and up, the advantages are significant.

Typically the switching frequency does not affect the efficiency of small motors. Motors from 11 kW (15 hp) and up have their efficiency improved (1–2%) because the shape of the motor current sine-wave is almost perfect at high switching frequency.

#### Efficiency of the system ( $\eta_{\text{SYSTEM}}$ )

To calculate system efficiency, the efficiency of the drive ( $\eta_{\text{VLT}}$ ) is multiplied by the efficiency of the motor ( $\eta_{\text{MOTOR}}$ ):  
 $\eta_{\text{SYSTEM}} = \eta_{\text{VLT}} \times \eta_{\text{MOTOR}}$

### 10.13 Acoustic Noise

The acoustic noise from the drive comes from 3 sources:

- DC link coils.
- Internal fans.
- RFI filter choke.

*Table 10.36* lists the typical acoustic noise values measured at a distance of 1 m (9 ft) from the unit.

Enclosure size	dBA at full fan speed
E1–E2 <sup>1)</sup>	74
E1–E2 <sup>2)</sup>	83
F1–F4 and F8–F13	80

**Table 10.36 Acoustic Noise**

1) P450–P500, 525–690 V only.

2) All other enclosure E models.

Test results performed according to ISO 3744 for audible noise magnitude in a controlled environment. Noise tone

has been quantified for engineering data record of hardware performance per ISO 1996-2 Annex D.

### 10.14 dU/dt Conditions

#### NOTICE

To avoid the premature aging of motors that are not designed to be used with drives, such as those motors without phase insulation paper or other insulation reinforcement, Danfoss strongly recommends a dU/dt filter or a sine-wave filter fitted on the output of the drive. For further information about dU/dt and sine-wave filters, see the *Output Filters Design Guide*.

When a transistor in the inverter bridge switches, the voltage across the motor increases by a dU/dt ratio depending on:

- The motor cable (type, cross-section, length shielded or unshielded).
- Inductance.

The natural induction causes an overshoot  $U_{\text{PEAK}}$  in the motor voltage before it stabilizes itself at a level depending on the voltage in the DC link. The rise time and the peak voltage  $U_{\text{PEAK}}$  affect the service life of the motor. In particular, motors without phase coil insulation are affected if the peak voltage is too high. Motor cable length affects the rise time and peak voltage. For example, if the motor cable is short (a few meters), the rise time and peak voltage are lower. If the motor cable is long (100 m (328 ft)), the rise time and peak voltage are higher.

The switching of the IGBTs causes the peak voltage on the motor terminals. The drive complies with the demands of IEC 60034-25 regarding motors designed to be controlled by drives. The drive also complies with IEC 60034-17 regarding normal motors controlled by drives.

#### High-power range

The power sizes in *Table 10.37* and *Table 10.38* at the appropriate mains voltages comply with the requirements of IEC 60034-17 regarding normal motors controlled by drives, IEC 60034-25 regarding motors designed to be controlled by drives, and NEMA MG 1-1998 Part 31.4.4.2 for inverter-fed motors. The power sizes in *Table 10.37* and *Table 10.38* do not comply with NEMA MG 1-1998 Part 30.2.2.8 for general-purpose motors.



**380–480 V**

Model	Cable length [m (ft)]	Mains voltage [V]	Rise time [μs]	Peak voltage [V]	dU/dt [V/μs]
P315–P1M0 (380–480 V)	30 (98.5)	500	0.71	1165	1389
	30 (98.5)	500 <sup>1)</sup>	0.80	906	904
	30 (98.5)	400	0.61	942	1233
	30 (98.5)	400 <sup>1)</sup>	0.82	760	743

**Table 10.37 dU/dt Enclosures E1–E2 and F1–F13, 380–480 V**

<sup>1)</sup> With Danfoss dU/dt filter

**525–690 V**

Model	Cable length [m (ft)]	Mains voltage [V]	Rise time [μs]	Peak voltage [V]	dU/dt [V/μs]
P450–P1M4 (525–690 V)	30 (98.5)	690	0.57	1611	2261
	30 (98.5)	575	0.25	–	2510
	30 (98.5)	690 <sup>1)</sup>	1.13	1629	1150

**Table 10.38 dU/dt Enclosures E1–E2 and F1–F13, 525–690 V**

<sup>1)</sup> With Danfoss dU/dt filter.

## 10.15 Electromagnetic Compatibility (EMC) Overview

Electrical devices both generate interference and are affected by interference from other generated sources. The electromagnetic compatibility (EMC) of these effects depends on the power and the harmonic characteristics of the devices.

Uncontrolled interaction between electrical devices in a system can degrade compatibility and impair reliable operation. Interference takes the form of the following:

- Electrostatic discharges
- Rapid voltage fluctuations
- High-frequency interference

Electrical interference is most commonly found at frequencies in the range 150 kHz to 30 MHz. Airborne interference from the drive system in the range 30 MHz to 1 GHz is generated from the inverter, motor cable, and the motor.

Capacitive currents in the motor cable, coupled with a high dU/dt from the motor voltage, generate leakage currents. See *Illustration 10.26*. Shielded motor cables have higher capacitance between the phase wires and the shield, and again between the shield and ground. This added cable capacitance, along with other parasitic capacitance and motor inductance, changes the electromagnetic emission signature produced by the unit. The change in electromagnetic emission signature occurs mainly in emissions less than 5 MHz. Most of the leakage current (I1) is carried back to the unit through the PE (I3), leaving only a small electromagnetic field (I4) from the shielded motor cable. The shield reduces the radiated interference but increases the low-frequency interference on the mains.

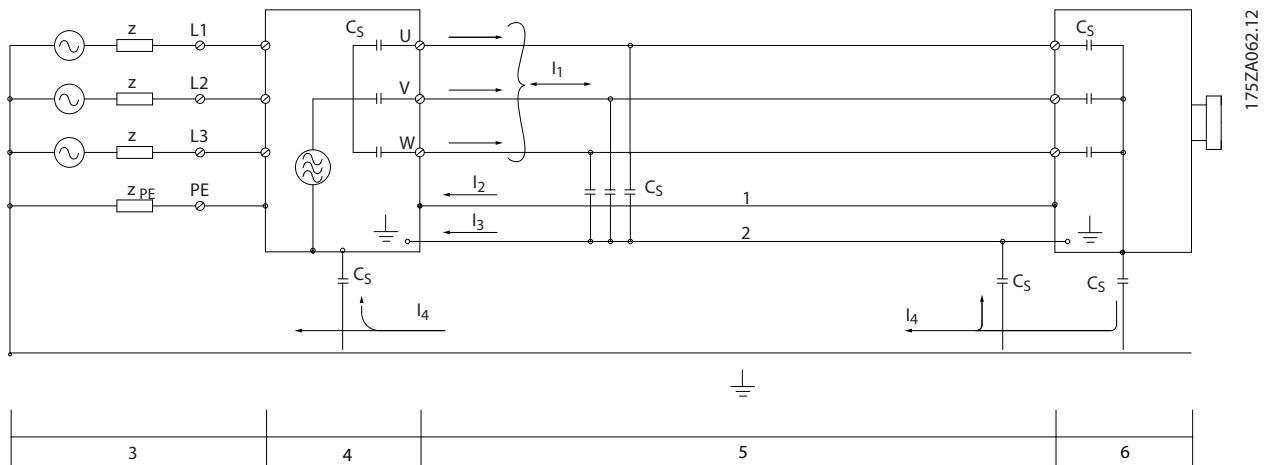

1	Ground wire	Cs	Possible shunt parasitic capacitance paths (varies with different installations)
2	Shield	I1	Common-mode leakage current
3	AC mains supply	I2	Shielded motor cable
4	Drive	I3	Safety ground (4 <sup>th</sup> conductor in motor cables)
5	Shielded motor cable	I4	Unintended common-mode current
6	Motor	-	-

Illustration 10.26 Electric Model Showing Possible Leakage Currents

10

10.15.1 EMC Test Results

The following test results have been obtained using a drive (with options if relevant), a shielded control cable, a control box with potentiometer, a motor, and motor shielded cable.

RFI filter type		Conducted emission			Radiated emission		
Standards and requirements		Class B Housing, trades, and light industries	Class A group 1 Industrial environme nt	Class A group 2 Industrial environment	Class B Housing, trades, and light industries	Class A group 1 Industrial environment	Class A group 2 Industrial environment
	EN 55011						
	EN/IEC 61800-3	Category C1 First environment Home and office	Category C2 First environme nt Home and office	Category C3 Second environment Industrial	Category C1 First environment Home and office	Category C2 First environment Home and office	Category C3 First environment Home and office
<b>H2</b>							
FC 102	355–1000 kW 380–480 V	No	No	150 m (492 ft)	No	No	Yes
	450–1400 kW 525–690 V	No	No	150 m (492 ft)	No	No	Yes
<b>H4</b>							
FC 102	355–1000 kW 380–480 V	No	150 m (492 ft)	150 m (492 ft)	No	Yes	Yes
	450–1400 kW 525–690 V	-	-	-	-	-	-

Table 10.39 EMC Test Results (Emission and Immunity)

## 10.15.2 Emission Requirements

According to the EMC product standard for adjustable speed drives EN/IEC 61800-3:2004, the EMC requirements depend on the environment in which the drive is installed. These environments along with the mains voltage supply requirements are defined in *Table 10.40*.

The drives comply with EMC requirements described in IEC/EN 61800-3 (2004)+AM1 (2011), category C3, for equipment having greater than 100 A per-phase current draw, installed in the second environment. Compliance testing is performed with a 150 m (492 ft) shielded motor cable.

Category (EN 61800-3)	Definition	Conducted emission (EN 55011)
C1	First environment (home and office) with a supply voltage less than 1000 V.	Class B
C2	First environment (home and office) with a supply voltage less than 1000 V, which is not plug-in or movable and where a professional is intended to be used to install or commission the system.	Class A Group 1
C3	Second environment (industrial) with a supply voltage lower than 1000 V.	Class A Group 2
C4	Second environment with the following: <ul style="list-style-type: none"> <li>• Supply voltage equal to or above 1000 V.</li> <li>• Rated current equal to or above 400 A.</li> <li>• Intended for use in complex systems.</li> </ul>	No limit line. An EMC plan must be made.

**Table 10.40 Emission Requirements**

When the generic emission standards are used, the drives are required to comply with *Table 10.41*.

Environment	Generic standard	Conducted emission requirement according to EN 55011 limits
First environment (home and office)	EN/IEC 61000-6-3 Emission standard for residential, commercial, and light industrial environments.	Class B
Second environment (industrial environment)	EN/IEC 61000-6-4 Emission standard for industrial environments.	Class A Group 1

**Table 10.41 Generic Emission Standard Limits**

## 10.15.3 Immunity Requirements

The immunity requirements for drives depend on the installation environment. The requirements for the industrial environment are higher than the requirements for the home and office environment. All Danfoss drives comply with the requirements for both the industrial and the home/office environment.

To document immunity against burst transient, the following immunity tests have been performed on a drive (with options if relevant), a shielded control cable, and a control box with potentiometer, motor cable, and motor. The tests were performed in accordance with the following basic standards. For more details, see *Table 10.42*.

- **EN 61000-4-2 (IEC 61000-4-2):** Electrostatic discharges (ESD): Simulation of electrostatic discharges from human beings.
- **EN 61000-4-3 (IEC 61000-4-3):** Incoming electromagnetic field radiation, amplitude modulated simulation of the effects of radar, radio communication equipment, and mobile communications equipment.
- **EN 61000-4-4 (IEC 61000-4-4):** Burst transients: Simulation of interference brought about by switching a contactor, relay, or similar devices.

- EN 61000-4-5 (IEC 61000-4-5): Surge transients: Simulation of transients brought about by lightning strikes near installations.
- EN 61000-4-6 (IEC 61000-4-6): RF common mode: Simulation of the effect from radio-transmission equipment joined by connection cables.

Basic standard	Burst IEC 61000-4-4	Surge IEC 61000-4-5	ESD IEC 61000-4-2	Radiated electro-magnetic field IEC 61000-4-3	RF common mode voltage IEC 61000-4-6
Acceptance criterion	B	B	B	A	A
Line	4 kV CM	2 kV/2 Ω DM 4 kV/12 Ω CM	–	–	10 V <sub>RMS</sub>
Motor	4 kV CM	4 kV/2 Ω <sup>1)</sup>	–	–	10 V <sub>RMS</sub>
Brake	4 kV CM	4 kV/2 Ω <sup>1)</sup>	–	–	10 V <sub>RMS</sub>
Load sharing	4 kV CM	4 kV/2 Ω <sup>1)</sup>	–	–	10 V <sub>RMS</sub>
Control wires	2 kV CM	2 kV/2 Ω <sup>1)</sup>	–	–	10 V <sub>RMS</sub>
Standard bus	2 kV CM	2 kV/2 Ω <sup>1)</sup>	–	–	10 V <sub>RMS</sub>
Relay wires	2 kV CM	2 kV/2 Ω <sup>1)</sup>	–	–	10 V <sub>RMS</sub>
Application/fieldbus options	2 kV CM	2 kV/2 Ω <sup>1)</sup>	–	–	10 V <sub>RMS</sub>
LCP cable	2 kV CM	2 kV/2 Ω <sup>1)</sup>	–	–	10 V <sub>RMS</sub>
External 24 V DC	2 V CM	0.5 kV/2 Ω DM 1 kV/12 Ω CM	–	–	10 V <sub>RMS</sub>
Enclosure	–	–	8 kV AD 6 kV CD	10 V/m	–

Table 10.42 EMC Immunity Form, Voltage Range: 380–480/500 V, 525–600 V, 525–690 V

1) Injection on cable shield.

AD: air discharge; CD: contact discharge; CM: common mode; DM: differential mode.

10

## 10.15.4 EMC Compatibility

### **NOTICE**

#### OPERATOR RESPONSIBILITY

According to the EN 61800–3 standard for variable-speed drive systems, the operator is responsible for ensuring EMC compliance. Manufacturers can offer solutions for operation conforming to the standard. Operators are responsible for applying these solutions, and for paying the associated costs.

There are 2 options for ensuring electromagnetic compatibility.

- Eliminate or minimize interference at the source of emitted interference.
- Increase the immunity to interference in devices affected by its reception.

#### RFI filters

The goal is to obtain systems that operate stably without radio frequency interference between components. To achieve a high level of immunity, use drives with high-quality RFI filters.

### **NOTICE**

#### RADIO INTERFERENCE

In a residential environment, this product can cause radio interference, in which case supplementary mitigation measures may be required.

#### PELV and galvanic isolation compliance

All E1h–E4h drives control and relay terminals comply with PELV (excluding grounded Delta leg above 400 V).

Galvanic (ensured) isolation is obtained by fulfilling requirements for higher isolation and by providing the relevant creepage/clearance distances. These requirements are described in the EN 61800–5–1 standard.

Electrical isolation is provided as shown (see *Illustration 10.27*). The components described comply with both PELV and the galvanic isolation requirements.

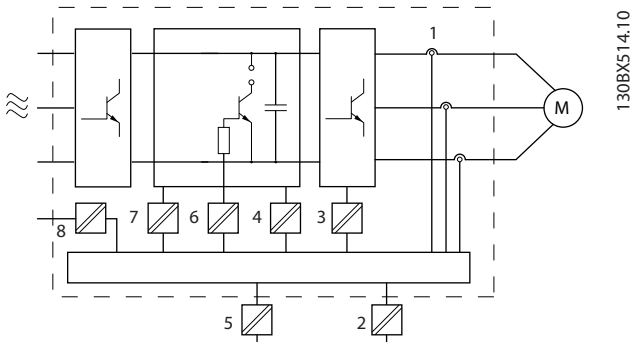

1	Current transducers
2	Galvanic isolation for the RS485 standard bus interface
3	Gate drive for the IGBTs
4	Supply (SMPS) including signal isolation of V DC, indicating the intermediate current voltage
5	Galvanic isolation for the 24 V back-up option
6	Opto-coupler, brake module (optional)
7	Internal inrush, RFI, and temperature measurement circuits
8	Customer relays

Illustration 10.27 Galvanic Isolation

### 10.16 EMC-compliant Installation

To obtain an EMC-compliant installation, follow the instructions provided in the *operating guide*. For an example of proper EMC installation, see *Illustration 10.28*.

#### **NOTICE**

##### TWISTED SHIELD ENDS (PIGTAILS)

Twisted shield ends increase the shield impedance at higher frequencies, which reduces the shield effect and increases the leakage current. Avoid twisted shield ends by using integrated shield clamps.

- For use with relays, control cables, a signal interface, fieldbus, or brake, connect the shield to the enclosure at both ends. If the ground path has high impedance, is noisy, or is carrying current, break the shield connection on 1 end to avoid ground current loops.
- Convey the currents back to the unit using a metal mounting plate. Ensure good electrical contact from the mounting plate through the mounting screws to the drive chassis.
- Use shielded cables for motor output cables. An alternative is unshielded motor cables within metal conduit.

#### **NOTICE**

##### SHIELDED CABLES

If shielded cables or metal conduits are not used, the unit and the installation do not meet regulatory limits on radio frequency (RF) emission levels.

- Ensure that motor and brake cables are as short as possible to reduce the interference level from the entire system.
- Avoid placing cables with a sensitive signal level alongside motor and brake cables.
- For communication and command/control lines, follow the particular communication protocol standards. For example, USB must use shielded cables, but RS485/ethernet can use shielded UTP or unshielded UTP cables.
- Ensure that all control terminal connections are PELV.

#### **NOTICE**

##### EMC INTERFERENCE

Use shielded cables for motor and control wiring. Make sure to separate mains input, motor, and control cables from one another. Failure to isolate these cables can result in unintended behavior or reduced performance. Minimum 200 mm (7.9 in) clearance between mains input, motor, and control cables are required.

#### **NOTICE**

##### INSTALLATION AT HIGH ALTITUDE

There is a risk for overvoltage. Isolation between components and critical parts could be insufficient, and not comply with PELV requirements. Reduce the risk for overvoltage by using external protective devices or galvanic isolation.

For installations above 2000 m (6500 ft) altitude, contact Danfoss regarding PELV compliance.

#### **NOTICE**

##### PELV COMPLIANCE

Prevent electric shock by using protective extra low voltage (PELV) electrical supply and complying with local and national PELV regulations.

130BF228.10

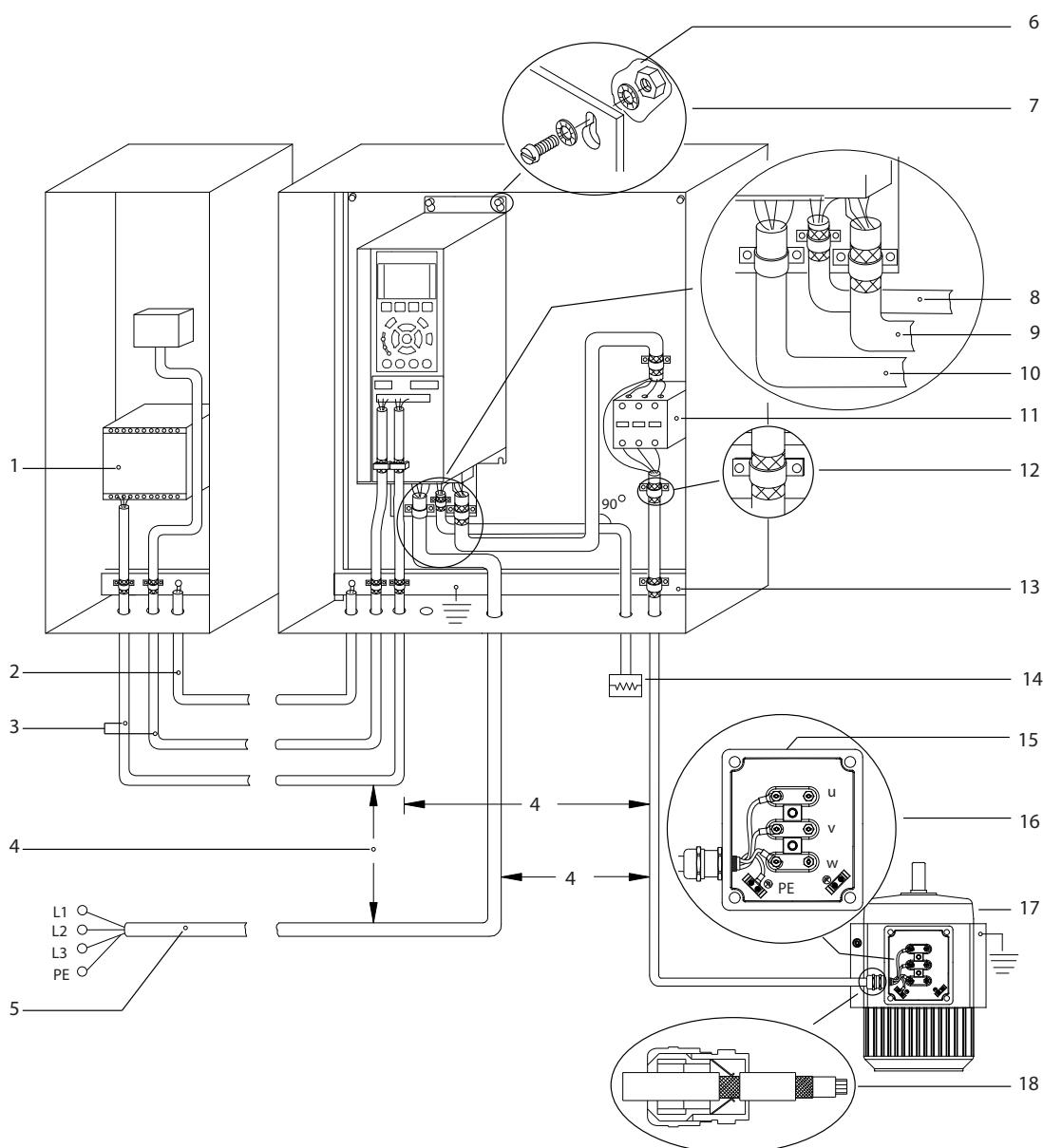

10

1	PLC	10	Mains cable (unshielded)
2	Minimum 16 mm <sup>2</sup> (6 AWG) equalizing cable	11	Output contactor
3	Control cables	12	Cable insulation stripped
4	Minimum 200 mm (7.9 in) between control cables, motor cables, and mains cables.	13	Common ground busbar. Follow local and national requirements for cabinet grounding.
5	Mains supply	14	Brake resistor
6	Bare (unpainted) surface	15	Metal box
7	Star washers	16	Connection to motor
8	Brake cable (shielded)	17	Motor
9	Motor cable (shielded)	18	EMC cable gland

Illustration 10.28 Example of Proper EMC Installation

### 10.17 Harmonics Overview

Non-linear loads such as found with drives do not draw current uniformly from the power line. This non-sinusoidal current has components which are multiples of the basic current frequency. These components are referred to as harmonics. It is important to control the total harmonic distortion on the mains supply. Although the harmonic currents do not directly affect electrical energy consumption, they generate heat in wiring and transformers that can affect other devices on the same power line.

#### 10.17.1 Harmonic Analysis

Since harmonics increase heat losses, it is important to design systems with harmonics in mind to prevent overloading the transformer, inductors, and wiring. When necessary, perform an analysis of the system harmonics to determine equipment effects.

A non-sinusoidal current is transformed with a Fourier series analysis into sine-wave currents at different frequencies, that is, different harmonic currents  $I_n$  with 50 Hz or 60 Hz as the basic frequency.

Abbreviation	Description
$f_1$	Basic frequency (50 Hz or 60 Hz)
$I_1$	Current at the basic frequency
$U_1$	Voltage at the basic frequency
$I_n$	Current at the $n^{\text{th}}$ harmonic frequency
$U_n$	Voltage at the $n^{\text{th}}$ harmonic frequency
$n$	Harmonic order

Table 10.43 Harmonics-related Abbreviations

	Basic current ( $I_1$ )		Harmonic current ( $I_n$ )		
	$I_1$	$I_5$	$I_7$	$I_{11}$	
Current	$I_1$	$I_5$	$I_7$	$I_{11}$	
Frequency	50 Hz	250 Hz	350 Hz	550 Hz	

Table 10.44 Basic Currents and Harmonic Currents

Current	Harmonic current				
	$I_{RMS}$	$I_1$	$I_5$	$I_7$	$I_{11-49}$
Input current	1.0	0.9	0.5	0.2	<0.1

Table 10.45 Harmonic Currents vs. RMS Input Current

The voltage distortion on the mains supply voltage depends on the size of the harmonic currents multiplied by the mains impedance for the frequency in question. The total voltage distortion (THDi) is calculated based on the individual voltage harmonics using this formula:

$$THDi = \frac{\sqrt{U_{25}^2 + U_{27}^2 + \dots + U_{2n}^2}}{U}$$

#### 10.17.2 Effect of Harmonics in a Power Distribution System

In *Illustration 10.29*, a transformer is connected on the primary side to a point of common coupling PCC1, on the medium voltage supply. The transformer has an impedance  $Z_{xfr}$  and feeds several loads. The point of common coupling where all loads are connected is PCC2. Each load connects through cables that have an impedance  $Z_1, Z_2, Z_3$ .

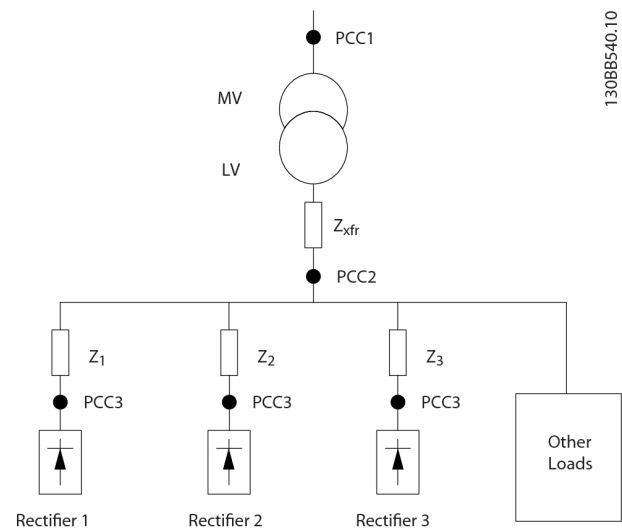

PCC	Point of common coupling
MV	Medium voltage
LV	Low voltage
$Z_{xfr}$	Transformer impedance
$Z_{\#}$	Modeling resistance and inductance in the wiring

Illustration 10.29 Small Distribution System

Harmonic currents drawn by non-linear loads cause distortion of the voltage because of the voltage drop on the impedances of the distribution system. Higher impedances result in higher levels of voltage distortion.

Current distortion relates to apparatus performance and it relates to the individual load. Voltage distortion relates to system performance. It is not possible to determine the voltage distortion in the PCC knowing only the harmonic performance of the load. To predict the distortion in the PCC, the configuration of the distribution system and relevant impedances must be known.

A commonly used term for describing the impedance of a grid is the short circuit ratio  $R_{sce}$ , where  $R_{sce}$  is defined as the ratio between the short circuit apparent power of the supply at the PCC ( $S_{sc}$ ) and the rated apparent power of the load.

$$(S_{equ}).R_{sce} = \frac{S_{sc}}{S_{equ}}$$

$$\text{where } S_{sc} = \frac{U^2}{Z_{supply}} \text{ and } S_{equ} = U \times I_{equ}$$

#### Negative effects of harmonics

- Harmonic currents contribute to system losses (in cabling and transformer).
- Harmonic voltage distortion causes disturbance to other loads and increases losses in other loads.

### 10.17.3 IEC Harmonic Standards

In most of Europe, the basis for the objective assessment of the quality of mains power is the Electromagnetic Compatibility of Devices Act (EMVG). Compliance with these regulations ensures that all devices and networks connected to electrical distribution systems fulfill their intended purpose without generating problems.

Standard	Definition
EN 61000-2-2, EN 61000-2-4, EN 50160	Define the mains voltage limits required for public and industrial power grids.
EN 61000-3-2, 61000-3-12	Regulate mains interference generated by connected devices in lower current products.
EN 50178	Monitors electronic equipment for use in power installations.

Table 10.46 EN Design Standards for Mains Power Quality

There are 2 European standards that address harmonics in the frequency range from 0 Hz to 9 kHz:

10

#### EN 61000–2–2 (Compatibility Levels for Low-Frequency Conducted Disturbances and Signaling in Public Low-Voltage Power Supply Systems)

The EN 61000–2–2 standard states the requirements for compatibility levels for PCC (point of common coupling) of low-voltage AC systems on a public supply network. Limits are specified only for harmonic voltage and total harmonic distortion of the voltage. EN 61000–2–2 does not define limits for harmonic currents. In situations where the total harmonic distortion THD(V)=8%, PCC limits are identical to those limits specified in the EN 61000–2–4 Class 2.

#### EN 61000–2–4 (Compatibility Levels for Low-Frequency Conducted Disturbances and Signaling in Industrial Plants)

The EN 61000–2–4 standard states the requirements for compatibility levels in industrial and private networks. The standard further defines the following 3 classes of electromagnetic environments:

- Class 1 relates to compatibility levels that are less than the public supply network, which affects equipment sensitive to disturbances (lab equipment, some automation equipment, and certain protection devices).
- Class 2 relates to compatibility levels that are equal to the public supply network. The class applies to PCCs on the public supply network and to IPCs (internal points of coupling) on industrial or other private supply networks. Any equipment designed for operation on a public supply network is allowed in this class.
- Class 3 relates to compatibility levels greater than the public supply network. This class applies only to IPCs in industrial environments. Use this class where the following equipment is found:
  - Large drives.
  - Welding machines.
  - Large motors starting frequently.
  - Loads that change quickly.

Typically, a class cannot be defined ahead of time without considering the intended equipment and processes to be used in the environment. VLT® high-power drives observe the limits of Class 3 under typical supply system conditions ( $R_{sc} > 10$  or  $v_{k, Line} < 10\%$ ).



Harmonic order (h)	Class 1 (V <sub>h</sub> %)	Class 2 (V <sub>h</sub> %)	Class 3 (V <sub>h</sub> %)
5	3	6	8
7	3	5	7
11	3	3.5	5
13	3	3	4.5
17	2	2	4
17 < h ≤ 49	2.27 x (17/h) – 0.27	2.27 x (17/h) – 0.27	4.5 x (17/h) – 0.5

Table 10.47 Compatibility Levels for Harmonics

	Class 1	Class 2	Class 3
THDv	5%	8%	10%

Table 10.48 Compatibility Levels for the Total Harmonic Voltage Distortion THDv

### 10.17.4 Harmonic Compliance

Danfoss drives comply with the following standards:

- IEC61000-2-4
- IEC61000-3-4
- G5/4

### 10.17.5 Harmonic Mitigation

In cases where extra harmonic suppression is required, Danfoss offers the following mitigation equipment:

- VLT<sup>®</sup> 12-pulse drives
- VLT<sup>®</sup> Low harmonic drives
- VLT<sup>®</sup> Advanced harmonic filters
- VLT<sup>®</sup> Advanced active filters

Selecting the right solution depends on several factors:

- The grid (background distortion, mains unbalance, resonance, and type of supply (transformer/generator).
- Application (load profile, number of loads, and load size).
- Local/national requirements/regulations (such as IEEE 519, IEC, and G5/4).
- Total cost of ownership (initial cost, efficiency, and maintenance).

### 10.17.6 Harmonic Calculation

Use the free Danfoss MCT 31 calculation software to determine the degree of voltage pollution on the grid and needed precaution. The VLT<sup>®</sup> *Harmonic Calculation MCT 31* is available at [www.danfoss.com](http://www.danfoss.com).

# 11 Basic Operating Principles of a Drive

This chapter provides an overview of the primary assemblies and circuitry of a Danfoss drive. It describes the internal electrical and signal processing functions. A description of the internal control structure is also included.

## 11.1 Description of Operation

A drive is an electronic controller that supplies a regulated amount of AC power to a 3-phase inductive motor. By supplying variable frequency and voltage to the motor, the drive varies the motor speed or maintains a constant speed as the load on the motor changes. Also, the drive can stop and start a motor without the mechanical stress associated with a line start.

In its basic form, the drive can be divided into the following 4 main areas:

### Rectifier

The rectifier consists of SCRs or diodes that convert 3-phase AC voltage to pulsating DC voltage.

### DC link (DC bus)

The DC link consists of inductors and capacitor banks that stabilize the pulsating DC voltage.

### Inverter

The inverter uses IGBTs to convert the DC voltage to variable voltage and variable frequency AC.

### Control

The control area consists of software that runs the hardware to produce the variable voltage that controls and regulates the AC motor.

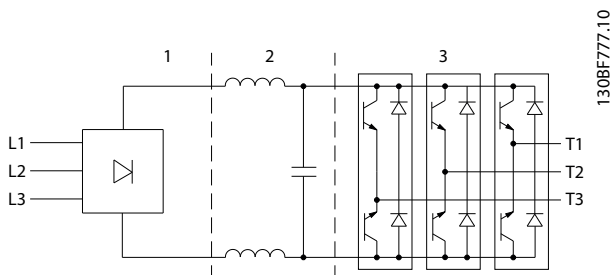

1	Rectifier (SCR/diodes)
2	DC link (DC bus)
3	Inverter (IGBTs)

Illustration 11.1 Internal Processing

## 11.2 Drive Controls

The following processes are used to control and regulate the motor:

- User input/reference.
- Feedback handling.
- User-defined control structure.
  - Open loop/closed-loop mode.
  - Motor control (speed, torque, or process).
- Control algorithms (VVC<sup>+</sup>, flux sensorless, flux with motor feedback, and internal current control VVC<sup>+</sup>).

### 11.2.1 User Inputs/References

The drive uses an input source (also called reference) to control and regulate the motor. The drive receives this input either

- Manually via the LCP. This method is referred to as local (Hand On).
- Remotely via analog/digital inputs and various serial interfaces (RS485, USB, or an optional fieldbus). This method is referred to as remote (Auto On) and is the default input setting.

#### Active reference

The term active reference refers to the active input source. The active reference is configured in *parameter 3-13 Reference Site*. See *Illustration 11.2* and *Table 11.1*.

For more information, see the *programming guide*.

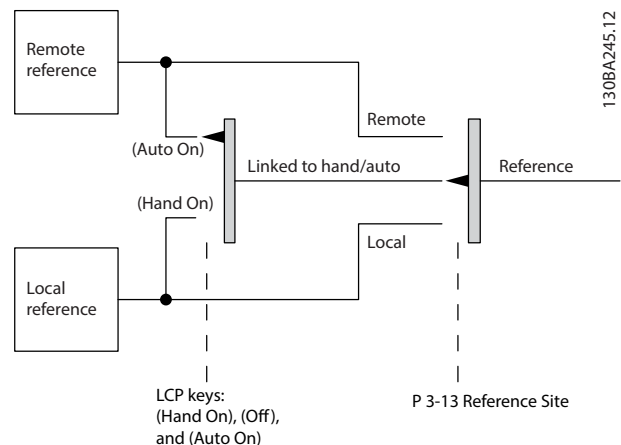

Illustration 11.2 Selecting Active Reference

LCP Keys	Parameter 3-13 Reference Site	Active Reference
[Hand On]	Linked to hand/auto	Local
[Hand On]⇒(Off)	Linked to hand/auto	Local
[Auto On]	Linked to hand/auto	Remote
[Auto On]⇒(Off)	Linked to hand/auto	Remote
All keys	Local	Local
All keys	Remote	Remote

Table 11.1 Local and Remote Reference Configurations

## 11.2.2 Remote Handling of References

Remote handling of reference applies to both open-loop and closed-loop operation. See *Illustration 11.3*.

Up to 8 internal preset references can be programmed into the drive. The active internal preset reference can be selected externally through digital control inputs or through the serial communications bus.

External references can also be supplied to the drive, most commonly through an analog control input. All reference sources and the bus reference are added to produce the total external reference. The active reference can be selected from the following:

- External reference
- Preset reference
- Setpoint
- Sum of the external reference, preset reference, and setpoint

The active reference can be scaled. The scaled reference is calculated as follows:

$$\text{Reference} = X + X \times \left( \frac{Y}{100} \right)$$

Where X is the external reference, the preset reference, or the sum of these references, and Y is *parameter 3-14 Preset Relative Reference* in [%].

If Y, *parameter 3-14 Preset Relative Reference*, is set to 0%, the scaling does not affect the reference.

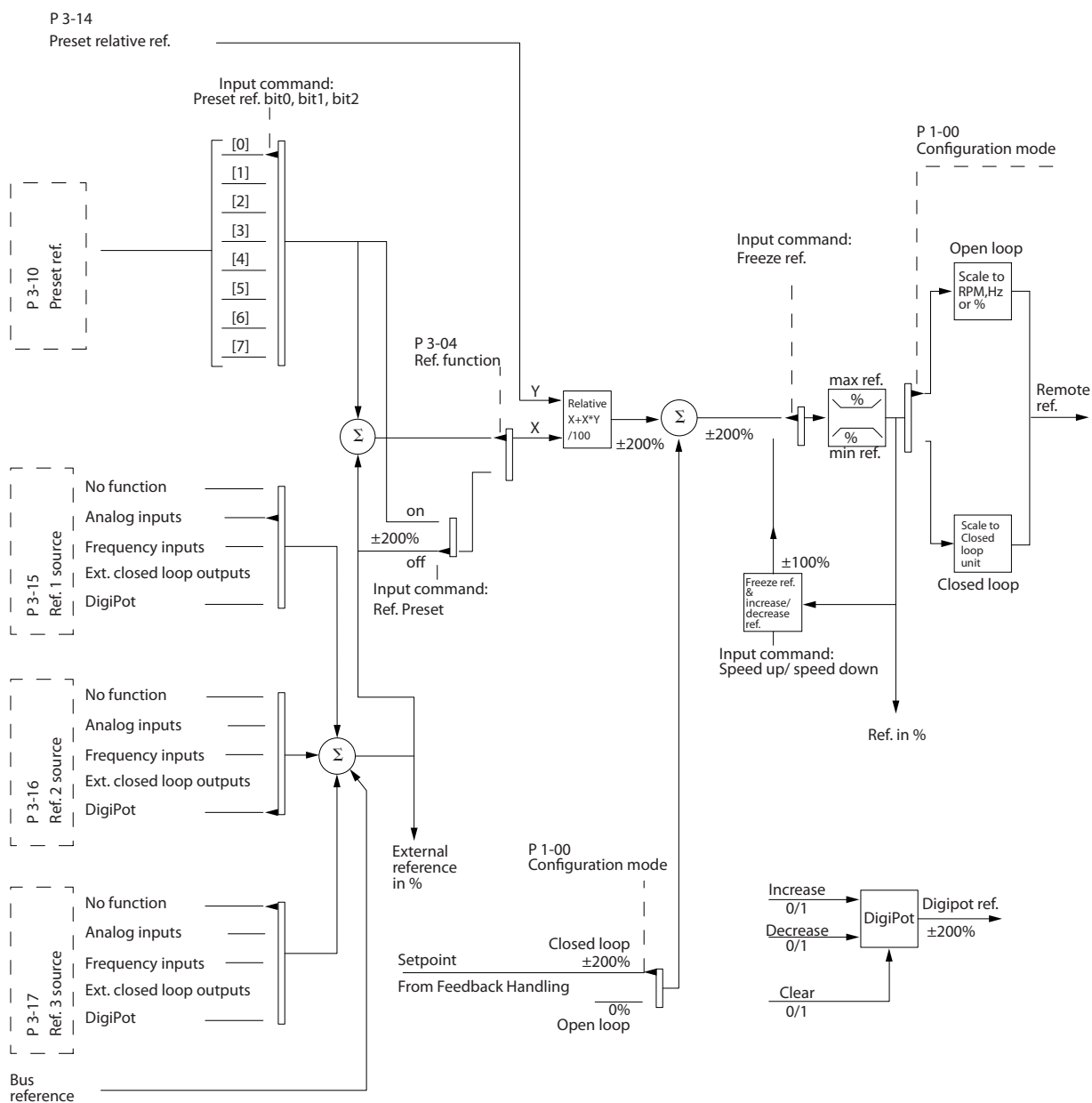

Illustration 11.3 Remote Handling of Reference

11

### 11.2.3 Feedback Handling

Feedback handling can be configured to work with applications requiring advanced control, such as multiple setpoints and multiple types of feedback. See *Illustration 11.4*. Three types of control are common:

**Single zone (single setpoint)**

This control type is a basic feedback configuration. Setpoint 1 is added to any other reference (if any) and the feedback signal is selected.

**Multi-zone (single setpoint)**

This control type uses 2 or 3 feedback sensors but only 1 setpoint. The feedback can be added, subtracted, or averaged. In addition, the maximum or minimum value can be used. Setpoint 1 is used exclusively in this configuration.

**Multi-zone (setpoint/feedback)**

The setpoint/feedback pair with the largest difference controls the speed of the drive. The maximum value attempts to keep all zones at or below their respective setpoints, while the minimum value attempts to keep all zones at or above their respective setpoints.

**Example**

A 2-zone, 2-setpoint application. Zone 1 setpoint is 15 bar, and the feedback is 5.5 bar. Zone 2 setpoint is 4.4 bar, and the feedback is 4.6 bar. If maximum is selected, the zone 2 setpoint and feedback are sent to the PID controller, since it has the smaller difference (feedback is higher than setpoint, resulting in a negative difference). If minimum is selected, the zone 1 setpoint and feedback is sent to the PID controller, since it has the larger difference (feedback is lower than setpoint, resulting in a positive difference).

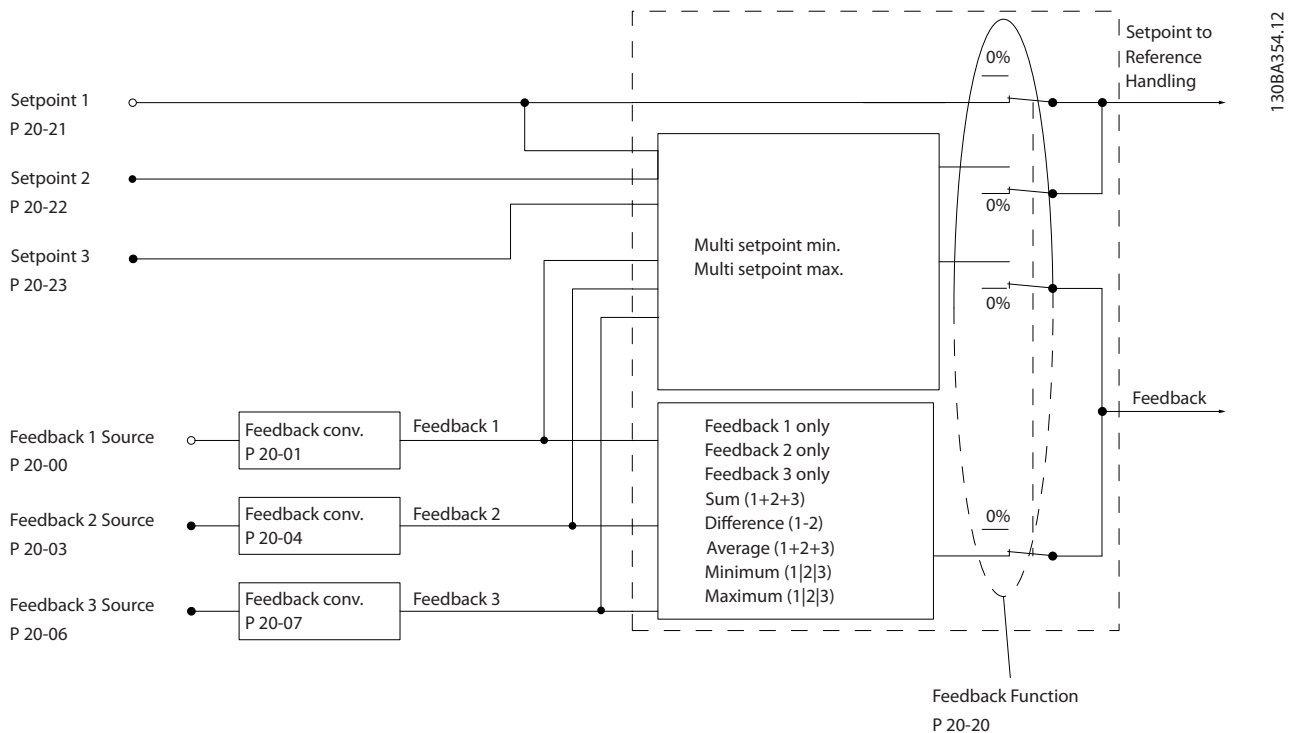
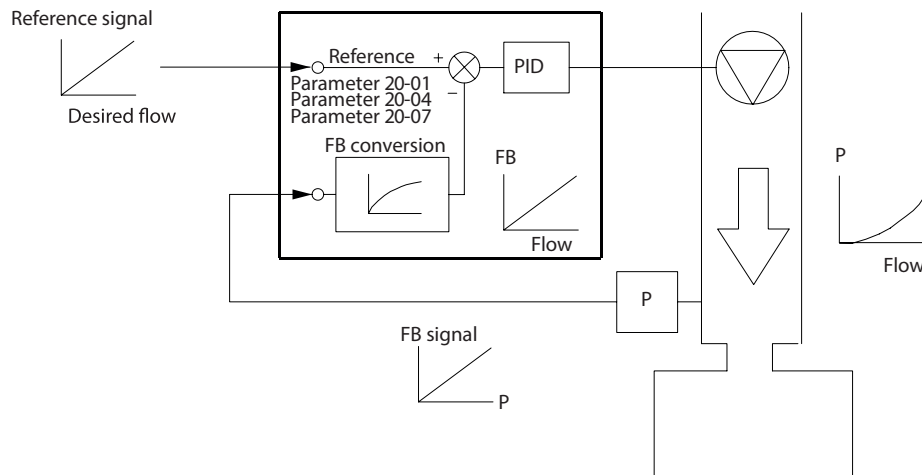

Illustration 11.4 Block Diagram of Feedback Signal Processing

### Feedback conversion

In some applications, it is useful to convert the feedback signal. One example is using a pressure signal to provide flow feedback. Since the square root of pressure is proportional to flow, the square root of the pressure signal yields a value proportional to the flow, see *Illustration 11.5*.



130BF834.10

Illustration 11.5 Feedback Conversion

## 11.2.4 Control Structure Overview

The control structure is a software process that controls the motor based on user-defined references (for example, RPM) and whether feedback is used/not used (closed loop/open loop). The operator defines the control in *parameter 1-00 Configuration Mode*.

11

The control structures are as follows:

### Open-loop control structure

- Speed (RPM)
- Torque (Nm)

### Closed-loop control structure

- Speed (RPM)
- Torque (Nm)
- Process (user-defined units, for example, feet, lpm, psi, %, bar)

## 11.2.5 Open-loop Control Structure

In open-loop mode, the drive uses 1 or more references (local or remote) to control the speed or torque of the motor. There are 2 types of open-loop control:

- Speed control. No feedback from the motor.
- Torque control. Used in VVC<sup>+</sup> mode. The function is used in mechanically robust applications, but its accuracy is limited. Open-loop torque function works only in 1 speed direction. The torque is calculated based on current measurement within the drive. See *chapter 12 Application Examples*.

In the configuration shown in *Illustration 11.6*, the drive operates in open-loop mode. It receives input from either the LCP (hand-on mode) or via a remote signal (auto-on mode). The signal (speed reference) is received and conditioned with the following:

- Programmed minimum and maximum motor speed limits (in RPM and Hz).
- Ramp-up and ramp-down times.
- Motor rotation direction.

The reference is then passed on to control the motor.

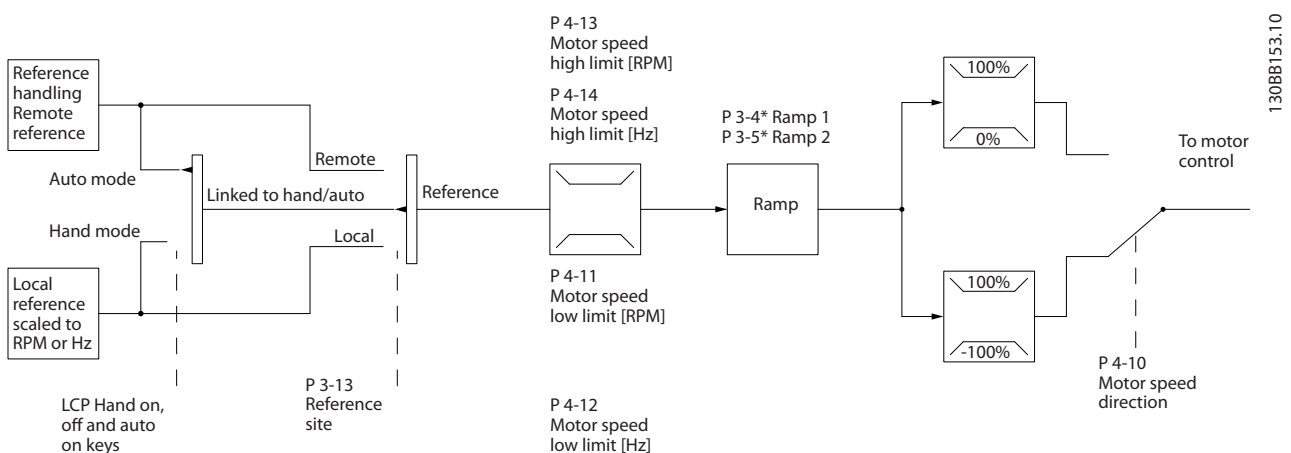

Illustration 11.6 Block Diagram of an Open-loop Control Structure

### 11.2.6 Closed-loop Control Structure

In closed-loop mode, the drive uses 1 or more references (local or remote) and feedback sensors to control the motor. The drive receives a feedback signal from a sensor in the system. It then compares this feedback to a setpoint reference value and determines if there is any discrepancy between these 2 signals. The drive then adjusts the speed of the motor to correct the discrepancy.

For example, consider a pump application in which the speed of the pump is controlled so that the static pressure in a pipe is constant (see *Illustration 11.7*). The drive receives a feedback signal from a sensor in the system. It compares this feedback to a setpoint reference value and determines the discrepancy if any, between these 2 signals. It then adjusts the speed of the motor to compensate for the discrepancy.

The static pressure setpoint is the reference signal to the drive. A static pressure sensor measures the actual static pressure in the pipe and provides this information to the drive as a feedback signal. If the feedback signal exceeds the setpoint reference, the drive ramps down to reduce the pressure. Similarly, if the pipe pressure is lower than the setpoint reference, the drive ramps up to increase the pump pressure.

There are 3 types of closed-loop control:

- Speed control. This type of control requires a speed PID feedback for an input. A properly optimized speed closed-loop control has higher accuracy than a speed open-loop control. Speed control is only used in the VLT<sup>®</sup> AutomationDrive.
- Torque control. Used in flux mode with encoder feedback, this control offers superior performance in all 4 quadrants and at all motor speeds. Torque control is only used in the VLT<sup>®</sup> AutomationDrive. The torque control function is used in applications where the torque on the motor output shaft is controlling the application as tension control. Torque setting is done by setting an analog, digital, or bus-controlled reference.

When running torque control, it is recommended to make a full AMA procedure since the correct motor data is essential for optimal performance.

- Process control. Used to control application parameters that are measured by different sensors (pressure, temperature, and flow) and are affected by the connected motor through a pump or fan.

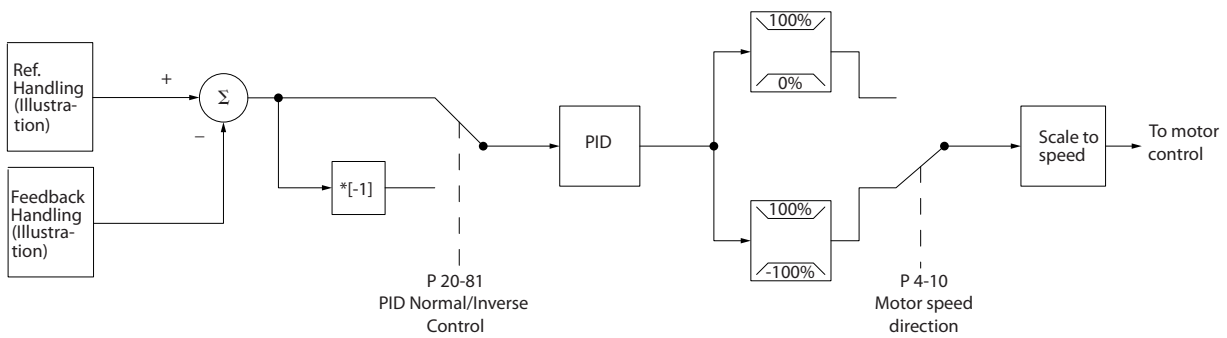

Illustration 11.7 Block Diagram of Closed-loop Controller

**Programmable features**

While the default values for the drive in closed loop often provide satisfactory performance, system control can often be optimized by tuning the PID parameters. *Auto tuning* is provided for this optimization.

- Inverse regulation - motor speed increases when a feedback signal is high.
- Start-up frequency - lets the system quickly reach an operating status before the PID controller takes over.
- Built-in lowpass filter - reduces feedback signal noise.

11

11.2.7 Control Processing

See *Active/Inactive Parameters in Different Drive Control Modes* in the *programming guide* for an overview of which control configuration is available for your application, depending on selection of AC motor or PM non-salient motor.



### 11.2.7.1 Control Structure in VVC<sup>+</sup>

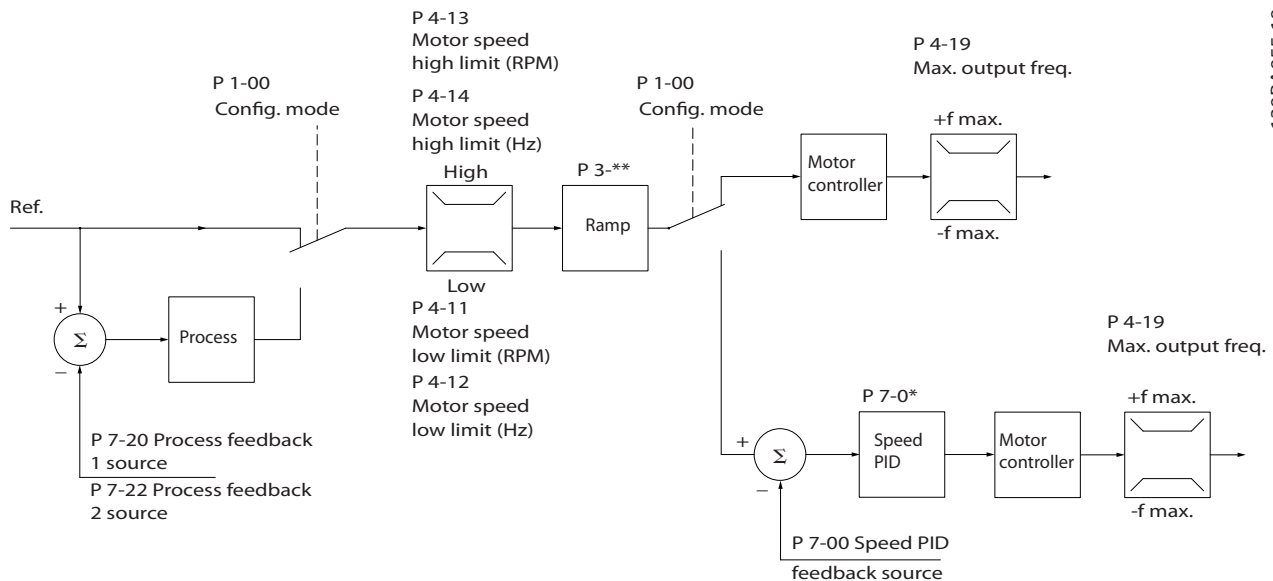

130BA055.10

Illustration 11.8 Control Structure in VVC<sup>+</sup> Open Loop and Closed-loop Configurations

In *Illustration 11.8*, the resulting reference from the reference handling system is received and fed through the ramp limitation and speed limitation before being sent to the motor control. The output of the motor control is then limited by the maximum frequency limit.

*Parameter 1-01 Motor Control Principle* is set to [1] VVC<sup>+</sup> and *parameter 1-00 Configuration Mode* is set to [0] Speed open loop. If *parameter 1-00 Configuration Mode* is set to [1] Speed closed loop, the resulting reference is passed from the ramp limitation and speed limitation into a speed PID control. The speed PID control parameters are located in *parameter group 7-0\* Speed PID Ctrl.* The resulting reference from the speed PID control is sent to the motor control limited by the frequency limit.

Select [3] Process in *parameter 1-00 Configuration Mode* to use the process PID control for closed-loop control of, for example, speed or pressure in the controlled application. The process PID parameters are in *parameter groups 7-2\* Process Ctrl. Feedb* and *7-3\* Process PID Ctrl.*

### 11.2.7.2 Internal Current Control in VVC<sup>+</sup> Mode

When the motor torque exceeds the torque limits set in *parameter 4-16 Torque Limit Motor Mode*, *parameter 4-17 Torque Limit Generator Mode*, and *parameter 4-18 Current Limit*, the integral current limit control is activated.

When the drive is at the current limit during motor operation or regenerative operation, it tries to get below the preset torque limits as quickly as possible without losing control of the motor.

## 12 Application Examples

The examples in this section are intended as a quick reference for common applications.

- Parameter settings are the regional default values unless otherwise indicated (selected in *parameter 0-03 Regional Settings*).
- Parameters associated with the terminals and their settings are shown next to the drawings.
- Switch settings for analog terminals A53 or A54 are shown where required.
- For STO, a jumper wire may be required between terminal 12 and terminal 37 when using factory default programming values.

### 12.1 Wiring Configurations for Automatic Motor Adaptation (AMA)

		Parameters	
FC		Function	Setting
+24 V	12	Parameter 1-29 Automatic Motor Adaptation (AMA)	[1] Enable complete AMA
+24 V	13		
D IN	18		
D IN	19		
COM	20	Parameter 5-12 T erminal 27 Digital Input	[2]* Coast inverse
D IN	27		
D IN	29		
D IN	32		
D IN	33	* = Default value	
D IN	37	Notes/comments: Set parameter group 1-2* Motor Data according to motor nameplate.	
+10 V	50		
A IN	53		
A IN	54		
COM	55		
A OUT	42		
COM	39		

Table 12.1 Wiring Configuration for AMA with T27 Connected

		Parameters	
FC		Function	Setting
+24 V	12	Parameter 1-29 Automatic Motor Adaptation (AMA)	[1] Enable complete AMA
+24 V	13		
D IN	18		
D IN	19		
COM	20	Parameter 5-12 T erminal 27 Digital Input	[0] No operation
D IN	27		
D IN	29		
D IN	32		
D IN	33	* = Default value	
D IN	37	Notes/comments: Set parameter group 1-2* Motor Data according to motor nameplate.	
+10 V	50		
A IN	53		
A IN	54		
COM	55		
A OUT	42		
COM	39		

Table 12.2 Wiring Configuration for AMA without T27 Connected

### 12.2 Wiring Configurations for Analog Speed Reference

		Parameters	
FC		Function	Setting
+10 V	50	Parameter 6-10 T erminal 53 Low Voltage	0.07 V*
A IN	53		
A IN	54	Parameter 6-11 T erminal 53 High Voltage	10 V*
COM	55	Parameter 6-14 T erminal 53 Low Ref./Feedb. Value	0 RPM
A OUT	42	Parameter 6-15 T erminal 53 High Ref./Feedb. Value	1500 RPM
COM	39	* = Default value	
Notes/comments:			

Table 12.3 Wiring Configuration for Analog Speed Reference (Voltage)

		Parameters	
FC		Function	Setting
	e30bb927.1.1	Parameter 6-12 Terminal 53 Low Current	4 mA*
		Parameter 6-13 Terminal 53 High Current	20 mA*
		Parameter 6-14 Terminal 53 Low Ref./Feedb. Value	0 RPM
		Parameter 6-15 Terminal 53 High Ref./Feedb. Value	1500 RPM
		* = Default value	
<b>Notes/comments:</b>			

Table 12.4 Wiring Configuration for Analog Speed Reference (Current)

### 12.3 Wiring Configurations for Start/Stop

		Parameters	
FC		Function	Setting
	130BB802.10	Parameter 5-10 Terminal 18 Digital Input	[8] Start*
		Parameter 5-12 Terminal 27 Digital Input	[0] No operation
		Parameter 5-19 Terminal 37 Safe Stop	[1] Safe Torque Off Alarm
		* = Default value	
<b>Notes/comments:</b>			
If parameter 5-12 Terminal 27 Digital Input is set to [0] No operation, a jumper wire to terminal 27 is not needed.			

Table 12.5 Wiring Configuration for Start/Stop Command with Safe Torque Off

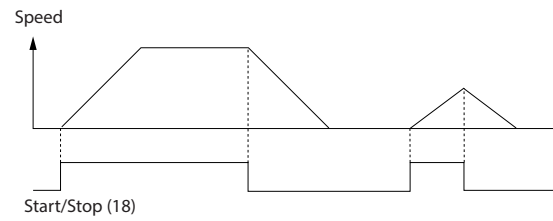

Illustration 12.1 Start/Stop with Safe Torque Off

		Parameters			
FC		Function	Setting		
	130BB803.10	Parameter 5-10 Terminal 18 Digital Input	[9] Latched Start		
		Parameter 5-12 Terminal 27 Digital Input	[6] Stop Inverse		
		* = Default value			
		<b>Notes/comments:</b>			
If parameter 5-12 Terminal 27 Digital Input is set to [0] No operation, a jumper wire to terminal 27 is not needed.					

Table 12.6 Wiring Configuration for Pulse Start/Stop

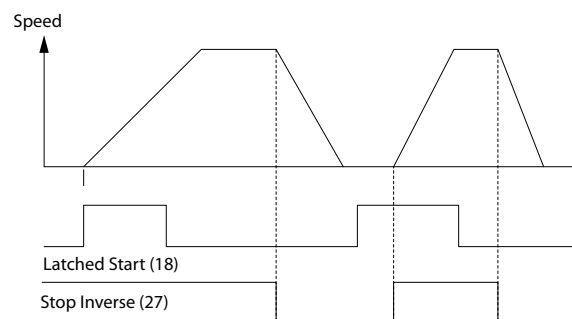

Illustration 12.2 Latched Start/Stop Inverse

		Parameters	
FC		Function	Setting
+24 V	12	Parameter 5-10 Terminal 18	[8] Start
+24 V	13	Digital Input	
D IN	18	Parameter 5-11 Terminal 19	[10] Reversing*
D IN	19	Digital Input	
COM	20	Parameter 5-12 Terminal 27	[0] No operation
D IN	27	Digital Input	
D IN	29	Parameter 5-14 Terminal 32	[16] Preset ref bit 0
D IN	32	Digital Input	
D IN	33	Parameter 5-15 Terminal 33	[17] Preset ref bit 1
D IN	33	Digital Input	
+10 V	50	Parameter 3-10 Preset Reference	
A IN	53	Preset ref. 0	25%
A IN	54	Preset ref. 1	50%
COM	55	Preset ref. 2	75%
A OUT	42	Preset ref. 3	100%
COM	39	*=Default value	
Notes/comments:			

Table 12.7 Wiring Configuration for Start/Stop with Reversing and 4 Preset Speeds

### 12.4 Wiring Configuration for an External Alarm Reset

		Parameters	
FC		Function	Setting
+24 V	12	Parameter 5-11 Terminal 19	[1] Reset
+24 V	13	Digital Input	
D IN	18	*=Default value	
D IN	19	Notes/comments:	
COM	20		
D IN	27		
D IN	29		
D IN	32		
D IN	33		
D IN	37		
+10 V	50		
A IN	53		
A IN	54		
COM	55		
A OUT	42		
COM	39		
Notes/comments:			

Table 12.8 Wiring Configuration for an External Alarm Reset

### 12.5 Wiring Configuration for Speed Reference Using a Manual Potentiometer

		Parameters	
FC		Function	Setting
+10 V	50	Parameter 6-10 Terminal 53 Low Voltage	0.07 V*
A IN	53	Parameter 6-11 Terminal 53 High Voltage	10 V*
A IN	54	Parameter 6-14 Terminal 53 Low Ref./Feedb. Value	0 RPM
COM	55	Parameter 6-15 Terminal 53 High Ref./Feedb. Value	1500 RPM
A OUT	42	*=Default value	
COM	39	Notes/comments:	

Table 12.9 Wiring Configuration for Speed Reference (Using a Manual Potentiometer)

### 12.6 Wiring Configuration for Speed Up/Speed Down

		Parameters	
		Function	Setting
		Parameter 5-10 Terminal 18	[8] Start*
		Parameter 5-12 Terminal 27	[19] Freeze Reference
		Parameter 5-13 Terminal 29	[21] Speed Up
		Parameter 5-14 Terminal 32	[22] Speed Down
		* = Default value	
		Notes/comments:	

Table 12.10 Wiring Configuration for Speed Up/Speed Down

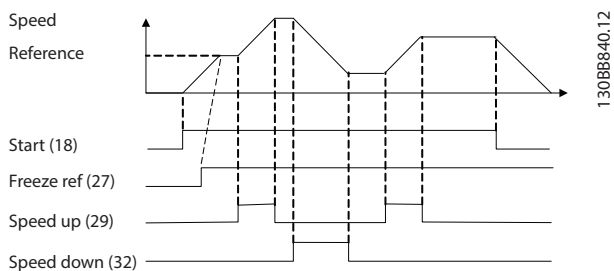

Illustration 12.3 Speed Up/Speed Down

### 12.7 Wiring Configuration for RS485 Network Connection

		Parameters	
		Function	Setting
		Parameter 8-30 Protocol	FC*
		Parameter 8-31 Address	1*
		Parameter 8-32 Baud Rate	9600*
		* = Default value	
		Notes/comments: Select protocol, address, and baud rate in the parameters.	

Table 12.11 Wiring Configuration for RS485 Network Connection

## 12.8 Wiring Configuration for a Motor Thermistor

### NOTICE

Thermistors must use reinforced or double insulation to meet PELV insulation requirements.

		Parameters	
		Function	Setting
		Parameter 1-90 Motor Thermal Protection	[2] Thermistor trip
		Parameter 1-93 T hermistor Source	[1] analog input 53
		*=-Default value	
		<b>Notes/comments:</b> If only a warning is wanted, set parameter 1-90 Motor Thermal Protection to [1] Thermistor warning.	

12

Table 12.12 Wiring Configuration for a Motor Thermistor

## 12.9 Wiring Configuration for Cascade Controller

Illustration 12.4 shows an example with the built-in basic cascade controller with 1 variable-speed pump (lead) and 2 fixed-speed pumps, a 4–20 mA transmitter, and system safety interlock.

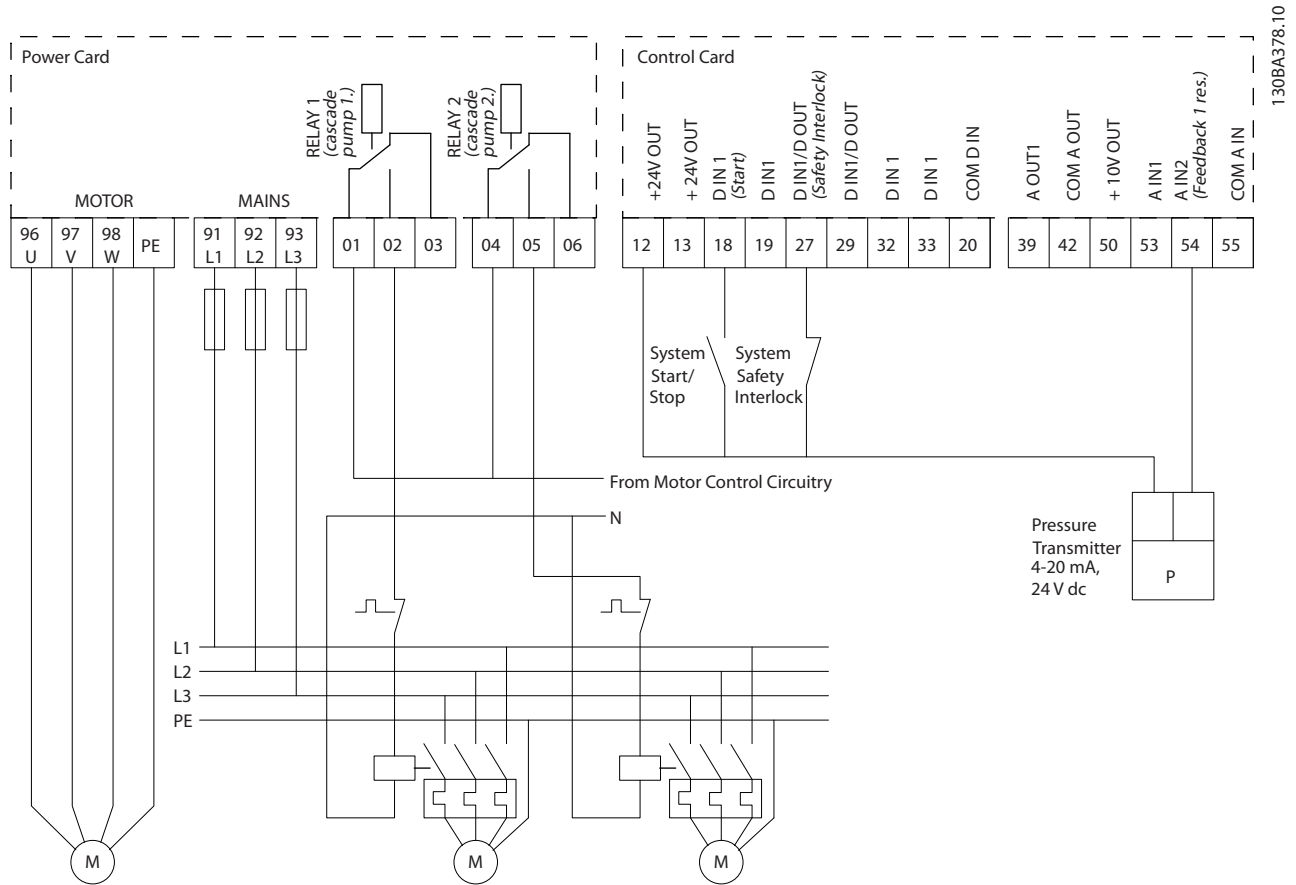

Illustration 12.4 Cascade Controller Wiring Diagram

### 12.10 Wiring Configuration for a Relay Set-up with Smart Logic Control

		Parameters	
FC		Function	Setting
+24 V	12	Parameter 4-30	[1] Warning Motor Feedback Loss Function
+24 V	13	Parameter 4-31	100 RPM Motor Feedback Speed Error
D IN	18	Parameter 4-32	5 s Motor Feedback Loss Timeout
D IN	19	Parameter 7-00	[2] MCB 102 speed PID Feedback Source
COM	20	Parameter 17-11	1024* Resolution (PPR)
D IN	27	Parameter 13-00	[1] On SL Controller Mode
D IN	29	Parameter 13-01	[19] Warning Start Event
D IN	32	Parameter 13-02	[44] Reset key Stop Event
D IN	33	Parameter 13-10	[21] Warning no. Comparator Operand
D IN	37	Parameter 13-11	[1] ≈ (equal)* Comparator Operator
+10 V	50	Parameter 13-12	90 Comparator Value
A IN	53	Parameter 13-51	[22] SL Controller Comparator 0 Event
A IN	54	Parameter 13-52	[32] Set digital out A low Action
COM	55	Parameter 5-40	[80] SL digital unction Relay output A
A OUT	42		
COM	39		
	01		
	02		
	03		
	04		
	05		
	06		

Notes/comments:  
 If the limit in the feedback monitor is exceeded, warning 90, Feedback Mon. is issued. The SLC monitors warning 90, Feedback Mon. and if the warning becomes true, relay 1 is triggered. External equipment may require service. If the feedback error goes below the limit again within 5 s, the drive continues and the warning disappears. Reset relay 1 by pressing [Reset] on the LCP.

Table 12.13 Wiring Configuration for a Relay Set-up with Smart Logic Control

### 12.11 Wiring Configuration for a Fixed Variable-speed Pump

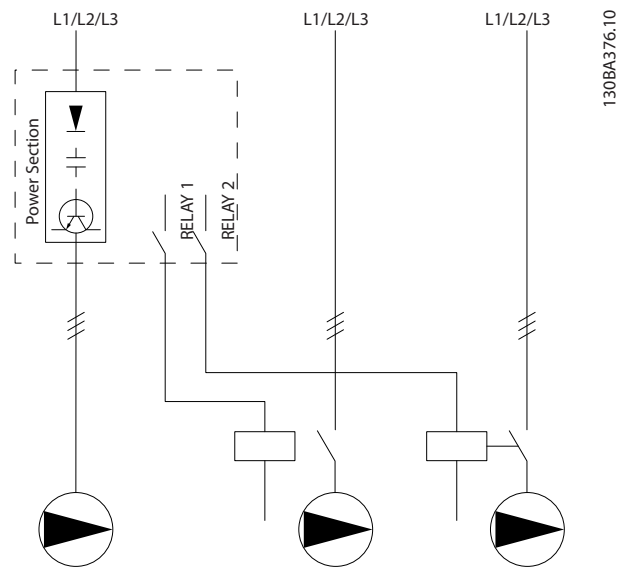

Illustration 12.5 Fixed Variable Speed Pump Wiring Diagram

### 12.12 Wiring Configuration for Lead Pump Alternation

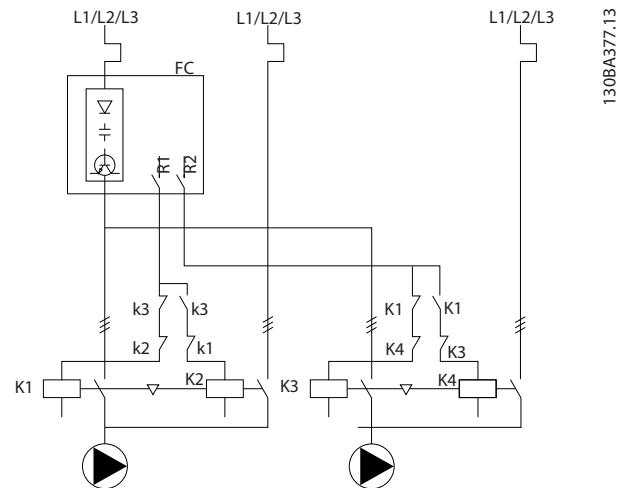

Illustration 12.6 Lead Pump Alternation Wiring Diagram.

Every pump must be connected to 2 contactors (K1/K2 and K3/K4) with a mechanical interlock. Thermal relays or other motor overload protection devices must be applied according to local regulation and/or individual demands.

- Relay 1 (R1) and relay 2 (R2) are the built-in relays in the drive.
- When all relays are de-energized, the 1<sup>st</sup> built-in relay that is energized cuts in the contactor corresponding to the pump controlled by the



relay. For example, relay 1 cuts in contactor K1, which becomes the lead pump.

- K1 blocks for K2 via the mechanical interlock, preventing mains from being connected to the output of the drive (via K1).
- Auxiliary break contact on K1 prevents K3 from cutting in.
- Relay 2 controls contactor K4 for on/off control of the fixed speed pump.
- At alternation, both relays de-energize and now relay 2 is energized as the 1<sup>st</sup> relay.

# 13 How to Order a Drive

## 13.1 Drive Configurator

1	2	3	4	5	6	7	8	9	10	11	12	13	14	15	16	17	18	19	20	21	22	23	24	25	26	27	28	29	30	31	32	33	34	35	36	37	38	39
F	C	-								T											X	X	S	X	X	X	X	A		B		C						D

130BC530.10

**Table 13.1 Type Code String**

Product group	1-6	<input type="text"/>
Model	7-10	<input type="text"/>
Mains Voltage	11-12	<input type="text"/>
Enclosure	13-15	<input type="text"/>
Hardware configuration	16-23	<input type="text"/>
RFI filter/low harmonic drive/ 12-pulse	16-17	<input type="text"/>
Brake	18	<input type="text"/>
Display (LCP)	19	<input type="text"/>
PCB coating	20	<input type="text"/>
Mains option	21	<input type="text"/>
Adaptation A	22	<input type="text"/>
Adaptation B	23	<input type="text"/>
Software release	24-27	<input type="text"/>
Software language	28	<input type="text"/>
A options	29-30	<input type="text"/>
B options	31-32	<input type="text"/>
C0 options, MCO	33-34	<input type="text"/>
C1 options	35	<input type="text"/>
C option software	36-37	<input type="text"/>
D options	38-39	<input type="text"/>

**Table 13.2 Type Code Example for Ordering a Drive**

Configure the correct drive for the proper application by using the internet-based drive configurator. The drive configurator is found on the global internet site: [www.danfoss.com/drives](http://www.danfoss.com/drives). The configurator creates a type code string and an 8-digit sales number, which can be delivered to the local sales office. It is also possible to build a project list with several products and send it to a Danfoss sales representative.

An example of a type code string is:

FC-102P450T5E54H4CGCXXXSXXXXA0BXCXXXX0

The meaning of the characters in the string is defined in this chapter. In the example above, an F3 drive is configured with the following options:

- RFI filter
- Safe Torque Off with Pilz relay
- Coated PCB
- PROFIBUS DP-V1

Drives are delivered automatically with a language package relevant to the region from which they are ordered. Four regional language packages cover the following languages:

**Language package 1**

English, German, French, Danish, Dutch, Spanish, Swedish, Italian, and Finnish.

**Language package 2**

English, German, Chinese, Korean, Japanese, Thai, Traditional Chinese, and Bahasa Indonesian.

**Language package 3**

English, German, Slovenian, Bulgarian, Serbian, Romanian, Hungarian, Czech, and Russian.

**Language package 4**

English, German, Spanish, English US, Greek, Brazilian Portuguese, Turkish, and Polish.

To order drives with a different language package, contact the local Danfoss sales office.

## 13.1.1 Ordering Type Code for Enclosures E1–E2

Description	Pos	Possible option
Product group	1–6	FC-102
Model	8–10	P355–P630
Mains voltage	11–12	T4: 380–480 V AC T7: 525–690 V AC
Enclosure	13–15	E00: IP00 (chassis - for installation in an external enclosure) C00: IP00/Chassis with stainless steel back channel E21: IP21 (NEMA 1) E54: IP54 (NEMA 12) E2M: IP21 (NEMA 1) with mains shield E5M: IP54 (NEMA 12) with mains shield
RFI filter	16–17	H2: RFI filter, class A2 (standard) H4: RFI filter class A1 <sup>1)</sup> B2: 12-pulse drive with RFI filter, class A2 B4: 12-pulse drive with RFI filter, class A1 N2: LHD with RFI filter, class A2 N4: LHD with RFI filter, class A1
Brake	18	B: Brake IGBT mounted X: No brake IGBT R: Regen terminals S: Brake + regen
Display	19	G: Graphical local control panel LCP N: Numerical local control panel (LCP) X: No local control panel
PCB coating	20	C: Coated PCB
Mains option	21	X: No mains option 3: Mains disconnect and fuse 5: Mains disconnect, fuse, and load sharing 7: Fuse A: Fuse and load sharing D: Load sharing
Adaptation	22	X: Standard cable entries
Adaptation	23	X: No adaptation
Software release	24–27	Actual software
Software language	28	X: Standard language pack

 Table 13.3 Ordering Type Code for Enclosures E1–E2<sup>2)</sup>

1) Available for 380–480 V only.

2) Consult the factory for applications requiring maritime certification.

## 13.1.2 Ordering Type Code for Enclosures F1–F4 and F8–F13

Description	Pos	Possible option
Product group	1–6	FC-102
Model	8–10	P315–P1400 kW
Mains voltage	11–12	T4: 380–480 V AC T7: 525–690 V AC
Enclosure	13–15	C21: IP21/NEMA Type 1 with stainless steel back channel C54: IP54/Type 12 stainless steel back channel E21: IP 21/ NEMA Type 1 E54: IP 54/ NEMA Type 12 L2X: IP21/NEMA 1 with cabinet light, and IEC 230 V power outlet L5X: IP54/NEMA 12 with cabinet light, and IEC 230 V power outlet L2A: IP21/NEMA 1 with cabinet light, and NAM 115 V power outlet L5A: IP54/NEMA 12 with cabinet light, and NAM 115 V power outlet H21: IP21 with space heater and thermostat H54: IP54 with space heater and thermostat R2X: IP21/NEMA1 with space heater, thermostat, light, and IEC 230 V outlet R5X: IP54/NEMA12 with space heater, thermostat, light, and IEC 230 V outlet R2A: IP21/NEMA1 with space heater, thermostat, light, and NAM 115 V outlet R5A: IP54/NEMA12 with space heater, thermostat, light, and NAM 115 V outlet
RFI filter	16–17	H2: RFI filter, class A2 (standard) H4: RFI filter, class A1 HE: RCD with class A2 RFI filter HF: RCD with class A1 RFI filter HG: IRM with class A2 RFI filter HH: IRM with class A1 RFI filter HJ: NAMUR terminals and class A2 RFI filter HK: NAMUR terminals with class A1 RFI filter HL: RCD with NAMUR terminals and class A2 RFI filter HM: RCD with NAMUR terminals and class A1 RFI filter HN: IRM with NAMUR terminals and class A2 RFI filter HP: IRM with NAMUR terminals and class A1 RFI filter N2: Low harmonic drive with RFI filter, class A2 N4: Low harmonic drive with RFI filter, class A1 B2: 12-pulse drive with RFI filter, class A2 B4: 12-pulse drive with RFI filter, class A1 BE: 12-pulse + RCD for TN/TT mains + class A2 RFI BF: 12-pulse + RCD for TN/TT mains + class A1 RFI BG: 12-pulse + IRM for IT mains + class A2 RFI BH: 12-pulse + IRM for IT mains + class A1 RFI BM: 12-pulse + RCD for TN/TT mains + NAMUR terminals + class A1 RFI <sup>1)</sup>
Brake	18	B: Brake IGBT mounted X: No brake IGBT C: Safe Torque Off with Pilz safety relay D: Safe Torque Off with Pilz safety relay, and brake IGBT R: Regen terminals M: IEC emergency stop push button (with Pilz safety relay) N: IEC emergency stop push button with brake IGBT and brake terminals P: IEC emergency stop push button with regen terminals
Display	19	G: Graphical Local Control Panel LCP
PCB coating	20	C: Coated PCB

Description	Pos	Possible option
Mains option	21	X: No mains option 3: Mains disconnect and fuse 5: Mains disconnect, fuse, and load sharing 7: Fuse A: Fuse and load sharing D: Load sharing E: Mains disconnect, contactor, and fuses F: Mains circuit breaker, contactor, and fuses G: Mains disconnect, contactor, load sharing terminals, and fuses H: Mains circuit breaker, contactor, load sharing terminals, and fuses J: Mains circuit breaker and fuses K: Mains circuit breaker, load sharing terminals, and fuses
Power terminals & motor starters	22	X: No option E 30 A, fuse-protected power terminals F: 30 A, fuse-protected power terminals and 2.5–4 A manual motor starter G: 30 A, fuse-protected power terminals and 4–6.3 A manual motor starter H: 30 A, fuse-protected power terminals and 6.3–10 A manual motor starter J: 30 A, fuse-protected power terminals and 10–16 A manual motor starter K: Two 2.5–4 A manual motor starters L: Two 4–6.3 A manual motor starters M: Two 6.3–10 A manual motor starters N: Two 10–16 A manual motor starters
Auxiliary 24 V supply & external temperature monitoring	23	X: No option H: 5 A, 24 V supply (customer use) J: External temperature monitoring G: 5 A, 24 V supply (customer use) and external temperature monitoring
Software release	24–27	Actual software
Software language	28	X: Standard language pack

**Table 13.4 Ordering Type Code for Enclosures F1–F4 and F8–F13<sup>2)</sup>**

 1) Requires VLT<sup>®</sup> PTC Thermistor Card MCB 112 and VLT<sup>®</sup> Extended Relay Card MCB 113.

### 13.1.3 Ordering Options for All VLT® HVAC Drive FC 102 Enclosures

Description	Pos	Possible option
A options	29–30	AX: No A option A0: VLT® PROFIBUS DP V1 MCA 101 A4: VLT® DeviceNet MCA 104 AG: VLT® LonWorks MCA 108 AJ: VLT® BACnet MCA 109 AK: VLT® BACnet/IP MCA 125 AL: VLT® PROFINET MCA 120 AN: VLT® EtherNet/IP MCA 121 AQ: VLT® POWERLINK MCA 122
B options	31–32	BX: No option B0: VLT® Analog I/O Option MCB 109 B2: VLT® PTC Thermistor Card MCB 112 B4: VLT® Sensor Input Option MCB 114 BK: VLT® General Purpose I/O Module MCB 101 BP: VLT® Relay Card MCB 105
C0/ E0 options	33–34	CX: No option
C1 options/ A/B in C option adapter	35	X: No option R: VLT® Extended Relay Card MCB 113
C option software/ E1 options	36–37	XX: Standard controller
D options	38–39	DX: No option D0: VLT® 24 V DC Supply MCB 107

Table 13.5 Ordering Type Code for FC 102 Options

## 13.2 Ordering Numbers for Options/Kits

### 13.2.1 Ordering Numbers for D Option: 24 V Back-up Supply

Description	Ordering number	
	Uncoated	Coated
VLT® 24 V DC Supply MCB 107	130B1108	130B1208

Table 13.6 Ordering Numbers for D Option

### 13.2.2 Ordering Numbers for Software Options

Description	Ordering number
VLT® MCT 10 Set-up Software - 1 user.	130B1000
VLT® MCT 10 Set-up Software - 5 users.	130B1001
VLT® MCT 10 Set-up Software - 10 users.	130B1002
VLT® MCT 10 Set-up Software - 25 users.	130B1003
VLT® MCT 10 Set-up Software - 50 users.	130B1004
VLT® MCT 10 Set-up Software - 100 users.	130B1005
VLT® MCT 10 Set-up Software - unlimited users.	130B1006

Table 13.7 Ordering Numbers for Software Options

### 13.2.3 Ordering Numbers for Kits

Type	Description	Ordering number
Miscellaneous hardware		
USB in door, E1 and F1-F13	USB extension cord kit to allow access to the drive controls via laptop computer without opening the drive.	E1-E2 – 130B1156 F1-F13 – 176F1784
Top entry - motor cables, F1/F3	Allows for the installation of motor cables through the top of the motor side cabinet. Must be used with the common motor terminals kit. Only for enclosures F1/F3.	400 mm (15.7 in) cabinet – 176F1838 600 mm (23.6 in) cabinet – 176F1839
Top entry - motor cables, F2/F4	Allows for the installation of motor cables through the top of the motor side cabinet. Must be used with the common motor terminals kit. Only for enclosures F2/F4.	400 mm (15.7 in) cabinet – 176F1840 600 mm (23.6 in) cabinet – 176F1841
Top entry - motor cables, F8-F13	Allows for the installation of motor cables through the top of the motor side cabinet. Must be used with the common motor terminals kit. Only for enclosures F8-F13.	Contact factory
Top entry - mains cables, F1-F2	Allows for the installation of mains cables through the top of the mains side cabinet. The kit must be ordered with the common motor terminals kit. Only for enclosures F1-F2.	400 mm (15.7 in) cabinet – 176F1832 600 mm (23.6 in) cabinet – 176F1833
Top entry - mains cables, F3-F4 with disconnect	Allows for the installation of mains cables through the top of the mains side cabinet. The kit must be ordered with the common motor terminals kit. Only for enclosures F3-F4 with disconnect.	400 mm (15.7 in) cabinet – 176F1834 600 mm (23.6 in) cabinet – 176F1835
Top entry - mains cables, F3-F4	Allows for the installation of mains cables through the top of the mains side cabinet. The kit must be ordered with the common motor terminals kit. Only for enclosures F3-F4.	400 mm (15.7 in) cabinet – 176F1836 600 mm (23.6 in) cabinet – 176F1837
Top entry - mains cables, F8-F13	Allows for the installation of mains cables through the top of the mains side cabinet. The kit must be ordered with the common motor terminals kit. Only for enclosures F8-F13.	Contact factory
Top entry - fieldbus cables, E2	Allows for the installation of fieldbus cables through the top of the drive. The kit is IP20/Chassis when installed, but a different mating connector can be used to increase the protection rating. Only for enclosure E2.	176F1742
Common motor terminals, F1-F4	Provides the busbars and hardware required to connect the motor terminals from the paralleled inverters to a single terminal (per phase) to accommodate the installation of the motor-side top entry kit. This kit is equivalent to the common motor terminal option of a drive. This kit is not required to install the motor-side top entry kit if the common motor terminal option was specified when the drive was ordered. Also recommended to connect the output of a drive to an output filter or output contactor. The common motor terminals eliminate the need for equal cable lengths from each inverter to the common point of the output filter (or motor).	400 mm (15.7 in) cabinet – 176F1845 600 mm (23.6 in) cabinet – 176F1846
NEMA 3R enclosure, E2	Designed to be used with the IP00/IP20/Chassis drives to achieve an ingress protection rating of NEMA 3R or NEMA 4. These enclosures are intended for outdoor use to provide a degree of protection against inclement weather. Only for enclosures E2.	Welded enclosure – 176F0298 Rittal enclosure – 176F1852
Pedestal, E1-E2	The pedestal kit is a 400 mm (15.8 in) high pedestal that allows the drive to be floor mounted. The front of the pedestal has openings for input air to cool the power components. Only for enclosures E1-E2.	176F6739
Input options plate, E1-E2	Allows fuses, disconnect/fuses, RFI, RFI/fuses, and RFI/disconnect/fuses to be added. Only for enclosures E1-E2.	Contact factory

Type	Description	Ordering number
IP20 conversion, E2	Provides the drive with an ingress protection rating of IP20/Protected Chassis. Only for E2 enclosure.	176F1884
<b>Back-channel cooling kits</b>		
In back/out back, E1	Allows the cooling air to be directed in and out through the back of the drive. Kit includes top and base covers for an E1 with protection rating of IP21/54 (Type1/12).	176F1946
In back/out back, E2	Allows the cooling air to be directed in and out through the back of the drive. Kit includes top and base covers for an E2 with a protection rating of IP00 (Chassis).	Welded enclosure – 176F1861 Rittal enclosure – 176F1783
In back/out back, F1–F13	Allows the cooling air to be directed in and out through the back of the drive. Plates are already included on drive. Contact factory for installation instructions.	Contact factory
In bottom/out top, E2	Allows the cooling air to be directed in through the bottom and out through the top of the drive. This kit used only for enclosure E2.	2000 mm (78.7 in) cabinet – 176F1850 2200 mm (86.6 in) cabinet – 176F0299
Out top, E2	Allows the cooling air to be directed out through the top of the drive. This kit used only for enclosure E2.	176F1776
<b>LCP</b>		
LCP 101	Numerical local control panel (NLCP)	130B1124
LCP 102	Graphical local control panel (GLCP)	130B1107
LCP cable	Separate LCP cable, 3 m (9 ft)	175Z0929
LCP kit, IP21	Panel mounting kit including graphical LCP, fasteners, 3 m (9 ft) cable, and gasket	130B1113
LCP kit, IP21	Panel mounting kit including numerical LCP, fasteners, and gasket	130B1114
LCP kit, IP21	Panel mounting kit for all LCPs including fasteners, 3 m (9 ft) cable, and gasket	130B1117

Table 13.8 Kits Available for Enclosures E1–E2 and F1–F13

### 13.2.4 Ordering Numbers for A Options: Fieldbuses

Description	Ordering number	
	Uncoated	Coated
VLT® PROFIBUS DP MCA 101	130B1100	130B1200
VLT® DeviceNet MCA 104	130B1102	130B1202
VLT® LonWorks MCA 108	130B1106	130B1206
VLT® BACnet MCA 109	130B1144	130B1244
VLT® PROFINET MCA 120	130B1135	130B1235
VLT® EtherNet/IP MCA 121	130B1119	130B1219
VLT® Modbus TCP MCA 122	130B1196	130B1296
VLT® Powerlink MCA 123	130B1489	130B1490
VLT® VACnet/IP MCA 125	–	130B1586

Table 13.9 Ordering Numbers for A Options

For information on fieldbus and application option compatibility with older software versions, contact the Danfoss supplier.



### 13.2.5 Ordering Numbers for B Options: Functional Extensions

Description	Ordering number	
	Uncoated	Coated
VLT® General Purpose I/O MCB 101	130B1125	130B1212
VLT® Relay Card MCB 105	130B1110	130B1210
VLT® Analog I/O MCB 109	130B1143	130B1243
VLT® PTC Thermistor Card MCB 112	–	130B1137
VLT® Sensor Input MCB 114	130B1172	130B1272

Table 13.10 Ordering Numbers for B Options

### 13.2.6 Ordering Numbers for C Options: Motion Control and Relay Card

Description	Ordering number	
	Uncoated	Coated
VLT® Extended Relay Card MCB 113	130B1164	130B1264

Table 13.11 Ordering Numbers for C Options

## 13.3 Ordering Numbers for Filters and Brake Resistors

Refer to the following design guides for dimensioning specifications and ordering numbers for filters and brake resistors:

- *VLT® Brake Resistor MCE 101 Design Guide.*
- *VLT® Advanced Harmonic Filters AHF 005/AHF 010 Design Guide.*
- *Output Filters Design Guide.*

## 13.4 Spare Parts

Consult the VLT® shop or the Drive Configurator ([www.danfoss.com/drives](http://www.danfoss.com/drives)) for the spare parts that are available for your application.

## 14 Appendix

### 14.1 Abbreviations and Symbols

60° AVM	60° asynchronous vector modulation
A	Ampere/AMP
AC	Alternating current
AD	Air discharge
AEO	Automatic energy optimization
AI	Analog input
AIC	Ampere interrupting current
AMA	Automatic motor adaptation
AWG	American wire gauge
°C	Degrees Celsius
CB	Circuit breaker
CD	Constant discharge
CDM	Complete drive module: The drive, feeding section, and auxiliaries
CE	European conformity (European safety standards)
CM	Common mode
CT	Constant torque
DC	Direct current
DI	Digital input
DM	Differential mode
D-TYPE	Drive dependent
EMC	Electromagnetic compatibility
EMF	Electromotive force
ETR	Electronic thermal relay
°F	Degrees Fahrenheit
f <sub>JOG</sub>	Motor frequency when jog function is activated
f <sub>M</sub>	Motor frequency
f <sub>MAX</sub>	Maximum output frequency that the drive applies on its output
f <sub>MIN</sub>	Minimum motor frequency from the drive
f <sub>M,N</sub>	Nominal motor frequency
FC	Frequency converter (drive)
HIPERFACE®	HIPERFACE® is a registered trademark by Stegmann
HO	High overload
Hp	Horse power
HTL	HTL encoder (10–30 V) pulses - High-voltage transistor logic
Hz	Hertz
I <sub>INV</sub>	Rated inverter output current
I <sub>LIM</sub>	Current limit
I <sub>M,N</sub>	Nominal motor current
I <sub>VLT,MAX</sub>	Maximum output current
I <sub>VLT,N</sub>	Rated output current supplied by the drive
kHz	Kilohertz
LCP	Local control panel
Lsb	Least significant bit
m	Meter

mA	Milliamperere
MCM	Mille circular mil
MCT	Motion control tool
mH	Inductance in milli Henry
mm	Millimeter
ms	Millisecond
Msb	Most significant bit
η <sub>VLT</sub>	Efficiency of the drive defined as ratio between power output and power input
nF	Capacitance in nano Farad
NLCP	Numerical local control panel
Nm	Newton meter
NO	Normal overload
n <sub>s</sub>	Synchronous motor speed
Online/ Offline Parameters	Changes to online parameters are activated immediately after the data value is changed
P <sub>br,cont.</sub>	Rated power of the brake resistor (average power during continuous braking)
PCB	Printed circuit board
PCD	Process data
PDS	Power drive system: CDM and a motor
PELV	Protective extra low voltage
P <sub>m</sub>	Drive nominal output power as high overload (HO)
P <sub>M,N</sub>	Nominal motor power
PM motor	Permanent magnet motor
Process PID	PID (proportional integrated differential) regulator that maintains the speed, pressure, temperature, and so on
R <sub>br,nom</sub>	Nominal resistor value that ensures a brake power on the motor shaft of 150/160% for 1 minute
RCD	Residual current device
Regen	Regenerative terminals
R <sub>min</sub>	Minimum allowed brake resistor value by the drive
RMS	Root average square
RPM	Revolutions per minute
R <sub>rec</sub>	Recommended brake resistor resistance of Danfoss brake resistors
s	Second
SCCR	Short-circuit current rating
SFAVM	Stator flux-oriented asynchronous vector modulation
STW	Status word
SMPS	Switch mode power supply
THD	Total harmonic distortion
T <sub>LIM</sub>	Torque limit
TTL	TTL encoder (5 V) pulses - transistor logic
U <sub>M,N</sub>	Nominal motor voltage

UL	Underwriters Laboratories (US organization for the safety certification)
V	Volts
VT	Variable torque
VVC+	Voltage vector control plus

Table 14.1 Abbreviations and Symbols

## 14.2 Definitions

### Brake resistor

The brake resistor is a module capable of absorbing the brake power generated in regenerative braking. This regenerative brake power increases the DC-link voltage and a brake chopper ensures that the power is transmitted to the brake resistor.

### Break-away torque

$$n_s = \frac{2 \times par. 1 - 23 \times 60 s}{par. 1 - 39}$$

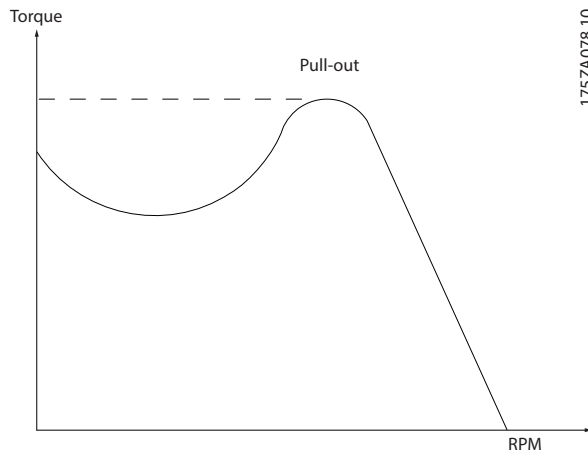

Illustration 14.1 Break-away Torque Chart

### Coast

The motor shaft is in free mode. No torque on the motor.

### CT characteristics

Constant torque characteristics used for all applications such as conveyor belts, displacement pumps, and cranes.

### Initializing

If initializing is carried out (*parameter 14-22 Operation Mode*), the drive returns to the default setting.

### Intermittent duty cycle

An intermittent duty rating refers to a sequence of duty cycles. Each cycle consists of an on-load and an off-load period. The operation can be either periodic duty or non-periodic duty.

### Power factor

The true power factor (lambda) takes all the harmonics into consideration and is always smaller than the power factor (cos phi) that only considers the 1<sup>st</sup> harmonics of current and voltage.

$$\cos\phi = \frac{P \text{ (kW)}}{P \text{ (kVA)}} = \frac{U\lambda \times I\lambda \times \cos\phi}{U\lambda \times I\lambda}$$

Cos phi is also known as displacement power factor.

Both lambda and cos phi are stated for Danfoss VLT® drives in *chapter 7.3 Mains Supply*.

The power factor indicates to which extent the drive imposes a load on the mains supply.

The lower the power factor, the higher the I<sub>RMS</sub> for the same kW performance.

In addition, a high-power factor indicates that the harmonic currents are low.

All Danfoss drives have built-in DC coils in the DC link to have a high-power factor and reduce the THD on the main supply.

### Pulse input/incremental encoder

An external digital sensor used for feedback information of motor speed and direction. Encoders are used for high-speed accuracy feedback and in high dynamic applications.

### Set-up

Save parameter settings in 4 set-ups. Change between the 4 parameter set-ups and edit 1 set-up while another set-up is active.

### Slip compensation

The drive compensates for the motor slip by giving the frequency a supplement that follows the measured motor load, keeping the motor speed almost constant.

### Smart logic Control (SLC)

The SLC is a sequence of user-defined actions executed when the associated user-defined events are evaluated as true by the SLC. (*Parameter group 13-\*\* Smart Logic*).

### FC Standard bus

Includes RS485 bus with FC protocol or MC protocol. See *parameter 8-30 Protocol*.

### Thermistor

A temperature-dependent resistor placed where the temperature is to be monitored (drive or motor).

### Trip

A state entered in fault situations, such as when the drive is subject to an overtemperature or when it protects the motor, process, or mechanism. Restart is prevented until the cause of the fault has disappeared and the trip state is canceled.

### Trip lock

A state entered in fault situations when the drive is protecting itself and requires physical intervention. A locked trip can only be canceled by cutting off mains, removing the cause of the fault, and reconnecting the drive. Restart is prevented until the trip state is canceled by activating reset.

### VT characteristics

Variable torque characteristics for pumps and fans.

### 14.3 RS485 Installation and Set-up

RS485 is a 2-wire bus interface compatible with multi-drop network topology. Nodes can be connected as a bus, or via drop cables from a common trunk line. A total of 32 nodes can be connected to 1 network segment.

Repeaters divide network segments. Note each repeater function as a node within the segment in which it is installed. Each node connected within a given network must have a unique node address, across all segments. Terminate each segment at both ends, using either the termination switch (S801) of the drives or a biased termination resistor network. Always use shielded twisted pair (STP) cable for bus cabling, and always follow good common installation practice.

Low-impedance ground connection of the shield at every node is important, including at high frequencies. Thus, connect a large surface of the shield to ground, for example, with a cable clamp or a conductive cable gland. If necessary, apply potential-equalizing cables to maintain the same ground potential throughout the network, particularly in installations with long cables.

To prevent impedance mismatch, always use the same type of cable throughout the entire network. When connecting a motor to the drive, always use shielded motor cable.

To avoid potential equalizing currents in the shield, ground the cable shield via terminal 61, which is connected to the frame via an RC-link.

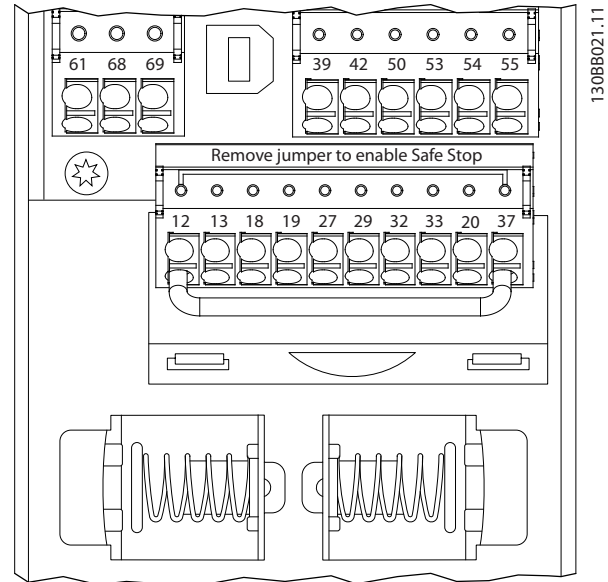

Illustration 14.3 Control Card Terminals

Cable	Shielded twisted pair (STP)
Impedance	120 Ω
Cable length	Maximum 1200 m (3937 ft), including drop lines. Maximum 500 m (1640.5 ft) station-to-station

Table 14.2 Motor Cable

One or more drives can be connected to a control (or master) using the RS485 standardized interface. Terminal 68 is connected to the P signal (TX+, RX+), while terminal 69 is connected to the N signal (TX-, RX-). See illustrations in *chapter 10.16 EMC-compliant Installation*.

If more than 1 drive is connected to a master, use parallel connections.

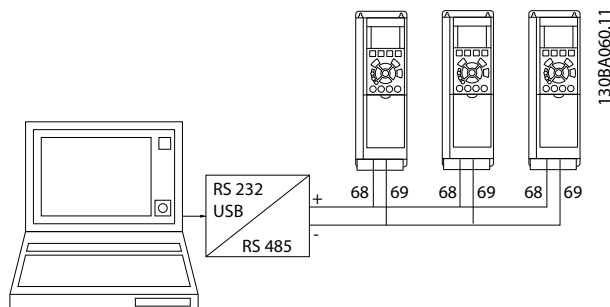

Illustration 14.2 Parallel Connections

The RS485 bus must be terminated by using a resistor network at both ends. For this purpose, set switch S801 on the control card to "ON".

For more information, see *chapter 10.2 Wiring Schematic*.

Communication protocol must be set to *parameter 8-30 Protocol*.

### 14.3.1 EMC Precautions

To achieve interference-free operation of the RS485 network, the following EMC precautions are recommended.

Relevant national and local regulations, regarding protective ground connection, for example, must be observed. The RS485 communication cable must be kept away from motor and brake resistor cables to avoid coupling of high-frequency noise from one cable to another. Normally a distance of 200 mm (8 in) is sufficient. However, in situations where cables run in parallel over long distances, keeping the greatest possible distance between cables is recommended. When crossing is unavoidable, the RS485 cable must cross motor and brake resistor cables at an angle of 90°.

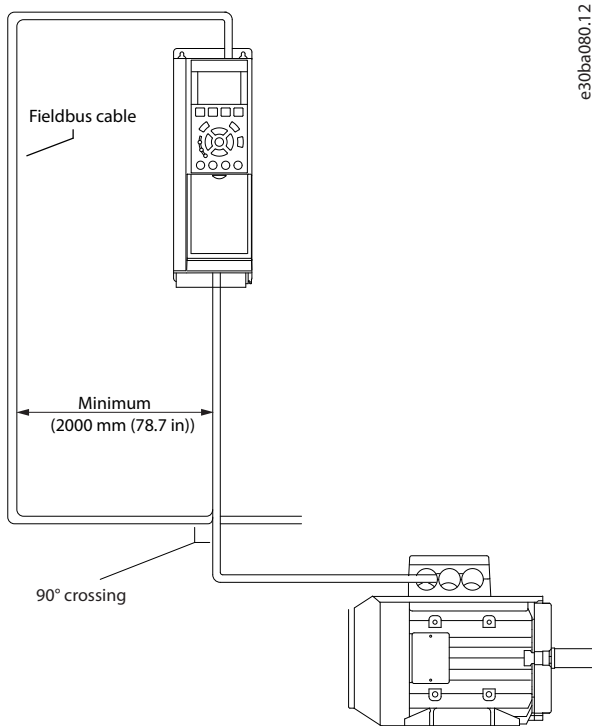

Illustration 14.4 EMC Precautions

## 14.4 RS485: FC Protocol Overview

### 14.4.1 FC Protocol Overview

The FC protocol, also referred to as FC bus or standard bus, is the Danfoss standard fieldbus. It defines an access technique according to the master/slave principle for communications via a field bus.

One master and a maximum of 126 slaves can be connected to the bus. The master selects the individual slaves via an address character in the telegram. A slave itself can never transmit without first being requested to do so, and direct message transfer between the individual

slaves is not possible. Communications occur in the half-duplex mode.

The master function cannot be transferred to another node (single-master system).

The physical layer is RS485, thus utilizing the RS485 port built into the drive. The FC protocol supports different telegram formats:

- A short format of 8 bytes for process data.
- A long format of 16 bytes that also includes a parameter channel.
- A format used for texts.

### 14.4.2 Drive Set-up

Set the following parameters to enable the FC protocol for the drive.

Parameter number	Setting
Parameter 8-30 Protocol	FC
Parameter 8-31 Address	1–126
Parameter 8-32 FC Port Baud Rate	2400–115200
Parameter 8-33 Parity / Stop Bits	Even parity, 1 stop bit (default)

Table 14.3 FC Protocol Parameters

## 14.5 RS485: FC Protocol Telegram Structure

### 14.5.1 Content of a Character (Byte)

Each character transferred begins with a start bit. Then 8 data bits are transferred, each corresponding to a byte. Each character is secured via a parity bit. This bit is set at 1" when it reaches parity. Parity is when there is an equal number of 1 characters in the 8 data bits and the parity bit in total. A stop bit completes a character, thus consisting of 11 bits in all.

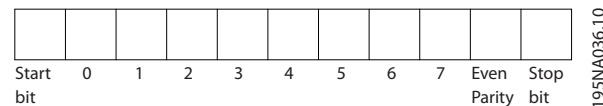

Illustration 14.5 Character (Byte)

### 14.5.2 Telegram Structure

Each telegram has the following structure:

- Start character (STX)=02 hex.
- A byte denoting the telegram length (LGE).
- A byte denoting the drive address (ADR).

A number of data bytes (variable, depending on the type of telegram) follows.

A data control byte (BCC) completes the telegram.



Illustration 14.6 Telegram Structure

### 14.5.3 Telegram Length (LGE)

The telegram length is the number of data bytes plus the address byte ADR and the data control byte BCC.

- The length of telegrams with 4 data bytes is  $LGE=4+1+1=6$  bytes.
- The length of telegrams with 12 data bytes is  $LGE=12+1+1=14$  bytes.
- The length of telegrams containing texts is  $10^1+n$  bytes.

1) The 10 represents the fixed characters, while the n is variable (depending on the length of the text).

### 14.5.4 Drive Address (ADR)

Two different address formats are used.

The address range of the drive is either 1–31 or 1–126.

- Address format 1–31
  - Bit 7=0 (address format 1–31 active).
  - Bit 6 is not used.
  - Bit 5=1: Broadcast, address bits (0–4) are not used.
  - Bit 5=0: No broadcast.
  - Bit 0–4=drive address 1–31.
- Address format 1–126
  - Bit 7=1 (address format 1–126 active).
  - Bit 0–6=drive address 1–126.
  - Bit 0–6=0 broadcast.

The slave returns the address byte unchanged to the master in the response telegram.

### 14.5.5 Data Control Byte (BCC)

The checksum is calculated as an XOR-function. Before the first byte in the telegram is received, the calculated checksum is 0.

### 14.5.6 Data Field

The structure of data blocks depends on the type of telegram. There are 3 types, and the type applies for both control telegrams (master⇒slave) and response telegrams (slave⇒master).

The 3 types of telegram are:

#### Process block (PCD)

The PCD is made up of a data block of 4 bytes (2 words) and contains:

- Control word and reference value (from master-to-slave).
- Status word and present output frequency (from slave-to-master).



130BA269.10

Illustration 14.7 PCD

#### Parameter block

The parameter block is used to transfer parameters between master and slave. The data block is made up of 12 bytes (6 words) and also contains the process block.

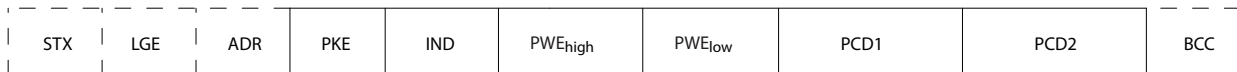

130BA271.10

Illustration 14.8 Parameter Block

#### Text block

The text block is used to read or write texts via the data block.

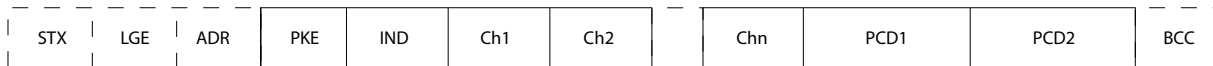

130BA270.10

Illustration 14.9 Text Block

### 14.5.7 PKE Field

The PKE field contains 2 sub fields:

- Parameter command and response AK.
- Parameter number PNU.

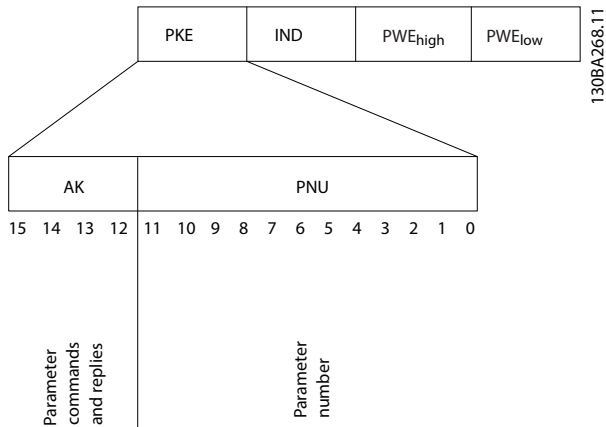

Illustration 14.10 PKE Field

Bits number 12–15 transfer parameter commands from master-to-slave and return processed slave responses to the master.

Bit number				Parameter command
15	14	13	12	
0	0	0	0	No command.
0	0	0	1	Read parameter value.
0	0	1	0	Write parameter value in RAM (word).
0	0	1	1	Write parameter value in RAM (double word).
1	1	0	1	Write parameter value in RAM and EEPROM (double word).
1	1	1	0	Write parameter value in RAM and EEPROM (word).
1	1	1	1	Read/write text.

Table 14.4 Parameter Commands Master⇒Slave

Bit number				Response
15	14	13	12	
0	0	0	0	No response.
0	0	0	1	Parameter value transferred (word).
0	0	1	0	Parameter value transferred (double word).
0	1	1	1	Command cannot be performed.
1	1	1	1	Text transferred.

Table 14.5 Response Slave⇒Master

If the command cannot be performed, the slave sends this response:

0111 Command cannot be performed

- and issues the following fault report in the parameter value (PWE):

PWE low (hex)	Fault report
0	The parameter number used does not exist.
1	There is no write access to the defined parameter.
2	Data value exceeds the parameter limits.
3	The sub-index used does not exist.
4	The parameter is not the array type.
5	The data type does not match the defined parameter.
11	Data change in the defined parameter is not possible in the present mode of the drive. Certain parameters can only be changed when the motor is turned off.
82	There is no bus access to the defined parameter.
83	Data change is not possible because factory set-up is selected.

Table 14.6 Fault Report

### 14.5.8 Parameter Number (PNU)

Bits number 0–11 transfer parameter numbers. The function of the relevant parameter is defined in the parameter description in the *programming guide*.

### 14.5.9 Index (IND)

The index is used together with the parameter number to read/write-access parameters with an index, for example, *parameter 15-30 Alarm Log: Error Code*. The index consists of a low byte and a high byte.

Only the low byte is used as an index.

### 14.5.10 Parameter Value (PWE)

The parameter value block consists of 2 words (4 bytes), and the value depends on the defined command (AK). The master prompts for a parameter value when the PWE block contains no value. To change a parameter value (write), write the new value in the PWE block and send from the master to the slave.

When a slave responds to a parameter request (read command), the present parameter value in the PWE block is transferred and returned to the master. If a parameter contains not a numerical value but several data options, for example, *parameter 0-01 Language [0] English*, and *[4] Danish*, select the data value by entering the value in the



PWE block. Serial communication is only capable of reading parameters containing data type 9 (text string).

Parameter 15-40 FC Type to parameter 15-53 Power Card Serial Number contain data type 9.

For example, read the unit size and mains voltage range in parameter 15-40 FC Type. When a text string is transferred (read), the length of the telegram is variable, and the texts are of different lengths. The telegram length is defined in the 2<sup>nd</sup> byte of the telegram, LGE. When using text transfer, the index character indicates whether it is a read or a write command.

To read a text via the PWE block, set the parameter command (AK) to F hex. The index character high-byte must be 4.

Some parameters contain text that can be written via the fieldbus. To write a text via the PWE block, set the parameter command (AK) to F hex. The index characters high-byte must be 5.

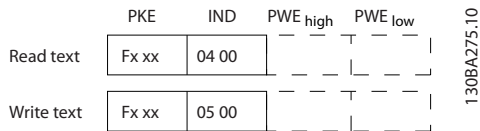

Illustration 14.11 PWE

### 14.5.11 Data Types Supported

Unsigned means that there is no operational sign in the telegram.

Data types	Description
3	Integer 16
4	Integer 32
5	Unsigned 8
6	Unsigned 16
7	Unsigned 32
9	Text string
10	Byte string
13	Time difference
33	Reserved
35	Bit sequence

Table 14.7 Data Types Supported

### 14.5.12 Conversion

The various attributes of each parameter are shown in the section factory settings. Parameter values are transferred as whole numbers only. Conversion factors are therefore used to transfer decimals.

Parameter 4-12 Motor Speed Low Limit [Hz] has a conversion factor of 0.1.

To preset the minimum frequency to 10 Hz, transfer the value 100. A conversion factor of 0.1 means that the value transferred is multiplied by 0.1. The value 100 is thus perceived as 10.0.

Examples:

- 0 s⇒conversion index 0
- 0.00 s⇒conversion index -2
- 0 M/S⇒conversion index -3
- 0.00 M/S⇒conversion index -5

Conversion index	Conversion factor
100	
75	
74	
67	
6	1000000
5	100000
4	10000
3	1000
2	100
1	10
0	1
-1	0.1
-2	0.01
-3	0.001
-4	0.0001
-5	0.00001
-6	0.000001
-7	0.0000001

Table 14.8 Conversion Table

### 14.5.13 Process Words (PCD)

The block of process words is divided into 2 blocks of 16 bits, which always occur in the defined sequence.

PCD 1	PCD 2
Control telegram (master⇒slave) control word	Reference-value
Control telegram (slave⇒master) status word	Present output frequency

Table 14.9 PCD Sequence

## 14.6 RS485: FC Protocol Parameter Examples

### 14.6.1 Writing a Parameter Value

Change parameter 4-14 Motor Speed High Limit [Hz] to 100 Hz.

Write the data in EEPROM.

PKE=E19E hex - Write single word in *parameter 4-14 Motor Speed High Limit [Hz]*.  
 IND=0000 hex  
 PWE<sub>high</sub>=0000 hex  
 PWE<sub>low</sub>=03E8 hex - Data value 1000, corresponding to 100 Hz, see *chapter 14.5.12 Conversion*.

E19E	H	0000	H	0000	H	03E8	H
PKE		IND		PWE <sub>high</sub>		PWE <sub>low</sub>	

130BA092.10

Illustration 14.12 Telegram

**NOTICE**

*Parameter 4-14 Motor Speed High Limit [Hz]* is a single word, and the parameter command for write in EEPROM is E. Parameter number *parameter 4-14 Motor Speed High Limit [Hz]* is 19E in hexadecimal.

119E	H	0000	H	0000	H	03E8	H
PKE		IND		PWE <sub>high</sub>		PWE <sub>low</sub>	

130BA093.10

Illustration 14.13 Response from Master-to-Slave

14.6.2 Reading a Parameter Value

Read the value in *parameter 3-41 Ramp 1 Ramp Up Time*.

PKE=1155 Hex - Read parameter value in *parameter 3-41 Ramp 1 Ramp Up Time*  
 IND=0000 hex  
 PWE<sub>high</sub>=0000 hex  
 PWE<sub>low</sub>=0000 hex

1155	H	0000	H	0000	H	0000	H
PKE		IND		PWE <sub>high</sub>		PWE <sub>low</sub>	

130BA094.10

Illustration 14.14 Parameter Value

If the value in *parameter 3-41 Ramp 1 Ramp Up Time* is 10 s, the response from the slave to the master is:

1155	H	0000	H	0000	H	03E8	H
PKE		IND		PWE <sub>high</sub>		PWE <sub>low</sub>	

130BA267.10

Illustration 14.15 Response from Slave-to-Master

3E8 hex corresponds to 1000 decimal. The conversion index for *parameter 3-41 Ramp 1 Ramp Up Time* is -2.

*Parameter 3-41 Ramp 1 Ramp Up Time* is of the type *Unsigned 32*.

14.7 RS485: Modbus RTU Overview

14.7.1 Assumptions

Danfoss assumes that the installed controller supports the interfaces in this manual, and strictly observes all requirements and limitations stipulated in the controller and drive.

14.7.2 Prerequisite Knowledge

The Modbus RTU (Remote Terminal Unit) is designed to communicate with any controller that supports the interfaces defined in this manual. It is assumed that the reader has full knowledge of the capabilities and limitations of the controller.

14.7.3 Modbus RTU Overview

Regardless of the type of physical communication networks, the Modbus RTU Overview describes the process a controller uses to request access to another device. This process includes how the Modbus RTU responds to requests from another device, and how errors are detected and reported. It also establishes a common format for the layout and contents of message fields.

During communications over a Modbus RTU network, the protocol determines:

- How each controller learns its device address.
- Recognizes a message addressed to it.
- Determines which actions to take.
- Extracts any data or other information contained in the message.

If a reply is required, the controller constructs the reply message and sends it.

Controllers communicate using a master-slave technique in which only 1 device (the master) can initiate transactions (called queries). The other devices (slaves) respond by supplying the requested data to the master, or by responding to the query.

The master can address individual slaves, or can initiate a broadcast message to all slaves. Slaves return a message, called a response, to queries that are addressed to them individually. No responses are returned to broadcast queries from the master. The Modbus RTU protocol establishes the format for the master query by placing into it the device (or broadcast) address, a function code defining the requested action, any data to send, and an error-checking field. The slave response message is also constructed using Modbus protocol. It contains fields confirming the action taken, any data to return, and an error-checking field. If an error occurs in receipt of the

message, or if the slave is unable to perform the requested action, the slave constructs an error message which it sends in response, or a timeout occurs.

### 14.7.4 Drive with Modbus RTU

The drive communicates in Modbus RTU format over the built-in RS485 interface. Modbus RTU provides access to the control word and bus reference of the drive.

The control word allows the Modbus master to control several important functions of the drive:

- Start
- Stop of the drive in various ways:
  - Coast stop
  - Quick stop
  - DC brake stop
  - Normal (ramp) stop
- Reset after a fault trip.
- Run at various preset speeds.
- Run in reverse.
- Change the active set-up.
- Control the built-in relay of the drive.

The bus reference is commonly used for speed control. It is also possible to access the parameters, read their values, and, where possible, write values to them, allowing a range of control options, including controlling the setpoint of the drive when its internal PI controller is used.

### 14.7.5 Drive with Modbus RTU

To enable Modbus RTU on the drive, set the following parameters:

Parameter	Setting
Parameter 8-30 Protocol	Modbus RTU
Parameter 8-31 Address	1-247
Parameter 8-32 Baud Rate	2400-115200
Parameter 8-33 Parity / Stop Bits	Even parity, 1 stop bit (default)

### 14.7.6 Drive with Modbus RTU

The controllers are set up to communicate on the Modbus network using RTU mode, with each byte in a message containing 2 4-bit hexadecimal characters. The format for each byte is shown in *Table 14.10*.

Start bit	Data byte						Stop/parity	Stop
0	0	0	0	0	0	0	0	

Table 14.10 Example Format

Coding system	8-bit binary, hexadecimal 0-9, A-F. 2 hexadecimal characters contained in each 8-bit field of the message.
Bits per byte	1 start bit. 8 data bits, least significant bit sent first. 1 bit for even/odd parity; no bit for no parity. 1 stop bit if parity is used; 2 bits if no parity.
Error check field	CRC (cyclical redundancy check)

Table 14.11 Bit Detail

## 14.8 RS485: Modbus RTU Telegram Structure

### 14.8.1 Modbus RTU Telegram Structure

The transmitting device places a Modbus RTU message into a frame with a known beginning and ending point. Receiving devices are able to begin at the start of the message, read the address portion, determine which device is addressed (or all devices, if the message is broadcast), and to recognize when the message is completed. Partial messages are detected and errors set as a result. Characters for transmission must be in hexadecimal 00-FF format in each field. The drive continuously monitors the network bus, also during silent intervals. When the first field (the address field) is received, each drive or device decodes it to determine which device is being addressed. Modbus RTU messages addressed to 0 are broadcast messages. No response is allowed for broadcast messages. A typical message frame is shown in *Table 14.12*.

Start	Address	Function	Data	CRC check	End
T1-T2-T3-T4	8 bits	8 bits	N x 8 bits	16 bits	T1-T2-T3-T4

Table 14.12 Typical Modbus RTU Telegram Structure

### 14.8.2 Start/Stop Field

Messages start with a silent period of at least 3.5 character intervals, implemented as a multiple of character intervals at the selected network baud rate (shown as start T1-T2-T3-T4). The first transmitted field is the device address. Following the last transmitted character, a similar period of at least 3.5 character intervals marks the end of the message. A new message can begin after this period. The entire message frame must be transmitted as a continuous stream. If a silent period of more than 1.5 character intervals occurs before completion of the frame, the receiving device flushes the incomplete message and assumes that the next byte is the address field of a new message. Similarly, if a new message begins before 3.5

character intervals after a previous message, the receiving device considers it a continuation of the previous message, causing a timeout (no response from the slave), since the value in the final CRC (cyclical redundancy check) field is not valid for the combined messages.

### 14.8.3 Address Field

The address field of a message frame contains 8 bits. Valid slave device addresses are in the range of 0–247 decimal. The individual slave devices are assigned addresses in the range of 1–247 (0 is reserved for broadcast mode, which all slaves recognize). A master addresses a slave by placing the slave address in the address field of the message. When the slave sends its response, it places its own address in this address field to let the master know which slave is responding.

### 14.8.4 Function Field

The function field of a message frame contains 8 bits. Valid codes are in the range of 1–FF. Function fields are used to send messages between master and slave. When a message is sent from a master to a slave device, the function code field tells the slave what action to perform. When the slave responds to the master, it uses the function code field to indicate either a normal (error-free) response, or that an error has occurred (called an exception response). For a normal response, the slave simply echoes the original function code. For an exception response, the slave returns a code that is equivalent to the original function code with its most significant bit set to logic 1. In addition, the slave places a unique code into the data field of the response message. This code tells the master what error occurred, or the reason for the exception. See *chapter 14.9.1 Function Codes Supported by Modbus RTU*.

### 14.8.5 Data Field

The data field is constructed using sets of 2 hexadecimal digits, in the range of 00–FF hexadecimal. These sequences are made up of 1 RTU character. The data field of messages sent from a master-to-slave device contains more information, which the slave must use to do what is defined by the function code. This information can include items such as coil or register addresses, the quantity of items, and the count of actual data bytes in the field.

### 14.8.6 CRC Check Field

Messages include an error-checking field, operating based on a CRC (cyclical redundancy check) method. The CRC field checks the contents of the entire message. It is applied regardless of any parity check method used for the individual characters of the message. The transmitting

device calculates the CRC value then appends the CRC as the last field in the message. The receiving device recalculates a CRC during receipt of the message and compares the calculated value to the actual value received in the CRC field. If the 2 values are unequal, a bus timeout results. The error-checking field contains a 16-bit binary value implemented as 2 8-bit bytes. After error-checking, the low-order byte of the field is appended first, followed by the high-order byte. The CRC high-order byte is the last byte sent in the message.

### 14.8.7 Coil Register Addressing

In Modbus, all data are organized in coils and holding registers. Coils hold a single bit, whereas holding registers hold a 2 byte word (16 bits). All data addresses in Modbus messages are referenced to 0. The first occurrence of a data item is addressed as item number 0. For example: The coil known as coil 1 in a programmable controller is addressed as coil 0000 in the data address field of a Modbus message. Coil 127 decimal is addressed as coil 007Ehex (126 decimal).

Holding register 40001 is addressed as register 0000 in the data address field of the message. The function code field already specifies a holding register operation. Therefore, the 4XXXX reference is implicit. Holding register 40108 is addressed as register 006Bhex (107 decimal).

Coil number	Description	Signal direction
1–16	Drive control word (see <i>Table 14.14</i> ).	Master-to-slave
17–32	Drive speed or setpoint reference range 0x0–0xFFFF (-200% ... ~200%).	Master-to-slave
33–48	Drive status word (see <i>Table 14.14</i> ).	Master-to-slave
49–64	Open-loop mode: Drive output frequency. Closed-loop mode: Drive feedback signal.	Slave-to-master
65	Parameter write control (master-to-slave).	Master-to-slave
	0 = Parameter changes are written to the RAM of the drive.	
	1 =Parameter changes are written to the RAM and EEPROM of the drive.	
66–65536	Reserved.	

**Table 14.13 Coils and Holding Registers**

Coil	0	1
01	Preset reference LSB	
02	Preset reference MSB	
03	DC brake	No DC brake
04	Coast stop	No coast stop
05	Quick stop	No quick stop
06	Freeze frequency	No freeze frequency
07	Ramp stop	Start
08	No reset	Reset
09	No jog	Jog
10	Ramp 1	Ramp 2
11	Data not valid	Data valid
12	Relay 1 off	Relay 1 on
13	Relay 2 off	Relay 2 on
14	Set up LSB	
15	Set up MSB	
16	No reversing	Reversing

Coil	0	1
33	Control not ready	Control ready
34	Drive not ready	Drive ready
35	Coasting stop	Safety closed
36	No alarm	Alarm
37	Not used	Not used
38	Not used	Not used
39	Not used	Not used
40	No warning	Warning
41	Not at reference	At reference
42	Hand mode	Auto mode
43	Out of frequency range	In frequency range
44	Stopped	Running
45	Not used	Not used
46	No voltage warning	Voltage warning
47	Not in current limit	Current limit
48	No thermal warning	Thermal warning

**Table 14.14 Drive Control Word (FC Profile)**

Register number	Description
00001–00006	Reserved.
00007	Last fault code from an FC data object interface.
00008	Reserved.
00009	Parameter index <sup>1)</sup> .
00010–00990	000 parameter group (parameters 001–099).
01000–01990	100 parameter group (parameters 100–199).
02000–02990	200 parameter group (parameters 200–299).
03000–03990	300 parameter group (parameters 300–399).
04000–04990	400 parameter group (parameters 400–499).
...	...
49000–49990	4900 parameter group (parameters 4900–4999).
50000	Input data: Drive control word register (CTW).
50010	Input data: Bus reference register (REF).
...	...
50200	Output data: Drive status word register (STW).
50210	Output data: Drive main actual value register (MAV).

**Table 14.15 Drive Status Word (FC Profile)**

**Table 14.16 Holding Registers**

1) Used to specify the index number used when accessing an indexed parameter.

## 14.9 RS485: Modbus RTU Message Function Codes

### 14.9.1 Function Codes Supported by Modbus RTU

Modbus RTU supports use of the function codes in *Table 14.17* in the function field of a message.

Function	Function code
Read coils	1 hex
Read holding registers	3 hex
Write single coil	5 hex
Write single register	6 hex
Write multiple coils	F hex
Write multiple registers	10 hex
Get comm. event counter	B hex
Report slave ID	11 hex

Table 14.17 Function Codes

Function	Function code	Sub-function code	Sub-function
Diagnostics	8	1	Restart communication.
		2	Return diagnostic register.
		10	Clear counters and diagnostic register.
		11	Return bus message count.
		12	Return bus communication error count.
		13	Return bus exception error count.
		14	Return slave message count.

Table 14.18 Function Codes

### 14.9.2 Modbus Exception Codes

For a full explanation of the structure of an exception code response, refer to *chapter 14.8 RS485: Modbus RTU Telegram Structure*.

Code	Name	Meaning
1	Illegal function	The function code received in the query is not an allowable action for the server (or slave). This code can be because the function code is only applicable to newer devices, and was not implemented in the unit selected. It could also indicate that the server (or slave) is in the wrong state to process a request of this type, for example because it is not configured and is being asked to return register values.

Code	Name	Meaning
2	Illegal data address	The data address received in the query is not an allowable address for the server (or slave). More specifically, the combination of reference number and transfer length is invalid. For a controller with 100 registers, a request with offset 96 and length 4 would succeed, a request with offset 96 and length 5 generates exception 02.
3	Illegal data value	A value contained in the query data field is not an allowable value for server (or slave). This code indicates a fault in the structure of the remainder of a complex request, such as that the implied length is incorrect. It specifically does NOT mean that a data item submitted for storage in a register has a value outside the expectation of the application program, since the Modbus protocol is unaware of the significance of any particular value of any particular register.
4	Slave device failure	An unrecoverable error occurred while the server (or slave) was attempting to perform the requested action.

Table 14.19 Modbus Exception Codes

## 14.10 RS485: Modbus RTU Parameters

### 14.10.1 Parameter Handling

The PNU (parameter number) is translated from the register address contained in the Modbus read or write message. The parameter number is translated to Modbus as (10xparameter number) DECIMAL.

### 14.10.2 Storage of Data

The coil 65 decimal determines whether data written to the drive is stored in EEPROM and RAM (coil 65=1) or only in RAM (coil 65=0).

### 14.10.3 IND

The array index is set in holding register 9 and used when accessing array parameters.

### 14.10.4 Text Blocks

Parameters stored as text strings are accessed in the same way as the other parameters. The maximum text block size is 20 characters. If a read request for a parameter is for more characters than the parameter stores, the response is truncated. If the read request for a parameter is for fewer characters than the parameter stores, the response is space filled.

### 14.10.5 Conversion Factor

Since a parameter value can only be transferred as a whole number, a conversion factor must be used to transfer decimals. See *chapter 14.6 RS485: FC Protocol Parameter Examples*.

### 14.10.6 Parameter Values

#### Standard data types

Standard data types are int16, int32, uint8, uint16, and uint32. They are stored as 4x registers (40001–4FFFF). The parameters are read using function 03 hex read holding registers. Parameters are written using the function 6 hex preset single register for 1 register (16 bits), and the function 10 hex preset multiple registers for 2 registers (32 bits). Readable sizes range from 1 register (16 bits) up to 10 registers (20 characters).

#### Non-standard data types

Non-standard data types are text strings and are stored as 4x registers (40001–4FFFF). The parameters are read using function 03 hex Read holding registers and written using function 10 hex Preset multiple registers. Readable sizes range from 1 register (2 characters) up to 10 registers (20 characters).

## 14.11 RS485: FC Control Profile

### 14.11.1 Control Word According to FC Profile

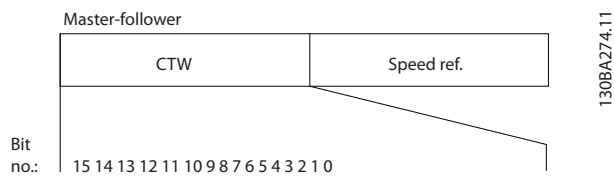

Illustration 14.16 CW Master-to-Slave

Bit	Bit value=0	Bit value=1
00	Reference value	External selection lsb
01	Reference value	External selection msb
02	DC brake	Ramp
03	Coasting	No coasting
04	Quick stop	Ramp
05	Hold output frequency	Use ramp
06	Ramp stop	Start
07	No function	Reset
08	No function	Jog
09	Ramp 1	Ramp 2
10	Data invalid	Data valid
11	No function	Relay 01 active
12	No function	Relay 02 active
13	Parameter set-up	Selection lsb
14	Parameter set-up	Selection msb
15	No function	Reverse

#### Explanation of the control bits

##### Bits 00/01

Bits 00 and 01 are used to select between the 4 reference values, which are pre-programmed in *parameter 3-10 Preset Reference* according to *Table 14.20*.

Programmed reference value	Parameter	Bit 01	Bit 00
1	[0] <i>parameter 3-10 Preset Reference</i>	0	0
2	[1] <i>parameter 3-10 Preset Reference</i>	0	1
3	[2] <i>parameter 3-10 Preset Reference</i>	1	0
4	[3] <i>parameter 3-10 Preset Reference</i>	1	1

Table 14.20 Control Bits

#### NOTICE

Make a selection in *parameter 8-56 Preset Reference Select* to define how bit 00/01 gates with the corresponding function on the digital inputs.

##### Bit 02, DC brake

Bit 02=0 leads to DC braking and stop. Set braking current and duration in *parameter 2-01 DC Brake Current* and *parameter 2-02 DC Braking Time*.

Bit 02=1 leads to ramping.

**Bit 03, Coasting**

Bit 03=0: The drive immediately shuts off the output transistors and the motor coasts to a standstill.

Bit 03=1: The drive starts the motor if the other starting conditions are met.

Make a selection in *parameter 8-50 Coasting Select* to define how bit 03 gates with the corresponding function on a digital input.

**Bit 04, Quick stop**

Bit 04=0: Makes the motor speed ramp down to stop (set in *parameter 3-81 Quick Stop Ramp Time*).

**Bit 05, Hold output frequency**

Bit 05=0: The present output frequency (in Hz) freezes. Change the frozen output frequency only with the digital inputs found in *parameter 5-10 Terminal 18 Digital Input – parameter 5-15 Terminal 33 Digital Input*.

**NOTICE**

If freeze output is active, only the following conditions can stop the drive:

- Bit 03 Coasting stop.
- Bit 02 DC braking.
- Digital input (*parameter 5-10 Terminal 18 Digital Input – parameter 5-15 Terminal 33 Digital Input*) programmed to *DC braking, Coasting stop, or Reset and Coasting stop*.

**Bit 06, Ramp stop/start**

Bit 06=0: Causes a stop and makes the motor speed ramp down to stop via the selected ramp down parameter.

Bit 06=1: Allows the drive to start the motor if the other starting conditions are met.

Make a selection in *parameter 8-53 Start Select* to define how bit 06 Ramp stop/start gates with the corresponding function on a digital input.

**Bit 07, Reset**

Bit 07=0: No reset.

Bit 07=1: Resets a trip. Reset is activated on the leading edge of the signal, that is, when changing from logic 0 to logic 1.

**Bit 08, Jog**

Bit 08=1: The output frequency depends on *parameter 3-19 Jog Speed [RPM]*.

**Bit 09, Selection of ramp 1/2**

Bit 09=0: Ramp 1 is active (*parameter 3-41 Ramp 1 Ramp Up Time – parameter 3-42 Ramp 1 Ramp Down Time*).

Bit 09=1: Ramp 2 (*parameter 3-51 Ramp 2 Ramp Up Time – parameter 3-52 Ramp 2 Ramp Down Time*) is active.

**Bit 10, Data not valid/Data valid**

Tell the drive whether to use or ignore the control word.

Bit 10=0: The control word is ignored.

Bit 10=1: The control word is used. This function is relevant because the telegram always contains the control word regardless of the telegram type. Thus, it is possible to turn off the control word if not in use when updating or reading parameters.

**Bit 11, Relay 01**

Bit 11=0: Relay not activated.

Bit 11=1: Relay 01 activated if [36] Control word bit 11 is selected in *parameter 5-40 Function Relay*.

**Bit 12, Relay 04**

Bit 12=0: Relay 04 is not activated.

Bit 12=1: Relay 04 is activated if [37] Control word bit 12 is selected in *parameter 5-40 Function Relay*.

**Bit 13/14, Selection of set-up**

Use bits 13 and 14 to select from the 4 menu set-ups according to *Table 14.21*.

Set-up	Bit 14	Bit 13
1	0	0
2	0	1
3	1	0
4	1	1

Table 14.21 Selection of Set-Up

The function is only possible when [9] Multi Set-ups is selected in *parameter 0-10 Active Set-up*.

Make a selection in *parameter 8-55 Set-up Select* to define how bit 13/14 gates with the corresponding function on the digital inputs.

**Bit 15 Reverse**

Bit 15=0: No reversing.

Bit 15=1: Reversing. In the default setting, reversing is set to [0] Digital input in *parameter 8-54 Reversing Select*. Bit 15 causes reversing only when the following is selected:

- Serial communication
- Logic or
- Logic and

14.11.2 Status Word According to FC Profile

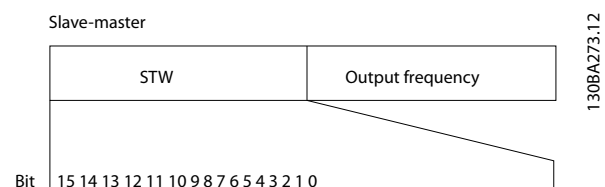

Illustration 14.17 STW Slave-to-Master



Bit	Bit=0	Bit=1
00	Control not ready	Control ready
01	Drive not ready	Drive ready
02	Coasting	Enable
03	No error	Trip
04	No error	Error (no trip)
05	Reserved	–
06	No error	Triplock
07	No warning	Warning
08	Speed≠reference	Speed=reference
09	Local operation	Bus control
10	Out of frequency limit	Frequency limit OK
11	No operation	In operation
12	Drive OK	Stopped, auto start
13	Voltage OK	Voltage exceeded
14	Torque OK	Torque exceeded
15	Timer OK	Timer exceeded

**Bit 00, Control not ready/ready**

Bit 00=0: The drive trips.

Bit 00=1: The drive controls are ready, but the power component does not necessarily receive any supply in the case of a 24 V external supply to the controls.

**Bit 01, Drive ready**

Bit 01=1: The drive is ready for operation but the coasting command is active via the digital inputs or via serial communication.

**Bit 02, Coasting stop**

Bit 02=0: The drive releases the motor.

Bit 02=1: The drive starts the motor with a start command.

**Bit 03, No error/trip**

Bit 03=0: The drive is not in fault mode.

Bit 03=1: The drive trips. To re-establish operation, press [Reset].

**Bit 04, No error/error (no trip)**

Bit 04=0: The drive is not in fault mode.

Bit 04=1: The drive shows an error but does not trip.

**Bit 05, Not used**

Bit 05 is not used in the status word.

**Bit 06, No error/triplock**

Bit 06=0: The drive is not in fault mode.

Bit 06=1: The drive is tripped and locked.

**Bit 07, No warning/warning**

Bit 07=0: There are no warnings.

Bit 07=1: A warning has occurred.

**Bit 08, Speed≠ reference/speed=reference**

Bit 08=0: The motor is running, but the present speed is different from the preset speed reference. For example, when the speed ramps up/down during start/stop.

Bit 08=1: The motor speed matches the preset speed reference.

**Bit 09, Local operation/bus control**

Bit 09=0: [Stop/reset] is activated on the control unit or [2] Local in *parameter 3-13 Reference Site* is selected. The drive cannot be controlled via serial communication.

Bit 09=1 It is possible to control the drive via the fieldbus/serial communication.

**Bit 10, Out of frequency limit**

Bit 10=0: The output frequency has reached the value in *parameter 4-11 Motor Speed Low Limit [RPM]* or *parameter 4-13 Motor Speed High Limit [RPM]*.

Bit 10=1: The output frequency is within the defined limits.

**Bit 11, No operation/in operation**

Bit 11=0: The motor is not running.

Bit 11=1: The drive has a start signal or the output frequency is greater than 0 Hz.

**Bit 12, Drive OK/stopped, autostart**

Bit 12=0: There is no temporary overtemperature on the inverter.

Bit 12=1: The inverter stops because of overtemperature but the unit does not trip and resumes operation once the overtemperature stops.

**Bit 13, Voltage OK/limit exceeded**

Bit 13=0: There are no voltage warnings.

Bit 13=1: The DC voltage in the DC link is too low or too high.

**Bit 14, Torque OK/limit exceeded**

Bit 14=0: The motor current is lower than the torque limit selected in *parameter 4-18 Current Limit*.

Bit 14=1: The torque limit in *parameter 4-18 Current Limit* is exceeded.

**Bit 15, Timer OK/limit exceeded**

Bit 15=0: The timers for motor thermal protection and thermal protection are not exceeded 100%.

Bit 15=1: One of the timers exceeds 100%.

If the connection between the InterBus option and the drive is lost, or an internal communication problem has occurred, all bits in the STW are set to 0.

### 14.11.3 Bus Speed Reference Value

Speed reference value is transmitted to the drive in a relative value in %. The value is transmitted in the form of a 16-bit word; in integers (0–32767) the value 16384 (4000 hex) corresponds to 100%. Negative figures are formatted with 2's complement. The actual output frequency (MAV) is scaled in the same way as the bus reference.

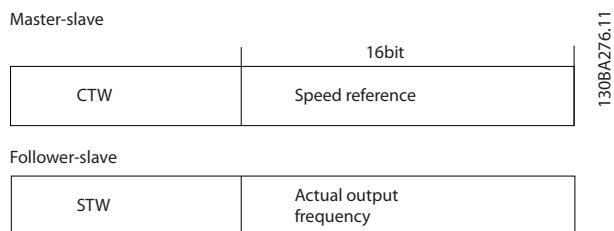

Illustration 14.18 Bus Speed Reference Value

The reference and MAV are scaled as shown in *Illustration 14.19*.

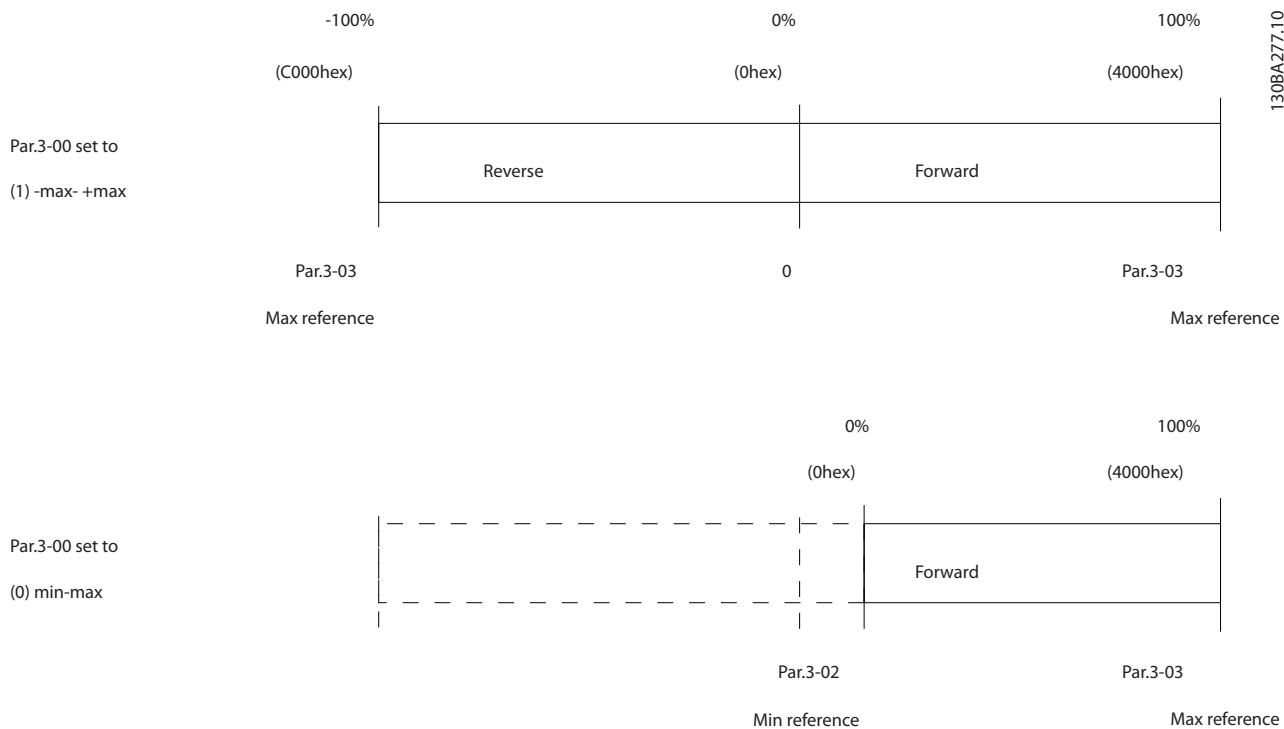

Illustration 14.19 Reference and MAV

#### 14.11.4 Control Word According to PROFdrive Profile (CTW)

The control word is used to send commands from a master to a slave.

Bit	Bit=0	Bit=1
00	OFF 1	ON 1
01	OFF 2	ON 2
02	OFF 3	ON 3
03	Coasting	No coasting
04	Quick stop	Ramp
05	Hold frequency output	Use ramp
06	Ramp stop	Start
07	No function	Reset
08	Jog 1 OFF	Jog 1 ON
09	Jog 2 OFF	Jog 2 ON
10	Data invalid	Data valid
11	No function	Slow down
12	No function	Catch up
13	Parameter set-up	Selection lsb
14	Parameter set-up	Selection msb
15	No function	Reverse

Table 14.22 Bit Values for Control Word, PROFdrive Profile

#### Explanation of the control bits

##### Bit 00, OFF 1/ON 1

Normal ramp stops using the ramp times of the actual selected ramp.

Bit 00=0 leads to the stop and activation of the output relay 1 or 2 if the output frequency is 0 Hz and if [31] Relay 123 has been selected in *parameter 5-40 Function Relay*. When bit 00=1, the drive is in State 1: Switching on inhibited.

##### Bit 01, OFF 2/ON 2

Coasting stop

When bit 01=0, a coasting stop and activation of the output relay 1 or 2 occurs if the output frequency is 0 Hz and if [31] Relay 123 has been selected in *parameter 5-40 Function Relay*.

When bit 01=1, the drive is in State 1: on inhibited. Refer to *Table 14.23*, at the end of this section.

##### Bit 02, OFF 3/ON 3

Quick stop using the ramp time of *parameter 3-81 Quick Stop Ramp Time*.

When bit 02=0, a quick stop and activation of the output relay 1 or 2 occurs if the output frequency is 0 Hz and if [31] Relay 123 has been selected in *parameter 5-40 Function Relay*.

When bit 02=1, the drive is in State 1: Switching on inhibited.

##### Bit 03, Coasting/No coasting

Coasting stop bit 03=0 leads to a stop.

When bit 03=1, the drive can start if the other start conditions are satisfied.

#### NOTICE

The selection in *parameter 8-50 Coasting Select* determines how bit 03 is linked with the corresponding function of the digital inputs.

##### Bit 04, Quick stop/Ramp

Quick stop using the ramp time of *parameter 3-81 Quick Stop Ramp Time*.

When bit 04=0, a quick stop occurs.

When bit 04=1, the drive can start if the other start conditions are satisfied.

#### NOTICE

The selection in *parameter 8-51 Quick Stop Select* determines how bit 04 is linked with the corresponding function of the digital inputs.

##### Bit 05, Hold frequency output/Use ramp

When bit 05=0, the current output frequency is being maintained even if the reference value is modified.

When bit 05=1, the drive can perform its regulating function again; operation occurs according to the respective reference value.

##### Bit 06, Ramp stop/Start

Normal ramp stop using the ramp times of the actual ramp as selected. In addition, activation of the output relay 01 or 04 if the output frequency is 0 Hz if [31] Relay 123 has been selected in *parameter 5-40 Function Relay*.

Bit 06=0 leads to a stop.

When bit 06=1, the drive can start if the other start conditions are fulfilled.

#### NOTICE

The selection in *parameter 8-53 Start Select* determines how bit 06 is linked with the corresponding function of the digital inputs.

##### Bit 07, No function/Reset

Reset after switching off.

Acknowledges event in fault buffer.

When bit 07=0, no reset occurs.

When there is a slope change of bit 07 to 1, a reset occurs after switching off.

##### Bit 08, Jog 1 OFF/ON

Activates the pre-programmed speed in *parameter 8-90 Bus Jog 1 Speed*. JOG 1 is only possible if bit 04=0 and bit 00–03=1.

##### Bit 09, Jog 2 OFF/ON

Activates the pre-programmed speed in *parameter 8-91 Bus Jog 2 Speed*. JOG 2 is only possible if bit 04=0 and bit 00–03=1.

##### Bit 10, Data invalid/valid

Tells the drive whether the control word should be used or ignored.

Bit 10=0 causes the control word to be ignored.  
 Bit 10=1 causes the control word to be used. This function is relevant because the control word is always contained in the telegram, regardless of which type of telegram is used. For example, it is possible to turn off the control word if it is not intended to be used with updating or reading parameters.

**Bit 11, No function/slow down**

Reduces the speed reference value by the amount given in *parameter 3-12 Catch up/slow Down Value* value. When bit 11=0, no modification of the reference value occurs. When bit 11=1, the reference value is reduced.

**Bit 12, No function/catch up**

Increases the speed reference value by the amount given in *parameter 3-12 Catch up/slow Down Value*. When bit 12=0, no modification of the reference value occurs. When bit 12=1, the reference value is increased. If both slowing down and accelerating are activated (bits 11 and 12=1), slowing down has priority, for example the speed reference value is reduced.

**Bits 13/14, Set-up selection**

Selects between the 4 parameter set-ups according to *Table 14.23*.

The function is only possible if [9] *Multi Set-up* has been selected in *parameter 0-10 Active Set-up*. The selection in *parameter 8-55 Set-up Select* determines how bits 13 and 14 are linked with the corresponding function of the digital inputs. Changing set-up while running is only possible if the set-ups have been linked in *parameter 0-12 This Set-up Linked to*.

Set-up	Bit 13	Bit 14
1	0	0
2	1	0
3	0	1
4	1	1

Table 14.23 Bits 13/14 set up Options

**Bit 15, No function/Reverse**

Bit 15=0 causes no reversing.  
 Bit 15=1 causes reversing.  
 Note: In the factory setting, reversing is set to [0] *Digital input* in *parameter 8-54 Reversing Select*.

**NOTICE**

Bit 15 causes reversing only when the following is selected:

- Serial communication
- Logic or
- Logic and

**14.11.5 Status Word According to PROFIdrive Profile (STW)**

The status word notifies a master about the status of a slave.

Bit	Bit=0	Bit=1
00	Control not ready	Control ready
01	Drive not ready	Drive ready
02	Coasting	Enable
03	No error	Trip
04	OFF 2	ON 2
05	OFF 3	ON 3
06	Start possible	Start not possible
07	No warning	Warning
08	Speed≠reference	Speed=reference
09	Local operation	Bus control
10	Out of frequency limit	Frequency limit ok
11	No operation	In operation
12	Drive OK	Stopped, auto start
13	Voltage OK	Voltage exceeded
14	Torque OK	Torque exceeded
15	Timer OK	Timer exceeded

Table 14.24 Bit Values for Status Word, PROFIdrive Profile

**Explanation of the status bits**

**Bit 00, Control not ready/ready**

When bit 00=0, bit 00, 01 or 02 of the control word is 0 (OFF 1, OFF 2 or OFF 3) - or the drive is switched off (trip). When bit 00=1, the drive control is ready, but there is not necessarily supply to the unit present (in the event of 24 V external supply to the control system).

**Bit 01, VLT not ready/ready**

Same significance as bit 00, however, there is a supply of the power unit. The drive is ready when it receives the necessary start signals.

**Bit 02, Coasting/enable**

When bit 02=0, bit 00, 01, or 02 of the control word is 0 (OFF 1, OFF 2 or OFF 3 or coasting) - or the drive is switched off (trip).  
 When bit 02=1, bit 00, 01, or 02 of the control word is 1; the drive has not tripped.

**Bit 03, No error/trip**

When bit 03=0, no error condition of the drive exists. When bit 03=1, the drive has tripped and requires a reset signal before it can start.

**Bit 04, ON 2/OFF 2**

When bit 01 of the control word is 0, then bit 04=0. When bit 01 of the control word is 1, then bit 04=1.

**Bit 05, ON 3/OFF 3**

When bit 02 of the control word is 0, then bit 05=0. When bit 02 of the control word is 1, then bit 05=1.

**Bit 06, Start possible/start not possible**

If [1] *PROFdrive profile* is selected in *parameter 8-10 Control Word Profile*, bit 06 is 1 after a switch-off acknowledgement, after activation of OFF2 or OFF3, and after switching on the mains voltage. Start not possible is reset with bit 00 of the control word being set to 0 and bit 01, 02, and 10 being set to 1.

**Bit 07, No warning/Warning**

Bit 07=0 means that there are no warnings.  
Bit 07=1 means that a warning has occurred.

**Bit 08, Speed  $\neq$  reference/speed=reference**

When bit 08=0, the current speed of the motor deviates from the set speed reference value. This scenario can occur, for example, when the speed is being changed during start/stop through ramp up/down.  
When bit 08=1, the current speed of the motor corresponds to the set speed reference value.

**Bit 09, Local operation/bus control**

Bit 09=0 indicates that the drive is stopped with the [Stop] key on the LCP, or that option [2] *Linked to Hand/Auto* or [0] *Local* is selected in *parameter 3-13 Reference Site*.  
When bit 09=1, the drive can be controlled through the serial interface.

**Bit 10, Out of frequency limit/frequency limit OK**

When bit 10=0, the output frequency is outside the limits set in *parameter 4-52 Warning Speed Low* and *parameter 4-53 Warning Speed High*.  
When bit 10=1, the output frequency is within the indicated limits.

**Bit 11, No operation/operation**

When bit 11=0, the motor does not turn.  
When bit 11=1, the drive has a start signal, or the output frequency is higher than 0 Hz.

**Bit 12, Drive OK/stopped, auto start**

When bit 12=0, there is no temporary overloading of the inverter.  
When bit 12=1, the inverter has stopped due to overloading. However, the drive has not switched off (trip) and will start again after the overloading has ended.

**Bit 13, Voltage OK/voltage exceeded**

When bit 13=0, the voltage limits of the drive are not exceeded.  
When bit 13=1, the direct voltage in the intermediate circuit of the drive is too low or too high.

**Bit 14, Torque OK/torque exceeded**

When bit 14=0, the motor torque is below the limit selected in *parameter 4-16 Torque Limit Motor Mode* and *parameter 4-17 Torque Limit Generator Mode*.  
When bit 14=1, the limit selected in *parameter 4-16 Torque Limit Motor Mode* or *parameter 4-17 Torque Limit Generator Mode* is exceeded.

**Bit 15, Timer OK/timer exceeded**

When bit 15=0, the timers for the motor thermal protection and thermal drive protection have not exceeded 100%.  
When bit 15=1, 1 of the timers has exceeded 100%.

**Index**

**A**

Abbreviations..... 225

AC brake..... 39

Acoustic noise..... 190

Active reference..... 200

Airflow

  Back-channel..... 65, 66

  Enclosure..... 65, 66

  External ducting..... 162

  Required..... 161

Alarm reset..... 210

Altitude..... 163

Ambient conditions

  Overview..... 159

  Specifications..... 60

Analog

  Input specifications..... 61

  Input/output descriptions and default settings..... 175

  Output specifications..... 62

  Wiring configuration for speed reference..... 208

ATEX monitoring..... 23, 160

Auto on..... 200

Automatic energy optimization (AEO)..... 21

Automatic motor adaptation (AMA)

  Overview..... 22

  Wiring configuration..... 208

Automatic switching frequency modulation..... 21

**B**

Back-channel cooling..... 161

Bandwidth management..... 38

Brake resistor

  Definition..... 225

  Design guide..... 5

  Formula for rated power..... 224

  Ordering..... 223

  Overview..... 44

  Safety..... 6, 187

  Selecting..... 186

  Terminals..... 170

  Wiring schematic..... 166

Braking

  Control with brake function..... 187

  Dynamic braking..... 39

  Limits..... 187

  Use as an alternative brake function..... 188

Branch circuit protection..... 177

Break-away torque..... 225

Building management system (BMS)..... 27

**C**

Cable clamp..... 171

Cables

  Brake..... 170

  Control..... 171

  Equalizing..... 172

  Maximum number and size per phase..... 48, 54

  Motor cables..... 183

  Opening..... 67

  Power connections..... 167

  Routing..... 172

  Shielding..... 169, 195

  Specifications..... 48, 54, 61

  Type and ratings..... 165

Calculations

  Brake resistance..... 187

  Braking torque..... 187

  Harmonic software..... 199

  Resistor duty cycle..... 186

  Scaled reference..... 201

  Short-circuit ratio..... 198

  THDi..... 197

Capacitor storage..... 158

Cascade controller

  Wiring diagram..... 213

CAV system..... 32

CE mark..... 8

Central VAV systems..... 32

Circuit breaker..... 177, 181, 189

Closed loop..... 204, 205

CO2 sensor..... 32

Coasting..... 238

Commercial environment..... 193

Common-mode filter..... 45

Compliance

  Directives..... 8

  With ADN..... 7

Condensation..... 159

Condenser pumps..... 34

Conducted emission..... 192

Constant air volume..... 32

Control

  Characteristics..... 63

  Description of operation..... 200

  Structures..... 204

  Types of..... 205, 206

Control cables..... 171, 175

Control card

  Overtemperature trip point..... 48, 54

  RS485 specifications..... 62

  Specifications..... 64

Control terminals..... 173

Conventions..... 5

Cooling		Drive	
Dust warning.....	159	Clearance requirements.....	161
Enclosure airflow rates.....	161	Configurator.....	216
Overview of back-channel cooling.....	161	Ordering.....	216
Requirements.....	161	Overview.....	13, 14
Tower fan.....	33	Power ratings.....	13, 14
Cos φ compensation.....	29	DU/dt.....	190
CSA/cUL approval.....	9	Duct cooling.....	161
Current		Duty cycle	
Distortion.....	197	Calculation.....	186
Formula for current limit.....	224	Definition.....	225
Fundamental current.....	197	<b>E</b>	
Harmonic current.....	197	E1 enclosure	
Internal current control.....	207	Exterior dimensions.....	67
Leakage current.....	188	Gland plate.....	68
Mitigating motor.....	186	Terminal dimensions.....	69
Rated output current.....	224	E2 enclosure	
Transient ground.....	189	Exterior dimensions.....	75
<b>D</b>		Gland plate.....	76
Dampers.....	32	Terminal dimensions.....	76
DC brake.....	39, 237	EAC mark.....	9
DC bus		Efficiency	
Description of operation.....	200	Calculation.....	189
Terminals.....	169	Formula for drive efficiency.....	224
Delta.....	29	Specifications.....	48, 54
Derating		Using AMA.....	22
Automatic feature.....	21	Electrical installation.....	175
External ducting.....	162	Electromagnetic interference.....	22
High Switching Frequency.....	22	Electronic thermal overload.....	23
Overview.....	162	Electronic thermal relay (ETR).....	165
Specifications.....	60, 161	EMC	
Tables.....	164	Compatibility.....	194
DeviceNet.....	42, 222	Directive.....	8
Digital		General aspects.....	191
Input specifications.....	61	Installation.....	196
Input/output descriptions and default settings.....	174	Interference.....	195
Output specifications.....	62	RS485 installation precautions.....	227
Dimensions		Test results.....	192
E1 enclosure.....	67	Emission requirements.....	193
E2 enclosure.....	75	Enclosure protection.....	10
F1 enclosure.....	83	Encoder	
F10 enclosure.....	130	Definition.....	225
F11 enclosure.....	136	Energy	
F12 enclosure.....	144	Efficiency class.....	60
F13 enclosure.....	150	Savings.....	26, 27, 28
F2 enclosure.....	90	Environment.....	60, 159
F3 enclosure.....	97	ErP directive.....	8
F4 enclosure.....	109	EtherNet/IP.....	43
F8 enclosure.....	120	Explosive atmosphere.....	159
F9 enclosure.....	124	Export control regulations.....	9
Table.....	13, 14	Extended relay card.....	44
Discharge time.....	6	Exterior dimensions (illustrations).....	67
Door clearance.....	67	External alarm reset wiring configuration.....	210

**F**

F1 enclosure  
 Exterior dimensions..... 83  
 Gland plate..... 84  
 Terminal dimensions..... 85

F10 enclosure  
 Exterior dimensions..... 130  
 Gland plate..... 131  
 Terminal dimensions..... 132

F11 enclosure  
 Exterior dimensions..... 136  
 Gland plate..... 137  
 Terminal dimensions..... 138

F12 enclosure  
 Exterior dimensions..... 144  
 Gland plate..... 145  
 Terminal dimensions..... 146

F13 enclosure  
 Exterior dimensions..... 150  
 Gland plate..... 151  
 Terminal dimensions..... 152

F2 enclosure  
 Exterior dimensions..... 90  
 Gland plate..... 91  
 Terminal dimensions..... 92

F3 enclosure  
 Exterior dimensions..... 97  
 Gland plate..... 98  
 Terminal dimensions..... 99

F4 enclosure  
 Exterior dimensions..... 109  
 Gland plate..... 110  
 Terminal dimensions..... 111

F8 enclosure  
 Exterior dimensions..... 120  
 Gland plate..... 121  
 Terminal dimensions..... 122

F9 enclosure  
 Exterior dimensions..... 124  
 Gland plate..... 125  
 Terminal dimensions..... 126

Fans  
 External supply..... 170  
 Required airflow..... 161  
 Temperature-controlled fans..... 22

FC profile..... 237

Feedback  
 Conversion..... 204  
 Handling..... 203  
 Signal..... 205

Fieldbus..... 42, 172

**Filters**

Common-mode filter..... 45  
 DU/dt filter..... 44  
 Harmonic filter..... 45  
 Ordering..... 223  
 RFI filter..... 194  
 Sine-wave filter..... 44, 169

Flying start..... 24

**Formula**

Current limit..... 224  
 Drive efficiency..... 224  
 Output current..... 224  
 Rated power of the brake resistor..... 224

Fourier series analysis..... 197

Frequency bypass..... 25

**Fuses**

Compliance..... 177  
 Control transformer..... 180  
 Fan..... 179  
 For use with power connections..... 167  
 Mains..... 180  
 Mains contactor..... 183  
 Mains disconnect..... 182  
 Manual motor controller..... 180  
 Options..... 178  
 Overcurrent protection warning..... 165  
 Pilz relay..... 180  
 Power/semiconductor..... 177  
 Specifications for 380–480 V..... 48  
 Specifications for 525–690 V..... 54  
 Supplementary..... 179

**G**

Galvanic isolation..... 22, 62, 194

Gases..... 159

General purpose I/O module..... 43

Gland plate..... 67

Grounding..... 22, 171, 188

**H**

Hand on..... 200

Harmonics  
 Definition of power factor..... 225  
 EN standards..... 198  
 Filter..... 45  
 IEC standards..... 198  
 Mitigation..... 199  
 Overview..... 197

Heat sink  
 Cleaning..... 159  
 Overtemperature trip point..... 48, 54  
 Required airflow..... 161

Heater  
 Usage..... 159  
 Wiring schematic..... 166

High voltage warning..... 6



High-altitude installation.....	195
Humidity.....	159
<b>I</b>	
IGVs.....	32
Immunity requirements.....	193
Input specifications.....	61
Installation	
Electrical.....	165
Qualified personnel.....	6
Requirements.....	160
Insulation.....	186
Inverter.....	200
IP rating.....	10
IT grid.....	189
<b>K</b>	
Kinetic back-up.....	24
Kits	
Descriptions.....	222
Enclosure availability.....	19
Ordering numbers.....	222
<b>L</b>	
Language packages.....	216
Laws of proportionality.....	27
Leakage current.....	6, 188
Lifting.....	158
Load share	
Overview.....	40
Short-circuit protection.....	20
Terminals.....	40, 169
Warning.....	6
Wiring schematic.....	166
Local speed determination.....	36
Low voltage	
Directive.....	8
Low-speed operation.....	163
<b>M</b>	
Machinery directive.....	8
Mains	
Contactor.....	183
Disconnect.....	182
Drop-out.....	24
Fluctuations.....	22
Shield.....	6
Specifications.....	60
Maintenance.....	159
Marine certification.....	9

Modbus	
Message structure.....	233
Option.....	43
RTU message function codes.....	236
RTU overview.....	232
Modulation.....	21, 224
Motor	
Break-away torque.....	225
Cables.....	169, 183, 188
Class protection.....	159
Ex-d.....	44
Ex-e.....	23
Full torque.....	24
Insulation.....	186
Leakage current.....	188
Missing phase detection.....	20
Mitigating bearing currents.....	186
Nameplate.....	24
Output specifications.....	60
Parallel connection.....	184
Rotation.....	184
Thermal protection.....	23, 184
Thermistor wiring configuration.....	212
Wiring schematic.....	166
Mounting configurations.....	160
<b>N</b>	
NEMA protection rating.....	10
Network connection.....	226
<b>O</b>	
Open loop.....	204
Operating guide.....	5
Options	
Enclosure availability.....	13, 14
Fieldbus.....	42
Functional extensions.....	43
Fuses.....	178
Motion control.....	44
Ordering.....	45, 220, 222, 223
Relay cards.....	44
Ordering form type code.....	216
Output	
Contactor.....	189, 196
Specifications.....	62
Switch.....	21
Overcurrent protection.....	165
Overload	
Electronic thermal overload.....	23
Issue with harmonics.....	197
Limits.....	21
Overtemperature.....	225
Overvoltage	
Alternative brake function.....	188
Braking.....	44
Protection.....	20

**P**

PC connection..... 171

PELV..... 22, 62, 194

Periodic forming..... 158

Personal computer..... 171

PID  
 Control..... 29  
 Controller..... 22, 203, 206

Pigtails..... 195

PLC..... 172

Point of common coupling..... 197

Potentiometer..... 174, 210

Power  
 Connections..... 167  
 Factor..... 225  
 Losses..... 48, 54  
 Ratings..... 12, 48, 54

Preheat..... 25

Primary pumps..... 35

Process control..... 206

PROFIBUS..... 42, 222

PROFINET..... 42

Programming guide..... 5

Protection  
 Brake function..... 20  
 Enclosure rating..... 13, 14  
 Motor thermal..... 23  
 Overcurrent..... 165  
 Overload..... 21  
 Overvoltage..... 20  
 Rating..... 10  
 Short circuit..... 20  
 Supply voltage imbalance..... 21

Protocol overview..... 227

PTC thermistor card..... 44

Pulse  
 Input specifications..... 62  
 Wiring configuration for start/stop..... 209

Pump  
 Condenser..... 34  
 Efficiency..... 38  
 Primary..... 35  
 Secondary..... 37  
 Staging..... 38

**Q**

Qualified personnel..... 6

**R**

Radiated emission..... 192

Radio frequency interference..... 22

RCM mark..... 9

Rectifier..... 200

Reference  
 Active reference..... 200  
 Remote handling of..... 201  
 Remote reference..... 201  
 Speed input..... 208, 209

Regen  
 Availability..... 13, 14  
 Overview..... 41  
 Terminals..... 89, 96, 108, 119, 217

Relay  
 ADN-compliant installation..... 7  
 Card..... 44  
 Extended relay card option..... 44  
 Option..... 43  
 Specifications..... 63  
 Terminals..... 175

Remote reference..... 201

Residential environment..... 193

Residual current device..... 188, 189

Resistor brake..... 39

Resonance damping..... 22

Restart..... 24

RFI  
 Filter..... 194  
 Using switch with IT grid..... 189

Rise time..... 190

Rotor..... 21

RPM..... 27

RS485  
 Installation..... 226  
 Overview..... 226  
 Parameter values..... 237  
 Terminals..... 174  
 Wiring configuration..... 211  
 Wiring schematic..... 166

**S**

Safe Torque Off  
 Machinery directive compliance..... 8  
 Operating guide..... 5  
 Overview..... 26  
 Terminal location..... 174  
 Wiring configuration..... 209  
 Wiring schematic..... 166

Safety  
 Instructions..... 6, 165

Scaled reference..... 201

Secondary pumps..... 37

Sensor input option..... 44

Serial communication..... 174

Shielded..... 175

Shielding		Terminals	
Cables.....	169, 171	Analog input/output.....	175
Mains.....	6	Brake resistor.....	170
Twisted ends.....	195	Control descriptions and default settings.....	173
Short circuit		Digital input/output.....	174
Braking.....	39, 187	Dimensions for E1 enclosure.....	69
Definition.....	225	Dimensions for E2 enclosure.....	76
Protection.....	20, 177	Dimensions for F1 enclosure.....	85
Ratio calculation.....	198	Dimensions for F10 enclosure.....	132
SCCR rating.....	178	Dimensions for F11 enclosure.....	138
Sine-wave filter.....	44, 169	Dimensions for F12 enclosure.....	146
Slip compensation.....	225	Dimensions for F13 enclosure.....	152
Smart logic control		Dimensions for F2 enclosure.....	92
Overview.....	25	Dimensions for F3 enclosure.....	99
Wiring configuration.....	214	Dimensions for F4 enclosure.....	111
Soft starter.....	29	Dimensions for F8 enclosure.....	122
Software versions.....	222	Dimensions for F9 enclosure.....	126
Spare parts.....	223	Load share.....	169
Speed		Relay terminals.....	175
Control.....	205	RS485.....	174
PID feedback.....	205	Serial communication.....	174
Wiring configuration for speed reference.....	210	Terminal 37.....	174
Wiring configuration for speed up/down.....	211	Thermistor	
Start/stop wiring configuration.....	209, 210	Cable routing.....	172
STO.....	5	Definition.....	225
see also <i>Safe Torque Off</i>		Terminal location.....	174
Storage.....	158	Wiring configuration.....	212
Switch		Torque	
A53 and A54.....	61, 175	Characteristic.....	60
Disconnect.....	46	Control.....	206
Switching frequency		Transducer.....	174
Derating.....	21	Transformer	
Power connections.....	169	Connection.....	170
Sine-wave filter.....	44, 169	Effects of harmonics.....	197
Use with RCDs.....	189	Trip	
T		Definition.....	225
Telegram length (LGE).....	228	Points for 380–480 V drives.....	48
Temperature.....	159	Points for 525–690 V drives.....	54
		TÜV certificate.....	9
		Type code.....	216
		U	
		UKrSEPRO certificate.....	9
		UL	
		Enclosure protection rating.....	10
		Listing mark.....	8
		USB specifications.....	64
		User input.....	200
		V	
		Variable air volume.....	32
		VAV.....	32
		Voltage imbalance.....	21
		VVC+.....	207

## W

Warnings.....	6, 165
Wires.....	165
see also <i>Cables</i>	
Wiring diagram	
Cascade controller.....	213
Fixed variable speed pump.....	214
Lead pump alternation.....	214
Wiring schematic	
Drive.....	166
Power connections.....	167
Typical application examples.....	208





.....  
Danfoss can accept no responsibility for possible errors in catalogues, brochures and other printed material. Danfoss reserves the right to alter its products without notice. This also applies to products already on order provided that such alterations can be made without subsequential changes being necessary in specifications already agreed. All trademarks in this material are property of the respective companies. Danfoss and the Danfoss logotype are trademarks of Danfoss A/S. All rights reserved.  
.....

Danfoss A/S  
Ulsnaes 1  
DK-6300 Graasten  
vlt-drives.danfoss.com

