



Design Guide

VLT[®] Refrigeration Drive FC 103

1.1–90 kW



Contents

1 Introduction	7
1.1 Purpose of the Design Guide	7
1.2 Organisation	7
1.3 Additional Resources	7
1.4 Abbreviations, Symbols and Conventions	8
1.5 Safety Symbols	9
1.6 Definitions	9
1.7 Document and Software Version	10
1.8 Approvals and Certifications	10
1.8.1 CE Mark	10
1.8.1.1 Low Voltage Directive	10
1.8.1.2 EMC Directive	10
1.8.1.3 Machinery Directive	11
1.8.1.4 ErP Directive	11
1.8.2 C-tick Compliance	11
1.8.3 UL Compliance	11
1.8.4 Marine Compliance (ADN)	11
1.8.5 Export Control Regulations	12
1.9 Safety	12
1.9.1 General Safety Principles	12
2 Product Overview	14
2.1 Introduction	14
2.2 Description of Operation	17
2.3 Sequence of Operation	18
2.3.1 Rectifier Section	18
2.3.2 Intermediate Section	18
2.3.3 Inverter Section	18
2.4 Control Structures	19
2.4.1 Control Structure Open Loop	19
2.4.2 Control Structure Closed Loop	19
2.4.3 Local (Hand On) and Remote (Auto On) Control	20
2.4.4 Reference Handling	21
2.4.5 Feedback Handling	23
2.5 Automated Operational Functions	24
2.5.1 Short-circuit Protection	24
2.5.2 Overvoltage Protection	24
2.5.3 Missing Motor Phase Detection	24
2.5.4 Mains Phase Imbalance Detection	25

2.5.5 Switching on the Output	25
2.5.6 Overload Protection	25
2.5.7 Automatic Derating	25
2.5.8 Automatic Energy Optimisation	25
2.5.9 Automatic Switching Frequency Modulation	25
2.5.10 Automatic Derating for High Switching Frequency	26
2.5.11 Automatic Derating for Overtemperature	26
2.5.12 Auto Ramping	26
2.5.13 Current Limit Circuit	26
2.5.14 Power Fluctuation Performance	26
2.5.15 Motor Soft Start	26
2.5.16 Resonance Damping	26
2.5.17 Temperature-controlled Fans	26
2.5.18 EMC Compliance	26
2.5.19 Current Measurement on All Three Motor Phases	27
2.5.20 Galvanic Isolation of Control Terminals	27
2.6 Custom Application Functions	27
2.6.1 Automatic Motor Adaptation	27
2.6.2 Motor Thermal Protection	27
2.6.3 Mains Drop-out	27
2.6.4 Built-in PID Controllers	28
2.6.5 Automatic Restart	28
2.6.6 Flying Start	28
2.6.7 Full Torque at Reduced Speed	28
2.6.8 Frequency Bypass	28
2.6.9 Motor Preheat	28
2.6.10 Four Programmable Set-ups	29
2.6.11 DC Braking	29
2.6.12 Sleep Mode	29
2.6.13 Run Permissive	29
2.6.14 Smart Logic Control (SLC)	29
2.6.15 Safe Torque Off Function	30
2.7 Fault, Warning and Alarm Functions	31
2.7.1 Operation at Overtemperature	31
2.7.2 High and Low Reference Warning	31
2.7.3 High and Low Feedback Warning	31
2.7.4 Phase Imbalance or Phase Loss	31
2.7.5 High Frequency Warning	31
2.7.6 Low Frequency Warning	31
2.7.7 High Current Warning	31

2.7.8 Low Current Warning	31
2.7.9 No Load/Broken Belt Warning	31
2.7.10 Lost Serial Interface	32
2.8 User Interfaces and Programming	32
2.8.1 Local Control Panel	32
2.8.2 PC Software	33
2.8.2.1 MCT 10 Set-up Software	33
2.8.2.2 VLT® Harmonics Calculation Software MCT 31	33
2.8.2.3 Harmonic Calculation Software (HCS)	33
2.9 Maintenance	34
2.9.1 Storage	34
3 System Integration	35
3.1 Ambient Operating Conditions	35
3.1.1 Humidity	35
3.1.2 Temperature	36
3.1.3 Cooling	36
3.1.4 Motor-generated Overvoltage	37
3.1.5 Acoustic Noise	37
3.1.6 Vibration and Shock	37
3.1.7 Aggressive Atmospheres	37
3.1.8 IP Rating Definitions	38
3.1.9 Radio Frequency Interference	39
3.1.10 PELV and Galvanic Isolation Compliance	39
3.2 EMC, Harmonics, and Ground Leakage Protection	40
3.2.1 General Aspects of EMC Emissions	40
3.2.2 EMC Test Results (Emission)	42
3.2.3 Emission Requirements	43
3.2.4 Immunity Requirements	43
3.2.5 Motor Insulation	44
3.2.6 Motor Bearing Currents	44
3.2.7 Harmonics	45
3.2.8 Ground Leakage Current	47
3.3 Energy Efficiency	49
3.3.1 IE and IES Classes	50
3.3.2 Power Loss Data and Efficiency Data	50
3.3.3 Losses and Efficiency of a Motor	51
3.3.4 Losses and Efficiency of a Power Drive System	51
3.4 Mains Integration	51
3.4.1 Mains Configurations and EMC Effects	51

3.4.2 Low-frequency Mains Interference	52
3.4.3 Analysing Mains Interference	53
3.4.4 Options for Reducing Mains Interference	53
3.4.5 Radio Frequency Interference	53
3.4.6 Classification of the Operating Site	53
3.4.7 Use with Isolated Input Source	54
3.4.8 Power Factor Correction	54
3.4.9 Input Power Delay	54
3.4.10 Mains Transients	54
3.4.11 Operation with a Standby Generator	54
3.5 Motor Integration	55
3.5.1 Motor Selection Considerations	55
3.5.2 Sine-wave and dU/dt Filters	55
3.5.3 Proper Motor Grounding	55
3.5.4 Motor Cables	55
3.5.5 Motor Cable Shielding	56
3.5.6 Connection of Multiple Motors	56
3.5.7 Motor Thermal Protection	57
3.5.8 Output Contactor	58
3.5.9 Energy Efficiency	58
3.6 Additional Inputs and Outputs	59
3.6.1 Wiring Schematic	59
3.6.2 Relay Connections	60
3.6.3 EMC-compliant Electrical Connection	61
3.7 Mechanical Planning	62
3.7.1 Clearance	62
3.7.2 Wall Mounting	63
3.7.3 Access	63
3.8 Options and Accessories	63
3.8.1 Communication Options	66
3.8.2 Input/Output, Feedback, and Safety Options	66
3.8.3 Sine-wave Filters	66
3.8.4 dU/dt Filters	66
3.8.5 Harmonic Filters	66
3.8.6 IP21/NEMA Type 1 Enclosure Kit	67
3.8.7 Common-mode Filters	69
3.8.8 Remote Mounting Kit for LCP	69
3.8.9 Mounting Bracket for Enclosure Sizes A5, B1, B2, C1, and C2	70
3.9 Serial Interface RS485	71
3.9.1 Overview	71

3.9.2 Network Connection	72
3.9.3 RS485 Bus Termination	72
3.9.4 EMC Precautions	73
3.9.5 FC Protocol Overview	73
3.9.6 Network Configuration	73
3.9.7 FC Protocol Message Framing Structure	73
3.9.8 FC Protocol Examples	77
3.9.9 Modbus RTU Protocol	78
3.9.10 Modbus RTU Message Framing Structure	79
3.9.11 Access to Parameters	82
3.9.12 FC Drive Control Profile	83
3.10 System Design Checklist	89
4 Application Examples	91
4.1 Application Examples	91
4.2 Selected Application Features	91
4.2.1 SmartStart	91
4.2.2 Start/Stop	92
4.2.3 Pulse Start/Stop	92
4.2.4 Potentiometer Reference	93
4.3 Application Set-up Examples	93
5 Special Conditions	99
5.1 Derating	99
5.2 Manual Derating	99
5.3 Derating for Long Motor Cables or Cables with Larger Cross-section	99
5.4 Derating for Ambient Temperature	100
6 Type Code and Selection	104
6.1 Ordering	104
6.1.1 Introduction	104
6.1.2 Type Code	104
6.2 Options, Accessories, and Spare Parts	105
6.2.1 Ordering Numbers: Options and Accessories	105
6.2.2 Ordering Numbers: Harmonic Filters	107
6.2.3 Ordering Numbers: Sine-wave Filter Modules, 200–480 V AC	107
6.2.4 Ordering Numbers: Sine-wave Filter Modules, 525–600/690 V AC	108
6.2.5 Harmonic Filters	109
6.2.6 Sine-wave Filters	111
6.2.7 dU/dt Filters	113
6.2.8 Common Mode Filters	114

7 Specifications	115
7.1 Electrical Data	115
7.1.1 Mains Supply 3x200–240 V AC	115
7.1.2 Mains Supply 3x380–480 V AC	117
7.1.3 Mains Supply 3x525–600 V AC	119
7.2 Mains Supply	121
7.3 Motor Output and Motor Data	121
7.4 Ambient Conditions	122
7.5 Cable Specifications	122
7.6 Control Input/Output and Control Data	123
7.7 Connection Tightening Torque	126
7.8 Fuses and Circuit Breakers	127
7.9 Power Ratings, Weight, and Dimensions	132
7.10 dU/dt Testing	133
7.11 Acoustic Noise Ratings	135
7.12 Selected Options	135
7.12.1 VLT® General Purpose I/O Module MCB 101	135
7.12.2 VLT® Relay Card MCB 105	136
7.12.3 VLT® Extended Relay Card MCB 113	138
8 Appendix - Selected Drawings	140
8.1 Mains Connection Drawings	140
8.2 Motor Connection Drawings	143
8.3 Relay Terminal Drawings	145
8.4 Cable Entry Holes	146
Index	151

1 Introduction

1.1 Purpose of the Design Guide

This design guide for VLT® Refrigeration Drive FC 103 frequency converters is intended for:

- Project and systems engineers.
- Design consultants.
- Application and product specialists.

The design guide provides technical information to understand the capabilities of the frequency converter for integration into motor control and monitoring systems.

The purpose of the design guide is to provide design considerations and planning data for integration of the frequency converter into a system. The design guide caters for selection of frequency converters and options for a diversity of applications and installations.

Reviewing the detailed product information in the design stage enables developing a well-conceived system with optimal functionality and efficiency.

VLT® is a registered trademark.

1.2 Organisation

Chapter 1 Introduction: The general purpose of the design guide and compliance with international directives.

Chapter 2 Product Overview: The internal structure and functionality of the frequency converter and operational features.

Chapter 3 System Integration: Environmental conditions; EMC, harmonics, and ground leakage; mains input; motors and motor connections; other connections; mechanical planning; and descriptions of options and accessories available.

Chapter 4 Application Examples: Samples of product applications and guidelines for use.

Chapter 5 Special Conditions: Details on unusual operational environments.

Chapter 6 Type Code and Selection: Procedures for ordering equipment and options to meet the intended use of the system.

Chapter 7 Specifications: A compilation of technical data in table and graphics format.

Chapter 8 Appendix - Selected Drawings: A compilation of graphics illustrating:

- Mains and motor connections
- Relay terminals
- Cable entries

1.3 Additional Resources

Resources available to understand advanced operation of the frequency converter, programming, and directives compliance:

- The *VLT® Refrigeration Drive FC 103 Operating Instructions* (referenced as *operating instructions* in this manual) provide detailed information for the installation and start-up of the frequency converter.
- The *VLT® Refrigeration Drive FC 103 Design Guide* provides information required for design and planning for integration of the frequency converter into a system.
- The *VLT® Refrigeration Drive FC 103 Programming Guide* (referenced as *programming guide* in this manual) provides greater detail about how to work with parameters and many application examples.
- The *VLT® Safe Torque Off Operating Instructions* describe how to use Danfoss frequency converters in functional safety applications. This manual is supplied with the frequency converter when the STO option is present.

Supplemental publications and manuals are available for download from vlt-drives.danfoss.com/Products/Detail/Technical-Documents.

NOTICE

Optional equipment is available that may change some of the information described in these publications. Be sure to see the instructions supplied with the options for specific requirements.

Contact a Danfoss supplier or visit www.danfoss.com for more information.

1.4 Abbreviations, Symbols and Conventions

60° AVM	60° asynchronous vector modulation
A	Ampere/AMP
AC	Alternating current
AD	Air discharge
AEO	Automatic energy optimisation
AI	Analog input
AMA	Automatic motor adaptation
AWG	American wire gauge
°C	Degrees celsius
CD	Constant discharge
CDM	Complete drive module: the frequency converter, feeding section and auxiliaries
CM	Common mode
CT	Constant torque
DC	Direct current
DI	Digital input
DM	Differential mode
D-TYPE	Drive dependent
EMC	Electromagnetic compatibility
EMF	Electromotive force
ETR	Electronic thermal relay
f _{JOG}	Motor frequency when jog function is activated.
f _M	Motor frequency
f _{MAX}	Maximum output frequency, the frequency converter applies on its output.
f _{MIN}	Minimum motor frequency from the frequency converter
f _{M,N}	Nominal motor frequency
FC	Frequency converter
g	Gramme
Hiperface®	Hiperface® is a registered trademark by Stegmann
HO	High overload
hp	Horse power
HTL	HTL encoder (10–30 V) pulses - High-voltage transistor logic
Hz	Hertz
I _{INV}	Rated inverter output current
I _{LIM}	Current limit
I _{M,N}	Nominal motor current
I _{VLT,MAX}	Maximum output current
I _{VLT,N}	Rated output current supplied by the frequency converter
kHz	Kilohertz
LCP	Local control panel
lsb	Least significant bit
m	Meter
mA	Milliampere
MCM	Mille circular mil
MCT	Motion control tool
mH	Inductance in milli Henry
mm	Millimeter

ms	Millisecond
msb	Most significant bit
η _{VLT}	Efficiency of the frequency converter defined as ratio between power output and power input.
nF	Capacitance in nano Farad
NLCP	Numerical local control panel
Nm	Newton meter
NO	Normal overload
n _s	Synchronous motor speed
Online/Offline Parameters	Changes to online parameters are activated immediately after the data value is changed.
P _{br,cont.}	Rated power of the brake resistor (average power during continuous braking).
PCB	Printed circuit board
PCD	Process data
PDS	Power drive system: a CDM and a motor
PELV	Protective extra low voltage
P _m	Frequency converter nominal output power as high overload (HO).
P _{M,N}	Nominal motor power
PM motor	Permanent magnet motor
Process PID	PID (Proportional Integrated Differential) regulator that maintains the speed, pressure, temperature, and so on.
R _{br,nom}	Nominal resistor value that ensures a brake power on the motor shaft of 150/160% for 1 minute
RCD	Residual current device
Regen	Regenerative terminals
R _{min}	Minimum permissible brake resistor value by frequency converter
RMS	Root mean square
RPM	Revolutions per minute
R _{rec}	Recommended brake resistor resistance of Danfoss brake resistors
s	Second
SFAVM	Stator flux-oriented asynchronous vector modulation
STW	Status word
SMPS	Switch mode power supply
THD	Total harmonic distortion
T _{LIM}	Torque limit
TTL	TTL encoder (5 V) pulses - transistor transistor logic
U _{M,N}	Nominal motor voltage
V	Volts
VT	Variable torque
VVC+	Voltage vector control plus

Table 1.1 Abbreviations

Conventions

Numbered lists indicate procedures.

Bullet lists indicate other information and description of illustrations.

Italicised text indicates:

- Cross reference.
- Link.
- Footnote.
- Parameter name, parameter group name, parameter option.

All dimensions are in mm (inch).

* indicates a default setting of a parameter.

1.5 Safety Symbols

The following symbols are used in this manual:



Indicates a potentially hazardous situation that could result in death or serious injury.



Indicates a potentially hazardous situation that could result in minor or moderate injury. It can also be used to alert against unsafe practices.



Indicates important information, including situations that can result in damage to equipment or property.

1.6 Definitions**Coast**

The motor shaft is in free mode. No torque on the motor.

CT characteristics

Constant torque characteristics used for all applications such as:

- Conveyor belts.
- Displacement pumps.
- Cranes.

Initialising

If initialising is carried out (*parameter 14-22 Operation Mode*), the frequency converter returns to the default setting.

Intermittent duty cycle

An intermittent duty rating refers to a sequence of duty cycles. Each cycle consists of an on-load and an off-load period. The operation can be either periodic duty or non-periodic duty.

Power factor

The true power factor (lambda) considers all the harmonics. The true power factor is always smaller than the power factor (cosphi) that only considers the 1st harmonics of current and voltage.

$$\cos\phi = \frac{P \text{ (kW)}}{P \text{ (kVA)}} = \frac{U\lambda \times I\lambda \times \cos\phi}{U\lambda \times I\lambda}$$

Cosphi is also known as displacement power factor.

Both lambda and cosphi are stated for Danfoss VLT® frequency converters in *chapter 7.2 Mains Supply*.

The power factor indicates to which extent the frequency converter imposes a load on the mains supply.

The lower the power factor, the higher the I_{RMS} for the same kW performance.

In addition, a high power factor indicates that the harmonic currents are low.

All Danfoss frequency converters have built-in DC coils in the DC link. The coils ensure a high power factor and reduce the THDi on the main supply.

Set-up

Save parameter settings in 4 set-ups. Change between the 4 parameter set-ups and edit 1 set-up while another set-up is active.

Slip compensation

The frequency converter compensates for the motor slip by giving the frequency a supplement that follows the measured motor load, keeping the motor speed almost constant.

Smart logic control (SLC)

The SLC is a sequence of user-defined actions executed when the associated user-defined events are evaluated as true by the SLC. (Parameter group 13-** *Smart Logic*).

FC standard bus

Includes RS485 bus with FC protocol or MC protocol. See *parameter 8-30 Protocol*.

Thermistor

A temperature-dependent resistor placed where the temperature is to be monitored (frequency converter or motor).

Trip

A state entered in fault situations, such as when the frequency converter is subject to an overtemperature or when it protects the motor, process, or mechanism. Restart is prevented until the cause of the fault has disappeared and the trip state is cancelled. Cancel the trip state by:

- Activating reset, or
- Programming the frequency converter to reset automatically

Do not use trip for personal safety.

Trip lock

A state entered in fault situations when the frequency converter is protecting itself and requires physical intervention, for example if the frequency converter is subject to a short circuit on the output. A locked trip can only be cancelled by cutting off mains, removing the cause of the fault, and reconnecting the frequency converter. Restart is prevented until the trip state is cancelled by activating reset or, in some cases, by being programmed to reset automatically. Do not use trip for personal safety.

VT characteristics

Variable torque characteristics for pumps and fans.

1.7 Document and Software Version

This manual is regularly reviewed and updated. All suggestions for improvement are welcome.

Table 1.2 shows the document version and the corresponding software version.

Edition	Remarks	Software version
MG16G2xx	Replaces MG16G1xx	1.4x

Table 1.2 Document and Software Version

1.8 Approvals and Certifications

Frequency converters are designed in compliance with the directives described in this section.

For more information on approvals and certificates, go to the download area at vlt-marine.danfoss.com/support/type-approval-certificates/.

1.8.1 CE Mark



Illustration 1.1 CE

The CE mark (Communauté Européenne) indicates that the product manufacturer conforms to all applicable EU directives. The EU directives applicable to the design and manufacture of frequency converters are listed in Table 1.3.

NOTICE

The CE mark does not regulate the quality of the product. Technical specifications cannot be deduced from the CE mark.

NOTICE

Frequency converters with an integrated safety function must comply with the machinery directive.

EU Directive	Version
Low Voltage Directive	2014/35/EU
EMC Directive	2014/30/EU
Machinery Directive ¹⁾	2014/32/EU
ErP Directive	2009/125/EC
ATEX Directive	2014/34/EU
RoHS Directive	2002/95/EC

Table 1.3 EU Directives Applicable to Frequency Converters

¹⁾ Machinery Directive conformance is only required for frequency converters with an integrated safety function.

Declarations of conformity are available on request.

1.8.1.1 Low Voltage Directive

The Low Voltage Directive applies to all electrical equipment in the 50–1000 V AC and the 75–1600 V DC voltage ranges.

The aim of the directive is to ensure personal safety and avoid property damage, when operating electrical equipment that is installed, maintained, and used as intended.

1.8.1.2 EMC Directive

The purpose of the EMC (electromagnetic compatibility) Directive is to reduce electromagnetic interference and enhance immunity of electrical equipment and installations. The basic protection requirement of the EMC Directive is that devices that generate electromagnetic interference (EMI), or whose operation could be affected by EMI, must be designed to limit the generation of electromagnetic interference. The devices must have a suitable degree of immunity to EMI when properly installed, maintained, and used as intended.

Electrical equipment devices used alone or as part of a system must bear the CE mark. Systems do not require the CE mark, but must comply with the basic protection requirements of the EMC Directive.

1.8.1.3 Machinery Directive

The aim of the Machinery Directive is to ensure personal safety and avoid property damage for mechanical equipment used in its intended application. The Machinery Directive applies to a machine consisting of an aggregate of interconnected components or devices of which at least 1 is capable of mechanical movement.

Frequency converters with an integrated safety function must comply with the Machinery Directive. Frequency converters without a safety function do not fall under the Machinery Directive. If a frequency converter is integrated into a machinery system, Danfoss can provide information on safety aspects relating to the frequency converter.

When frequency converters are used in machines with at least 1 moving part, the machine manufacturer must provide a declaration stating compliance with all relevant statutes and safety measures.

1.8.1.4 ErP Directive

The ErP Directive is the European Ecodesign Directive for energy-related products. The directive sets ecodesign requirements for energy-related products, including frequency converters. The aim of the directive is to increase energy efficiency and the level of protection of the environment, while increasing the security of the energy supply. Environmental impact of energy-related products includes energy consumption throughout the entire product life cycle.

1.8.2 C-tick Compliance



Illustration 1.2 C-tick

The C-tick label indicates compliance with the applicable technical standards for Electromagnetic Compatibility (EMC). C-tick compliance is required for placing electrical and electronic devices on the market in Australia and New Zealand.

The C-tick regulatory is about conducted and radiated emission. For frequency converters, apply the emission limits specified in EN/IEC 61800-3.

A declaration of conformity can be provided on request.

1.8.3 UL Compliance

UL Listed



Illustration 1.3 UL

NOTICE

525–690 V frequency converters are not certified for UL.

The frequency converter complies with UL 508C thermal memory retention requirements. For more information, refer to *chapter 2.6.2 Motor Thermal Protection*.

1.8.4 Marine Compliance (ADN)

Units with ingress protection rating IP55 (NEMA 12) or higher prevent spark formation, and are classified as limited explosion risk electrical apparatus in accordance with the European Agreement concerning International Carriage of Dangerous Goods by Inland Waterways (ADN).

For units with ingress protection rating IP20/Chassis, IP21/NEMA 1, or IP54, prevent risk of spark formation as follows:

- Do not install a mains switch.
- Ensure that *parameter 14-50 RFI Filter* is set to [1] *On*.
- Remove all relay plugs marked *RELAY*. See *Illustration 1.4*.
- Check which relay options are installed, if any. The only permitted relay option is VLT[®] Extended Relay Card MCB 113.

Go to vlt-marine.danfoss.com/support/type-approval-certificates/ for additional marine approvals information.

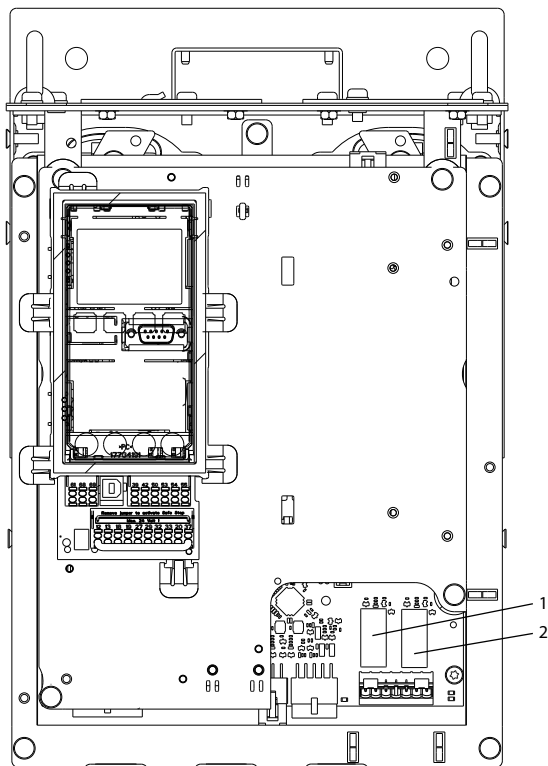

1308D832.10

1, 2	Relay plugs
------	-------------

Illustration 1.4 Location of Relay Plugs

Manufacturer declaration is available on request.

1.8.5 Export Control Regulations

Frequency converters can be subject to regional and/or national export control regulations.

The frequency converters that are subject to export control regulations are classified by an ECCN number.

The ECCN number is provided in the documents accompanying the frequency converter.

In case of re-export, it is the responsibility of the exporter to ensure compliance with the relevant export control regulations.

1.9 Safety

1.9.1 General Safety Principles

If handled improperly, frequency converters have the potential for fatal injury as they contain high-voltage components. Only qualified personnel should install and operate the equipment. Do not attempt repair work without first removing power from the frequency converter and waiting the designated amount of time for stored electrical energy to dissipate.

Strict adherence to safety precautions and notices is mandatory for safe operation of the frequency converter.

Correct and reliable transport, storage, installation, operation, and maintenance are required for the trouble-free and safe operation of the frequency converter. Only qualified personnel are allowed to install and operate this equipment.

Qualified personnel are defined as trained staff, who are authorised to install, commission, and maintain equipment, systems, and circuits in accordance with pertinent laws and regulations. Additionally, the qualified personnel must be familiar with the instructions and safety measures described in these operating instructions.

▲WARNING

HIGH VOLTAGE

Frequency converters contain high voltage when connected to AC mains input, DC supply, or load sharing. Failure to perform installation, start-up, and maintenance by qualified personnel can result in death or serious injury.

- Only qualified personnel must perform installation, start-up, and maintenance.

⚠ WARNING

UNINTENDED START

When the frequency converter is connected to AC mains, DC supply, or load sharing, the motor may start at any time. Unintended start during programming, service, or repair work can result in death, serious injury, or property damage. The motor can start via an external switch, a fieldbus command, an input reference signal from the LCP, or after a cleared fault condition.

To prevent unintended motor start:

- Disconnect the frequency converter from the mains.
- Press [Off/Reset] on the LCP before programming parameters.
- Completely wire and assemble the frequency converter, motor, and any driven equipment before connecting the frequency converter to AC mains, DC supply, or load sharing.

⚠ WARNING

DISCHARGE TIME

The frequency converter contains DC-link capacitors, which can remain charged even when the frequency converter is not powered. High voltage may be present even when the warning LED indicator lights are off. Failure to wait the specified time after power has been removed before performing service or repair work, could result in death or serious injury.

1. Stop the motor.
2. Disconnect AC mains, permanent magnet type motors, and remote DC-link supplies, including battery back-ups, UPS, and DC-link connections to other frequency converters.
3. Wait for the capacitors to discharge fully, before performing any service or repair work. The duration of waiting time is specified in *Table 1.4*.

Voltage [V]	Minimum waiting time (minutes)	
	4	15
200–240	1.1–3.7 kW	5.5–45 kW
380–480	1.1–7.5 kW	11–90 kW
525–600	1.1–7.5 kW	11–90 kW

Table 1.4 Discharge Time

⚠ WARNING

LEAKAGE CURRENT HAZARD

Leakage currents exceed 3.5 mA. Failure to ground frequency converter properly can result in death or serious injury.

- Ensure the correct grounding of the equipment by a certified electrical installer.

⚠ WARNING

EQUIPMENT HAZARD

Contact with rotating shafts and electrical equipment can result in death or serious injury.

- Ensure that only trained and qualified personnel perform installation, start-up, and maintenance.
- Ensure that electrical work conforms to national and local electrical codes.
- Follow the procedures in this manual.

⚠ WARNING

UNINTENDED MOTOR ROTATION WINDMILLING

Unintended rotation of permanent magnet motors creates voltage and can charge the unit, resulting in death, serious injury, or equipment damage.

- Ensure that permanent magnet motors are blocked to prevent unintended rotation.

⚠ CAUTION

INTERNAL FAILURE HAZARD

An internal failure in the frequency converter can result in serious injury, when the frequency converter is not properly closed.

- Ensure that all safety covers are in place and securely fastened before applying power.

2 Product Overview

2

2.1 Introduction

This chapter provides an overview of the frequency converter's primary assemblies and circuitry. It describes the internal electrical and signal processing functions. A description of the internal control structure is also included.

Also described are automated and optional frequency converter functions available for designing robust operating systems with sophisticated control and status reporting performance.

2.1.1 Product Dedication to Refrigeration Applications

The VLT® Refrigeration Drive FC 103 is designed for refrigeration applications. The integrated application wizard guides the user through the commissioning process. The range of standard and optional features includes:

- Multi-zone cascade control
- Neutral zone control.
- Floating condensing temperature control.
- Oil return management.
- Multi-feedback evaporator control.
- Cascade control.
- Dry-run detection.
- End of curve detection.
- Motor alternation.
- STO.
- Sleep mode.
- Password protection.
- Overload protection.
- Smart logic control.
- Minimum speed monitor.
- Free programmable texts for information, warnings, and alerts.

2.1.2 Energy Savings

When comparing with alternative control systems and technologies, a frequency converter is the optimum energy control system for controlling fan and pump systems.

By using a frequency converter to control the flow, a pump speed reduction of 20% leads to energy savings of about 50% in typical applications.

Illustration 2.1 shows an example of the achievable energy reduction.

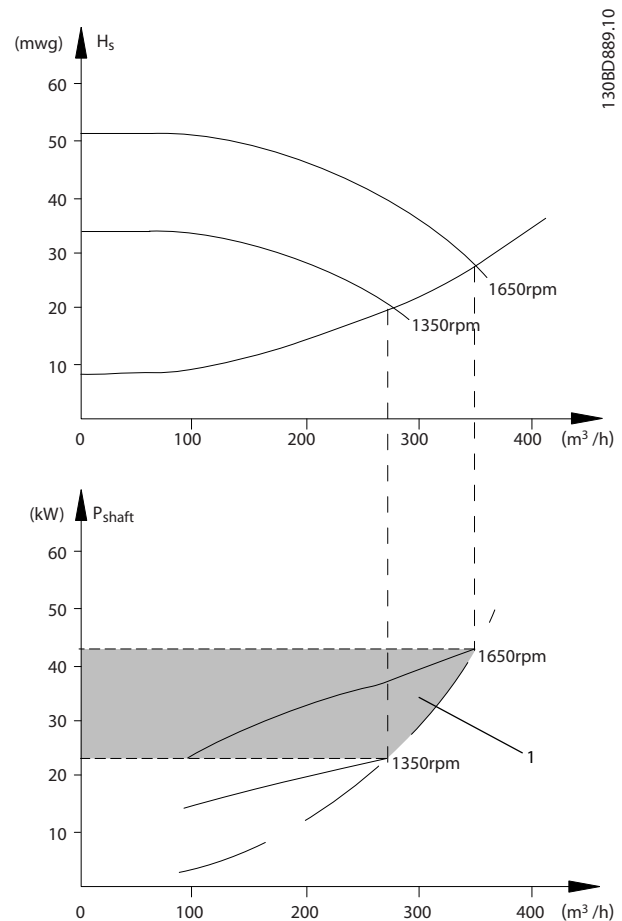

1	Energy saving
---	---------------

Illustration 2.1 Example: Energy Saving

2.1.3 Example of Energy Savings

As shown in *Illustration 2.2*, the flow is controlled by changing the pump speed, measured in RPM. By reducing the speed only 20% from the rated speed, the flow is also reduced by 20%. The flow is directly proportional to the speed. The consumption of electricity is reduced by up to 50%.

If the system only has to supply a flow that corresponds to 100% a few days in a year, while the average is below 80% of the rated flow for the remainder of the year, the energy savings are even greater than 50%.

Illustration 2.2 describes the dependence of flow, pressure, and power consumption on pump speed in RPM for centrifugal pumps.

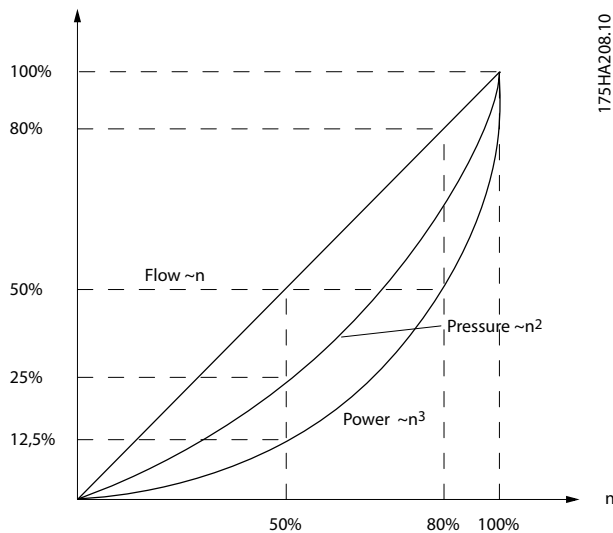

Illustration 2.2 Affinity Laws for Centrifugal Pumps

$$\text{Flow : } \frac{Q_1}{Q_2} = \frac{n_1}{n_2}$$

$$\text{Pressure : } \frac{H_1}{H_2} = \left(\frac{n_1}{n_2}\right)^2$$

$$\text{Power : } \frac{P_1}{P_2} = \left(\frac{n_1}{n_2}\right)^3$$

Assuming an equal efficiency in the speed range.

Q=Flow	P=Power
Q ₁ =Flow 1	P ₁ =Power 1
Q ₂ =Reduced flow	P ₂ =Reduced power
H=Pressure	n=Speed regulation
H ₁ =Pressure 1	n ₁ =Speed 1
H ₂ =Reduced pressure	n ₂ =Reduced speed

Table 2.1 Affinity Laws

2.1.4 Example with Varying Flow over 1 Year

This example is calculated based on pump characteristics obtained from a pump datasheet, shown in *Illustration 2.4*.

The result obtained shows energy savings in excess of 50% at the given flow distribution over a year, see *Illustration 2.3*. The payback period depends on the price of electricity and the price of the frequency converter. In this example, payback is less than a year, when compared with valves and constant speed.

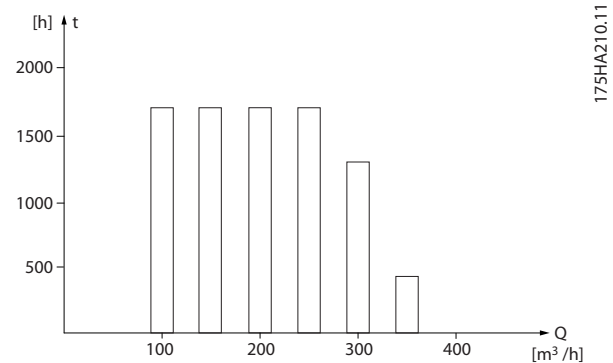

t [h]	Duration of flow. See also <i>Table 2.2</i> .
Q [m³/h]	Flowrate

Illustration 2.3 Flow Distribution over 1 Year (Duration versus Flowrate)

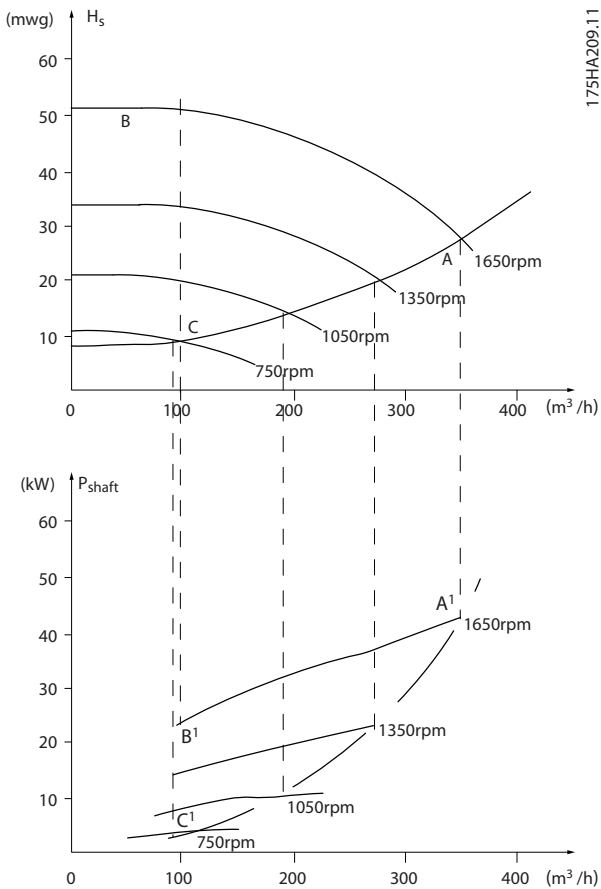

Illustration 2.4 Energy Consumption at Different Speeds

Flow rate	Distribution		Valve regulation		Frequency converter control	
	%	Duration	Power	Consumption	Power	Consumption
[m³/h]		[h]	[kW]	[kWh]	[kW]	[kWh]
350	5	438	42.5 ¹⁾	18.615	42.5 ¹⁾	18.615
300	15	1314	38.5	50.589	29.0	38.106
250	20	1752	35.0	61.320	18.5	32.412
200	20	1752	31.5	55.188	11.5	20.148
150	20	1752	28.0	49.056	6.5	11.388
100	20	1752	23.0 ²⁾	40.296	3.5 ³⁾	6.132
Σ	10	8760	-	275.064	-	26.801
	0					

Table 2.2 Result

- 1) Power reading at point A1.
- 2) Power reading at point B1.
- 3) Power reading at point C1.

2.1.5 Improved Control

Use a frequency converter to improve control of the flow or pressure of a system.
 Use a frequency converter to vary the speed of the compressor, fan, or pump, obtaining variable control of flow and pressure.
 Furthermore, a frequency converter can quickly adapt the speed of the compressor, fan, or pump to new flow or pressure conditions in the system.
 Obtain simple control of process (flow, level, or pressure) utilising the built-in PI control.

2.1.6 Star/Delta Starter or Soft Starter

When large motors are started, it is necessary in many countries to use equipment that limits the start-up current. In more traditional systems, a star/delta starter or soft starter is widely used. If a frequency converter is used, such motor starters are not required.

As illustrated in *Illustration 2.5*, a frequency converter does not consume more than rated current.

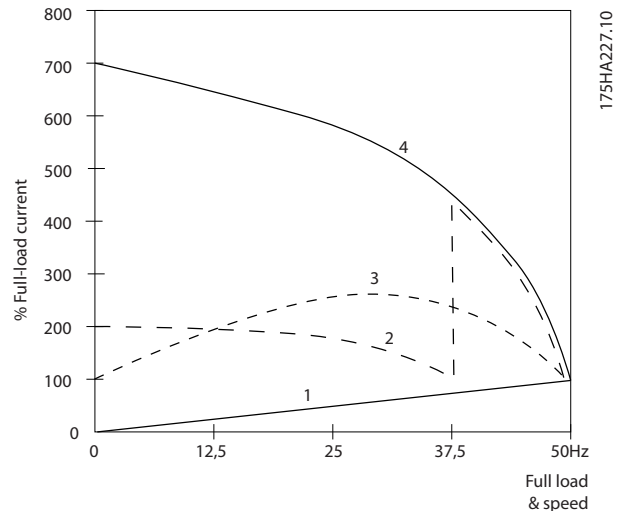

1	VLT® Refrigeration Drive FC 103
2	Star/delta starter
3	Soft starter
4	Start directly on mains

Illustration 2.5 Start-up Current

2.2 Description of Operation

The frequency converter supplies a regulated amount of mains AC power to the motor to control its speed. The frequency converter supplies variable frequency and voltage to the motor.

The frequency converter is divided into 4 main modules:

- Rectifier
- Intermediate DC bus circuit
- Inverter
- Control and regulation

Illustration 2.6 is a block diagram of the internal components of the frequency converter.

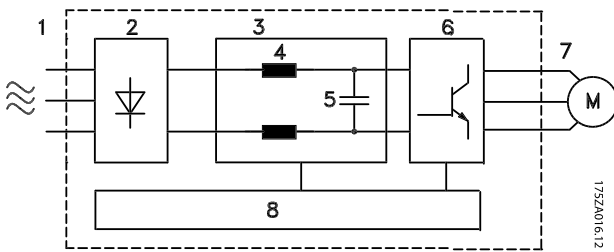

Area	Title	Functions
1	Mains input	<ul style="list-style-type: none"> • 3-phase AC mains supply to the frequency converter.
2	Rectifier	<ul style="list-style-type: none"> • The rectifier bridge converts the AC input to DC current to supply inverter power.
3	DC bus	<ul style="list-style-type: none"> • Intermediate DC bus circuit handles the DC current.
4	DC reactors	<ul style="list-style-type: none"> • Filter the intermediate DC circuit voltage. • Provide mains transient protection. • Reduce RMS current. • Raise the power factor reflected back to the line. • Reduce harmonics on the AC input.
5	Capacitor bank	<ul style="list-style-type: none"> • Stores the DC power. • Provides ride-through protection for short power losses.
6	Inverter	<ul style="list-style-type: none"> • Converts the DC into a controlled PWM AC waveform for a controlled variable output to the motor.
7	Output to motor	<ul style="list-style-type: none"> • Regulated 3-phase output power to the motor.

Area	Title	Functions
8	Control circuitry	<ul style="list-style-type: none"> • Input power, internal processing, output, and motor current are monitored to provide efficient operation and control. • User interface and external commands are monitored and performed. • Status output and control can be provided.

Illustration 2.6 Frequency Converter Block Diagram

2

2.2.1 Control Structure Principle

- The frequency converter rectifies AC voltage from mains into DC voltage.
- The DC voltage is converted into an AC current with a variable amplitude and frequency.

The frequency converter supplies the motor with variable voltage/current and frequency, which enables variable

speed control of 3-phased, standard asynchronous motors and non-salient PM motors.

The frequency converter manages various motor control principles such as U/f special motor mode and VVC+. Short-circuit behaviour of the frequency converter depends on the 3 current transducers in the motor phases.

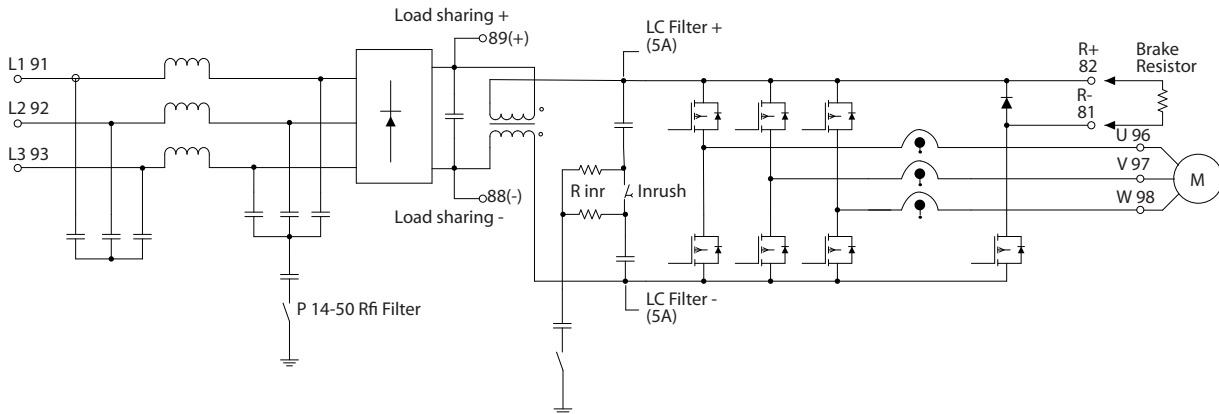

Illustration 2.7 Frequency Converter Structure

2.3 Sequence of Operation

2.3.1 Rectifier Section

When power is applied to the frequency converter, it enters through the mains terminals (L1, L2, and L3). Depending on the unit configuration, the power moves on to the disconnect and/or RFI filter option.

2.3.2 Intermediate Section

Following the rectifier section, voltage passes to the intermediate section. A filter circuit consisting of the DC bus inductor and the DC bus capacitor bank smoothes the rectified voltage.

The DC bus inductor provides series impedance to changing current. This aids the filtering process while reducing harmonic distortion to the input AC current waveform normally inherent in rectifier circuits.

2.3.3 Inverter Section

In the inverter section, once a run command and speed reference are present, the IGBTs begin switching to create the output waveform. This waveform, as generated by the Danfoss VVC+ PWM principle at the control card, provides optimal performance and minimal losses in the motor.

2.4 Control Structures

2.4.1 Control Structure Open Loop

When operating in open-loop mode, the frequency converter responds to input commands manually via the LCP keys or remotely via the analog/digital inputs or serial bus.

In the configuration shown in *Illustration 2.8*, the frequency converter operates in open-loop mode. It receives input

from either the LCP (*Hand mode*) or via a remote signal (*Auto mode*). The signal (speed reference) is received and conditioned with the following:

- Programmed minimum and maximum motor speed limits (in RPM and Hz).
- Ramp-up and ramp-down times.
- Motor rotation direction.

The reference is then passed on to control the motor.

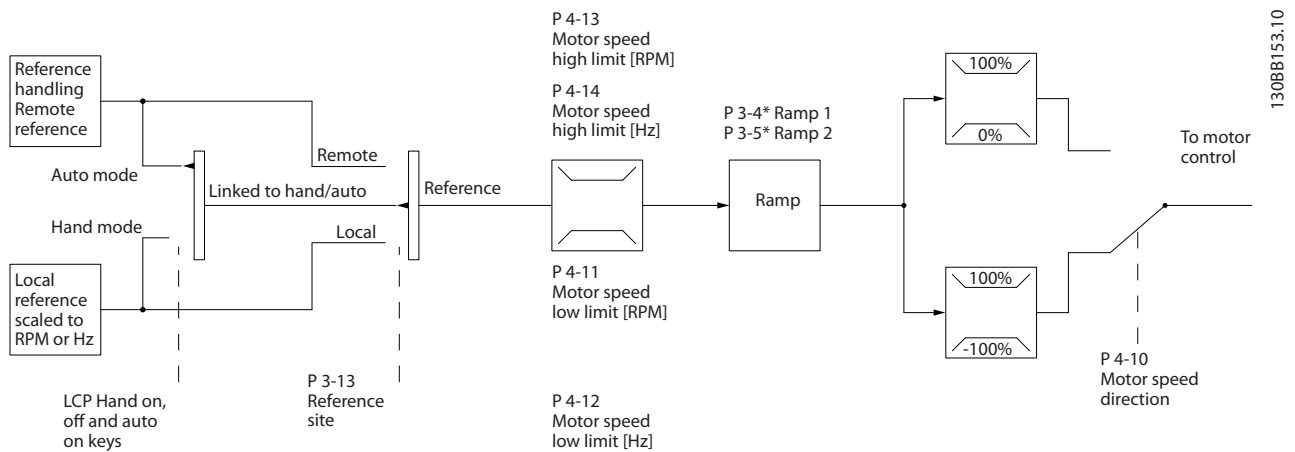

Illustration 2.8 Block Diagram of Open-loop Mode

2.4.2 Control Structure Closed Loop

In closed-loop mode, an internal PID controller allows the frequency converter to process system reference and feedback signals to act as an independent control unit. The

frequency converter can provide status and alarm messages, along with many other programmable options, for external system monitoring while operating independently in closed loop.

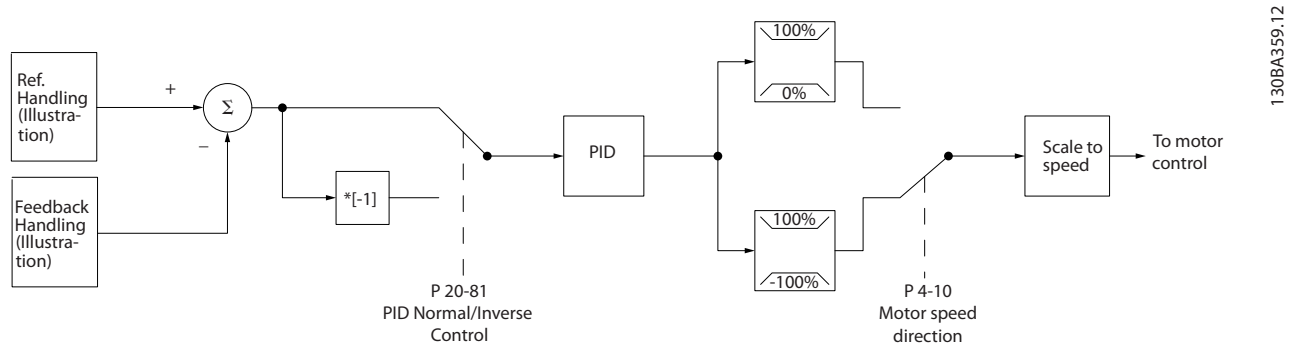

Illustration 2.9 Block Diagram of Closed-loop Controller

For example, consider a pump application in which the speed of a pump is controlled so that the static pressure in a pipe is constant (see *Illustration 2.9*). The frequency converter receives a feedback signal from a sensor in the system. It compares this feedback to a setpoint reference value and determines the error, if any, between these 2

signals. It then adjusts the speed of the motor to correct this error.

The static pressure setpoint is the reference signal to the frequency converter. A static pressure sensor measures the actual static pressure in the pipe and provides this

information to the frequency converter as a feedback signal. If the feedback signal exceeds the setpoint reference, the frequency converter ramps down to reduce the pressure. Similarly, if the pipe pressure is lower than the setpoint reference, the frequency converter ramps up to increase the pump pressure.

While the default values for the frequency converter in closed loop often provide satisfactory performance, system control can often be optimised by tuning the PID parameters. *Auto tuning* is provided for this optimisation.

Other programmable features include:

- Inverse regulation - motor speed increases when a feedback signal is high. This is useful in compressor applications, where speed needs to be increased if the pressure/temperature is too high.
- Start-up frequency - lets the system quickly reach an operating status before the PID controller takes over.
- Built-in lowpass filter - reduces feedback signal noise.

2.4.3 Local (Hand On) and Remote (Auto On) Control

Operate the frequency converter manually via the LCP, or remotely via analog and digital inputs, and serial bus.

Active reference and configuration mode

The active reference is either a local reference or a remote reference. Remote reference is the default setting.

- To use the local reference, configure in *Hand* mode. To enable *Hand* mode, adapt parameter settings in parameter group *0-4* LCP Keypad*. For more information, refer to the *programming guide*.
- To use the remote reference, configure in *Auto* mode, which is the default mode. In *Auto* mode, it is possible to control the frequency converter via the digital inputs and various serial interfaces (RS485, USB, or an optional fieldbus).
- *Illustration 2.10* shows the configuration mode resulting from active reference selection, either local or remote.
- *Illustration 2.11* shows manual configuration mode for local reference.

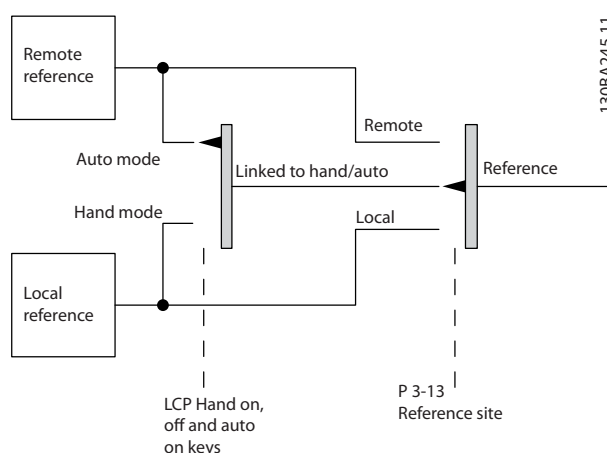

Illustration 2.10 Active Reference

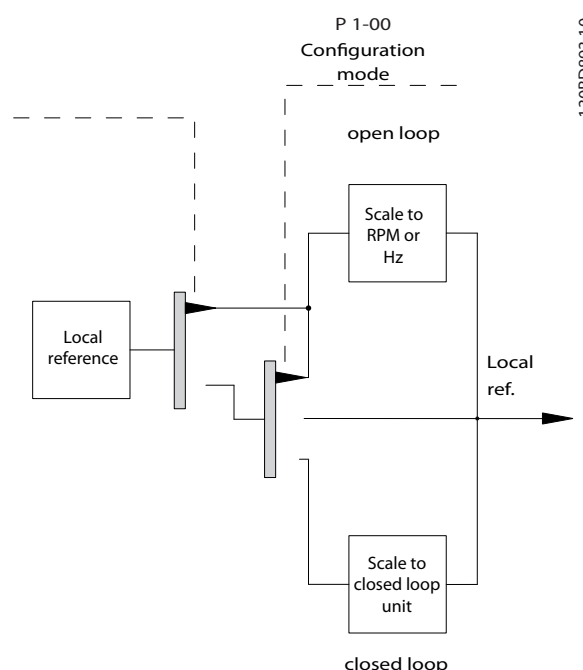

Illustration 2.11 Manual Configuration Mode

Application control principle

Either the remote reference or the local reference is active at any time. Both cannot be active simultaneously. Set the application control principle (that is, open loop or closed loop) in *parameter 1-00 Configuration Mode*, as shown in *Table 2.3*.

When the local reference is active, set the application control principle in *parameter 1-05 Local Mode Configuration*.

Set the reference site in *parameter 3-13 Reference Site*, as shown in *Table 2.3*.

For more information, refer to the *programming guide*.

[Hand On] [Auto On] LCP Keys	Parameter 3-13 Reference Site	Active Reference
Hand	Linked to Hand/Auto	Local
Hand⇒Off	Linked to Hand/Auto	Local
Auto	Linked to Hand/Auto	Remote
Auto⇒Off	Linked to Hand/Auto	Remote
All keys	Local	Local
All keys	Remote	Remote

Table 2.3 Local and Remote Reference Configurations

2.4.4 Reference Handling

Reference handling is applicable in both open- and closed-loop operation.

Internal and external references

Up to 8 internal preset references can be programmed into the frequency converter. The active internal preset reference can be selected externally through digital control inputs or the serial communications bus.

External references can also be supplied to the frequency converter, most commonly through an analog control input. All reference sources and the bus reference are added to produce the total external reference. As active reference select one of the following:

- The external reference
- The preset reference
- The setpoint
- The sum of all the above 3

The active reference can be scaled.

The scaled reference is calculated as follows:

$$\text{Reference} = X + X \times \left(\frac{Y}{100} \right)$$

Where X is the external reference, the preset reference, or the sum of these references, and Y is *parameter 3-14 Preset Relative Reference* in [%].

If Y, *parameter 3-14 Preset Relative Reference*, is set to 0%, the scaling does not affect the reference.

Remote reference

A remote reference is comprised of the following (see *Illustration 2.12*):

- Preset references
- External references:
 - Analog inputs
 - Pulse frequency inputs
 - Digital potentiometer inputs
 - Serial communication bus references
- A preset relative reference
- A feedback controlled setpoint

2

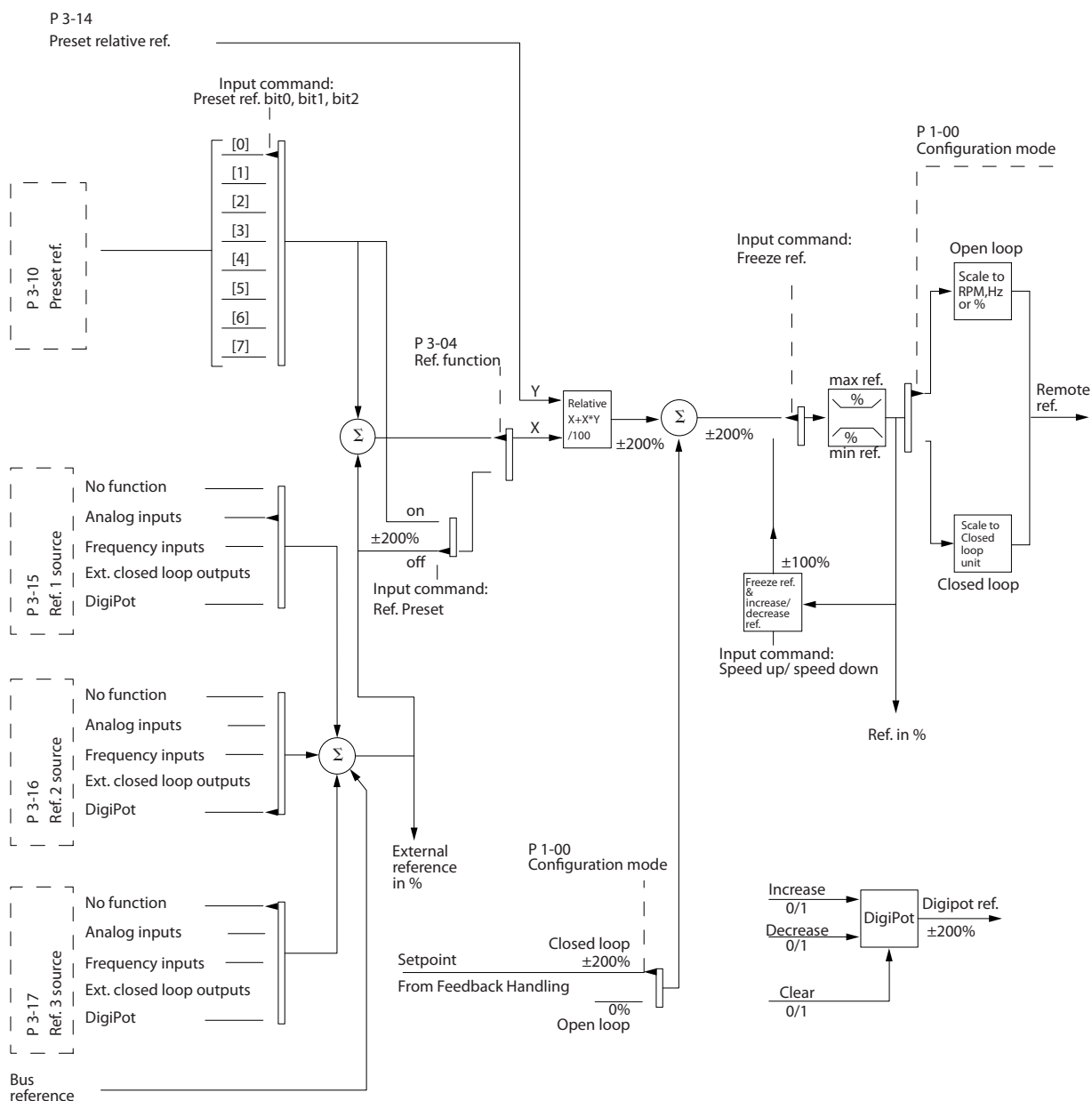

130BA357.12

Illustration 2.12 Remote Reference Handling

2.4.5 Feedback Handling

Feedback handling can be configured to work with applications requiring advanced control, such as multiple setpoints and multiple types of feedback (see *Illustration 2.13*).

3 types of control are common:

Single zone, single setpoint

This control type is a basic feedback configuration. Setpoint 1 is added to any other reference (if any) and the feedback signal is selected.

Multi-zone, single setpoint

This control type uses 2 or 3 feedback sensors but only 1 setpoint. The feedback can be added, subtracted, or averaged. In addition, the maximum or minimum value can be used. Setpoint 1 is used exclusively in this configuration.

Multi-zone, setpoint/feedback

The setpoint/feedback pair with the largest difference controls the speed of the frequency converter. The maximum attempts to keep all zones at or below their respective setpoints, while minimum attempts to keep all zones at or above their respective setpoints.

Example

A 2-zone, 2-setpoint application. Zone 1 setpoint is 15 bar, and the feedback is 5.5 bar. Zone 2 setpoint is 4.4 bar, and the feedback is 4.6 bar. If maximum is selected, the zone 2 setpoint and feedback are sent to the PID controller, since it has the smaller difference (feedback is higher than setpoint, resulting in a negative difference). If minimum is selected, the zone 1 setpoint and feedback is sent to the PID controller, since it has the larger difference (feedback is lower than setpoint, resulting in a positive difference).

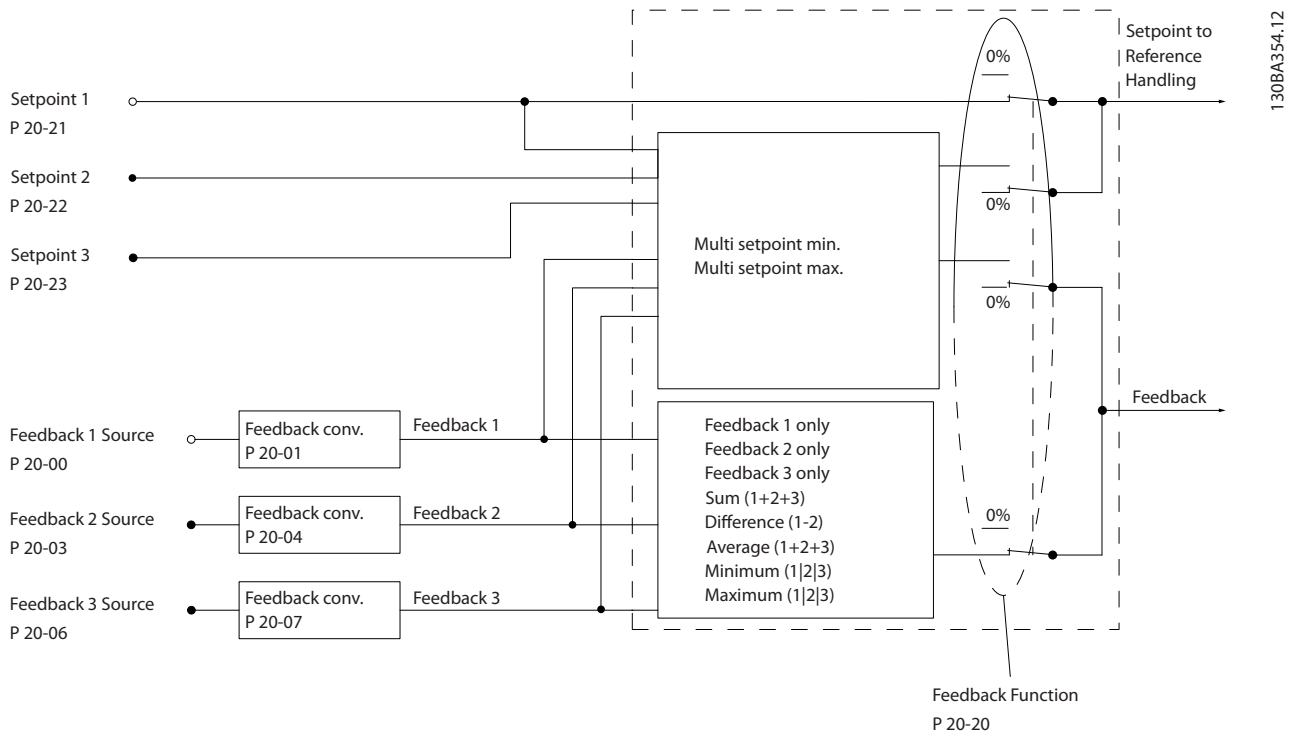

Illustration 2.13 Block Diagram of Feedback Signal Processing

Feedback conversion

In some applications, it is useful to convert the feedback signal. One example is using a pressure signal to provide flow feedback. Since the square root of pressure is proportional to flow, the square root of the pressure signal yields a value proportional to the flow, see *Illustration 2.14*.

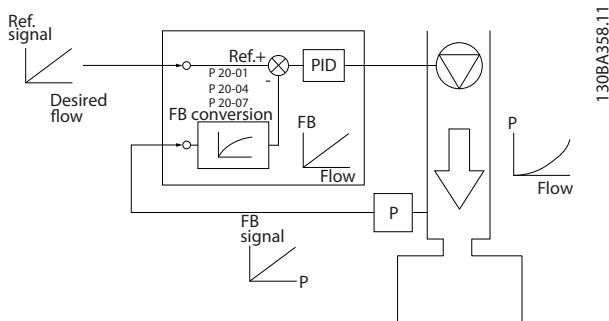

Illustration 2.14 Feedback Conversion

2.5 Automated Operational Functions

Automated operational features are active as soon as the frequency converter is operating. Most of them require no programming or set-up. Understanding that these features are present can optimise a system design and possibly avoid introducing redundant components or functionality.

For details of any set-up required, in particular motor parameters, refer to the *programming guide*.

The frequency converter has a range of built-in protection functions to protect itself and the motor when it runs.

2.5.1 Short-circuit Protection

Motor (phase-phase)

The frequency converter is protected against short circuits on the motor side by current measurement in each of the motor phases or in the DC link. A short circuit between 2 output phases causes an overcurrent in the inverter. The inverter is turned off when the short-circuit current exceeds the permitted value (*Alarm 16, Trip Lock*).

Mains side

A frequency converter that works correctly limits the current it can draw from the supply. Use fuses and/or circuit breakers on the supply side as protection in case of component break-down inside the frequency converter (first fault). See *chapter 7.8 Fuses and Circuit Breakers* for more information.

NOTICE

To ensure compliance with IEC 60364 for CE or NEC 2009 for UL, it is mandatory to use fuses and/or circuit breakers.

2.5.2 Overvoltage Protection

Motor-generated overvoltage

When the motor acts as a generator, the voltage in the DC link increases. This behaviour occurs in the following cases:

- The load drives the motor (at constant output frequency from the frequency converter), for example, the load generates energy.
- During deceleration (ramp down) with high inertia moment, low friction, and a too short ramp-down time for the energy to be dissipated as a loss in the frequency converter, the motor, and the installation.
- Incorrect slip compensation setting may cause higher DC-link voltage.
- Back EMF from PM motor operation. If coasted at high RPM, the PM motor back EMF may potentially exceed the maximum voltage tolerance of the frequency converter and cause damage. To prevent this situation, the value of *parameter 4-19 Max Output Frequency* is automatically limited via an internal calculation based on the value of *parameter 1-40 Back EMF at 1000 RPM*, *parameter 1-25 Motor Nominal Speed*, and *parameter 1-39 Motor Poles*.

NOTICE

To avoid motor overspeeding (for example due to excessive windmilling effects or uncontrolled water flow), equip the frequency converter with a brake resistor.

Handle the overvoltage by either using a brake function (*parameter 2-10 Brake Function*) or using overvoltage control (*parameter 2-17 Over-voltage Control*).

Overvoltage control (OVC)

OVC reduces the risk of the frequency converter tripping due to an overvoltage on the DC-link. This is managed by automatically extending the ramp-down time.

NOTICE

OVC can be activated for PM motors (PM VVC+).

2.5.3 Missing Motor Phase Detection

The missing motor phase function (*parameter 4-58 Missing Motor Phase Function*) is enabled by default to avoid motor damage in the case that a motor phase is missing. The default setting is 1000 ms, but it can be adjusted for a faster detection.

2.5.4 Mains Phase Imbalance Detection

Operation under severe mains imbalance conditions reduces the lifetime of the motor. If the motor is operated continuously near nominal load, conditions are considered severe. The default setting trips the frequency converter in case of mains imbalance (*parameter 14-12 Function at Mains Imbalance*).

2.5.5 Switching on the Output

Adding a switch to the output between the motor and the frequency converter is permitted. Fault messages may appear. To catch a spinning motor, enable flying start.

2.5.6 Overload Protection

Torque limit

The torque limit feature protects the motor against overload, independent of the speed. Torque limit is controlled in *parameter 4-16 Torque Limit Motor Mode* or *parameter 4-17 Torque Limit Generator Mode*, and the time before the torque limit warning trips is controlled in *parameter 14-25 Trip Delay at Torque Limit*.

Current limit

The current limit is controlled in *parameter 4-18 Current Limit*.

Speed limit

Define lower and upper limits for the operating speed range using 1 or more of the following parameters:

- *Parameter 4-11 Motor Speed Low Limit [RPM]*.
- *Parameter 4-12 Motor Speed Low Limit [Hz]* and *parameter 4-13 Motor Speed High Limit [RPM]*.
- *Parameter 4-14 Motor Speed High Limit [Hz]*.

For example, the operating speed range can be defined as between 30 and 50/60 Hz.

Parameter 4-19 Max Output Frequency limits the maximum output speed the frequency converter can provide.

ETR

ETR is an electronic feature that simulates a bimetal relay based on internal measurements. The characteristic is shown in *Illustration 2.15*.

Voltage limit

When a certain hard-coded voltage level is reached, the frequency converter turns off to protect the transistors and the DC link capacitors.

Overtemperature

The frequency converter has built-in temperature sensors and reacts immediately to critical values via hard-coded limits.

2.5.7 Automatic Derating

The frequency converter constantly checks for critical levels:

- High temperature on the control card or heat sink
- High motor load
- High DC-link voltage
- Low motor speed

As a response to a critical level, the frequency converter adjusts the switching frequency. For high internal temperatures and low motor speed, the frequency converters can also force the PWM pattern to SFAVM.

NOTICE

The automatic derating is different when *parameter 14-55 Output Filter* is set to [2] *Sine-Wave Filter Fixed*.

2.5.8 Automatic Energy Optimisation

Automatic energy optimisation (AEO) directs the frequency converter to monitor the load on the motor continuously and adjust the output voltage to maximise efficiency. Under light load, the voltage is reduced and the motor current is minimised. The motor benefits from:

- Increased efficiency.
- Reduced heating.
- Quieter operation.

There is no need to select a V/Hz curve because the frequency converter automatically adjusts motor voltage.

2.5.9 Automatic Switching Frequency Modulation

The frequency converter generates short electrical pulses to form an AC wave pattern. The switching frequency is the rate of these pulses. A low switching frequency (slow pulsing rate) causes audible noise in the motor, making a higher switching frequency preferable. A high switching frequency, however, generates heat in the frequency converter which can limit the amount of current available to the motor.

Automatic switching frequency modulation regulates these conditions automatically to provide the highest switching frequency without overheating the frequency converter. By providing a regulated high switching frequency, it quiets motor operating noise at slow speeds, when audible noise control is critical, and produces full output power to the motor when required.

2.5.10 Automatic Derating for High Switching Frequency

The frequency converter is designed for continuous, full-load operation at switching frequencies between 3.0 and 4.5 kHz (this frequency range depends on power size). A switching frequency exceeding the maximum permissible range generates increased heat in the frequency converter and requires the output current to be derated.

An automatic feature of the frequency converter is load-dependent switching frequency control. This feature allows the motor to benefit from as high a switching frequency as the load allow.

2.5.11 Automatic Derating for Overtemperature

Automatic overtemperature derating works to prevent tripping the frequency converter at high temperature. Internal temperature sensors measure conditions to protect the power components from overheating. The frequency converter can automatically reduce the switching frequency to maintain the operating temperature within safe limits. After reducing the switching frequency, the frequency converter can also reduce the output frequency and current by as much as 30% to avoid an overtemperature trip.

2.5.12 Auto Ramping

A motor trying to accelerate a load too quickly for the current available can cause the frequency converter to trip. The same is true for too quick a deceleration. Auto ramping protects against these situations by extending the motor ramping rate (acceleration or deceleration) to match the available current.

2.5.13 Current Limit Circuit

When a load exceeds the current capability of the frequency converter normal operation (from an undersized frequency converter or motor), current limit reduces the output frequency to ramp down the motor and reduce the load. An adjustable timer is available to limit operation in this condition for 60 s or less. The factory default limit is 110% of the rated motor current to minimise overcurrent stress.

2.5.14 Power Fluctuation Performance

The frequency converter withstands mains fluctuations such as:

- Transients.
- Momentary drop-outs.
- Short voltage drops.
- Surges.

The frequency converter automatically compensates for input voltages $\pm 10\%$ from the nominal to provide full rated motor voltage and torque. With auto restart selected, the frequency converter automatically powers up after a voltage trip. With flying start, the frequency converter synchronises to motor rotation before start.

2.5.15 Motor Soft Start

The frequency converter supplies the right amount of current to the motor to overcome load inertia and bring the motor up to speed. This avoids full mains voltage being applied to a stationary or slow-turning motor, which generates high current and heat. This inherent soft start feature reduces thermal load and mechanical stress, extends motor life, and provides quieter system operation.

2.5.16 Resonance Damping

Eliminate high frequency motor resonance noise through resonance damping. Automatic or manually selected frequency damping is available.

2.5.17 Temperature-controlled Fans

Sensors in the frequency converter control the temperature of the internal cooling fans. Often, the cooling fans do not run during low load operation, or when in sleep mode or standby. This reduces noise, increases efficiency, and extends the operating life of the fan.

2.5.18 EMC Compliance

Electromagnetic interference (EMI) or radio frequency interference (RFI, in case of radio frequency) is disturbance that can affect an electrical circuit due to electromagnetic induction or radiation from an external source. The frequency converter is designed to comply with the EMC product standard for frequency converters IEC 61800-3 as well as the European standard EN 55011. To comply with the emission levels in EN 55011, screen and terminate the motor cable properly terminated. For more information regarding EMC performance, see *chapter 3.2.2 EMC Test Results (Emission)*.

2.5.19 Current Measurement on All Three Motor Phases

Output current to the motor is continuously measured on all 3 phases to protect the frequency converter and motor against short circuits, ground faults, and phase loss. Output ground faults are instantly detected. If a motor phase is lost, the frequency converter stops immediately and reports which phase is missing.

2.5.20 Galvanic Isolation of Control Terminals

All control terminals and output relay terminals are galvanically isolated from mains power. This means the controller circuitry is completely protected from the input current. The output relay terminals require their own grounding. This isolation meets the stringent protective extra-low voltage (PELV) requirements for isolation.

The components that make up the galvanic isolation are:

- Power supply, including signal isolation.
- Gate drive for the IGBTs, trigger transformers, and optocouplers.
- The output current Hall effect transducers.

2.6 Custom Application Functions

Custom application functions are the most common features programmed in the frequency converter for enhanced system performance. They require minimum programming or set-up. Understanding that these functions are available can optimise the system design and possibly avoid introducing redundant components or functionality. See the *programming guide* for instructions on activating these functions.

2.6.1 Automatic Motor Adaptation

Automatic motor adaptation (AMA) is an automated test procedure used to measure the electrical characteristics of the motor. AMA provides an accurate electronic model of the motor. It allows the frequency converter to calculate optimal performance and efficiency with the motor. Running the AMA procedure also maximises the automatic energy optimisation feature of the frequency converter. AMA is performed without the motor rotating and without uncoupling the load from the motor.

2.6.2 Motor Thermal Protection

Motor thermal protection can be provided in 3 ways:

- Via direct temperature sensing via the PTC sensor in the motor windings and connected on a standard AI or DI.
- Mechanical thermal switch (Klixon type) on a DI.
- Via the built-in electronic thermal relay (ETR) for asynchronous motors.

ETR calculates motor temperature by measuring current, frequency, and operating time. The frequency converter shows the thermal load on the motor in percentage and can issue a warning at a programmable overload setpoint. Programmable options at the overload allow the frequency converter to stop the motor, reduce output, or ignore the condition. Even at low speeds, the frequency converter meets I2t Class 20 electronic motor overload standards.

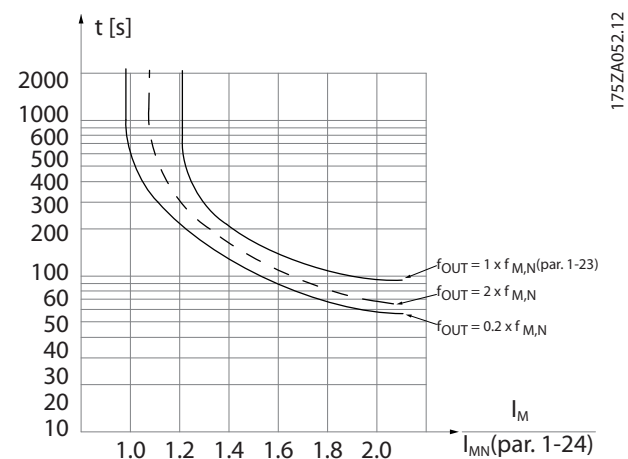

Illustration 2.15 ETR Characteristics

The X-axis in *Illustration 2.15* shows the ratio between I_{motor} and I_{motor} nominal. The Y-axis shows the time in seconds before the ETR cuts off and trips the frequency converter. The curves show the characteristic nominal speed, at twice the nominal speed and at 0.2 x the nominal speed. At lower speed, the ETR cuts off at lower heat due to less cooling of the motor. In that way, the motor is protected from being overheated even at low speed. The ETR feature calculates the motor temperature based on actual current and speed. The calculated temperature is visible as a readout parameter in *parameter 16-18 Motor Thermal*.

2.6.3 Mains Drop-out

During a mains drop-out, the frequency converter keeps running until the DC-link voltage drops below the minimum stop level. The minimum stop level is typically 15% below the lowest rated supply voltage. The mains

voltage before the drop-out and the motor load determines how long it takes for the frequency converter to coast.

Configure the frequency converter (*parameter 14-10 Mains Failure*) to different types of behaviour during mains drop-out,

- Trip lock once the DC link is exhausted.
- Coast with flying start whenever mains return (*parameter 1-73 Flying Start*).
- Kinetic back-up.
- Controlled ramp down.

Flying start

This selection makes it possible to catch a motor that spins freely due to a mains drop-out. This option is relevant for centrifuges and fans.

Kinetic back-up

This selection ensures that the frequency converter runs as long as there is energy in the system. For short mains drop-out, the operation is restored after mains return, without bringing the application to a stop or losing control at any time. Several variants of kinetic back-up can be selected.

Configure the behaviour of the frequency converter at mains drop-out, in *parameter 14-10 Mains Failure* and *parameter 1-73 Flying Start*.

NOTICE

Coast is recommended for compressors as the inertia is too small for flying start in most situations.

2.6.4 Built-in PID Controllers

The 4 built-in proportional, integral, derivative (PID) controllers eliminate the need for auxiliary control devices.

One of the PID controllers maintains constant control of closed-loop systems where regulated pressure, flow, temperature, or other system requirements are maintained. The frequency converter can provide self-reliant control of the motor speed in response to feedback signals from remote sensors. The frequency converter accommodates 2 feedback signals from 2 different devices. This feature allows regulating a system with different feedback requirements. The frequency converter makes control decisions by comparing the 2 signals to optimise system performance.

Use the 3 additional and independent controllers for controlling other process equipment, such as chemical feed pumps, valve control, or for aeration with different levels.

2.6.5 Automatic Restart

The frequency converter can be programmed to restart the motor automatically after a minor trip, such as momentary power loss or fluctuation. This feature eliminates the need for manual resetting and enhances automated operation for remotely controlled systems. The number of restart attempts as well as the duration between attempts can be limited.

2.6.6 Flying Start

Flying start allows the frequency converter to synchronise with an operating motor rotating at up to full speed, in either direction. This prevents trips due to overcurrent draw. It minimises mechanical stress to the system since the motor receives no abrupt change in speed when the frequency converter starts.

2.6.7 Full Torque at Reduced Speed

The frequency converter follows a variable V/Hz curve to provide full motor torque even at reduced speeds. Full output torque can coincide with the maximum designed operating speed of the motor. This differs from variable torque frequency converters and constant torque frequency converters. Variable torque frequency converters provide reduced motor torque at low speed. Constant torque frequency converters provide excess voltage, heat, and motor noise at less than full speed.

2.6.8 Frequency Bypass

In some applications, the system may have operational speeds that create a mechanical resonance. This can generate excessive noise and possibly damage mechanical components in the system. The frequency converter has 4 programmable bypass-frequency bandwidths. These allow the motor to step over speeds that induce system resonance.

2.6.9 Motor Preheat

To preheat a motor in a cold or damp environment, a small amount of DC current can be trickled continuously into the motor to protect it from condensation and cold starts. This can eliminate the need for a space heater.

2.6.10 Four Programmable Set-ups

The frequency converter has 4 set-ups that can be independently programmed. Using multi-setup, it is possible to switch between independently programmed functions activated by digital inputs or a serial command. Independent set-ups are used, for example, to change references, or for day/night or summer/winter operation, or to control multiple motors. The LCP shows the active set-up.

Set-up data can be copied from frequency converter to frequency converter by downloading the information from the removable LCP.

2.6.11 DC Braking

Some applications may require braking a motor to slow or stopping it. Applying DC current to the motor brakes the motor and eliminates the need for a separate motor brake. DC brake can be set to activate at a predetermined frequency or after receiving a signal. The rate of braking can also be programmed.

2.6.12 Sleep Mode

Sleep mode automatically stops the motor when demand is low for a specified time. When the system demand increases, the frequency converter restarts the motor. Sleep mode provides energy savings and reduces motor wear. Unlike a setback clock, the frequency converter is always available to run when the preset wake-up demand is reached.

2.6.13 Run Permissive

The frequency converter can wait for a remote *system ready* signal before starting. When this feature is active, the frequency converter remains stopped until receiving permission to start. Run permissive ensures that the system or auxiliary equipment is in the proper state before the frequency converter is allowed to start the motor.

2.6.14 Smart Logic Control (SLC)

Smart logic control (SLC) is a sequence of user-defined actions (see *parameter 13-52 SL Controller Action [x]*) executed by the SLC when the associated user-defined event (see *parameter 13-51 SL Controller Event [x]*) is evaluated as TRUE by the SLC.

The condition for an event can be a particular status or that the output from a logic rule or a comparator operand becomes TRUE. That leads to an associated action as shown in *Illustration 2.16*.

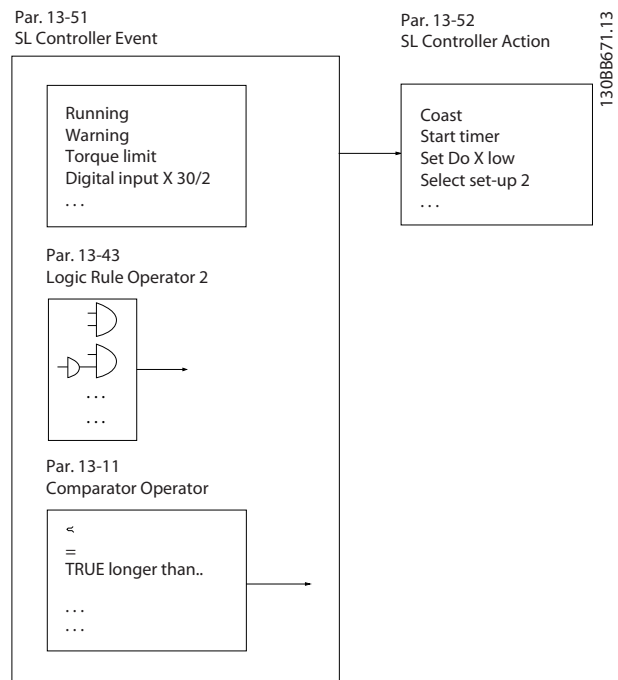

Illustration 2.16 SLC Event and Action

Events and actions are each numbered and linked in pairs (states). This means that when event [0] is fulfilled (attains the value TRUE), action [0] is executed. After this, the conditions of event [1] is evaluated and if evaluated TRUE, action [1] is executed and so on. Only one event is evaluated at any time. If an event is evaluated as FALSE, nothing happens (in the SLC) during the current scan interval and no other events are evaluated. This means that when the SLC starts, it evaluates event [0] (and only event [0]) each scan interval. Only when event [0] is evaluated TRUE, the SLC executes action [0] and starts evaluating event [1]. It is possible to programme from 1 to 20 events and actions.

When the last event/action has been executed, the sequence starts over again from event [0]/action [0].

Illustration 2.17 shows an example with 4 event/actions:

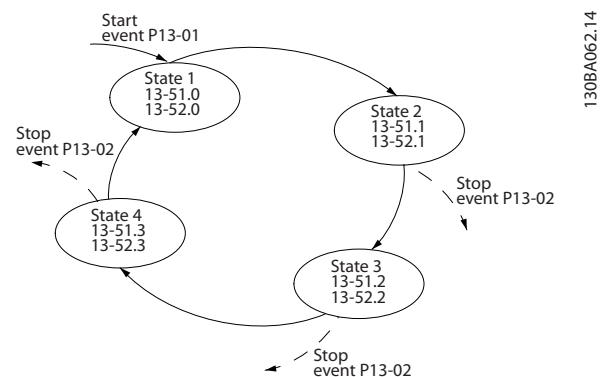

Illustration 2.17 Order of Execution when 4 Events/Actions are Programmed

Comparators

Comparators are used for comparing continuous variables (output frequency, output current, analog input, and so on) to fixed preset values.

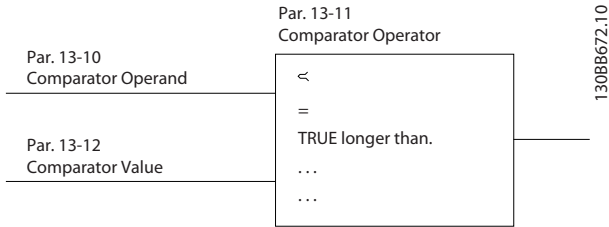

Illustration 2.18 Comparators

Logic rules

Combine up to 3 boolean inputs (TRUE/FALSE inputs) from timers, comparators, digital inputs, status bits, and events using the logical operators AND, OR, and NOT.

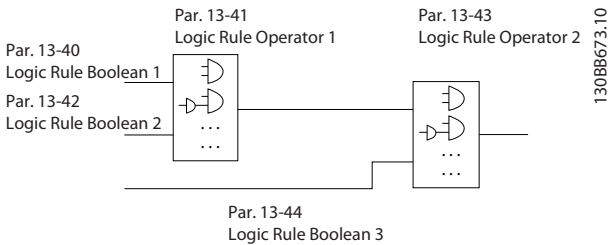

Illustration 2.19 Logic Rules

The logic rules, timers, and comparators are also available for use outside of the SLC sequence.

For an example of SLC, refer to *chapter 4.3 Application Set-up Examples*.

2.6.15 Safe Torque Off Function

The frequency converter is available with Safe Torque Off (STO) functionality via control terminal 37. STO disables the control voltage of the power semiconductors of the frequency converter output stage. This in turn prevents generating the voltage required to rotate the motor. When the STO (terminal 37) is activated, the frequency converter issues an alarm, trips the unit, and coasts the motor to a stop. Manual restart is required. The STO function can be used as an emergency stop for the frequency converter. In the normal operating mode when STO is not required, use the regular stop function. When using automatic restart, ensure the requirements of ISO 12100-2 paragraph 5.3.2.5 are fulfilled.

Liability conditions

It is the responsibility of the user to ensure personnel installing and operating the STO function:

- Read and understand the safety regulations concerning health, safety, and accident prevention.
- Have a good knowledge of the generic and safety standards applicable to the specific application.

A user is defined as:

- Integrator.
- Operator.
- Service technician.
- Maintenance technician.

Standards

Use of STO on terminal 37 requires that the user fulfills all provisions for safety including relevant laws, regulations, and guidelines. The optional STO function complies with the following standards:

- EN 954-1: 1996 Category 3
- IEC 60204-1: 2005 category 0 – uncontrolled stop
- IEC 61508: 1998 SIL2
- IEC 61800-5-2: 2007 – STO function
- IEC 62061: 2005 SIL CL2
- ISO 13849-1: 2006 Category 3 PL d
- ISO 14118: 2000 (EN 1037) – prevention of unexpected start-up

The listed information and instructions are not sufficient for a proper and safe use of the STO functionality. For full information about STO, refer to the *VLT® Safe Torque Off Operating Instructions*.

Protective measures

- Qualified and skilled personnel are required for installation and commissioning of safety engineering systems.
- Install the unit in an IP54 enclosure or in an equivalent environment. In special applications, a higher IP degree is required.
- The cable between terminal 37 and the external safety device must be short circuit protected according to ISO 13849-2 table D.4.
- When external forces influence the motor axis (for example, suspended loads), to eliminate potential hazards, additional measures are required (for example, a safety holding brake).

2.7 Fault, Warning and Alarm Functions

The frequency converter monitors many aspects of system operation including mains conditions, motor load, and performance, as well as frequency converter status. An alarm or warning does not necessarily indicate a problem with the frequency converter itself. It may be a condition outside of the frequency converter that is being monitored for performance limits. The frequency converter has various pre-programmed fault, warning, and alarm responses. Select additional alarm and warning features to enhance or modify system performance.

This section describes common alarm and warning features. Understanding that these features are available can optimise a system design and possibly avoid introducing redundant components or functionality.

2.7.1 Operation at Overtemperature

By default, the frequency converter issues an alarm and trip at overtemperature. If *Autoderate and Warning* is selected, the frequency converter warns of the condition but continues to run and attempt to cool itself by first reducing its switching frequency. Then, if necessary, it reduces the output frequency.

Autoderating does not replace the user settings for derating for ambient temperature (see *chapter 5.4 Derating for Ambient Temperature*).

2.7.2 High and Low Reference Warning

In open-loop operation, the reference signal directly determines the speed of the frequency converter. The display shows a flashing reference high or low warning when the programmed maximum or minimum is reached.

2.7.3 High and Low Feedback Warning

In closed-loop operation, the frequency converter monitors the selected high and low feedback values. The display shows a flashing high or flashing low warning when appropriate. The frequency converter can also monitor feedback signals in open-loop operation. While the signals do not affect the operation of the frequency converter in open loop, they can be useful for system status indication locally or via serial communication. The frequency converter handles 39 different units of measure.

2.7.4 Phase Imbalance or Phase Loss

Excessive ripple current in the DC bus indicates either a mains phase imbalance or a phase loss. When a power phase to the frequency converter is lost, the default action is to issue an alarm and trip the unit to protect the DC bus

capacitors. Other options are to issue a warning and reduce output current to 30% of full current or to issue a warning and continue normal operation. Operating a unit connected to an imbalanced line may be desirable until the imbalance is corrected.

2.7.5 High Frequency Warning

When staging on additional equipment such as compressors or cooling fans, the frequency converter can warn when the motor speed is high. A specific high frequency setting can be entered into the frequency converter. If the output exceeds the set warning frequency, the unit shows a high frequency warning. A digital output from the frequency converter can signal external devices to stage on.

2.7.6 Low Frequency Warning

When staging off equipment, the frequency converter can warn when the motor speed is low. A specific low frequency setting can be selected for warning and to stage off external devices. The unit does not issue a low frequency warning when it stops nor after start-up until after the operating frequency has been reached.

2.7.7 High Current Warning

This function is similar to high frequency warning, except a high current setting is used to issue a warning and stage on additional equipment. The function is not active when stopped or at start-up until the set operating current has been reached.

2.7.8 Low Current Warning

This function is similar to low frequency warning (see *chapter 2.7.6 Low Frequency Warning*), except a low current setting is used to issue a warning and stage off equipment. The function is not active when stopped or at start-up until the set operating current has been reached.

2.7.9 No Load/Broken Belt Warning

This feature can be used for monitoring a no-load condition, for example a V-belt. After a low current limit has been stored in the frequency converter, if loss of the load is detected, the frequency converter can be programmed to issue an alarm and trip or to continue operation and issue a warning.

2.7.10 Lost Serial Interface

The frequency converter can detect loss of serial communication. A time delay of up to 99 s is selectable to avoid a response due to interruptions on the serial communications bus. When the delay is exceeded, options available include for the unit to:

- Maintain its last speed.
- Go to maximum speed.
- Go to a preset speed.
- Stop and issue a warning.

2.8 User Interfaces and Programming

The frequency converter uses parameters for programming its application functions. Parameters provide a description of a function and a menu of options to either select from or for entering numeric values. A sample programming menu is shown in *Illustration 2.20*.

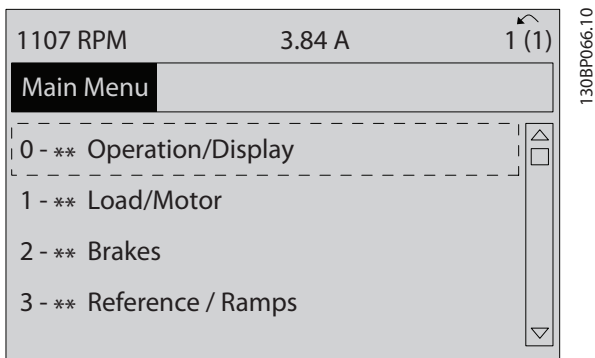

Illustration 2.20 Sample Programming Menu

Local user interface

For local programming, parameters are accessible by pressing either [Quick Menu] or [Main Menu] on the LCP.

The Quick Menu is intended for initial start-up and motor characteristics. The Main Menu accesses all parameters and allows for advanced applications programming.

Remote user interface

For remote programming, Danfoss offers a software program for developing, storing, and transferring programming information. MCT 10 Set-up Software allows the user to connect a PC to the frequency converter and perform live programming rather than using the LCP keypad. Or programming can be done off-line and downloaded to the unit. The entire frequency converter profile can be loaded onto the PC for back-up storage or analysis. A USB connector and RS485 terminal are available for connecting to the frequency converter.

MCT 10 Set-up Software is available for free download at www.VLT-software.com. A CD is also available by requesting

part number 130B1000. A user's manual provides detailed operation instructions. See also *chapter 2.8.2 PC Software*.

Programming control terminals

- Each control terminal has specified functions it is capable of performing.
- Parameters associated with the terminal enable the function selections.
- For proper frequency converter functioning using control terminals, the terminals must be:
 - Wired properly.
 - Programmed for the intended function.

2.8.1 Local Control Panel

The local control panel (LCP) is a graphic display on the front of the unit, which provides the user interface through push-button controls and shows status messages, warnings and alarms, programming parameters, and more. A numeric display is also available with limited display options. *Illustration 2.21* shows the LCP.

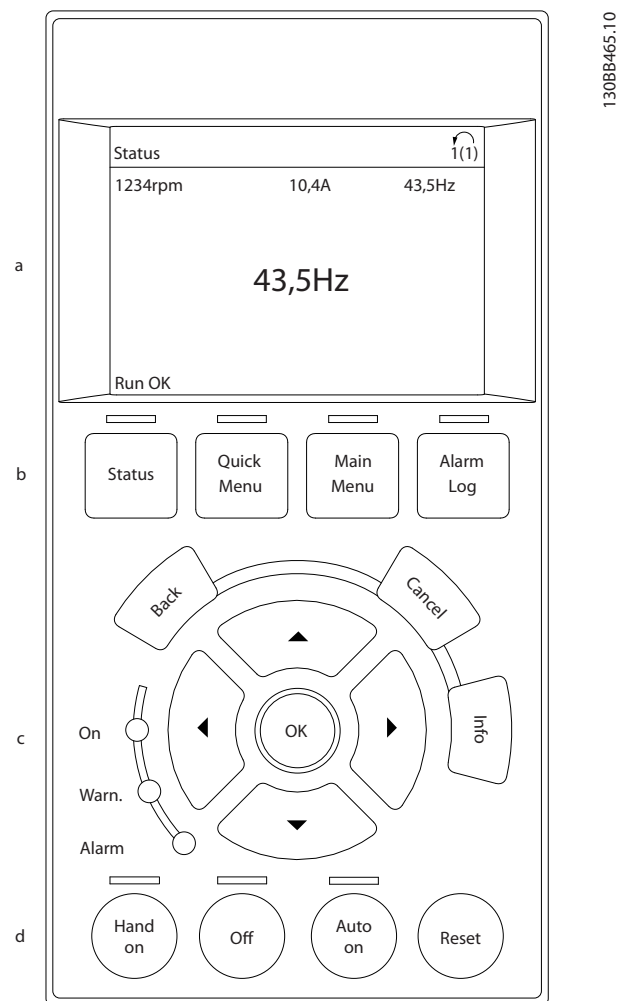

Illustration 2.21 Local Control Panel

2.8.2 PC Software

The PC is connected via a standard (host/device) USB cable, or via the RS485 interface.

USB is a serial bus utilising 4 screened wires with ground pin 4 connected to the screen in the PC USB port. By connecting the PC to a frequency converter through the USB cable, there is a potential risk of damaging the PC USB host controller. All standard PCs are manufactured without galvanic isolation in the USB port.

Any ground potential difference caused by not following the recommendations described in the *operating instructions*, can damage the USB host controller through the screen of the USB cable.

When connecting the PC to a frequency converter through a USB cable, use a USB isolator with galvanic isolation to protect the PC USB host controller from ground potential differences.

Do not use a PC power cable with a ground plug when the PC is connected to the frequency converter through a USB cable. It reduces the ground potential difference, but does not eliminate all potential differences due to the ground and screen connected in the PC USB port.

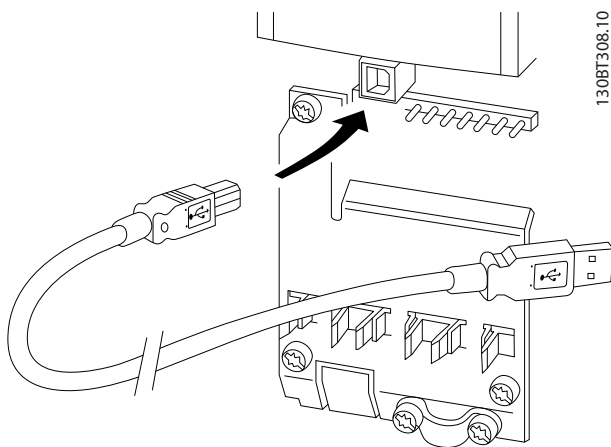

Illustration 2.22 USB Connection

2.8.2.1 MCT 10 Set-up Software

The MCT 10 Set-up Software is designed for commissioning and servicing the frequency converter including guided programming of pack controller, real time clock, smart logic controller, and preventive maintenance. This software provides easy control of details as well as a general overview of systems, large, or small. The tool handles all frequency converter series, VLT® Advanced Active Filters AAF 006 and VLT® Soft Starter-related data.

Example 1: Data storage in PC via MCT 10 Set-up Software

1. Connect a PC to the unit via USB or via the RS485 interface.
2. Open MCT 10 Set-up Software.
3. Select the USB port or the RS485 interface.
4. Select *copy*.
5. Select the *project* section.
6. Select *paste*.
7. Select *save as*.

All parameters are now stored.

Example 2: Data transfer from PC to frequency converter via MCT 10 Set-up Software

1. Connect a PC to the unit via USB port or via the RS485 interface.
2. Open MCT 10 Set-up Software.
3. Select *Open* – stored files are shown.
4. Open the appropriate file.
5. Select *Write to drive*.

All parameters are now transferred to the frequency converter.

A separate manual for MCT 10 Set-up Software is available. Download the software and the manual from www.danfoss.com/BusinessAreas/DrivesSolutions/Software-download/.

2.8.2.2 VLT® Harmonics Calculation Software MCT 31

The MCT 31 Harmonic Calculation PC tool enables easy estimation of the harmonic distortion in a given application. Both the harmonic distortion of Danfoss frequency converters as well as non-Danfoss frequency converters with additional harmonic reduction devices, such as Danfoss VLT® Advanced Harmonic Filters AHF 005/AHF 010 filters and 12–18 pulse rectifiers, can be calculated.

MCT 31 can also be downloaded from www.danfoss.com/BusinessAreas/DrivesSolutions/Software-download/.

2.8.2.3 Harmonic Calculation Software (HCS)

HCS is an advanced version of the harmonic calculation tool. The calculated results are compared to relevant norms and can be printed afterwards.

For more information, see www.danfoss-hcs.com/Default.asp?LEVEL=START

2.9 Maintenance

Danfoss frequency converter models up to 90 kW are maintenance-free. High-power frequency converters (rated at 110 kW or higher) have built-in filter mats, which require periodic cleaning by the operator, depending on the exposure to dust and contaminants. Maintenance intervals for the cooling fans (approximately 3 years) and capacitors (approximately 5 years) are recommended in most environments.

2.9.1 Storage

Like all electronic equipment, frequency converters must be stored in a dry location. Periodic forming (capacitor charging) is not necessary during storage.

It is recommended to keep the equipment sealed in its packaging until installation.

3 System Integration

This chapter describes the considerations necessary to integrate the frequency converter into a system design. The chapter is divided into these sections:

- *Chapter 3.1 Ambient Operating Conditions*
Ambient operating conditions for the frequency converter including:
 - Environment.
 - Enclosures.
 - Temperature.
 - Derating.
 - Other considerations.
- *Chapter 3.2 EMC, Harmonics, and Ground Leakage Protection*
Input (regeneration) from the frequency converter to the power grid including:
 - Power.
 - Harmonics.
 - Monitoring.
 - Other considerations.
- *Chapter 3.4 Mains Integration*
Input into the frequency converter from the mains side including:
 - Power.
 - Harmonics.
 - Monitoring.
 - Cabling.
 - Fusing.
 - Other considerations.
- *Chapter 3.5 Motor Integration*
Output from the frequency converter to the motor including:
 - Motor types.
 - Load.
 - Monitoring.
 - Cabling.
 - Other considerations.
- *Chapter 3.6 Additional Inputs and Outputs, chapter 3.7 Mechanical Planning*
Integration of the frequency converter input and output for optimal system design including:
 - Frequency converter/motor matching.
 - System characteristics.
 - Other considerations.

A comprehensive system design anticipates potential problem areas while implementing the most effective combination of frequency converter features. The information that follows provides guidelines for planning and specifying a motor-control system incorporating frequency converters.

Operational features provide a range of design concepts, from simple motor speed control to a fully integrated automation system with for example:

- Handling of feedback.
- Operational status reporting.
- Automated fault responses.
- Remote programming.

A complete design concept includes detailed specification of needs and use.

- Frequency converter types
- Motors
- Mains requirements
- Control structure and programming
- Serial communication
- Equipment size, shape, weight
- Power and control cabling requirements; type and length
- Fuses
- Auxiliary equipment
- Transportation and storage

See *chapter 3.10 System Design Checklist* for a practical guide for selection and design.

Understanding features and strategy options can optimise a system design and possibly avoid introducing redundant components or functionality.

3.1 Ambient Operating Conditions

3.1.1 Humidity

Although the frequency converter can operate properly at high humidity (up to 95% relative humidity), avoid condensation. There is a specific risk of condensation when the frequency converter is colder than moist ambient air. Moisture in the air can also condense on the electronic components and cause short circuits. Condensation occurs in units without power. Install a cabinet heater when

condensation is possible due to ambient conditions. Avoid installation in areas subject to frost.

Alternatively, operating the frequency converter in stand-by mode (with the unit connected to the mains) reduces the risk of condensation. Ensure that the power dissipation is sufficient to keep the frequency converter circuitry free of moisture.

3.1.2 Temperature

Minimum and maximum ambient temperature limits are specified for all frequency converters. Avoiding extreme ambient temperatures prolongs the life of the equipment and maximises overall system reliability. Follow the recommendations listed for maximum performance and equipment longevity.

- Although the frequency converter can operate at temperatures down to -10 °C, proper operation at rated load is only guaranteed at 0 °C or higher.
- Do not exceed the maximum temperature limit.
- The lifetime of electronic components decreases by 50% for every 10 °C when operated above the design temperature.
- Even devices with IP54, IP55, or IP66 protection ratings must adhere to the specified ambient temperature ranges.
- Extra air conditioning of the enclosure or installation site may be required.

3.1.3 Cooling

Frequency converters dissipate power in the form of heat. The following recommendations are necessary for effective cooling of the units.

- Maximum air temperature to enter enclosure must never exceed 40 °C (104 °F).
- Day/night average temperature must not exceed 35 °C (95 °F).
- Mount the unit to allow free cooling airflow through the cooling fins. See *chapter 3.7.1 Clearance* for correct mounting clearances.
- Provide minimum front and rear clearance requirements for cooling airflow. See the *operating instructions* for proper installation requirements.

3.1.3.1 Fans

The frequency converter has built-in fans to ensure optimum cooling. The main fan forces the air flow along the cooling fins on the heat sink, ensuring cooling of the internal air. Some power sizes have a small secondary fan close to the control card, ensuring that the internal air is circulated to avoid hot spots.

The internal temperature in the frequency converter controls the main fan. The speed gradually increases along with temperature, reducing noise and energy consumption when the need is low, and ensuring maximum cooling when the need is there. The fan control can be adapted via *parameter 14-52 Fan Control* to accommodate any application, also to protect against negative effects of cooling in cold climates. In case of overtemperature inside the frequency converter, it derates the switching frequency and pattern. See *chapter 5.1 Derating* for more info.

3.1.3.2 Calculation of Airflow Required for Cooling the Frequency Converter

The airflow required to cool a frequency converter, or multiple frequency converters in 1 enclosure, can be calculated as follows:

1. Determine the power loss at maximum output for all frequency converters from data tables in *chapter 7 Specifications*.
2. Add power loss values of all frequency converters that can operate at same time. The calculated sum is the heat Q to be transferred. Multiply the result with the factor f, read from *Table 3.1*. For example, f = 3.1 m³ x K/Wh at sea level.
3. Determine the highest temperature of the air entering the enclosure. Subtract this temperature from the required temperature inside the enclosure, for example 45 °C (113 °F).
4. Divide the total from step 2 by the total from step 3.

The calculation is expressed by the formula:

$$V = \frac{f \times Q}{T_i - T_A}$$

where

V = airflow in m³/h

f = factor in m³ x K/Wh

Q = heat to be transferred in W

T_i = temperature inside the enclosure in °C

T_A = ambient temperature in °C

f = cp x ρ (specific heat of air x density of air)

NOTICE

Specific heat of air (c_p) and density of air (ρ) are not constants, but depend on temperature, humidity, and atmospheric pressure. Therefore, they depend on the altitude above sea level.

Table 3.1 shows typical values of the factor f , calculated for different altitudes.

Altitude	Specific heat of air c_p	Density of air ρ	Factor f
[m]	[kJ/kgK]	[kg/m ³]	[m ³ ·K/Wh]
0	0.9480	1.225	3.1
500	0.9348	1.167	3.3
1000	0.9250	1.112	3.5
1500	0.8954	1.058	3.8
2000	0.8728	1.006	4.1
2500	0.8551	0.9568	4.4
3000	0.8302	0.9091	4.8
3500	0.8065	0.8633	5.2

Table 3.1 Factor f , Calculated for Different Altitudes

Example

What is the airflow required to cool 2 frequency converters (heat losses 295 W and 1430 W) running simultaneously, mounted in an enclosure with an ambient temperature peak of 37 °C?

- The sum of the heat losses of both frequency converters is 1725 W.
- Multiplying 1725 W by 3.3 m³ x K/Wh gives 5693 m x K/h.
- Subtracting 37 °C from 45 °C gives 8 °C (=8 K).
- Dividing 5693 m x K/h by 8 K gives: 711.6 m³/h.

If the airflow is required in CFM, use the conversion 1 m³/h = 0.589 CFM.

For the example above, 711.6 m³/h = 418.85 CFM.

3.1.4 Motor-generated Overvoltage

The DC voltage in the DC link (DC bus) increases when the motor acts as a generator. This situation can occur in 2 ways:

- The load drives the motor when the frequency converter is operated at a constant output frequency. This is referred to as an overhauling load.
- During deceleration, if the inertia of the load is high and the deceleration time of the frequency converter is set to a short value.

The frequency converter cannot regenerate energy back to the input. Therefore, it limits the energy accepted from the motor when set to enable autoramping. If the overvoltage

occurs during deceleration, the frequency converter attempts to do this by automatically lengthening the ramp-down time. If this is unsuccessful, or if the load drives the motor when operating at a constant frequency, the frequency converter shuts down and shows a fault when reaching a critical DC bus voltage level.

3.1.5 Acoustic Noise

Acoustic noise from the frequency converter comes from 3 sources:

- DC-link (intermediate circuit) coils
- RFI filter choke
- Internal fans

See Table 7.40 for acoustic noise ratings.

3.1.6 Vibration and Shock

The frequency converter is tested according to a procedure based on the IEC 68-2-6/34/35 and 36. These tests subject the unit to 0.7 g forces, over the range of 18–1000 Hz randomly, in 3 directions, for 2 hours. All Danfoss frequency converters comply with requirements that correspond to these conditions when the unit is wall- or floor-mounted, as well as when mounted within panels, or bolted to walls or floors.

3.1.7 Aggressive Atmospheres**3.1.7.1 Gases**

Aggressive gases, such as hydrogen sulphide, chlorine, or ammonia can damage frequency converter electrical and mechanical components. Contamination of the cooling air can also cause the gradual decomposition of PCB tracks and door seals. Aggressive contaminants are often present in sewage treatment plants or swimming pools. A clear sign of an aggressive atmosphere is corroded copper.

In aggressive atmospheres, restricted IP enclosures are recommended along with conformal-coated circuit boards. See Table 3.2 for conformal-coating values.

NOTICE

The frequency converter comes standard with class 3C2 coating of circuit boards. On request, class 3C3 coating is available.

Gas type	Unit	Class				
		3C1	3C2		3C3	
			Average value	Maximum value ¹⁾	Average value	Maximum value ¹⁾
Sea salt	n/a	None	Salt mist		Salt mist	
Sulphur oxides	mg/m ³	0.1	0.3	1.0	5.0	10
Hydrogen sulphide	mg/m ³	0.01	0.1	0.5	3.0	10
Chlorine	mg/m ³	0.01	0.1	0.03	0.3	1.0
Hydrogen chloride	mg/m ³	0.01	0.1	0.5	1.0	5.0
Hydrogen fluoride	mg/m ³	0.003	0.01	0.03	0.1	3.0
Ammonia	mg/m ³	0.3	1.0	3.0	10	35
Ozone	mg/m ³	0.01	0.05	0.1	0.1	0.3
Nitrogen	mg/m ³	0.1	0.5	1.0	3.0	9.0

Table 3.2 Conformal-coating Class Ratings

1) Maximum values are transient peak values not to exceed 30 minutes per day.

3.1.7.2 Dust Exposure

Installation of frequency converters in environments with high dust exposure is often unavoidable. Dust affects wall- or frame-mounted units with IP55 or IP66 protection ratings, and also cabinet-mounted devices with IP21 or IP20 protection ratings. Consider the 3 aspects described in this section when frequency converters are installed in such environments.

Reduced cooling

Dust forms deposits on the surface of the device and inside on circuit boards and the electronic components. These deposits act as insulation layers and hamper heat transfer to the ambient air, reducing the cooling capacity. The components become warmer, which causes accelerated aging of the electronic components, and the service life of the unit decreases. Dust deposits on the heat sink in the back of the unit also decrease the service life of the unit.

Cooling fans

The airflow for cooling the unit is produced by cooling fans, mostly located on the back of the device. The fan rotors have small bearings into which dust can penetrate and act as an abrasive. Dust in the bearings leads to bearing damage and fan failure.

Filters

High-power frequency converters are equipped with cooling fans that expel hot air from the interior of the device. Above a certain size, these fans are fitted with filter mats. These filters can become quickly clogged when used in dusty environments. Preventive measures are necessary under these conditions.

Periodic maintenance

Under the conditions described above, it is recommended to clean the frequency converter during periodic maintenance. Remove dust from the heat sink and fans, and clean the filter mats.

3.1.8 IP Rating Definitions

		Against penetration by solid foreign objects	Against access to hazardous parts by
First digit	0	(not protected)	(not protected)
	1	≥50 mm diameter	Back of hand
	2	12.5 mm diameter	Finger
	3	2.5 mm diameter	Tool
	4	≥1.0 mm diameter	Wire
	5	Dust protected	Wire
	6	Dust-tight	Wire
		Against water penetration with harmful effect	
Second digit	0	(not protected)	–
	1	Drops falling vertically	–
	2	Drops at 15° angle	–
	3	Spraying water	–
	4	Splashing water	–
	5	Water jets	–
	6	Powerful water jets	–
	7	Temporary immersion	–
8	Long-term immersion	–	
		More information specifically for	
First letter	A		Back of hand
	B		Finger
	C		Tool
	D		Wire
		More information specifically for	
Extra letter	H	High-voltage device	–
	M	Device moving during water test	–
	S	Device stationary during water test	–
	W	Weather conditions	–

Table 3.3 IEC 60529 Definitions for IP Ratings

3.1.8.1 Cabinet Options and Ratings

Danfoss frequency converters are available with 3 different protection ratings:

- IP00 or IP20 for cabinet installation.
- IP54 or IP55 for local mounting.
- IP66 for critical ambient conditions, such as extremely high (air) humidity or high concentrations of dust or aggressive gases.

3.1.9 Radio Frequency Interference

The main objective in practice is to obtain systems that operate constantly without radio frequency interference between components. To achieve a high level of immunity, use frequency converters with high-quality RFI filters.

Use Category C1 filters specified in the EN 61800-3 which conform to the Class B limits of the general standard EN 55011.

Place warning notices on the frequency converter if RFI filters do not correspond to Category C1 (Category C2 or lower). The responsibility for proper labelling rests with the operator.

In practice, there are 2 approaches to RFI filters:

- Built in to the equipment
 - Built-in filters take up space in the cabinet but eliminate extra costs for fitting, wiring, and material. However, the most important advantage is the perfect EMC conformance and cabling of integrated filters.
- External options
 - Optional external RFI filters that are installed on the input of the frequency converter cause a voltage drop. In practice, this means that the full mains voltage is not present at the frequency converter input and a higher-rated frequency converter may be necessary. The maximum length of the motor cable for compliance with EMC limits ranges from 1–50 m. Costs are incurred for material, cabling, and assembly. EMC conformance is not tested.

NOTICE

To ensure interference-free operation of the frequency converter/motor system, always use a category C1 RFI filter.

NOTICE

VLT® Refrigeration Drive FC 103 units are supplied as standard with built-in RFI filters conforming to category C1 (EN 61800-3) for use with 400 V mains systems and power ratings up to 90 kW or category C2 for power ratings of 110–630 kW. FC 103 units conform to C1 with screened motor cables up to 50 m or C2 with screened motor cables up to 150 m. Refer to *Table 3.4* for details.

3.1.10 PELV and Galvanic Isolation Compliance

Ensure the protection against electric shock, when the electrical supply is of the protective extra-low voltage (PELV) type, and the installation complies with local and national PELV regulations.

To maintain PELV at the control terminals, all connections must be PELV, such as thermistors being reinforced/double insulated. All Danfoss frequency converter control and relay terminals comply with PELV (excluding grounded Delta leg above 400 V).

Galvanic (ensured) isolation is obtained by fulfilling requirements for higher isolation and by providing the relevant creepage/clearance distances. These requirements are described in the EN 61800-5-1 standard.

Electrical isolation is provided as shown in *Illustration 3.1*. The components described comply with both PELV and the galvanic isolation requirements.

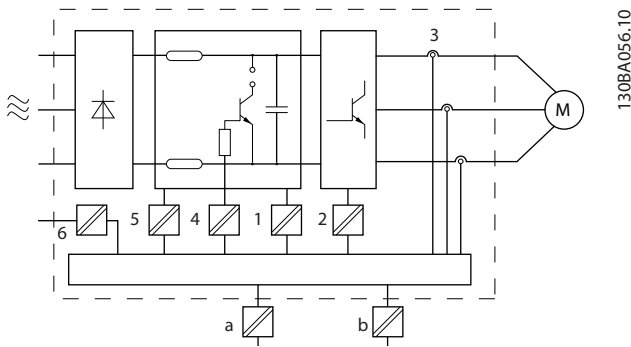

130BA056.10

1	Power supply (SMPS) including signal isolation of V DC, indicating the intermediate current voltage
2	Gate drive for the IGBTs
3	Current transducers
4	Opto-coupler, brake module
5	Internal inrush, RFI, and temperature measurement circuits
6	Custom relays
a	Galvanic isolation for the 24 V back-up option
b	Galvanic isolation for the RS485 standard bus interface

Illustration 3.1 Galvanic Isolation

Installation at high altitude



OVERVOLTAGE Installations exceeding high altitude limits may not comply with PELV requirements. The isolation between components and critical parts could be insufficient. There is a risk for overvoltage. To reduce the risk for overvoltage, use external protective devices or galvanic isolation.

For installations at high altitude, contact Danfoss regarding PELV compliance.

- 380–500 V (enclosures A, B, and C): Above 2000 m (6500 ft)
- 380–500 V (enclosures D, E, and F): Above 3000 m (9800 ft)
- 525–690 V: Above 2000 m (6500 ft)

3.2 EMC, Harmonics, and Ground Leakage Protection

3.2.1 General Aspects of EMC Emissions

Frequency converters (and other electrical devices) generate electronic or magnetic fields that may interfere with their environment. The electromagnetic compatibility (EMC) of these effects depends on the power and the harmonic characteristics of the devices.

Uncontrolled interaction between electrical devices in a system can degrade compatibility and impair reliable operation. Interference may take the form of:

- Mains harmonics distortion.
- Electrostatic discharges.
- Rapid voltage fluctuations.
- High-frequency interference.

Electrical devices generate interference and are affected by interference from other generated sources.

Electrical interference usually occurs at frequencies in the range 150 kHz to 30 MHz. Airborne interference from the frequency converter system in the range 30 MHz to 1 GHz is generated from the inverter, motor cable, and the motor. Capacitive currents in the motor cable coupled with a high dU/dt from the motor voltage generate leakage currents, as shown in *Illustration 3.2*.

The use of a screened motor cable increases the leakage current (see *Illustration 3.2*) because screened cables have higher capacitance to ground than unscreened cables. If the leakage current is not filtered, it causes greater interference on the mains in the radio frequency range below approximately 5 MHz. Since the leakage current (I_1) is carried back to the unit through the screen (I_3), there is only a small electro-magnetic field (I_4) from the screened motor cable, see *Illustration 3.2*.

The screen reduces the radiated interference, but increases the low-frequency interference on the mains. Connect the motor cable screen to the frequency converter enclosure as well as on the motor enclosure. The connection is best done by using integrated screen clamps to avoid twisted screen ends (pigtailed). Pigtailed increase the screen impedance at higher frequencies, which reduces the screen effect and increases the leakage current (I_4).

If a screened cable is used for relay, control cable, signal interface, and brake, mount the screen on the enclosure at both ends. In some situations, however, it is necessary to break the screen to avoid current loops.

If placing the screen on a mounting plate for the frequency converter, use a mounting plate of metal to convey the screen currents back to the unit. Moreover, ensure good electrical contact from the mounting plate through the mounting screws to the frequency converter enclosure.

When using unscreened cables, some emission requirements are not complied with, although most immunity requirements are observed.

To reduce the interference level from the entire system (unit+installation), make motor and brake cables as short

as possible. Avoid placing cables with a sensitive signal level alongside motor and brake cables. Especially the

control electronics generate radio interference higher than 50 MHz (airborne).

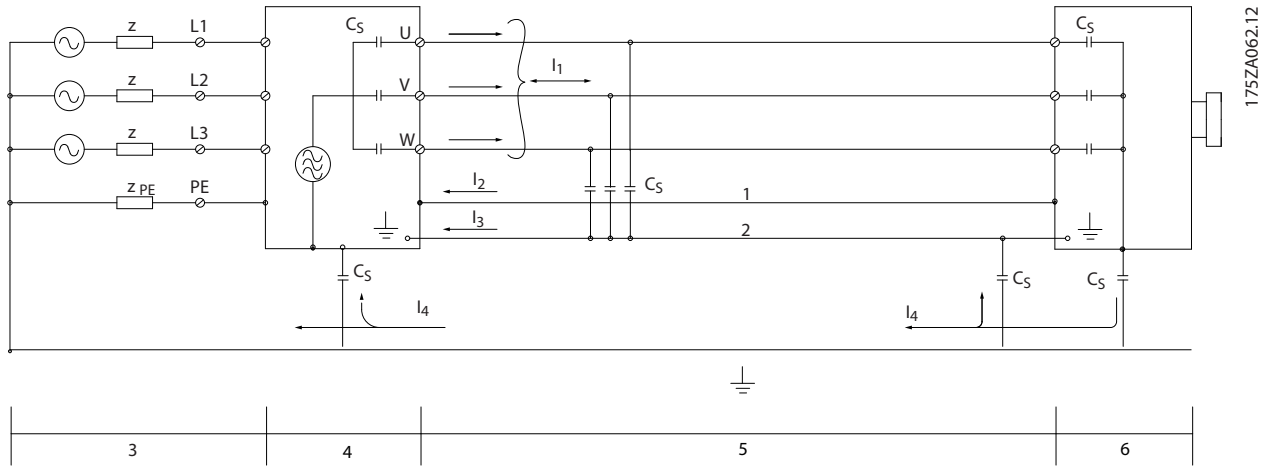

1	Ground wire	3	AC mains supply	5	Screened motor cable
2	Screen	4	Frequency converter	6	Motor

Illustration 3.2 Generation of Leakage Currents

3.2.2 EMC Test Results (Emission)

The following test results have been obtained using a system with a frequency converter (with options if relevant), a screened control cable, a control box with potentiometer, as well as a motor and motor screened cable.

3

RFI filter type		Conducted emission			Radiated emission		
		Cable length [m]			Cable length [m]		
Standards and requirements	EN 55011	Class B Housing, trades, and light industries	Class A Group 1 Industrial environment	Class A Group 2 Industrial environment	Class B Housing, trades, and light industries	Class A Group 1 Industrial environment	Class A Group 2 Industrial environment
	EN/IEC 61800-3	Category C1 First environment Home and office	Category C2 First environment Home and office	Category C3 Second environment Industrial	Category C1 First environment Home and office	Category C2 First environment Home and office	Category C3 Second environment Industrial
H1							
1.1–22 kW 220–240 V		50	150	150	No	Yes	N/A
1.1–45 kW 200–240 V		50	150	150	No	Yes	Yes
1.1–90 kW 380–480 V		50	150	150	No	Yes	Yes
H2/H5							
1.1–22 kW 220–240 V		No	No	25	No	No	N/A
1.1–3.7 kW 200–240 V		No	No	5	No	No	No
5.5–45 kW 200–240 V		No	No	25	No	No	No
1.1–7.5 kW 380–480 V		No	No	5	No	No	No
11–90 kW 380–480 V		No	No	25	No	No	No
HX							
1.1–90 kW 525–600 V		No	No	No	No	No	No

Table 3.4 EMC Test Results (Emission)

HX, H1 or H2 is defined in the type code pos. 16–17 for EMC filters.

HX – No EMC filters built in the frequency converter (600 V units only).

H1 – Integrated EMC filter. Fulfil Class A1/B.

H2 – No additional EMC filter. Fulfil Class A2.

H5 – Marine versions. Fulfil same emissions levels as H2 versions.

3.2.3 Emission Requirements

The EMC product standard for frequency converters defines 4 categories (C1, C2, C3, and C4) with specified requirements for emission and immunity. *Table 3.5* states the definition of the 4 categories and the equivalent classification from EN 55011.

Category	Definition	Equivalent emission class in EN 55011
C1	Frequency converters installed in the first environment (home and office) with a supply voltage less than 1000 V.	Class B
C2	Frequency converters installed in the first environment (home and office) with a supply voltage less than 1000 V, which are not plug-in and not movable, and must be installed and commissioned by a professional.	Class A Group 1
C3	Frequency converters installed in the second environment (industrial) with a supply voltage lower than 1000 V.	Class A Group 2
C4	Frequency converters installed in the second environment with a supply voltage equal to or above 1000 V or rated current equal to or above 400 A or intended for use in complex systems.	No limit line. Make an EMC plan.

Table 3.5 Correlation between IEC 61800-3 and EN 55011

When the generic (conducted) emission standards are used, the frequency converters are required to comply with the limits in *Table 3.6*.

Environment	Generic emission standard	Equivalent emission class in EN 55011
First environment (home and office)	EN/IEC 61000-6-3 Emission standard for residential, commercial, and light industrial environments.	Class B
Second environment (industrial environment)	EN/IEC 61000-6-4 Emission standard for industrial environments.	Class A Group 1

Table 3.6 Correlation between Generic Emission Standards and EN 55011

3.2.4 Immunity Requirements

The immunity requirements for frequency converters depend on the environment where they are installed. The requirements for the industrial environment are higher than the requirements for the home and office environment. All Danfoss frequency converters comply with the requirements for the industrial environment. Therefore, the frequency converters also comply with the lower requirements for home and office environment with a large safety margin.

To document immunity against electrical interference, the following immunity tests have been made in accordance with following basic standards:

- **EN 61000-4-2 (IEC 61000-4-2):** Electrostatic discharges (ESD): Simulation of electrostatic discharges from human beings.
- **EN 61000-4-3 (IEC 61000-4-3):** Incoming electromagnetic field radiation, amplitude modulated simulation of the effects of radar and radio communication equipment as well as mobile communications equipment.
- **EN 61000-4-4 (IEC 61000-4-4):** Burst transients: Simulation of interference brought about by switching a contactor, relay, or similar devices.
- **EN 61000-4-5 (IEC 61000-4-5):** Surge transients: Simulation of transients brought about for example by lightning that strikes near installations.
- **EN 61000-4-6 (IEC 61000-4-6):** RF common mode: Simulation of the effect from radio-transmission equipment joined by connection cables.

See *Table 3.7*.

Basic standard	Burst ²⁾ IEC 61000-4-42)	Surge ²⁾ IEC 61000-4-5	ESD ²⁾ IEC 61000-4-2	Radiated electromagnetic field IEC 61000-4-3	RF common mode voltage IEC 61000-4-6
Acceptance criterion	B	B	B	A	A
Voltage range: 200–240 V, 380–500 V, 525–600 V, 525–690 V					
Line	4 kV CM	2 kV/2 Ω DM 4 kV/12 Ω CM	—	—	10 V _{RMS}
Motor	4 kV CM	4 kV/2 Ω ¹⁾	—	—	10 V _{RMS}
Control wires	2 kV CM	2 kV/2 Ω ¹⁾	—	—	10 V _{RMS}
Standard bus	2 kV CM	2 kV/2 Ω ¹⁾	—	—	10 V _{RMS}
Relay wires	2 kV CM	2 kV/2 Ω ¹⁾	—	—	10 V _{RMS}
Application and Fieldbus options	2 kV CM	2 kV/2 Ω ¹⁾	—	—	10 V _{RMS}
LCP cable	2 kV CM	2 kV/2 Ω ¹⁾	—	—	10 V _{RMS}
External 24 V DC	2 V CM	0.5 kV/2 Ω DM 1 kV/12 Ω CM	—	—	10 V _{RMS}
Enclosure	—	—	8 kV AD 6 kV CD	10 V/m	—

Table 3.7 EMC Immunity Form

1) Injection on cable screen.

2) Values typically obtained by testing.

3.2.5 Motor Insulation

Modern motors for use with frequency converters have a high degree of insulation to account for new generation high-efficiency IGBTs with high dU/dt. For retrofit in old motors, confirm the motor insulation or mitigate with dU/dt filter or, if necessary, a sine-wave filter.

For motor cable lengths \leq the maximum cable length listed in *chapter 7 Specifications*, the motor insulation ratings listed in *Table 3.8* are recommended. If a motor has lower insulation rating, use a dU/dt or sine-wave filter.

Nominal mains voltage [V]	Motor insulation [V]
$U_N \leq 420$	Standard $U_{LL} = 1300$
$420 \text{ V} < U_N \leq 500$	Reinforced $U_{LL} = 1600$
$500 \text{ V} < U_N \leq 600$	Reinforced $U_{LL} = 1800$
$600 \text{ V} < U_N \leq 690$	Reinforced $U_{LL} = 2000$

Table 3.8 Motor Insulation

3.2.6 Motor Bearing Currents

To minimise bearing and shaft currents, ground the following to the driven machine:

- Frequency converter
- Motor
- Driven machine

Standard mitigation strategies

1. Use an insulated bearing.
2. Apply rigorous installation procedures:
 - 2a Ensure that the motor and motor load are aligned.
 - 2b Strictly follow the EMC Installation guideline.
 - 2c Reinforce the PE so the high frequency impedance is lower in the PE than the input power leads.
 - 2d Provide a good high-frequency connection between the motor and the frequency converter, for instance, by screened cable which has a 360° connection in the motor and the frequency converter.
 - 2e Make sure that the impedance from frequency converter to building ground is lower than the grounding impedance

- of the machine. This can be difficult for pumps.
- 2f Make a direct ground connection between the motor and motor load (for example pump).
 3. Lower the IGBT switching frequency.
 4. Modify the inverter waveform, 60° AVM vs. SFAVM.
 5. Install a shaft grounding system or use an isolating coupling.
 6. Apply conductive lubrication.
 7. Use minimum speed settings if possible.
 8. Try to ensure that the mains voltage is balanced to ground. This can be difficult for IT, TT, TN-CS, or Grounded leg systems.
 9. Use a dU/dt or sine-wave filter.

3.2.7 Harmonics

Electrical devices with diode rectifiers, such as

- Fluorescent lights
- Computers
- Copiers
- Fax machines
- Various laboratory equipment, and
- Telecommunications systems

can add harmonic distortion to a mains supply. Frequency converters use a diode bridge input, which can also contribute to harmonic distortion.

The frequency converter does not draw current uniformly from the power line. This non-sinusoidal current has components that are multiples of the fundamental current frequency. These components are referred to as harmonics. It is important to control the total harmonic distortion on the mains supply. Although the harmonic currents do not directly affect electrical energy consumption, they generate heat in wiring and transformers. This heat generation can affect other devices on the same power line.

3.2.7.1 Harmonic Analysis

Various characteristics of a building's electrical system determine the exact harmonic contribution of the frequency converter to the THD of a facility and its ability to meet IEEE standards. Generalisations about the harmonic contribution of frequency converters on a specific facility is difficult. When necessary, perform an analysis of the system harmonics to determine equipment effects.

A frequency converter takes up a non-sinusoidal current from mains, which increases the input current I_{RMS} . A non-sinusoidal current is transformed with a Fourier series analysis and split up into sine-wave currents with different frequencies, that is, different harmonic currents I_n with 50 Hz or 60 Hz as the fundamental frequency.

The harmonics do not affect the power consumption directly, but increase the heat losses in the installation (transformer, inductors, cables). So, in power plants with a high percentage of rectifier load, keep harmonic currents at a low level to avoid overload of the transformer, inductors, and cables.

Abbreviation	Description
f_1	Fundamental frequency
I_1	Fundamental current
U_1	Fundamental voltage
I_n	Harmonic currents
U_n	Harmonic voltage
n	Harmonic order

Table 3.9 Harmonics-related Abbreviations

	Fundamental current (I_1)	Harmonic current (I_n)		
		I_5	I_7	I_{11}
Current	I_1	I_5	I_7	I_{11}
Frequency [Hz]	50	250	350	550

Table 3.10 Transformed Non-sinusoidal Current

Current	Harmonic current				
	I_{RMS}	I_1	I_5	I_7	I_{11-49}
Input current	1.0	0.9	0.4	0.2	< 0.1

Table 3.11 Harmonic Currents Compared to the RMS Input Current

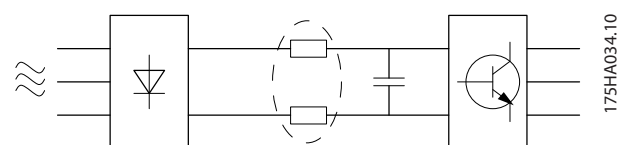

Illustration 3.3 DC-link Coils

NOTICE

Some of the harmonic currents can disturb communication equipment connected to the same transformer or cause resonance with power factor correction capacitors.

To ensure low harmonic currents, the frequency converter is equipped with passive filters. DC-coils reduce the total harmonic distortion (THD) to 40%.

The voltage distortion on the mains supply voltage depends on the size of the harmonic currents multiplied by the mains impedance for the frequency in question. The

total voltage distortion (THD) is calculated based on the individual voltage harmonics using this formula:

$$THD = \frac{\sqrt{U_5^2 + U_7^2 + \dots + U_N^2}}{U_1}$$

3.2.7.2 Harmonics Emission Requirements

Equipment connected to the public supply network

Option	Definition
1	IEC/EN 61000-3-2 Class A for 3-phase balanced equipment (for professional equipment only up to 1 kW total power).
2	IEC/EN 61000-3-12 Equipment 16–75 A and professional equipment as from 1 kW up to 16 A phase current.

Table 3.12 Harmonics Emission Standards

3.2.7.3 Harmonics Test Results (Emission)

Power sizes up to PK75 in T2 and T4 comply with IEC/EN 61000-3-2 Class A. Power sizes from P1K1 and up to P18K in T2 and up to P90K in T4 comply with IEC/EN 61000-3-12, Table 4. Power sizes P110–P450 in T4 also comply with IEC/EN 61000-3-12 even though not required because currents are above 75 A.

Table 3.13 describes that the short-circuit power of the supply S_{sc} at the interface point between the user's supply and the public system (R_{sce}) is greater than or equal to:

$$S_{sc} = \sqrt{3} \times R_{sce} \times U_{mains} \times I_{equ} = \sqrt{3} \times 120 \times 400 \times I_{equ}$$

	Individual harmonic current I_n/I_1 (%)			
	I_5	I_7	I_{11}	I_{13}
Actual (typical)	40	20	10	8
Limit for $R_{sce} \geq 120$	40	25	15	10
	Harmonic current distortion factor (%)			
	THD	PWHD		
Actual (typical)	46	45		
Limit for $R_{sce} \geq 120$	48	46		

Table 3.13 Harmonics Test Results (Emission)

It is the responsibility of the installer or user of the equipment to ensure, by consultation with the distribution network operator if necessary, that the equipment is connected only to a supply with a short-circuit power S_{sc} greater than or equal to that specified in the equation. To connect other power sizes to the public supply network, consult the distribution network operator.

Compliance with various system level guidelines: The harmonic current data in Table 3.13 are provided in accordance with IEC/EN61000-3-12 with reference to the power drive systems product standard. They may be used as the basis for calculation of the influence harmonic

currents have on the supply system and for the documentation of compliance with relevant regional guidelines: IEEE 519 -1992; G5/4.

3.2.7.4 Effect of Harmonics in a Power Distribution System

In Illustration 3.4, a transformer is connected on the primary side to a point of common coupling PCC1, on the medium voltage supply. The transformer has an impedance Z_{xfr} and feeds a number of loads. The point of common coupling where all loads are connected together is PCC2. Each load is connected through cables that have an impedance Z_1, Z_2, Z_3 .

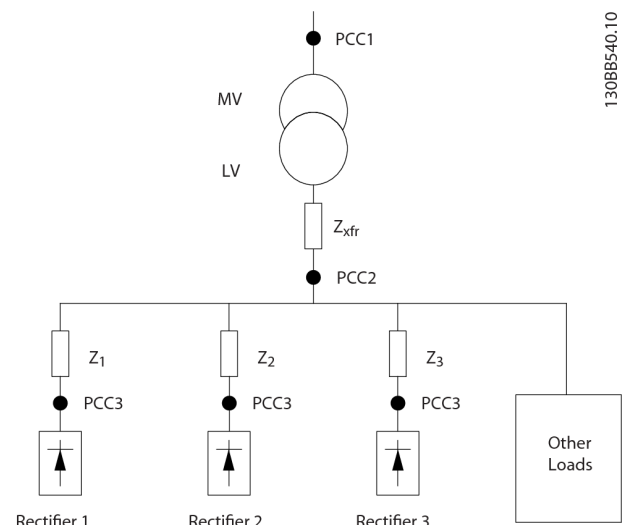

Illustration 3.4 Small Distribution System

Harmonic currents drawn by non-linear loads cause distortion of the voltage because of the voltage drop on the impedances of the distribution system. Higher impedances result in higher levels of voltage distortion.

Current distortion relates to apparatus performance and it relates to the individual load. Voltage distortion relates to system performance. It is not possible to determine the voltage distortion in the PCC knowing only the load's harmonic performance. To predict the distortion in the PCC, the configuration of the distribution system and relevant impedances must be known.

A commonly used term for describing the impedance of a grid is the short-circuit ratio R_{sce} . This ratio is defined as the ratio between the short circuit apparent power of the supply at the PCC (S_{sc}) and the rated apparent power of the load (S_{equ}).

$$R_{sce} = \frac{S_{sc}}{S_{equ}}$$

$$\text{where } S_{sc} = \frac{U^2}{Z_{supply}} \text{ and } S_{equ} = U \times I_{equ}$$

The negative effect of harmonics is 2-fold

- Harmonic currents contribute to system losses (in cabling, transformer).
- Harmonic voltage distortion causes disturbance to other loads and increase losses in other loads.

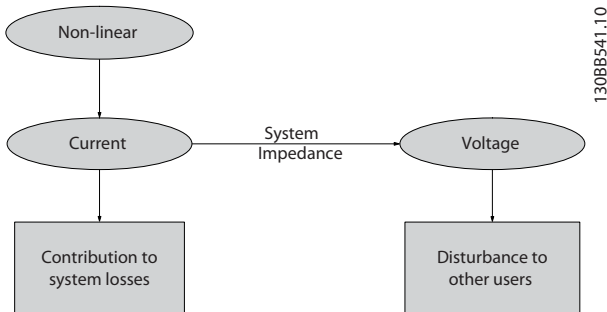

Illustration 3.5 Negative Effects of Harmonics

3.2.7.5 Harmonic Limitation Standards and Requirements

The requirements for harmonic limitation can be:

- Application-specific requirements.
- Standards that must be observed.

The application-specific requirements are related to a specific installation where there are technical reasons for limiting the harmonics.

Example

If 1 of the motors is connected directly online and the other is supplied through a frequency converter, a 250 kVA transformer with 2 110 kW motors connected is sufficient. If both motors are frequency converter supplied, however, the transformer is undersized. Using more means of harmonic reduction within the installation or selecting low harmonic drive variants makes it possible for both motors to run with frequency converters.

There are various harmonic mitigation standards, regulations, and recommendations. Different standards apply in different geographical areas and industries. The following standards are the most common:

- IEC61000-3-2
- IEC61000-3-12
- IEC61000-3-4
- IEEE 519
- G5/4

See the *VLT® Advanced Harmonic Filter AHF 005/AHF 010 Design Guide* for specific details on each standard.

In Europe, the maximum THDv is 8% if the plant is connected via the public grid. If the plant has its own transformer, the limit is 10% THDv. The VLT® Refrigeration Drive FC 103 is designed to withstand 10% THDv.

3.2.7.6 Harmonic Mitigation

In cases where extra harmonic suppression is required, Danfoss offers a wide range of mitigation equipment. These are:

- 12-pulse drives.
- AHF filters.
- Low harmonic drives.
- Active filters.

The choice of the right solution depends on several factors:

- The grid (background distortion, mains unbalance, resonance, and type of supply (transformer/generator).
- Application (load profile, number of loads, and load size).
- Local/national requirements/regulations (IEEE 519, IEC, G5/4, and so on).
- Total cost of ownership (initial cost, efficiency, maintenance, and so on).

Always consider harmonic mitigation if the transformer load has a non-linear contribution of 40% or more.

Danfoss offers tools for calculation of harmonics, see *chapter 2.8.2 PC Software*.

3.2.8 Ground Leakage Current

Follow national and local codes regarding protective earthing of equipment where leakage current exceeds 3.5 mA.

Frequency converter technology implies high frequency switching at high power. This generates a leakage current in the ground connection.

The ground leakage current is made up of several contributions and depends on various system configurations, including:

- RFI filtering.
- Motor cable length.
- Motor cable screening.
- Frequency converter power.

3

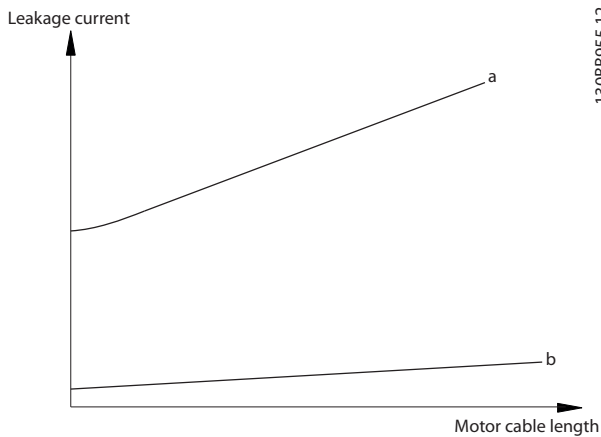

1308B955.12

Illustration 3.6 Motor cable length and power size influence on leakage current. Power size a > power size b

The leakage current also depends on the line distortion.

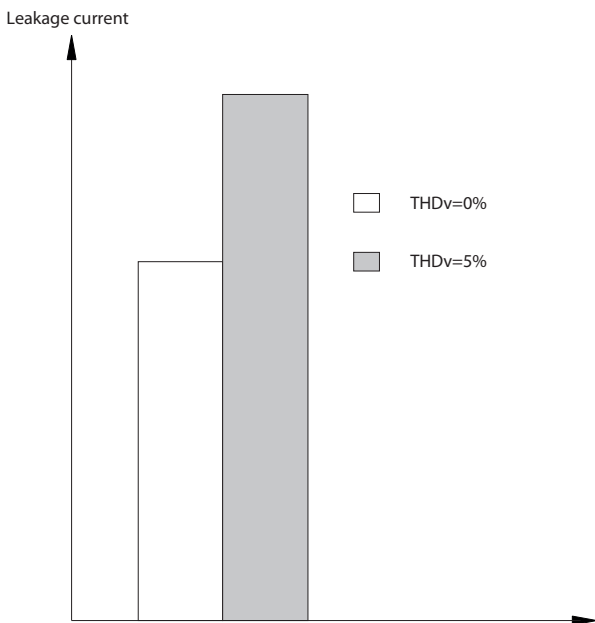

1308B956.12

Illustration 3.7 Line Distortion Influences Leakage Current

If the leakage current exceeds 3.5 mA, compliance with EN/IEC61800-5-1 (power drive system product standard) requires special care. Reinforce grounding with the following protective ground connection requirements:

- Ground wire (terminal 95) of at least 10 mm² cross-section.
- 2 separate ground wires both complying with the dimensioning rules.

See EN/IEC61800-5-1 and EN 50178 for further information.

Using RCDs

Where residual current devices (RCDs), also known as earth leakage circuit breakers (ELCBs), are used, comply with the following:

- Use RCDs of type B only as they can detect AC and DC currents.
- Use RCDs with a delay to prevent faults due to transient ground currents.
- Dimension RCDs according to the system configuration and environmental considerations.

The leakage current includes several frequencies originating from both the mains frequency and the switching frequency. Whether the switching frequency is detected depends on the type of RCD used.

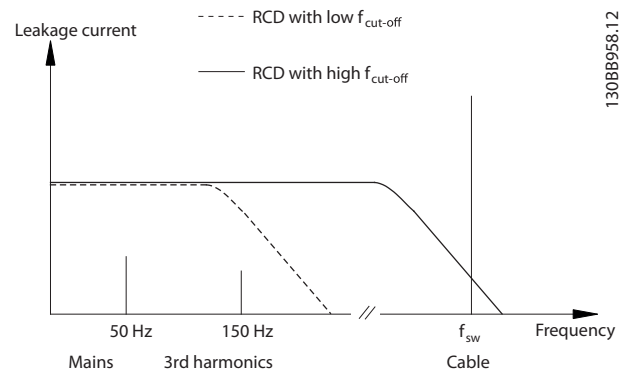

1308B958.12

Illustration 3.8 Main Contributions to Leakage Current

The amount of leakage current detected by the RCD depends on the cut-off frequency of the RCD.

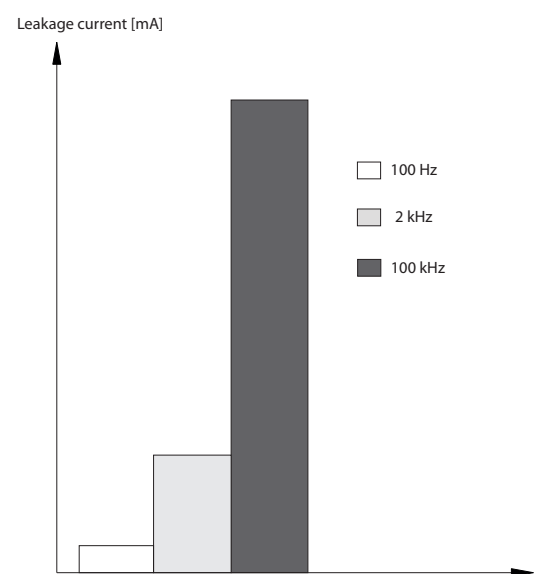

1308B957.11

Illustration 3.9 Influence of the RCD Cut-off Frequency on Leakage Current

3.3 Energy Efficiency

The standard *EN 50598 Ecodesign for power drive systems, motor starters, power electronics and their driven applications* provides guidelines for assessing the energy efficiency of frequency converters.

The standard provides a neutral method for determining efficiency classes and power losses at full load and at part load. The standard allows combination of any motor with any frequency converter.

3

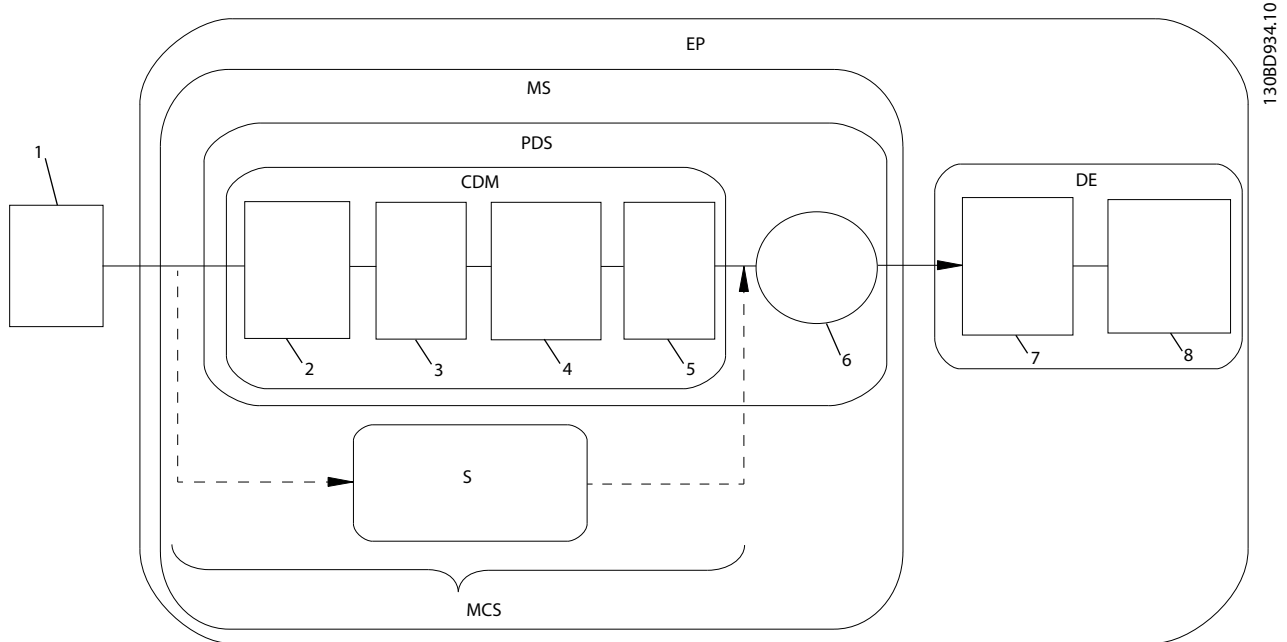

130BD934.10

1	Mains and mains cabling	EP	Extended product
2	Feeding section	MS	Motor system
3	Auxiliaries	PDS	Power drive system
4	Basic drive module (BDM)	CDM	Complete drive module
5	Auxiliaries	DE	Driven equipment
6	Motor	MCS	Motor control system (CDM or starter)
7	Transmission	S	Motor starter
8	Load machine	-	-

Illustration 3.10 Power Drive System (PDS) and Complete Drive Module (CDM)

3.3.1 IE and IES Classes

Complete drive modules

According to the standard EN 50598-2, the complete drive module (CDM) comprises the frequency converter, its feeding section, and its auxiliaries.

Energy efficiency classes for the CDM:

- IE0 = below state of the art.
- IE1 = state of the art.
- IE2 = above state of the art.

Danfoss frequency converters fulfil energy efficiency class IE2. The energy efficiency class is defined at the nominal point of the CDM.

Power drive systems

A power drive system (PDS) consists of a complete drive module (CDM) and a motor.

Energy efficiency classes for the PDS:

- IES0 = Below state of the art.
- IES1 = State of the art.
- IES2 = Above state of the art.

Depending on the motor efficiency, motors driven by a Danfoss VLT® frequency converter typically fulfil energy efficiency class IES2.

The energy efficiency class is defined at the nominal point of the PDS and can be calculated based on the CDM and the motor losses.

3.3.2 Power Loss Data and Efficiency Data

The power loss and the efficiency of a frequency converter depend on configuration and auxiliary equipment. Danfoss provides configuration-specific power loss and efficiency data at the operating points shown in *Illustration 3.11*. The frequency and load define an operating point.

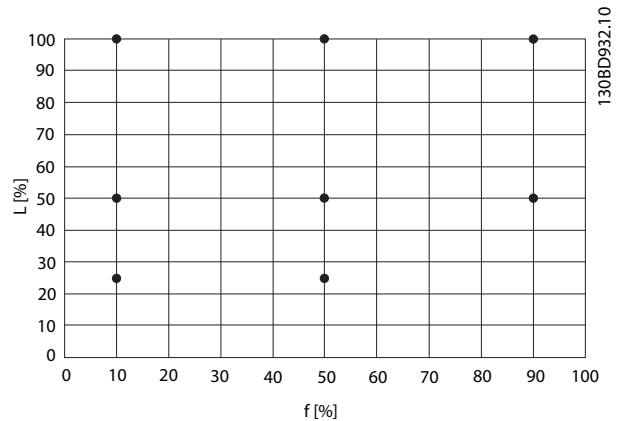

Illustration 3.11 Frequency Converter Operating Points According to EN 50598-2, Load (L) [%] versus Frequency (f) [%]

The power loss data are provided in % of rated apparent output power, and are determined according to EN 50598-2. When the power loss data are determined, the frequency converter uses the factory settings except for the motor data which is required to run the motor.

Refer to www.danfoss.com/vltenergyefficiency for the power loss and efficiency data of the frequency converter at the operating points specified in *Illustration 3.11*.

Use the VLT® ecoSmart application to calculate IE and IES efficiency classes. The application is available at vlt-ecosmart.danfoss.com.

Example of available data

The following example shows power loss and efficiency data for a frequency converter with the following characteristics:

- Power rating 55 kW, rated voltage at 400 V.
- Rated apparent power, S_r , 67.8 kVA.
- Rated output power, P_{CDM} , 59.2 kW.
- Rated efficiency, η_r , 98.3%.

Illustration 3.12 and *Illustration 3.13* show the power loss and efficiency curves. The speed is proportional to the frequency.

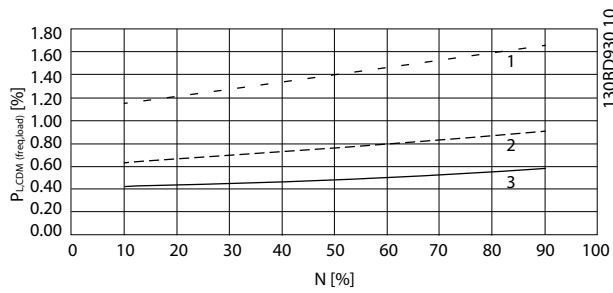

1	100% load
2	50% load
3	25% load

Illustration 3.12 Frequency converter power loss data.
CDM relative losses ($P_{L, CDM}$) [%] versus speed (n) [% of nominal speed].

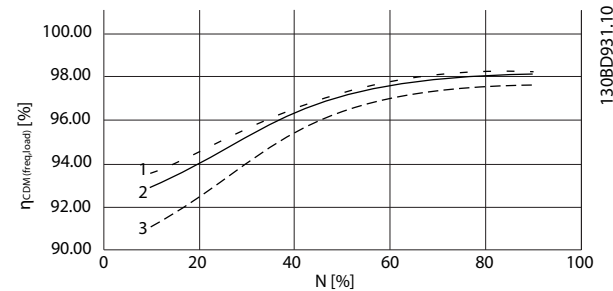

1	100% load
2	50% load
3	25% load

Illustration 3.13 Frequency converter efficiency data.
CDM efficiency ($\eta_{CDM(freq, load)}$) [%] versus speed (n) [% of nominal speed].

Interpolation of power loss

Determine the power loss at an arbitrary operating point using 2-dimensional interpolation.

3.3.3 Losses and Efficiency of a Motor

The efficiency of a motor running at 50–100% of the nominal motor speed and at 75–100% of the nominal torque is practically constant. This is valid both when the frequency converter controls the motor, or when the motor runs directly on mains.

The efficiency depends on the type of motor and the level of magnetisation.

For more information about motor types, refer to the motor technology brochure at www.vlt-drives.danfoss.com.

Switching frequency

The switching frequency influences magnetisation losses in the motor and switching losses in the frequency converter, as shown in *Illustration 3.14*.

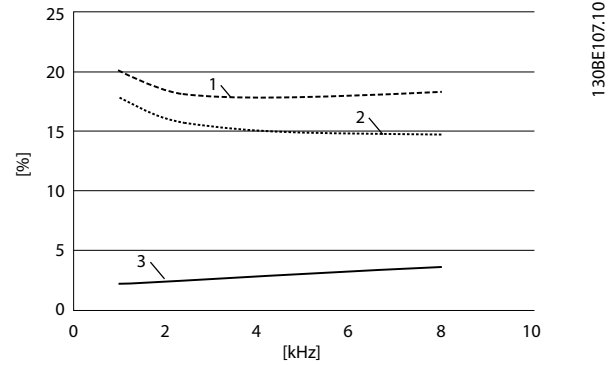

1	Motor and frequency converter
2	Motor only
3	Frequency converter only

Illustration 3.14 Losses [%] versus Switching Frequency [kHz]

NOTICE

A frequency converter produces extra harmonic losses in the motor. These losses decrease when switching frequency increases.

3.3.4 Losses and Efficiency of a Power Drive System

To estimate the power losses at different operating points for a power drive system, sum the power losses at the operating point for each system component:

- Frequency converter.
- Motor.
- Auxiliary equipment.

3.4 Mains Integration

3.4.1 Mains Configurations and EMC Effects

There are several types of AC mains systems for supplying power to frequency converters. Each affects the EMC characteristics of the system. The 5-wire TN-S systems are regarded as best for EMC, while the isolated IT system is the least desirable.

System type	Description
TN Mains Systems	There are 2 types of TN mains distribution systems: TN-S and TN-C.
TN-S	A 5-wire system with separate neutral (N) and protective earth (PE) conductors. It provides the best EMC properties and avoids transmitting interference.
TN-C	A 4-wire system with a common neutral and protective earth (PE) conductor throughout the system. The combined neutral and protective earth conductor results in poor EMC characteristics.
TT Mains Systems	A 4-wire system with a grounded neutral conductor and individual grounding of the frequency converter units. It has good EMC characteristics when grounded properly.
IT Mains System	An isolated 4-wire system with the neutral conductor either not grounded or grounded via an impedance.

Table 3.14 AC Mains System Types

3.4.2 Low-frequency Mains Interference

3.4.2.1 Non-sinusoidal Mains Supply

The mains voltage is rarely a uniform sinusoidal voltage with constant amplitude and frequency. This is partly due to loads that draw non-sinusoidal currents from the mains or have non-linear characteristics, such as:

- Computers.
- Television sets.
- Switching power supplies.
- Energy-efficient lamps.
- Frequency converters.

Deviations are unavoidable and permissible within certain limits.

3.4.2.2 EMC Directives Compliance

In most of Europe, the basis for the objective assessment of the quality of mains power is the Electromagnetic Compatibility of Devices Act (EMVG). Compliance with this regulation ensures that all devices and networks connected to electrical distribution systems fulfil their intended purpose without generating problems.

Standard	Definition
EN 61000-2-2, EN 61000-2-4, EN 50160	Defines the mains voltage limits to observe in public and industrial power grids.
EN 61000-3-2, 61000-3-12	Regulates mains interference generated by connected devices.
EN 50178	Monitors electronic equipment for use in power installations.

Table 3.15 EN Design Standards for Mains Power Quality

3.4.2.3 Interference-free Frequency Converters

Every frequency converter generates mains interference. Present standards only define frequency ranges up to 2 kHz. Some frequency converters shift the mains interference in the region above 2 kHz, which the standard does not address, and labels them as interference-free. Limits for this region are currently being studied. Frequency converters do not shift mains interference.

3.4.2.4 How Mains Interference Occurs

Mains interference distortion of the sinusoidal waveform caused by the pulsating input currents is referred to as harmonics. Derived from Fourier analysis, it is assessed up to 2.5 kHz, corresponding to the 50th harmonic of the mains frequency.

The input rectifiers of frequency converters generate this typical form of harmonic interference on the mains. When frequency converters are connected to 50 Hz mains systems, the 3rd harmonic (150 Hz), 5th harmonic (250 Hz) or 7th harmonic (350 Hz) show the strongest effects. The overall harmonic content is called the total harmonic distortion (THD).

3.4.2.5 Effects of Mains Interference

Harmonics and voltage fluctuations are 2 forms of low-frequency mains interference. They have a different appearance at their origin than at any other point in the mains system when a load is connected. So, a range of influences must be determined collectively when assessing the effects of mains interference. These influences include the mains feed, structure, and loads.

Undervoltage warnings and higher functional losses can occur as a result of mains interference.

Undervoltage warnings

- Incorrect voltage measurements due to distortion of the sinusoidal mains voltage.
- Cause incorrect power measurements because only RMS-true measuring takes harmonic content into account.

Higher losses

- Harmonics reduce the active power, apparent power, and reactive power.
- Distort electrical loads resulting in audible interference in other devices, or, in worst case, even destruction.
- Shorten the lifetime of devices as a result of heating.

NOTICE

Excessive harmonic content puts a load on power factor correction equipment and may even cause its destruction. For this reason, provide chokes for power factor correction equipment when excessive harmonic content is present.

3.4.3 Analysing Mains Interference

To avoid impairment of mains power quality, various methods are available for analysing systems or devices that generate harmonic currents. Mains analysis programs, such as harmonic calculation software (HCS), analyse system designs for harmonics. Specific countermeasures can be tested beforehand and ensure subsequent system compatibility.

For analysing mains systems, go to <http://www.danfoss-hcs.com/Default.asp?LEVEL=START> for software download.

NOTICE

Danfoss has a high level of EMC expertise and provides EMC analyses with detailed evaluation or mains calculations to customers in addition to training courses, seminars, and workshops.

3.4.4 Options for Reducing Mains Interference

Generally speaking, mains interference from frequency converters is reduced by limiting the amplitude of pulsed currents. This reduction improves the power factor λ (lambda).

Several methods are recommended to avoid mains harmonics:

- Input chokes or DC-link chokes in the frequency converters.
- Passive filters.
- Active filters.
- Slim DC links.
- Active front end and low harmonic drives.
- Rectifiers with 12, 18, or 24 pulses per cycle.

3.4.5 Radio Frequency Interference

Frequency converters generate radio frequency interference (RFI) due to their variable-width current pulses. Frequency converters and motor cables radiate these components and conduct them into the mains system.

RFI filters are used to reduce this interference on the mains. They provide noise immunity to protect devices against high-frequency conducted interference. They also reduce interference emitted to the mains cable or radiation from the mains cable. The filters are intended to limit interference to a specified level. Built-in filters are often standard equipment rated for specific immunity.

NOTICE

All VLT[®] Refrigeration Drive FC 103 frequency converters are equipped with integrated mains interference chokes as standard.

3.4.6 Classification of the Operating Site

Knowing the requirements for the environment the frequency converter is intended to operate in is the most important factor regarding EMC compliance.

3.4.6.1 Environment 1/Class B: Residential

Operating sites connected to the public low-voltage power grid, including light industrial areas, are classified as Environment 1/Class B. They do not have their own high voltage or medium-voltage distribution transformers for a separate mains system. The environment classifications apply both inside and outside buildings. Some general examples are:

- Business areas.
- Residential buildings.
- Restaurants.
- Car parks.
- Entertainment facilities.

3.4.6.2 Environment 2/Class A: Industrial

Industrial environments are not connected to the public power grid. Instead, they have their own high voltage or medium-voltage distribution transformers. The environment classifications apply both inside and outside the buildings.

They are defined as industrial and are characterised by specific electromagnetic conditions:

- The presence of scientific, medical, or industrial devices.
- Switching of large inductive and capacitive loads.
- The occurrence of strong magnetic fields (for example, due to high currents).

3.4.6.3 Special Environments

In areas with medium-voltage transformers clearly demarcated from other areas, the user decides which type of environment to classify their facility. The user is responsible for ensuring the electromagnetic compatibility necessary to enable the trouble-free operation of all devices within specified conditions. Some examples of special environments are:

- Shopping centres.
- Supermarkets.
- Filling stations.
- Office buildings.
- Warehouses.

3.4.6.4 Warning Labels

When a frequency converter does not conform to Category C1, provide a warning notice. This is the responsibility of the user. Interference elimination is based on classes A1, A2, and B in EN 55011. The user is ultimately responsible for the appropriate classification of devices and the cost of remedying EMC problems.

3.4.7 Use with Isolated Input Source

Most utility power in the United States is referenced to ground. Although not in common use in the United States, the input power may be an isolated source. All Danfoss frequency converters may be used with isolated input source as well as with ground reference power lines.

3.4.8 Power Factor Correction

Power factor correction equipment serves to reduce the phase shift (φ) between the voltage and the current to move the power factor closer to unity ($\cos \varphi$). This is necessary when many inductive loads, such as motors or lamp ballasts, are used in an electrical distribution system. Frequency converters with an isolated DC link do not draw any reactive power from the mains system or generate any phase power factor correction shifts. They have a $\cos \varphi$ of approximately 1.

For this reason, speed-controlled motors do not have to take into account when dimensioning power factor correction equipment. However, the current drawn by the

phase-correction equipment rises because frequency converters generate harmonics. The load and heat factor on the capacitors increases as the number of harmonic generators increases. As a result, fit chokes in the power factor correction equipment. The chokes also prevent resonance between load inductances and the capacitance. Frequency converters with $\cos \varphi < 1$ also require chokes in the power factor correction equipment. Also consider the higher reactive power level for cable dimensions.

3.4.9 Input Power Delay

To ensure that the input surge suppression circuitry performs correctly, observe a time delay between successive applications of input power.

Table 3.16 shows the minimum time that must be allowed between applications of input power.

Input voltage [V]	380	415	460	600
Waiting time [s]	48	65	83	133

Table 3.16 Input Power Delay

3.4.10 Mains Transients

Transients are brief voltage peaks in the range of a few thousand volts. They can occur in all types of power distribution systems, including industrial and residential environments.

Lightning strikes are a common cause of transients. However, they are also caused by switching large loads on line or off, or switching other mains transients equipment, such as power factor correction equipment. Transients can also be caused by short circuits, tripping of circuit breakers in power distribution systems, and inductive coupling between parallel cables.

EN 61000-4-1 standard describes the forms of these transients and how much energy they contain. There are various ways to limit the harmful effects from transients. Gas-filled surge arresters and spark gaps provide first-level protection against high-energy transients. For second-level protection, most electronic devices, including frequency converters, use voltage-dependent resistors (varistors) to attenuate transients.

3.4.11 Operation with a Standby Generator

Use back-up power systems, when the continued operation is necessary in the event of mains failure. They are also used in parallel with the public power grid to achieve higher mains power. This is common practice for combined heat and power units, taking advantage of the high

efficiency achieved with this form of energy conversion. When a generator provides back-up power, the mains impedance is usually higher than when power is taken from the public grid. This causes the total harmonic distortion to increase. With proper design, generators can operate in a system containing devices that induce harmonics.

When designing a system, consider the use of a stand-by generator.

- When the system is switched from mains operation to generator, the harmonic load usually increases.
- Designers must calculate or measure the increase in the harmonic load to ensure that the power quality conforms to regulations to prevent harmonic problems and equipment failure.
- Avoid asymmetric loading of the generator since it causes increased losses and may increase total harmonic distortion.
- A 5/6 stagger of the generator winding attenuates the 5th and 7th harmonics, but it allows the 3rd harmonic to increase. A 2/3 stagger reduces the 3rd harmonic.
- When possible, the operator should disconnect power factor correction equipment because it causes resonance in the system.
- Chokes or active absorption filters as well as resistive loads operated in parallel can attenuate harmonics.
- Capacitive loads operated in parallel create extra load due to unpredictable resonance effects.

A more precise analysis is possible using mains analysis software, such as HCS. For analysing mains systems, go to <http://www.danfoss-hcs.com/Default.asp?LEVEL=START> for software download.

When operating with harmonic-inducing devices, the maximum loads based on trouble-free facility operation are shown in the harmonic limits table.

Harmonic limits

- B2 and B6 rectifiers⇒maximum 20% of rated generator load.
- B6 rectifier with choke⇒maximum 20–35% of rated generator load, depending on the composition.
- Controlled B6 rectifier⇒maximum 10% of rated generator load.

3.5 Motor Integration

3.5.1 Motor Selection Considerations

The frequency converter can induce electrical stress on a motor. Therefore, consider the following effects on the motor when matching motor with frequency converter:

- Insulation stress
- Bearing stress
- Thermal stress

3.5.2 Sine-wave and dU/dt Filters

Output filters provide benefits to some motors to reduce electrical stress and allow for longer cable length. Output options include sine-wave filters (also called LC filters) and dU/dt filters. The dU/dt filters reduce the sharp rise rate of the pulse. Sine-wave filters smooth the voltage pulses to convert them into a nearly sinusoidal output voltage. With some frequency converters, sine-wave filters comply with EN 61800-3 RFI category C2 for unshielded motor cables, see *chapter 3.8.3 Sine-wave Filters*.

For more information on sine-wave and dU/dt filter options, refer to *chapter 6.2.6 Sine-wave Filters*, *chapter 3.8.3 Sine-wave Filters* and *chapter 6.2.7 dU/dt Filters*.

For more information on sine-wave and dU/dt filter ordering numbers, refer to *chapter 3.8.3 Sine-wave Filters*, and *chapter 6.2.7 dU/dt Filters*.

3.5.3 Proper Motor Grounding

Proper grounding of the motor is imperative for personal safety and to meet EMC electrical requirements for low voltage equipment. Proper grounding is necessary for the effective use of shielding and filters. Design details must be verified for proper EMC implementation.

3.5.4 Motor Cables

Motor cable recommendations and specifications are provided in *chapter 7.5 Cable Specifications*.

All types of 3-phase asynchronous standard motors can be used with a frequency converter unit. The factory setting is for clockwise rotation with the frequency converter output connected as follows.

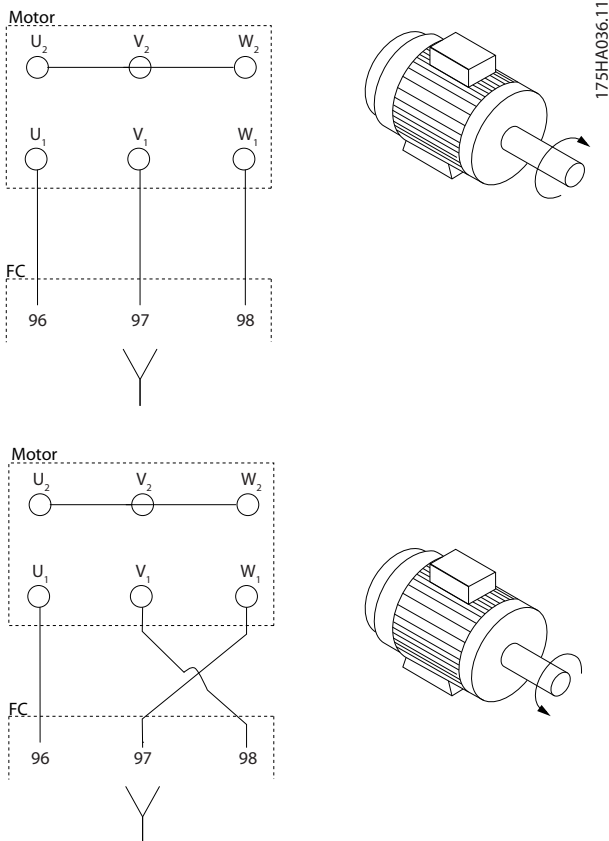

Illustration 3.15 Terminal Connection for Clockwise and Counterclockwise Rotation

Change the direction of rotation by switching 2 phases in the motor cable or by changing the setting of parameter 4-10 Motor Speed Direction.

3.5.5 Motor Cable Shielding

Frequency converters generate steep-edged pulses on their outputs. These pulses contain high-frequency components (extending into the gigahertz range), which cause undesirable radiation from the motor cable. Screened motor cables reduce this radiation.

The purposes of shielding are to:

- Reduce the magnitude of radiated interference.
- Improve the interference immunity of individual devices.

The screen captures the high frequency components and conducts them back to the interference source, in this case the frequency converter. Screened motor cables also provide immunity to interference from nearby external sources.

Even good shielding does not fully eliminate the radiation. System components located in radiation environments must operate without degradation.

3.5.6 Connection of Multiple Motors

NOTICE

Problems may arise at start and at low RPM values if motor sizes are widely different because small motors' relatively high ohmic resistance in the stator calls for a higher voltage at start and at low RPM values.

The frequency converter can control several parallel-connected motors. When using parallel motor connection, observe the following:

- VCC⁺ -mode may be used in some applications.
- The total current consumption of the motors must not exceed the rated output current I_{INV} for the frequency converter.
- Do not use common joint connection for long cable lengths, see *Illustration 3.17*.
- The total motor cable length specified in *Table 3.4*, is valid as long as the parallel cables are kept short (less than 10 m each), see *Illustration 3.19* and *Illustration 3.20*.
- Consider voltage drop across the motor cable, see *Illustration 3.20*.
- For long parallel cables, use an LC filter, see *Illustration 3.20*.
- For long cables without parallel connection, see *Illustration 3.21*.

NOTICE

When motors are connected in parallel, set parameter 1-01 Motor Control Principle to [0] U/f.

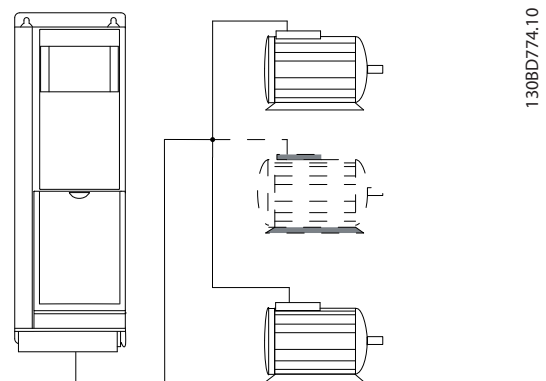

Illustration 3.16 Common Joint Connection for Short Cable Lengths

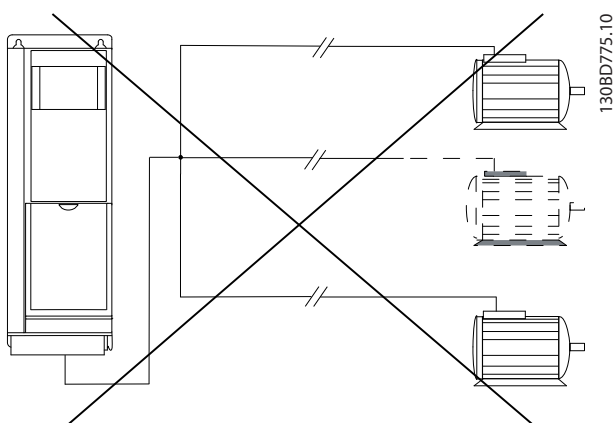

Illustration 3.17 Common Joint Connection for Long Cable Lengths

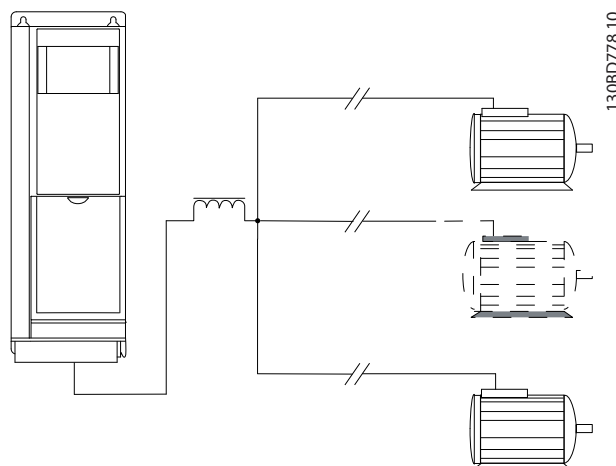

Illustration 3.20 LC Filter for Long Parallel Cables

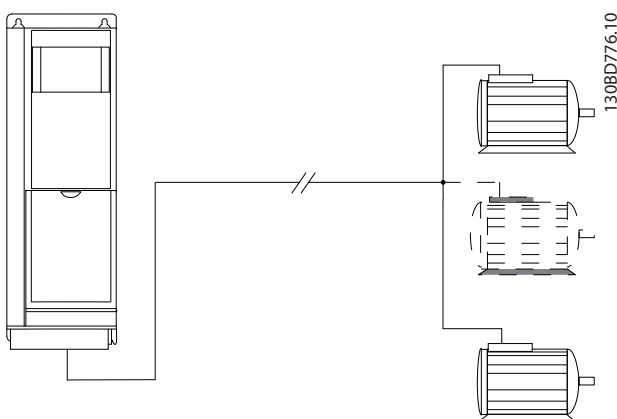

Illustration 3.18 Parallel Cables without Load

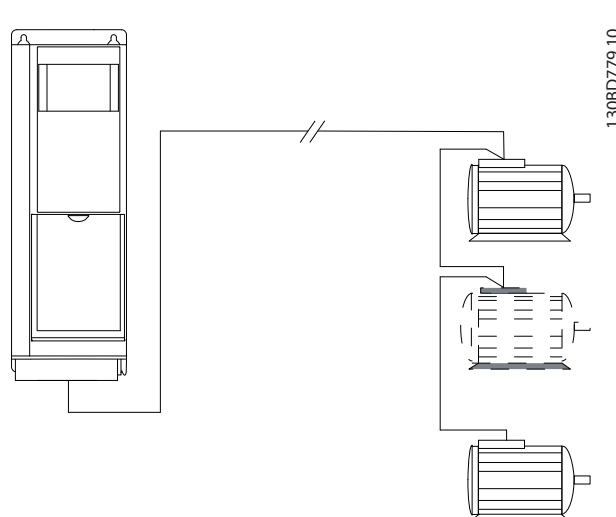

Illustration 3.21 Long Cables in Series Connection

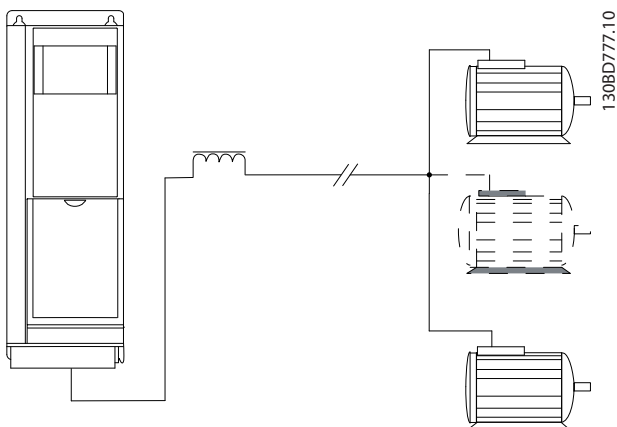

Illustration 3.19 Parallel Cables with Load

Refer to *Table 7.7* for information about cable lengths for multiple parallel motor connections.

3.5.7 Motor Thermal Protection

The frequency converter provides motor thermal protection in several ways:

- Torque limit protects the motor from overload independent of the speed.
- Minimum speed limits the minimum operating speed range, for instance between 30 and 50/60 Hz.
- Maximum speed limits the maximum output speed.
- Input is available for an external thermistor.
- Electronic thermal relay (ETR) for asynchronous motors simulates a bi-metal relay based on

internal measurements. The ETR measures actual current, speed, and time to calculate motor temperature and protect the motor from being overheated by issuing a warning or cutting power to the motor. The characteristics of the ETR are shown in *Illustration 3.22*.

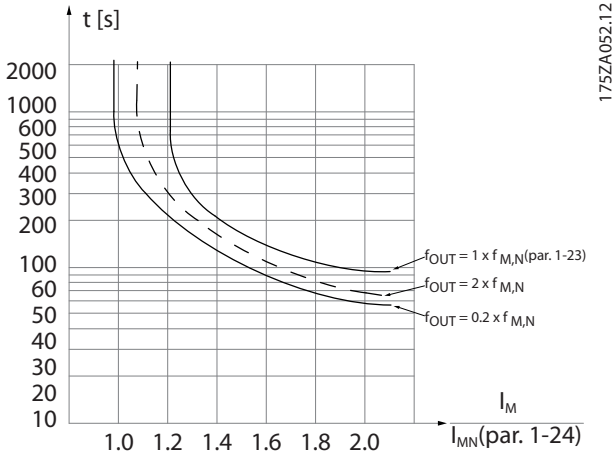

Illustration 3.22 Electronic Thermal Relay Characteristics

The X-axis shows the ratio between I_{motor} and I_{motor} nominal. The Y-axis shows the time in seconds before the ETR cuts off and trips. The curves show the characteristic nominal speed at twice the nominal speed and at 0.2 x the nominal speed.

At lower speed, the ETR cuts off at lower heat due to less cooling of the motor. In that way, the motor is protected from overheating even at low speed. The ETR feature calculates the motor temperature based on actual current and speed.

3.5.8 Output Contactor

Although not generally a recommended practice, operating an output contactor between the motor and the frequency converter does not damage the frequency converter. Closing a previously opened output contactor may connect a running frequency converter to a stopped motor. This may cause the frequency converter to trip and show a fault.

3.5.9 Energy Efficiency

Efficiency of the frequency converter

The load on the frequency converter has little effect on its efficiency.

This also means that the frequency converter efficiency does not change when other U/f characteristics are selected. However, the U/f characteristics do influence the efficiency of the motor.

The efficiency declines a little when the switching frequency is set to a value above 5 kHz. The efficiency is

also slightly reduced when the motor cable is longer than 30 m.

Efficiency calculation

Calculate the efficiency of the frequency converter at different loads based on *Illustration 3.23*. Multiply the factor in this graph with the specific efficiency factor listed in *chapter 7.1 Electrical Data*.

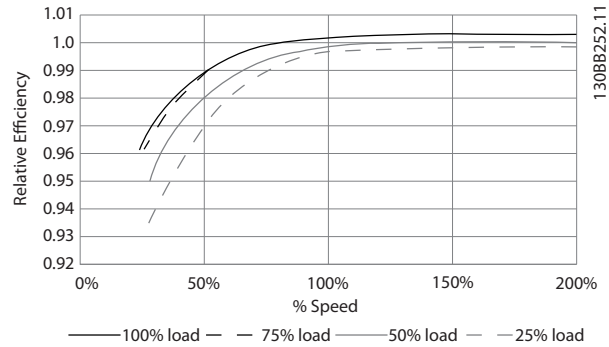

Illustration 3.23 Typical Efficiency Curves

Example: Assume a 55 kW, 380–480 V AC frequency converter with 25% load at 50% speed. The graph is showing 0.97 rated efficiency for a 55 kW frequency converter is 0.98. The actual efficiency is then: $0.97 \times 0.98 = 0.95$.

Motor efficiency

The efficiency of a motor connected to the frequency converter depends on magnetising level. The efficiency of the motor depends on the type of motor.

- In the range of 75–100% of the rated torque, the efficiency of the motor is practically constant, both when controlled by the frequency converter and when running directly on mains.
- The influence from the U/f characteristic on small motors is marginal. However, in motors from 11 kW and up, the efficiency advantage is significant.
- The switching frequency does not affect the efficiency of small motors. Motors from 11 kW and up have their efficiency improved 1–2%. This is because the sine-shape of the motor current is almost perfect at high switching frequency.

System efficiency

To calculate the system efficiency, multiply the efficiency of the frequency converter by the efficiency of the motor.

3.6 Additional Inputs and Outputs

3.6.1 Wiring Schematic

When wired and properly programmed, the control terminals provide:

- Feedback, reference, and other input signals to the frequency converter.
- Output status and fault conditions from the frequency converter.
- Relays to operate auxiliary equipment.
- A serial communication interface.
- 24 V common.

Control terminals are programmable for various functions by selecting parameter options through the local control panel (LCP) on the front of the unit or through external sources. Most control wiring is customer-supplied, unless specified in the factory order.

3

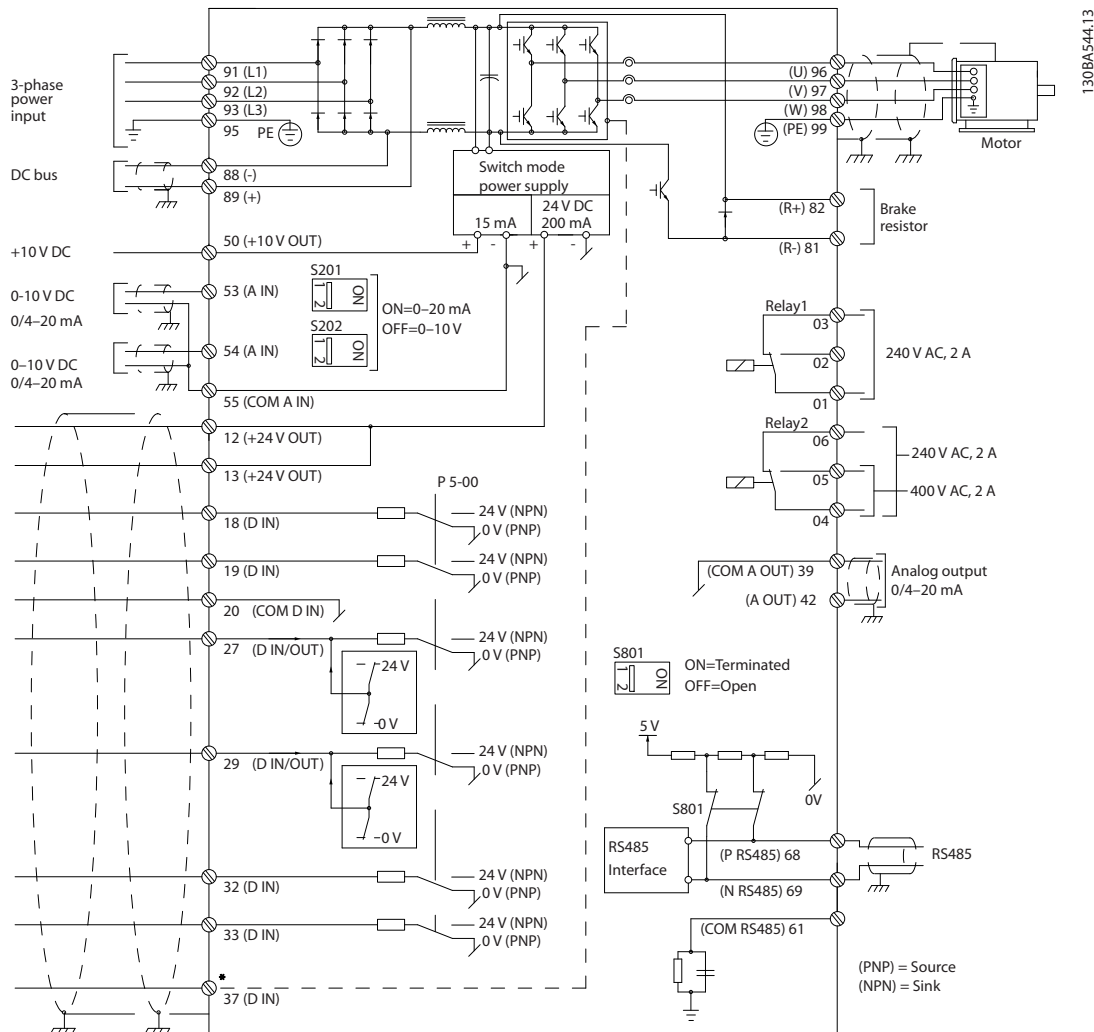

Illustration 3.24 Basic Wiring Schematic

A=Analog, D=Digital

*Terminal 37 (optional) is used for STO. For STO installation instructions, refer to the VLT[®] Frequency Converters - Safe Torque Off Operating Instructions.

**Do not connect cable screen.

3

3.6.2 Relay Connections

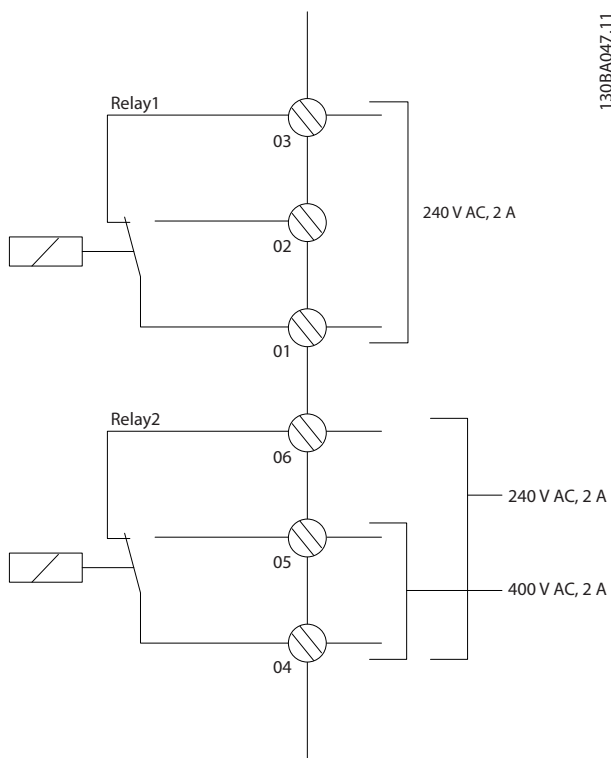

130BA047.11

For more information about relay options, refer to *chapter 3.8 Options and Accessories*.

Relay	Terminal ¹⁾	Description
1	1	Common
	2	Normally open Maximum 240 V
	3	Normally closed Maximum 240 V
2	4	Common
	5	Normally closed Maximum 240 V
	6	Normally closed Maximum 240 V
1	01–02	Make (normally open)
	01–03	Break (normally closed)
2	04–05	Make (normally open)
	04–06	Break (normally closed)

Illustration 3.25 Relay Outputs 1 and 2, Maximum Voltages

1) To add more relay outputs, install VLT® Relay Option Module MCB 105 or VLT® Relay Option Module MCB 113.

For more information about relays, refer to *chapter 7 Specifications* and *chapter 8.3 Relay Terminal Drawings*.

3.6.3 EMC-compliant Electrical Connection

130BD529.12

3

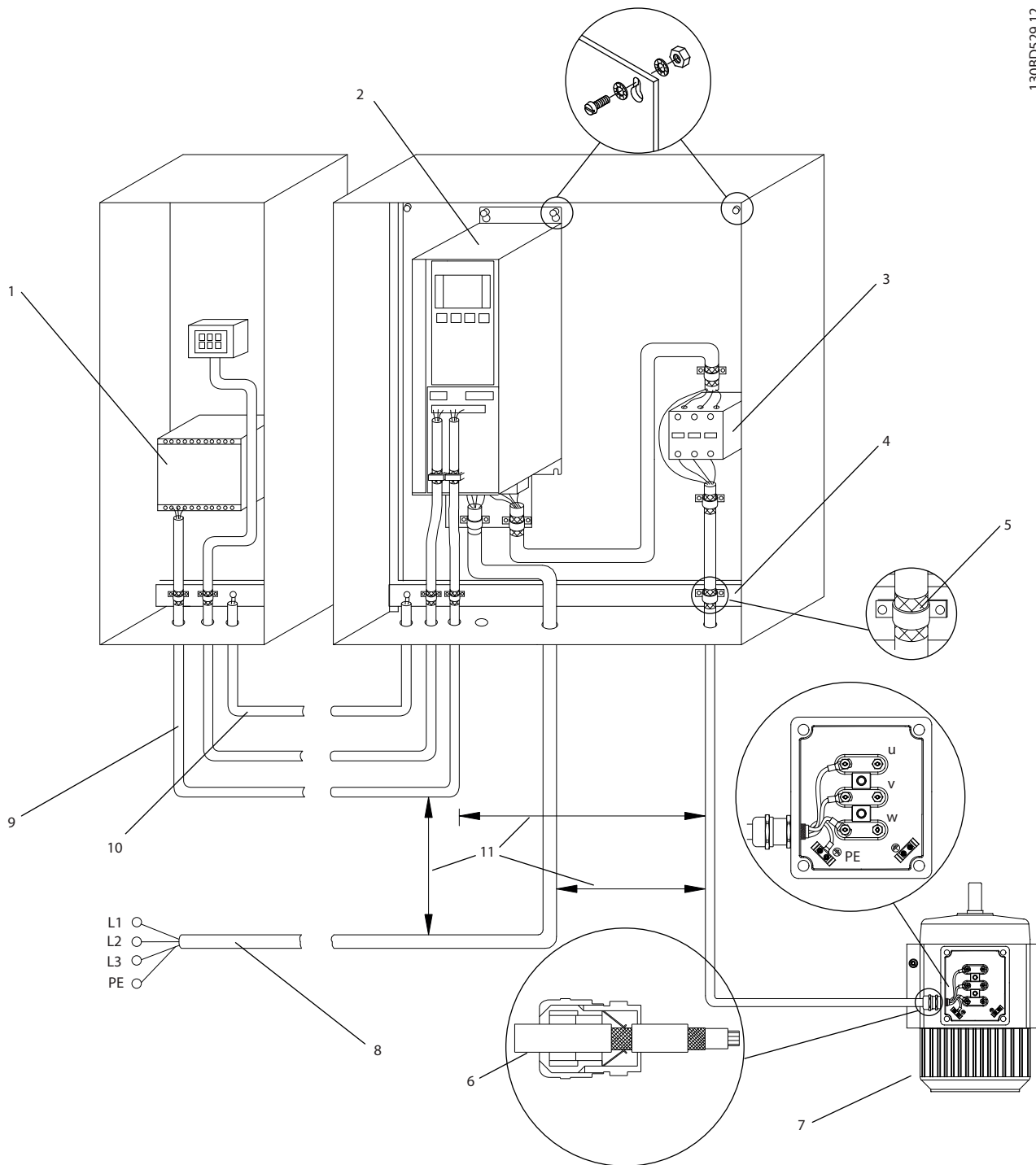

1	PLC	7	Motor, 3-phase, and PE (screened)
2	Frequency converter	8	Mains, 3-phase, and reinforced PE (not screened)
3	Output contactor	9	Control wiring (screened)
4	Cable clamp	10	Potential equalisation minimum 16 mm ² (0.025 in)
5	Cable insulation (stripped)	11	Clearance between control cable, motor cable, and mains cable: Minimum 200 mm
6	Cable gland		

Illustration 3.26 EMC-compliant Electrical Connection

For more information about EMC, see *chapter 2.5.18 EMC Compliance* and *chapter 3.2 EMC, Harmonics, and Ground Leakage Protection*.

NOTICE

EMC INTERFERENCE

Use screened cables for motor and control wiring, and separate cables for input power, motor wiring, and control wiring. Failure to isolate power, motor, and control cables can result in unintended behaviour or reduced performance. Minimum 200 mm (7.9 in) clearance between power, motor, and control cables is required.

3

3.7 Mechanical Planning

3.7.1 Clearance

Side-by-side installation is suitable for all enclosure sizes, except when an IP21/IP4X/TYPE 1 enclosure kit is used (see *chapter 3.8 Options and Accessories*).

Horizontal clearance, IP20

IP20 A and B enclosure sizes can be arranged side-by-side with no clearance. However, the correct mounting order is important. *Illustration 3.27* shows how to mount correctly.

NOTE

For A2 and A3, ensure a clearance between the frequency converters of minimum 40 mm.

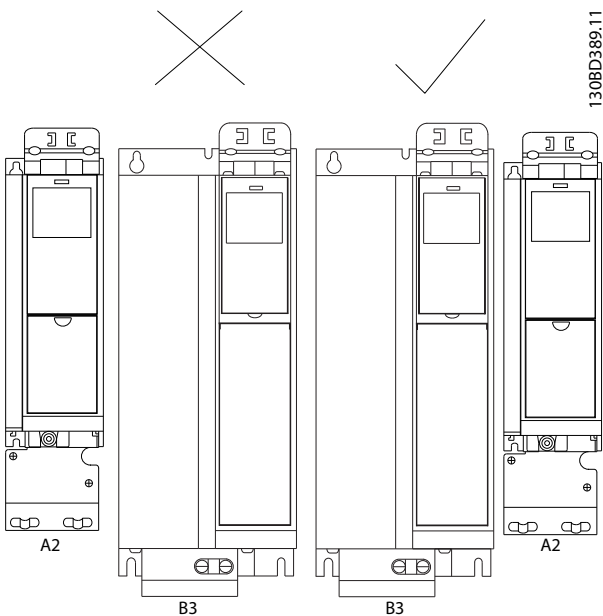

Illustration 3.27 Correct Side-by-side Mounting with no Clearance

Horizontal clearance, IP21 enclosure kit

When the IP21 enclosure kit is used on enclosure sizes A2 or A3, ensure a clearance between the frequency converters of minimum 50 mm.

Vertical clearance

For optimal cooling conditions, ensure vertical clearance for free air passage above and below the frequency converter. See *Illustration 3.28*.

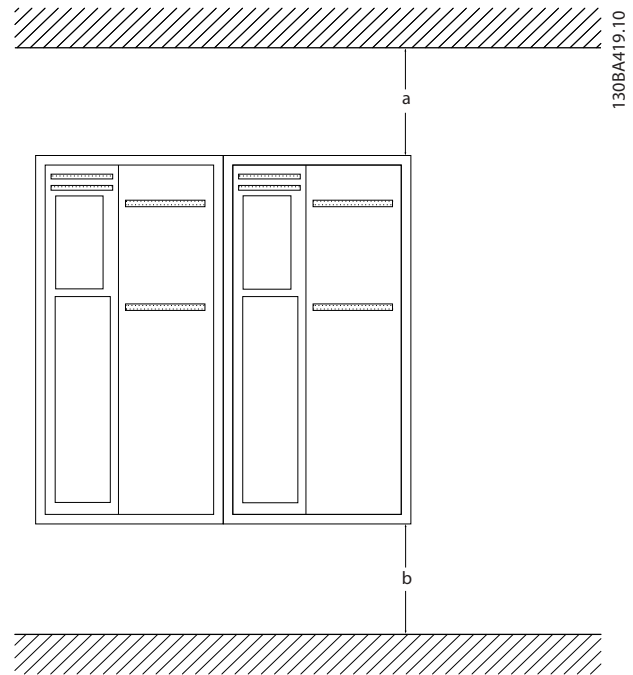

Enclosure size	A2/A3/A4/A5/B1	B2/B3/B4/C1/C3	C2/C4
a [mm]	100	200	225
b [mm]	100	200	225

Illustration 3.28 Vertical Clearance

3.7.2 Wall Mounting

When mounting on a flat wall, no back plate is required.

When mounting on an uneven wall, use a backplate to ensure sufficient cooling air over the heat sink. Use the backplate with enclosures A4, A5, B1, B2, C1, and C2 only.

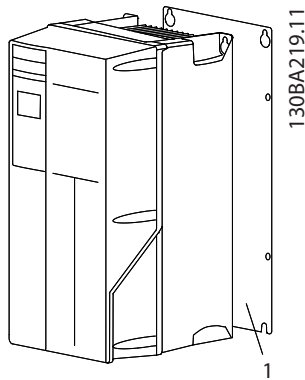

1	Backplate
---	-----------

Illustration 3.29 Mounting with Backplate

For frequency converters with protection rating IP66, use a fibre or nylon washer to protect the epoxy coating.

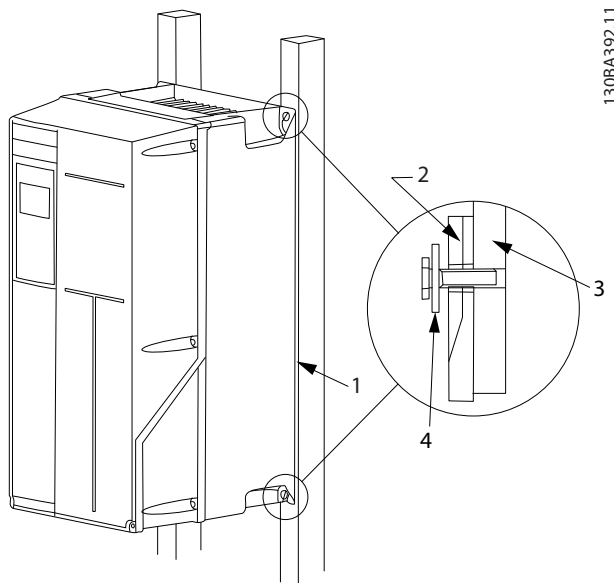

1	Backplate
2	Frequency converter with IP66 enclosure
3	Backplate
4	Fibre washer

Illustration 3.30 Mounting with Backplate for Protection Rating IP66

3.7.3 Access

To plan accessibility for cabling before mounting, refer to the drawings in *chapter 8.1 Mains Connection Drawings* and *chapter 8.2 Motor Connection Drawings*.

3.8 Options and Accessories

Options

For ordering numbers, see *chapter 6 Type Code and Selection*

Mains shielding

- Lexan® shielding mounted in front of incoming power terminals and input plate to protect from contact when the enclosure door is open.

RFI filters

- Frequency converter feature integrated Class A2 RFI filters as standard. If more levels of RFI/EMC protection are required, they can be obtained using optional Class A1 RFI filters, which provide suppression of radio frequency interference and electromagnetic radiation in accordance with EN 55011.

Residual current device (RCD)

Uses the core balance method to monitor ground fault currents in grounded and high-resistance grounded systems (TN and TT systems in IEC terminology). There is a pre-warning (50% of main alarm setpoint) and a main alarm setpoint. Associated with each setpoint is an SPDT alarm relay for external use, which requires an external *window-type* current transformer (supplied and installed by the customer).

- Integrated into the frequency converter's safe torque off circuit.
- IEC 60755 Type B device monitors pulsed DC, and pure DC ground fault currents.
- LED bar graph indicator of the ground fault current level from 10–100% of the setpoint.
- Fault memory.
- TEST/RESET key.

Insulation resistance monitor (IRM)

Monitors the insulation resistance in ungrounded systems (IT systems in IEC terminology) between the system phase conductors and ground. There is an ohmic pre-warning and a main alarm setpoint for the insulation level. Associated with each setpoint is an SPDT alarm relay for external use.

NOTICE

Only 1 insulation resistance monitor can be connected to each ungrounded (IT) system.

- Integrated into the frequency converter's safe torque off circuit.
- LCD display of insulation resistance.
- Fault memory.

- INFO, TEST, and RESET keys.

Fuses

- Fuses are recommended for fast-acting current-overload protection of the frequency converter. Fuse protection limits frequency converter damage and minimises service time in the event of a failure. Fuses are required to meet marine certification.

Disconnect

- A door-mounted handle allows for the manual operation of a power disconnect switch to enable and disable power to the frequency converter, increasing safety during servicing. The disconnect is interlocked with the enclosure doors to prevent them from being opened while power is still applied.

Circuit breakers

- A circuit breaker can be remotely tripped but must be manually reset. Circuit breakers are interlocked with the enclosure doors to prevent them from being opened while power is still applied. When a circuit breaker is ordered as an option, fuses are also included for fast-acting current overload protection of the frequency converter.

Contactors

- An electrically controlled contactor switch allows for the remote enabling and disabling of power to the frequency converter. If the IEC emergency stop option is ordered, the Pilz Safety monitors an auxiliary contact on the contactor.

Manual motor starters

Provide 3-phase power for electric cooling blowers often required for larger motors. Power for the starters is provided from the load side of any supplied contactor, circuit breaker, or disconnect switch and from the input side of the Class 1 RFI filter (optional). Power is fused before each motor starter, and is off when the incoming power to the frequency converter is off. Up to 2 starters are allowed (1 if a 30 A, fuse-protected circuit is ordered). Motor starters are integrated into the frequency converter's Safe Torque Off circuit.

Unit features include:

- Operation switch (on/off).
- Short circuit and overload protection with test function.
- Manual reset function.

30 A, fuse-protected terminals

- 3-phase power matching incoming mains voltage for powering auxiliary customer equipment.
- Not available if 2 manual motor starters are selected.

- Terminals are off when the incoming power to the frequency converter is off.

- Power for the fuse-protected terminals is provided from the load side of any supplied contactor, circuit breaker, or disconnect switch, and from the input side of the Class 1 RFI filter (optional).

24 V DC supply

- 5 A, 120 W, 24 V DC.
- Protected against output overcurrent, overload, short circuits, and overtemperature.
- For powering customer-supplied accessory devices such as sensors, PLC I/O, contactors, temperature probes, indicator lights, and/or other electronic hardware.
- Diagnostics include a dry DC-ok contact, a green DC-ok LED, and a red overload LED.

External temperature monitoring

- Designed for monitoring temperatures of external system components, such as the motor windings and/or bearings. Includes 8 universal input modules plus 2 dedicated thermistor input modules. All 10 modules are integrated into the STO circuit and can be monitored via a fieldbus network (requires the purchase of a separate module/bus coupler). Order an STO brake option to select external temperature monitoring.

Serial communications

VLT® PROFIBUS DP-V1 MCA 101

- PROFIBUS DP-V1 gives wide compatibility, a high level of availability, support for all major PLC vendors, and compatibility with future versions.
- Fast, efficient communication, transparent installation, advanced diagnosis, and parameterisation and auto-configuration of process data via GSD file.
- Acyclic parameterisation using PROFIBUS DP-V1, PROFIdrive, or Danfoss FC profile state machines, PROFIBUS DP-V1, master class 1 and 2.
- Ordering numbers:
 - 130B1100 uncoated.
 - 130B1200 coated (Class G3/ISA S71.04-1985).

VLT® LonWorks for ADAP-KOOL® MCA 107

- Continuous exchange of messages between a number of processors.
- Enables direct communication between individual network devices.

VLT® PROFINET MCA 120

The PROFINET option offers connectivity to PROFINET-based networks via the PROFINET protocol. The option is able to handle a single connection with an actual packet interval down to 1 ms in both directions.

- Built-in web server for remote diagnosis and reading out of basic frequency converter parameters.
- If certain warnings or alarms occur, or have cleared again, an e-mail notification can be configured for sending an e-mail message to 1 or several receivers.
- TCP/IP for easy access to frequency converter configuration data from MCT 10 Set-up Software.
- FTP (File Transfer Protocol) file upload and download.
- Support of DCP (discovery and configuration protocol).

More options**VLT® General Purpose I/O MCB 101**

The I/O option offers an extended number of control inputs and outputs.

- 3 digital inputs 0–24 V: Logic 0 < 5 V; Logic 1 > 10 V.
- 2 analog inputs 0–10 V: Resolution 10 bit plus sign.
- 2 digital outputs NPN/PNP push-pull.
- 1 analog output 0/4–20 mA.
- Spring-loaded connection.
- Separate parameter settings.
- Ordering numbers:
 - 130B1125 uncoated.
 - 130B1212 coated (Class G3/ISA S71.04-1985).

VLT® Relay Option MCB 105

Enables extending relay functions with 3 extra relay outputs.

- Maximum terminal load: AC-1 resistive load: 240 V AC, 2 A, AC-15 .
- Inductive load @cos ϕ 0.4: 240 V AC, 0.2 A, DC-1.
- Resistive load: 24 V DC, 1 A, DC-13 .
- Inductive load: @cos ϕ 0.4: 24 V DC, 0.1 A.
- Minimum terminal load: DC 5 V: 10 mA.
- Maximum switch rate at rated load/minimum load: 6 min-1/20 s-1.
- Ordering numbers:
 - 130B1110 uncoated.
 - 130B1210 coated (Class G3/ISA S71.04-1985).

VLT® Analog I/O Option MCB 109

This analog input/output option is easily fitted in the frequency converter for upgrading to advanced performance and control using the additional inputs/outputs. This option also upgrades the frequency converter with a battery back-up supply for the clock built into the frequency converter. This provides stable use of all frequency converter clock functions as timed actions.

- 3 analog inputs, each configurable as both voltage and temperature input.
- Connection of 0–10 V analog signals as well as PT1000 and NI1000 temperature inputs.
- 3 analog outputs each configurable as 0–10 V outputs.
- Included back-up supply for the standard clock function in the frequency converter. The back-up battery typically lasts for 10 years, depending on the environment.
- Ordering numbers:
 - 130B1143 uncoated
 - 130B1243 coated (Class G3/ISA S71.04-1985)

VLT® Extended Relay Card MCB 113

The Extended Relay Card MCB 113 adds inputs/outputs to the frequency converter for increased flexibility.

- 7 digital inputs.
- 2 analog outputs.
- 4 SPDT relays.
- Meets NAMUR recommendations.
- Galvanic isolation capability.
- Ordering numbers:
 - 130B1164 uncoated.
 - 130B1264 coated.

VLT® 24 V DC Supply Option MCB 107

The option is used to connect an external DC supply to keep the control section and any installed option active when mains power is down.

- Input voltage range: 24 V DC \pm 15% (maximum 37 V in 10 s).
- Maximum input current: 2.2 A.
- Maximum cable length: 75 m.
- Input capacitance load: <10 μ F.
- Power-up delay: <0.6 s.
- Easy to install in frequency converters in existing machines.
- Keeps the control board and options active during power cuts.

- Keeps fieldbusses active during power cuts.
- Ordering numbers:
 - 130B1108 uncoated.
 - 130B1208 coated (Class G3/ISA S71.04-1985).

3.8.1 Communication Options

- VLT® PROFIBUS DP-V1 MCA 101
- VLT® AK-LonWorks MCA 107
- VLT® PROFINET MCA 120

For further information, refer to *chapter 7 Specifications*.

3.8.2 Input/Output, Feedback, and Safety Options

- VLT® General Purpose I/O Module MCB 101
- VLT® Relay Card MCB 105
- VLT® Extended Relay Card MCB 113

For further information, refer to *chapter 7 Specifications*.

3.8.3 Sine-wave Filters

When a frequency converter controls a motor, resonance noise is heard from the motor. This noise, which is the result of the motor design, occurs every time an inverter switch in the frequency converter is activated. The frequency of the resonance noise thus corresponds to the switching frequency of the frequency converter.

Danfoss supplies a sine-wave filter to dampen the acoustic motor noise.

The filter reduces the ramp-up time of the voltage, the peak load voltage U_{PEAK} , and the ripple current ΔI to the motor, which means that current and voltage become almost sinusoidal. So, the acoustic motor noise is reduced to a minimum.

The ripple current in the sine-wave filter coils also causes some noise. Solve the problem by integrating the filter in a cabinet or similar.

3.8.4 dU/dt Filters

Danfoss supplies dU/dt filters which are differential-mode, low-pass filters that reduce motor terminal phase-to-phase peak voltages and reduce the rise time to a level that lowers the stress on the insulation at the motor windings. This is especially an issue with short motor cables.

Compared to sine-wave filters (see *chapter 3.8.3 Sine-wave Filters*), the dU/dt filters have a cut-off frequency above the switching frequency.

3.8.5 Harmonic Filters

The VLT® Advanced Harmonic Filter AHF 005 and AHF 010 are advanced harmonic filters, not to be compared with traditional harmonic trap filters. The Danfoss harmonic filters have been specially designed to match the Danfoss frequency converters.

Connecting the Danfoss harmonic filters AHF 005 or AHF 010 in front of a Danfoss frequency converter reduces the total harmonic current distortion generated back to the mains to 5% and 10%.

3.8.6 IP21/NEMA Type 1 Enclosure Kit

IP20/IP4X top/NEMA TYPE 1 is an optional enclosure element available for IP20 compact units. If the enclosure kit is used, an IP20 unit is upgraded to comply with enclosure IP21/4X top/TYPE 1.

The IP4X top can be applied to all standard IP20 FC 103 variants.

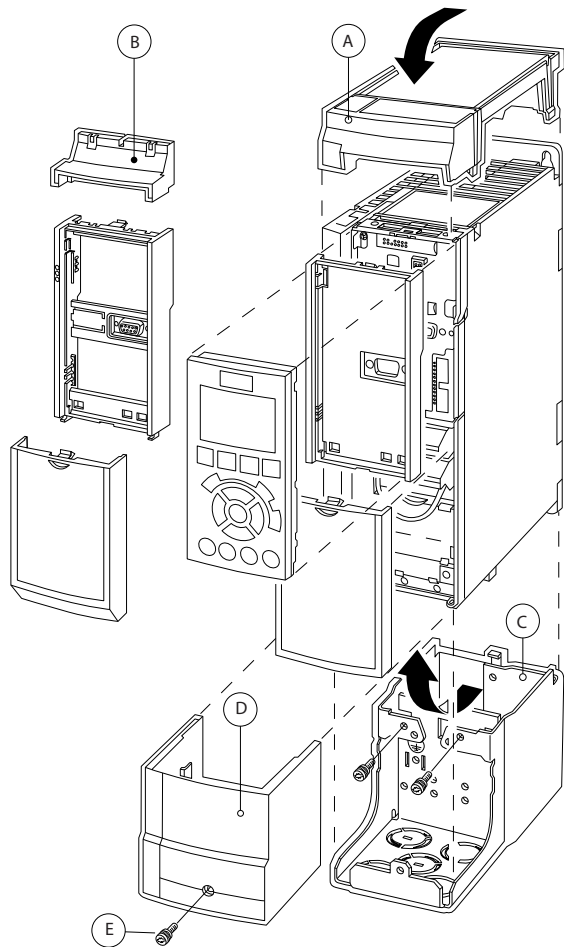
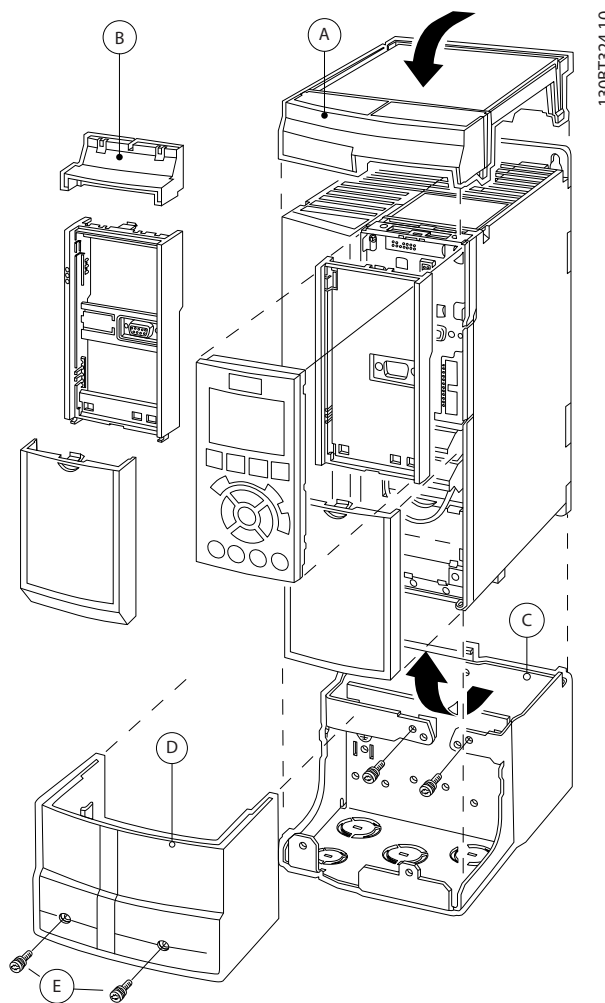

Illustration 3.31 Enclosure Size A2



A	Top cover
B	Brim
C	Base part
D	Base cover
E	Screw(s)

Illustration 3.32 Enclosure Size A3

1. Place the top cover as shown. If an A or B option is used, fit the brim to cover the top inlet.
2. Place the base part C at the bottom of the frequency converter.
3. Use the clamps from the accessory bag to fasten the cables correctly.

Holes for cable glands:

- Size A2: 2x M25 and 3xM32.
- Size A3: 3xM25 and 3xM32.

Enclosure type	Height A [mm]	Width B [mm]	Depth C ¹⁾ [mm]
A2	372	90	205
A3	372	130	205
B3	475	165	249
B4	670	255	246
C3	755	329	337
C4	950	391	337

Table 3.17 Dimensions

1) If option A/B is used, the depth increases (see chapter 7.9 Power Ratings, Weight, and Dimensions for details)

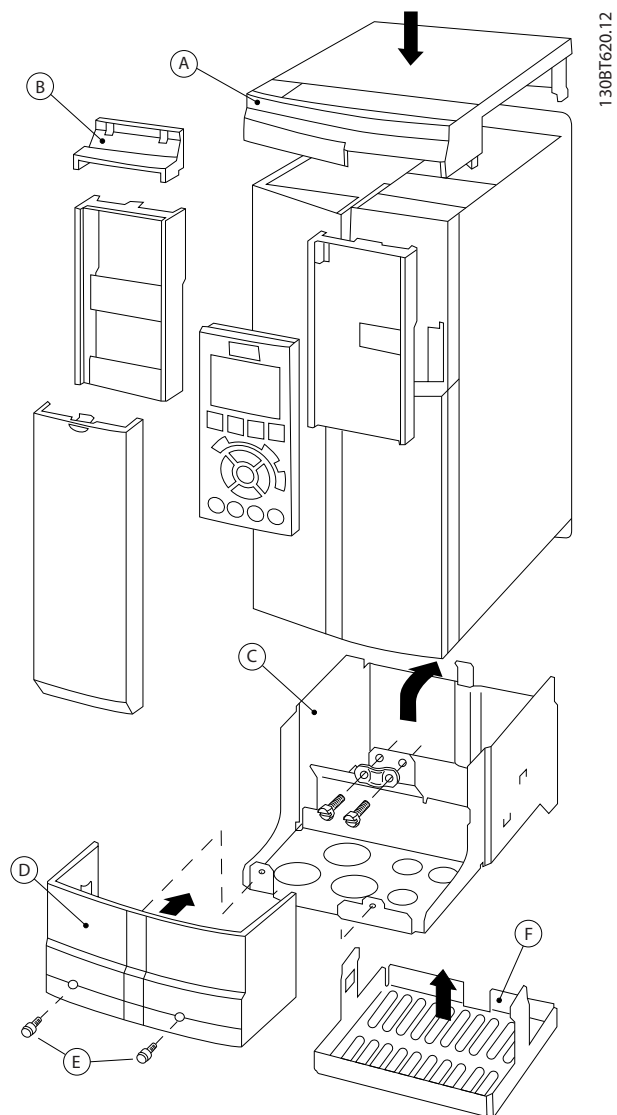

Illustration 3.33 Enclosure Size B3

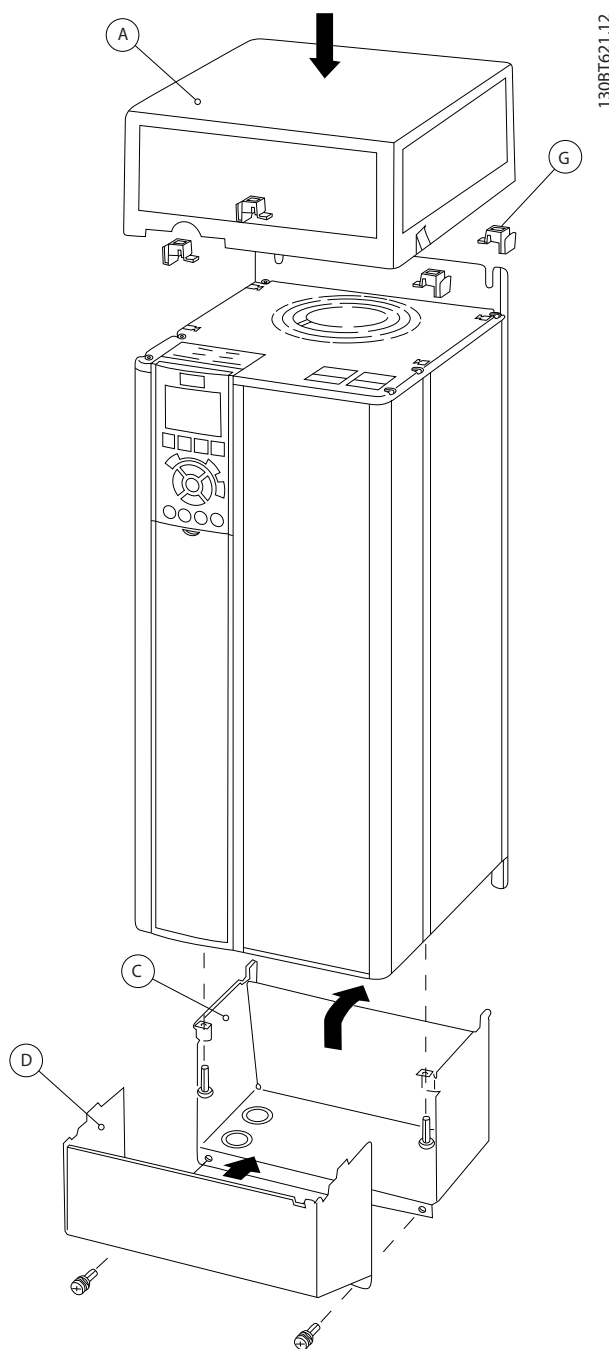

Illustration 3.34 Enclosure Sizes B4, C3, and C4

A	Top cover
B	Brim
C	Base part
D	Base cover
E	Screw(s)
F	Fan cover
G	Top clip

Table 3.18 Legend to Illustration 3.33 and Illustration 3.34

When option module A and/or option module B is/are used, fit the brim (B) to the top cover (A).

NOTICE

Side-by-side installation is not possible when using the IP21/IP4X/TYPE 1 Enclosure Kit

3.8.7 Common-mode Filters

High-frequency common-mode cores (HF-CM cores) reduce electromagnetic interference and eliminate bearing damage by electrical discharge. They are special nanocrystalline magnetic cores, which have superior filtering performance compared to regular ferrite cores. The HF-CM core acts like a common-mode inductor between phases and ground.

Installed around the 3 motor phases (U, V, W), the common mode filters reduce high-frequency common-mode currents. As a result, high-frequency electromagnetic interference from the motor cable is reduced.

The number of cores required depends on motor cable length and frequency converter voltage. Each kit consists of 2 cores. To determine the number of cores required, refer to Table 3.19.

Cable length ¹⁾ [m]	Enclosure size				
	A and B		C		
	T2/T4	T7	T2/T4	T7	T7
50	2	4	2	2	4
100	4	4	2	4	4
150	4	6	4	4	4
300	4	6	4	4	6

Table 3.19 Number of Cores

1) Where longer cables are required, stack more HF-CM cores.

Install the HF-CM cores by passing the 3 motor phase cables (U, V, W) through each core, as shown in Illustration 3.35.

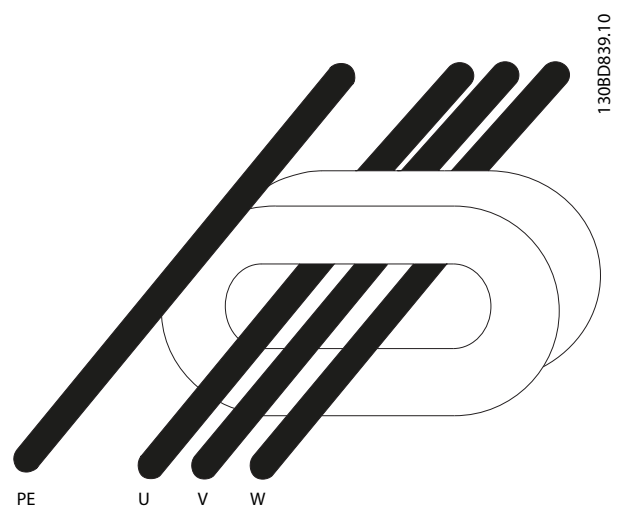

Illustration 3.35 HF-CM Core with Motor Phases

3

3.8.8 Remote Mounting Kit for LCP

The LCP can be moved to the front of an enclosure by using the remote built-in kit. Tighten the fastening screws with a torque of maximum 1 Nm.

The LCP enclosure is rated IP66.

Enclosure	IP66 front
Maximum cable length between LCP and unit	3 m
Communication standard	RS485

Table 3.20 Technical Data

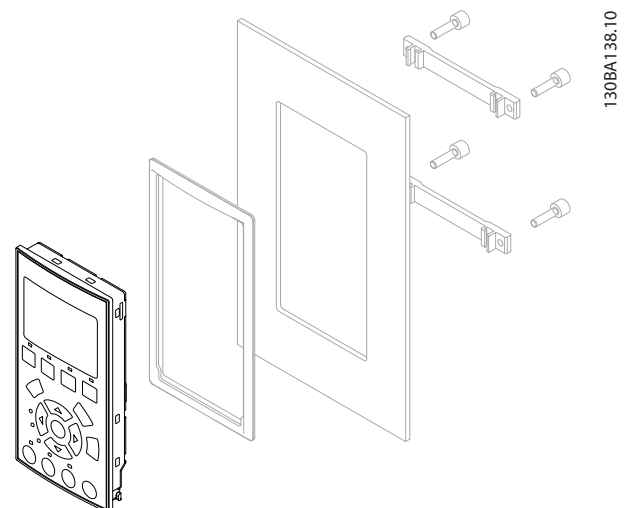
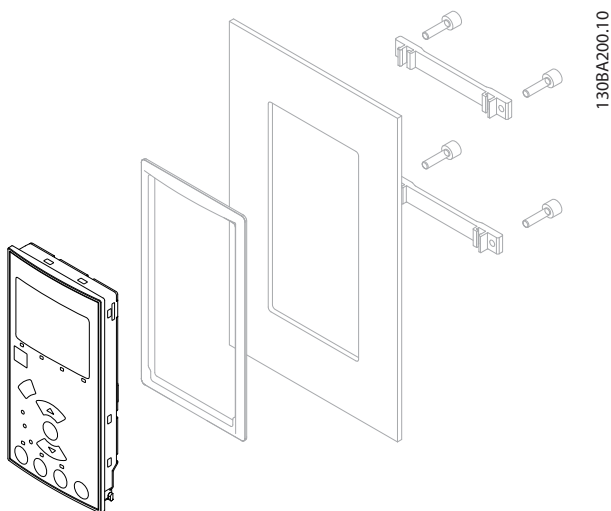

Illustration 3.36 LCP Kit with Graphical LCP, Fasteners, 3 m Cable, and Gasket
Ordering Number 130B1113



130BA200.10

Illustration 3.37 LCP Kit with Numerical LCP, Fasteners, and Gasket
Ordering Number 130B1114

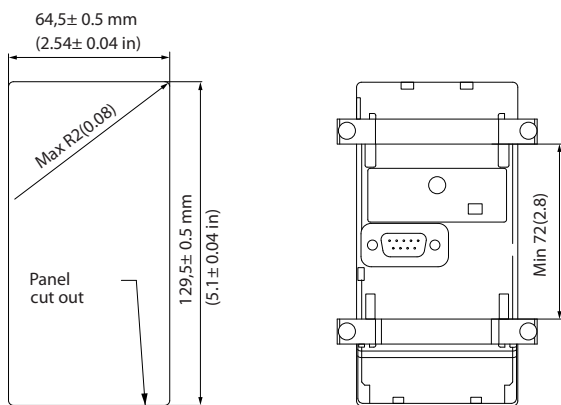

Illustration 3.38 Dimensions of LCP Kit

3.8.9 Mounting Bracket for Enclosure Sizes A5, B1, B2, C1, and C2

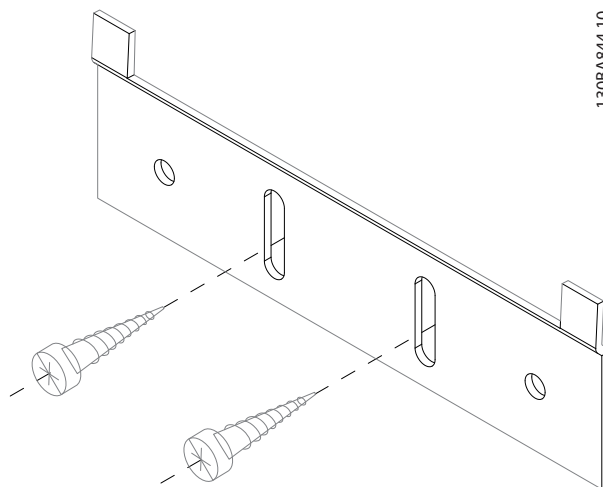

Illustration 3.39 Lower Bracket

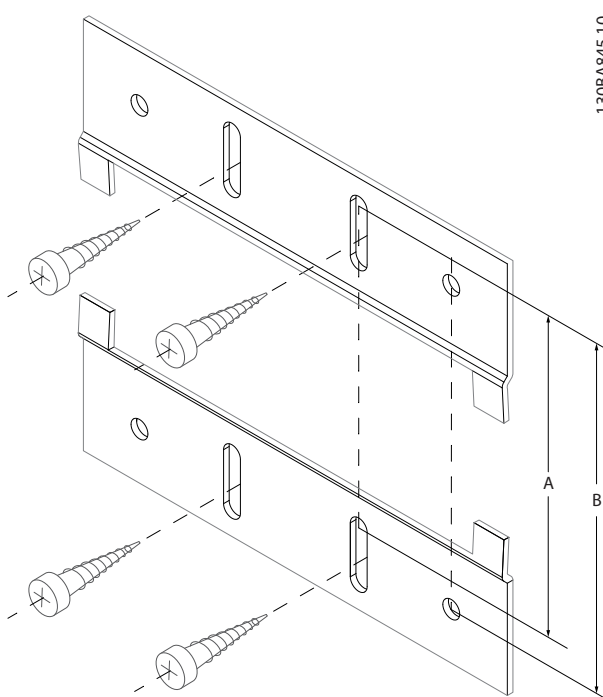

Illustration 3.40 Upper Bracket

See dimensions in Table 3.21.

Enclosure Size	IP	A [mm]	B [mm]	Ordering number
A5	55/66	480	495	130B1080
B1	21/55/66	535	550	130B1081
B2	21/55/66	705	720	130B1082
B3	21/55/66	730	745	130B1083
B4	21/55/66	820	835	130B1084

Table 3.21 Details of Mounting Brackets

3.9 Serial Interface RS485

3.9.1 Overview

RS485 is a 2-wire bus interface compatible with multi-drop network topology. Nodes can be connected as a bus, or via drop cables from a common trunk line. A total of 32 nodes can be connected to 1 network segment.

Repeaters divide network segments, see *Illustration 3.41*.

NOTICE

Each repeater functions as a node within the segment in which it is installed. Each node connected within a given network must have a unique node address across all segments.

Terminate each segment at both ends, using either the termination switch (S801) of the frequency converters or a biased termination resistor network. Always use screened twisted pair (STP) cable for bus cabling, and follow good common installation practice.

Low-impedance ground connection of the screen at every node is important, including at high frequencies. Thus, connect a large surface of the screen to ground, for example, with a cable clamp or a conductive cable gland. It may be necessary to apply potential-equalising cables to maintain the same ground potential throughout the network, particularly in installations with long cables. To prevent impedance mismatch, always use the same type of cable throughout the entire network. When connecting a motor to the frequency converter, always use screened motor cable.

Cable	Screened twisted pair (STP)
Impedance [Ω]	120
Cable length [m]	Maximum 1200 (including drop lines) Maximum 500 station-to-station

Table 3.22 Cable Specifications

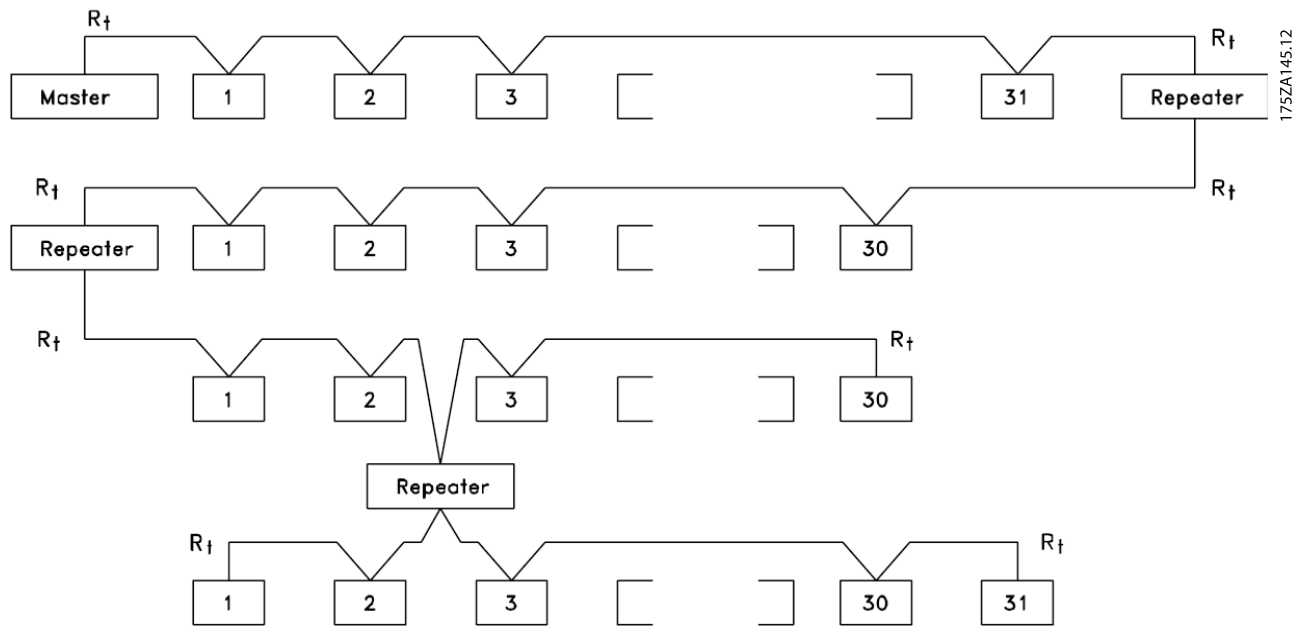

Illustration 3.41 RS485 Bus Interface

		Parameters	
FC		Function	Setting
+24 V	12	Parameter 8-30 Protocol	FC*
+24 V	13	Parameter 8-31 Address	1*
D IN	18	Parameter 8-32 Baud Rate	9600*
D IN	19	* = Default value	
COM	20	Notes/comments:	
D IN	27	Select protocol, address, and baud rate in the above mentioned parameters.	
D IN	29	D IN 37 is an option.	
D IN	32		
D IN	33		
D IN	37		
+10 V	50		
A IN	53		
A IN	54		
COM	55		
A OUT	42		
COM	39		
R1	01, 02, 03		
R2	04, 05, 06		
	61		
	68		
	69		

Table 3.23 RS485 Network Connection

3.9.2 Network Connection

One or more frequency converters can be connected to a control (or master) using the RS485 standardised interface. Terminal 68 is connected to the P signal (TX+, RX+), while terminal 69 is connected to the N signal (TX-, RX-). See drawings in *chapter 3.6.1 Wiring Schematic*.

If more than 1 frequency converter is connected to a master, use parallel connections.

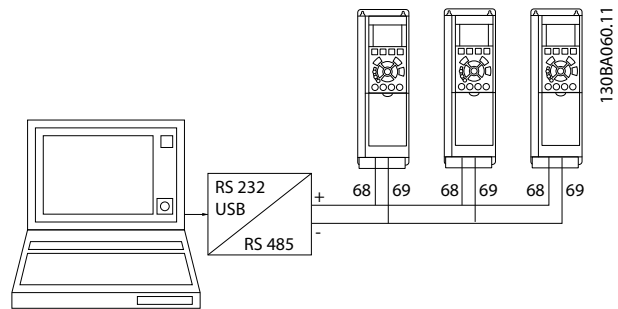

Illustration 3.42 Parallel Connections

To avoid potential equalising currents in the screen, wire according to *Illustration 3.24*.

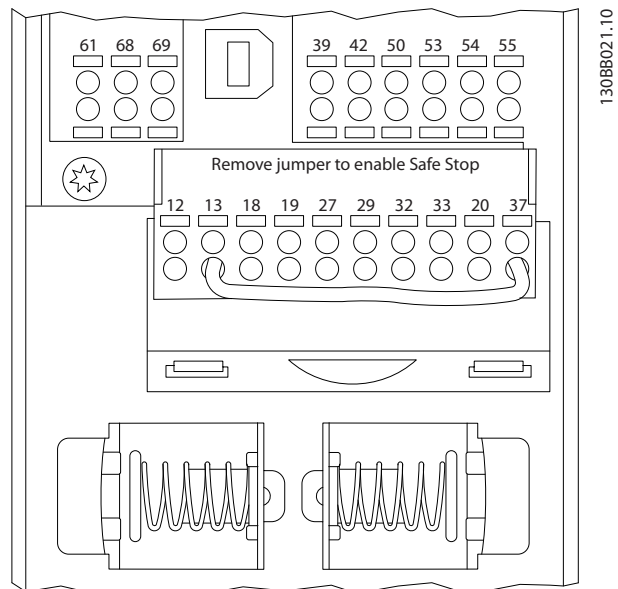

Illustration 3.43 Control Card Terminals

3.9.3 RS485 Bus Termination

Terminate RS485 bus with a resistor network at both ends. For this purpose, set switch S801 on the control card to ON.

Set the communication protocol to *parameter 8-30 Protocol*.

3.9.4 EMC Precautions

The following EMC precautions are recommended to achieve interference-free operation of the RS485 network.

Observe relevant national and local regulations, for example regarding protective earth connection. Keep the RS485 communication cable away from motor and brake resistor cables to avoid coupling of high frequency noise from one cable to another. Normally, a distance of 200 mm (8 inches) is sufficient, but keeping the greatest possible distance between the cables is recommended, especially where cables run in parallel over long distances. When crossing is unavoidable, the RS485 cable must cross motor cables at an angle of 90°.

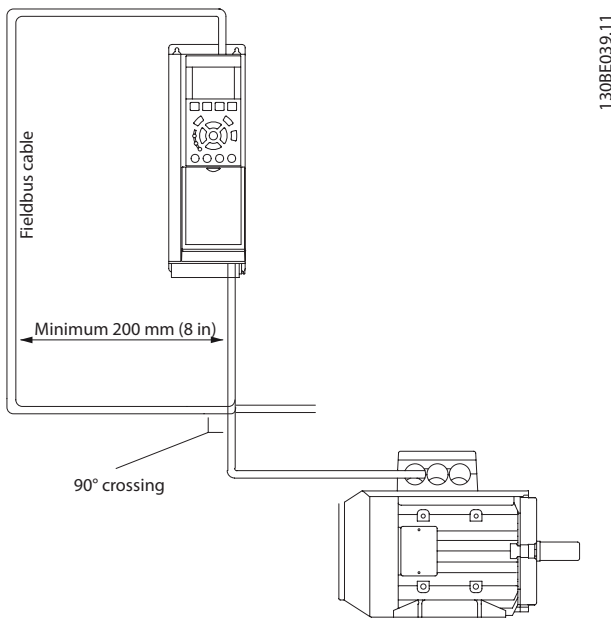

Illustration 3.44 Cable Routing

3.9.5 FC Protocol Overview

The FC protocol, also referred to as FC bus or standard bus, is the Danfoss standard fieldbus. It defines an access technique according to the master/slave principle for communications via a fieldbus.

1 master and a maximum of 126 slaves can be connected to the bus. The master selects the individual slaves via an address character in the telegram. A slave itself can never transmit without first being requested to do so, and direct message transfer between the individual slaves is not possible. Communications occur in the half-duplex mode. The master function cannot be transferred to another node (single-master system).

The physical layer is RS485, thus utilising the RS485 port built into the frequency converter. The FC protocol supports different telegram formats:

- A short format of 8 bytes for process data.
- A long format of 16 bytes that also includes a parameter channel.
- A format used for texts.

3.9.6 Network Configuration

To enable the FC protocol for the frequency converter, set the following parameters:

Parameter number	Setting
Parameter 8-30 Protocol	FC
Parameter 8-31 Address	1–126
Parameter 8-32 Baud Rate	2400–115200
Parameter 8-33 Parity / Stop Bits	Even parity, 1 stop bit (default)

Table 3.24 FC Protocol Parameters

3.9.7 FC Protocol Message Framing Structure

3.9.7.1 Content of a Character (byte)

Each character transferred begins with a start bit. Then 8 data bits are transferred, corresponding to a byte. Each character is secured via a parity bit. This bit is set at 1 when it reaches parity. Parity is when there is an equal number of 1s in the 8 data bits and the parity bit in total. A stop bit completes a character, thus consisting of 11 bits in all.

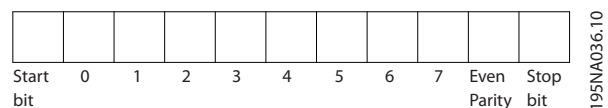

Illustration 3.45 Content of a Character

3.9.7.2 Telegram Structure

Each telegram has the following structure:

- Start character (STX)=02 hex.
- A byte denoting the telegram length (LGE).
- A byte denoting the frequency converter address (ADR).

A number of data bytes (variable, depending on the type of telegram) follows.

A data control byte (BCC) completes the telegram.

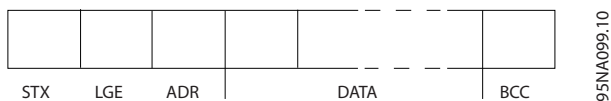

Illustration 3.46 Telegram Structure

3.9.7.3 Telegram Length (LGE)

The telegram length is the number of data bytes plus the address byte ADR and the data control byte BCC.

4 data bytes	LGE=4+1+1=6 bytes
12 data bytes	LGE=12+1+1=14 bytes
Telegrams containing texts	10 ¹ +n bytes

Table 3.25 Length of Telegrams

1) 10 represents the fixed characters, while n is variable (depending on the length of the text).

3.9.7.4 Frequency Converter Address (ADR)

2 different address formats are used.

The address range of the frequency converter is either 1–31 or 1–126.

- Address format 1–31
 - Bit 7=0 (address format 1–31 active).
 - Bit 6 is not used.
 - Bit 5=1: Broadcast, address bits (0–4) are not used.
 - Bit 5=0: No Broadcast.
 - Bit 0–4=frequency converter address 1–31.
- Address format 1–126
 - Bit 7=1 (address format 1–126 active).
 - Bit 0–6=frequency converter address 1–126.
 - Bit 0–6 =0 Broadcast.

The slave returns the address byte unchanged to the master in the response telegram.

3.9.7.5 Data Control Byte (BCC)

The checksum is calculated as an XOR-function. Before the first byte in the telegram is received, the calculated checksum is 0.

3.9.7.6 The Data Field

The structure of data blocks depends on the type of telegram. There are 3 telegram types, and the type applies for both control telegrams (master⇒slave) and response telegrams (slave⇒master).

The 3 types of telegram are:

Process block (PCD)

The PCD is made up of a data block of 4 bytes (2 words) and contains:

- Control word and reference value (from master to slave).
- Status word and present output frequency (from slave to master).



130BA269.10

Illustration 3.47 Process Block

Parameter block

The parameter block is used to transfer parameters between master and slave. The data block is made up of 12 bytes (6 words) and also contains the process block.

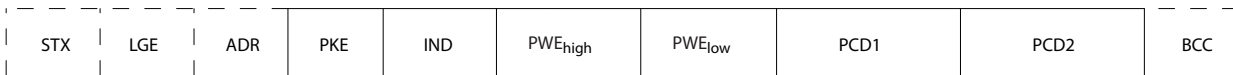

130BA271.10

Illustration 3.48 Parameter Block

Text block

The text block is used to read or write texts via the data block.

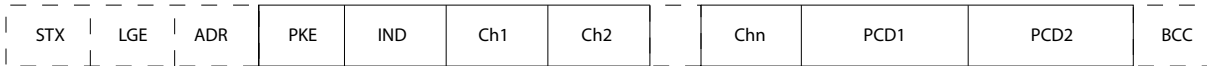

130BA270.10

Illustration 3.49 Text Block

3.9.7.7 The PKE Field

The PKE field contains 2 subfields:

- Parameter command and response AK.
- Parameter number PNU.

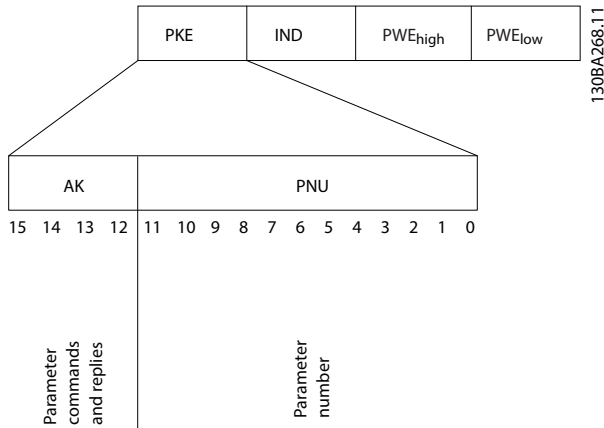

Illustration 3.50 PKE Field

Bits numbers 12–15 transfer parameter commands from master to slave and return processed slave responses to the master.

Bit number				Parameter command
15	14	13	12	
0	0	0	0	No command.
0	0	0	1	Read parameter value.
0	0	1	0	Write parameter value in RAM (word).
0	0	1	1	Write parameter value in RAM (double word).
1	1	0	1	Write parameter value in RAM and EEPROM (double word).
1	1	1	0	Write parameter value in RAM and EEPROM (word).
1	1	1	1	Read/write text.

Table 3.26 Parameter Commands Master⇒Slave

Bit number				Response
15	14	13	12	
0	0	0	0	No response.
0	0	0	1	Parameter value transferred (word).
0	0	1	0	Parameter value transferred (double word).
0	1	1	1	Command cannot be performed.
1	1	1	1	text transferred.

Table 3.27 Response Slave⇒Master

If the command cannot be performed, the slave sends this response:

0111 Command cannot be performed

- and issues a fault report (see Table 3.28) in the parameter value (PWE):

PWE low (hex)	Fault report
0	The parameter number used does not exist.
1	There is no write access to the defined parameter.
2	Data value exceeds the parameter's limits.
3	The sub index used does not exist.
4	The parameter is not the array type.
5	The data type does not match the defined parameter.
11	Data change in the defined parameter is not possible in the frequency converter's present mode. Certain parameters can only be changed when the motor is turned off.
82	There is no bus access to the defined parameter.
83	Data change is not possible because factory set-up is selected

Table 3.28 Parameter Value Fault Report

3.9.7.8 Parameter Number (PNU)

Bits number 0–11 transfer parameter numbers. The function of the relevant parameter is defined in the parameter description in the *programming guide*.

3.9.7.9 Index (IND)

The index is used together with the parameter number to read/write-access parameters with an index, for example, *parameter 15-30 Alarm Log: Error Code*. The index consists of 2 bytes, a low byte and a high byte.

Only the low byte is used as an index.

3.9.7.10 Parameter Value (PWE)

The parameter value block consists of 2 words (4 bytes), and the value depends on the defined command (AK). The master prompts for a parameter value when the PWE block contains no value. To change a parameter value (write), write the new value in the PWE block and send it from the master to the slave.

When a slave responds to a parameter request (read command), the present parameter value in the PWE block is transferred and returned to the master. If a parameter does not contain a numerical value, but several data options, for example *parameter 0-01 Language* where [0] is English, and [4] is Danish, select the data value by entering the value in the PWE block. Serial communication is only capable of reading parameters containing data type 9 (text string).

Parameter 15-40 FC Type to parameter 15-53 Power Card Serial Number contain data type 9.

For example, read the unit size and mains voltage range in *parameter 15-40 FC Type*. When a text string is transferred (read), the length of the telegram is variable, and the texts

are of different lengths. The telegram length is defined in the second byte of the telegram, LGE. When using text transfer, the index character indicates whether it is a read or a write command.

To read a text via the PWE block, set the parameter command (AK) to F hex. The index character high-byte must be 4.

Some parameters contain text that can be written to via the fieldbus. To write a text via the PWE block, set the parameter command (AK) to F hex. The index characters high-byte must be 5.

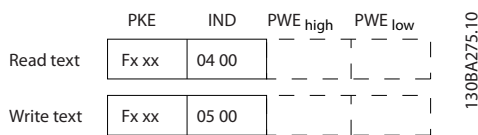

Illustration 3.51 Text via PWE Block

3.9.7.11 Supported Data Types

Unsigned means that there is no operational sign in the telegram.

Data types	Description
3	Integer 16
4	Integer 32
5	Unsigned 8
6	Unsigned 16
7	Unsigned 32
9	Text string
10	Byte string
13	Time difference
33	Reserved
35	Bit sequence

Table 3.29 Supported Data Types

3.9.7.12 Conversion

The various attributes of each parameter are shown in factory setting. Parameter values are transferred as whole numbers only. Conversion factors are therefore used to transfer decimals.

Parameter 4-12 Motor Speed Low Limit [Hz] has a conversion factor of 0.1. To preset the minimum frequency to 10 Hz, transfer the value 100. A conversion factor of 0.1 means that the value transferred is multiplied by 0.1. The value 100 is therefore read as 10.0.

Examples:

- 0 s⇒conversion index 0
- 0.00 s⇒conversion index -2
- 0 ms⇒conversion index -3
- 0.00 ms⇒conversion index -5

3.9.7.13 Process Words (PCD)

The block of process words is divided into 2 blocks of 16 bits, which always occur in the defined sequence.

PCD 1	PCD 2
Control telegram (master⇒slave control word)	Reference value
Control telegram (slave⇒master status word)	Present output frequency

Table 3.30 Process Words (PCD)

3.9.8 FC Protocol Examples

3.9.8.1 Writing a Parameter Value

Change *parameter 4-14 Motor Speed High Limit [Hz]* to 100 Hz.

Write the data in EEPROM.

PKE=E19E hex - Write single word in *parameter 4-14 Motor Speed High Limit [Hz]*.

IND=0000 hex

PWEHIGH=0000 hex

PWELOW=03E8 hex - Data value 1000, corresponding to 100 Hz, see *chapter 3.9.7.12 Conversion*.

The telegram looks like this:

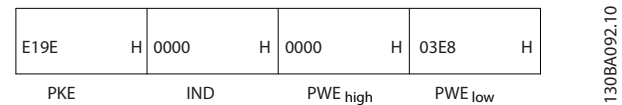

Illustration 3.52 Write Data in EEPROM

NOTICE

Parameter 4-14 Motor Speed High Limit [Hz] is a single word, and the parameter command for write in EEPROM is E. Parameter number 4-14 is 19E in hexadecimal.

The response from the slave to the master is:

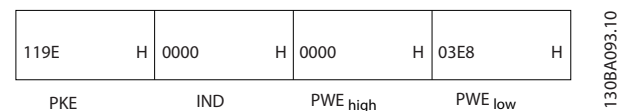

Illustration 3.53 Response from Slave

3.9.8.2 Reading a Parameter Value

Read the value in *parameter 3-41 Ramp 1 Ramp Up Time*.

PKE=1155 hex - Read parameter value in *parameter 3-41 Ramp 1 Ramp Up Time*.

IND=0000 hex

PWEHIGH=0000 hex

PWELOW=0000 hex

3

1155	H	0000	H	0000	H	0000	H
PKE		IND		PWE _{high}		PWE _{low}	

130BA094.10

Illustration 3.54 Parameter Value

If the value in *parameter 3-41 Ramp 1 Ramp Up Time* is 10 s, the response from the slave to the master is

1155	H	0000	H	0000	H	03E8	H
PKE		IND		PWE _{high}		PWE _{low}	

130BA267.10

Illustration 3.55 Response from Slave

3E8 hex corresponds to 1000 decimal. The conversion index for *parameter 3-41 Ramp 1 Ramp Up Time* is -2, that is, 0.01.

Parameter 3-41 Ramp 1 Ramp Up Time is of the type *Unsigned 32*.

3.9.9 Modbus RTU Protocol

3.9.9.1 Assumptions

Danfoss assumes that the installed controller supports the interfaces in this manual, and strictly observes all requirements and limitations stipulated in the controller and frequency converter.

The built-in Modbus RTU (Remote Terminal Unit) is designed to communicate with any controller that supports the interfaces defined in this manual. It is assumed that the user has full knowledge of the capabilities and limitations of the controller.

3.9.9.2 Modbus RTU Overview

Regardless of the type of physical communication networks, the Modbus RTU overview describes the process a controller uses to request access to another device. This process includes how the Modbus RTU responds to requests from another device, and how errors are detected and reported. It also establishes a common format for the layout and contents of message fields.

During communications over a Modbus RTU network, the protocol:

- Determines how each controller learns its device address.
- Recognises a message addressed to it.
- Determines which actions to take.
- Extracts any data or other information contained in the message.

If a reply is required, the controller constructs the reply message and sends it.

Controllers communicate using a master/slave technique in which only the master can initiate transactions (called queries). Slaves respond by supplying the requested data to the master, or by taking the action requested in the query.

The master can address individual slaves, or initiate a broadcast message to all slaves. Slaves return a response to queries that are addressed to them individually. No responses are returned to broadcast queries from the master. The Modbus RTU protocol establishes the format for the master's query by providing:

- The device (or broadcast) address.
- A function code defining the requested action.
- Any data to be sent.
- An error-checking field.

The slave's response message is also constructed using Modbus protocol. It contains fields confirming the action taken, any data to be returned, and an error-checking field. If an error occurs in receipt of the message, or if the slave is unable to perform the requested action, the slave returns an error message. Alternatively, a timeout occurs.

3.9.9.3 Frequency Converter with Modbus RTU

The frequency converter communicates in Modbus RTU format over the built-in RS485 interface. Modbus RTU provides access to the control word and bus reference of the frequency converter.

The control word allows the Modbus master to control several important functions of the frequency converter:

- Start
- Stop of the frequency converter in various ways:
 - Coast stop
 - Quick stop
 - DC brake stop
 - Normal (ramp) stop
- Reset after a fault trip
- Run at various preset speeds
- Run in reverse
- Change the active set-up
- Control the frequency converter's built-in relay

The bus reference is commonly used for speed control. It is also possible to access the parameters, read their values, and, where possible, write values to them. This permits a range of control options, including controlling the setpoint of the frequency converter when its internal PI controller is used.

3.9.9.4 Network Configuration

To enable Modbus RTU on the frequency converter, set the following parameters:

Parameter	Setting
Parameter 8-30 Protocol	Modbus RTU
Parameter 8-31 Address	1–247
Parameter 8-32 Baud Rate	2400–115200
Parameter 8-33 Parity / Stop Bits	Even parity, 1 stop bit (default)

Table 3.31 Modbus RTU Parameters

3.9.10 Modbus RTU Message Framing Structure

3.9.10.1 Frequency Converter with Modbus RTU

The controllers are set up to communicate on the Modbus network using RTU mode, with each byte in a message containing 2 4-bit hexadecimal characters. The format for each byte is shown in Table 3.32.

Start bit	Data byte	Stop/parity	Stop

Table 3.32 Format for Each Byte

Coding system	8-bit binary, hexadecimal 0–9, A–F. 2 hexadecimal characters contained in each 8-bit field of the message.
Bits per byte	1 start bit. 8 data bits, least significant bit sent first; 1 bit for even/odd parity; no bit for no parity. 1 stop bit if parity is used; 2 bits if no parity.
Error check field	Cyclic redundancy check (CRC).

3.9.10.2 Modbus RTU Message Structure

The transmitting device places a Modbus RTU message into a frame with a known beginning and ending point. This allows receiving devices to begin at the start of the message, read the address portion, determine which device is addressed (or all devices, if the message is broadcast), and to recognise when the message is completed. Partial messages are detected and errors set as a result. Characters for transmission must be in hexadecimal 00 to FF format in each field. The frequency converter continuously monitors the network bus, also during silent intervals. When the first field (the address field) is received, each frequency converter or device decodes it to determine which device is being addressed. Modbus RTU messages addressed to zero are broadcast messages. No response is permitted for broadcast messages. A typical message frame is shown in Table 3.33.

Start	Address	Function	Data	CRC check	End
T1-T2-T3-T4	8 bits	8 bits	N x 8 bits	16 bits	T1-T2-T3-T4

Table 3.33 Typical Modbus RTU Message Structure

3.9.10.3 Start/Stop Field

Messages start with a silent period of at least 3.5 character intervals. This is implemented as a multiple of character intervals at the selected network baud rate (shown as Start T1-T2-T3-T4). The first field to be transmitted is the device address. Following the last transmitted character, a similar period of at least 3.5 character intervals marks the end of the message. A new message can begin after this period. The entire message frame must be transmitted as a continuous stream. If a silent period of more than 1.5 character intervals occurs before completion of the frame, the receiving device flushes the incomplete message and assumes that the next byte is the address field of a new message. Similarly, if a new message begins before 3.5 character intervals after a previous message, the receiving device considers it a continuation of the previous message. This causes a timeout (no response from the slave), since the value in the final CRC field is not valid for the combined messages.

3.9.10.4 Address Field

The address field of a message frame contains 8 bits. Valid slave device addresses are in the range of 0–247 decimal. The individual slave devices are assigned addresses in the range of 1–247. (0 is reserved for broadcast mode, which all slaves recognise.) A master addresses a slave by placing the slave address in the address field of the message. When the slave sends its response, it places its own address in this address field to let the master know which slave is responding.

3.9.10.5 Function Field

The function field of a message frame contains 8 bits. Valid codes are in the range of 1–FF. Function fields are used to send messages between master and slave. When a message is sent from a master to a slave device, the function code field tells the slave what action to perform. When the slave responds to the master, it uses the function code field to indicate either a normal (error-free) response, or that an error occurred (called an exception response). For a normal response, the slave simply echoes the original function code. For an exception response, the slave returns a code that is equivalent to the original function code with its most significant bit set to logic 1. In addition, the slave places a unique code into the data field of the response message. This tells the master what error occurred, or the reason for the exception. Also refer to

chapter 3.9.10.10 Function Codes Supported by Modbus RTU and chapter 3.9.10.11 Modbus Exception Codes.

3.9.10.6 Data Field

The data field is constructed using sets of 2 hexadecimal digits, in the range of 00–FF hexadecimal. These are made up of 1 RTU character. The data field of messages sent from a master to a slave device contains extra information, which the slave must use to act as defined by the function code. This can include items such as coil or register addresses, the quantity of items to be handled, and the count of actual data bytes in the field.

3.9.10.7 CRC Check Field

Messages include an error-checking field, operating based on a cyclic redundancy check (CRC) method. The CRC field checks the contents of the entire message. It is applied regardless of any parity check method used for the individual characters of the message. The transmitting device calculates the CRC value and appends the CRC as the last field in the message. The receiving device recalculates a CRC during receipt of the message and compares the calculated value to the actual value received in the CRC field. If the 2 values are unequal, a bus timeout occurs. The error-checking field contains a 16-bit binary value implemented as 2 8-bit bytes. When this is done, the low-order byte of the field is appended first, followed by the high-order byte. The CRC high-order byte is the last byte sent in the message.

3.9.10.8 Coil Register Addressing

In Modbus, all data is organised in coils and holding registers. Coils hold a single bit, whereas holding registers hold a 2-byte word (16 bits). All data addresses in Modbus messages are referenced to zero. The first occurrence of a data item is addressed as item number 0. For example: The coil known as *coil 1* in a programmable controller is addressed as the data address field of a Modbus message. *Coil 127 decimal* is addressed as *coil 007EHEX (126 decimal)*. *Holding register 40001* is addressed as *register 0000* in the data address field of the message. The function code field already specifies a holding register operation. Therefore, the 4XXXX reference is implicit. *Holding register 40108* is addressed as *register 006BHEX (107 decimal)*.

Coil number	Description	Signal direction	
1–16	Frequency converter control word.	Master to slave	
17–32	Frequency converter speed or setpoint reference range 0x0–0xFFFF (-200% ... ~200%).	Master to slave	
33–48	Frequency converter status word (see <i>Table 3.36</i>).	Slave to master	
49–64	Open-loop mode: Frequency converter output frequency. Closed-loop mode: Frequency converter feedback signal.	Slave to master	
65	Parameter write control (master to slave).	Master to slave	
	0 =		Parameter changes are written to the RAM of the frequency converter.
	1 =		Parameter changes are written to the RAM and EEPROM of the frequency converter.
66–65536	Reserved.		

Table 3.34 Coil Descriptions

Coil	0	1
01	Preset reference lsb	
02	Preset reference msb	
03	DC brake	No DC brake
04	Coast stop	No coast stop
05	Quick stop	No quick stop
06	Freeze freq.	No freeze freq.
07	Ramp stop	Start
08	No reset	Reset
09	No jog	Jog
10	Ramp 1	Ramp 2
11	Data not valid	Data valid
12	Relay 1 off	Relay 1 on
13	Relay 2 off	Relay 2 on
14	Set up lsb	
15	Set up msb	
16	No reversing	Reversing

Table 3.35 Frequency Converter Control Word (FC Profile)

Coil	0	1
33	Control not ready	Control ready
34	Frequency converter not ready	Frequency converter ready
35	Coasting stop	Safety closed
36	No alarm	Alarm
37	Not used	Not used
38	Not used	Not used
39	Not used	Not used
40	No warning	Warning
41	Not at reference	At reference
42	Hand mode	Auto mode
43	Out of frequency range	In frequency range
44	Stopped	Running
45	Not used	Not used
46	No voltage warning	Voltage warning
47	Not in current limit	Current limit
48	No thermal warning	Thermal warning

Table 3.36 Frequency Converter Status Word (FC Profile)

Register number	Description
00001–00006	Reserved
00007	Last error code from an FC data object interface
00008	Reserved
00009	Parameter index ¹⁾
00010–00990	000 parameter group (parameters 0-01 through 0-99)
01000–01990	100 parameter group (parameters 1-00 through 1-99)
02000–02990	200 parameter group (parameters 2-00 through 2-99)
03000–03990	300 parameter group (parameters 3-00 through 3-99)
04000–04990	400 parameter group (parameters 4-00 through 4-99)
...	...
49000–49990	4900 parameter group (parameters 49-00 through 49-99)
50000	Input data: Frequency converter control word register (CTW).
50010	Input data: Bus reference register (REF).
...	...
50200	Output data: Frequency converter status word register (STW).
50210	Output data: Frequency converter main actual value register (MAV).

Table 3.37 Holding Registers

1) Used to specify the index number to be used when accessing an indexed parameter.

3.9.10.9 How to Control the Frequency Converter

Codes available for use in the function and data fields of a Modbus RTU message are listed in *chapter 3.9.10.10 Function Codes Supported by Modbus RTU* and *chapter 3.9.10.11 Modbus Exception Codes*.

3.9.10.10 Function Codes Supported by Modbus RTU

Modbus RTU supports use of the function codes (see *Table 3.38*) in the function field of a message.

Function	Function code (hex)
Read coils	1
Read holding registers	3
Write single coil	5
Write single register	6
Write multiple coils	F
Write multiple registers	10
Get communication event counter	B
Report slave ID	11

Table 3.38 Function Codes

Function	Function code	Subfunction code	Subfunction
Diagnostics	8	1	Restart communication
		2	Return diagnostic register
		10	Clear counters and diagnostic register
		11	Return bus message count
		12	Return bus communication error count
		13	Return slave error count
		14	Return slave message count

Table 3.39 Function Codes and Subfunction Codes

3.9.10.11 Modbus Exception Codes

For a full explanation of the structure of an exception code response, refer to *chapter 3.9.10.5 Function Field*.

Code	Name	Meaning
1	Illegal function	The function code received in the query is not an allowable action for the server (or slave). This may be because the function code is only applicable to newer devices, and was not implemented in the unit selected. It could also indicate that the server (or slave) is in the wrong state to process a request of this type, for example because it is not configured and is being asked to return register values.
2	Illegal data address	The data address received in the query is not an allowable address for the server (or slave). More specifically, the combination of reference number and transfer length is invalid. For a controller with 100 registers, a request with offset 96 and length 4 would succeed, a request with offset 96 and length 5 generates exception 02.
3	Illegal data value	A value contained in the query data field is not an allowable value for the server (or slave). This indicates a fault in the structure of the remainder of a complex request, such as that the implied length is incorrect. It specifically does NOT mean that a data item submitted for storage in a register has a value outside the expectation of the application program, since the Modbus protocol is unaware of the significance of any particular value of any particular register.
4	Slave device failure	An unrecoverable error occurred while the server (or slave) was attempting to perform the requested action.

Table 3.40 Modbus Exception Codes

3.9.11 Access to Parameters

3.9.11.1 Parameter Handling

The PNU (parameter number) is translated from the register address contained in the Modbus read or write message. The parameter number is translated to Modbus as (10 x parameter number) decimal. Example: Reading *parameter 3-12 Catch up/slow Down Value* (16 bit): The holding register 3120 holds the parameters value. A value of 1352 (Decimal), means that the parameter is set to 12.52%

Reading *parameter 3-14 Preset Relative Reference* (32 bit): The holding registers 3410 & 3411 holds the parameter's value. A value of 11300 (decimal), means that the parameter is set to 1113.00.

For information on the parameters, size, and converting index, consult the *programming guide*.

3.9.11.2 Storage of Data

The coil 65 decimal determines whether data written to the frequency converter is stored in EEPROM and RAM (coil 65=1) or only in RAM (coil 65=0).

3.9.11.3 IND (Index)

Some parameters in the frequency converter are array parameters, for example *parameter 3-10 Preset Reference*. Since the Modbus does not support arrays in the holding registers, the frequency converter has reserved the holding register 9 as pointer to the array. Before reading or writing an array parameter, set the holding register 9. Setting the holding register to the value of 2 causes all following read/write to array parameters to be to the index 2.

3.9.11.4 Text Blocks

Parameters stored as text strings are accessed in the same way as the other parameters. The maximum text block size is 20 characters. If a read request for a parameter is for more characters than the parameter stores, the response is truncated. If the read request for a parameter is for fewer characters than the parameter stores, the response is space filled.

3.9.11.5 Conversion Factor

Since a parameter value can only be transferred as a whole number, a conversion factor must be used to transfer decimals.

3.9.11.6 Parameter Values

Standard data types

Standard data types are int 16, int 32, uint 8, uint 16, and uint 32. They are stored as 4x registers (40001–4FFFF). The parameters are read using function 03 hex *Read Holding Registers*. Parameters are written using the function 6 hex *Preset Single Register* for 1 register (16 bits), and the function 10 hex *Preset Multiple Registers* for 2 registers (32 bits). Readable sizes range from 1 register (16 bits) up to 10 registers (20 characters).

Non-standard data types

Non-standard data types are text strings and are stored as 4x registers (40001–4FFFF). The parameters are read using function 03 hex *Read Holding Registers* and written using function 10 hex *Preset Multiple Registers*. Readable sizes range from 1 register (2 characters) up to 10 registers (20 characters).

3.9.12 FC Drive Control Profile

3.9.12.1 Control Word According to FC Profile (parameter 8-10 Control Profile=FC profile)

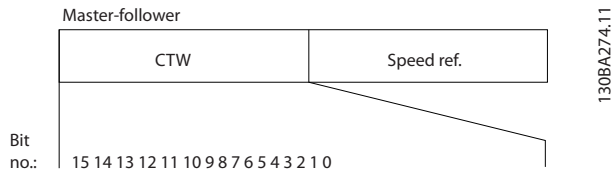

Illustration 3.56 Control Word

Bit	Bit value=0	Bit value=1
00	Reference value	External selection lsb
01	Reference value	External selection msb
02	DC brake	Ramp
03	Coasting	No coasting
04	Quick stop	Ramp
05	Hold output frequency	Use ramp
06	Ramp stop	Start
07	No function	Reset
08	No function	Jog
09	Ramp 1	Ramp 2
10	Data invalid	Data valid
11	No function	Relay 01 active
12	No function	Relay 02 active
13	Parameter set-up	Selection lsb
14	Parameter set-up	Selection msb
15	No function	Reverse

Table 3.41 Control Word Bits

Explanation of the Control Bits

Bits 00/01

Bits 00 and 01 are used to select between the 4 reference values, which are pre-programmed in *parameter 3-10 Preset Reference* according to *Table 3.42*.

Programmed reference value	Parameter	Bit 01	Bit 00
1	<i>Parameter 3-10 Preset Reference</i> [0]	0	0
2	<i>Parameter 3-10 Preset Reference</i> [1]	0	1
3	<i>Parameter 3-10 Preset Reference</i> [2]	1	0
4	<i>Parameter 3-10 Preset Reference</i> [3]	1	1

Table 3.42 Reference Values

NOTICE

Make a selection in *parameter 8-56 Preset Reference Select* to define how bit 00/01 gates with the corresponding function on the digital inputs.

Bit 02, DC brake

Bit 02=0 leads to DC braking and stop. Set braking current and duration in *parameter 2-01 DC Brake Current* and *parameter 2-02 DC Braking Time*.

Bit 02=1 leads to ramping.

Bit 03, Coasting

Bit 03=0: The frequency converter immediately releases the motor (the output transistors are shut off) and it coasts to a standstill.

Bit 03=1: If the other starting conditions are met, the frequency converter starts the motor.

Make a selection in *parameter 8-50 Coasting Select* to define how bit 03 gates with the corresponding function on a digital input.

Bit 04, Quick stop

Bit 04=0: Makes the motor speed ramp down to stop (set in *parameter 3-81 Quick Stop Ramp Time*).

Bit 05, Hold output frequency

Bit 05=0: The present output frequency (in Hz) freezes. Change the frozen output frequency only with the digital inputs (*parameter 5-10 Terminal 18 Digital Input* to *parameter 5-15 Terminal 33 Digital Input*) programmed to *Speed up* and *Slow down*.

NOTICE

If freeze output is active, stop the frequency converter by the following:

- Bit 03 Coasting stop.
- Bit 02 DC braking.
- Digital input (*parameter 5-10 Terminal 18 Digital Input* to *parameter 5-15 Terminal 33 Digital Input*) programmed to *DC braking*, *Coasting stop*, or *Reset and coasting stop*.

Bit 06, Ramp stop/start

Bit 06=0: Causes a stop and makes the motor speed ramp down to stop via the selected ramp down parameter.

Bit 06=1: If the other starting conditions are met, allow the frequency converter to start the motor.

Make a selection in *parameter 8-53 Start Select* to define how bit 06 Ramp stop/start gates with the corresponding function on a digital input.

Bit 07, Reset

Bit 07=0: No reset.

Bit 07=1: Resets a trip. Reset is activated on the signal's leading edge, for example, when changing from logic 0 to logic 1.

Bit 08, Jog

Bit 08=1: *Parameter 3-19 Jog Speed [RPM]* determines the output frequency.

Bit 09, Selection of ramp 1/2

Bit 09=0: Ramp 1 is active (*parameter 3-41 Ramp 1 Ramp Up Time to parameter 3-42 Ramp 1 Ramp Down Time*).

Bit 09=1: Ramp 2 (*parameter 3-51 Ramp 2 Ramp Up Time to parameter 3-52 Ramp 2 Ramp Down Time*) is active.

Bit 10, Data not valid/Data valid

Tells the frequency converter whether to use or ignore the control word.

Bit 10=0: The control word is ignored.

Bit 10=1: The control word is used. This function is relevant because the telegram always contains the control word, regardless of the telegram type. Turn off the control word if it should not be used when updating or reading parameters.

Bit 11, Relay 01

Bit 11=0: Relay not activated.

Bit 11=1: Relay 01 activated if [36] *Control word bit 11* is selected in *parameter 5-40 Function Relay*.

Bit 12, Relay 04

Bit 12=0: Relay 04 is not activated.

Bit 12=1: Relay 04 is activated if [37] *Control word bit 12* is selected in *parameter 5-40 Function Relay*.

Bit 13/14, Selection of set-up

Use bits 13 and 14 to select from the 4 menu set-ups according to *Table 3.43*.

Set-up	Bit 14	Bit 13
1	0	0
2	0	1
3	1	0
4	1	1

Table 3.43 Specification of Menu Set-ups

The function is only possible when [9] *Multi Set-ups* is selected in *parameter 0-10 Active Set-up*.

Make a selection in *parameter 8-55 Set-up Select* to define how bit 13/14 gates with the corresponding function on the digital inputs.

Bit 15 Reverse

Bit 15=0: No reversing.

Bit 15=1: Reversing. In the default setting, reversing is set to digital in *parameter 8-54 Reversing Select*. Bit 15 causes reversing only when [1] *Bus*, [2] *Logic AND* or [3] *Logic OR* is selected.

3.9.12.2 Status Word According to FC Profile (STW) (*parameter 8-10 Control Profile=FC profile*)

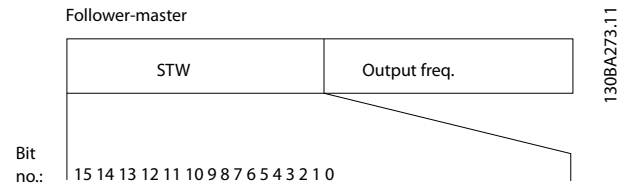

Illustration 3.57 Status Word

Bit	Bit=0	Bit=1
00	Control not ready	Control ready
01	Drive not ready	Drive ready
02	Coasting	Enable
03	No error	Trip
04	No error	Error (no trip)
05	Reserved	-
06	No error	Trip lock
07	No warning	Warning
08	Speed ≠ reference	Speed = reference
09	Local operation	Bus control
10	Out of frequency limit	Frequency limit OK
11	No operation	In operation
12	Drive OK	Stopped, auto start
13	Voltage OK	Voltage exceeded
14	Torque OK	Torque exceeded
15	Timer OK	Timer exceeded

Table 3.44 Status Word Bits

Explanation of the status bits

Bit 00, Control not ready/ready

Bit 00=0: The frequency converter trips.

Bit 00=1: The frequency converter controls are ready but the power component does not necessarily receive any power supply (in case of 24 V external supply to controls).

Bit 01, Drive ready

Bit 01=1: The frequency converter is ready for operation but the coasting command is active via the digital inputs or via serial communication.

Bit 02, Coasting stop

Bit 02=0: The frequency converter releases the motor.

Bit 02=1: The frequency converter starts the motor with a start command.

Bit 03, No error/trip

Bit 03=0: The frequency converter is not in fault mode.

Bit 03=1: The frequency converter trips. To re-establish operation, enter [Reset].

Bit 04, No error/error (no trip)

Bit 04=0: The frequency converter is not in fault mode.
 Bit 04=1: The frequency converter shows an error but does not trip.

Bit 05, Not used

Bit 05 is not used in the status word.

Bit 06, No error/triplock

Bit 06=0: The frequency converter is not in fault mode.
 Bit 06=1: The frequency converter is tripped and locked.

Bit 07, No warning/warning

Bit 07=0: There are no warnings.
 Bit 07=1: A warning has occurred.

Bit 08, Speed≠reference/speed=reference

Bit 08=0: The motor is running, but the present speed is different from the preset speed reference. It might, for example, be the case when the speed ramps up/down during start/stop.
 Bit 08=1: The motor speed matches the preset speed reference.

Bit 09, Local operation/bus control

Bit 09=0: [Stop/Reset] is activated on the control unit or [2] Local control in parameter 3-13 Reference Site is selected. Control via serial communication is not possible.
 Bit 09=1 It is possible to control the frequency converter via the fieldbus/serial communication.

Bit 10, Out of frequency limit

Bit 10=0: The output frequency has reached the value in parameter 4-11 Motor Speed Low Limit [RPM] or parameter 4-13 Motor Speed High Limit [RPM].
 Bit 10=1: The output frequency is within the defined limits.

Bit 11, No operation/in operation

Bit 11=0: The motor is not running.
 Bit 11=1: The frequency converter has a start signal or the output frequency is greater than 0 Hz.

Bit 12, Drive OK/stopped, auto start

Bit 12=0: There is no temporary overtemperature on the inverter.
 Bit 12=1: The inverter stops because of overtemperature, but the unit does not trip and resumes operation once the overtemperature stops.

Bit 13, Voltage OK/limit exceeded

Bit 13=0: There are no voltage warnings.
 Bit 13=1: The DC voltage in the frequency converter's DC link is too low or too high.

Bit 14, Torque OK/limit exceeded

Bit 14=0: The motor current is lower than the torque limit selected in parameter 4-18 Current Limit.
 Bit 14=1: The torque limit in parameter 4-18 Current Limit is exceeded.

Bit 15, Timer OK/limit exceeded

Bit 15=0: The timers for motor thermal protection and thermal protection are not exceeded 100%.
 Bit 15=1: One of the timers exceeds 100%.

If the connection between the InterBus option and the frequency converter is lost, or an internal communication problem has occurred, all bits in the STW are set to 0.

3.9.12.3 Bus Speed Reference Value

Speed reference value is transmitted to the frequency converter in a relative value in %. The value is transmitted in the form of a 16-bit word; in integers (0–32767) the value 16384 (4000 hex) corresponds to 100%. Negative figures are formatted with 2's complement. The actual output frequency (MAV) is scaled in the same way as the bus reference.

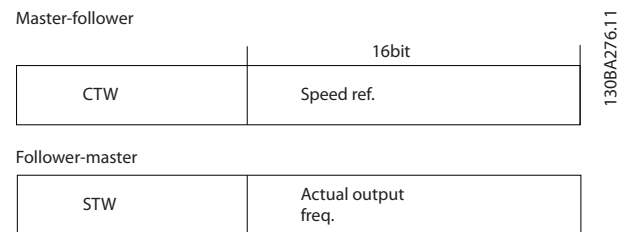

Illustration 3.58 Actual Output Frequency (MAV)

The reference and MAV are scaled as follows:

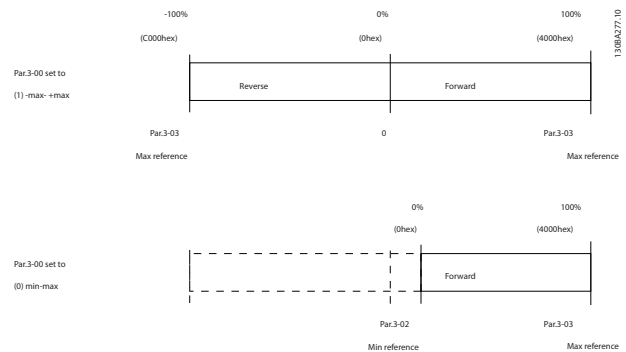

Illustration 3.59 Reference and MAV

3.9.12.4 Control Word according to PROFdrive Profile (CTW)

The control word is used to send commands from a master (for example a PC) to a slave.

3

Bit	Bit=0	Bit=1
00	Off 1	On 1
01	Off 2	On 2
02	Off 3	On 3
03	Coasting	No coasting
04	Quick stop	Ramp
05	Hold frequency output	Use ramp
06	Ramp stop	Start
07	No function	Reset
08	Jog 1 Off	Jog 1 On
09	Jog 2 Off	Jog 2 On
10	Data invalid	Data valid
11	No function	Slow down
12	No function	Catch up
13	Parameter set-up	Selection lsb
14	Parameter set-up	Selection msb
15	No function	Reverse

Table 3.45 Control Word Bits

Explanation of the control bits

Bit 00, OFF 1/ON 1

Normal ramp stops using the ramp times of the actual selected ramp.

Bit 00=0 leads to the stop and activation of the output relay 1 or 2 if the output frequency is 0 Hz, and if [31] Relay 123 has been selected in *parameter 5-40 Function Relay*.

When bit 0=1, the frequency converter is in State 1: *Switching on inhibited*.

Bit 01, Off 2/On 2

Coasting stop

If the output frequency is 0 Hz, and if [31] Relay 123 has been selected in *parameter 5-40 Function Relay*, when bit 01=0, a coasting stop and activation of the output relay 1 or 2 occurs.

Bit 02, Off 3/On 3

Quick stop using the ramp time of *parameter 3-81 Quick Stop Ramp Time*. If the output frequency is 0 Hz and if [31] Relay 123 has been selected in *parameter 5-40 Function Relay*, when bit 02=0, a quick stop and activation of the output relay 1 or 2 occurs.

When bit 02=1, the frequency converter is in State 1: *Switching on inhibited*.

Bit 03, Coasting/No coasting

Coasting stop bit 03=0 leads to a stop.

If the other start conditions are satisfied, when bit 03=1, the frequency converter can start.

NOTICE

The selection in *parameter 8-50 Coasting Select* determines how bit 03 is linked with the corresponding function of the digital inputs.

Bit 04, Quick stop/Ramp

Quick stop using the ramp time of *parameter 3-81 Quick Stop Ramp Time*.

When bit 04=0, a quick stop occurs.

If the other start conditions are fulfilled when bit 04=1, the frequency converter can start.

NOTICE

The selection in *parameter 8-51 Quick Stop Select* determines how bit 04 is linked with the corresponding function of the digital inputs.

Bit 05, Hold frequency output/Use ramp

When bit 05=0, the present output frequency is being maintained even if the reference value is modified.

When bit 05=1, the frequency converter can perform its regulating function again; operation occurs according to the respective reference value.

Bit 06, Ramp stop/Start

Normal ramp stop using the ramp times of the actual ramp as selected. In addition, activation of the output relay 01 or 04 if the output frequency is 0 Hz and if [31] Relay 123 has been selected in *parameter 5-40 Function Relay*.

Bit 06=0 leads to a stop.

If the other start conditions are fulfilled when bit 06=1, the frequency converter can start.

NOTICE

The selection in *parameter 8-53 Start Select* determines how bit 06 is linked with the corresponding function of the digital inputs.

Bit 07, No function/Reset

Reset after switching off.

Acknowledges event in fault buffer.

When bit 07=0, no reset occurs.

When there is a slope change of bit 07 to 1, a reset occurs after switching off.

Bit 08, Jog 1 Off/On

Activation of the pre-programmed speed in *parameter 8-90 Bus Jog 1 Speed*. JOG 1 is only possible if bit 04=0 and bit 00-03=1.

Bit 09, Jog 2 Off/On

Activation of the pre-programmed speed in *parameter 8-91 Bus Jog 2 Speed*. Jog 2 is only possible if bit 04=0 and bit 00-03=1.

Bit 10, Data invalid/valid

Is used to tell the frequency converter whether to use or ignore the control word.

Bit 10=0 causes the control word to be ignored.

Bit 10=1 causes the control word to be used. This function is relevant because the control word is always contained in the telegram, regardless of which type of telegram is used. If it should not be used for updating or reading parameters, it is possible to turn off the control word.

Bit 11, No function/Slow down

Is used to reduce the speed reference value by the amount given in *parameter 3-12 Catch up/slow Down Value*.

When bit 11=0, no modification of the reference value occurs.

When bit 11=1, the reference value is reduced.

Bit 12, No function/catch up

Is used to increase the speed reference value by the amount given in *parameter 3-12 Catch up/slow Down Value*.

When bit 12=0, no modification of the reference value occurs.

When bit 12=1, the reference value is increased.

If both slowing down and accelerating are activated (bit 11 and 12=1), slowing down has priority, that is, the speed reference value is reduced.

Bits 13/14, Set-up selection

Bits 13 and 14 are used to select between the 4 parameter set-ups according to *Table 3.46*.

The function is only possible if [9] *Multi Set-up* has been selected in *parameter 0-10 Active Set-up*. The selection in *parameter 8-55 Set-up Select* determines how bits 13 and 14 are linked with the corresponding function of the digital inputs. Changing set-up while running is only possible if the set-ups have been linked in *parameter 0-12 This Set-up Linked to*.

Set-up	Bit 13	Bit 14
1	0	0
2	1	0
3	0	1
4	1	1

Table 3.46 Set-up Selection

Bit 15, No function/reverse

Bit 15=0 causes no reversing.

Bit 15=1 causes reversing.

NOTICE

In the factory settings, reversing is set to [0] *Digital input in parameter 8-54 Reversing Select*.

NOTICE

Bit 15 causes reversing only when [1] *Bus*, [2] *Logic AND* or [3] *Logic OR* is selected in *parameter 8-54 Reversing Select*.

3.9.12.5 Status Word according to PROFIdrive Profile (STW)

The status word is used to notify a master (for example a PC) about the status of a slave.

Bit	Bit=0	Bit=1
00	Control not ready	Control ready
01	Drive not ready	Drive ready
02	Coasting	Enable
03	No error	Trip
04	Off 2	On 2
05	Off 3	On 3
06	Start possible	Start not possible
07	No warning	Warning
08	Speed≠reference	Speed=reference
09	Local operation	Bus control
10	Out of frequency limit	Frequency limit OK
11	No operation	In operation
12	Drive OK	Stopped, auto start
13	Voltage OK	Voltage exceeded
14	Torque OK	Torque exceeded
15	Timer OK	Timer exceeded

Table 3.47 Status Word Bits

Explanation of the status bits**Bit 00, Control not ready/ready**

When bit 00=0, bit 00, 01, or 02 of the control word is 0 (OFF 1, OFF 2, or OFF 3) – or the frequency converter is switched off (trip).

When bit 00=1, the frequency converter control is ready, but there is not necessarily power supply to the unit present (in the event of 24 V external supply of the control system).

Bit 01, Drive not ready/ready

Same significance as bit 00, however, there is a supply of the power unit. The frequency converter is ready when it receives the necessary start signals.

Bit 02, Coasting/Enable

When bit 02=0, bit 00, 01, or 02 of the control word is 0 (Off 1, Off 2, or Off 3 or coasting) – or the frequency converter is switched off (trip).

When bit 02=1, bit 00, 01, or 02 of the control word is 1; the frequency converter has not tripped.

Bit 03, No error/Trip

When bit 03=0, no error condition of the frequency converter exists.

When bit 03=1, the frequency converter has tripped and requires a reset signal before it can start.

Bit 04, On 2/Off 2

When bit 01 of the control word is 0, then bit 04=0.

When bit 01 of the control word is 1, then bit 04=1.

Bit 05, On 3/Off 3

When bit 02 of the control word is 0, then bit 05=0.

When bit 02 of the control word is 1, then bit 05=1.

Bit 06, Start possible/Start not possible

If [1] *PROFdrive* has been selected in *parameter 8-10 Control Profile*, bit 06 is 1 after a switch-off acknowledgement, after activation of Off2 or Off3, and after switching on the mains voltage, *Start not possible* is reset, with bit 00 of the control word is set to 0, and bits 01, 02, and 10 are set to 1.

Bit 07, No warning/Warning

Bit 07=0 means that there are no warnings.
Bit 07=1 means that a warning has occurred.

Bit 08, Speed≠reference/Speed=reference

When bit 08=0, the current speed of the motor deviates from the set speed reference value. This may occur, for example, when the speed is being changed during start/stop through ramp up/down.

When bit 08=1, the current speed of the motor corresponds to the set speed reference value.

Bit 09, Local operation/Bus control

Bit 09=0 indicates that the frequency converter has been stopped with [Stop] on the LCP, or that [0] *Linked to Hand/Auto* or [2] *Local* has been selected in *parameter 3-13 Reference Site*.

When bit 09=1, the frequency converter can be controlled through the serial interface.

Bit 10, Out of frequency limit/Frequency limit OK

When bit 10=0, the output frequency is outside the limits set in *parameter 4-52 Warning Speed Low* and *parameter 4-53 Warning Speed High*.

When bit 10=1, the output frequency is within the indicated limits.

Bit 11, No operation/Operation

When bit 11=0, the motor does not turn.

When bit 11=1, the frequency converter has a start signal, or the output frequency is higher than 0 Hz.

Bit 12, Drive OK/Stopped, auto start

When bit 12=0, there is no temporary overloading of the inverter.

When bit 12=1, the inverter has stopped due to overloading. However, the frequency converter has not switched off (trip) and starts again after the overloading has ended.

Bit 13, Voltage OK/Voltage exceeded

When bit 13=0, the voltage limits of the frequency converter are not exceeded.

When bit 13=1, the direct voltage in the DC link of the frequency converter is too low or too high.

Bit 14, Torque OK/Torque exceeded

When bit 14=0, the motor torque is below the limit selected in *parameter 4-16 Torque Limit Motor Mode* and *parameter 4-17 Torque Limit Generator Mode*.

When bit 14=1, the limit selected in *parameter 4-16 Torque Limit Motor Mode* or *parameter 4-17 Torque Limit Generator Mode* is exceeded.

Bit 15, Timer OK/Timer exceeded

When bit 15=0, the timers for the thermal motor protection and thermal frequency converter protection have not exceeded 100%.

When bit 15=1, 1 of the timers has exceeded 100%.

3.10 System Design Checklist

Table 3.48 provides a checklist for integrating a frequency converter into a motor control system. The list is intended as a reminder of the general categories and options necessary for specifying the system requirements.

Category	Details	Notes	<input type="checkbox"/>
FC Model			
Power			
	Volts		
	Current		
Physical			
	Dimensions		
	Weight		
Ambient operating conditions			
	Temperature		
	Altitude		
	Humidity		
	Air quality/dust		
	Derating requirements		
Enclosure size			
Input			
Cables			
	Type		
	Length		
Fuses			
	Type		
	Size		
	Rating		
Options			
	Connectors		
	Contacts		
	Filters		
Output			
Cables			
	Type		
	Length		
Fuses			
	Type		
	Size		
	Rating		
Options			
	Filters		
Control			
Wiring			
	Type		
	Length		
	Terminal connections		
Communication			
	Protocol		
	Connection		
	Wiring		
Options			
	Connectors		

3

Category	Details	Notes	<input type="checkbox"/>
	Contacts		
	Filters		
Motor			
	Type		
	Rating		
	Voltage		
	Options		
Special tools and equipment			
	Moving and storage		
	Mounting		
	Connection of mains		

Table 3.48 System Design Checklist

4 Application Examples

4.1 Application Examples

The VLT® Refrigeration Drive FC 103 is designed for refrigeration applications. The wide range of standard and optional features includes optimised SmartStart:

- **Motor alternation**
The motor alternation functionality is suitable for applications (for example fan or pump applications) with 2 motors sharing 1 frequency converter.

NOTICE

Do not use the motor alternation with compressors.

- **Pack control**
Basic pack control is built in as standard with a capacity of up to 3 compressors. Pack control provides speed control of a single compressor in a compressor pack. For control of up to 6 compressors, use the VLT® Extended Relay Card MCB 113.
- **Floating condensing temperature control**
Saves money by monitoring the outdoor temperature and allowing the condensing temperature to be as low as possible, which reduces fan speed and energy consumption.
- **Oil return management**
Oil return management improves reliability and lifetime of the compressor and ensures proper lubrication, by monitoring the variable speed compressor. If it has been running for a certain time, it picks up speed to return oil to the oil reservoir
- **Low and high pressure monitoring**
Saves money by reducing the need for onsite resets. The frequency converter monitors the pressure in the system, and if pressure reaches a level close to the level that engages the shutdown valve, the frequency converter makes a safe shutdown, and restart shortly after.
- **STO**
STO enables Safe Torque Off (coast) when a critical situation occur.
- **Sleep mode**
The sleep mode feature saves energy by stopping the pump when there is no demand.
- **Real time clock.**
- **Smart logic control (SLC)**
SLC comprises programming of a sequence consisting of events and actions. SLC offers a wide range of PLC functions using comparators, logic rules, and timers.

4.2 Selected Application Features

4.2.1 SmartStart

For setting up the frequency converter in the most efficient and logical way, the text and language used in the frequency converter make complete sense to the engineers and installers in the field of refrigeration. To make the installation even more efficient, the built-in Set-up wizard menu guides the user through the set-up of the frequency converter in a clear and structured manner.

The following applications are supported:

- Multi-compressor control.
- Multi-condenser fan, cooling tower/evaporative condensing.
- Single fan and pump.
- Pump system.

The feature is activated at the first power-up, after a factory reset, or from the quick menu. When activating the wizard, the frequency converter asks for the information needed to run the application.

4.2.2 Start/Stop

Terminal 18 = Start/stop parameter 5-10 Terminal 18 Digital Input [8] Start.

Terminal 27 = No operation parameter 5-12 Terminal 27 Digital Input [0] No operation (Default [2] coast inverse).

Parameter 5-10 Terminal 18 Digital Input = [8] Start (default).

Parameter 5-12 Terminal 27 Digital Input = [2] Coast inverse (default).

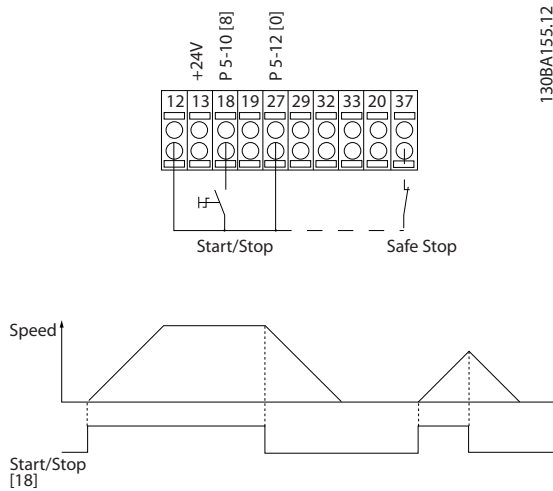

Illustration 4.1 Terminal 37: Available only with Safe Torque Off (STO) Function

4.2.3 Pulse Start/Stop

Terminal 18 = Start/stop parameter 5-10 Terminal 18 Digital Input [9] Latched start.

Terminal 27 = Stop parameter 5-12 Terminal 27 Digital Input [6] Stop inverse.

Parameter 5-10 Terminal 18 Digital Input = [9] Latched start.

Parameter 5-12 Terminal 27 Digital Input = [6] Stop inverse.

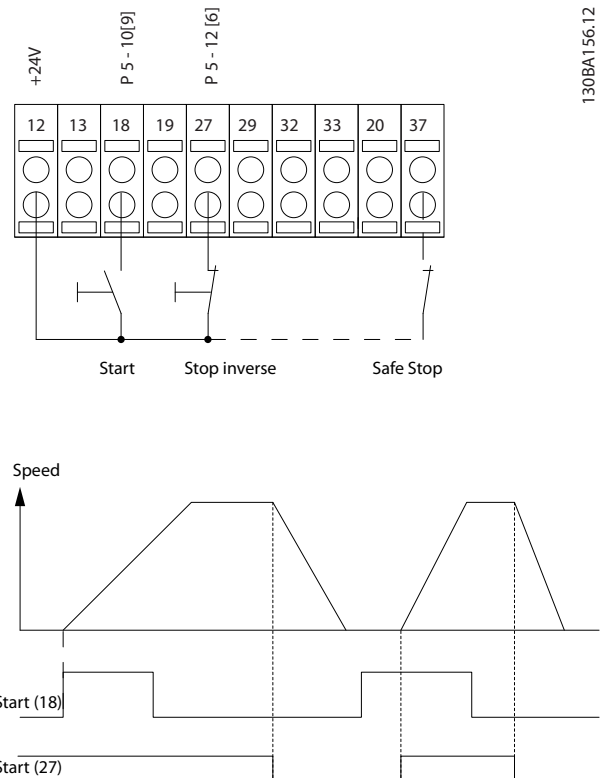

Illustration 4.2 Terminal 37: Available Only with STO Function

4.2.4 Potentiometer Reference

Voltage reference via a potentiometer.

Parameter 3-15 Reference 1 Source [1] = Analog Input 53

Parameter 6-10 Terminal 53 Low Voltage = 0 V

Parameter 6-11 Terminal 53 High Voltage = 10 V

Parameter 6-14 Terminal 53 Low Ref./Feedb. Value = 0 RPM

Parameter 6-15 Terminal 53 High Ref./Feedb. Value = 1.500 RPM

Switch S201 = OFF (U)

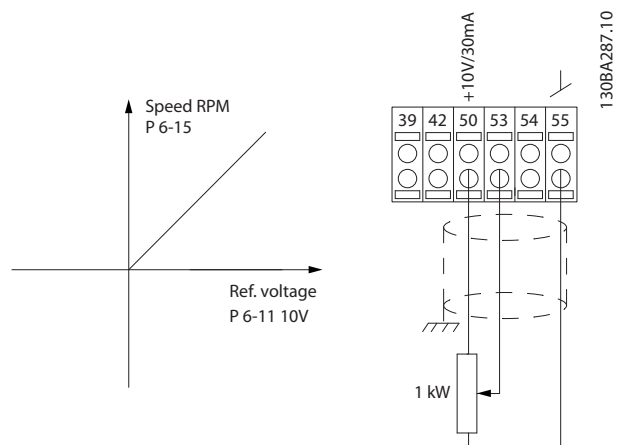

Illustration 4.3 Voltage Reference via a Potentiometer

4.3 Application Set-up Examples

The examples in this section are intended as a quick reference for common applications.

- Parameter settings are the regional default values unless otherwise indicated (selected in *parameter 0-03 Regional Settings*).
- Parameters associated with the terminals and their settings are shown next to the drawings.
- Required switch settings for analog terminals A53 or A54 are also shown.

NOTICE

When using the optional STO feature, a jumper wire may be required between terminal 12 (or 13) and terminal 37 for the frequency converter to operate with factory default programming values.

SLC application example

One sequence 1:

1. Start.
2. Ramp up.
3. Run at reference speed 2 s.
4. Ramp down.
5. Hold shaft until stop.

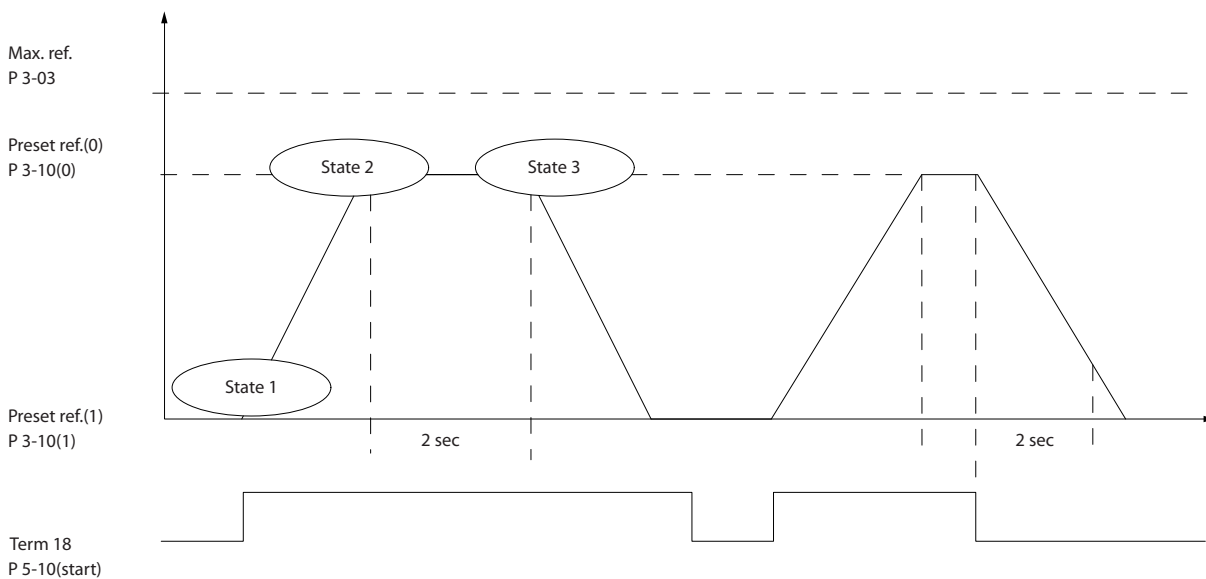

Illustration 4.4 Ramp Up/Ramp Down

Set the ramping times in *parameter 3-41 Ramp 1 Ramp Up Time* and *parameter 3-42 Ramp 1 Ramp Down Time* to the desired times.

$$t_{ramp} = \frac{t_{acc} \times n_{norm} (par. 1 - 25)}{ref [RPM]}$$

Set terminal 27 to [0] No Operation (*parameter 5-12 Terminal 27 Digital Input*)

Set preset reference 0 to first preset speed (*parameter 3-10 Preset Reference [0]*) in percentage of maximum reference speed (*parameter 3-03 Maximum Reference*). Example: 60%

Set preset reference 1 to the second preset speed (*parameter 3-10 Preset Reference [1]*) Example: 0% (zero).

Set the timer 0 for constant running speed in *parameter 13-20 SL Controller Timer [0]*. Example: 2 s

Set Event 1 in *parameter 13-51 SL Controller Event [1]* to [1] True.

Set Event 2 in *parameter 13-51 SL Controller Event [2]* to [4] On Reference.

Set Event 3 in *parameter 13-51 SL Controller Event [3]* to [30] Time Out 0.

Set Event 4 in *parameter 13-51 SL Controller Event [4]* to [0] False.

Set Action 1 in *parameter 13-52 SL Controller Action [1]* to [10] Select preset 0.

Set Action 2 in *parameter 13-52 SL Controller Action [2]* to [29] Start Timer 0.

Set Action 3 in *parameter 13-52 SL Controller Action [3]* to [11] Select preset 1.

Set Action 4 in *parameter 13-52 SL Controller Action [4]* to [1] No Action.

Set the in *parameter 13-00 SL Controller Mode* to ON.

Start/stop command is applied on terminal 18. If the stop signal is applied, the frequency converter ramps down and goes into free mode.

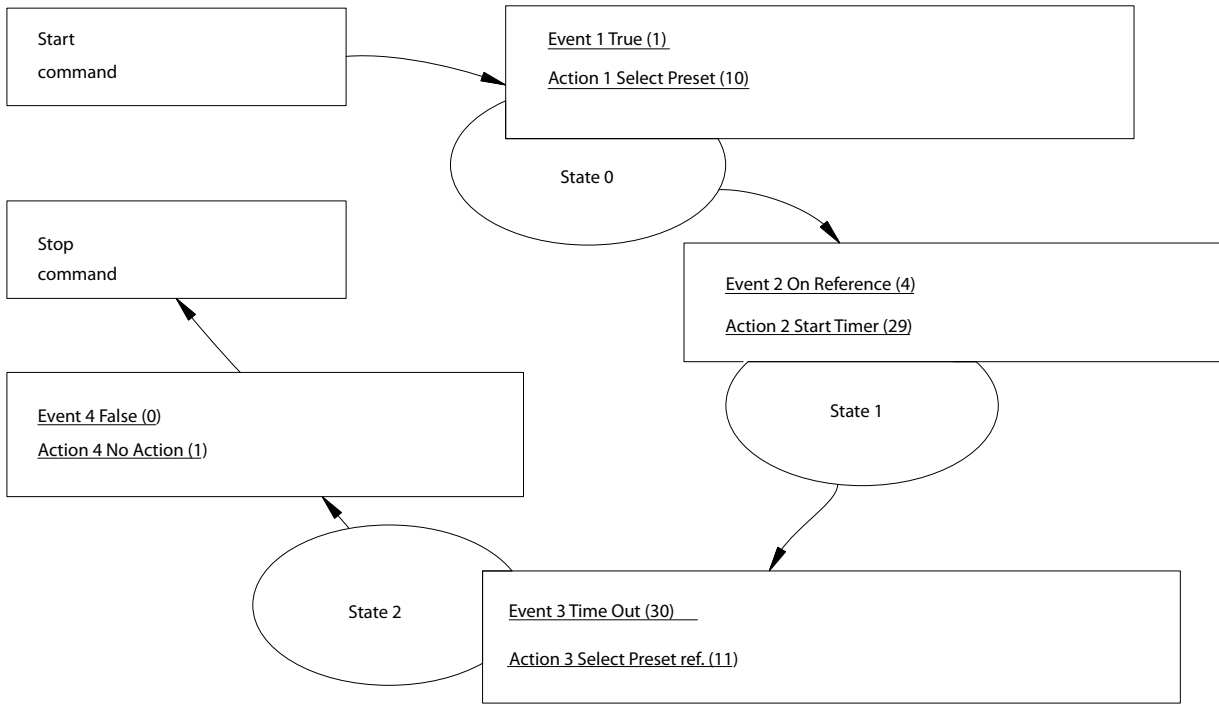

Illustration 4.5 SLC Application Example

4.3.1 Feedback

		Parameters																																													
<table border="1"> <thead> <tr> <th colspan="2">FC</th> </tr> </thead> <tbody> <tr><td>+24 V</td><td>12</td></tr> <tr><td>+24 V</td><td>13</td></tr> <tr><td>D IN</td><td>18</td></tr> <tr><td>D IN</td><td>19</td></tr> <tr><td>COM</td><td>20</td></tr> <tr><td>D IN</td><td>27</td></tr> <tr><td>D IN</td><td>29</td></tr> <tr><td>D IN</td><td>32</td></tr> <tr><td>D IN</td><td>33</td></tr> <tr><td>D IN</td><td>37</td></tr> <tr><td>+10 V</td><td>50</td></tr> <tr><td>A IN</td><td>53</td></tr> <tr><td>A IN</td><td>54</td></tr> <tr><td>COM</td><td>55</td></tr> <tr><td>A OUT</td><td>42</td></tr> <tr><td>COM</td><td>39</td></tr> </tbody> </table>		FC		+24 V	12	+24 V	13	D IN	18	D IN	19	COM	20	D IN	27	D IN	29	D IN	32	D IN	33	D IN	37	+10 V	50	A IN	53	A IN	54	COM	55	A OUT	42	COM	39	<table border="1"> <thead> <tr> <th>Function</th> <th>Setting</th> </tr> </thead> <tbody> <tr> <td>Parameter 6-22 Terminal 54 Low Current</td> <td>4 mA*</td> </tr> <tr> <td>Parameter 6-23 Terminal 54 High Current</td> <td>20 mA*</td> </tr> <tr> <td>Parameter 6-24 Terminal 54 Low Ref./Feedb. Value</td> <td>0*</td> </tr> <tr> <td>Parameter 6-25 Terminal 54 High Ref./Feedb. Value</td> <td>50*</td> </tr> </tbody> </table> <p>* = Default value</p> <p>Notes/comments: D IN 37 is an option.</p>		Function	Setting	Parameter 6-22 Terminal 54 Low Current	4 mA*	Parameter 6-23 Terminal 54 High Current	20 mA*	Parameter 6-24 Terminal 54 Low Ref./Feedb. Value	0*	Parameter 6-25 Terminal 54 High Ref./Feedb. Value	50*
FC																																															
+24 V	12																																														
+24 V	13																																														
D IN	18																																														
D IN	19																																														
COM	20																																														
D IN	27																																														
D IN	29																																														
D IN	32																																														
D IN	33																																														
D IN	37																																														
+10 V	50																																														
A IN	53																																														
A IN	54																																														
COM	55																																														
A OUT	42																																														
COM	39																																														
Function	Setting																																														
Parameter 6-22 Terminal 54 Low Current	4 mA*																																														
Parameter 6-23 Terminal 54 High Current	20 mA*																																														
Parameter 6-24 Terminal 54 Low Ref./Feedb. Value	0*																																														
Parameter 6-25 Terminal 54 High Ref./Feedb. Value	50*																																														

Table 4.1 Analog Current Feedback Transducer

		Parameters																																													
<table border="1"> <thead> <tr> <th colspan="2">FC</th> </tr> </thead> <tbody> <tr><td>+24 V</td><td>12</td></tr> <tr><td>+24 V</td><td>13</td></tr> <tr><td>D IN</td><td>18</td></tr> <tr><td>D IN</td><td>19</td></tr> <tr><td>COM</td><td>20</td></tr> <tr><td>D IN</td><td>27</td></tr> <tr><td>D IN</td><td>29</td></tr> <tr><td>D IN</td><td>32</td></tr> <tr><td>D IN</td><td>33</td></tr> <tr><td>D IN</td><td>37</td></tr> <tr><td>+10 V</td><td>50</td></tr> <tr><td>A IN</td><td>53</td></tr> <tr><td>A IN</td><td>54</td></tr> <tr><td>COM</td><td>55</td></tr> <tr><td>A OUT</td><td>42</td></tr> <tr><td>COM</td><td>39</td></tr> </tbody> </table>		FC		+24 V	12	+24 V	13	D IN	18	D IN	19	COM	20	D IN	27	D IN	29	D IN	32	D IN	33	D IN	37	+10 V	50	A IN	53	A IN	54	COM	55	A OUT	42	COM	39	<table border="1"> <thead> <tr> <th>Function</th> <th>Setting</th> </tr> </thead> <tbody> <tr> <td>Parameter 6-20 Terminal 54 Low Voltage</td> <td>0.07 V*</td> </tr> <tr> <td>Parameter 6-21 Terminal 54 High Voltage</td> <td>10 V*</td> </tr> <tr> <td>Parameter 6-24 Terminal 54 Low Ref./Feedb. Value</td> <td>0*</td> </tr> <tr> <td>Parameter 6-25 Terminal 54 High Ref./Feedb. Value</td> <td>50*</td> </tr> </tbody> </table> <p>* = Default value</p> <p>Notes/comments: D IN 37 is an option.</p>		Function	Setting	Parameter 6-20 Terminal 54 Low Voltage	0.07 V*	Parameter 6-21 Terminal 54 High Voltage	10 V*	Parameter 6-24 Terminal 54 Low Ref./Feedb. Value	0*	Parameter 6-25 Terminal 54 High Ref./Feedb. Value	50*
FC																																															
+24 V	12																																														
+24 V	13																																														
D IN	18																																														
D IN	19																																														
COM	20																																														
D IN	27																																														
D IN	29																																														
D IN	32																																														
D IN	33																																														
D IN	37																																														
+10 V	50																																														
A IN	53																																														
A IN	54																																														
COM	55																																														
A OUT	42																																														
COM	39																																														
Function	Setting																																														
Parameter 6-20 Terminal 54 Low Voltage	0.07 V*																																														
Parameter 6-21 Terminal 54 High Voltage	10 V*																																														
Parameter 6-24 Terminal 54 Low Ref./Feedb. Value	0*																																														
Parameter 6-25 Terminal 54 High Ref./Feedb. Value	50*																																														

Table 4.2 Analog Voltage Feedback Transducer (3-wire)

		Parameters	
FC		Function	Setting
+24 V	12	Parameter 6-20 Terminal 54 Low Voltage	0.07 V*
+24 V	13		
D IN	18	Parameter 6-21 Terminal 54 High Voltage	10 V*
D IN	19		
COM	20	Parameter 6-24 Terminal 54 Low Ref./Feedb. Value	0*
D IN	27		
D IN	29	Parameter 6-25 Terminal 54 High Ref./Feedb. Value	50*
D IN	32		
D IN	33	* = Default value	
D IN	37		
Notes/comments:			
D IN 37 is an option.			

Table 4.3 Analog Voltage Feedback Transducer (4-wire)

		Parameters	
FC		Function	Setting
+24 V	12	Parameter 6-12 Terminal 53 Low Current	4 mA*
+24 V	13		
D IN	18	Parameter 6-13 Terminal 53 High Current	20 mA*
D IN	19		
COM	20	Parameter 6-14 Terminal 53 Low Ref./Feedb. Value	0 Hz
D IN	27		
D IN	29	Parameter 6-15 Terminal 53 High Ref./Feedb. Value	50 Hz
D IN	32		
D IN	33	* = Default value	
D IN	37		
Notes/comments:			
D IN 37 is an option.			

Table 4.5 Analog Speed Reference (Current)

4.3.2 Speed

		Parameters	
FC		Function	Setting
+24 V	12	Parameter 6-10 Terminal 53 Low Voltage	0.07 V*
+24 V	13		
D IN	18	Parameter 6-11 Terminal 53 High Voltage	10 V*
D IN	19		
COM	20	Parameter 6-14 Terminal 53 Low Ref./Feedb. Value	0 Hz
D IN	27		
D IN	29	Parameter 6-15 Terminal 53 High Ref./Feedb. Value	50 Hz
D IN	32		
D IN	33	* = Default value	
D IN	37		
Notes/comments:			
D IN 37 is an option.			

Table 4.4 Analog Speed Reference (Voltage)

		Parameters	
FC		Function	Setting
+24 V	12	Parameter 6-10 Terminal 53 Low Voltage	0.07 V*
+24 V	13		
D IN	18	Parameter 6-11 Terminal 53 High Voltage	10 V*
D IN	19		
COM	20	Parameter 6-14 Terminal 53 Low Ref./Feedb. Value	0 Hz
D IN	27		
D IN	29	Parameter 6-15 Terminal 53 High Ref./Feedb. Value	50 Hz
D IN	32		
D IN	33	* = Default value	
D IN	37		
Notes/comments:			
D IN 37 is an option.			

Table 4.6 Speed Reference (using a Manual Potentiometer)

4.3.3 Run/Stop

		Parameters	
FC		Function	Setting
+24 V	12	Parameter 5-10 Terminal 18 Digital Input	[8] Start*
+24 V	13		
D IN	18	Parameter 5-12 Terminal 27 Digital Input	[7] External interlock
D IN	19		
COM	20	* = Default value	
D IN	27	Notes/comments: D IN 37 is an option.	
D IN	29		
D IN	32		
D IN	33		
D IN	37		
+10 V	50		
A IN	53		
A IN	54		
COM	55		
A OUT	42		
COM	39		

Table 4.7 Run/Stop Command with External Interlock

		Parameters	
FC		Function	Setting
+24 V	12	Parameter 5-10 Terminal 18 Digital Input	[8] Start*
+24 V	13		
D IN	18	Parameter 5-11 Terminal 19 Digital Input	[52] Run Permissive
D IN	19		
COM	20	Parameter 5-12 Terminal 27 Digital Input	[7] External interlock
D IN	27		
D IN	29	Parameter 5-12 Terminal 27 Digital Input	[7] External interlock
D IN	32		
D IN	33	Parameter 5-40 Function Relay	[167] Start command act.
D IN	37		
+10 V	50	* = Default value	
A IN	53	Notes/comments: D IN 37 is an option.	
A IN	54		
COM	55		
A OUT	42		
COM	39		
	01		
	02		
	03		
	04		
	05		
	06		

Table 4.9 Run Permissive

		Parameters	
FC		Function	Setting
+24 V	12	Parameter 5-10 Terminal 18 Digital Input	[8] Start*
+24 V	13		
D IN	18	Parameter 5-12 Terminal 27 Digital Input	[7] External interlock
D IN	19		
COM	20	* = Default value	
D IN	27	Notes/comments: If parameter 5-12 Terminal 27 Digital Input is set to [0] no operation, a jumper wire to terminal 27 is not needed. D IN 37 is an option.	
D IN	29		
D IN	32		
D IN	33		
D IN	37		
+10 V	50		
A IN	53		
A IN	54		
COM	55		
A OUT	42		
COM	39		
	01		
	02		
	03		
	04		
	05		
	06		

Table 4.8 Run/Stop Command without External Interlock

4.3.4 Motor Thermistor

⚠ WARNING

THERMISTOR INSULATION

Risk of personal injury or equipment damage.

- Use only thermistors with reinforced or double insulation to meet PELV insulation requirements.

4

VLT		Parameters	
		Function	Setting
+24 V	12	Parameter 1-90 Motor Thermal Protection	[2] Thermistor trip
+24 V	13		
D IN	18		
D IN	19	Parameter 1-93 T hermistor Source	[1] Analog input 53
COM	20		
D IN	27	* = Default Value	
D IN	29	Notes/comments: If only a warning is required, set parameter 1-90 Motor Thermal Protection to [1] Thermistor warning. D IN 37 is an option.	
D IN	32		
D IN	33		
D IN	37		
D IN	37		
+10 V	50		
A IN	53		
A IN	54		
COM	55		
A OUT	42		
COM	39		

Table 4.10 Motor Thermistor

5 Special Conditions

5.1 Derating

This section provides detailed data regarding the operation of the frequency converter in conditions that require derating. In some conditions, derating is performed manually. In other conditions, the frequency converter performs a degree of automatic derating when necessary. Derating ensures proper performance at critical stages where the alternative can be a trip.

5.2 Manual Derating

5.2.1 When to Consider Derating

Consider derating when any of the following conditions are present:

- Operating above 1000 m (low air pressure).
- Low-speed operation.
- Long motor cables.
- Cables with a large cross-section.
- High ambient temperature.

For more information, refer to *chapter 5.4 Derating for Ambient Temperature*.

5.2.2 Derating for Running at Low Speed

When a motor is connected to a frequency converter, it is necessary to check that the cooling of the motor is adequate.

The level of heating depends on the load on the motor, as well as the operating speed and time.

Constant torque applications (CT mode)

A problem may occur at low RPM values in constant torque applications. In a constant torque application, a motor may overheat at low speeds due to less cooling air from the motor integral fan.

Therefore, if the motor has to run continuously at an RPM value lower than half the rated value, supply the motor with extra air cooling. Alternatively, use a motor designed for this type of operation.

An alternative is to reduce the load level of the motor by selecting a larger motor. However, the design of the frequency converter puts a limit on the motor size.

Variable (quadratic) torque applications (VT)

In VT applications such as centrifugal pumps and fans, where the torque is proportional to the square of the speed, and the power is proportional to the cube of the speed, extra cooling, or derating of the motor is not required.

5.2.3 Derating for Low Air Pressure

The cooling capability of air is decreased at lower air pressure.

Below 1000 m altitude, no derating is necessary. At altitudes above 1000 m, derate the maximum output current (I_{out}) at ambient temperature (T_{AMB}) in accordance with *Illustration 5.1*. At altitudes above 2000 m, contact Danfoss regarding PELV.

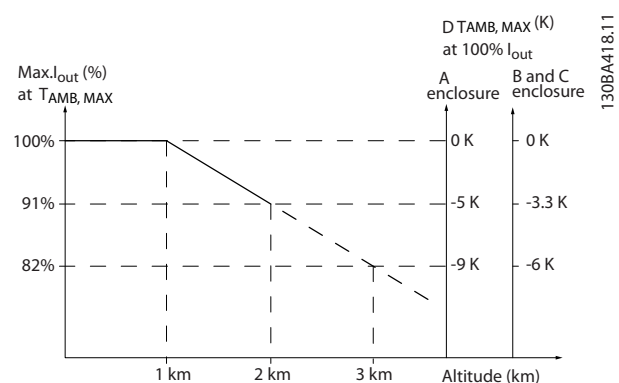

Illustration 5.1 Derating of Output Current versus Altitude at $T_{AMB, MAX}$ for Enclosure Sizes A, B, and C.

An alternative is to lower the ambient temperature at high altitudes to ensure 100% output current at high altitudes. As an example of how to read *Illustration 5.1*, the situation at 2000 m is elaborated for an enclosure size B with $T_{AMB, MAX}=50\text{ }^{\circ}\text{C}$. At a temperature of $45\text{ }^{\circ}\text{C}$ ($T_{AMB, MAX} - 3.3\text{ K}$), 91% of the rated output current is available. At a temperature of $41.7\text{ }^{\circ}\text{C}$, 100% of the rated output current is available.

5.3 Derating for Long Motor Cables or Cables with Larger Cross-section

NOTICE

Applicable for frequency converters up to 90 kW only. The maximum cable length for this frequency converter is 300 m unscreened and 150 m screened cable. The frequency converter has been designed to work using a motor cable with a rated cross-section. If a cable with a larger cross-section is used, reduce the output current by 5% for every step the cross-section is increased.

Increased cable cross-section leads to increased capacity to ground, and thus an increased ground leakage current.

5.4 Derating for Ambient Temperature

The average temperature ($T_{AMB, AVG}$) measured over 24 hours must be at least 5 °C lower than the maximum permitted ambient temperature ($T_{AMB, MAX}$). If the frequency converter operates at high ambient temperatures, then decrease the continuous output current. Derating depends on the switching pattern, which can be set to 60° AVM or SFAVM in *parameter 14-00 Switching Pattern*.

5.4.1 Derating for Ambient Temperature, Enclosure Size A

60° AVM – pulse width modulation

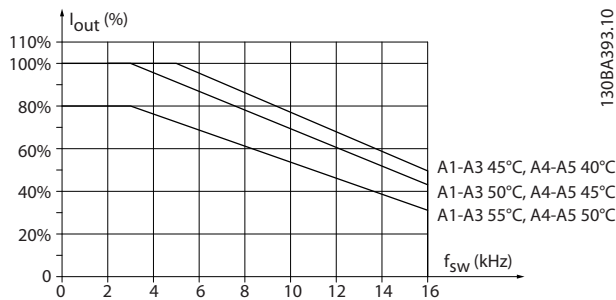

Illustration 5.2 Derating of I_{out} for Different $T_{AMB, MAX}$ for Enclosure Size A, using 60° AVM

SFAVM – stator frequency asynchron vector modulation

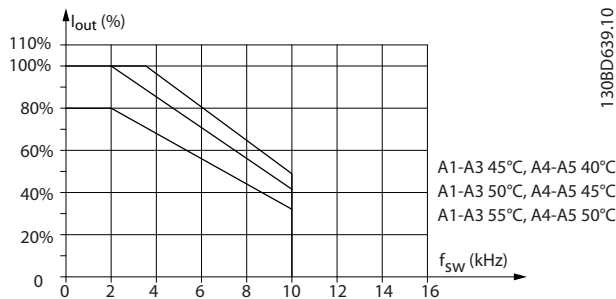

Illustration 5.3 Derating of I_{out} for Different $T_{AMB, MAX}$ for Enclosures Size A, using SFAVM

When using only 10 m motor cable or less in enclosure size A, less derating is necessary. This is because the length of the motor cable has a relatively high impact on the recommended derating.

60° AVM

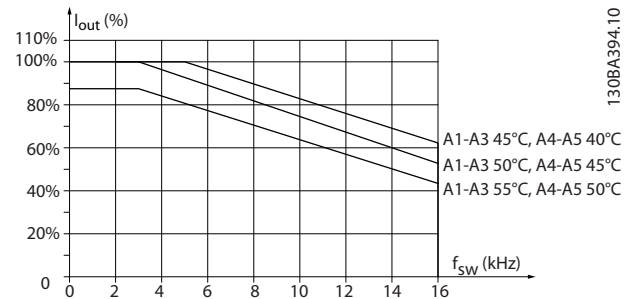

Illustration 5.4 Derating of I_{out} for Different $T_{AMB, MAX}$ for Enclosures Size A, using 60° AVM and Maximum 10 m Motor Cable

SFAVM

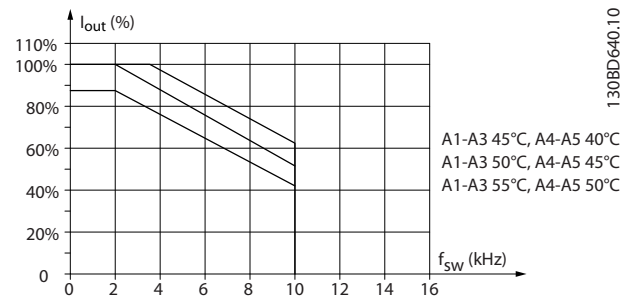

Illustration 5.5 Derating of I_{out} for Different $T_{AMB, MAX}$ for Enclosures Type A, using SFAVM and Maximum 10 m Motor Cable

5.4.2 Derating for Ambient Temperature, Enclosure Size B

Enclosure B, T2, and T4

60° AVM – pulse width modulation

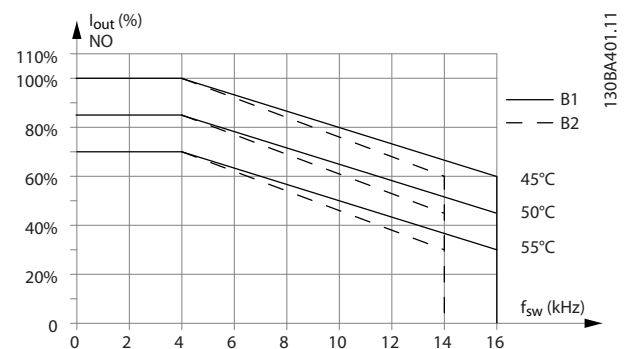

Illustration 5.6 Derating of I_{out} for different $T_{AMB, MAX}$ for Enclosure Sizes B1 and B2, using 60° AVM in Normal Overload Mode (110% Overtorque)

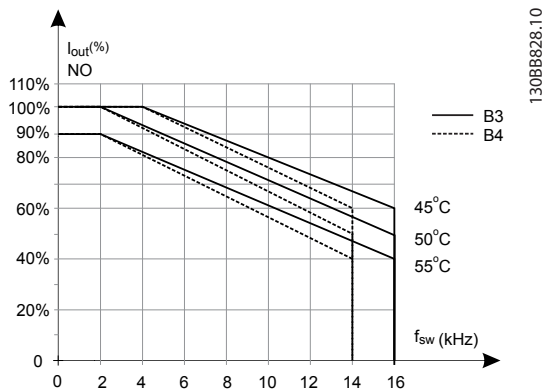

Illustration 5.7 Derating of I_{out} for different $T_{AMB, MAX}$ for Enclosure Sizes B3 and B4, using 60° AVM in Normal Overload Mode (110% Overtorque)

Enclosures B, T6
60° AVM – pulse width modulation

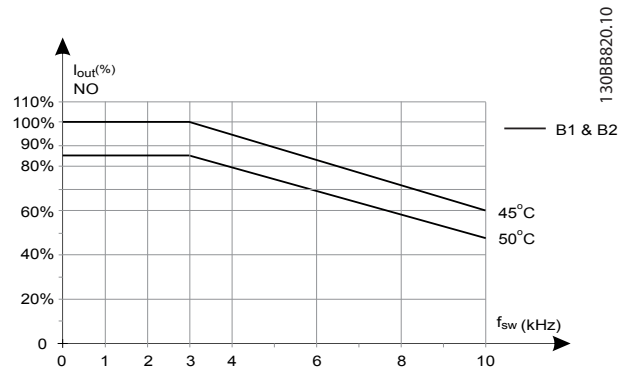

Illustration 5.10 Output Current Derating with Switching Frequency and Ambient Temperature for 600 V Frequency Converters, Enclosure Sizes B, 60 AVM, NO

SFAVM – stator frequency asynchron vector modulation

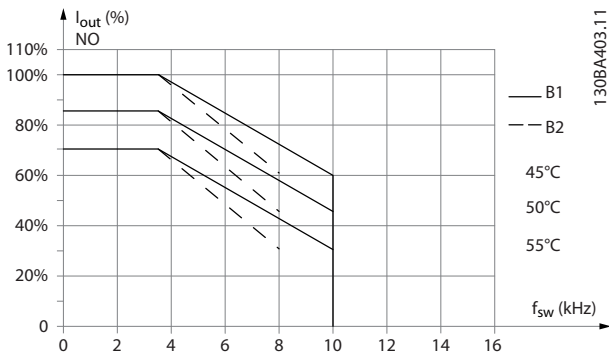

Illustration 5.8 Derating of I_{out} for different $T_{AMB, MAX}$ for Enclosure Sizes B1 and B2, using SFAVM in Normal Overload Mode (110% Overtorque)

SFAVM – stator frequency asynchron vector modulation

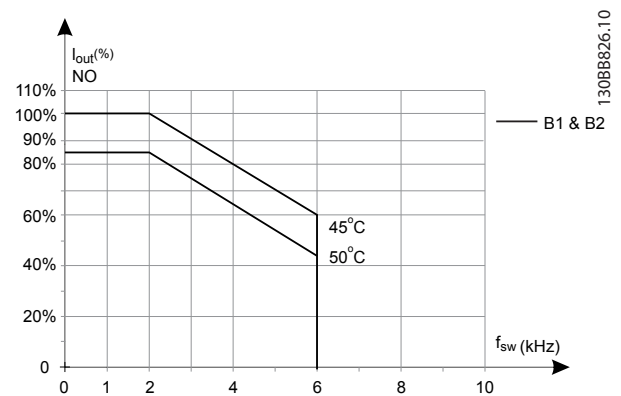

Illustration 5.11 Output Current Derating with Switching Frequency and Ambient Temperature for 600 V Frequency Converters, Enclosure Size B; SFAVM, NO

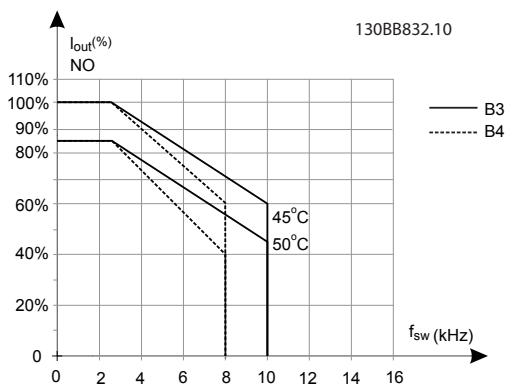

Illustration 5.9 Derating of I_{out} for different $T_{AMB, MAX}$ for Enclosure Sizes B3 and B4, using SFAVM in Normal Overload Mode (110% Overtorque)

**Enclosures B, T7
Enclosures B2 and B4, 525–690 V
60° AVM – pulse width modulation**

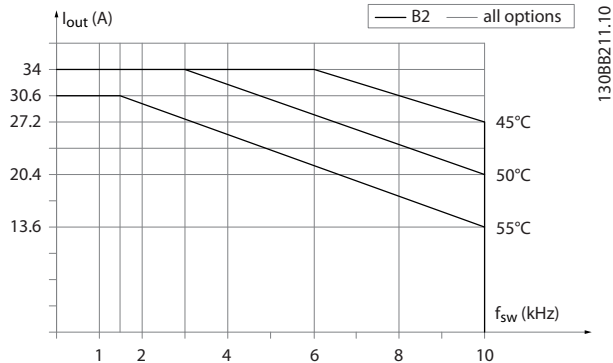

Illustration 5.12 Output Current Derating with Switching Frequency and Ambient Temperature for Enclosure Sizes B2 and B4, 60° AVM.

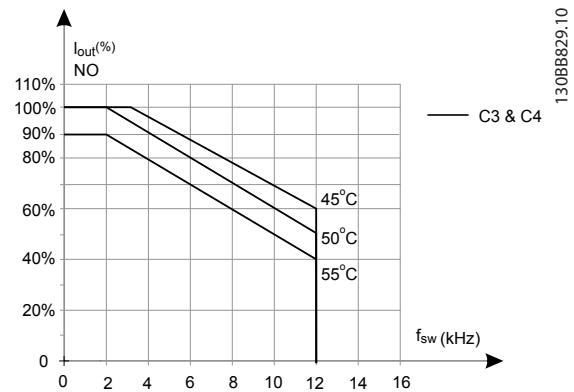

Illustration 5.15 Derating of I_{out} for Different $T_{AMB, MAX}$ for Enclosure Sizes C3 and C4, using 60° AVM in Normal Overload Mode (110% Overtorque)

SFAVM – stator frequency asynchron vector modulation

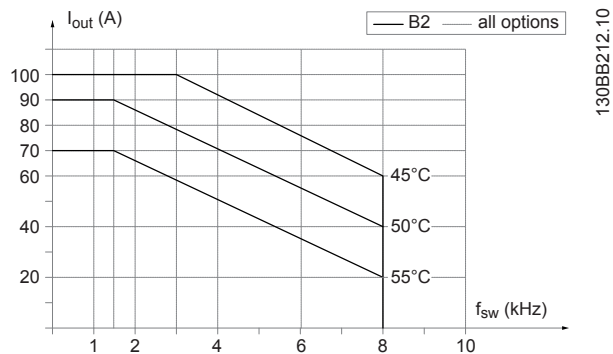

Illustration 5.13 Output Current Derating with Switching Frequency and Ambient Temperature for Enclosure Sizes B2 and B4, SFAVM.

SFAVM – stator frequency asynchron vector modulation



Illustration 5.16 Derating of I_{out} for Different $T_{AMB, MAX}$ for Enclosure Sizes C1 and C2, using SFAVM in Normal Overload Mode (110% Overtorque)

5.4.3 Derating for Ambient Temperature, Enclosure Size C

**Enclosures C, T2, and T4
60° AVM – pulse width modulation**

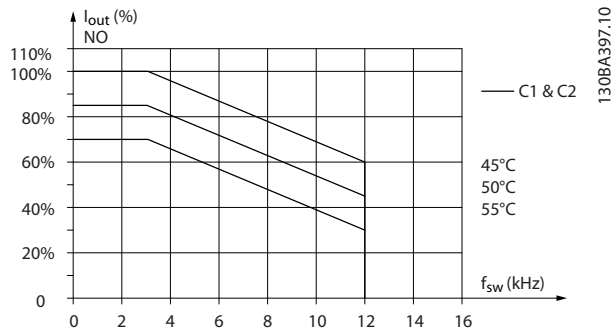

Illustration 5.14 Derating of I_{out} for Different $T_{AMB, MAX}$ for Enclosure Sizes C1 and C2, using 60° AVM in Normal Overload Mode (110% Overtorque)

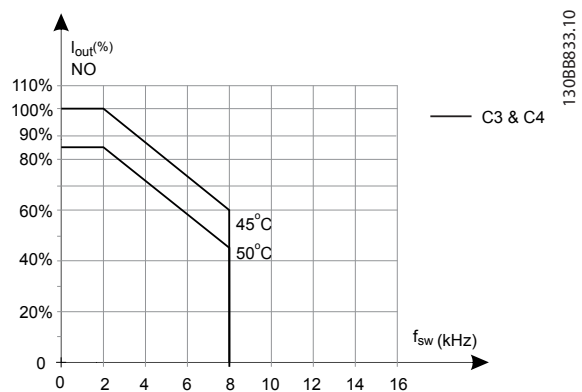

Illustration 5.17 Derating of I_{out} for Different $T_{AMB, MAX}$ for Enclosure Sizes C3 and C4, using SFAVM in Normal Overload Mode (110% Overtorque)

Enclosure Sizes C, T6
60° AVM – pulse width modulation

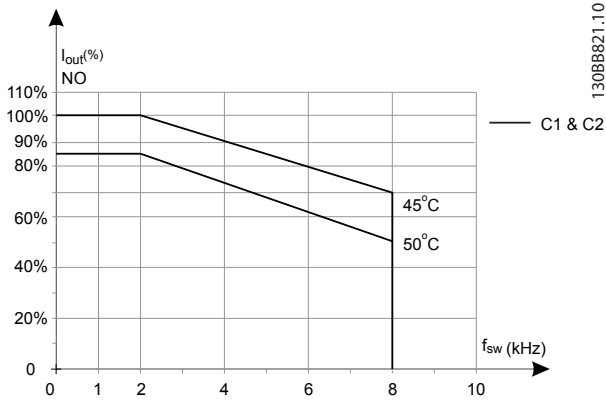

Illustration 5.18 Output Current Derating with Switching Frequency and Ambient Temperature for 600 V Frequency Converters, Enclosure Sizes C, 60° AVM, NO

SFAVM – stator frequency asynchron vector modulation

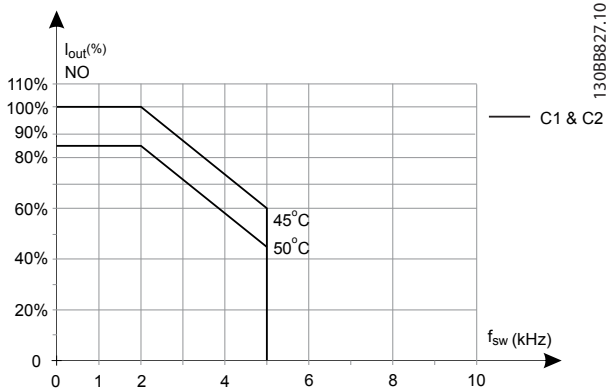

Illustration 5.19 Output Current Derating with Switching Frequency and Ambient Temperature for 600 V Frequency Converters, Enclosure Sizes C; SFAVM, NO

Enclosure Size C, T7
60° AVM – pulse width modulation

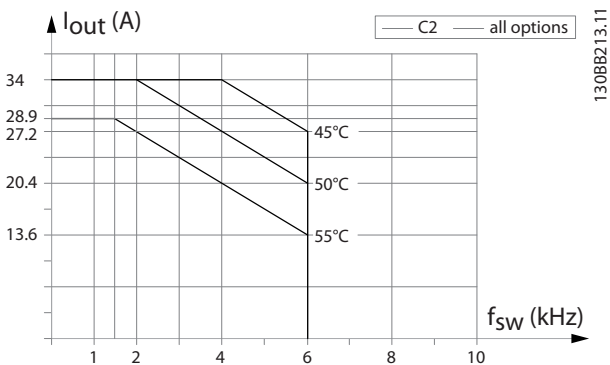

Illustration 5.20 Output Current Derating with Switching Frequency and Ambient Temperature for Enclosure Size C2, 60° AVM.

SFAVM – stator frequency asynchron vector modulation

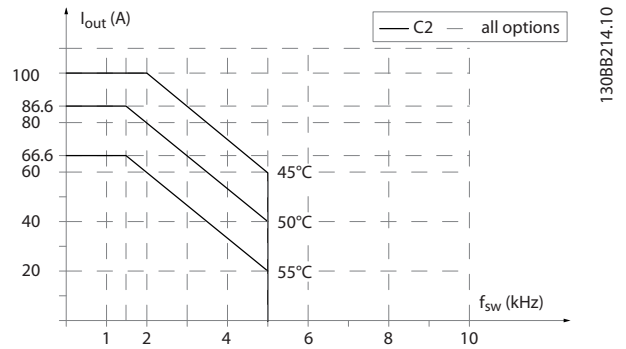

Illustration 5.21 Output Current Derating with Switching Frequency and Ambient Temperature for Enclosure Size C2, SFAVM.

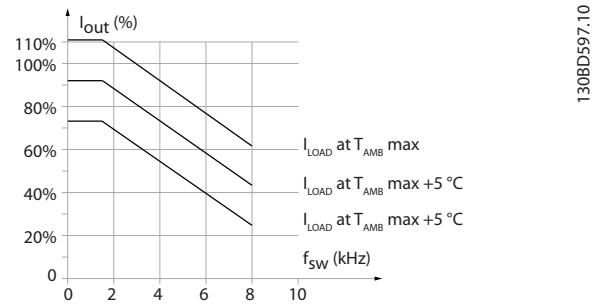
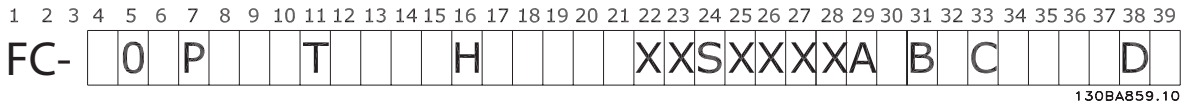

Illustration 5.22 Output Current Derating with Switching Frequency and Ambient Temperature for Enclosure Size C3

6 Type Code and Selection

6.1 Ordering

6.1.1 Introduction



130BA859.10

Illustration 6.1 Type Code

6

Configure the right frequency converter for the right application from the internet-based Drive Configurator and generate the type code string. The Drive Configurator generates an 8-digit ordering number for delivery to the local sales office.

The Drive Configurator can also establish a project list with several products and send it to a Danfoss sales representative.

Access the Drive Configurator on the global internet site: www.danfoss.com/drives.

6.1.2 Type Code

An example of the type code is:
FC-103-P18KT4E21H1XGCSXXSXXXAZBKXXXXX

Table 6.1 and Table 6.2 describe the meaning of the characters in the string. In the example above, an AK-LonWorks option and a General Purpose I/O option is included in the frequency converter.

Description	Position	Possible options ¹⁾
Product group & VLT Series	1–6	FC 103
Power rating	8–10	1.1–90 kW (P1K1-P90K)
Number of phases	11	3 phases (T)
Mains voltage	11–12	T 2: 200–240 V AC T 4: 380–480 V AC
Enclosure	13–15	E20: IP20 E21: IP 21/NEMA 1 E55: IP 55/NEMA 12 E66: IP66 P21: IP21/NEMA 1 w/ backplate P55: IP55/NEMA 12 w/ backplate Z55: A4 Enclosure IP55 Z66: A4 Enclosure IP66

Description	Position	Possible options ¹⁾
RFI filter	16–17	H1: RFI filter class A1/B H2: RFI filter class A2 Hx: No RFI filter
Display	19	G: Graphical local control panel (GLCP) X: No local control panel
Coating PCB	20	X: No coated PCB C: Coated PCB
Mains option	21	X: No Mains disconnect switch 1: With Mains disconnect switch (IP55 only)
Adaptation	22	Reserved
Adaptation	23	Reserved
Software release	24–27	Actual software
Software language	28	

Table 6.1 Ordering Type Code

1) Some of the available options depend on the enclosure size.

Description	Position	Possible options
A options	29–30	AX: No options AZ: VLT® AK-LonWorks MCA 107 A0: VLT® PROFIBUS DP MCA 101 AL: VLT® PROFINET MCA 120
B options	31–32	BX: No option BK: General Purpose I/O option MCB 101 BP: VLT® Relay option MCB 105 BO: VLT® Analog I/O option MCB 109
C0 options MCO	33–34	CX: No options
C1 options	35	X: No options R: VLT® Extended Relay Card MCB 113
C option software	36–37	XX: Standard software

Description	Position	Possible options
D options	38–39	DX: No option D0: VLT® 24 V DC Supply option MCB 107

Table 6.2 Ordering Type Code, Options

6.2 Options, Accessories, and Spare Parts

6.2.1 Ordering Numbers: Options and Accessories

NOTICE

Options can be ordered as factory built-in options, see ordering information.

Type	Description	Ordering number
Miscellaneous hardware I		
DC link connector	Terminal block for DC link connection on A2/A3	130B1064
IP 21/4X top/TYPE 1 kit	IP21/NEMA1 top + bottom A2	130B1122
IP 21/4X top/TYPE 1 kit	IP21/NEMA1 top + bottom A3	130B1123
IP 21/4X top/TYPE 1 kit	IP21/NEMA1 top + bottom B3	130B1187
IP 21/4X top/TYPE 1 kit	IP21/NEMA1 top + bottom B4	130B1189
IP 21/4X top/TYPE 1 kit	IP21/NEMA1 top + bottom C3	130B1191
IP 21/4X top/TYPE 1 kit	IP21/NEMA1 top + bottom C4	130B1193
IP21/4X top	IP21 top cover A2	130B1132
IP21/4X top	IP21 top cover A3	130B1133
IP 21/4X top	IP21 top cover B3	130B1188
IP 21/4X top	IP21 top cover B4	130B1190
IP 21/4X top	IP21 top cover C3	130B1192
IP 21/4X top	IP21 top cover C4	130B1194
Panel Through Mount Kit	Enclosure size A5	130B1028
Panel Through Mount Kit	Enclosure size B1	130B1046

Type	Description	Ordering number
Miscellaneous hardware I		
Panel Through Mount Kit	Enclosure size B2	130B1047
Panel Through Mount Kit	Enclosure size C1	130B1048
Panel Through Mount Kit	Enclosure size C2	130B1049
Terminal blocks	Screw terminal blocks for replacing spring loaded terminals 1 pc 10-pin, 1 pc 6-pin, and 1 pc 3-pin connectors	130B1116
Back plate	A5 IP55/NEMA 12	130B1098
Back plate	B1 IP21/IP55/NEMA 12	130B3383
Back plate	B2 IP21/IP55/NEMA 12	130B3397
Back plate	C1 IP21/IP55/NEMA 12	130B3910
Back plate	C2 IP21/IP55/NEMA 12	130B3911
Back plate	A5 IP66	130B3242
Back plate	B1 IP66	130B3434
Back plate	B2 IP66	130B3465
Back plate	C1 IP66	130B3468
Back plate	C2 IP66	130B3491
LCPs and kits		
LCP 102	Graphical local control panel (GLCP)	130B1107
LCP cable	Separate LCP cable, 3 m	175Z0929
LCP kit	LCP mounting kit including graphical LCP, fasteners, 3 m cable, and gasket	130B1113
LCP kit	LCP mounting kit including numerical LCP, fasteners, and gasket	130B1114
LCP kit	LCP mounting kit for all LCPs including fasteners, 3 m cable, and gasket	130B1117
LCP kit	Front mounting kit, IP55/IP66 enclosures, fasteners, 8 m cable, and gasket	130B1129
LCP kit	LCP mounting kit for all LCPs including fasteners and gasket - without cable	130B1170

Table 6.3 Options and Accessories

Type	Description	Comments
Options for Slot A		Ordering number coated
MCA 107	AK-LonWorks	130B1108
Options for Slot B		
MCB 101	VLT® General Purpose I/O Module MCB 101	130B1212
MCB 105	VLT® Relay Card MCB 105	130B1210
MCB 109	VLT® Analog I/O MCB 109 option and battery back-up for real time clock	130B1243
Option for Slot C		
MCB 113	VLT® Extended Relay Card MCB 113	130B1264
Option for Slot D		
MCB 107	24 V DC Back-up	130B1208

Table 6.4 Ordering Numbers for A, B, C, and D Options

For information on fieldbus and application option compatibility with older software versions, contact the Danfoss supplier.

6

Type	Description	Ordering number	Comments
Spare parts			
Control board FC	With STO function	130B1150	
Control board FC	Without STO function	130B1151	
Fan A2	Fan, enclosure size A2	130B1009	
Fan A3	Fan, enclosure size A3	130B1010	
Fan A5	Fan, enclosure size A5	130B1017	
Fan B1	Fan external, enclosure size B1	130B3407	
Fan B2	Fan external, enclosure size B2	130B3406	
Fan B3	Fan external, enclosure size B3	130B3563	
Fan B4	Fan external, 18.5/22 kW	130B3699	
Fan B4	Fan external 22/30 kW	130B3701	
Fan C1	Fan external, enclosure size C1	130B3865	
Fan C2	Fan external, enclosure size C2	130B3867	
Fan C3	Fan external, enclosure size C3	130B4292	
Fan C4	Fan external, enclosure size C4	130B4294	
Miscellaneous hardware II			
Accessory bag A2	Accessory bag, enclosure size A2	130B1022	
Accessory bag A3	Accessory bag, enclosure size A3	130B1022	
Accessory bag A5	Accessory bag, enclosure size A5	130B1023	
Accessory bag B1	Accessory bag, enclosure size B1	130B2060	
Accessory bag B2	Accessory bag, enclosure size B2	130B2061	
Accessory bag B3	Accessory bag, enclosure size B3	130B0980	
Accessory bag B4	Accessory bag, enclosure size B4	130B1300	Small
Accessory bag B4	Accessory bag, enclosure size B4	130B1301	Big
Accessory bag C1	Accessory bag, enclosure size C1	130B0046	
Accessory bag C2	Accessory bag, enclosure size C2	130B0047	
Accessory bag C3	Accessory bag, enclosure size C3	130B0981	
Accessory bag C4	Accessory bag, enclosure size C4	130B0982	Small
Accessory bag C4	Accessory bag, enclosure size C4	130B0983	Big

Table 6.5 Ordering Numbers for Spare Parts

6.2.2 Ordering Numbers: Harmonic Filters

Harmonic filters are used to reduce mains harmonics.

For ordering numbers, see the *VLT® Advanced Harmonic Filter AHF 005/AHF 010 Design Guide*.

NOTICE

Support of AHF and sine-wave filters requires software version 1.1x or above. dU/dt filters are supported and can be used on any software version.

6.2.3 Ordering Numbers: Sine-wave Filter Modules, 200–480 V AC

Frequency converter size			Minimum switching frequency [kHz]	Maximum output frequency [Hz]	Part number IP20	Part number IP00	Rated filter current at 50 Hz [A]
200–240 V	380–440 V	440–480 V					
	P1K1	P1K1	5	120	130B2441	130B2406	4.5
	P1K5	P1K5	5	120	130B2441	130B2406	4.5
	P2K2	P2K2	5	120	130B2443	130B2408	8
P1K1	P3K0	P3K0	5	120	130B2443	130B2408	8
P1K5			5	120	130B2443	130B2408	8
	P4K0	P4K0	5	120	130B2444	130B2409	10
P2K2	P5K5	P5K5	5	120	130B2446	130B2411	17
P3K0	P7K5	P7K5	5	120	130B2446	130B2411	17
P4K0			5	120	130B2446	130B2411	17
P5K5	P11K	P11K	4	60	130B2447	130B2412	24
P7K5	P15K	P15K	4	60	130B2448	130B2413	38
	P18K	P18K	4	60	130B2448	130B2413	38
P11K	P22K	P22K	4	60	130B2307	130B2281	48
P15K	P30K	P30K	3	60	130B2308	130B2282	62
P18K	P37K	P37K	3	60	130B2309	130B2283	75
P22K	P45K	P55K	3	60	130B2310	130B2284	115
P30K	P55K	P75K	3	60	130B2310	130B2284	115
P37K	P75K	P90K	3	60	130B2311	130B2285	180
P45K	P90K		3	60	130B2311	130B2285	180

Table 6.6 Mains Supply 3x200–480 V

NOTICE

When using sine-wave filters, the switching frequency should comply with filter specifications in parameter 14-01 *Switching Frequency*.

NOTICE

See also the *Output Filters Design Guide*.

6.2.4 Ordering Numbers: Sine-wave Filter Modules, 525-600/690 V AC

Frequency converter size		Minimum switching frequency [kHz]	Maximum output frequency [Hz]	Part number IP20	Part number IP00	Rated filter current at 50 Hz [A]
525-600 V	690 V					
P1K1		2	60	130B2341	130B2321	13
P1K5		2	60	130B2341	130B2321	13
P2k2		2	60	130B2341	130B2321	13
P3K0		2	60	130B2341	130B2321	13
P4K0		2	60	130B2341	130B2321	13
P5K5		2	60	130B2341	130B2321	13
P7K5		2	60	130B2341	130B2321	13
	P11K	2	60	130B2342	130B2322	28
P11K	P15K	2	60	130B2342	130B2322	28
P15K	P18K	2	60	130B2342	130B2322	28
P18K	P22K	2	60	130B2342	130B2322	28
P22K	P30K	2	60	130B2343	130B2323	45
P30K	P37K	2	60	130B2343	130B2323	45
P37K	P45K	2	60	130B2344	130B2324	76
P45K	P55K	2	60	130B2344	130B2324	76
P55K	P75K	2	60	130B2345	130B2325	115
P75K	P90K	2	60	130B2345	130B2325	115
P90K		2	60	130B2346	130B2326	165

Table 6.7 Mains Supply 3x525-690 V

NOTICE

When using sine-wave filters, the switching frequency should comply with filter specifications in parameter 14-01 Switching Frequency.

NOTICE

See also the *Output Filters Design Guide*.

6.2.5 Harmonic Filters

Harmonic filters are used to reduce mains harmonics.

- AHF 010: 10% current distortion.
- AHF 005: 5% current distortion.

Cooling and ventilation

IP20: Cooled by natural convection or with built-in fans.

IP00: Extra forced cooling is required. Secure sufficient airflow through the filter during installation to prevent overheating of the filter. Airflow of minimum 2 m/s is required through the filter.

Power and current ratings ¹⁾		Typical motor [kW]	Filter current rating		Ordering number AHF 005		Ordering number AHF 010	
[kW]	[A]		50 Hz		IP00	IP20	IP00	IP20
1.1–4.0	1.2–9	3	10	130B1392	130B1229	130B1262	130B1027	
5.5–7.5	14.4	7.5	14	130B1393	130B1231	130B1263	130B1058	
11.0	22	11	22	130B1394	130B1232	130B1268	130B1059	
15.0	29	15	29	130B1395	130B1233	130B1270	130B1089	
18.0	34	18.5	34	130B1396	130B1238	130B1273	130B1094	
22.0	40	22	40	130B1397	130B1239	130B1274	130B1111	
30.0	55	30	55	130B1398	130B1240	130B1275	130B1176	
37.0	66	37	66	130B1399	130B1241	130B1281	130B1180	
45.0	82	45	82	130B1442	130B1247	130B1291	130B1201	
55.0	96	55	96	130B1443	130B1248	130B1292	130B1204	
75.0	133	75	133	130B1444	130B1249	130B1293	130B1207	
90.0	171	90	171	130B1445	130B1250	130B1294	130B1213	

Table 6.8 Harmonic Filters for 380–415 V, 50 Hz

Power and current ratings ¹⁾		Typical motor [kW]	Filter current rating		Ordering number AHF 005		Ordering number AHF 010	
[kW]	[A]		60 Hz		IP00	IP20	IP00	IP20
1.1–4.0	1.2–9	3	10	130B3095	130B2857	130B2874	130B2262	
5.5–7.5	14.4	7.5	14	130B3096	130B2858	130B2875	130B2265	
11.0	22	11	22	130B3097	130B2859	130B2876	130B2268	
15.0	29	15	29	130B3098	130B2860	130B2877	130B2294	
18.0	34	18.5	34	130B3099	130B2861	130B3000	130B2297	
22.0	40	22	40	130B3124	130B2862	130B3083	130B2303	
30.0	55	30	55	130B3125	130B2863	130B3084	130B2445	
37.0	66	37	66	130B3026	130B2864	130B3085	130B2459	
45.0	82	45	82	130B3127	130B2865	130B3086	130B2488	
55.0	96	55	96	130B3128	130B2866	130B3087	130B2489	
75.0	133	75	133	130B3129	130B2867	130B3088	130B2498	
90.0	171	90	171	130B3130	130B2868	130B3089	130B2499	

Table 6.9 Harmonic Filters for 380–415 V, 60 Hz

Power and current rating ¹⁾		Typical motor	Filter current rating		Ordering number AHF 005		Ordering number AHF 010	
			60 Hz		IP00	IP20	IP00	IP20
[kW]	[A]	[kW]	[A]	[A]				
1.1–4.0	1–7.4	3	10		130B1787	130B1752	130B1770	130B1482
5.5–7.5	9.9–13	7.5	14		130B1788	130B1753	130B1771	130B1483
11.0	19	11	19		130B1789	130B1754	130B1772	130B1484
15.0	25	15	25		130B1790	130B1755	130B1773	130B1485
18.0	31	18.5	31		130B1791	130B1756	130B1774	130B1486
22.0	36	22	36		130B1792	130B1757	130B1775	130B1487
30.0	47	30	48		130B1793	130B1758	130B1776	130B1488
37.0	59	37	60		130B1794	130B1759	130B1777	130B1491
45.0	73	45	73		130B1795	130B1760	130B1778	130B1492
55.0	95	55	95		130B1796	130B1761	130B1779	130B1493
75.0	118	75	118		130B1797	130B1762	130B1780	130B1494
90	154	90	154		130B1798	130B1763	130B1781	130B1495

Table 6.10 Harmonic Filters for 440–480 V, 60 Hz

1) Frequency converter power and current ratings according to actual operating conditions.

Power and current ratings ¹⁾		Typical motor	Filter current rating		Ordering number AHF 005		Ordering number AHF 010	
			60 Hz		IP00	IP20	IP00	IP20
[kW]	[A]	[kW]	[A]	[A]				
11.0	15	10	15		130B5261	130B5246	130B5229	130B5212
15.0	19	16.4	20		130B5262	130B5247	130B5230	130B5213
18.0	24	20	24		130B5263	130B5248	130B5231	130B5214
22.0	29	24	29		130B5263	130B5248	130B5231	130B5214
30.0	36	33	36		130B5265	130B5250	130B5233	130B5216
37.0	49	40	50		130B5266	130B5251	130B5234	130B5217
45.0	58	50	58		130B5267	130B5252	130B5235	130B5218
55.0	74	60	77		130B5268	130B5253	130B5236	130B5219
75.0	85	75	87		130B5269	130B5254	130B5237	130B5220
90	106	90	109		130B5270	130B5255	130B5238	130B5221

Table 6.11 Harmonic Filters for 600 V, 60 Hz

Power and current ratings ¹⁾		Typical motor	Power and current ratings		Typical motor	Filter current rating	Ordering number AHF 005		Ordering number AHF 010	
			551–690 V				50 Hz		IP00	IP20
[kW]	[A]	[kW]	[kW]	[A]	[kW]	[A]				
11.0	15	7.5	P15K	16	15	15	130B5000	130B5088	130B5297	130B5280
15.0	19.5	11	P18K	20	18.5	20	130B5017	130B5089	130B5298	130B5281
18.0	24	15	P22K	25	22	24	130B5018	130B5090	130B5299	130B5282
22.0	29	18.5	P30K	31	30	29	130B5019	130B5092	130B5302	130B5283
30.0	36	22	P37K	38	37	36	130B5021	130B5125	130B5404	130B5284
37.0	49	30	P45K	48	45	50	130B5022	130B5144	130B5310	130B5285
45.0	59	37	P55K	57	55	58	130B5023	130B5168	130B5324	130B5286
55.0	71	45	P75K	76	75	77	130B5024	130B5169	130B5325	130B5287
75.0	89	55	–	–	–	87	130B5025	130B5170	130B5326	130B5288
90.0	110	90	–	–	–	109	130B5026	130B5172	130B5327	130B5289

Table 6.12 Harmonic Filters for 500–690 V, 50 Hz

1) Frequency converter power and current ratings according to actual operating conditions.

6.2.6 Sine-wave Filters

Frequency converter power and current ratings						Filter current rating			Switching frequency	Ordering number	
200–240 V		380–440 V		441–500 V		50 Hz	60 Hz	100 Hz		[kHz]	IP00
[kW]	[A]	[kW]	[A]	[kW]	[A]	[A]	[A]	[A]			
–	–	1.1	3	1.1	3	4.5	4	3.5	5	130B2406	130B2441
–	–	1.5	4.1	1.5	3.4						
–	–	2.2	5.6	2.2	4.8	8	7.5	5.5	5	130B2408	130B2443
1.1	6.6	3	7.2	3	6.3						
1.5	7.5	–	–	–	–						
–	–	4	10	4	8.2	10	9.5	7.5	5	130B2409	130B2444
2.2	10.6	5.5	13	5.5	11	17	16	13	5	130B2411	130B2446
3	12.5	7.5	16	7.5	14.5						
3.7	16.7	–	–	–	–						
5.5	24.2	11	24	11	21	24	23	18	4	130B2412	130B2447
7.5	30.8	15	32	15	27	38	36	28.5	4	130B2413	130B2448
		18.5	37.5	18.5	34						
11	46.2	22	44	22	40	48	45.5	36	4	130B2281	130B2307
15	59.4	30	61	30	52	62	59	46.5	3	130B2282	130B2308
18.5	74.8	37	73	37	65	75	71	56	3	130B2283	130B2309
22	88	45	90	55	80	115	109	86	3	130B3179	130B3181*
30	115	55	106	75	105						
37	143	75	147	90	130						
45	170	90	177			180	170	135	3	130B3182	130B3183*

Table 6.13 Sine-wave Filters for Frequency Converters with 380–500 V

1) Ordering numbers marked with * are IP23.

Frequency converter power and current ratings						Filter current rating @690 V			Switching frequency	Ordering number	
525–600 V		551–690 V		525–550 V		50 Hz	60 Hz	100 Hz		kHz	IP00
[kW]	[A]	[kW]	[A]	[kW]	[A]	[A]	[A]	[A]			
1.1	2.4	1.5	2.2	1.5	2.7	4.5	4	3	4	130B7335	130B7356
1.5	2.7	2.2	3.2	2.2	3.9						
2.2	3.9	3.0	4.5	3.0	4.9						
3	4.9	4.0	5.5	4.0	6.1	10	9	7	4	130B7289	130B7324
4	6.1	5.5	7.5	5.5	9.0						
5.5	9	7.5	10	7.5	11						
7.5	11	11	13	7.5	14	13	12	9	3	130B3195	130B3196
11	18	15	18	11	19	28	26	21	3	130B4112	130B4113
15	22	18.5	22	15	23						
18.5	27	22	27	18	28						
22	34	30	34	22	36	45	42	33	3	130B4114	130B4115
30	41	37	41	30	48						
37	52	45	52	37	54						
45	62	55	62	45	65	76	72	57	3	130B4116	130B4117*
55	83	75	83	55	87						
75	100	90	100	75	105	115	109	86	3	130B4118	130B4119*
90	131	–	–	90	137						
						165	156	124	2	130B4121	130B4124*

Table 6.14 Sine-wave Filters for Frequency Converters with 525–600 V and 525–690 V

1) Ordering numbers marked with * are IP23.

Parameter	Setting
Parameter 14-00 Switching Pattern	[1] SFAVM
Parameter 14-01 Switching Frequency	Set according to the individual filter. Listed on filter product label and in output filter manual. Sine-wave filters do not allow lower switching frequency than specified by the individual filter.
Parameter 14-55 Output Filter	[2] Sine-wave filter fixed
Parameter 14-56 Capacitance Output Filter	Set according to the individual filter. Listed on filter product label and in output filter manual (only required for flux operation).
Parameter 14-57 Inductance Output Filter	Set according to the individual filter. Listed on filter product label and in output filter manual (only required for flux operation).

Table 6.15 Parameter Settings for Sine-wave Filter Operation

6.2.7 dU/dt Filters

Frequency converter ratings [V]										Filter current rating [V]				Ordering number		
200–240		380–440		441–500		525–550		551–690		380 @60 Hz 200-400/ 440@50 Hz	460/480 @60 Hz 500/525 @50 Hz	575/600 @60 Hz	690 @50 Hz	IP00	IP20 ¹⁾	IP54
[kW]	[A]	[kW]	[A]	[kW]	[A]	[kW]	[A]	[kW]	[A]	[A]	[A]	[A]	[A]			
3	12.5	5.5	13	5.5	11	5.5	9.5	1.1	1.6	17	15	13	10	N/A	130B7367*	N/A
3.7	16	7.5	16	7.5	14.5	7.5	11.5	1.5	2.2							
–	–	–	–	–	–	–	–	2.2	3.2							
–	–	–	–	–	–	–	–	3	4.5							
–	–	–	–	–	–	–	–	4	5.5							
–	–	–	–	–	–	–	–	5.5	7.5							
–	–	–	–	–	–	–	–	7.5	10							
5.5	24.2	11	24	11	21	7.5	14	11	13	44	40	32	27	130B2835	130B2836*	130B2837
7.5	30.8	15	32	15	27	11	19	15	18							
–	–	18.5	37.5	18.5	34	15	23	18.5	22							
–	–	22	44	22	40	18.5	28	22	27							
11	46.2	30	61	30	52	30	43	30	34	90	80	58	54	130B2838	130B2839*	130B2840
15	59.4	37	73	37	65	37	54	37	41							
18.5	74.8	45	90	55	80	45	65	45	52							
22	88	–	–	–	–	–	–	–	–							
–	–	–	–	–	–	–	–	–	–	106	105	94	86	130B2841	130B2842*	130B2843
–	–	55	106	75	105	55	87	55	62							
–	–	–	–	–	–	–	–	75	83							
30	115	75	147	90	130	75	113	90	108	177	160	131	108	130B2844	130B2845*	130B2846
37	143	90	177	–	–	90	137	–	–							
45	170	–	–	–	–	–	–	–	–							

Table 6.16 dU/dt Filters for 200–690 V

1) Dedicated A3 enclosure sizes supporting foot print mounting and book style mounting. Fixed screened cable connection to frequency converter.

Parameter	Setting
Parameter 14-01 Switching Frequency	Higher operating switching frequency than specified by the individual filter is not recommended.
Parameter 14-55 Output Filter	[0] No filter
Parameter 14-56 Capacitance Output Filter	Not used
Parameter 14-57 Inductance Output Filter	Not used

Table 6.17 Parameter Settings for dU/dt Filter Operation

6.2.8 Common Mode Filters

Enclosure size	Ordering number	Core dimension					Weight [kg]
		W	w	H	h	d	
A and B	130B3257	60	43	40	25	22.3	0.25
C1	130B7679	82.8	57.5	45.5	20.6	33	–
C2, C3, C4	130B3258	102	69	61	28	37	1.6

Table 6.18 Common Mode Filters, Ordering Numbers

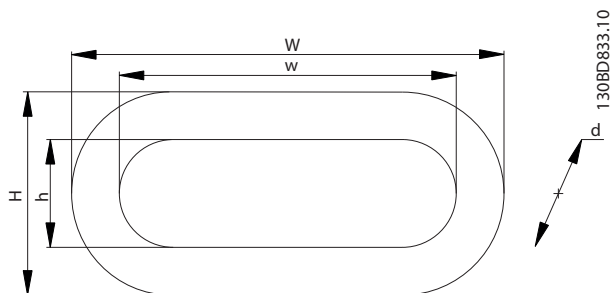

Illustration 6.2 HF-CM Core

7 Specifications

7.1 Electrical Data

7.1.1 Mains Supply 3x200–240 V AC

Type designation	P1K1	P1K5	P2K2	P3K0	P3K7
Overload ¹⁾	NO	NO	NO	NO	NO
Typical shaft output [kW]	1.1	1.5	2.2	3.0	3.7
Typical shaft output [hp] at 208 V	1.5	2.0	2.9	4.0	4.9
IP20/chassis ⁶⁾	A2	A2	A2	A3	A3
IP55/NEMA 12	A4/A5	A4/A5	A4/A5	A5	A5
IP66/NEMA 4X	A4/A5	A4/A5	A4/A5	A5	A5
Output current					
Continuous (3x200–240 V) [A]	6.6	7.5	10.6	12.5	16.7
Intermittent (3x200–240 V) [A]	7.3	8.3	11.7	13.8	18.4
Continuous kVA (208 V AC) [kVA]	2.38	2.70	3.82	4.50	6.00
Maximum input current					
Continuous (3x200–240 V) [A]	5.9	6.8	9.5	11.3	15.0
Intermittent (3x200–240 V) [A]	6.5	7.5	10.5	12.4	16.5
More specifications					
Estimated power loss ³⁾ at rated maximum load [W] ⁴⁾	63	82	116	155	185
IP20, IP21 maximum cable cross-section ²⁾ (mains, motor, brake, and load sharing) [mm ² /(AWG)]	4, 4, 4 (12, 12, 12) (minimum 0.2 (24))				
IP55, IP66 maximum cable cross-section ²⁾ (mains, motor, brake, and load sharing) [mm ² /(AWG)]	4, 4, 4 (12, 12, 12)				
Maximum cable cross-section with disconnect	6, 4, 4 (10, 12, 12)				
Efficiency ⁵⁾	0.96	0.96	0.96	0.96	0.96

Table 7.1 Mains Supply 3x200–240 V AC

Type designation	P5K5	P7K5	P11K	P15K	P18K	P22K	P30K	P37K	P45K
Overload ¹⁾	NO	NO	NO	NO	NO	NO	NO	NO	NO
Typical shaft output [kW]	5.5	7.5	11	15	18.5	22	30	37	45
Typical shaft output [hp] at 208 V	7.5	10	15	20	25	30	40	50	60
IP20/chassis ⁶⁾	B3	B3	B3	B4	B4	C3	C3	C4	C4
IP21/NEMA 1	B1	B1	B1	B2	C1	C1	C1	C2	C2
IP55/NEMA 12	B1	B1	B1	B2	C1	C1	C1	C2	C2
IP66/NEMA 4X	B1	B1	B1	B2	C1	C1	C1	C2	C2
Output current									
Continuous (3x200–240 V) [A]	24.2	30.8	46.2	59.4	74.8	88.0	115	143	170
Intermittent (3x200–240 V) [A]	26.6	33.9	50.8	65.3	82.3	96.8	127	157	187
Continuous kVA (208 V AC) [kVA]	8.7	11.1	16.6	21.4	26.9	31.7	41.4	51.5	61.2
Maximum input current									
Continuous (3x200–240 V) [A]	22.0	28.0	42.0	54.0	68.0	80.0	104.0	130.0	154.0
Intermittent (3x200–240 V) [A]	24.2	30.8	46.2	59.4	74.8	88.0	114.0	143.0	169.0
More specifications									
Estimated power loss ³⁾ at rated maximum load [W] ⁴⁾	269	310	447	602	737	845	1140	1353	1636
IP20 maximum cable cross-section ²⁾ (mains, brake, motor, and load sharing) [mm ² /(AWG)]	10, 10 (8, 8, -)			35 (2)		50 (1)		150 (300 MCM)	
IP21, IP55, IP66 maximum cable cross-section ²⁾ (mains, motor) [mm ² /(AWG)]	16, 10, 16 (6, 8, 6)			35, -, - (2, -, -)		50 (1)		150 (300 MCM)	
Efficiency ⁵⁾	0.96	0.96	0.96	0.96	0.96	0.97	0.97	0.97	0.97

Table 7.2 Mains Supply 3x200–240 V AC

7.1.2 Mains Supply 3x380–480 V AC

Type designation	P1K1	P1K5	P2K2	P3K0	P4K0	P5K5	P7K5
Overload ¹⁾	NO	NO	NO	NO	NO	NO	NO
Typical shaft output [kW]	1.1	1.5	2.2	3.0	4.0	5.5	7.5
Typical shaft output [hp] at 460 V	1.5	2.0	2.9	4.0	5.0	7.5	10
IP20/chassis ⁶⁾	A2	A2	A2	A2	A2	A3	A3
IP55/NEMA 12	A4/A5	A4/A5	A4/A5	A4/A5	A4/A5	A5	A5
IP66/NEMA 4X	A4/A5	A4/A5	A4/A5	A4/A5	A4/A5	A5	A5
Output current							
Continuous (3x380–440 V) [A]	3	4.1	5.6	7.2	10	13	16
Intermittent (3x380–440 V) [A]	3.3	4.5	6.2	7.9	11	14.3	17.6
Continuous (3x441–480 V) [A]	2.7	3.4	4.8	6.3	8.2	11	14.5
Intermittent (3x441–480 V) [A]	3.0	3.7	5.3	6.9	9.0	12.1	15.4
Continuous kVA (400 V AC) [kVA]	2.1	2.8	3.9	5.0	6.9	9.0	11.0
Continuous kVA (460 V AC) [kVA]	2.4	2.7	3.8	5.0	6.5	8.8	11.6
Maximum input current							
Continuous (3x380–440 V) [A]	2.7	3.7	5.0	6.5	9.0	11.7	14.4
Intermittent (3x380–440 V) [A]	3.0	4.1	5.5	7.2	9.9	12.9	15.8
Continuous (3x441–480 V) [A]	2.7	3.1	4.3	5.7	7.4	9.9	13.0
Intermittent (3x441–480 V) [A]	3.0	3.4	4.7	6.3	8.1	10.9	14.3
More specifications							
Estimated power loss ³⁾ at rated maximum load [W] ⁴⁾	58	62	88	116	124	187	255
IP20, IP21 maximum cable cross-section ²⁾ (mains, motor, brake, and load sharing) [mm ² /(AWG)] ²⁾	4, 4, 4 (12, 12, 12) (minum 0.2 (24))						
IP55, IP66 maximum cable cross-section ²⁾ (mains, motor, brake, and load sharing) [mm ² /(AWG)] ²⁾	4, 4, 4 (12, 12, 12)						
Maximum cable cross-section ²⁾ with disconnect	6, 4, 4 (10, 12, 12)						
Efficiency ⁵⁾	0.96	0.97	0.97	0.97	0.97	0.97	0.97

Table 7.3 Mains Supply 3x380–480 V AC

Type designation	P11K	P15K	P18K	P22K	P30K	P37K	P45K	P55K	P75K	P90K
Overload ¹⁾	NO	NO	NO	NO	NO	NO	NO	NO	NO	NO
Typical shaft output [kW]	11	15	18.5	22	30	37	45	55	75	90
Typical shaft output [hp] at 460 V	15	20	25	30	40	50	60	75	100	125
IP20/chassis ⁷⁾	B3	B3	B3	B4	B4	B4	C3	C3	C4	C4
IP21/NEMA 1	B1	B1	B1	B2	B2	C1	C1	C1	C2	C2
IP55/NEMA 12	B1	B1	B1	B2	B2	C1	C1	C1	C2	C2
IP66/NEMA 4X	B1	B1	B1	B2	B2	C1	C1	C1	C2	C2
Output current										
Continuous (3x380–439 V) [A]	24	32	37.5	44	61	73	90	106	147	177
Intermittent (3x380–439 V) [A]	26.4	35.2	41.3	48.4	67.1	80.3	99	117	162	195
Continuous (3x440–480 V) [A]	21	27	34	40	52	65	80	105	130	160
Intermittent (3x440–480 V) [A]	23.1	29.7	37.4	44	61.6	71.5	88	116	143	176
Continuous kVA (400 V AC) [kVA]	16.6	22.2	26	30.5	42.3	50.6	62.4	73.4	102	123
Continuous kVA (460 V AC) [kVA]	16.7	21.5	27.1	31.9	41.4	51.8	63.7	83.7	104	128
Maximum input current										
Continuous (3x380–439 V) [A]	22	29	34	40	55	66	82	96	133	161
Intermittent (3x380–439 V) [A]	24.2	31.9	37.4	44	60.5	72.6	90.2	106	146	177
Continuous (3x440–480 V) [A]	19	25	31	36	47	59	73	95	118	145
Intermittent (3x440–480 V) [A]	20.9	27.5	34.1	39.6	51.7	64.9	80.3	105	130	160
More specifications										
Estimated power loss ³⁾ at rated maximum load [W] ⁴⁾	278	392	465	525	698	739	843	1083	1384	1474
IP20 maximum cable cross-section ²⁾ (mains, brake, motor, and load sharing) [mm ² /(AWG)]	10, 10, - (8, 8, -)			35, -, - (2, -, -)			50 (1)		95 (4/0)	
IP21, IP55, IP66 maximum cable cross-section ²⁾ (mains, motor) [mm ² /(AWG)]	10, 10, - (8, 8, -)			35, 25, 25 (2, 4, 4)			50 (1)		150 (300 MCM)	
With mains disconnect switch included:	16, 10, 10 (6, 8, 8)					50, 35, 35 (1, 2, 2)			95, 70, 70 (3/0, 2/70, 2/0)	185, 150, 120 (350 MCM, 300 MCM, 4/0)
Efficiency ⁵⁾	0.98	0.98	0.98	0.98	0.98	0.98	0.98	0.98	0.98	0.99

Table 7.4 Mains Supply 3x380–480 V AC

7.1.3 Mains Supply 3x525–600 V AC

Type designation	P1K1	P1K5	P2K2	P3K0	P3K7	P4K0	P5K5	P7K5
Overload ¹⁾	NO	NO	NO	NO	NO	NO	NO	NO
Typical shaft output [kW]	1.1	1.5	2.2	3.0	3.7	4.0	5.5	7.5
IP20/chassis	A3	A3	A3	A3	A2	A3	A3	A3
IP21/NEMA 1	A3	A3	A3	A3	A2	A3	A3	A3
IP55/NEMA 12	A5	A5	A5	A5	A5	A5	A5	A5
IP66/NEMA 4X	A5	A5	A5	A5	A5	A5	A5	A5
Output current								
Continuous (3x525–550 V) [A]	2.6	2.9	4.1	5.2	–	6.4	9.5	11.5
Intermittent (3x525–550 V) [A]	2.9	3.2	4.5	5.7	–	7.0	10.5	12.7
Continuous (3x525–600 V) [A]	2.4	2.7	3.9	4.9	–	6.1	9.0	11.0
Intermittent (3x525–600 V) [A]	2.6	3.0	4.3	5.4	–	6.7	9.9	12.1
Continuous kVA (525 V AC) [kVA]	2.5	2.8	3.9	5.0	–	6.1	9.0	11.0
Continuous kVA (575 V AC) [kVA]	2.4	2.7	3.9	4.9	–	6.1	9.0	11.0
Maximum input current								
Continuous (3x525–600 V) [A]	2.4	2.7	4.1	5.2	–	5.8	8.6	10.4
Intermittent (3x525–600 V) [A]	2.7	3.0	4.5	5.7	–	6.4	9.5	11.5
More specifications								
Estimated power loss ³⁾ at rated maximum load [W] ⁴⁾	50	65	92	122	–	145	195	261
IP20 maximum cable cross-section ²⁾ (mains, motor, brake, and load sharing) [mm ² /(AWG)]	4, 4, 4 (12, 12, 12) (minmum 0.2 (24))							
IP55, IP66 maximum cable cross- section ²⁾ (mains, motor, brake, and load sharing) [mm ² /(AWG)]	4, 4, 4 (12, 12, 12) (minmum 0.2 (24))							
Maximum cable cross-section ²⁾ with disconnect	6, 4, 4 (10, 12, 12)							
Efficiency ⁵⁾	0.97	0.97	0.97	0.97	–	0.97	0.97	0.97

7

Table 7.5 Mains Supply 3x525–600 V AC

Type designation	P11K	P15K	P18K	P22K	P30K	P37K	P45K	P55K	P75K	P90K
Overload ¹⁾	NO	NO	NO	NO	NO	NO	NO	NO	NO	NO
Typical shaft output [kW]	11	15	18.5	22	30	37	45	55	75	90
IP20/chassis	B3	B3	B3	B4	B4	B4	C3	C3	C4	C4
IP21/NEMA 1	B1	B1	B1	B2	B2	C1	C1	C1	C2	C2
IP55/NEMA 12	B1	B1	B1	B2	B2	C1	C1	C1	C2	C2
IP66/NEMA 4X	B1	B1	B1	B2	B2	C1	C1	C1	C2	C2
Output current										
Continuous (3x525–550 V) [A]	19	23	28	36	43	54	65	87	105	137
Intermittent (3x525–550 V) [A]	21	25	31	40	47	59	72	96	116	151
Continuous (3x525–600 V) [A]	18	22	27	34	41	52	62	83	100	131
Intermittent (3x525–600 V) [A]	20	24	30	37	45	57	68	91	110	144
Continuous kVA (525 V AC) [kVA]	18.1	21.9	26.7	34.3	41	51.4	61.9	82.9	100	130.5
Continuous kVA (575 V AC) [kVA]	17.9	21.9	26.9	33.9	40.8	51.8	61.7	82.7	99.6	130.5
Maximum input current										
Continuous (3x525–600 V) [A]	17.2	20.9	25.4	32.7	39	49	59	78.9	95.3	124.3
Intermittent (3x525–600 V) [A]	19	23	28	36	43	54	65	87	105	137
More specifications										
Estimated power loss ³⁾ at rated maximum load [W] ⁴⁾	300	400	475	525	700	750	850	1100	1400	1500
IP21, IP55, IP66 maximum cable cross-section ²⁾ (mains, brake, and load sharing) [mm ² / (AWG)]	16, 10, 10 (6, 8, 8)			35, -, - (2, -, -)			50, -, - (1, -, -)			150 (300 MCM)
IP21, IP55, IP66 maximum cable cross-section ²⁾ (motor) [mm ² / (AWG)]	10, 10, - (8, 8, -)			35, 25, 25 (2, 4, 4)			50, -, - (1, -, -)			150 (300 MCM)
IP20 maximum cable cross-section ²⁾ (mains, brake, and load sharing) [mm ² / (AWG)]	10, 10, - (8, 8, -)			35, -, - (2, -, -)			50, -, - (1, -, -)			150 (300 MCM)
Maximum cable cross-section ²⁾ with disconnect	16, 10, 10 (6, 8, 8)						50, 35, 35 (1, 2, 2)			95, 70, 70 (3/0, 2/0, 2/0) 185, 150, 120 (350 MCM, 300 MCM, 4/0)
Efficiency ⁵⁾	0.98	0.98	0.98	0.98	0.98	0.98	0.98	0.98	0.98	0.98

Table 7.6 Mains Supply 3x525–600 V AC

For type of fuse, see chapter 7.8 Fuses and Circuit Breakers.

1) Normal overload 110% torque for a duration of 60 s.

2) The 3 values for the maximum cable cross-section are for single core, flexible wire, and flexible wire with sleeve, respectively.

3) Applies for dimensioning of frequency converter cooling. If the switching frequency is higher than the default setting, the power losses may increase. LCP and typical control card power consumptions are included. For power loss data according to EN 50598-2, refer to www.danfoss.com/vltenergyefficiency.

4) Efficiency measured at nominal current. For energy efficiency class, see chapter 7.4 Ambient Conditions. For part load losses, see www.danfoss.com/vltenergyefficiency.

5) Measured using 5 m screened motor cables at rated load and rated frequency.

6) Enclosure sizes A2+A3 can be converted to IP21 using a conversion kit. See also chapter 3.7 Mechanical Planning.

7) Enclosure sizes B3+B4 and C3+C4 can be converted to IP21 using a conversion kit. See also chapter 3.7 Mechanical Planning.

7.2 Mains Supply

Mains supply

Supply terminals	L1, L2, L3
Supply voltage	200–240 V ±10%
Supply voltage	380–480 V ±10%
Supply voltage	525–600 V ±10%

Mains voltage low/mains drop-out:

During low mains voltage or a mains drop-out, the frequency converter continues until the DC-link voltage drops below the minimum stop level. The minimum stop level corresponds typically to 15% below the frequency converter's lowest rated supply voltage. Power-up and full torque cannot be expected at mains voltage lower than 10% below the frequency converter's lowest rated supply voltage.

Supply frequency	50/60 Hz ±5%
Maximum imbalance temporary between mains phases	3.0% of rated supply voltage
True power factor (λ)	≥0.9 nominal at rated load
Displacement power factor ($\cos \phi$)	Near unity (>0.98)
Switching on input supply L1, L2, L3 (power-ups) ≤7.5 kW	Maximum 2 times/minutes
Switching on input supply L1, L2, L3 (power-ups) 11–75 kW	Maximum 1 time/minute
Switching on input supply L1, L2, L3 (power-ups) ≥90 kW	Maximum 1 time/2 minutes
Environment according to EN60664-1	Overvoltage category III/pollution degree 2

The unit is suitable for use on a circuit capable of delivering not more than 100000 RMS symmetrical Amperes, 240/500/600/690 V maximum.

7.3 Motor Output and Motor Data

Motor output (U, V, W)

Output voltage	0–100% of supply voltage
Output frequency (1.1–90 kW)	0–590 ¹⁾ Hz
Switching on output	Unlimited
Ramp times	1–3600 s

1) From software version 1.10 the output frequency of the frequency converter is limited to 590 Hz. Contact the local Danfoss partner for further information.

Torque characteristics

Starting torque (constant torque)	Maximum 110% for 60 s ¹⁾
Starting torque	Maximum 135% up to 0.5 s ¹⁾
Overload torque (constant torque)	Maximum 110% for 60 s ¹⁾

1) Percentage relates to the nominal torque.

7.4 Ambient Conditions

Environment

IP rating	IP20 ¹⁾ /Chassis, IP21 ²⁾ /Type 1, IP55/Type 12, IP66/Type 4X
Vibration test	1.0 g
Maximum relative humidity	5–93% (IEC 721-3-3; Class 3K3 (non-condensing) during operation
Aggressive environment (IEC 60068-2-43) H ₂ S test	Class Kd
Ambient temperature ³⁾	Maximum 50 °C (24-hour average maximum 45 °C)
Minimum ambient temperature during full-scale operation	0 °C
Minimum ambient temperature at reduced performance	-10 °C
Temperature during storage/transport	-25 to +65/70 °C
Maximum altitude above sea level without derating	1000 m

Derating for high altitude, see special conditions in the Design Guide

EMC standards, Emission	EN 61800-3
EMC standards, Immunity	EN 61800-3
Energy efficiency class ⁴⁾	IE2

See chapter 5 Special Conditions.

1) Only for ≤3.7 kW (200–240 V), ≤7.5 kW (380–480 V).

2) As enclosure kit for ≤3.7 kW (200–240 V), ≤7.5 kW (380–480 V).

3) Derating for high ambient temperature, see chapter 5 Special Conditions.

4) Determined according to EN 50598-2 at:

- Rated load.
- 90% rated frequency.
- Switching frequency factory setting.
- Switching pattern factory setting.

7.5 Cable Specifications

Cable lengths and cross-sections for control cables¹⁾

Maximum motor cable length, screened	150 m (492 ft)
Maximum motor cable length, unscreened	300 m (984 ft)
Maximum cross-section to control terminals, flexible/rigid wire without cable end sleeves	1.5 mm ² /16 AWG
Maximum cross-section to control terminals, flexible wire with cable end sleeves	1 mm ² /18 AWG
Maximum cross-section to control terminals, flexible wire with cable end sleeves with collar	0.5 mm ² /20 AWG
Minimum cross-section to control terminals	0.25 mm ² /24 AWG

1) For power cables, see electrical data tables in chapter 7.1 Electrical Data.

7.5.1 Cable Lengths for Multiple Parallel Motor Connections

Enclosure sizes	Power size [kW]	Voltage [V]	1 cable [m]	2 cables [m]	3 cables [m]	4 cables [m]
A2, A4, A5	1.1–1.5	400	150	45	20	8
A2, A4, A5	2.2–4	400	150	45	20	11
A3, A4, A5	5.5–7.5	400	150	45	20	11
B1, B2, B3, B4, C1, C2, C3, C4	11–90	400	150	75	50	37

Table 7.7 Maximum Cable Length for Each Parallel Cable

For more information, refer to chapter 3.5.6 Connection of Multiple Motors.

7.6 Control Input/Output and Control Data

Digital inputs

Programmable digital inputs	4 (6) ¹⁾
Terminal number	18, 19, 27 ¹⁾ , 29 ¹⁾ , 32, 33
Logic	PNP or NPN
Voltage level	0–24 V DC
Voltage level, logic 0 PNP	<5 V DC
Voltage level, logic 1 PNP	>10 V DC
Voltage level, logic 0 NPN ²⁾	>19 V DC
Voltage level, logic 1 NPN ²⁾	<14 V DC
Maximum voltage on input	28 V DC
Pulse frequency range	0–110 kHz
(Duty cycle) Min. pulse width	4.5 ms
Input resistance, R _i	Approximately 4 kΩ

Safe Torque Off (STO) Terminal 37^{3), 4)} (Terminal 37 is fixed PNP logic)

Voltage level	0–24 V DC
Voltage level, logic 0 PNP	<4 V DC
Voltage level, logic 1 PNP	>20 V DC
Maximum voltage on input	28 V DC
Typical input current at 24 V	50 mA _{rms}
Typical input current at 20 V	60 mA _{rms}
Input capacitance	400 nF

All digital inputs are galvanically isolated from the supply voltage (PELV) and other high-voltage terminals.

1) Terminals 27 and 29 can also be programmed as output.

2) Except safe torque off input terminal 37.

3) See VLT[®] Frequency Converters – Safe Torque Off Operating Instructions for further information about terminal 37 and safe torque off.

4) When using a contactor with a DC coil in combination with STO, always make a return path for the current from the coil when turning it off. The return path can be made by using a freewheel diode (or, alternatively, a 30 V or 50 V MOV for quicker response time) across the coil. Typical contactors can be bought with this diode.

Analog inputs

Number of analog inputs	2
Terminal number	53, 54
Modes	Voltage or current
Mode select	Switch S201 and switch S202
Voltage mode	Switch S201/switch S202=OFF (U)
Voltage level	-10 V to +10 V (scaleable)
Input resistance, R_i	Approximately 10 k Ω
Maximum voltage	± 20 V
Current mode	Switch S201/switch S202=ON (I)
Current level	0/4 to 20 mA (scaleable)
Input resistance, R_i	Approximately 200 Ω
Maximum current	30 mA
Resolution for analog inputs	10 bit (+ sign)
Accuracy of analog inputs	Maximum error 0.5% of full scale
Bandwidth	100 Hz

The analog inputs are galvanically isolated from the supply voltage (PELV) and other high-voltage terminals.

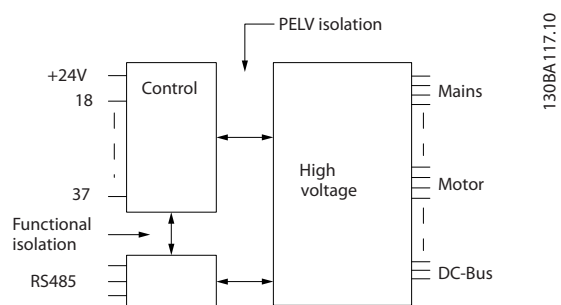

Illustration 7.1 PELV Isolation of Analog Inputs

Pulse inputs

Programmable pulse	2/1
Terminal number pulse	29, 33 ¹⁾ /32 ²⁾ , 33 ²⁾
Maximum frequency at terminal 29, 32, 33	110 kHz (Push-pull driven)
Maximum frequency at terminal 29, 32, 33	5 kHz (open collector)
Minimum frequency at terminal 29, 32, 33	4 Hz
Voltage level	See chapter 7.6.1 Digital Inputs
Maximum voltage on input	28 V DC
Input resistance, R_i	Approximately 4 k Ω
Pulse input accuracy (0.1–1 kHz)	Maximum error: 0.1% of full scale
Encoder input accuracy (1–11 kHz)	Maximum error: 0.05% of full scale

The pulse and encoder inputs (terminals 29, 32, 33) are galvanically isolated from the supply voltage (PELV) and other high-voltage terminals.

1) Pulse inputs are 29 and 33.

2) Encoder inputs: 32=A, and 33=B.

Analog output

Number of programmable analog outputs	1
Terminal number	42
Current range at analog output	0/4–20 mA
Maximum load GND - analog output	500 Ω
Accuracy on analog output	Maximum error: 0.5% of full scale
Resolution on analog output	12 bit

The analog output is galvanically isolated from the supply voltage (PELV) and other high-voltage terminals.

Control card, RS485 serial communication

Terminal number	68 (P, TX+, RX+), 69 (N, TX-, RX-)
Terminal number 61	Common for terminals 68 and 69

The RS485 serial communication circuit is functionally separated from other central circuits and galvanically isolated from the supply voltage (PELV).

Digital output

Programmable digital/pulse outputs	2
Terminal number	27, 29 ¹⁾
Voltage level at digital/frequency output	0–24 V
Maximum output current (sink or source)	40 mA
Maximum load at frequency output	1 kΩ
Maximum capacitive load at frequency output	10 nF
Minimum output frequency at frequency output	0 Hz
Maximum output frequency at frequency output	32 kHz
Accuracy of frequency output	Maximum error: 0.1% of full scale
Resolution of frequency outputs	12 bit

1) Terminals 27 and 29 can also be programmed as input.

The digital output is galvanically isolated from the supply voltage (PELV) and other high-voltage terminals.

Control card, 24 V DC output

Terminal number	12, 13
Output voltage	24 V +1, -3 V
Maximum load	200 mA

The 24 V DC supply is galvanically isolated from the supply voltage (PELV), but has the same potential as the analog and digital inputs and outputs.

Relay outputs

Programmable relay outputs	
Relay 01 terminal number	1–3 (break), 1–2 (make)
Maximum terminal load (AC-1) ¹⁾ on 1–3 (NC), 1–2 (NO) (Resistive load)	240 V AC, 2 A
Maximum terminal load (AC-15) ¹⁾ (Inductive load @ cosφ 0.4)	240 V AC, 0.2 A
Maximum terminal load (DC-1) ¹⁾ on 1–2 (NO), 1–3 (NC) (Resistive load)	60 V DC, 1 A
Maximum terminal load (DC-13) ¹⁾ (Inductive load)	24 V DC, 0.1 A
Relay 02 terminal number	4–6 (break), 4–5 (make)
Maximum terminal load (AC-1) ¹⁾ on 4–5 (NO) (Resistive load) ²⁾³⁾ Overvoltage category II	400 V AC, 2 A
Maximum terminal load (AC-15) ¹⁾ on 4–5 (NO) (Inductive load @ cosφ 0.4)	240 V AC, 0.2 A
Maximum terminal load (DC-1) ¹⁾ on 4–5 (NO) (Resistive load)	80 V DC, 2 A
Maximum terminal load (DC-13) ¹⁾ on 4–5 (NO) (Inductive load)	24 V DC, 0.1 A
Maximum terminal load (AC-1) ¹⁾ on 4–6 (NC) (Resistive load)	240 V AC, 2 A
Maximum terminal load (AC-15) ¹⁾ on 4–6 (NC) (Inductive load @ cosφ 0.4)	240 V AC, 0.2 A
Maximum terminal load (DC-1) ¹⁾ on 4–6 (NC) (Resistive load)	50 V DC, 2 A
Maximum terminal load (DC-13) ¹⁾ on 4–6 (NC) (Inductive load)	24 V DC, 0.1 A
Minimum terminal load on 1–3 (NC), 1–2 (NO), 4–6 (NC), 4–5 (NO)	24 V DC 10 mA, 24 V AC 20 mA
Environment according to EN 60664-1	Overvoltage category III/pollution degree 2

1) IEC 60947 part 4 and 5.

The relay contacts are galvanically isolated from the rest of the circuit by reinforced isolation (PELV).

2) Overvoltage Category II.

3) UL applications 300 V AC 2 A.

Control card, 10 V DC output

Terminal number	50
Output voltage	10.5 V ±0.5 V
Maximum load	15 mA

The 10 V DC supply is galvanically isolated from the supply voltage (PELV) and other high-voltage terminals.

Control characteristics

Resolution of output frequency at 0–590 Hz	± 0.003 Hz
Repeat accuracy of precise start/stop (terminals 18, 19)	≤± 0.1 ms
System response time (terminals 18, 19, 27, 29, 32, 33)	≤10 ms
Speed control range (open loop)	1:100 of synchronous speed
Speed control range (closed loop)	1:1000 of synchronous speed
Speed accuracy (open loop)	30–4000 RPM: error ±8 RPM
Speed accuracy (closed loop), depending on resolution of feedback device	0–6000 RPM: error ±0.15 RPM

All control characteristics are based on a 4-pole asynchronous motor.

Control card performance

Scan interval	5 ms
---------------	------

Control card, USB serial communication

USB standard	1.1 (full speed)
USB plug	USB type B device plug

Connection to PC is carried out via a standard host/device USB cable.

The USB connection is galvanically isolated from the supply voltage (PELV) and other high-voltage terminals.

The USB ground connection is NOT galvanically isolated from protective earth. Use only an isolated laptop as PC connection to the USB connector on the frequency converter.

7
7.7 Connection Tightening Torque

Enclosure	Power [kW]			Torque [Nm]			
	200–240 V	380–480 V	525–600 V	Mains	Motor	Ground	Relay
A2	1.1–2.2	1.1–4.0	–	1.8	1.8	3	0.6
A3	3.0–3.7	5.5–7.5	1.1–7.5	1.8	1.8	3	0.6
A4	1.1–2.2	1.1–4.0	–	1.8	1.8	3	0.6
A5	1.1–3.7	1.1–7.5	1.1–7.5	1.8	1.8	3	0.6
B1	5.5–11	11–18	11–18	1.8	1.8	3	0.6
B2	15	22–30	22–30	4.5	4.5	3	0.6
B3	5.5–11	11–18	11–18	1.8	1.8	3	0.6
B4	15–18	22–37	22–37	4.5	4.5	3	0.6
C1	18–30	37–55	37–55	10	10	3	0.6
C2	37–45	75–90	75–90	14/24 ¹⁾	14/24 ¹⁾	3	0.6
C3	22–30	45–55	45–55	10	10	3	0.6
C4	37–45	75–90	75–90	14/24 ¹⁾	14/24 ¹⁾	3	0.6

Table 7.8 Tightening of Terminals

1) For different cable dimensions x/y, where x ≤95 mm² and y ≥95 mm².

7.8 Fuses and Circuit Breakers

Use recommended fuses and/or circuit breakers on the supply side as protection if there is component break-down inside the frequency converter (first fault).

NOTICE

Use of fuses on the supply side is mandatory for IEC 60364 (CE) and NEC 2009 (UL) compliant installations.

Recommendations:

- gG type fuses.
- Moeller type circuit breakers. For other circuit breaker types, ensure that the energy into the frequency converter is equal to or lower than the energy provided by Moeller types.

Use of recommended fuses and circuit breakers ensures that possible damage to the frequency converter is limited to damages inside the unit. For further information, see *Application Note Fuses and Circuit Breakers*.

The fuses in *Table 7.9* to *Table 7.16* are suitable for use on a circuit capable of delivering 100000 A_{rms} (symmetrical), depending on the frequency converter voltage rating. With the proper fusing, the frequency converter short circuit current rating (SCCR) is 100000 A_{rms}.



7.8.1 CE Compliance

200–240 V

Enclosure type	Power [kW]	Recommended fuse size	Recommended maximum fuse size	Recommended circuit breaker (Moeller)	Maximum trip level [A]
A2	1.1–2.2	gG-10 (1.1–1.5) gG-16 (2.2)	gG-25	PKZM0-25	25
A3	3.0–3.7	gG-16 (3) gG-20 (3.7)	gG-32	PKZM0-25	25
B3	5.5–11	gG-25 (5.5–7.5) gG-32 (11)	gG-63	PKZM4-50	50
B4	15–18	gG-50 (15) gG-63 (18)	gG-125	NZMB1-A100	100
C3	22–30	gG-80 (22) aR-125 (30)	gG-150 (22) aR-160 (30)	NZMB2-A200	150
C4	37–45	aR-160 (37) aR-200 (45)	aR-200 (37) aR-250 (45)	NZMB2-A250	250
A4	1.1–2.2	gG-10 (1.1–1.5) gG-16 (2.2)	gG-32	PKZM0-25	25
A5	1.1–3.7	gG-10 (1.1–1.5) gG-16 (2.2–3) gG-20 (3.7)	gG-32	PKZM0-25	25
B1	5.5–11	gG-25 (5.5) gG-32 (7.5–11)	gG-80	PKZM4-63	63
B2	15	gG-50	gG-100	NZMB1-A100	100
C1	18–30	gG-63 (18.5) gG-80 (22) gG-100 (30)	gG-160 (18.5–22) aR-160 (30)	NZMB2-A200	160
C2	37–45	aR-160 (37) aR-200 (45)	aR-200 (37) aR-250 (45)	NZMB2-A250	250

Table 7.9 200–240 V, Enclosure Types A, B, and C

380–480 V

Enclosure type	Power [kW]	Recommended fuse size	Recommended maximum fuse size	Recommended circuit breaker (Moeller)	Maximum trip level [A]
A2	1.1–4.0	gG-10 (1.1–3) gG-16 (4)	gG-25	PKZM0-25	25
A3	5.5–7.5	gG-16	gG-32	PKZM0-25	25
B3	11–18	gG-40	gG-63	PKZM4-50	50
B4	22–37	gG-50 (22) gG-63 (30) gG-80 (37)	gG-125	NZMB1-A100	100
C3	45–55	gG-100 (45) gG-160 (55)	gG-150 (45) gG-160 (55)	NZMB2-A200	150
C4	75–90	aR-200 (75) aR-250 (90)	aR-250	NZMB2-A250	250
A4	1.1–4	gG-10 (1.1–3) gG-16 (4)	gG-32	PKZM0-25	25
A5	1.1–7.5	gG-10 (1.1–3) gG-16 (4–7.5)	gG-32	PKZM0-25	25
B1	11–18.5	gG-40	gG-80	PKZM4-63	63
B2	22–30	gG-50 (22) gG-63 (30)	gG-100	NZMB1-A100	100
C1	37–55	gG-80 (37) gG-100 (45) gG-160 (55)	gG-160	NZMB2-A200	160
C2	75–90	aR-200 (75) aR-250 (90)	aR-250	NZMB2-A250	250

Table 7.10 380–480 V, Enclosure Types A, B, and C
525–600 V

Enclosure type	Power [kW]	Recommended fuse size	Recommended maximum fuse size	Recommended circuit breaker (Moeller)	Maximum trip level [A]
A3	5.5–7.5	gG-10 (5.5) gG-16 (7.5)	gG-32	PKZM0-25	25
B3	11–18	gG-25 (11) gG-32 (15–18)	gG-63	PKZM4-50	50
B4	22–37	gG-40 (22) gG-50 (30) gG-63 (37)	gG-125	NZMB1-A100	100
C3	45–55	gG-63 (45) gG-100 (55)	gG-150	NZMB2-A200	150
C4	75–90	aR-160 (75) aR-200 (90)	aR-250	NZMB2-A250	250
A5	1.1–7.5	gG-10 (1.1–5.5) gG-16 (7.5)	gG-32	PKZM0-25	25
B1	11–18	gG-25 (11) gG-32 (15) gG-40 (18.5)	gG-80	PKZM4-63	63
B2	22–30	gG-50 (22) gG-63 (30)	gG-100	NZMB1-A100	100
C1	37–55	gG-63 (37) gG-100 (45) aR-160 (55)	gG-160 (37–45) aR-250 (55)	NZMB2-A200	160
C2	75–90	aR-200 (75–90)	aR-250	NZMB2-A250	250

Table 7.11 525–600 V, Enclosure Types A, B, and C

7.8.2 UL Compliance

3x200–240 V

Power [kW]	Recommended maximum fuse					
	Bussmann Type RK1 ¹⁾	Bussmann Type J	Bussmann Type T	Bussmann Type CC	Bussmann Type CC	Bussmann Type CC
1.1	KTN-R-10	JKS-10	JJN-10	FNQ-R-10	KTK-R-10	LP-CC-10
1.5	KTN-R-15	JKS-15	JJN-15	FNQ-R-15	KTK-R-15	LP-CC-15
2.2	KTN-R-20	JKS-20	JJN-20	FNQ-R-20	KTK-R-20	LP-CC-20
3.0	KTN-R-25	JKS-25	JJN-25	FNQ-R-25	KTK-R-25	LP-CC-25
3.7	KTN-R-30	JKS-30	JJN-30	FNQ-R-30	KTK-R-30	LP-CC-30
5.5/7.5	KTN-R-50	JKS-50	JJN-50	–	–	–
11	KTN-R-60	JKS-60	JJN-60	–	–	–
15	KTN-R-80	JKS-80	JJN-80	–	–	–
18.5–22	KTN-R-125	JKS-125	JJN-125	–	–	–
30	KTN-R-150	JKS-150	JJN-150	–	–	–
37	KTN-R-200	JKS-200	JJN-200	–	–	–
45	KTN-R-250	JKS-250	JJN-250	–	–	–

7

Table 7.12 3x200–240 V, Enclosure Types A, B, and C

Power [kW]	Recommended maximum fuse							
	SIBA Type RK1	Littelfuse Type RK1	Ferraz Shawmut Type CC	Ferraz Shawmut Type RK1 ³⁾	Bussmann Type JFHR2 ²⁾	Littelfuse JFHR2	Ferraz Shawmut JFHR2 ⁴⁾	Ferraz Shawmut J
1.1	5017906-010	KLN-R-10	ATM-R-10	A2K-10-R	FWX-10	–	–	HSJ-10
1.5	5017906-016	KLN-R-15	ATM-R-15	A2K-15-R	FWX-15	–	–	HSJ-15
2.2	5017906-020	KLN-R-20	ATM-R-20	A2K-20-R	FWX-20	–	–	HSJ-20
3.0	5017906-025	KLN-R-25	ATM-R-25	A2K-25-R	FWX-25	–	–	HSJ-25
3.7	5012406-032	KLN-R-30	ATM-R-30	A2K-30-R	FWX-30	–	–	HSJ-30
5.5/7.5	5014006-050	KLN-R-50	–	A2K-50-R	FWX-50	–	–	HSJ-50
11	5014006-063	KLN-R-60	–	A2K-60-R	FWX-60	–	–	HSJ-60
15	5014006-080	KLN-R-80	–	A2K-80-R	FWX-80	–	–	HSJ-80
18.5–22	2028220-125	KLN-R-125	–	A2K-125-R	FWX-125	–	–	HSJ-125
30	2028220-150	KLN-R-150	–	A2K-150-R	FWX-150	L25S-150	A25X-150	HSJ-150
37	2028220-200	KLN-R-200	–	A2K-200-R	FWX-200	L25S-200	A25X-200	HSJ-200
45	2028220-250	KLN-R-250	–	A2K-250-R	FWX-250	L25S-250	A25X-250	HSJ-250

Table 7.13 3x200–240 V, Enclosure Types A, B, and C

- 1) KTS-fuses from Bussmann may substitute KTN for 240 V frequency converters.
- 2) FWH-fuses from Bussmann may substitute FWX for 240 V frequency converters.
- 3) A6KR fuses from Ferraz Shawmut may substitute A2KR for 240 V frequency converters.
- 4) A50X fuses from Ferraz Shawmut may substitute A25X for 240 V frequency converters.

3x380–480 V

Power [kW]	Recommended maximum fuse					
	Bussmann Type RK1	Bussmann Type J	Bussmann Type T	Bussmann Type CC	Bussmann Type CC	Bussmann Type CC
1.1	KTS-R-6	JKS-6	JJS-6	FNQ-R-6	KTK-R-6	LP-CC-6
1.5–2.2	KTS-R-10	JKS-10	JJS-10	FNQ-R-10	KTK-R-10	LP-CC-10
3	KTS-R-15	JKS-15	JJS-15	FNQ-R-15	KTK-R-15	LP-CC-15
4	KTS-R-20	JKS-20	JJS-20	FNQ-R-20	KTK-R-20	LP-CC-20
5.5	KTS-R-25	JKS-25	JJS-25	FNQ-R-25	KTK-R-25	LP-CC-25
7.5	KTS-R-30	JKS-30	JJS-30	FNQ-R-30	KTK-R-30	LP-CC-30
11–15	KTS-R-40	JKS-40	JJS-40	–	–	–
18	KTS-R-50	JKS-50	JJS-50	–	–	–
22	KTS-R-60	JKS-60	JJS-60	–	–	–
30	KTS-R-80	JKS-80	JJS-80	–	–	–
37	KTS-R-100	JKS-100	JJS-100	–	–	–
45	KTS-R-125	JKS-125	JJS-125	–	–	–
55	KTS-R-150	JKS-150	JJS-150	–	–	–
75	KTS-R-200	JKS-200	JJS-200	–	–	–
90	KTS-R-250	JKS-250	JJS-250	–	–	–

Table 7.14 3x380–480 V, Enclosure Types A, B, and C

Power [kW]	Recommended maximum fuse							
	SIBA Type RK1	Littelfuse Type RK1	Ferraz Shawmut Type CC	Ferraz Shawmut Type RK1	Bussmann JFHR2	Ferraz Shawmut J	Ferraz Shawmut JFHR2 ¹⁾	Littelfuse JFHR2
1.1	5017906-006	KLS-R-6	ATM-R-6	A6K-6-R	FWH-6	HSJ-6	–	–
1.5–2.2	5017906-010	KLS-R-10	ATM-R-10	A6K-10-R	FWH-10	HSJ-10	–	–
3	5017906-016	KLS-R-15	ATM-R-15	A6K-15-R	FWH-15	HSJ-15	–	–
4	5017906-020	KLS-R-20	ATM-R-20	A6K-20-R	FWH-20	HSJ-20	–	–
5.5	5017906-025	KLS-R-25	ATM-R-25	A6K-25-R	FWH-25	HSJ-25	–	–
7.5	5012406-032	KLS-R-30	ATM-R-30	A6K-30-R	FWH-30	HSJ-30	–	–
11–15	5014006-040	KLS-R-40	–	A6K-40-R	FWH-40	HSJ-40	–	–
18	5014006-050	KLS-R-50	–	A6K-50-R	FWH-50	HSJ-50	–	–
22	5014006-063	KLS-R-60	–	A6K-60-R	FWH-60	HSJ-60	–	–
30	2028220-100	KLS-R-80	–	A6K-80-R	FWH-80	HSJ-80	–	–
37	2028220-125	KLS-R-100	–	A6K-100-R	FWH-100	HSJ-100	–	–
45	2028220-125	KLS-R-125	–	A6K-125-R	FWH-125	HSJ-125	–	–
55	2028220-160	KLS-R-150	–	A6K-150-R	FWH-150	HSJ-150	–	–
75	2028220-200	KLS-R-200	–	A6K-200-R	FWH-200	HSJ-200	A50-P-225	L50-S-225
90	2028220-250	KLS-R-250	–	A6K-250-R	FWH-250	HSJ-250	A50-P-250	L50-S-250

Table 7.15 3x380–480 V, Enclosure Types A, B, and C

1) Ferraz Shawmut A50QS fuses may substitute A50P fuses.

3x525–600 V

Power [kW]	Recommended maximum fuse									
	Bussmann Type RK1	Bussmann Type J	Bussmann Type T	Bussmann Type CC	Bussmann Type CC	Bussmann Type CC	SIBA Type RK1	Littelfuse Type RK1	Ferraz Shawmut Type RK1	Ferraz Shawmut J
1.1	KTS-R-5	JKS-5	JJS-6	FNQ-R-5	KTK-R-5	LP-CC-5	5017906-005	KLS-R-005	A6K-5-R	HSJ-6
1.5–2.2	KTS-R-10	JKS-10	JJS-10	FNQ-R-10	KTK-R-10	LP-CC-10	5017906-010	KLS-R-010	A6K-10-R	HSJ-10
3	KTS-R-15	JKS-15	JJS-15	FNQ-R-15	KTK-R-15	LP-CC-15	5017906-016	KLS-R-015	A6K-15-R	HSJ-15
4	KTS-R-20	JKS-20	JJS-20	FNQ-R-20	KTK-R-20	LP-CC-20	5017906-020	KLS-R-020	A6K-20-R	HSJ-20
5.5	KTS-R-25	JKS-25	JJS-25	FNQ-R-25	KTK-R-25	LP-CC-25	5017906-025	KLS-R-025	A6K-25-R	HSJ-25
7.5	KTS-R-30	JKS-30	JJS-30	FNQ-R-30	KTK-R-30	LP-CC-30	5017906-030	KLS-R-030	A6K-30-R	HSJ-30
11–15	KTS-R-35	JKS-35	JJS-35	–	–	–	5014006-040	KLS-R-035	A6K-35-R	HSJ-35
18	KTS-R-45	JKS-45	JJS-45	–	–	–	5014006-050	KLS-R-045	A6K-45-R	HSJ-45
22	KTS-R-50	JKS-50	JJS-50	–	–	–	5014006-050	KLS-R-050	A6K-50-R	HSJ-50
30	KTS-R-60	JKS-60	JJS-60	–	–	–	5014006-063	KLS-R-060	A6K-60-R	HSJ-60
37	KTS-R-80	JKS-80	JJS-80	–	–	–	5014006-080	KLS-R-075	A6K-80-R	HSJ-80
45	KTS-R-100	JKS-100	JJS-100	–	–	–	5014006-100	KLS-R-100	A6K-100-R	HSJ-100
55	KTS-R-125	JKS-125	JJS-125	–	–	–	2028220-125	KLS-125	A6K-125-R	HSJ-125
75	KTS-R-150	JKS-150	JJS-150	–	–	–	2028220-150	KLS-150	A6K-150-R	HSJ-150
90	KTS-R-175	JKS-175	JJS-175	–	–	–	2028220-200	KLS-175	A6K-175-R	HSJ-175



Table 7.16 3x525–600 V, Enclosure Types A, B, and C

7.9 Power Ratings, Weight, and Dimensions

Enclosure Type [kW]:	A2	A3	A4	A5	B1	B2	B3	B4	C1	C2	C3	C4
200-240 V	1.1-2.2	3.0-3.7	1.1-2.2	1.1-3.7	5.5-11	15	5.5-11	15-18.5	18.5-30	37-45	22-30	37-45
380-480 V	1.1-4.0	5.5-7.5	1.1-4.0	1.1-7.5	11-18.5	22-30	11-18.5	22-37	37-55	75-90	45-55	75-90
525-600 V	1.1-7.5	1.1-7.5	1.1-7.5	1.1-7.5	11-18.5	11-30	11-18.5	22-37	37-55	37-90	45-55	75-90
IP	20	20	55/66	55/66	21/55/66	21/55/66	20	20	21/55/66	21/55/66	20	20
NEMA	Chassis Type 1	Chassis Type 1	Type 12/4X	Type 12/4X	Type 1/12/4X	Type 1/12/4X	Chassis	Chassis	Type 1/12/4X	Type 1/12/4X	Chassis	Chassis
Height [mm]												
Enclosure	A ¹⁾ 246	246	372	390	480	650	350	460	680	770	490	600
Height of backplate	A 268	268	375	390	480	650	399	520	680	770	550	660
Height with de-coupling plate for Fieldbus cables	A 374	374	-	-	-	-	419	595	-	-	630	800
Distance between mounting holes	a 257	257	350	401	454	624	380	495	648	739	521	631
Width [mm]												
Enclosure	B 90	130	130	200	242	242	165	231	308	370	308	370
Width of backplate	B 90	130	130	200	242	242	165	231	308	370	308	370
Width of backplate with 1 C option	B 130	170	170	-	242	242	205	231	308	370	308	370
Distance between mounting holes	b 70	110	110	171	210	210	140	200	272	334	270	330
Depth²⁾ [mm]												
Without option A/B	C 205	205	205	175	260	260	248	242	310	335	333	333
With option A/B	C 220	220	220	175	260	260	262	242	310	335	333	333
Screw holes [mm]												
c	8.0	8.0	8.0	8.2	12	12	8	-	12	12	-	-
d	11	11	11	12	19	19	12	-	19	19	-	-
e	5.5	5.5	5.5	6.5	9	9	6.8	8.5	9.0	9.0	8.5	8.5
f	9	9	9	6	9	9	7.9	15	9.8	9.8	17	17
Maximum weight [kg]												
	4.9	5.3	6.6	9.7	14	23	12	23.5	45	65	35	50

¹⁾ See Illustration 7.2 and Illustration 7.3 for top and bottom mounting holes.

²⁾ Depth of enclosure varies with different options installed.

Table 7.17 Power Ratings, Weight, and Dimensions

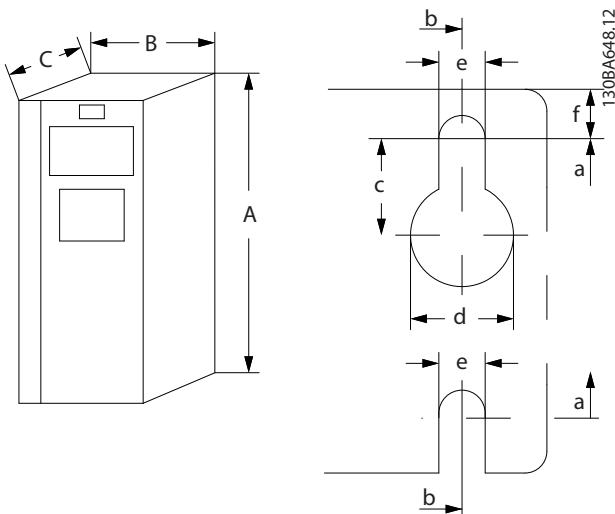

Illustration 7.2 Top and Bottom Mounting Holes (See chapter 7.9 Power Ratings, Weight, and Dimensions)

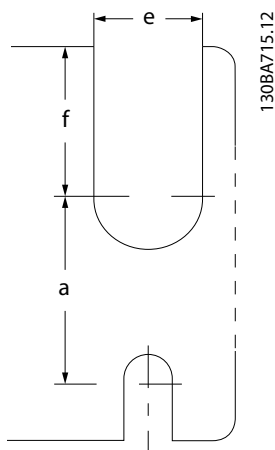

Illustration 7.3 Top and Bottom Mounting Holes (B4, C3, and C4)

7.10 dU/dt Testing

To avoid damage to motors without phase insulation paper or other insulation reinforcement designed for operation of the frequency converter, install a dU/dt filter or LC filter on the output of the frequency converter.

When a transistor in the inverter bridge switches, the voltage across the motor increases by a dU/dt ratio depending on:

- Motor inductance.
- Motor cable (type, cross-section, length, screened, or unscreened).

The natural induction causes an overshoot voltage peak in the motor voltage before it stabilises. The level depends on the voltage in the DC-link.

Switching of the IGBTs causes peak voltage on the motor terminals. The rise time and the peak voltage affect the

service life of the motor. If the peak voltage is too high, motors without phase coil insulation can be adversely affected over time.

With short motor cables (a few metres), the rise time, and peak voltage are lower. The rise time and peak voltage increase with cable length.

The frequency converter complies with IEC 60034-25 and IEC 60034-17 for motor design.

To obtain approximate values for cable lengths and voltages not mentioned in the following, use the following:

- Rise time increases/decreases proportionally with cable length.
- $U_{PEAK} = DC\text{-link voltage} \times 1.9$
(DC-link voltage = Mains voltage $\times 1.35$).
- $dU/dt = \frac{0.8 \times U_{PEAK}}{Risetime}$

Data is measured according to IEC 60034-17. Cable lengths are in metres.

200–240 V (T2)

Cable length [m]	Mains voltage [V]	Rise time [µsec]	U_{PEAK} [kV]	dU/dt [kV/µsec]
36	240	0.226	0.616	2.142
50	240	0.262	0.626	1.908
100	240	0.650	0.614	0.757
150	240	0.745	0.612	0.655

Table 7.18 Frequency Converter, P5K5, T2

Cable length [m]	Mains voltage [V]	Rise time [µsec]	U_{PEAK} [kV]	dU/dt [kV/µsec]
5	230	0.13	0.510	3.090
50	230	0.23	0.590	2.034
100	230	0.54	0.580	0.865
150	230	0.66	0.560	0.674

Table 7.19 Frequency Converter, P7K5, T2

Cable length [m]	Mains voltage [V]	Rise time [µsec]	U_{PEAK} [kV]	dU/dt [kV/µsec]
36	240	0.264	0.624	1.894
136	240	0.536	0.596	0.896
150	240	0.568	0.568	0.806

Table 7.20 Frequency Converter, P11K, T2

Cable length [m]	Mains voltage [V]	Rise time [μsec]	U _{PEAK} [kV]	dU/dt [kV/μsec]
30	240	0.556	0.650	0.935
100	240	0.592	0.594	0.807
150	240	0.708	0.575	0.669

Table 7.21 Frequency Converter, P15K, T2

Cable length [m]	Mains voltage [V]	Rise time [μsec]	U _{PEAK} [kV]	dU/dt [kV/μsec]
36	240	0.244	0.608	1.993
136	240	0.568	0.580	0.832
150	240	0.720	0.574	0.661

Table 7.22 Frequency Converter, P18K, T2

Cable length [m]	Mains voltage [V]	Rise time [μsec]	U _{PEAK} [kV]	dU/dt [kV/μsec]
36	240	0.244	0.608	1.993
136	240	0.560	0.580	0.832
150	240	0.720	0.574	0.661

Table 7.23 Frequency Converter, P22K, T2

Cable length [m]	Mains voltage [V]	Rise time [μsec]	U _{PEAK} [kV]	dU/dt [kV/μsec]
15	240	0.194	0.626	2.581
50	240	0.252	0.574	1.929
150	240	0.444	0.538	0.977

Table 7.24 Frequency Converter, P30K, T2

Cable length [m]	Mains voltage [V]	Rise time [μsec]	U _{PEAK} [kV]	dU/dt [kV/μsec]
30	240	0.300	0.598	1.593
100	240	0.536	0.566	0.843
150	240	0.776	0.546	0.559

Table 7.25 Frequency Converter, P37K, T2

Cable length [m]	Mains voltage [V]	Rise time [μsec]	U _{PEAK} [kV]	dU/dt [kV/μsec]
30	240	0.300	0.598	1.593
100	240	0.536	0.566	0.843
150	240	0.776	0.546	0.559

Table 7.26 Frequency Converter, P45K, T2

380–480 V (T4)

Cable length [m]	Mains voltage [V]	Rise time [μsec]	U _{PEAK} [kV]	dU/dt [kV/μsec]
5	400	0.640	0.690	0.862
50	400	0.470	0.985	0.985
150	400	0.760	1.045	0.947

Table 7.27 Frequency Converter, P1K5, T4

Cable length [m]	Mains voltage [V]	Rise time [μsec]	U _{PEAK} [kV]	dU/dt [kV/μsec]
5	400	0.172	0.890	4.156
50	400	0.310	–	2.564
150	400	0.370	1.190	1.770

Table 7.28 Frequency Converter, P4K0, T4

Cable length [m]	Mains voltage [V]	Rise time [μsec]	U _{PEAK} [kV]	dU/dt [kV/μsec]
5	400	0.04755	0.739	8.035
50	400	0.207	1.040	4.548
150	400	0.6742	1.030	2.828

Table 7.29 Frequency Converter, P7K5, T4

Cable length [m]	Mains voltage [V]	Rise time [μsec]	U _{PEAK} [kV]	dU/dt [kV/μsec]
15	400	0.408	0.718	1.402
100	400	0.364	1.050	2.376
150	400	0.400	0.980	2.000

Table 7.30 Frequency Converter, P11K, T4

Cable length [m]	Mains voltage [V]	Rise time [μsec]	U _{PEAK} [kV]	dU/dt [kV/μsec]
36	400	0.422	1.060	2.014
100	400	0.464	0.900	1.616
150	400	0.896	1.000	0.915

Table 7.31 Frequency Converter, P15K, T4

Cable length [m]	Mains voltage [V]	Rise time [μsec]	U _{PEAK} [kV]	dU/dt [kV/μsec]
36	400	0.344	1.040	2.442
100	400	1.000	1.190	0.950
150	400	1.400	1.040	0.596

Table 7.32 Frequency Converter, P18K, T4

Cable length [m]	Mains voltage [V]	Rise time [µsec]	U _{PEAK} [kV]	dU/dt [kV/µsec]
36	400	0.232	0.950	3.534
100	400	0.410	0.980	1.927
150	400	0.430	0.970	1.860

Table 7.33 Frequency Converter, P22K, T4

Cable length [m]	Mains voltage [V]	Rise time [µsec]	U _{PEAK} [kV]	dU/dt [kV/µsec]
15	400	0.271	1.000	3.100
100	400	0.440	1.000	1.818
150	400	0.520	0.990	1.510

Table 7.34 Frequency Converter, P30K, T4

Cable length [m]	Mains voltage [V]	Rise time [µsec]	U _{PEAK} [kV]	dU/dt [kV/µsec]
5	480	0.270	1.276	3.781
50	480	0.435	1.184	2.177
100	480	0.840	1.188	1.131
150	480	0.940	1.212	1.031

Table 7.35 Frequency Converter, P37K, T4

Cable length [m]	Mains voltage [V]	Rise time [µsec]	U _{PEAK} [kV]	dU/dt [kV/µsec]
36	400	0.254	1.056	3.326
50	400	0.465	1.048	1.803
100	400	0.815	1.032	1.013
150	400	0.890	1.016	0.913

Table 7.36 Frequency Converter, P45K, T4

Cable length [m]	Mains voltage [V]	Rise time [µsec]	U _{PEAK} [kV]	dU/dt [kV/µsec]
10	400	0.350	0.932	2.130

Table 7.37 Frequency Converter, P55K, T4

Cable length [m]	Mains voltage [V]	Rise time [µsec]	U _{PEAK} [kV]	dU/dt [kV/µsec]
5	480	0.371	1.170	2.466

Table 7.38 Frequency Converter, P75K, T4

Cable length [m]	Mains voltage [V]	Rise time [µsec]	U _{PEAK} [kV]	dU/dt [kV/µsec]
5	400	0.364	1.030	2.264

Table 7.39 Frequency Converter, P90K, T4

7.11 Acoustic Noise Ratings

The typical values measured at a distance of 1 m from the unit:

Enclosure size	At reduced fan speed (50%) [dBA]	Full fan speed [dBA]
A2	51	60
A3	51	60
A4	50	55
A5	54	63
B1	61	67
B2	58	70
B3	59.4	70.5
B4	53	62.8
C1	52	62
C2	55	65
C3	56.4	67.3
C4	-	-

Table 7.40 Measured Values

7.12 Selected Options

7.12.1 VLT® General Purpose I/O Module MCB 101

MCB 101 is used for extension of digital and analog inputs and outputs.

Fit the MCB 101 into slot B of the frequency converter.

Contents:

- MCB 101 option module
- Extended fixture for LCP
- Terminal cover

MCB 101 FC Series
 General Purpose I/O B slot
 SW. ver. XX.XX Code No. 130BXXXX

130BA208.10

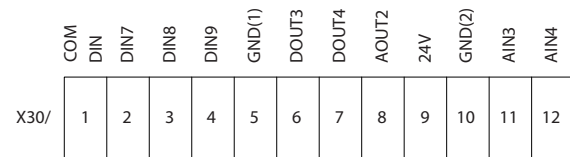

Illustration 7.4 MCB 101 Option

7.12.2 VLT® Relay Card MCB 105

The MCB 105 includes 3 pieces of SPDT contacts and fits into option slot B.

Electrical Data

Maximum terminal load (AC-1) ¹⁾ (resistive load)	240 V AC 2 A
Maximum terminal load (AC-15) ¹⁾ (inductive load @ COSφ 0.4)	240 V AC 0.2 A
Maximum terminal load (DC-1) ¹⁾ (resistive load)	24 V DC 1 A
Maximum terminal load (DC-13) ¹⁾ (inductive load)	24 V DC 0.1 A
Minimum terminal load (DC)	5 V 10 mA
Maximum switching rate at rated load/min load	6 minimum ⁻¹ /20 s ⁻¹

1) IEC 947 part 4 and 5

When the relay option kit is ordered separately, the kit includes:

- Relay module MCB 105.
- Enlarged LCP fixture and enlarged terminal cover.
- Label for covering access to switches S201, S202, and S801.
- Cable strips for fastening cables to relay module.

7

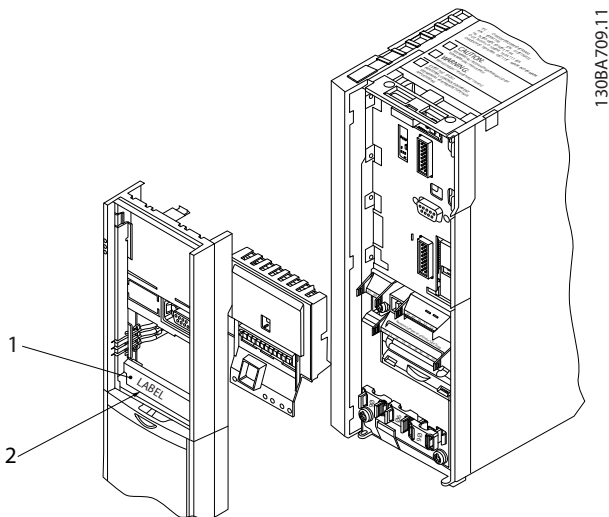

1	WARNING! The label MUST be placed on the LCP frame as shown (UL approved).
2	Relay card

Illustration 7.5 Enclosure Sizes A2, A3, and B3

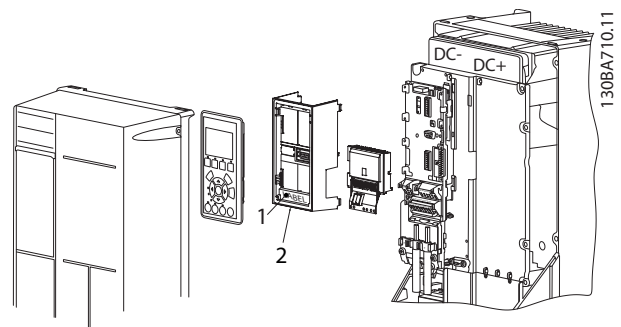

1	WARNING! The label MUST be placed on the LCP frame as shown (UL approved).
2	Relay card

Illustration 7.6 Enclosure Sizes A5, B1, B2, B4, C1, C2, C3, and C4



Illustration 7.7 Warning Label Placed on Option

How to add the MCB 105:

1. Disconnect power to the frequency converter.
2. Disconnect power to the live part connections on relay terminals.
3. Remove the LCP, the terminal cover, and the LCP fixture from the frequency converter.
4. Fit the MCB 105 in slot B.
5. Connect the control cables and fasten the cables with the enclosed cable strips.
6. Make sure that the length of the stripped wire is correct (see *Illustration 7.9*).
7. Do not mix live parts (high voltage) with control signals (PELV).
8. Fit the enlarged LCP fixture and enlarged terminal cover.

9. Replace the LCP.
10. Connect power to the frequency converter.
11. Select the relay functions in *parameter 5-40 Function Relay [6-8]*, *parameter 5-41 On Delay, Relay[6-8]*, and *parameter 5-42 Off Delay, Relay [6-8]*.

NOTICE

Array [6] is relay 7, array [7] is relay 8, and array [8] is relay 9

NOTICE

To access RS485 termination switch S801, or current/voltage switches S201/S202, dismount the relay card (see *Illustration 7.5* and *Illustration 7.6*, position 2).

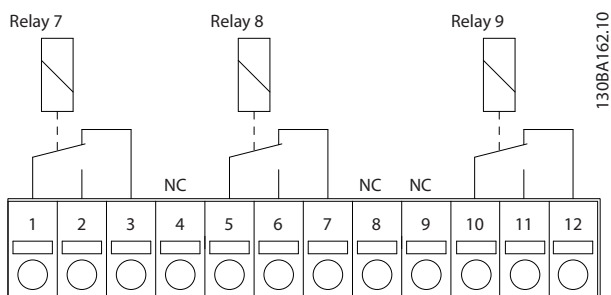

Illustration 7.8 Relays

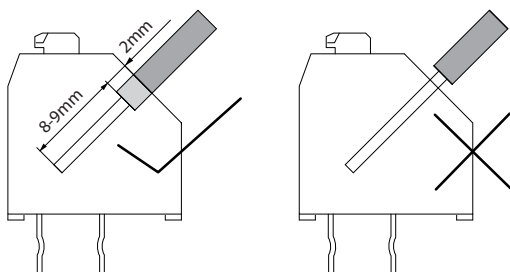
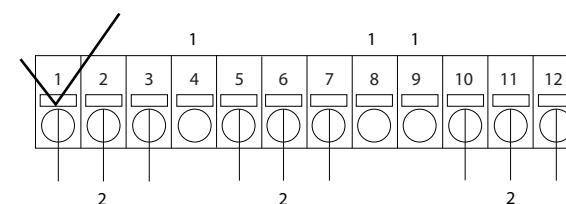
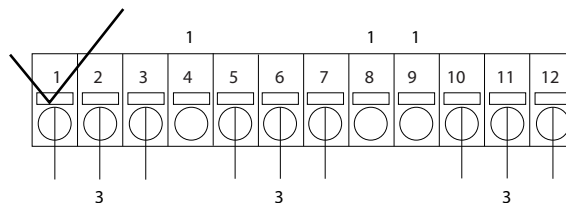
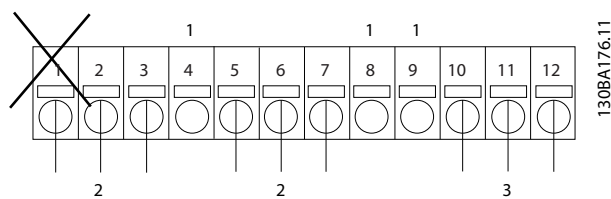

Illustration 7.9 Correct Wire Inserting



1	NC
2	Live part
3	PELV

Illustration 7.10 Correct Relay Wiring

NOTICE

Do not combine 24/48 V systems with high-voltage systems.

7.12.3 VLT® Extended Relay Card MCB 113

The MCB 113 extends the I/O of the frequency converter with:

- 7 digital inputs.
- 2 analog outputs.
- 4 SPDT relays.

The extended I/O increases flexibility and enables compliance with the German NAMUR NE37 recommendations.

The MCB 113 is a standard C1 option and is automatically detected after mounting.

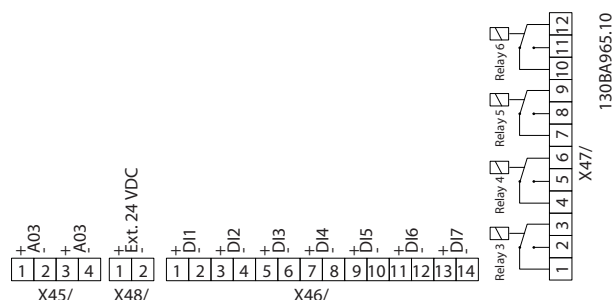

Illustration 7.11 Electrical Connections of MCB 113

To ensure galvanic isolation between the frequency converter and the option card, connect the MCB 113 to an

external 24 V on X48. When galvanic isolation is not required, the option card can be supplied through internal 24 V from the frequency converter.

NOTICE

To connect both 24 V signals and high-voltage signals in the relays, ensure that there is one unused relay between the 24 V signal and the high-voltage signal.

To set up the MCB 113, use parameter groups:

- 5-1* Digital Input.
- 6-7* Analog Output 3.
- 6-8* Analog Output 4.
- 14-8* Options.
- 5-4* Relays.
- 16-6* Inputs and outputs.

NOTICE

In parameter group 5-4* Relay,

- Array [2] is relay 3.
- Array [3] is relay 4.
- Array [4] is relay 5.
- Array [5] is relay 6.

Electrical Data

Relays

Numbers	4 SPDT
Load at 250 V AC/30 V DC	8 A
Load at 250 V AC/30 V DC with COSφ = 0.4	3.5 A
Oversvoltage category (contact-earth)	III
Oversvoltage category (contact-contact)	II
Combination of 250 V and 24 V signals	Possible with one unused relay between
Maximum throughput delay	10 ms
Isolated from ground/chassis for use on IT mains systems	

Digital Inputs

Numbers	7
Range	0–24 V
Mode	PNP/NPN
Input impedance	4 kW
Low trigger level	6.4 V
High trigger level	17 V
Maximum throughput delay	10 ms

Analog outputs

Numbers	2
Range	0/4 -20 mA
Resolution	11 bit
Linearity	<0.2%

7.12.4 VLT® LonWorks for ADAP-KOOL® MCA 107

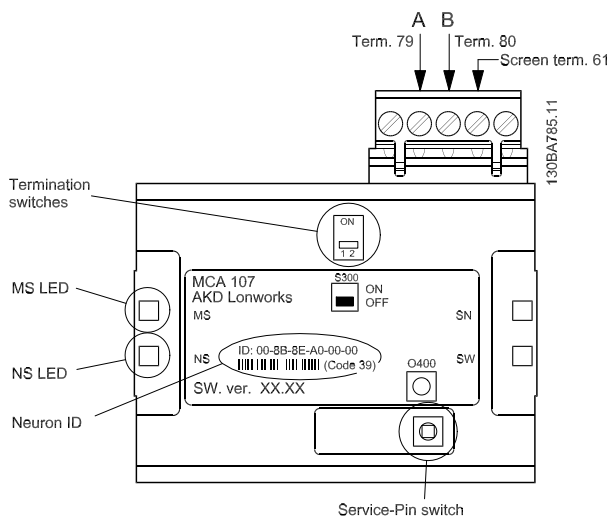

Illustration 7.12 The AKD LonWorks Option

7

S300 switches between:

- OFF: No termination (factory setting)
- ON: Single termination (120 Ω)

The push-button switch O400 activates the Service-Pin function.

LED label	Description
MS	Service LED (red)
NS	Status LED (green)

Table 7.41 LEDs

The neuron ID is printed on the option in text and in barcode (code 39).

8 Appendix - Selected Drawings

8.1 Mains Connection Drawings

This collection of drawings is intended to aid planning for access in the design phase.

Refer to the *operating instructions* for installation procedures including:

- Safety requirements.
- Step-by-step installation procedures.
- Alternative configurations.
- Extra drawings.

Mains connection for enclosure sizes A2 and A3

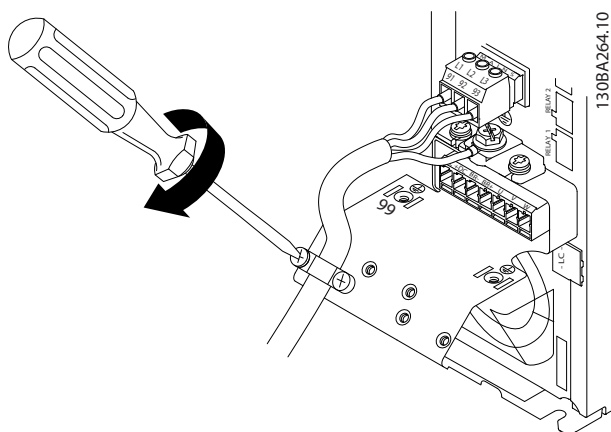

Illustration 8.1 Support Bracket

Mains connection for enclosure sizes A4/A5

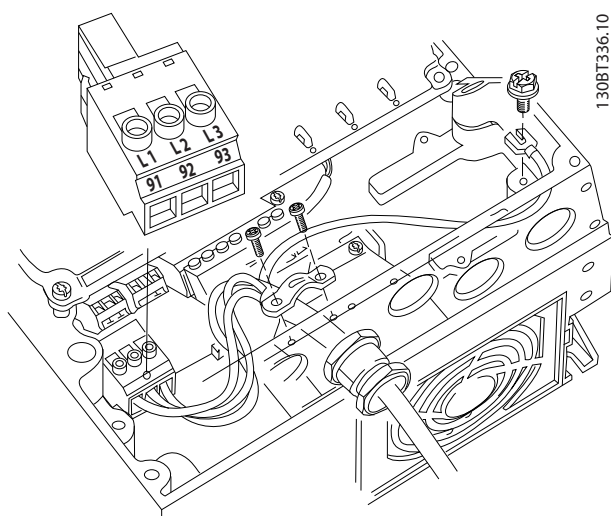

Illustration 8.2 Mains and Grounding without Disconnecter

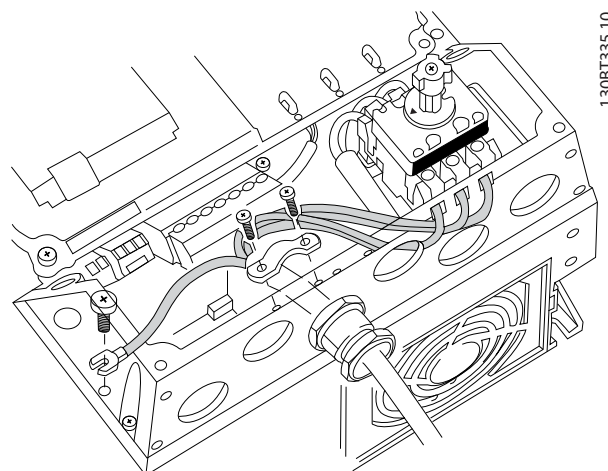

Illustration 8.3 Mains and Grounding with Disconnecter

When a disconnecter is used (enclosure sizes A4/A5), mount the PE on the left side of the frequency converter.

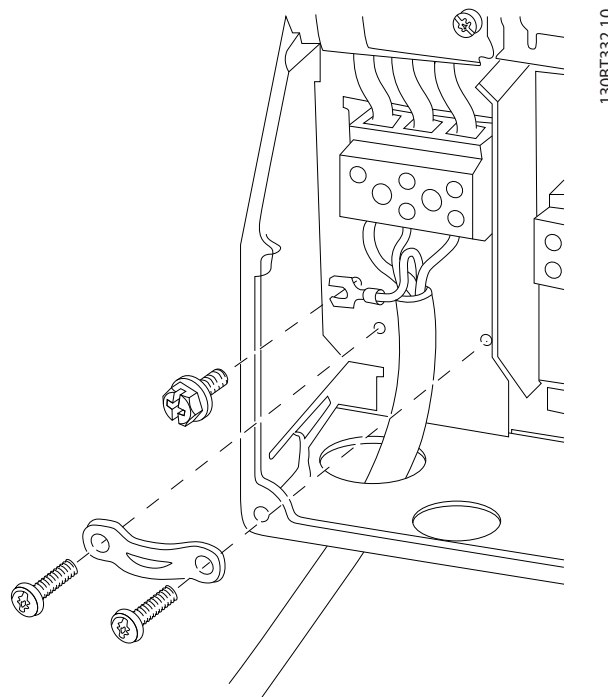

Illustration 8.4 Mains Connection Enclosures Sizes B1 and B2

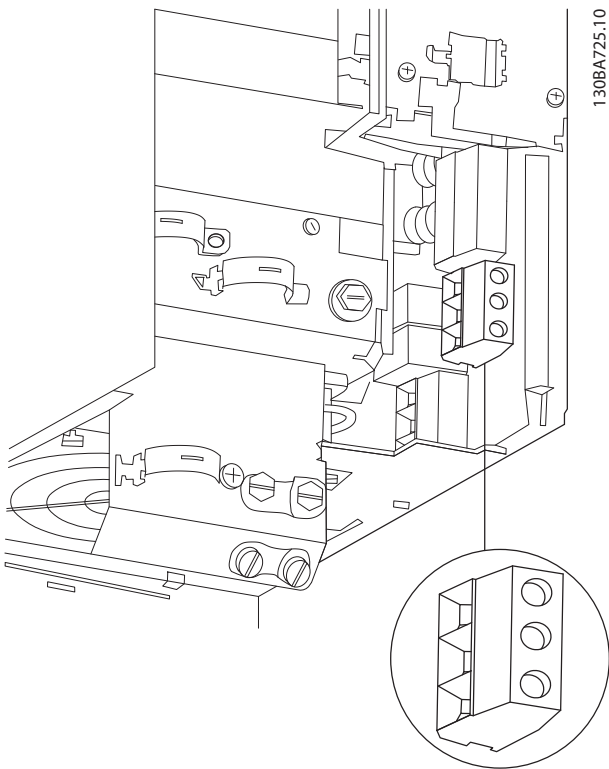

Illustration 8.5 Mains Connection Enclosure Size B3

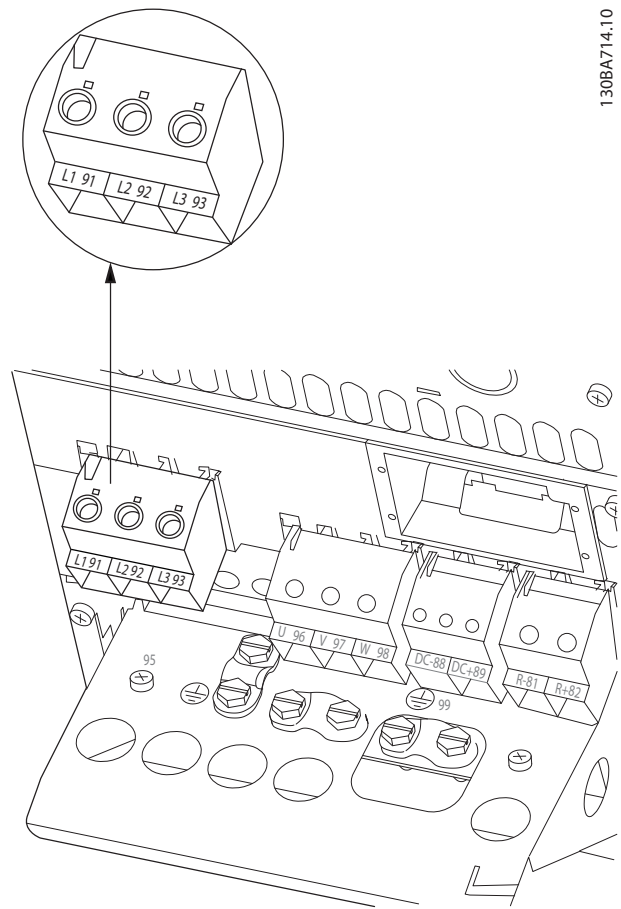

Illustration 8.6 Mains Connection Enclosure Size B4

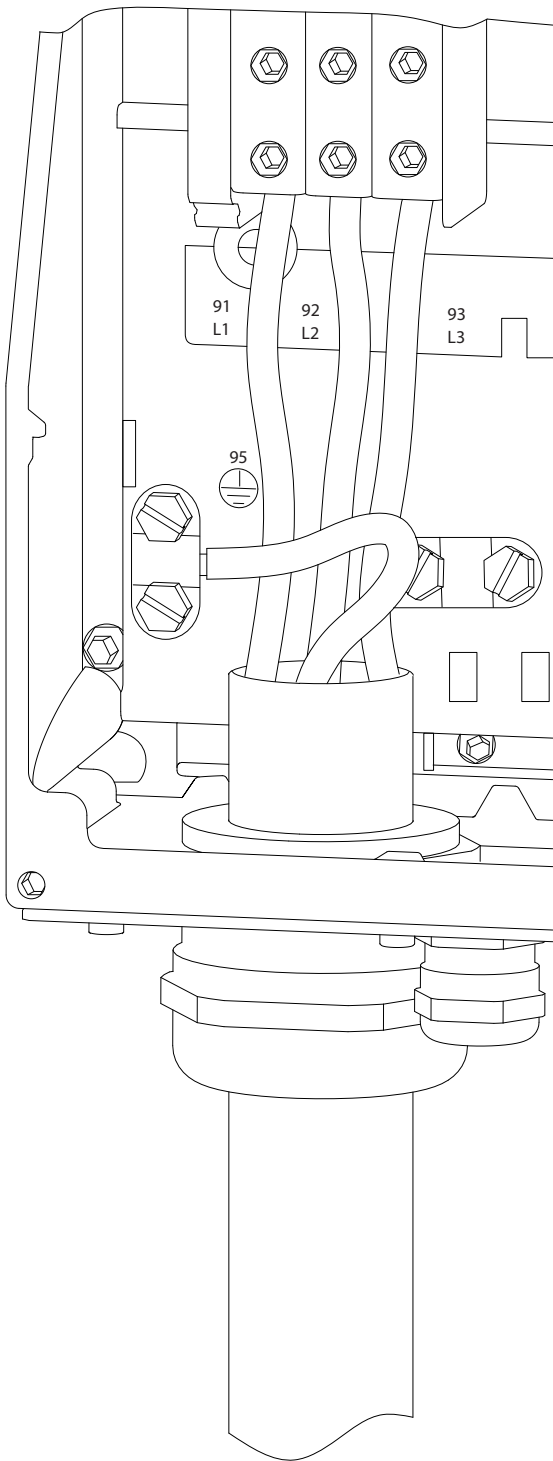
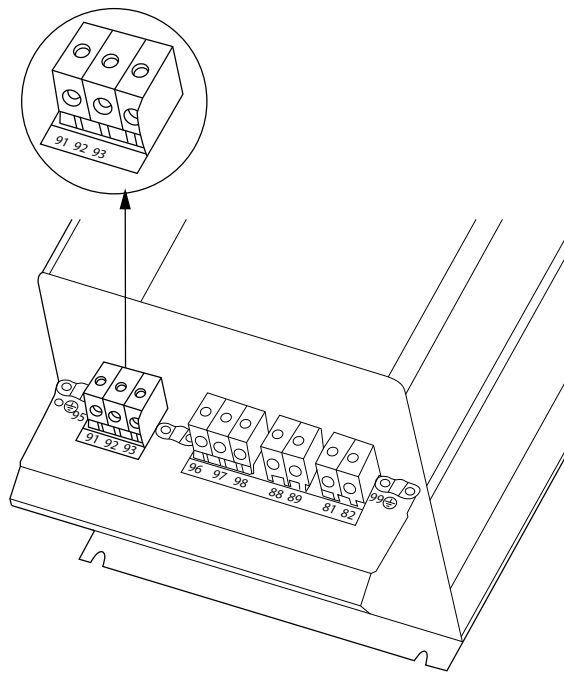

Illustration 8.7 Mains Connection Enclosure Sizes C1 and C2 (IP21/NEMA Type 1 and IP55/66/NEMA Type 12)

130BA389:10



130BA718:10

Illustration 8.8 Mains Connection Enclosure Size C3 (IP20)

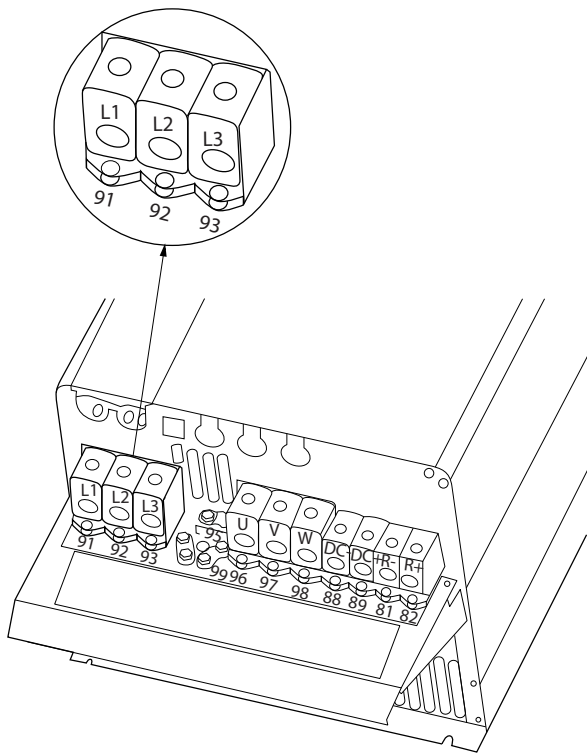

Illustration 8.9 Mains Connection Enclosure Size C4 (IP20)

130BA719.10

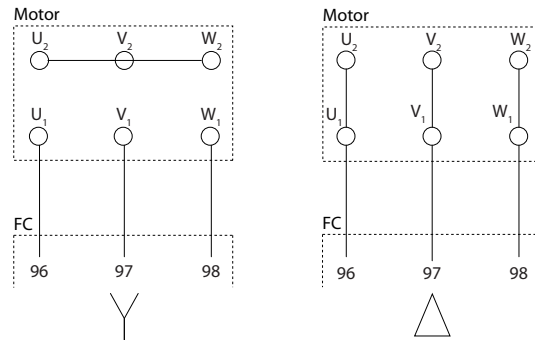

Illustration 8.10 Star and Delta Connections

175ZA114.11

All types of 3-phase asynchronous standard motors can be connected to the frequency converter. Normally, small motors are star-connected (230/400 V, Y). Large motors are normally delta-connected (400/690 V, Δ). Refer to the motor nameplate for correct connection mode and voltage.

8.2 Motor Connection Drawings

Motor connection

This collection of drawings is intended to aid planning for access in the design phase.

Refer to the *operating instructions* for installation procedures including:

- Safety requirements.
- Step-by-step installation procedures.
- Terminal descriptions.
- Alternative configurations.
- Extra drawings.

Terminal number	96	97	98	99	
	U	V	W	PE ¹⁾	Motor voltage 0–100% of mains voltage. 3 wires out of motor.
	U1	V1	W1		Delta-connected.
	W 2	U2	V2	PE ¹⁾	6 wires out of the motor.
	U1	V1	W1	PE ¹⁾	Star-connected U2, V2, W2. U2, V2, and W2 to be interconnected separately.

Table 8.1 Terminal Descriptions

1) Protective earth connection

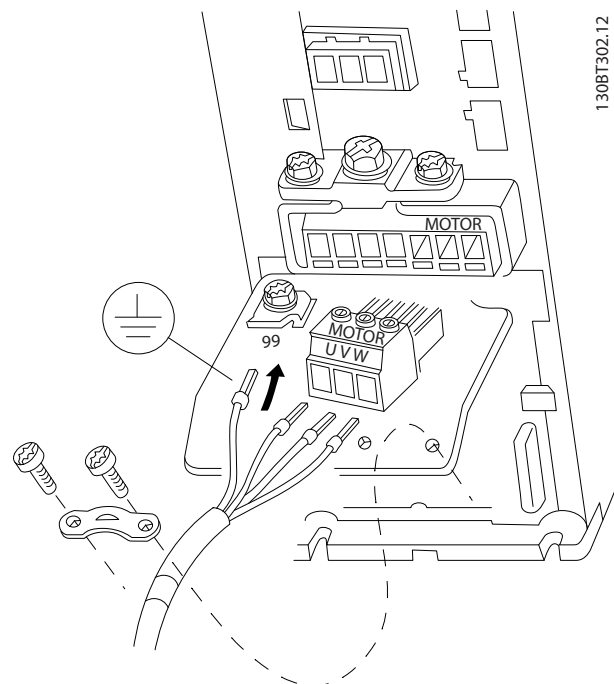
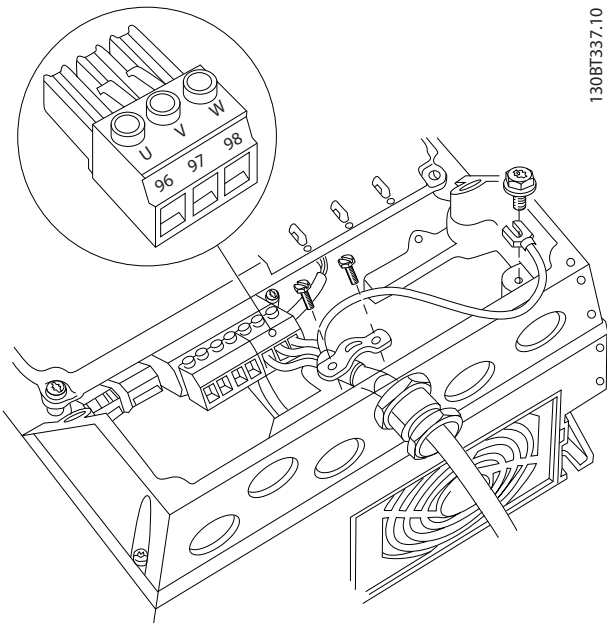

Illustration 8.11 Motor Connection for Enclosure Sizes A2 and A3

130BT302.12



130BT337.10

Illustration 8.12 Motor Connection for Enclosure Sizes A4/A5

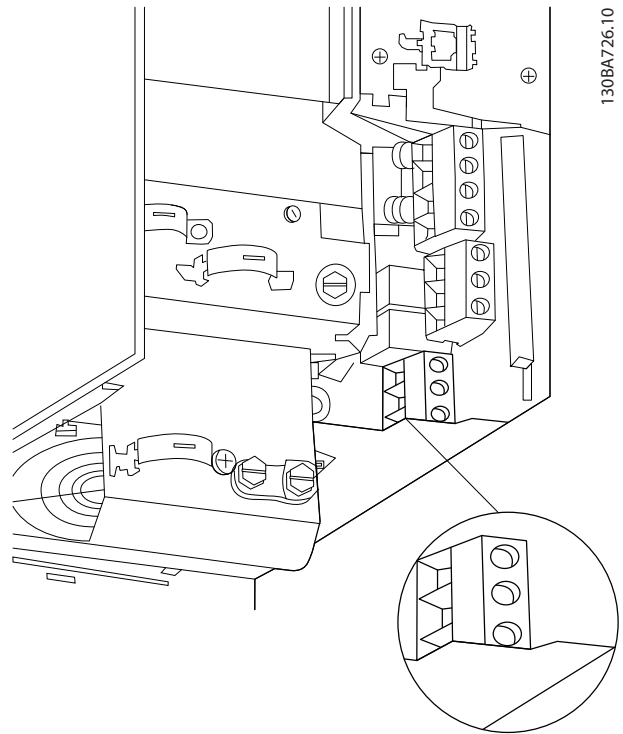

130BA726.10

Illustration 8.14 Motor Connection for Enclosure Size B3

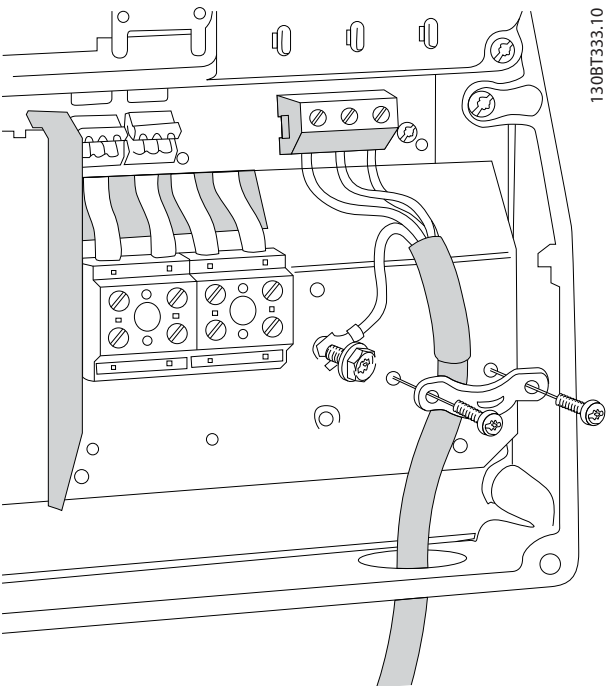

130BT333.10

Illustration 8.13 Motor Connection for Enclosure Sizes B1 and B2

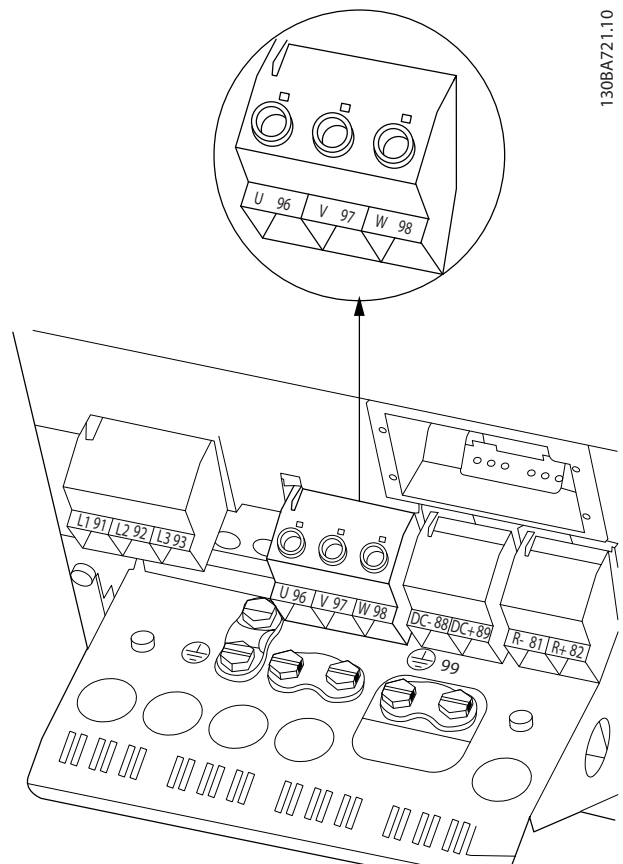

130BA721.10

Illustration 8.15 Motor Connection for Enclosure Size B4

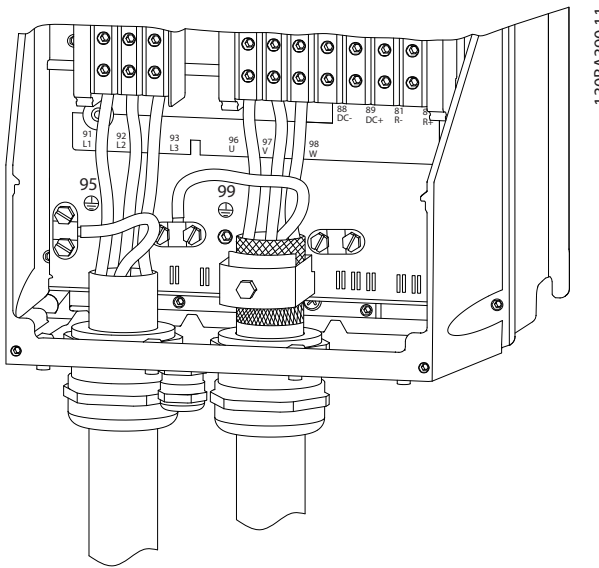

130BA390.11

Illustration 8.16 Motor Connection Enclosure Sizes C1 and C2 (IP21/NEMA Type 1 and IP55/66/NEMA Type 12)

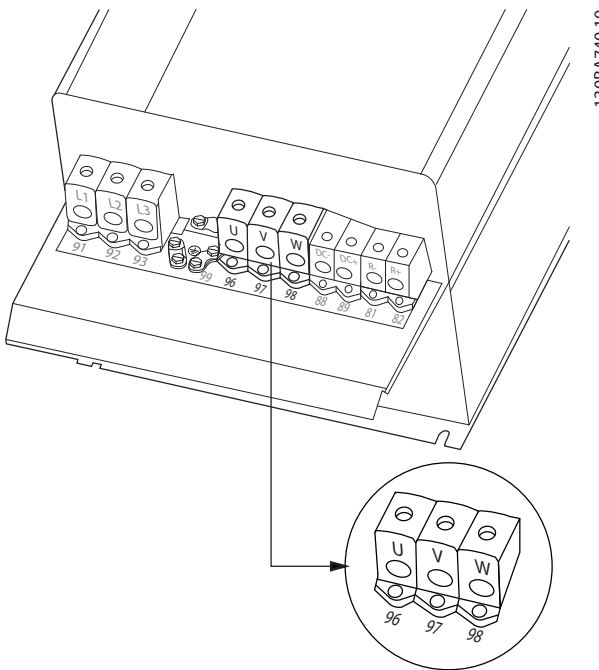

130BA740.10

Illustration 8.17 Motor Connection for Enclosure Sizes C3 and C4

8.3 Relay Terminal Drawings

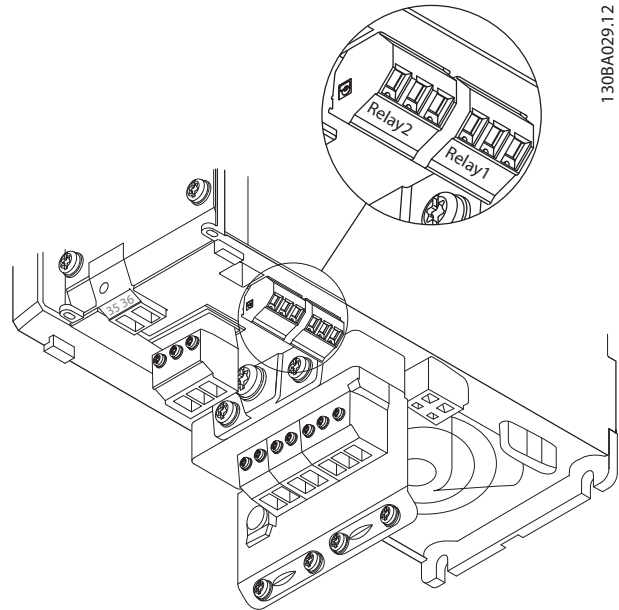

130BA029.12

Illustration 8.18 Terminals for Relay Connection (Enclosure Sizes A2 and A3).

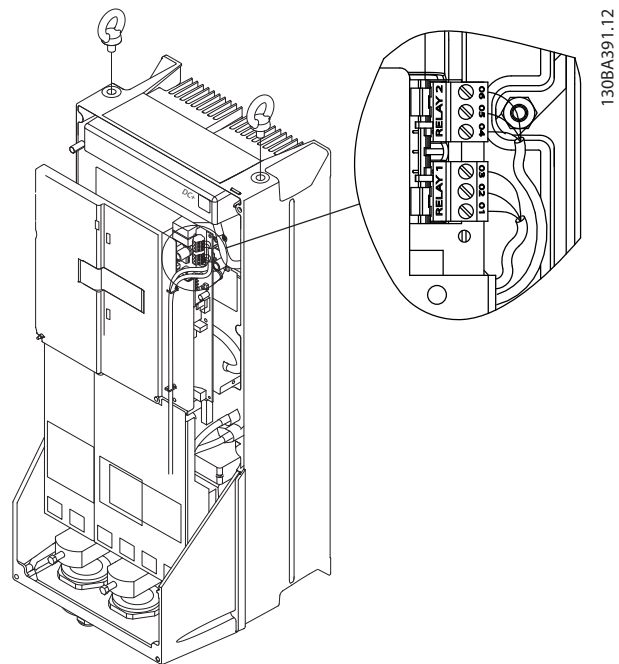

130BA391.12

Illustration 8.19 Terminals for Relay Connection (Enclosure Sizes C1 and C2).

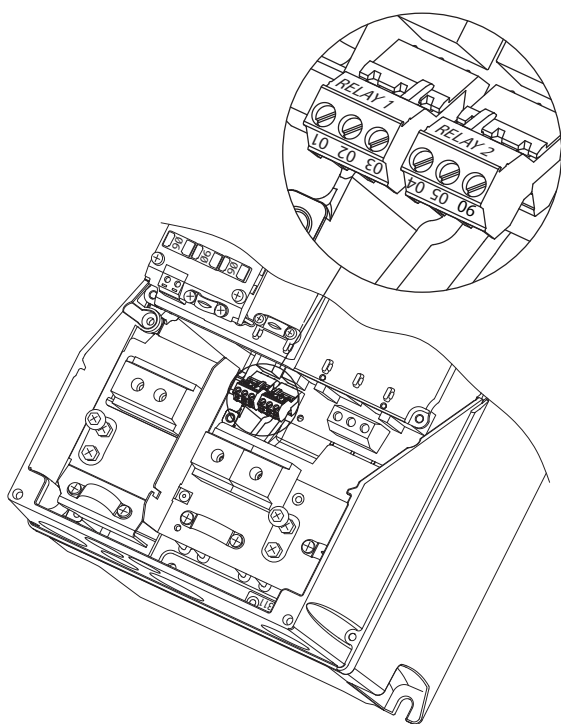

130BA215.10

8.4 Cable Entry Holes

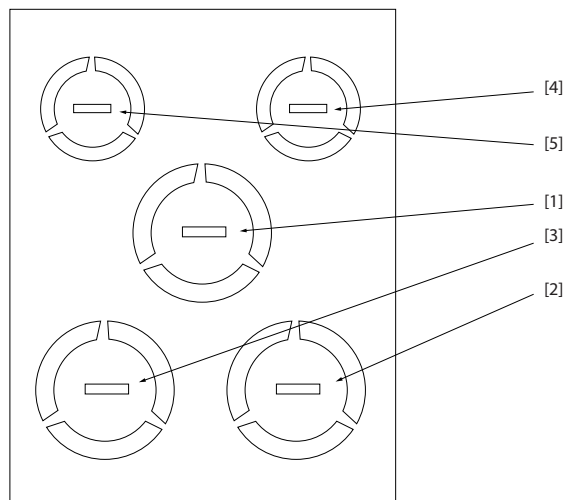

130BB656.10

8

Illustration 8.20 Terminals for Relay Connection (Enclosure Sizes A5, B1 and B2).

Hole number and recommended use	Dimensions ¹⁾		Nearest metric
	UL [in]	[mm]	
1 Mains	3/4	28.4	M25
2 Motor	3/4	28.4	M25
3 Brake/load sharing	3/4	28.4	M25
4 Control cable	1/2	22.5	M20
5 Control cable	1/2	22.5	M20

1) Tolerance ± 0.2 mm

Illustration 8.21 Enclosure Size A2, IP21

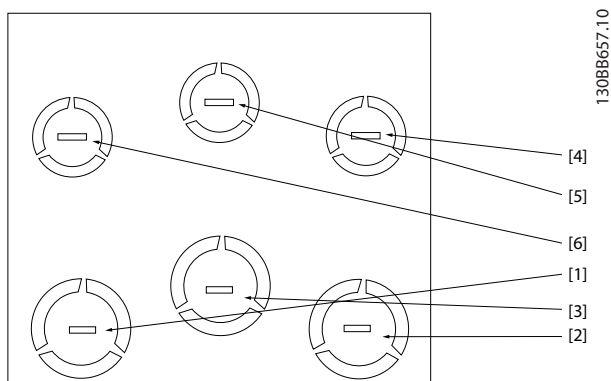

Hole number and recommended use	Dimensions ¹⁾		Nearest metric
	UL [in]	[mm]	
1 Mains	3/4	28.4	M25
2 Motor	3/4	28.4	M25
3 Brake/load sharing	3/4	28.4	M25
4 Control cable	1/2	22.5	M20
5 Control cable	1/2	22.5	M20
6 Control cable	1/2	22.5	M20

1) Tolerance ±0.2 mm

Illustration 8.22 Enclosure Size A3, IP21

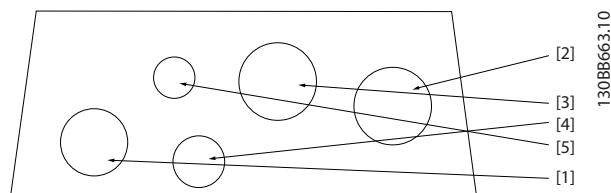

Hole number and recommended use	Dimensions ¹⁾		Nearest metric
	UL [in]	[mm]	
1 Mains	3/4	28.4	M25
2 Motor	3/4	28.4	M25
3 Brake/load sharing	3/4	28.4	M25
4 Control cable	1/2	22.5	M20
5 Removed	-	-	-

1) Tolerance ±0.2 mm

Illustration 8.23 Enclosure Size A4, IP55

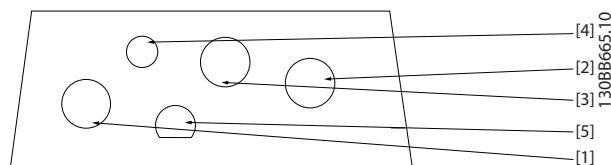

Hole number and recommended use	Nearest metric
1 Mains	M25
2 Motor	M25
3 Brake/load sharing	M25
4 Control cable	M16
5 Control cable	M20

Illustration 8.24 Enclosure Size A4, IP55 Threaded Gland Holes

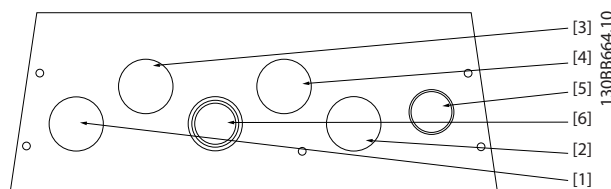

Hole number and recommended use	Dimensions ¹⁾		Nearest metric
	UL [in]	[mm]	
1 Mains	3/4	28.4	M25
2 Motor	3/4	28.4	M25
3 Brake/load sharing	3/4	28.4	M25
4 Control cable	3/4	28.4	M25
5 Control cable ²⁾	3/4	28.4	M25
6 Control cable ²⁾	3/4	28.4	M25

1) Tolerance ±0.2 mm
2) Knock-out hole

Illustration 8.25 Enclosure Size A5, IP55

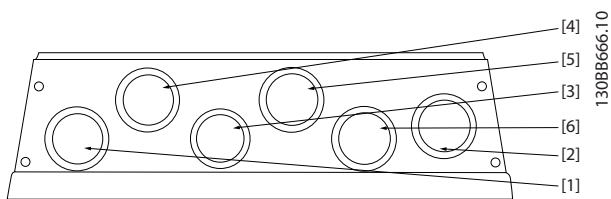

Hole number and recommended use	Nearest metric
1 Mains	M25
2 Motor	M25
3 Brake/load sharing	28.4 mm ¹⁾
4 Control cable	M25
5 Control cable	M25
6 Control cable	M25
1) Knock-out hole	

Illustration 8.26 Enclosure Size A5, IP55 Threaded Gland Holes

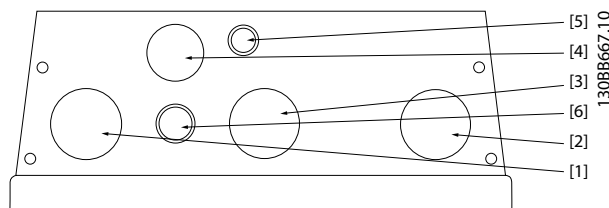

Hole number and recommended use	Dimensions ¹⁾		Nearest metric
	UL [in]	[mm]	
1 Mains	1	34.7	M32
2 Motor	1	34.7	M32
3 Brake/load sharing	1	34.7	M32
4 Control cable	3/4	28.4	M25
5 Control cable	1/2	22.5	M20
5 Control cable ²⁾	1/2	22.5	M20
1) Tolerance ±0.2 mm			
2) Knock-out hole			

Illustration 8.28 Enclosure Size B1, IP55

8

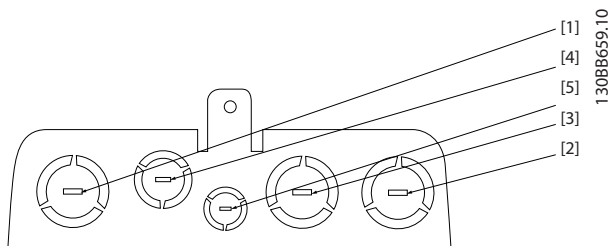

Hole number and recommended use	Dimensions ¹⁾		Nearest metric
	UL [in]	[mm]	
1 Mains	1	34.7	M32
2 Motor	1	34.7	M32
3 Brake/load sharing	1	34.7	M32
4 Control cable	1	34.7	M32
5 Control cable	1/2	22.5	M20
1) Tolerance ±0.2 mm			

Illustration 8.27 Enclosure Size B1, IP21

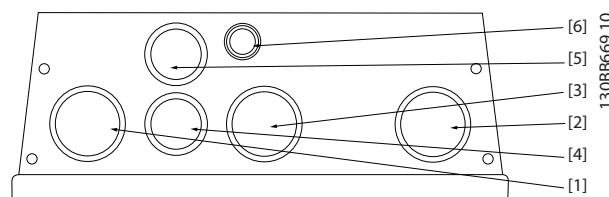

Hole number and recommended use	Nearest metric
1 Mains	M32
2 Motor	M32
3 Brake/load sharing	M32
4 Control cable	M25
5 Control cable	M25
6 Control cable	22.5 mm ¹⁾
1) Knock-out hole	

Illustration 8.29 Enclosure Size B1, IP55 Threaded Gland Holes

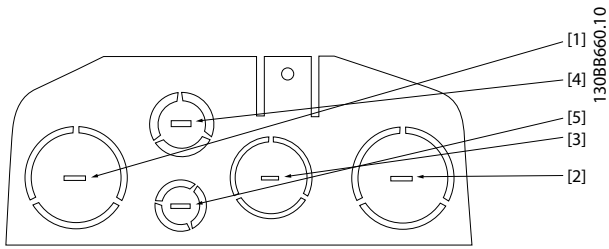

Hole number and recommended use	Dimensions ¹⁾		Nearest metric
	UL [in]	[mm]	
1 Mains	1 1/4	44.2	M40
2 Motor	1 1/4	44.2	M40
3 Brake/load sharing	1	34.7	M32
4 Control cable	3/4	28.4	M25
5 Control cable	1/2	22.5	M20

1) Tolerance ±0.2 mm

Illustration 8.30 Enclosure Size B2, IP21

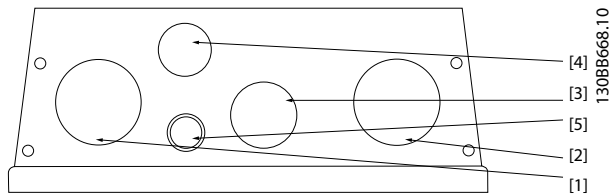

Hole number and recommended use	Dimensions ¹⁾		Nearest metric
	UL [in]	[mm]	
1 Mains	1 1/4	44.2	M40
2 Motor	1 1/4	44.2	M40
3 Brake/load sharing	1	34.7	M32
4 Control cable	3/4	28.4	M25
5 Control cable ²⁾	1/2	22.5	M20

1) Tolerance ±0.2 mm
2) Knock-out hole

Illustration 8.31 Enclosure Size B2, IP55

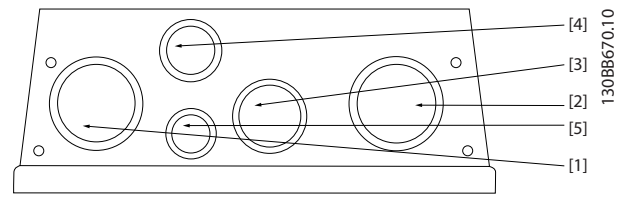

Hole number and recommended use	Nearest metric
1 Mains	M40
2 Motor	M40
3 Brake/load sharing	M32
4 Control cable	M25
5 Control cable	M20

Illustration 8.32 Enclosure Size B2, IP55 Threaded Gland Holes

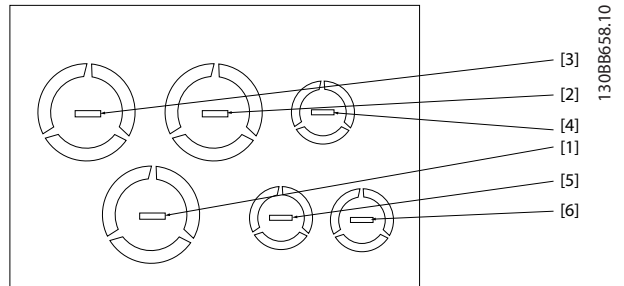

Hole number and recommended use	Dimensions ¹⁾		Nearest metric
	UL [in]	[mm]	
1 Mains	1	34.7	M32
2 Motor	1	34.7	M32
3 Brake/load sharing	1	34.7	M32
4 Control cable	1/2	22.5	M20
5 Control cable	1/2	22.5	M20
6 Control cable	1/2	22.5	M20

1) Tolerance ±0.2 mm

Illustration 8.33 Enclosure Size B3, IP21

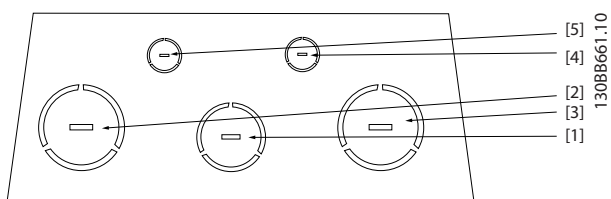

Hole number and recommended use	Dimensions ¹⁾		Nearest metric
	UL [in]	[mm]	
1 Mains	2	63.3	M63
2 Motor	2	63.3	M63
3 Brake/load sharing	1 1/2	50.2	M50
4 Control cable	3/4	28.4	M25
5 Control cable	1/2	22.5	M20

1) Tolerance ±0.2 mm

8

Illustration 8.34 Enclosure Size C1, IP21

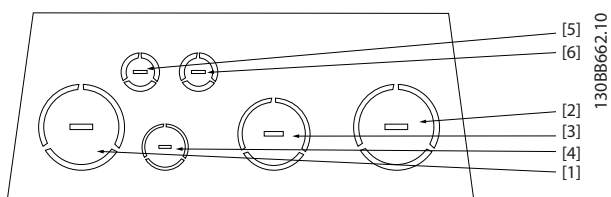

Hole number and recommended use		Dimensions ¹⁾		Nearest metric
		UL [in]	[mm]	
1	Mains	2	63.3	M63
2	Motor	2	63.3	M63
3	Brake/load sharing	1 1/2	50.2	M50
4	Control cable	3/4	28.4	M25
5	Control cable	1/2	22.5	M20
6	Control cable	1/2	22.5	M20

1) Tolerance ±0.2 mm

Illustration 8.35 Enclosure Size C2, IP21

Index

A

Abbreviations..... 8, 45

AC

current..... 18

input..... 17

mains..... 17

waveform..... 17

Acoustic noise..... 37

Acoustic noise rating..... 135

Address field..... 79

AEO..... 8

see also *Automatic energy optimisation*

Affinity laws..... 15

Airflow..... 36, 37, 38, 109

Airflow calculation..... 36

AMA..... 8, 27

see also *Automatic motor adaptation*

Analog I/O..... 65

Analog speed reference..... 96

Application

Application..... 14

Cascade control..... 14

Real-time clock..... 91

Zone control..... 14

Auto on..... 20, 21

Automatic energy optimisation..... 8, 25, 27

see also *AEO*

Automatic motor adaptation..... 8, 27

see also *AMA*

Autoramping..... 37

B

Backplate..... 63

Back-up power system..... 55

Brake

option..... 64

Braking..... 29

Braking current..... 83

Brake resistor

Brake resistor..... 8, 24

C

Cabinet heater..... 35

Cabinet options..... 39

Cable

entry..... 146

Entry holes..... 146

Motor cable... 26, 39, 40, 41, 48, 55, 56, 58, 61, 66, 69, 71, 99,
100, 133

Motor cable length..... 44, 47, 56, 69

Screened cable..... 62

Unshielded motor cable..... 55

Cascade control..... 14

CDM..... 50

CFM..... 37

Circuit breaker..... 24, 48, 54, 64, 127

Clearance..... 36, 39, 61, 62

Closed loop..... 19, 20, 21, 28, 31, 80

Coast..... 9, 28, 30, 78, 80, 81, 83, 84, 86, 87, 91

Coating..... 37, 63

Coil register..... 80

Comparator..... 29, 30, 91

Compliance

CE..... 10

CE mark..... 10

C-tick..... 11

Galvanic isolation..... 27, 33, 39, 40, 138

Marine compliance..... 11

UL listed..... 11

Condensation..... 35

Conducted emission..... 42

Contactor..... 64

Control

logic..... 17

wiring..... 62

Conventions..... 9

Conversion factor..... 77, 82

Conversion index..... 77, 78

Cooling..... 26, 27, 31, 34, 36, 37, 38, 58, 63, 64, 99, 109

Cooling conditions..... 62

Cos ϕ 54, 65, 136, 138

CRC check field..... 80

Current	
Current.....	45
distortion.....	46, 109
limit.....	8, 25, 26
loops.....	40
measurement.....	27
DC current.....	17
Fundamental current.....	45
Harmonic current.....	45
Harmonic current distortion.....	66
High current.....	31
Individual harmonic current.....	46
Input current.....	45
Intermediate current voltage.....	40
Leakage current.....	40, 47, 48
Low current.....	31
Output current.....	26, 27, 56, 99, 101
Overcurrent.....	28
Rated current.....	43
Rated output current.....	8
Ripple current.....	31, 66
D	
Data	
control byte.....	74
field.....	80
type.....	77, 82
DC	
brake.....	78, 80, 83
current.....	28, 29
link.....	24, 133
Definition.....	9, 43, 46, 52
Delta connection.....	143
Derating	
Ambient temperature.....	100
Automatic.....	25
Constant torque applications (CT mode).....	99
Cooling.....	99
Derating.....	26, 31, 35, 89, 99, 101, 102
Large cross-section.....	99
Low air pressure.....	99
Manual.....	99
Running at low speed.....	99
Variable (quadratic) torque applications (VT).....	99
Dimensions.....	68, 70, 89, 132, 146, 147, 148, 149
Directive	
EMC.....	10
ErP.....	11
Low-voltage.....	10
Machinery.....	10
Directives	
EMC Directive.....	10
Low Voltage Directive.....	10
Machinery Directive.....	11
Discharge time.....	13
Disconnect.....	18, 64
Dry-run detection.....	14
DU/dt testing.....	133
Dust.....	34, 38, 39
Duty cycle.....	9
E	
Efficiency	
Efficiency.....	8, 25, 26, 27, 50, 58
class.....	49
Energy efficiency.....	49
Energy efficiency class.....	49
Motor efficiency.....	58
Electronic thermal relay.....	58
see also <i>ETR</i>	
EMC	
EMC.....	7, 40, 43, 44, 62
characteristic.....	52
effect.....	51
immunity.....	44
implementation.....	55
plan.....	43
property.....	52
Emission requirements.....	40, 43
Emissions.....	40
Immunity requirements.....	40, 43
Interference.....	62
End of curve detection.....	14
Energy efficiency class.....	122
Energy savings.....	14, 15, 29
Environment	
Industrial.....	43, 53, 54
Residential.....	43, 53, 54
Equipment optional.....	7
ETR.....	8, 25, 27, 58
see also <i>Electronic thermal relay</i>	
Export control regulations.....	12
External command.....	17
External interlock.....	97
Extreme running conditions.....	24
F	
Fan.....	10, 14, 16, 26, 28, 31, 34, 36, 37, 38, 68, 99, 109
FC profile	
Protocol overview.....	73
Telegram length (LGE).....	74
Feedback	
Feedback.....	21, 23, 59, 66, 80, 95
conversion.....	24
handling.....	23, 35
signal.....	19, 28

Filter		Intermediate section.....	18
AHF 005.....	109	Inverter.....	17
AHF 010.....	109	Inverter section.....	18
Common mode.....	114	IP rating definition.....	38
Common-mode filter.....	69	IP21/NEMA Type 1 enclosure kit.....	67
DU/dt.....	44, 55, 66, 113, 114, 133		
Filter.....	38		
Harmonic filter.....	66, 107, 109, 110	J	
LC.....	55, 56, 57, 133	Jog.....	84
Radio frequency interference.....	39		
see also <i>RFI</i>		K	
Sine-wave.....	18, 55, 66	Kinetic back-up.....	28
Flying start.....	25, 26, 28		
Free programmable texts.....	14	L	
Frequency bypass.....	28	Lambda.....	9, 53
Frequency converter address.....	74	Laws of Proportionality.....	15
Function field.....	80	LCP.....	8, 32, 59, 69, 88
Fuse.....	24, 64, 89, 127	see also <i>Local control panel</i>	
		Leakage current.....	13
G		Load sharing.....	12, 13, 146, 147, 148, 149, 150
Generator.....	24, 37, 47, 55	Local control panel.....	8, 32, 59
Ground leakage protection.....	40	see also <i>LCP</i>	
Grounding.....	27, 45, 48, 52, 140	Logic rule.....	29, 30, 91
H		M	
Hand on.....	20, 21	Magnetisation loss.....	51
Harmonics		Mains	
Analysis.....	45	connection.....	140
Calculation of harmonics.....	33, 47	drop-out.....	28
Emission requirements.....	46	shielding.....	63
Harmonic mitigation.....	47	supply.....	9, 45
Harmonics.....	7, 17, 35, 45, 46, 47, 52, 53, 54, 55	Transient.....	17, 54
distortion.....	9, 40, 45	Maintenance.....	38
emission standard.....	46	Mechanical mounting.....	62
Test result.....	46	Minimum speed monitor.....	14
Total harmonic distortion.....	45	Modbus RTU	
Voltage harmonics.....	46	Exception code.....	82
High altitude.....	40, 99	Function code.....	81
High voltage.....	12	Message framing structure.....	79
High-frequency common-mode core.....	69	Message structure.....	79
Horizontal clearance.....	62	Network configuration.....	79
Humidity.....	35, 37, 39, 89	Overview.....	78
		Protocol.....	78
I		RS485 interface.....	78
I/O.....	64, 65, 66, 6, 138	Modulation.....	8, 25, 100, 101, 102, 103
Improved control.....	16	Moment of inertia.....	24
Index (IND).....	76, 82		
Initialising.....	9		
Input power.....	17, 62		
Insulation resistance monitor.....	63		
Interlock.....	97		
Intermediate circuit.....	17		

Motor	
Bearing current.....	44
Bearing stress.....	55
Grounding.....	55
Insulation.....	44
Insulation stress.....	55
Missing motor phase.....	24
alternation.....	14, 91
connection.....	143
current.....	17, 25, 58, 85
output.....	121
phases.....	24
starter.....	16, 64
thermal protection.....	11, 27, 57, 85, 98
thermistor.....	98
torque.....	88
voltage.....	133
wiring.....	62
Peak voltage.....	133
Thermal stress.....	55
Thermistor.....	98
Mounting bracket.....	70
Multi-feedback evaporator control.....	14
O	
Oil return.....	14
Open loop.....	19
Option	
AK-LonWorks.....	66
Cascade controller.....	33
Extended Relay Card MCB 113.....	66
PROFIBUS.....	64
PROFINET.....	65
Relay card.....	11, 66, 136
Relay Card.....	138
Ordering	
Common mode filter.....	114
DU/dt filter.....	113
Harmonic filter.....	107
Options and accessories.....	105
Sine-wave filter.....	107, 108, 111
Output contactor.....	58, 61
OVC.....	24
see also <i>Overvoltage control</i>	
Overload	
Normal overload mode.....	100, 102
Overload.....	27, 45, 57, 64
LED.....	64
protection.....	14, 25, 64
setpoint.....	27
Overtemperature.....	9, 25, 26, 31, 64, 85
Overvoltage	
Motor-generated overvoltage.....	24
Overvoltage.....	24, 37
control.....	24
P	
Pack control.....	91
Parameter block.....	75
Parameter number (PNU).....	76
Parameter value (PWE).....	76
Password protection.....	14
Payback period.....	15
PC software.....	33
PCD.....	75, 77
PELV.....	8, 27, 39, 40, 98, 99, 136
Phase imbalance.....	25, 31
PID controller.....	19, 20, 23, 28
Pilz.....	64
PKE field.....	76
Point of common coupling.....	46
Potentiometer.....	96
Potentiometer reference.....	93
Power factor.....	9, 17, 53, 54, 55
Power loss.....	50
Power ratings.....	132
Precautions.....	12
Preheat.....	28
Preventive maintenance.....	33
Process block.....	75
Process word.....	77
PT1000.....	65
PTC sensor.....	27
Public supply network.....	46
Pulse start/stop.....	92
Pulse width modulation.....	18
Q	
Qualified personnel.....	12
Quick Menu.....	32
R	
Radiated emission.....	42
Radio frequency interference.....	26, 53, 63
see also <i>RFI</i>	
RCD.....	8, 48, 63
Real-time clock.....	33
Rectifier.....	17, 18
Rectifier diode.....	45
Rectifier section.....	18

Reference	
Reference.....	93
external.....	21
handling.....	21, 22
preset.....	21
Remote reference.....	20, 21
Relay	
Built-in relay.....	78
Output relay.....	27, 86
Relay.....	11, 25, 40, 59, 137, 138
04.....	84
1.....	80, 83, 84
2.....	80, 83
7.....	137
8.....	137
9.....	137
connection.....	60
option.....	60, 65
output.....	60
terminal.....	39, 136, 145
SPDT alarm relay.....	63
SPDT relay.....	138
Remote mounting kit.....	69
Resonance damping.....	26
RFI	
RFI.....	18, 26, 37, 40, 53, 55
filter.....	18, 37, 39, 47, 53, 63, 64
Rise time.....	133
RMS current.....	17
RS485	
Bus termination.....	72
EMC precautions.....	73
Installation and set-up.....	71
Network connection.....	72
RS485.....	9, 20, 32, 33, 40, 69, 71, 72, 73, 137
Serial interface RS485.....	71
Run permissive.....	29, 97
Run/Stop command.....	97
S	
Safety.....	12, 13, 30, 66, 140, 143
Sensor current.....	18
Sensor thermal.....	18
Serial communication	
Control bit.....	83, 86
Control card, USB serial communication.....	126
Control word.....	83, 86
Control word bit.....	83, 86
Status word.....	84, 87
Setpoint.....	21
Shielding.....	55, 56
Shock.....	37
Short circuit	
Short circuit.....	10, 18, 27, 30, 36, 54, 64
Short circuit (motor phase – phase).....	24
Short-circuit protection.....	24
Short-circuit ratio.....	46
Side-by-side installation.....	62
Sleep mode.....	14, 26, 29, 91
Slip compensation.....	9, 24
Smart logic control.....	9, 14, 29, 33, 91, 93, 94
SmartStart.....	91
Soft starter.....	16
Software	
Harmonic calculation software (HCS).....	33, 53
HCS.....	55
see also <i>Harmonic Calculation Software</i>	
MCT 10 Set-up Software.....	33
MCT 31.....	33
Software version.....	106
Speed limit.....	19, 25, 57
Speed reference.....	96
Standards	
EN 50598.....	49
EN 50598-2.....	50
Standards and directives	
EN 50598-2.....	50, 122
Star connection.....	143
Star/Delta Starter.....	16
Start/stop.....	92
Start/stop field.....	79
Status word.....	75, 77, 80, 81, 85
STO.....	7, 14, 30, 59, 91
Storage.....	32, 33, 34, 35, 82, 90
Switching	
frequency.....	25, 26, 31, 36, 45, 48, 51, 58, 66, 101, 102, 103, 111, 112, 114
loss.....	51
on the output.....	25
System design checklist.....	89
T	
Telegram length.....	74, 77
Telegram structure.....	74
Temperature	
Temperature.....	36
ambient.....	36
average.....	36
control.....	14
maximum.....	36
Terminal 37.....	30, 59
Text block.....	75, 82
Thermal protection.....	11
Thermistor.....	9, 39, 57, 64

Tightening, terminals.....	126
Torque	
Constant torque.....	8
CT characteristics.....	9
Full torque.....	28
Rated torque.....	58
characteristics.....	121
limit.....	8, 25, 57, 85
Variable torque.....	8
VT characteristics.....	10
Transformer.....	45
Transient.....	38, 48
Transient protection.....	17
Trip	
Trip.....	9, 25, 26, 27, 28, 30, 31, 54, 58, 64, 78, 83, 84, 85, 87, 88, 98, 99
lock.....	10, 24
U	
U/f.....	58
Undervoltage.....	52
Unintended motor rotation.....	13
Unintended start.....	13
UPEAK.....	133
V	
Valve control.....	28
Variable control of flow and pressure.....	16
Varying flow over 1 year.....	15
Ventilation.....	109
Vertical clearance.....	62
Vibration.....	37
Voltage level.....	123
VVC+.....	8, 18
W	
Wall mounting.....	63
Weight.....	35, 89, 114, 132
Windmilling.....	13
Wiring	
Relay wiring.....	137
Wiring.....	39, 45, 59, 61, 89
schematic.....	59
Wizard.....	14



.....
Danfoss can accept no responsibility for possible errors in catalogues, brochures and other printed material. Danfoss reserves the right to alter its products without notice. This also applies to products already on order provided that such alterations can be made without subsequential changes being necessary in specifications already agreed. All trademarks in this material are property of the respective companies. Danfoss and the Danfoss logotype are trademarks of Danfoss A/S. All rights reserved.
.....

Danfoss A/S
Ulsnaes 1
DK-6300 Graasten
vlt-drives.danfoss.com

