



# Design Guide

## VLT<sup>®</sup> HVAC Drive FC 102

1.1-90 kW





## Contents

<b>1 How to Read this Design Guide</b>	<b>6</b>
<b>2 Introduction to VLT<sup>®</sup> HVAC Drive</b>	<b>11</b>
2.1 Safety	11
2.2 CE Labelling	12
2.3 Air humidity	13
2.4 Aggressive Environments	13
2.5 Vibration and Shock	14
2.6 Safe Torque Off	14
2.7 Advantages	20
2.8 Control Structures	33
2.9 General Aspects of EMC	41
2.10 Galvanic Isolation (PELV)	46
2.11 Earth Leakage Current	46
2.12 Brake Function	47
2.13 Extreme Running Conditions	49
<b>3 Selection</b>	<b>52</b>
3.1 Options and Accessories	52
3.1.1 Mounting of Option Modules in Slot B	52
3.1.2 General Purpose I/O Module MCB 101	52
3.1.3 Digital Inputs - Terminal X30/1-4	53
3.1.4 Analog Voltage Inputs - Terminal X30/10-12	53
3.1.5 Digital Outputs - Terminal X30/5-7	53
3.1.6 Analog Outputs - Terminal X30/5+8	53
3.1.7 Relay Option MCB 105	54
3.1.8 24 V Back-Up Option MCB 107 (Option D)	56
3.1.9 Analog I/O option MCB 109	57
3.1.10 PTC Thermistor Card MCB 112	58
3.1.11 Sensor Input Option MCB 114	60
3.1.11.1 Ordering Code Numbers and Parts Delivered	60
3.1.11.2 Electrical and Mechanical Specifications	60
3.1.11.3 Electrical Wiring	61
3.1.12 Remote Mounting Kit for LCP	61
3.1.13 IP21/IP41/ TYPE1 Enclosure Kit	62
3.1.14 IP21/Type 1 Enclosure Kit	62
3.1.15 Output Filters	64
<b>4 How to Order</b>	<b>65</b>
4.1 Ordering Form	65

4.2 Ordering Numbers	67
<b>5 Mechanical Installation</b>	<b>77</b>
5.1 Mechanical Installation	77
5.1.1 Safety Requirements of Mechanical Installation	77
5.1.2 Mechanical Dimensions	78
5.1.3 Accessory Bags	80
5.1.4 Mechanical Mounting	81
5.1.5 Field Mounting	82
<b>6 Electrical Installation</b>	<b>83</b>
6.1 Connections - Enclosure Types A, B and C	83
6.1.1 Torque	83
6.1.2 Removal of Knockouts for Extra Cables	84
6.1.3 Connection to Mains and Earthing	84
6.1.4 Motor Connection	86
6.1.5 Relay Connection	94
6.2 Fuses and Circuit Breakers	95
6.2.1 Fuses	95
6.2.2 Recommendations	95
6.2.3 CE Compliance	95
6.2.4 Fuse Tables	96
6.3 Disconnectors and Contactors	104
6.4 Additional Motor Information	104
6.4.1 Motor Cable	104
6.4.2 Motor Thermal Protection	105
6.4.3 Parallel Connection of Motors	105
6.4.4 Direction of Motor Rotation	107
6.4.5 Motor Insulation	107
6.4.6 Motor Bearing Currents	108
6.5 Control Cables and Terminals	108
6.5.1 Access to Control Terminals	108
6.5.2 Control Cable Routing	108
6.5.3 Control Terminals	109
6.5.4 Switches S201, S202, and S801	110
6.5.5 Electrical Installation, Control Terminals	110
6.5.6 Basic Wiring Example	111
6.5.7 Electrical Installation, Control Cables	112
6.5.8 Relay Output	114
6.6 Additional Connections	114
6.6.1 DC Bus Connection	114

6.6.2 Load Sharing	114
6.6.3 Installation of Brake Cable	114
6.6.4 How to Connect a PC to the Frequency Converter	115
6.6.5 PC Software	115
6.6.6 MCT 31	115
<b>6.7 Safety</b>	<b>115</b>
6.7.1 High Voltage Test	115
6.7.2 Grounding	116
6.7.3 Safety Ground Connection	116
6.7.4 ADN-compliant Installation	116
<b>6.8 EMC-correct Installation</b>	<b>116</b>
6.8.1 Electrical Installation - EMC Precautions	116
6.8.2 Use of EMC-Correct Cables	118
6.8.3 Grounding of Screened Control Cables	119
6.8.4 RFI Switch	119
6.9 Residual Current Device	120
6.10 Final Set-up and Test	120
<b>7 Application Examples</b>	<b>122</b>
7.1 Application Examples	122
7.1.1 Start/Stop	122
7.1.2 Pulse Start/Stop	122
7.1.3 Potentiometer Reference	123
7.1.4 Automatic Motor Adaptation (AMA)	123
7.1.5 Smart Logic Control	123
7.1.6 Smart Logic Control Programming	123
7.1.7 SLC Application Example	124
7.1.8 Cascade Controller	125
7.1.9 Pump Staging with Lead Pump Alternation	126
7.1.10 System Status and Operation	126
7.1.11 Fixed Variable Speed Pump Wiring Diagram	127
7.1.12 Lead Pump Alternation Wiring Diagram	127
7.1.13 Cascade Controller Wiring Diagram	128
7.1.14 Start/Stop Conditions	129
<b>8 Installation and Set-up</b>	<b>130</b>
8.1 Installation and Set-up	130
8.2 FC Protocol Overview	131
8.3 Network Configuration	132
8.4 FC Protocol Message Framing Structure	132
8.4.1 Content of a Character (byte)	132

8.4.2 Telegram Structure	132
8.4.3 Telegram Length (LGE)	132
8.4.4 Frequency Converter Address (ADR)	132
8.4.5 Data Control Byte (BCC)	133
8.4.6 The Data Field	133
8.4.7 The PKE Field	134
8.4.8 Parameter Number (PNU)	134
8.4.9 Index (IND)	134
8.4.10 Parameter Value (PWE)	134
8.4.11 Data Types Supported by the Frequency Converter	135
8.4.12 Conversion	135
8.4.13 Process Words (PCD)	135
8.5 Examples	135
8.5.1 Writing a Parameter Value	135
8.5.2 Reading a Parameter Value	136
8.6 Modbus RTU Overview	136
8.6.1 Assumptions	136
8.6.2 What the User Should Already Know	136
8.6.3 Modbus RTU Overview	136
8.6.4 Frequency Converter with Modbus RTU	137
8.7 Network Configuration	137
8.8 Modbus RTU Message Framing Structure	137
8.8.1 Frequency Converter with Modbus RTU	137
8.8.2 Modbus RTU Message Structure	137
8.8.3 Start/Stop Field	138
8.8.4 Address Field	138
8.8.5 Function Field	138
8.8.6 Data Field	138
8.8.7 CRC Check Field	138
8.8.8 Coil Register Addressing	138
8.8.9 How to Control the Frequency Converter	140
8.8.10 Function Codes Supported by Modbus RTU	140
8.8.11 Modbus Exception Codes	140
8.9 How to Access Parameters	140
8.9.1 Parameter Handling	140
8.9.2 Storage of Data	141
8.9.3 IND	141
8.9.4 Text Blocks	141
8.9.5 Conversion Factor	141
8.9.6 Parameter Values	141

8.10 Examples	141
8.10.1 Read Coil Status (01 HEX)	141
8.10.2 Force/Write Single Coil (05 HEX)	142
8.10.3 Force/Write Multiple Coils (0F HEX)	142
8.10.4 Read Holding Registers (03 HEX)	142
8.10.5 Preset Single Register (06 HEX)	143
8.10.6 Preset Multiple Registers (10 HEX)	143
8.11 Danfoss FC Control Profile	144
8.11.1 Control Word According to FC Profile (8-10 Control Profile = FC profile)	144
8.11.2 Status Word According to FC Profile (STW) (8-10 Control Profile = FC profile)	145
8.11.3 Bus Speed Reference Value	146
<b>9 General Specifications and Troubleshooting</b>	<b>147</b>
9.1 Mains Supply Tables	147
9.2 General Specifications	156
9.3 Efficiency	160
9.4 Acoustic Noise	160
9.5 Peak Voltage on Motor	161
9.6 Special Conditions	164
9.6.1 Purpose of Derating	164
9.6.2 Derating for Ambient Temperature	164
9.6.3 Derating for Ambient Temperature, Enclosure Type A	164
9.6.4 Derating for Ambient Temperature, Enclosure Type B	165
9.6.5 Derating for Ambient Temperature, Enclosure Type C	167
9.6.6 Automatic Adaptations to Ensure Performance	169
9.6.7 Derating for Low Air Pressure	169
9.6.8 Derating for Running at Low Speed	169
9.7 Troubleshooting	170
9.7.1 Alarm Words	174
9.7.2 Warning Words	175
9.7.3 Extended Status Words	176
<b>Index</b>	<b>183</b>

## 1 How to Read this Design Guide

**VLT® HVAC Drive  
FC 102 Series**



This guide can be used with all  
VLT® HVAC Drive frequency  
converters with software version  
3.9x.  
The actual software version  
number can be read from  
*15-43 Software Version.*

**Table 1.1 Software Version**

This publication contains information proprietary to Danfoss. By accepting and using this manual the user agrees that the information contained herein is used solely for operating equipment from Danfoss or equipment from other vendors if such equipment is intended for communication with Danfoss equipment over a serial communication link. This publication is protected under the Copyright laws of Denmark and most other countries.

Danfoss does not warrant that a software program produced according to the guidelines provided in this manual functions properly in every physical, hardware or software environment.

Although Danfoss has tested and reviewed the documentation within this manual, Danfoss makes no warranty or representation, neither expressed nor implied, with respect to this documentation, including its quality, performance, or fitness for a particular purpose.

In no event shall Danfoss be liable for direct, indirect, special, incidental, or consequential damages arising out of the use, or the inability to use information contained in this manual, even if advised of the possibility of such damages. In particular, Danfoss is not responsible for any costs, including but not limited to those incurred as a result of lost profits or revenue, loss or damage of equipment, loss of computer programs, loss of data, the costs to substitute these, or any claims by third parties.

Danfoss reserves the right to revise this publication at any time and to make changes to its contents without prior notice or any obligation to notify former or present users of such revisions or changes.

- *Design Guide* entails all technical information about the frequency converter and customer design and applications.
- *Programming Guide* provides information on how to programme and includes complete parameter descriptions.
- *Application Note, Temperature Derating Guide*
- *MCT 10 Set-up Software Operating Instructions* enables the user to configure the frequency converter from a Windows™ based PC environment.
- Danfoss VLT® Energy Box software at [www.danfoss.com/BusinessAreas/DrivesSolutions](http://www.danfoss.com/BusinessAreas/DrivesSolutions) then choose PC Software Download
- *VLT® HVAC Drive BACnet, Operating Instructions*
- *VLT® HVAC Drive Metasys, Operating Instructions*
- *VLT® HVAC Drive FLN, Operating Instructions*

Danfoss technical literature is available in print from local Danfoss Sales Offices or online at:  
[www.danfoss.com/BusinessAreas/DrivesSolutions/Documentations/Technical+Documentation.htm](http://www.danfoss.com/BusinessAreas/DrivesSolutions/Documentations/Technical+Documentation.htm)

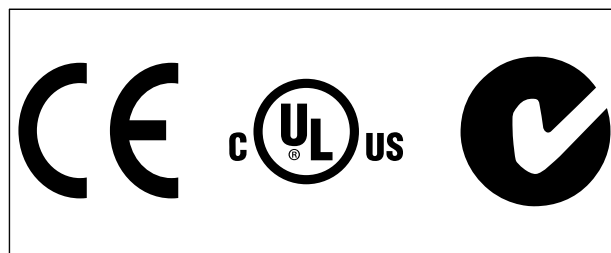

**Table 1.2**

The frequency converter complies with UL508C thermal memory retention requirements. For more information, refer to *chapter 6.4.2 Motor Thermal Protection*.



The following symbols are used in this document.

### **⚠ WARNING**

Indicates a potentially hazardous situation which could result in death or serious injury.

### **⚠ CAUTION**

Indicates a potentially hazardous situation which could result in minor or moderate injury. It may also be used to alert against unsafe practices.

### **NOTICE**

Indicates important information, including situations that may result in damage to equipment or property.

Alternating current	AC
American wire gauge	AWG
Ampere/AMP	A
Automatic Motor Adaptation	AMA
Current limit	$I_{LIM}$
Degrees Celsius	°C
Direct current	DC
Drive Dependent	D-TYPE
Electro Magnetic Compatibility	EMC
Electronic Thermal Relay	ETR
Frequency converter	FC
Gram	g
Hertz	Hz
Horsepower	hp
Kilohertz	kHz
Local Control Panel	LCP
Meter	m
Millihenry Inductance	mH
Milliamper	mA
Millisecond	ms
Minute	min
Motion Control Tool	MCT
Nanofarad	nF
Newton Meters	Nm
Nominal motor current	$I_{M,N}$
Nominal motor frequency	$f_{M,N}$
Nominal motor power	$P_{M,N}$
Nominal motor voltage	$U_{M,N}$
Permanent Magnet motor	PM motor
Protective Extra Low Voltage	PELV
Printed Circuit Board	PCB
Rated Inverter Output Current	$I_{INV}$
Revolutions Per Minute	RPM
Regenerative terminals	Regen
Second	s
Synchronous Motor Speed	$n_s$
Torque limit	$T_{LIM}$
Volts	V
The maximum output current	$I_{VLT,MAX}$
The rated output current supplied by the frequency converter	$I_{VLT,N}$

**Table 1.3 Abbreviations**

### 1.1.1 Definitions

#### Frequency Converter:

$I_{VLT,MAX}$

The maximum output current.

$I_{VLT,N}$

The rated output current supplied by the frequency converter.

$U_{VLT, MAX}$

The maximum output voltage.

#### Input:

<b>Control command</b> Start and stop the connected motor with the LCP or the digital inputs. Functions are divided into two groups. Functions in group 1 have higher priority than functions in group 2.	Group 1	Reset, Coasting stop, Reset and Coasting stop, Quick-stop, DC braking, Stop and the "Off" key.
	Group 2	Start, Pulse start, Reversing, Start reversing, Jog and Freeze output

Table 1.4 Function Groups

#### Motor:

$f_{JOG}$

The motor frequency when the jog function is activated (via digital terminals).

$f_M$

The motor frequency.

$f_{MAX}$

The maximum motor frequency.

$f_{MIN}$

The minimum motor frequency.

$f_{M,N}$

The rated motor frequency (nameplate data).

$I_M$

The motor current.

$I_{M,N}$

The rated motor current (nameplate data).

$n_{M,N}$

The rated motor speed (nameplate data).

$P_{M,N}$

The rated motor power (nameplate data).

$T_{M,N}$

The rated torque (motor).

$U_M$

The instantaneous motor voltage.

$U_{M,N}$

The rated motor voltage (nameplate data).

#### Break-away torque

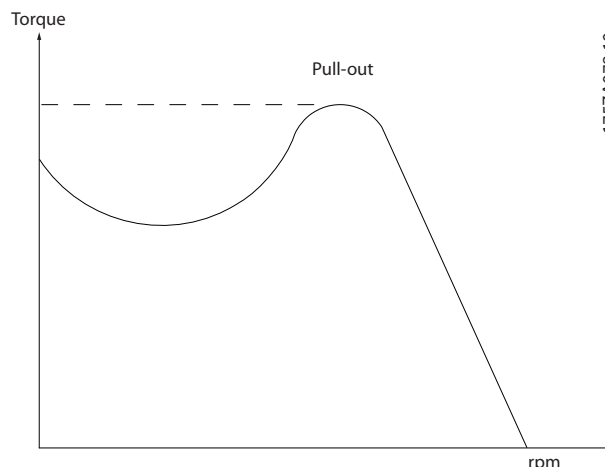

175ZA078.10

Illustration 1.1 Break-away Torque

$\eta_{VLT}$

The efficiency of the frequency converter is defined as the ratio between the power output and the power input.

#### Start-disable command

A stop command belonging to the group 1 control commands - see Table 1.4.

#### Stop command

See Control commands.

#### References:

##### Analog Reference

A signal transmitted to the analog inputs 53 or 54, can be voltage or current.

##### Bus Reference

A signal transmitted to the serial communication port (FC port).

##### Preset Reference

A defined preset reference to be set from -100% to +100% of the reference range. Selection of 8 preset references via the digital terminals.

##### Pulse Reference

A pulse frequency signal transmitted to the digital inputs (terminal 29 or 33).

##### Ref<sub>MAX</sub>

Determines the relationship between the reference input at 100% full scale value (typically 10 V, 20mA) and the resulting reference. The maximum reference value set in 3-03 Maximum Reference.

##### Ref<sub>MIN</sub>

Determines the relationship between the reference input at 0% value (typically 0V, 0mA, 4mA) and the resulting reference. The minimum reference value set in 3-02 Minimum Reference

**Miscellaneous:****Advanced Vector Control****Analog Inputs**

The analog inputs are used for controlling various functions of the frequency converter.

There are 2 types of analog inputs:

Current input, 0-20 mA and 4-20 mA

Voltage input, 0-10 V DC.

**Analog Outputs**

The analog outputs can supply a signal of 0-20 mA, 4-20 mA, or a digital signal.

**Automatic Motor Adaptation, AMA**

AMA algorithm determines the electrical parameters for the connected motor at standstill.

**Brake Resistor**

The brake resistor is a module capable of absorbing the brake power generated in regenerative braking. This regenerative braking power increases the intermediate circuit voltage and a brake chopper ensures that the power is transmitted to the brake resistor.

**CT Characteristics**

Constant torque characteristics used for screw and scroll refrigeration compressors.

**Digital Inputs**

The digital inputs can be used for controlling various functions of the frequency converter.

**Digital Outputs**

The frequency converter features 2 Solid State outputs that can supply a 24 V DC (max. 40 mA) signal.

**DSP**

Digital Signal Processor.

**Relay Outputs**

The frequency converter features 2 programmable Relay Outputs.

**ETR**

Electronic Thermal Relay is a thermal load calculation based on present load and time. Its purpose is to estimate the motor temperature.

**GLCP**

Graphical Local Control Panel (LCP102)

**Initialising**

If initialising is carried out (*14-22 Operation Mode*), the programmable parameters of the frequency converter return to their default settings.

**Intermittent Duty Cycle**

An intermittent duty rating refers to a sequence of duty cycles. Each cycle consists of an on-load and an off-load period. The operation can be either periodic duty or non-periodic duty.

**LCP**

The Local Control Panel makes up a complete interface for control and programming of the frequency converter. The LCP is detachable and can be installed up to 3 metres from the frequency converter, i.e. in a front panel by means of the installation kit option.

The LCP is available in 2 versions:

- Numerical LCP101 (NLCP)
- Graphical LCP102 (GLCP)

**lsb**

Least significant bit.

**MCM**

Short for Mille Circular Mil, an American measuring unit for cable cross-section. 1 MCM  $\equiv$  0.5067 mm<sup>2</sup>.

**msb**

Most significant bit.

**NLCP**

Numerical Local Control Panel LCP 101

**On-line/Off-line Parameters**

Changes to on-line parameters are activated immediately after the data value is changed. Press [OK] to activate changes to off-line parameters.

**PID Controller**

The PID controller maintains the desired speed, pressure, temperature, etc. by adjusting the output frequency to match the varying load.

**RCD**

Residual Current Device.

**Set-up**

Save parameter settings in 4 Set-ups. Change between the 4 parameter Set-ups and edit one Set-up, while another Set-up is active.

**SFAVM**

Switching pattern called Stator Flux oriented Asynchronous Vector Modulation (*14-00 Switching Pattern*).

**Slip Compensation**

The frequency converter compensates for the motor slip by giving the frequency a supplement that follows the measured motor load keeping the motor speed almost constant.

**Smart Logic Control (SLC)**

The SLC is a sequence of user-defined actions executed when the associated user-defined events are evaluated as true by the SLC.

**Thermistor**

A temperature-dependent resistor placed where the temperature is to be monitored (frequency converter or motor).

**Trip**

A state entered in fault situations, e.g. if the frequency converter is subject to an over temperature or when the frequency converter is protecting the motor, process or

mechanism. Restart is prevented until the cause of the fault has disappeared and the trip state is cancelled by activating reset or, in some cases, by being programmed to reset automatically. Trip may not be used for personal safety.

#### Trip Locked

A state entered in fault situations when the frequency converter is protecting itself and requiring physical intervention, e.g. if the frequency converter is subject to a short circuit on the output. A locked trip can only be cancelled by cutting off mains, removing the cause of the fault, and reconnecting the frequency converter. Restart is prevented until the trip state is cancelled by activating reset or, in some cases, by being programmed to reset automatically. Trip locked may not be used for personal safety.

#### VT Characteristics

Variable torque characteristics used for pumps and fans.

#### VVC<sup>plus</sup>

If compared with standard voltage/frequency ratio control, Voltage Vector Control (VVC<sup>plus</sup>) improves the dynamics and the stability, both when the speed reference is changed and in relation to the load torque.

#### 60 ° AVM

Switching pattern called 60° Asynchronous Vector Modulation (See 14-00 *Switching Pattern*).

### 1.1.2 Power Factor

The power factor is the relation between  $I_1$  and  $I_{RMS}$ .

$$\text{Power factor} = \frac{\sqrt{3} \times U \times I_1 \times \text{COS}\phi}{\sqrt{3} \times U \times I_{RMS}}$$

The power factor for 3-phase control:

$$= \frac{I_1 \times \text{cosp}1}{I_{RMS}} = \frac{I_1}{I_{RMS}} \text{ since cosp}1 = 1$$

The power factor indicates to which extent the frequency converter imposes a load on the mains supply.

The lower the power factor, the higher the  $I_{RMS}$  for the same kW performance.

$$I_{RMS} = \sqrt{I_1^2 + I_5^2 + I_7^2 + \dots + I_n^2}$$

In addition, a high power factor indicates that the different harmonic currents are low.

The frequency converter's built-in DC coils produce a high power factor, which minimises the imposed load on the mains supply.

## 2 Introduction to VLT® HVAC Drive

### 2.1 Safety

#### 2.1.1 Safety Note

#### **⚠ WARNING**

The voltage of the frequency converter is dangerous whenever connected to mains. Incorrect installation of the motor, frequency converter or fieldbus may cause death, serious personal injury or damage to the equipment. Consequently, the instructions in this manual, as well as national and local rules and safety regulations, must be complied with.

#### Safety Regulations

1. Disconnect the frequency converter from mains, if repair work is to be carried out. Check that the mains supply has been disconnected and that the necessary time has elapsed before removing motor and mains plugs.
2. The [Stop/Reset] key on the LCP of the frequency converter does not disconnect the equipment from mains and is thus not to be used as a safety switch.
3. Established correct protective earthing of the equipment, protect the user against supply voltage, and protect the motor against overload in accordance with applicable national and local regulations.
4. The earth leakage currents are higher than 3.5 mA.
5. Protection against motor overload is set by *1-90 Motor Thermal Protection*. If this function is desired, set *1-90 Motor Thermal Protection* to data value [ETR trip] (default value) or data value [ETR warning]. Note: The function is initialised at 1.16 x rated motor current and rated motor frequency. For the North American market: The ETR functions provide class 20 motor overload protection in accordance with NEC.
6. Do not remove the plugs for the motor and mains supply while the frequency converter is connected to mains. Check that the mains supply has been disconnected and that the necessary time has elapsed before removing motor and mains plugs.
7. Note that the frequency converter has more voltage inputs than L1, L2 and L3, when load sharing (linking of DC intermediate circuit) and external 24 V DC have been installed. Check that

all voltage inputs have been disconnected and that the necessary time has passed before commencing repair work.

#### Installation at high altitudes

#### **⚠ CAUTION**

380-500 V, enclosure types A, B and C: At altitudes above 2 km, contact Danfoss regarding PELV.  
525-690 V: At altitudes above 2 km, contact Danfoss regarding PELV.

#### **⚠ WARNING**

#### Warning against unintended start

1. The motor can be stopped with digital commands, bus commands, references or a local stop, while the frequency converter is connected to mains. If personal safety considerations make it necessary to ensure that no unintended start occurs, these stop functions are not sufficient.
2. While parameters are being changed, the motor may start. Consequently, the [Reset] key must always be activated; following which data can be modified.
3. A motor that has been stopped may start if faults occur in the electronics of the frequency converter, or if a temporary overload or a fault in the supply mains or the motor connection ceases.

#### **⚠ WARNING**

Touching the electrical parts may be fatal - even after the equipment has been disconnected from mains.

Also make sure that other voltage inputs have been disconnected, such as external 24 V DC, load sharing (linkage of DC intermediate circuit), as well as the motor connection for kinetic back-up. Refer to the *Operating Instructions* for further safety guidelines.

#### 2.1.2 Caution

#### **⚠ WARNING**

The DC link capacitors remain charged after power has been disconnected. To avoid an electrical shock hazard, disconnect the from the mains before carrying out maintenance. Wait at least as follows before doing service on the frequency converter:

Voltage [V]	Min. waiting time (minutes)	
	4	15
200-240	1.1-3.7 kW	5.5-45 kW
380-480	1.1-7.5 kW	11-90 kW
525-600	1.1-7.5 kW	11-90 kW
525-690		11 - 90 kW

Be aware that there may be high voltage on the DC link even when the LEDs are turned off.

Table 2.1 Discharge Time

### 2.1.3 Disposal Instruction

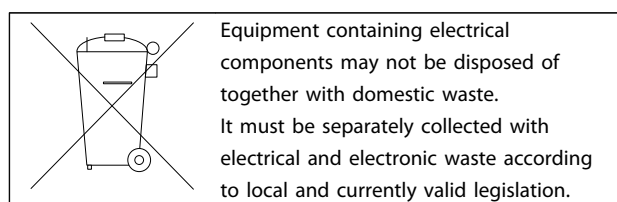

## 2.2 CE Labelling

### 2.2.1 CE Conformity and Labelling

#### What is CE Conformity and Labelling?

The purpose of CE labelling is to avoid technical trade obstacles within EFTA and the EU. The EU has introduced the CE label as a simple way of showing whether a product complies with the relevant EU directives. The CE label says nothing about the specifications or quality of the product. Frequency converters are regulated by 3 EU directives:

#### The machinery directive (2006/42/EC)

Frequency converters with integrated safety function are now falling under the Machinery Directive. Danfoss CE-labels in accordance with the directive and issues a declaration of conformity upon request. Frequency converters without safety function do not fall under the machinery directive. However, if a frequency converter is supplied for use in a machine, we provide information on safety aspects relating to the frequency converter.

#### The low-voltage directive (2006/95/EC)

Frequency converters must be CE labelled in accordance with the low-voltage directive of January 1, 1997. The directive applies to all electrical equipment and appliances used in the 50-1000 V AC and the 75-1500 V DC voltage ranges. Danfoss CE-labels in accordance with the directive and issues a declaration of conformity upon request.

#### The EMC directive (2004/108/EC)

EMC is short for electromagnetic compatibility. The presence of electromagnetic compatibility means that the mutual interference between different components/appliances does not affect the way the appliances work. The EMC directive came into effect January 1, 1996. Danfoss CE-labels in accordance with the directive and issues a declaration of conformity upon request. To carry

out EMC-correct installation, see the instructions in this *Design Guide*. In addition, Danfoss specifies which standards our products comply with. Danfoss offers the filters presented in the specifications and provide other types of assistance to ensure the optimum EMC result.

The frequency converter is most often used by professionals of the trade as a complex component forming part of a larger appliance, system or installation. It must be noted that the responsibility for the final EMC properties of the appliance, system or installation rests with the installer.

### 2.2.2 What Is Covered

The EU "Guidelines on the Application of Council Directive 2004/108/EC" outline 3 typical situations of using a frequency converter.

1. The frequency converter is sold directly to the end user. For such applications, the frequency converter must be CE labelled in accordance with the EMC directive.
2. The frequency converter is sold as part of a system. It is being marketed as complete system, e.g. an air-conditioning system. The complete system must be CE labelled in accordance with the EMC directive. The manufacturer can ensure CE labelling under the EMC directive by testing the EMC of the system. The components of the system need not to be CE marked.
3. The frequency converter is sold for installation in a plant. It could be a production or a heating/ventilation plant designed and installed by professionals of the trade. The frequency converter must be CE labelled under the EMC directive. The finished plant should not bear the CE mark. However, the installation must comply with the essential requirements of the directive. This is assumed by using appliances and systems that are CE labelled under the EMC directive

### 2.2.3 Danfoss Frequency Converter and CE Labelling

The purpose of CE labelling is to facilitate trade within the EU and EFTA.

However, CE labelling may cover many different specifications. Thus, check what a given CE label specifically covers.

The covered specifications can be very different and a CE label may therefore give the installer a false feeling of security when using a frequency converter as a component in a system or an appliance.

Danfoss CE labels the frequency converters in accordance with the low-voltage directive. This means that if the frequency converter is installed correctly, Danfoss guarantees compliance with the low-voltage directive. Danfoss issues a declaration of conformity that confirms our CE labelling in accordance with the low-voltage directive.

The CE label also applies to the EMC directive provided that the instructions for EMC-correct installation and filtering are followed. On this basis, a declaration of conformity in accordance with the EMC directive is issued.

This *Design Guide* offers detailed instructions for installation to ensure EMC-correct installation. Furthermore, Danfoss specifies which the different products comply with.

Danfoss provides other types of assistance that can help obtaining the best EMC result.

### 2.2.4 Compliance with EMC Directive 2004/108/EC

As mentioned, the frequency converter is mostly used by professionals of the trade as a complex component forming part of a larger appliance, system, or installation. Note that the responsibility for the final EMC properties of the appliance, system or installation rests with the installer. As an aid to the installer, Danfoss has prepared EMC installation guidelines for the Power Drive system. The standards and test levels stated for Power Drive systems are complied with, provided that the EMC-correct instructions for installation are followed, see .

### 2.3 Air humidity

The frequency converter has been designed to meet the IEC/EN 60068-2-3 standard, EN 50178 pkt. 9.4.2.2 at 50 °C.

### 2.4 Aggressive Environments

A frequency converter contains a large number of mechanical and electronic components. All are to some extent vulnerable to environmental effects.

#### **CAUTION**

**Do no install the frequency converter in environments with airborne liquids, particles, or gases capable of affecting and damaging the electronic components. Failure to take the necessary protective measures increases the risk of stoppages, thus reducing the life of the frequency converter.**

#### Degree of protection as per IEC 60529

The Safe Torque Off function may only be installed and operated in a control cabinet with degree of protection

IP54 or higher (or equivalent environment). This is required to avoid cross faults and short circuits between terminals, connectors, tracks and safety-related circuitry caused by foreign objects.

Liquids can be carried through the air and condense in the frequency converter and may cause corrosion of components and metal parts. Steam, oil, and salt water may cause corrosion of components and metal parts. In such environments, use equipment with enclosure rating IP 54/55. As an extra protection, coated printed circuit boards can be ordered as an option.

Airborne particles such as dust may cause mechanical, electrical, or thermal failure in the frequency converter. A typical indicator of excessive levels of airborne particles is dust particles around the frequency converter fan. In very dusty environments, use equipment with enclosure rating IP 54/55 or a cabinet for IP 00/IP 20/TYP 1 equipment.

In environments with high temperatures and humidity, corrosive gases such as sulphur, nitrogen, and chlorine compounds cause chemical processes on the frequency converter components.

Such chemical reactions rapidly affect and damage the electronic components. In such environments, mount the equipment in a cabinet with fresh air ventilation, keeping aggressive gases away from the frequency converter. An extra protection in such areas is a coating of the printed circuit boards, which can be ordered as an option.

#### **NOTICE**

**Mounting frequency converters in aggressive environments increases the risk of stoppages and considerably reduces the life of the frequency converter.**

Before installing the frequency converter, check the ambient air for liquids, particles, and gases. This is done by observing existing installations in this environment. Typical indicators of harmful airborne liquids are water or oil on metal parts, or corrosion of metal parts.

Excessive dust particle levels are often found on installation cabinets and existing electrical installations. One indicator of aggressive airborne gases is blackening of copper rails and cable ends on existing installations.

D and E enclosure types have a stainless steel back-channel option to provide additional protection in aggressive environments. Proper ventilation is still required for the internal components of the frequency converter. Contact Danfoss for additional information.

## 2.5 Vibration and Shock

The frequency converter has been tested according to the procedure based on the shown standards:

- IEC/EN 60068-2-6: Vibration (sinusoidal) - 1970
- IEC/EN 60068-2-64: Vibration, broad-band random

The frequency converter complies with requirements that exist for units mounted on the walls and floors of production premises, as well as in panels bolted to walls or floors.

## 2.6 Safe Torque Off

The FC 102 can perform the safety function *Safe Torque Off* (STO, as defined by EN IEC 61800-5-2<sup>1</sup>) and *Stop Category 0* (as defined in EN 60204-1<sup>2</sup>).

Before integrating and using Safe Torque Off in an installation, a thorough risk analysis on the installation must be carried out in order to determine whether the Safe Torque Off functionality and safety levels are appropriate and sufficient. It is designed and approved suitable for the requirements of :

- Category 3 in EN ISO 13849-1
- Performance Level "d" in EN ISO 13849-1:2008
- SIL 2 Capability in IEC 61508 and EN 61800-5-2
- SILCL 2 in EN 62061

1) Refer to EN IEC 61800-5-2 for details of Safe torque off (STO) function.

2) Refer to EN IEC 60204-1 for details of stop category 0 and 1.

### Activation and Termination of Safe Torque Off

The Safe Torque Off (STO) function is activated by removing the voltage at Terminal 37 of the Safe Inverter. By connecting the Safe Inverter to external safety devices providing a safe delay, an installation for a Safe Torque Off Category 1 can be obtained. The Safe Torque Off function of FC 102 can be used for asynchronous, synchronous motors and permanent magnet motors. See examples in *chapter 2.6.1 Terminal 37 Safe Torque Off Function*.

## **⚠ WARNING**

After installation of Safe Torque Off (STO), a commissioning test as specified in section *Safe Torque Off Commissioning Test* must be performed. A passed commissioning test is mandatory after first installation and after each change to the safety installation.

### Safe Torque Off Technical Data

The following values are associated to the different types of safety levels:

#### Reaction time for T37

- Maximum reaction time: 20 ms

Reaction time = delay between de-energizing the STO input and switching off the output bridge.

### Data for EN ISO 13849-1

- Performance Level "d"
- MTTFd (Mean Time To Dangerous Failure): 14000 years
- DC (Diagnostic Coverage): 90%
- Category 3
- Lifetime 20 years

### Data for EN IEC 62061, EN IEC 61508, EN IEC 61800-5-2

- SIL 2 Capability, SILCL 2
- PFH (Probability of Dangerous failure per Hour) = 1E-10/h
- SFF (Safe Failure Fraction) > 99%
- HFT (Hardware Fault Tolerance) = 0 (1001 architecture)
- Lifetime 20 years

### Data for EN IEC 61508 low demand

- PFDavg for 1 year proof test: 1E-10
- PFDavg for 3 year proof test: 1E-10
- PFDavg for 5 year proof test: 1E-10

No maintenance of the STO functionality is needed.

Take security measures, e.g. only skilled personnel must be able to access and install in closed cabinets.

### SISTEMA Data

From Danfoss, functional safety data is available via a data library for use with the SISTEMA calculation tool from the IFA (Institute for Occupational Safety and Health of the German Social Accident Insurance), and data for manual calculation. The library is permanently completed and extended.



Abbrev.	Ref.	Description
Cat.	EN ISO 13849-1	Category, level "B, 1-4"
FIT		Failure In Time: 1E-9 hours
HFT	IEC 61508	Hardware Fault Tolerance: HFT = n means, that n+1 faults could cause a loss of the safety function
MTTFd	EN ISO 13849-1	Mean Time To Failure - dangerous. Unit: years
PFH	IEC 61508	Probability of Dangerous Failures per Hour. This value shall be considered if the safety device is operated in high demand (more often than once per year) or continuous mode of operation, where the frequency of demands for operation made on a safety-related system is greater than one per year
PFD	IEC 61508	Average probability of failure on demand, value used for low demand operation.
PL	EN ISO 13849-1	Discrete level used to specify the ability of safety related parts of control systems to perform a safety function under foreseeable conditions. Levels a-e
SFF	IEC 61508	Safe Failure Fraction [%] ; Percentage part of safe failures and dangerous detected failures of a safety function or a subsystem related to all failures.
SIL	IEC 61508	Safety Integrity Level
STO	EN 61800-5-2	Safe Torque Off
SS1	EN 61800-5-2	Safe Stop 1

Table 2.2 Abbreviations Related to Functional Safety

## 2.6.1 Terminal 37 Safe Torque Off Function

The FC 102 is available with Safe Torque Off functionality via control terminal 37. Safe Torque Off disables the control voltage of the power semiconductors of the frequency converter output stage which in turn prevents generating the voltage required to rotate the motor. When the Safe Torque Off (T37) is activated, the frequency converter issues an alarm, trips the unit, and coasts the motor to a stop. Manual restart is required. The Safe Torque Off function can be used for stopping the frequency converter in emergency stop situations. In the normal operating mode when Safe Torque Off is not required, use the frequency converter's regular stop function instead. When automatic restart is used – the requirements according to ISO 12100-2 paragraph 5.3.2.5 must be fulfilled.

### Liability Conditions

It is the user's responsibility to ensure personnel installing and operating the Safe Torque Off function:

- Read and understand the safety regulations concerning health and safety/accident prevention
- Understand the generic and safety guidelines given in this description and the extended description in the *Design Guide*
- Have a good knowledge of the generic and safety standards applicable to the specific application

### Standards

Use of Safe Torque Off on terminal 37 requires that the user satisfies all provisions for safety including relevant laws, regulations and guidelines. The optional Safe Torque Off function complies with the following standards.

- IEC 60204-1: 2005 category 0 – uncontrolled stop
- IEC 61508: 1998 SIL2
- IEC 61800-5-2: 2007 – safe torque off (STO) function
- IEC 62061: 2005 SIL CL2
- ISO 13849-1: 2006 Category 3 PL d
- ISO 14118: 2000 (EN 1037) – prevention of unexpected start-up

The information and instructions of the *Operating Instructions* are not sufficient for a proper and safe use of the Safe Torque Off functionality. The related information and instructions of the relevant *Design Guide* must be followed.

### Protective Measures

- Safety engineering systems may only be installed and commissioned by qualified and skilled personnel
- The unit must be installed in an IP54 cabinet or in an equivalent environment. In special applications a higher IP degree may be necessary
- The cable between terminal 37 and the external safety device must be short circuit protected according to ISO 13849-2 table D.4
- If any external forces influence the motor axis (e.g. suspended loads), additional measures (e.g., a safety holding brake) are required to eliminate hazards

Safe Torque Off Installation and Set-Up

**WARNING**

**SAFE TORQUE OFF FUNCTION!**

The Safe Torque Off function does NOT isolate mains voltage to the frequency converter or auxiliary circuits. Perform work on electrical parts of the frequency converter or the motor only after isolating the mains voltage supply and waiting the length of time specified under Safety in this manual. Failure to isolate the mains voltage supply from the unit and waiting the time specified could result in death or serious injury.

- It is not recommended to stop the frequency converter by using the Safe Torque Off function. If a running frequency converter is stopped by using the function, the unit trips and stops by coasting. If this is not acceptable, e.g. causes danger, the frequency converter and machinery must be stopped using the appropriate stopping mode before using this function. Depending on the application a mechanical brake may be required.
- Concerning synchronous and permanent magnet motor frequency converters in case of a multiple IGBT power semiconductor failure: In spite of the activation of the Safe Torque Off function, the frequency converter system can produce an alignment torque which maximally rotates the motor shaft by  $180/p$  degrees.  $p$  denotes the pole pair number.
- This function is suitable for performing mechanical work on the frequency converter system or affected area of a machine only. It does not provide electrical safety. This function should not be used as a control for starting and/or stopping the frequency converter.

Meet the following requirements to perform a safe installation of the frequency converter:

1. Remove the jumper wire between control terminals 37 and 12 or 13. Cutting or breaking the jumper is not sufficient to avoid short-circuiting. (See jumper on *Illustration 2.1*.)
2. Connect an external Safety monitoring relay via a NO safety function (the instruction for the safety device must be followed) to terminal 37 (Safe Torque Off) and either terminal 12 or 13 (24 V DC). The Safety monitoring relay must comply with Category 3/PL "d" (ISO 13849-1) or SIL 2 (EN 62061).

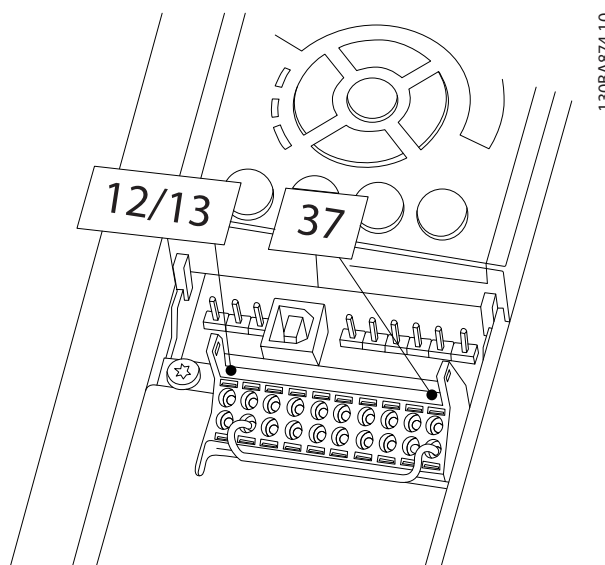

Illustration 2.1 Jumper between Terminal 12/13 (24 V) and 37

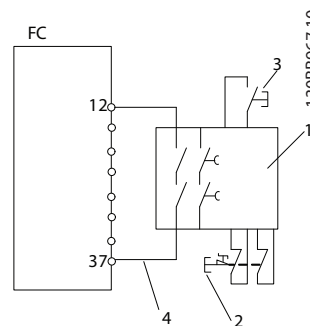

Illustration 2.2 Installation to Achieve a Stopping Category 0 (EN 60204-1) with Safety Cat. 3/PL "d" (ISO 13849-1) or SIL 2 (EN 62061).

1	Safety relay (cat. 3, PL d or SIL2)
2	Emergency stop button
3	Reset button
4	Short-circuit protected cable (if not inside installation IP54 cabinet)

Table 2.3 Legend to *Illustration 2.2*

**Safe Torque Off Commissioning Test**

After installation and before first operation, perform a commissioning test of the installation making use of Safe Torque Off. Moreover, perform the test after each modification of the installation.

**Example with STO**

A safety relay evaluates the E-Stop button signals and triggers an STO function on the frequency converter in the event of an activation of the E-Stop button (See *Illustration 2.3*). This safety function corresponds to a category 0 stop (uncontrolled stop) in accordance with IEC 60204-1. If the function is triggered during operation, the motor runs down in an uncontrolled manner. The power

to the motor is safely removed, so that no further movement is possible. It is not necessary to monitor plant at a standstill. If an external force effect is to be anticipated, provide additional measures to safely prevent any potential movement (e.g. mechanical brakes).

**NOTICE**

For all applications with Safe Torque Off, it is important that short circuit in the wiring to T37 can be excluded. This can be done as described in EN ISO 13849-2 D4 by the use of protected wiring, (shielded or segregated).

**Example with SS1**

SS1 correspond to a controlled stop, stop category 1 according to IEC 60204-1 (see *Illustration 2.4*). When activating the safety function, a normal controlled stop is performed. This can be activated through terminal 27. After the safe delay time has expired on the external safety module, the STO is triggered and terminal 37 is set low. Ramp down is performed as configured in the frequency converter. If the frequency converter is not stopped after the safe delay time, the activation of STO coasts the frequency converter.

**NOTICE**

When using the SS1 function, the brake ramp of the frequency converter is not monitored with respect to safety.

**Example with Category 4/PL e application**

Where the safety control system design requires 2 channels for the STO function to achieve Category 4/PL e, one channel can be implemented by Safe Torque Off T37 (STO) and the other by a contactor, which may be connected in either the frequency converter input or output power circuits and controlled by the safety relay (see *Illustration 2.5*). The contactor must be monitored through an auxiliary guided contact, and connected to the reset input of the safety relay.

**Paralleling of Safe Torque Off input the one safety relay**

Safe Torque Off inputs T37 (STO) may be connected directly, if it is required to control multiple frequency converters from the same control line via one safety relay (see *Illustration 2.6*). Connecting inputs increases the probability of a fault in the unsafe direction, since a fault in one frequency converter might result in all frequency converters becoming enabled. The probability of a fault for T37 is so low, that the resulting probability still meets the requirements for SIL2.

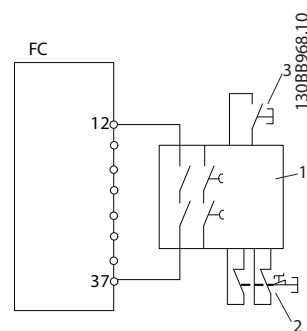

Illustration 2.3 STO Example

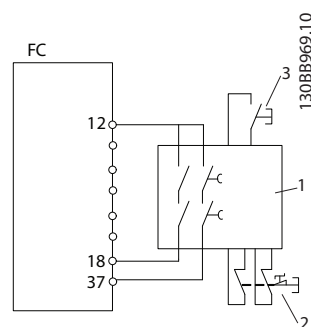

Illustration 2.4 SS1 Example

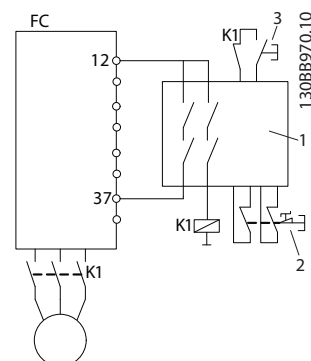

Illustration 2.5 STO Category 4 Example

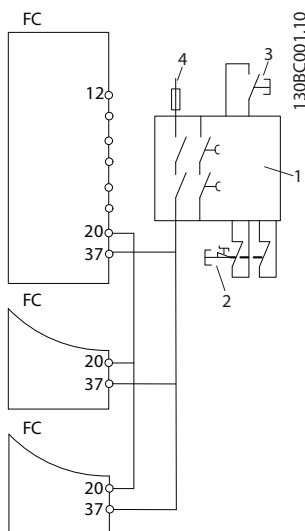

Illustration 2.6 Paralleling of Multiple Frequency Converters Example

1	Safety relay
2	Emergency stop button
3	Reset button
4	24 V DC

Table 2.4 Legend to Illustration 2.3 to Illustration 2.6

**WARNING**

Safe Torque Off activation (i.e. removal of 24 V DC voltage supply to terminal 37) does not provide electrical safety. The Safe Torque Off function itself is therefore not sufficient to implement the Emergency-Off function as defined by EN 60204-1. Emergency-Off requires measures of electrical isolation, e.g. by switching off mains via an additional contactor.

1. Activate the Safe Torque Off function by removing the 24 V DC voltage supply to the terminal 37.
2. After activation of Safe Torque Off (i.e. after the response time), the frequency converter coasts (stops creating a rotational field in the motor). The response time is typically shorter than 10 ms for the complete performance range of the frequency converter.

The frequency converter is guaranteed not to restart creation of a rotational field by an internal fault (in accordance with Cat. 3 PL d acc. EN ISO 13849-1 and SIL 2 acc. EN 62061). After activation of Safe Torque Off, the frequency converter display shows the text Safe Torque Off activated. The associated help text says "Safe Torque Off has been activated. This means that the Safe Torque Off has been activated, or that normal operation has not been resumed yet after Safe Torque Off activation.

**NOTICE**

The requirements of Cat. 3/PL "d" (ISO 13849-1) are only fulfilled while 24 V DC supply to terminal 37 is kept removed or low by a safety device, which itself fulfills Cat. 3/PL "d" (ISO 13849-1). If external forces act on the motor e.g. in case of vertical axis (suspended loads) - and an unwanted movement, for example caused by gravity, could cause a hazard, the motor must not be operated without additional measures for fall protection. E.g. mechanical brakes must be installed additionally.

To resume operation after activation of Safe Torque Off, first reapply 24 V DC voltage to terminal 37 (text Safe Torque Off activated is still displayed), second create a reset signal (via bus, Digital I/O, or [Reset] key on inverter).

By default the Safe Torque Off functions is set to an Unintended Restart Prevention behaviour. This means, in order to terminate Safe Torque Off and resume normal operation, first the 24 V DC must be reapplied to Terminal 37. Subsequently, give a reset signal (via Bus, Digital I/O, or [Reset] key).

The Safe Torque Off function can be set to an Automatic Restart Behaviour by setting the value of 5-19 Terminal 37 Safe Stop from default value [1] to value [3]. If a MCB 112 Option is connected to the frequency converter, then Automatic Restart Behaviour is set by values [7] and [8]. Automatic Restart means that Safe Torque Off is terminated, and normal operation is resumed, as soon as the 24 V DC is applied to Terminal 37, no reset signal is required.

**WARNING**

Automatic Restart Behaviour is only allowed in one of the 2 situations:

1. The Unintended Restart Prevention is implemented by other parts of the Safe Torque Off installation.
2. A presence in the dangerous zone can be physically excluded when Safe Torque Off is not activated. In particular, paragraph 5.3.2.5 of ISO 12100-2 2003 must be observed

2.6.2 Installation of External Safety Device in Combination with MCB 112

If the Ex-certified thermistor module MCB 112, which uses Terminal 37 as its safety-related switch-off channel, is connected, then the output X44/12 of MCB 112 must be AND-ed with the safety-related sensor (such as emergency stop button, safety-guard switch, etc.) that activates Safe Torque Off. This means that the output to Safe Torque Off terminal 37 is HIGH (24 V) only, if both the signal from

MCB 112 output X44/12 and the signal from the safety-related sensor are HIGH. If at least one of the 2 signals is LOW, the output to Terminal 37 must be LOW, too. The safety device with this AND logic itself must conform to IEC 61508, SIL 2. The connection from the output of the safety device with safe AND logic to Safe Torque Off terminal 37 must be short-circuit protected. See *Illustration 2.7*.

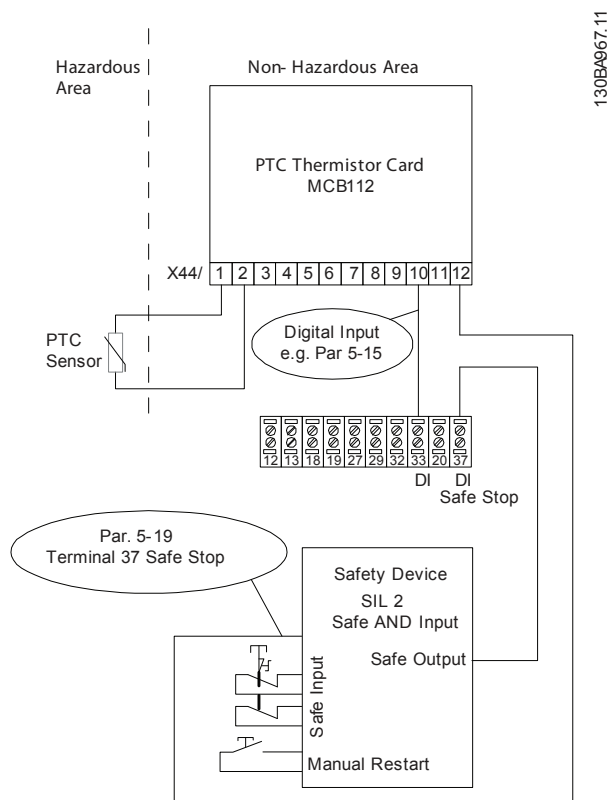

130BA967.11

**Illustration 2.7** Illustration of the essential aspects for installing a combination of a Safe Torque Off application and a MCB 112 application. The diagram shows a Restart input for the external Safety Device. This means that in this installation 5-19 Terminal 37 Safe Stop might be set to value [7] PTC 1 & Relay W or [8] [8] PTC 1 & Relay A/W. Refer to MCB 112 operating instructions for further details.

**Parameter settings for external safety device in combination with MCB112**

If MCB 112 is connected, then additional selections ([4] PTC 1 Alarm to [9] PTC 1 & Relay W/A) become possible for 5-19 Terminal 37 Safe Stop. Selections [1] Safe Torque Off Alarm and [3] Safe Torque Off Warning are still available but are not to be used as these are for installations without MCB 112 or any external safety devices. If [1] Safe Torque Off Alarm or [3] Safe Torque Off Warning should be selected by mistake and MCB 112 is triggered, then the frequency converter reacts with an alarm "Dangerous Failure [A72]" and coasts the frequency converter safely, without Automatic Restart. Selections [4] PTC 1 Alarm and [5] PTC 1

Warning are not to be selected when an external safety device is used. These selections are for when only MCB 112 uses the Safe Torque Off. If selection [4] PTC 1 Alarm or [5] PTC 1 Warning is selected by mistake and the external safety device triggers Safe Torque Off, the frequency converter issues an alarm "Dangerous Failure [A72]" and coasts the frequency converter safely, without Automatic Restart.

Selections [6] PTC 1 & Relay A to [9] PTC 1 & Relay W/A must be selected for the combination of external safety device and MCB 112.

**NOTICE**

Note that selections [7] PTC 1 & Relay W and [8] PTC 1 & Relay A/W open up for Automatic restart when the external safety device is de-activated again.

This is only allowed in the following cases:

- The unintended restart prevention is implemented by other parts of the Safe Torque Off installation.
- A presence in the dangerous zone can be physically excluded when Safe Torque Off is not activated. In particular, paragraph 5.3.2.5 of ISO 12100-2 2003 must be observed.

See MCB 112 operating instructions for further information.

**2.6.3 Safe Torque Off Commissioning Test**

After installation and before first operation, perform a commissioning test of an installation or application making use of Safe Torque Off.

Moreover, perform the test after each modification of the installation or application, which the Safe Torque Off is part of.

**NOTICE**

A passed commissioning test is mandatory after first installation and after each change to the safety installation.

The commissioning test (select one of cases 1 or 2 as applicable):

**Case 1: Restart prevention for Safe Torque Off is required (i.e. Safe Torque Off only where 5-19 Terminal 37 Safe Stop is set to default value [1], or combined Safe Torque Off and MCB112 where 5-19 Terminal 37 Safe Stop is set to [6] or [9]):**

- 1.1 Remove the 24 V DC voltage supply to terminal 37 by the interrupt device while the motor is driven by the FC 102 (i.e. mains supply is not interrupted). The test step is passed if the motor reacts with a coast and the mechanical brake (if connected) is activated, and if an LCP is

mounted, the alarm “Safe Torque Off [A68]” is displayed.

1.2 Send reset signal (via Bus, Digital I/O, or [Reset] key). The test step is passed if the motor remains in the Safe Torque Off state, and the mechanical brake (if connected) remains activated.

1.3 Reapply 24 V DC to terminal 37. The test step is passed if the motor remains in the coasted state, and the mechanical brake (if connected) remains activated.

1.4 Send reset signal (via Bus, Digital I/O, or [Reset] key). The test step is passed if the motor becomes operational again.

The commissioning test is passed if all 4 test steps 1.1, 1.2, 1.3 and 1.4 are passed.

**Case 2: Automatic Restart of Safe Torque Off is wanted and allowed (i.e. Safe Torque Off only where 5-19 Terminal 37 Safe Stop is set to [3], or combined Safe Torque Off and MCB112 where 5-19 Terminal 37 Safe Stop is set to [7] or [8]):**

2.1 Remove the 24 V DC voltage supply to terminal 37 by the interrupt device while the motor is driven by the FC 102 (i.e. mains supply is not interrupted). The test step is passed if the motor reacts with a coast and the mechanical brake (if connected) is activated, and if an LCP is mounted, the warning “Safe Torque Off [W68]” is displayed.

2.2 Reapply 24 V DC to terminal 37.

The test step is passed if the motor becomes operational again. The commissioning test is passed if both test steps 2.1 and 2.2 are passed.

**NOTICE**

See warning on the restart behaviour in chapter 2.6.1 Terminal 37 Safe Torque Off Function

2.7 Advantages

2.7.1 Why use a Frequency Converter for Controlling Fans and Pumps?

A frequency converter takes advantage of the fact that centrifugal fans and pumps follow the laws of proportionality for such fans and pumps. For further information see the text and figure *The Laws of Proportionality*.

2.7.2 The Clear Advantage - Energy Savings

The advantage of using a frequency converter for controlling the speed of fans or pumps lies in the electricity savings.

When comparing with alternative control systems and technologies, a frequency converter is the optimum energy control system for controlling fan and pump systems.

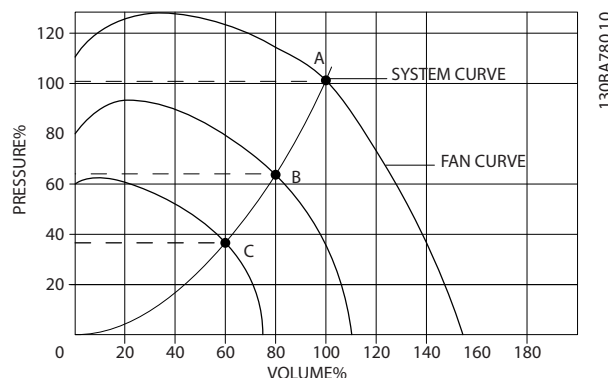

Illustration 2.8 Fan Curves (A, B and C) for Reduced Fan Volumes

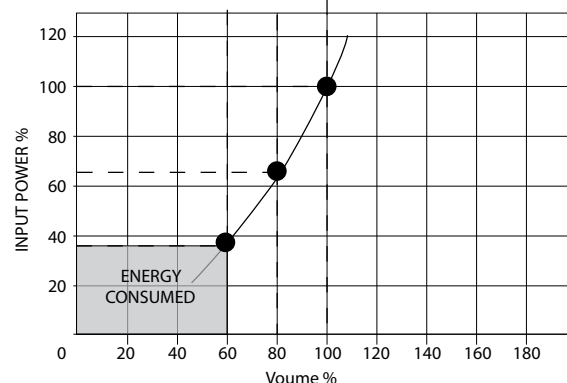
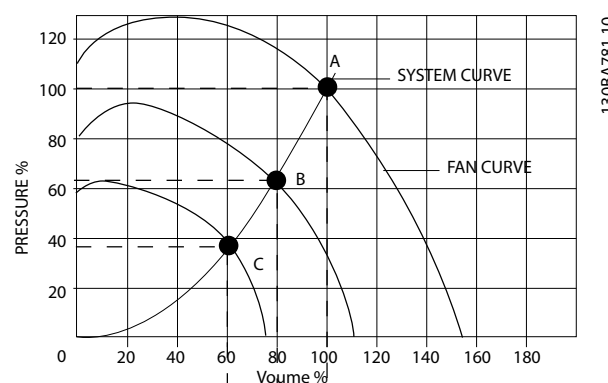

Illustration 2.9 When Using a Frequency Converter to Reduce Fan Capacity to 60% - More Than 50% Energy Savings May Be Obtained in Typical Applications.

2.7.3 Example of Energy Savings

As shown in the figure (the laws of proportionality), the flow is controlled by changing the RPM. By reducing the speed only 20% from the rated speed, the flow is also

reduced by 20%. This is because the flow is directly proportional to the RPM. The consumption of electricity, however, is reduced by 50%.

If the system in question only needs to be able to supply a flow that corresponds to 100% a few days in a year, while the average is below 80% of the rated flow for the remainder of the year, the amount of energy saved is even more than 50%.

The laws of proportionality	
<i>Illustration 2.10</i> describes the dependence of flow, pressure and power consumption on RPM.	
Q = Flow	P = Power
Q <sub>1</sub> = Rated flow	P <sub>1</sub> = Rated power
Q <sub>2</sub> = Reduced flow	P <sub>2</sub> = Reduced power
H = Pressure	n = Speed regulation
H <sub>1</sub> = Rated pressure	n <sub>1</sub> = Rated speed
H <sub>2</sub> = Reduced pressure	n <sub>2</sub> = Reduced speed

Table 2.5 Abbreviations Used in Equation

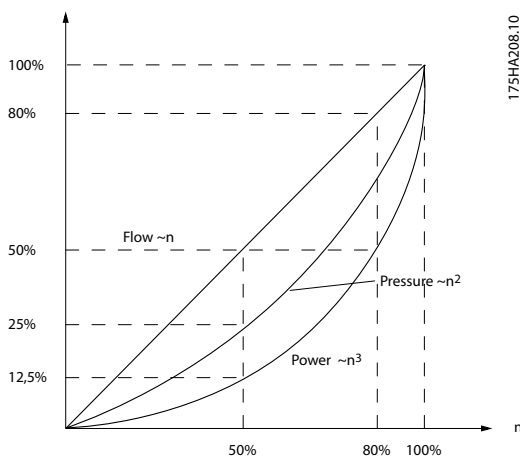

Illustration 2.10 The Dependence of Flow, Pressure and Power Consumption on RPM

$$\text{Flow: } \frac{Q_1}{Q_2} = \frac{n_1}{n_2}$$

$$\text{Pressure: } \frac{H_1}{H_2} = \left(\frac{n_1}{n_2}\right)^2$$

$$\text{Power: } \frac{P_1}{P_2} = \left(\frac{n_1}{n_2}\right)^3$$

### 2.7.4 Comparison of Energy Savings

The Danfoss frequency converter solution offers major savings compared with traditional energy saving solutions. This is because the frequency converter is able to control fan speed according to thermal load on the system and the fact that the frequency converter has a built-in facility that enables the frequency converter to function as a Building Management System, BMS.

*Illustration 2.12* shows typical energy savings obtainable with 3 well-known solutions when fan volume is reduced to i.e. 60%.

*Illustration 2.12* shows more than 50% energy savings can be achieved in typical applications.

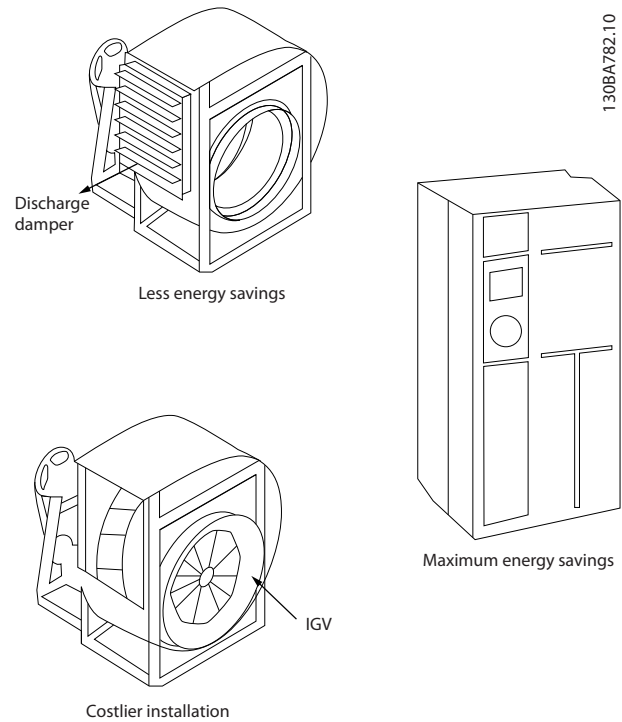

Illustration 2.11 The 3 Common Energy Saving Systems

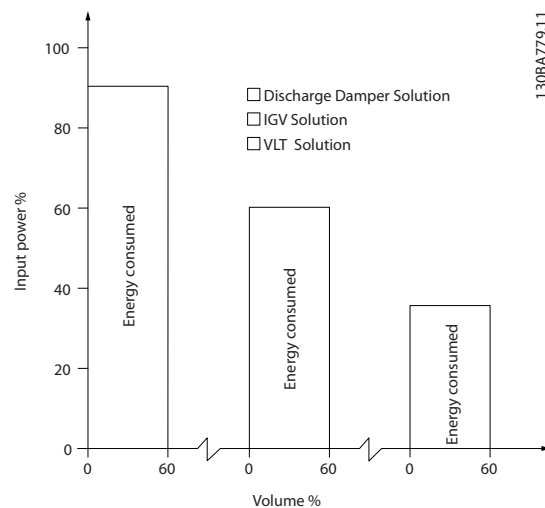

Illustration 2.12 Discharge dampers reduce power consumption somewhat. Inlet Guide Vans offer a 40% reduction but are expensive to install. The Danfoss frequency converter solution reduces energy consumption with more than 50% and is easy to install.



### 2.7.5 Example with Varying Flow over 1 Year

The example below is calculated on the basis of pump characteristics obtained from a pump datasheet. The result obtained shows energy savings in excess of 50% at the given flow distribution over a year. The pay back period depends on the price per kWh and price of frequency converter. In this example it is less than a year when compared with valves and constant speed.

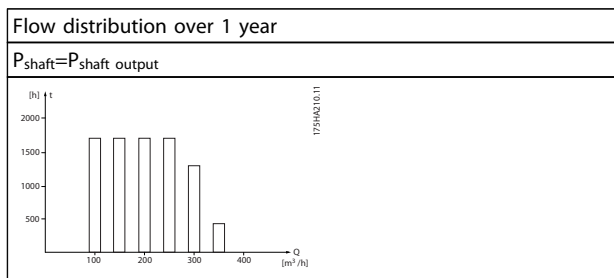

Table 2.6 Energy Savings

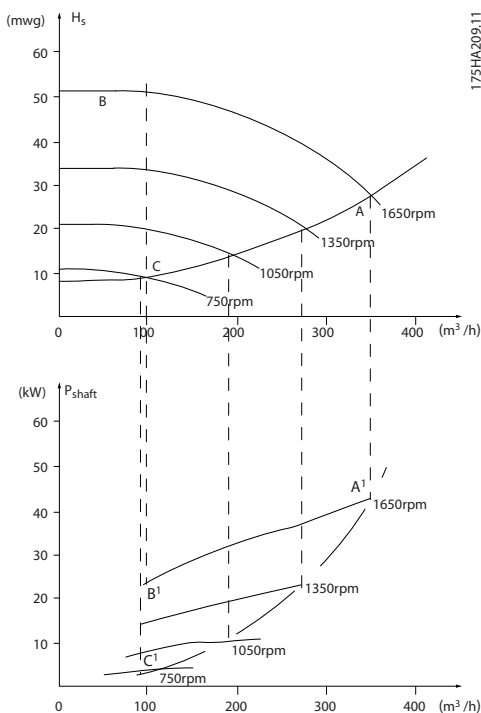

Illustration 2.13 Example with Varying Flow

m³/h	Distri- bution		Valve regulation		Frequency converter control	
	%	Hours	Power	Consumption	Power	Consumption
			A <sub>1</sub> -B <sub>1</sub>	kWh	A <sub>1</sub> -C <sub>1</sub>	kWh
350	5	438	42,5	18.615	42,5	18.615
300	15	1314	38,5	50.589	29,0	38.106
250	20	1752	35,0	61.320	18,5	32.412
200	20	1752	31,5	55.188	11,5	20.148
150	20	1752	28,0	49.056	6,5	11.388
100	20	1752	23,0	40.296	3,5	6.132
Σ	100	8760		275.064		26.801

Table 2.7 Consumption

### 2.7.6 Better Control

If a frequency converter is used for controlling the flow or pressure of a system, improved control is obtained. A frequency converter can vary the speed of the fan or pump, thereby obtaining variable control of flow and pressure.

Furthermore, a frequency converter can quickly adapt the speed of the fan or pump to new flow or pressure conditions in the system.

Simple control of process (Flow, Level or Pressure) utilising the built-in PID control.

### 2.7.7 Cos φ Compensation

Generally speaking, the VLT® HVAC Drive has a cos φ of 1 and provides power factor correction for the cos φ of the motor, which means that there is no need to make allowance for the cos φ of the motor when sizing the power factor correction unit.

### 2.7.8 Star/Delta Starter or Soft-starter not Required

When larger motors are started, it is necessary in many countries to use equipment that limits the start-up current. In more traditional systems, a star/delta starter or soft-starter is widely used. Such motor starters are not required if a frequency converter is used.

As illustrated in *Illustration 2.14*, a frequency converter does not consume more than rated current.



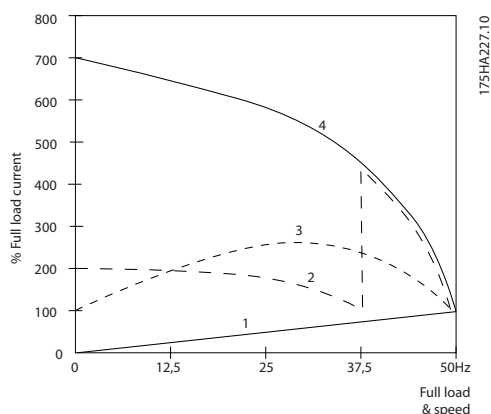

Illustration 2.14 A Frequency Converter Does Not Consume More Than Rated Current

1	VLT® HVAC Drive
2	Star/delta starter
3	Soft-starter
4	Start directly on mains

Table 2.8 Legend to Illustration 2.14

### 2.7.9 Using a Frequency Converter Saves Money

The example on the following page shows that a lot of equipment is not required when a frequency converter is used. It is possible to calculate the cost of installing the 2 different systems. In the example on the following page, the 2 systems can be established at roughly the same price.

### 2.7.10 Without a Frequency Converter

D.D.C.	=	Direct Digital Control	E.M.S.	=	Energy Management system
V.A.V.	=	Variable Air Volume			
Sensor P	=	Pressure	Sensor T	=	Temperature

Table 2.9 Abbreviations used in Illustration 2.15 and Illustration 2.16

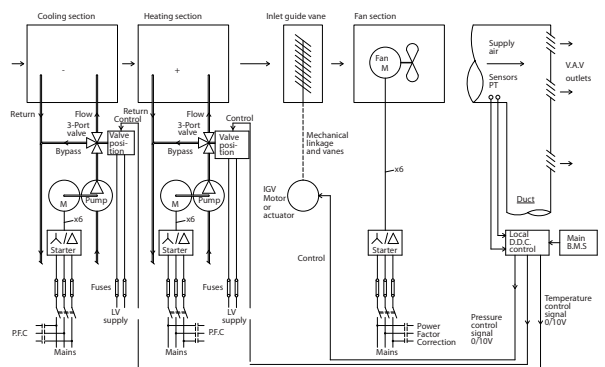

Illustration 2.15 Traditional Fan System

### 2.7.11 With a Frequency Converter

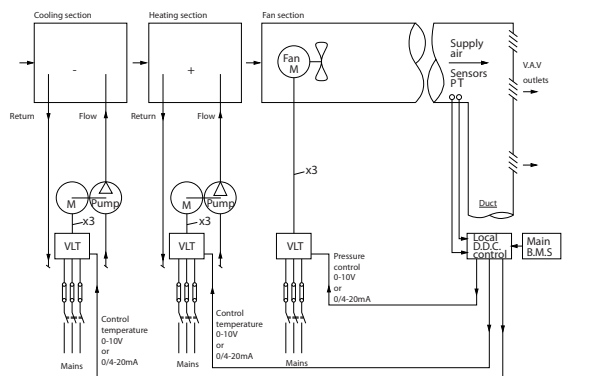

Illustration 2.16 Fan System Controlled by Frequency Converters.

## 2.7.12 Application Examples

The next pages give typical examples of applications within HVAC.

For further information about a given application, ask a Danfoss supplier for an information sheet that gives a full description of the application.

### Variable Air Volume

*Ask for The Drive to...Improving Variable Air Volume Ventilation Systems MN.60.A1.02*

### Constant Air Volume

*Ask for The Drive to...Improving Constant Air Volume Ventilation Systems MN.60.B1.02*

### Cooling Tower Fan

*Ask for The Drive to...Improving fan control on cooling towers MN.60.C1.02*

### Condenser pumps

*Ask for The Drive to...Improving condenser water pumping systems MN.60.F1.02*

### Primary pumps

*Ask for The Drive to...Improve your primary pumping in primay/secondary pumping systems MN.60.D1.02*

### Secondary pumps

*Ask for The Drive to...Improve your secondary pumping in primay/secondary pumping systems MN.60.E1.02*

### 2.7.13 Variable Air Volume

VAV or Variable Air Volume systems, are used to control both the ventilation and temperature to satisfy the requirements of a building. Central VAV systems are considered to be the most energy efficient method to air condition buildings. By designing central systems instead of distributed systems, a greater efficiency can be obtained.

The efficiency comes from utilising larger fans and larger chillers, which have much higher efficiencies than small motors and distributed air-cooled chillers. Savings are also seen from the decreased maintenance requirements.

### 2.7.14 The VLT Solution

While dampers and IGVs work to maintain a constant pressure in the ductwork, a solution saves much more energy and reduces the complexity of the installation. Instead of creating an artificial pressure drop or causing a decrease in fan efficiency, the decreases the speed of the fan to provide the flow and pressure required by the system.

Centrifugal devices such as fans behave according to the centrifugal laws. This means the fans decrease the pressure and flow they produce as their speed is reduced. Their power consumption is thereby significantly reduced.

The return fan is frequently controlled to maintain a fixed difference in airflow between the supply and return. The advanced PID controller of the HVAC can be used to eliminate the need for additional controllers.

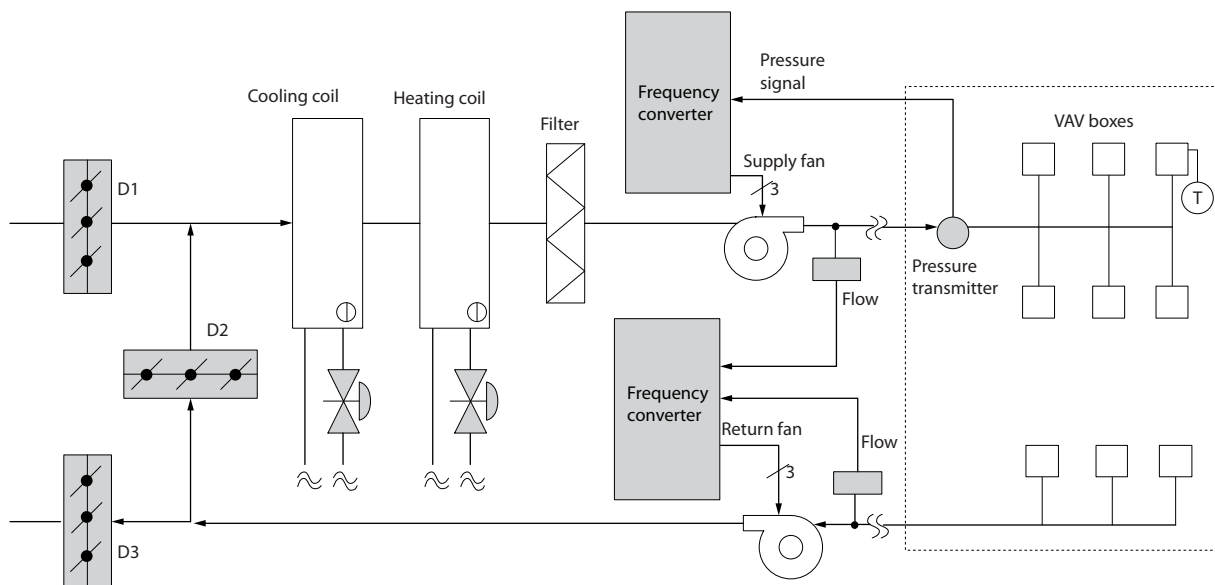

130BB45.10

Illustration 2.17 The VLT Solution

### 2.7.15 Constant Air Volume

2

CAV, or Constant Air Volume systems are central ventilation systems usually used to supply large common zones with the minimum amounts of fresh tempered air. They preceded VAV systems and therefore are found in older multi-zoned commercial buildings as well. These systems preheat amounts of fresh air utilising Air Handling Units (AHUs) with a heating coil, and many are also used to air condition buildings and have a cooling coil. Fan coil units are frequently used to assist in the heating and cooling requirements in the individual zones.

### 2.7.16 The VLT Solution

With a frequency converter, significant energy savings can be obtained while maintaining decent control of the building. Temperature sensors or CO<sub>2</sub> sensors can be used as feedback signals to frequency converters. Whether controlling temperature, air quality, or both, a CAV system can be controlled to operate based on actual building conditions. As the number of people in the controlled area decreases, the need for fresh air decreases. The CO<sub>2</sub> sensor detects lower levels and decreases the supply fans speed. The return fan modulates to maintain a static pressure setpoint or fixed difference between the supply and return air flows.

With temperature control, especially used in air conditioning systems, as the outside temperature varies as well as the number of people in the controlled zone changes, different cooling requirements exist. As the temperature decreases below the set-point, the supply fan can decrease its speed. The return fan modulates to maintain a static pressure set-point. By decreasing the air flow, energy used to heat or cool the fresh air is also reduced, adding further savings.

Several features of the Danfoss HVAC dedicated frequency converter can be utilised to improve the performance of a CAV system. One concern of controlling a ventilation system is poor air quality. The programmable minimum frequency can be set to maintain a minimum amount of supply air regardless of the feedback or reference signal. The frequency converter also includes a 3-zone, 3-setpoint PID controller which allows monitoring both temperature and air quality. Even if the temperature requirement is satisfied, the frequency converter will maintain enough supply air to satisfy the air quality sensor. The frequency converter is capable of monitoring and comparing 2 feedback signals to control the return fan by maintaining a fixed differential air flow between the supply and return ducts as well.

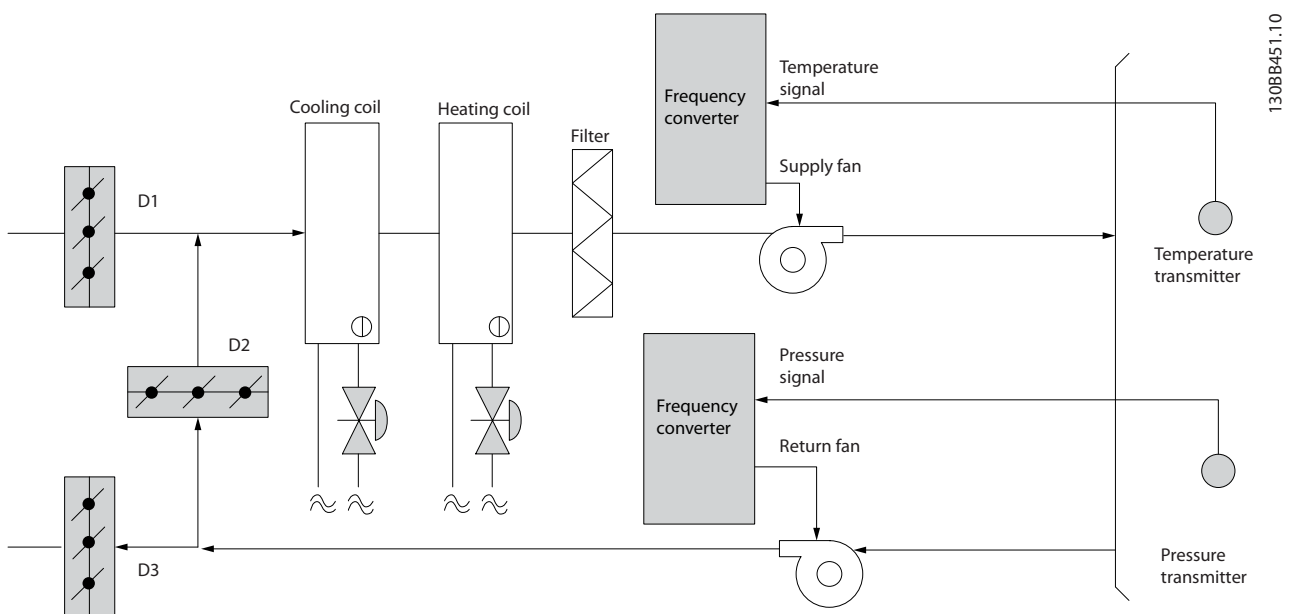

Illustration 2.18 The VLT Solution

### 2.7.17 Cooling Tower Fan

Cooling Tower Fans are used to cool condenser water in water cooled chiller systems. Water cooled chillers provide the most efficient means of creating chilled water. They are as much as 20% more efficient than air cooled chillers. Depending on climate, cooling towers are often the most energy efficient method of cooling the condenser water from chillers.

They cool the condenser water by evaporation.

The condenser water is sprayed into the cooling tower onto the cooling towers "fill" to increase its surface area. The tower fan blows air through the fill and sprayed water to aid in the evaporation. Evaporation removes energy from the water dropping its temperature. The cooled water collects in the cooling towers basin where it is pumped back into the chillers condenser and the cycle is repeated.

### 2.7.18 The VLT Solution

With a frequency converter, the cooling towers fans can be controlled to the required speed to maintain the condenser water temperature. The frequency converters can also be used to turn the fan on and off as needed.

Several features of the Danfoss HVAC dedicated frequency converter, the HVAC frequency converter can be utilised to improve the performance of a cooling tower fans application. As the cooling tower fans drop below a certain speed, the effect the fan has on cooling the water becomes small. Also, when utilising a gear-box to frequency control the tower fan, a minimum speed of 40-50% may be required.

The customer programmable minimum frequency setting is available to maintain this minimum frequency even as the feedback or speed reference calls for lower speeds.

Also as a standard feature, program the frequency converter to enter a "sleep" mode and stop the fan until a higher speed is required. Additionally, some cooling tower fans have undesirable frequencies that may cause vibrations. These frequencies can easily be avoided by programming the bypass frequency ranges in the frequency converter.

2

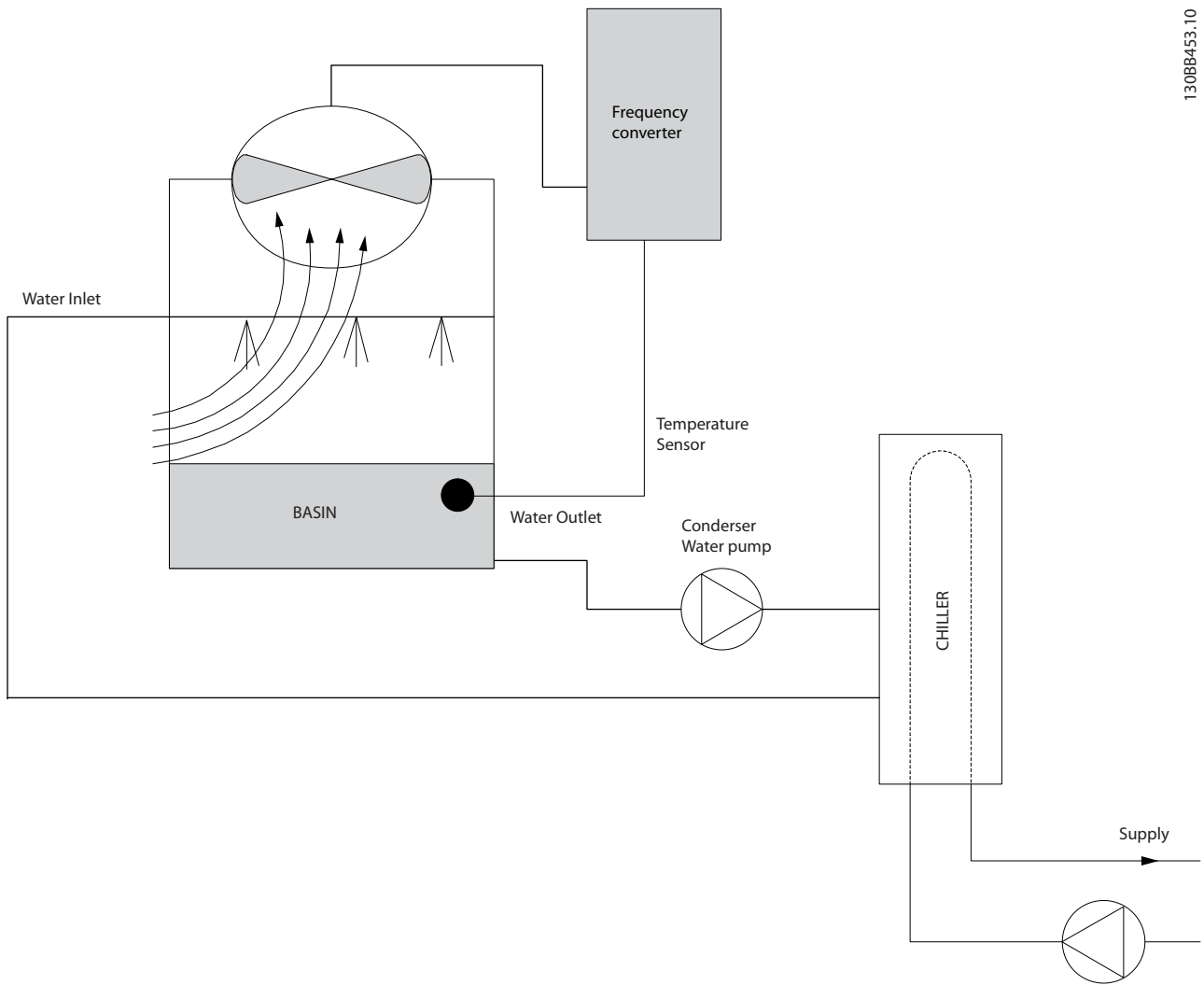

130BB453.10

Illustration 2.19 The VLT Solution

### 2.7.19 Condenser Pumps

Condenser Water pumps are primarily used to circulate water through the condenser section of water cooled chillers and their associated cooling tower. The condenser water absorbs the heat from the chiller's condenser section and releases it into the atmosphere in the cooling tower. These systems are used to provide the most efficient means of creating chilled water, they are as much as 20% more efficient than air cooled chillers.

### 2.7.20 The VLT Solution

Frequency converters can be added to condenser water pumps instead of balancing the pumps with a throttling valve or trimming the pump impeller.

Using a frequency converter instead of a throttling valve simply saves the energy that would have been absorbed by the valve. This can amount to savings of 15-20% or more. Trimming the pump impeller is irreversible, thus if the conditions change and higher flow is required the impeller must be replaced.

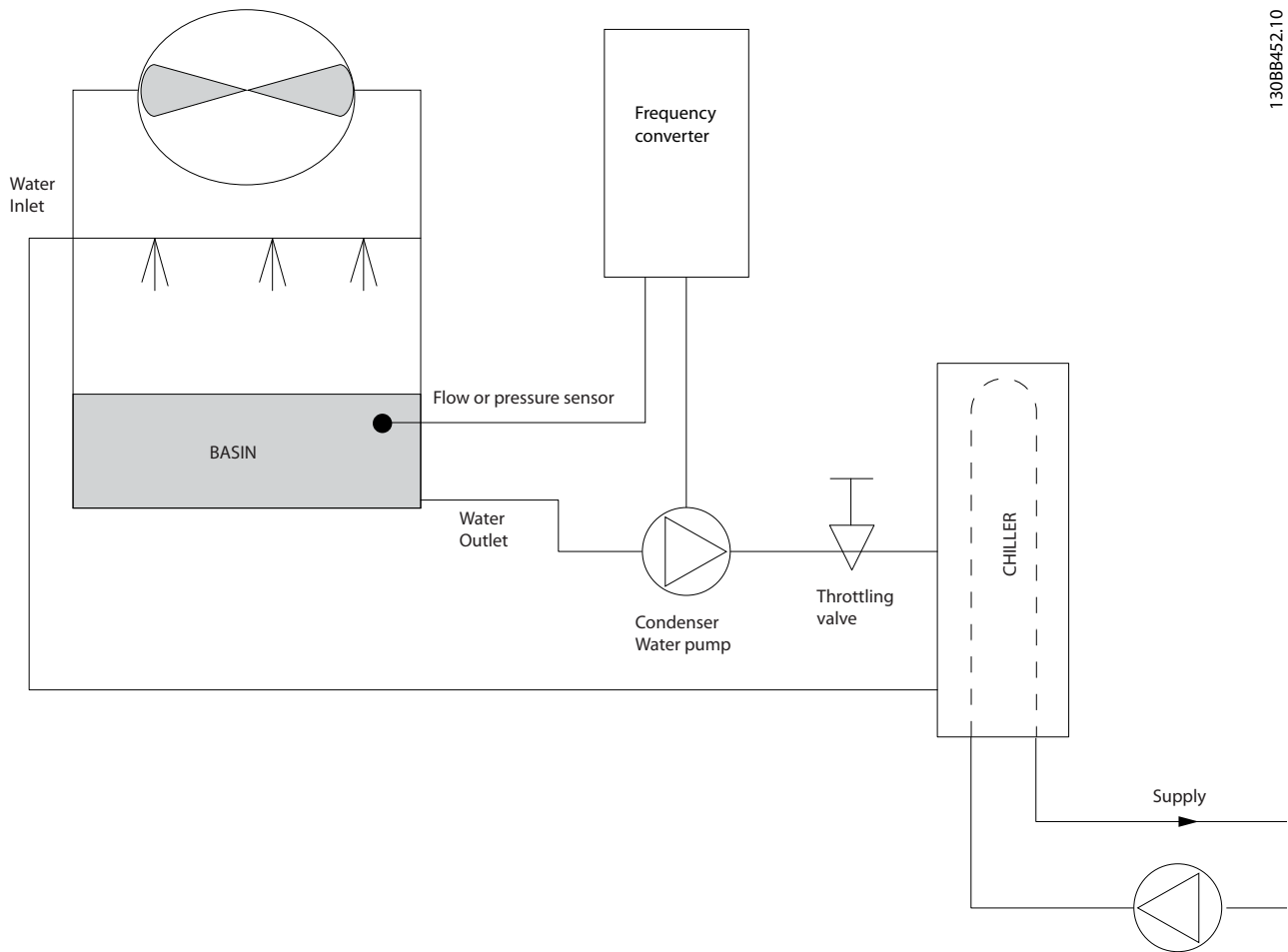

Illustration 2.20 The VLT Solution

### 2.7.21 Primary Pumps

Primary pumps in a primary/secondary pumping system can be used to maintain a constant flow through devices that encounter operation or control difficulties when exposed to variable flow. The primary/secondary pumping technique decouples the “primary” production loop from the “secondary” distribution loop. This allows devices such as chillers to obtain constant design flow and operate properly, while allowing the rest of the system to vary in flow.

As the evaporator flow rate decreases in a chiller, the chilled water begins to become over-chilled. As this happens, the chiller attempts to decrease its cooling capacity. If the flow rate drops far enough, or too quickly, the chiller cannot shed its load sufficiently and the chiller’s low evaporator temperature safety trips the chiller requiring a manual reset. This situation is common in large installations especially when 2 or more chillers in parallel are installed if primary/secondary pumping is not utilised.

### 2.7.22 The VLT Solution

Depending on the size of the system and the size of the primary loop, the energy consumption of the primary loop can become substantial.

A frequency converter can be added to the primary system, to replace the throttling valve and/or trimming of the impellers, leading to reduced operating expenses. 2 control methods are common:

The first method uses a flow meter. Because the desired flow rate is known and is constant, a flow meter installed at the discharge of each chiller, can be used to control the pump directly. Using the built-in PID controller, the frequency converter always maintains the appropriate flow rate, even compensating for the changing resistance in the primary piping loop as chillers and their pumps are staged on and off.

The other method is local speed determination. The operator simply decreases the output frequency until the design flow rate is achieved.

Using a frequency converter to decrease the pump speed is very similar to trimming the pump impeller, except it does not require any labour and the pump efficiency remains higher. The balancing contractor simply decreases the speed of the pump until the proper flow rate is achieved and leaves the speed fixed. The pump operates at this speed any time the chiller is staged on. Because the primary loop does not have control valves or other devices that can cause the system curve to change, and the variance due to staging pumps and chillers on and off is usually small, this fixed speed remains appropriate. In the event the flow rate needs to be increased later in the systems life, the frequency converter can simply increase the pump speed instead of requiring a new pump impeller.



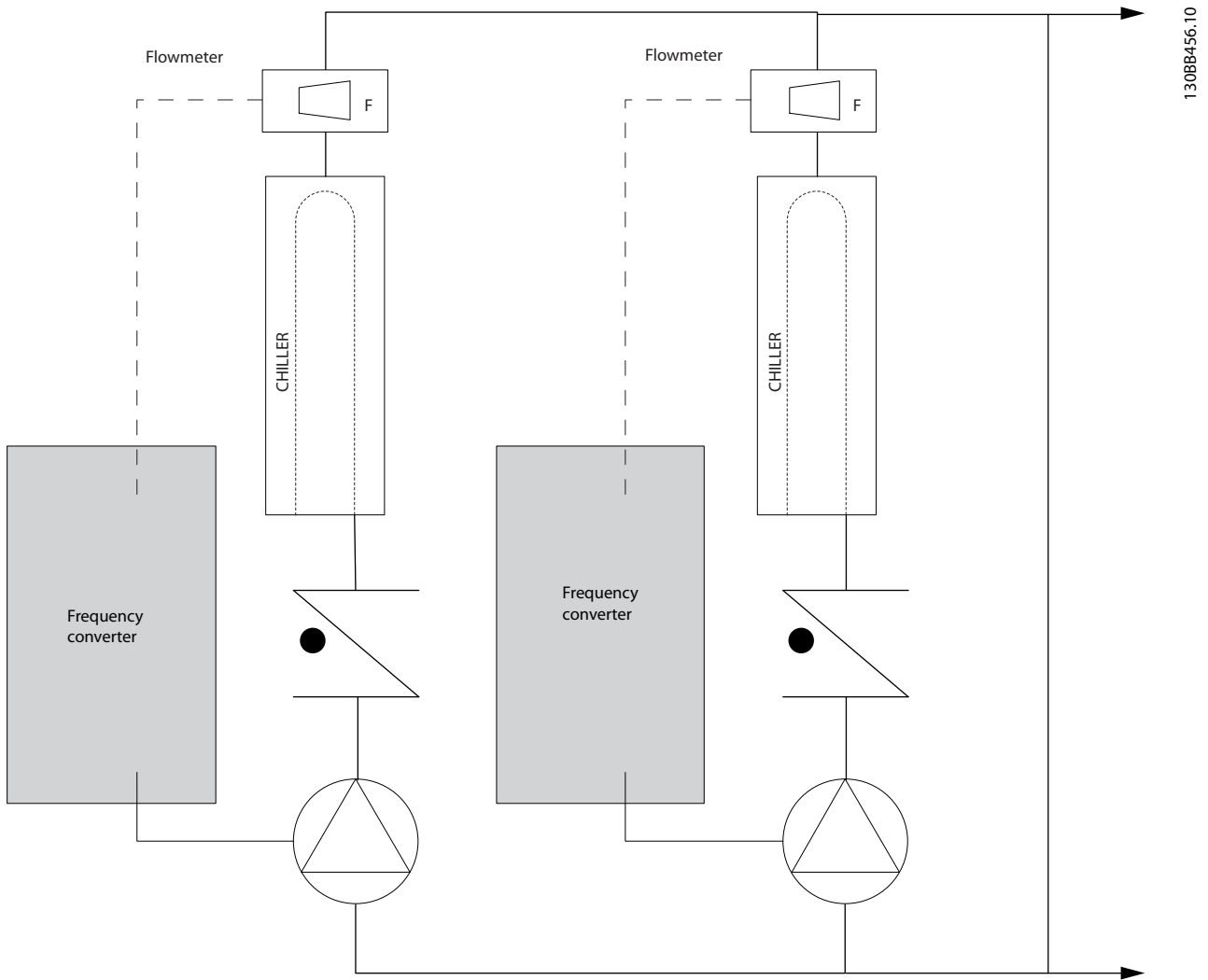

130BB456.10

2

Illustration 2.21 The VLT Solution

2

### 2.7.23 Secondary Pumps

Secondary pumps in a primary/secondary chilled water pumping system are used to distribute the chilled water to the loads from the primary production loop. The primary/secondary pumping system is used to hydraulically de-couple one piping loop from another. In this case, the primary pump is used to maintain a constant flow through the chillers while allowing the secondary pumps to vary in flow, increase control and save energy.

If the primary/secondary design concept is not used, and a variable volume system is designed, when the flow rate drops far enough or too quickly, the chiller cannot shed its load properly. The chiller's low evaporator temperature safety then trips the chiller requiring a manual reset. This situation is common in large installations especially when 2 or more chillers in parallel are installed.

### 2.7.24 The VLT Solution

While the primary-secondary system with 2-way valves improves energy savings and eases system control problems, the true energy savings and control potential is realised by adding frequency converters.

With the proper sensor location, the addition of frequency converters allows the pumps to vary their speed to follow the system curve instead of the pump curve.

This results in the elimination of wasted energy and eliminates most of the over-pressurisation, 2-way valves can be subjected too.

As the monitored loads are reached, the 2-way valves close down. This increases the differential pressure measured across the load and 2-way valve. As this differential pressure starts to rise, the pump is slowed to maintain the control head also called setpoint value. This setpoint value is calculated by summing up the pressure drop of the load and 2-way valve under design conditions.

Note that when running multiple pumps in parallel, they must run at the same speed to maximize energy savings, either with individual dedicated drives or one running multiple pumps in parallel.

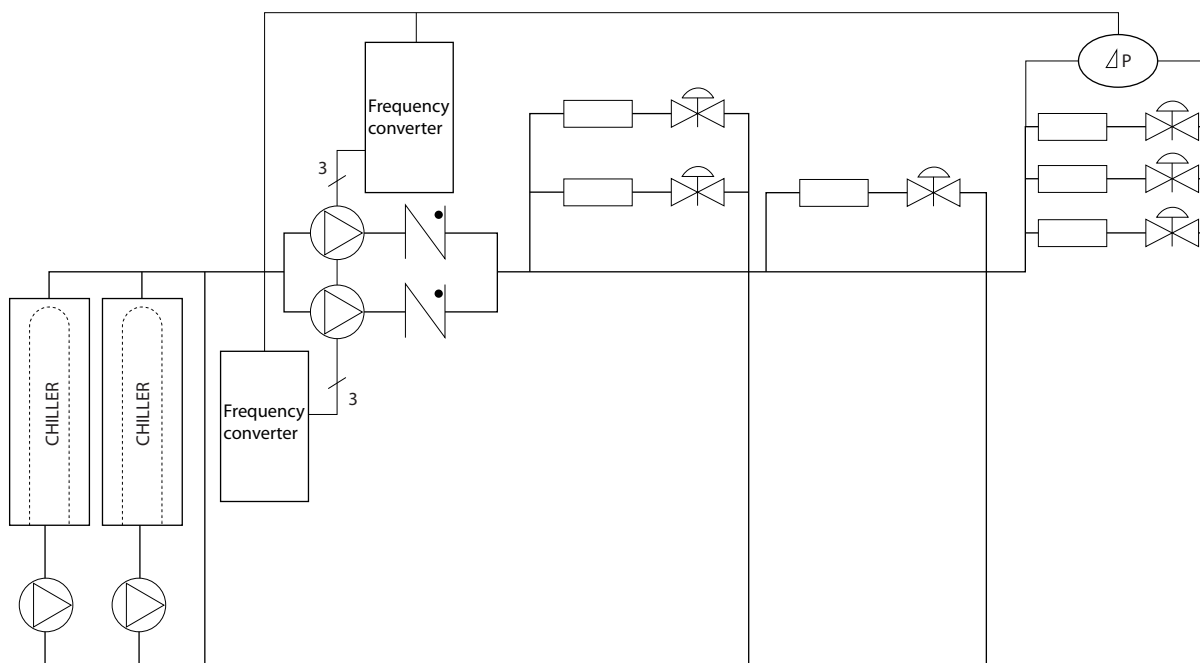

13088454.10

Illustration 2.22 The VLT Solution

## 2.8 Control Structures

### 2.8.1 Control Principle

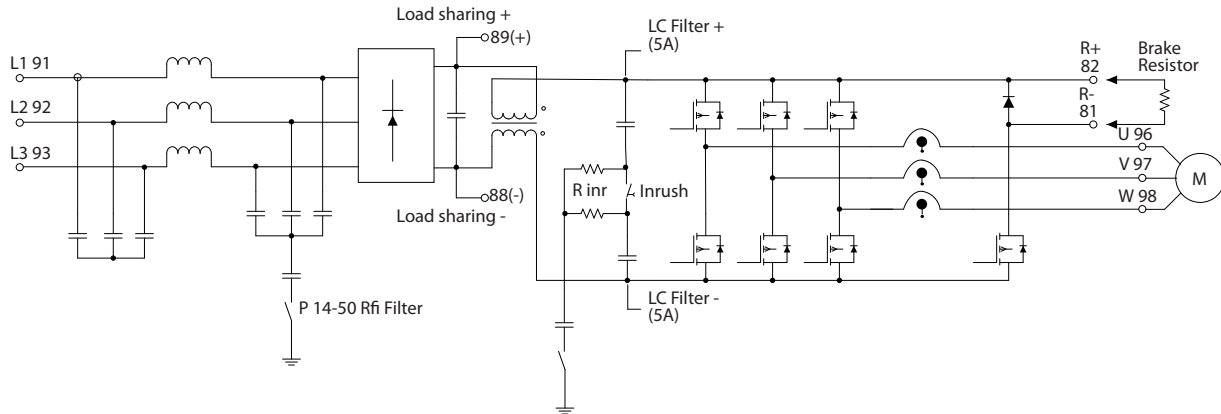

130BA193.14

Illustration 2.23 Control Structures

The frequency converter is a high-performance unit for demanding applications. It can handle various kinds of motor control principles such as U/f special motor mode and VVC<sup>plus</sup> and can handle normal squirrel cage asynchronous motors. Short circuit behavior on this frequency converter depends on the 3 current transducers in the motor phases.

Select between open loop and closed loop in *1-00 Configuration Mode*.

### 2.8.2 Control Structure Open Loop

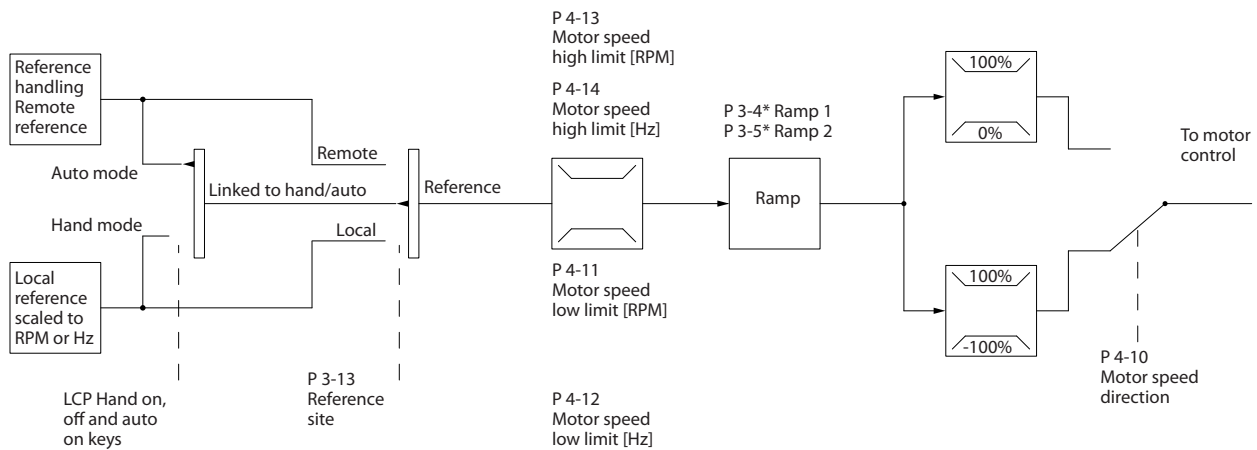

130BB153.10

Illustration 2.24 Open Loop Structure

In the configuration shown in *Illustration 2.24*, *1-00 Configuration Mode* is set to [0] *Open loop*. The resulting reference from the reference handling system or the local reference is received and fed through the ramp limitation and speed limitation before being sent to the motor control.

The output from the motor control is then limited by the maximum frequency limit.

### 2.8.3 PM/EC+ Motor Control

The Danfoss EC+ concept provides the possibility for using high efficient PM motors in IEC standard enclosure types operated by Danfoss frequency converters.

The commissioning procedure is comparable to the existing one for asynchronous (induction) motors by utilising the Danfoss VVC<sup>plus</sup> PM control strategy.

Customer advantages:

- Free choice of motor technology (permanent magnet or induction motor)
- Installation and operation as known for induction motors
- Manufacturer independent when choosing system components (e.g. motors)
- Best system efficiency by choosing best components
- Possible retrofit of existing installations
- Power range: 1.1–22 kW

Current limitations:

- Currently only supported up to 22 kW
- Currently limited to non salient type PM motors
- LC filters not supported together with PM motors
- Over Voltage Control algorithm is not supported with PM motors
- Kinetic back-up algorithm is not supported with PM motors
- AMA algorithm is not supported with PM motors
- No missing motorphase detection
- No stall detection
- No ETR function

### 2.8.4 Sizing of Frequency Converter and PM motor

The low motor inductances of PM motors can cause current ripples in the frequency converter.

To select the right frequency converter for a given PM motor, ensure that:

- The frequency converter can deliver the required power and current in all operating conditions.
- The power rating of the frequency converter is equal to or higher than the power rating of the motor.
- Size the frequency converter for a constant 100% operating load with sufficient safety margin.

The current (A) and the typical power rating (kW) for a PM motor can be found in *chapter 9.1 Mains Supply Tables* for different voltages.

#### Sizing examples for nominal power rating

##### Example 1

- PM motor size: 1.5 kW / 2.9 A
- Mains: 3 x 400 V

Frequency Converter	Typical [kW]	Typical [hp] at 460V	Continuous [A] (3x380-440 V)	Intermittent [A] (3x380-440V)	Continuous [A] (3x441-480 V)	Intermittent [A] (3x441-480V)
P1K1	1.1	1.5	3.0	3.3	2.7	3.0
P1K5	1.5	2.0	4.1	4.5	3.4	3.7

Table 2.10 Sizing Data for 1.1 and 1.5 kW Frequency Converters

The current rating of the PM motor (2.9 A) matches the current rating of both the 1.1 kW frequency converter (3 A @ 400 V) and the 1.5 kW frequency converter (4.1 A @ 400 V). However, since the power rating of the motor is 1.5 kW, the 1.5 kW frequency converter is the correct choice.

	Motor	Frequency Converter 1.5 kW
Power	1.5 kW	1.5 kW
Current	2.9 A	4.1 A @ 400V

Table 2.11 Correctly Sized Frequency Converter

##### Example 2

- PM motor size: 5.5 kW / 12.5 A
- Mains: 3 x 400 V

Frequency Converter	Typical [kW]	Typical [hp] at 460V	Continuous [A] (3x380-440 V)	Intermittent [A] (3x380-440V)	Continuous [A] (3x441-480 V)	Intermittent [A] (3x441-480V)
P4K0	4.0	5.0	10.0	11.0	8.2	9.0
P5K5	5.5	7.5	13.0	14.3	11.0	12.1

Table 2.12 Sizing Data for 4.0 and 5.5 kW Frequency Converters

The current rating of the PM motor (12.5 A) matches the current rating of the 5.5 kW frequency converter (13 A @ 400 V), not the current rating of the 4.0 kW frequency converter (10 A @ 400 V). Since the power rating of the motor is 5.5 kW, the 5.5 kW frequency converter is the correct choice.

	Motor	Frequency Converter 5.5 kW
Power	5.5 kW	5.5 kW
Current	12.5 A	13 A @ 400V

Table 2.13 Correctly Sized Frequency Converter

### 2.8.5 Local (Hand On) and Remote (Auto On) Control

The frequency converter can be operated manually via the local control panel (LCP) or remotely via analog/digital inputs or serial bus.

If allowed in 0-40 [Hand on] Key on LCP, 0-41 [Off] Key on LCP, 0-42 [Auto on] Key on LCP, and 0-43 [Reset] Key on LCP, it is possible to start and stop the frequency converter by LCP using the [Hand On] and [Off] keys. Alarms can be reset via the [Reset] key. After pressing [Hand On], the frequency converter goes into Hand Mode and follows (as default) the local reference set by using [▲] and [▼].

After pressing [Auto On], the frequency converter goes into Auto mode and follows (as default) the remote reference. In this mode, it is possible to control the frequency converter via the digital inputs and various serial interfaces (RS-485, USB, or an optional fieldbus). See more about starting, stopping, changing ramps and parameter set-ups etc. in parameter group 5-1\* *Digital Inputs* or parameter group 8-5\* *Serial Communication*.

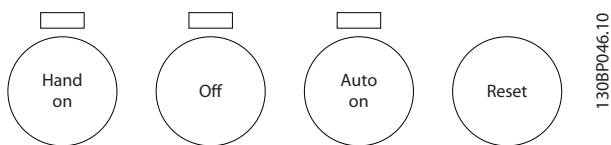

Illustration 2.25 Operation Keys

Hand Off Auto LCP Keys	3-13 Reference Site	Active Reference
Hand	Linked to Hand/ Auto	Local
Hand ⇒ Off	Linked to Hand/ Auto	Local
Auto	Linked to Hand/ Auto	Remote
Auto ⇒ Off	Linked to Hand/ Auto	Remote
All keys	Local	Local
All keys	Remote	Remote

Table 2.14 Conditions for Either Local or Remote Reference

Table 2.14 shows under which conditions either the local reference or the remote reference is active. One of them is always active, but both cannot be active at the same time.

Local reference forces the configuration mode to open loop, independent on the setting of 1-00 *Configuration Mode*.

Local reference is restored at power-down.

### 2.8.6 Control Structure Closed Loop

The internal controller allows the frequency converter to become an integral part of the controlled system. The frequency converter receives a feedback signal from a sensor in the system. It then compares this feedback to a setpoint reference value and determines the error, if any, between these 2 signals. It then adjusts the speed of the motor to correct this error.

For example, consider a pump application where the speed of a pump is to be controlled so that the static pressure in a pipe is constant. The desired static pressure value is supplied to the frequency converter as the setpoint reference. A static pressure sensor measures the actual static pressure in the pipe and supplies this to the frequency converter as a feedback signal. If the feedback signal is greater than the set-point reference, the frequency converter slows down to reduce the pressure. In a similar way, if the pipe pressure is lower than the setpoint reference, the frequency converter automatically speeds up to increase the pressure provided by the pump.

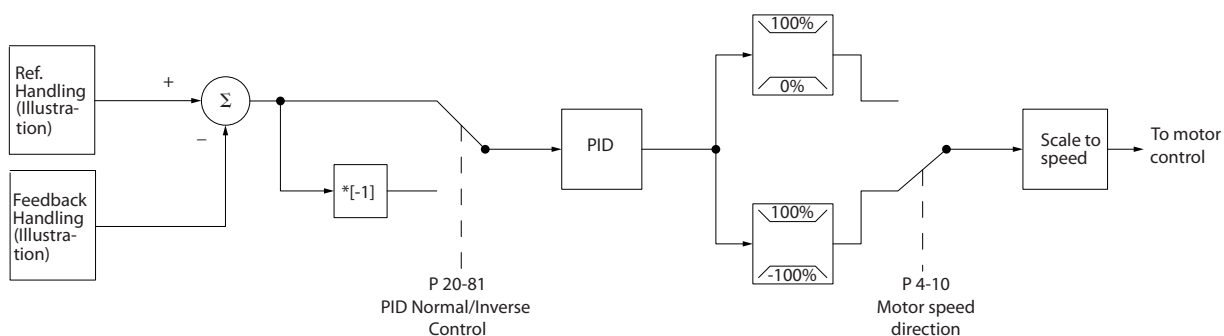

130BA359.12

Illustration 2.26 Block Diagram of Closed Loop Controller

While the default values for the frequency converter’s closed loop controller often provides satisfactory performance, the control of the system can often be optimised by adjusting some of the closed loop controller’s parameters. It is also possible to autotune the PI constants.

### 2.8.7 Feedback Handling

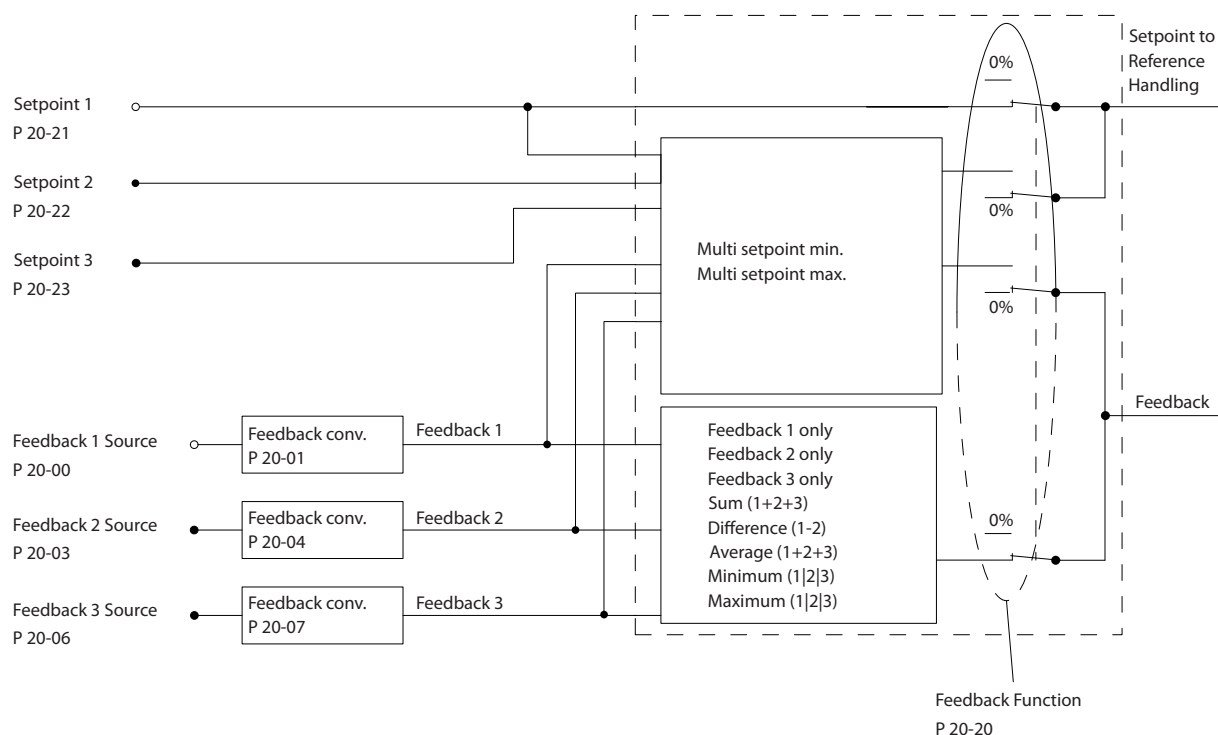

130BA354.12

Illustration 2.27 Block Diagram of Feedback Signal Processing

Feedback handling can be configured to work with applications requiring advanced control, such as multiple setpoints and multiple feedbacks. 3 types of control are common.

#### Single Zone, Single Setpoint

Single Zone, Single Setpoint is a basic configuration. Setpoint 1 is added to any other reference (if any, see Reference Handling) and the feedback signal is selected using 20-20 Feedback Function.

#### Multi Zone, Single Setpoint

Multi Zone Single Setpoint uses 2 or 3 feedback sensors, but only one setpoint. The feedbacks can be added, subtracted (only feedback 1 and 2) or averaged. In addition, the maximum or minimum value may be used. Setpoint 1 is used exclusively in this configuration.

If [13] Multi Setpoint Min is selected, the setpoint/feedback pair with the largest difference controls the speed of the frequency converter. [14] Multi Setpoint Maximum attempts to keep all zones at or below their respective setpoints,

while [13] *Multi Setpoint Min* attempts to keep all zones at or above their respective setpoints.

**Example**

A 2-zone 2 setpoint application Zone 1 setpoint is 15 bar and the feedback is 5.5 bar. Zone 2 setpoint is 4.4 bar and the feedback is 4.6 bar. If [14] *Multi Setpoint Max* is selected, Zone 1's setpoint and feedback are sent to the PID controller, since this has the smaller difference (feedback is higher than setpoint, resulting in a negative difference). If [13] *Multi Setpoint Min* is selected, Zone 2's setpoint and feedback is sent to the PID controller, since this has the larger difference (feedback is lower than setpoint, resulting in a positive difference).

**2.8.8 Feedback Conversion**

In some applications, it may be useful to convert the feedback signal. One example of this is using a pressure signal to provide flow feedback. Since the square root of pressure is proportional to flow, the square root of the pressure signal yields a value proportional to the flow. This is shown in *Illustration 2.28*.

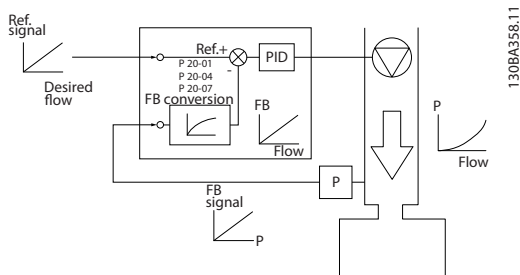

130BA358.11

**Illustration 2.28 Feedback Conversion**

## 2.8.9 Reference Handling

### Details for Open Loop and Closed Loop operation

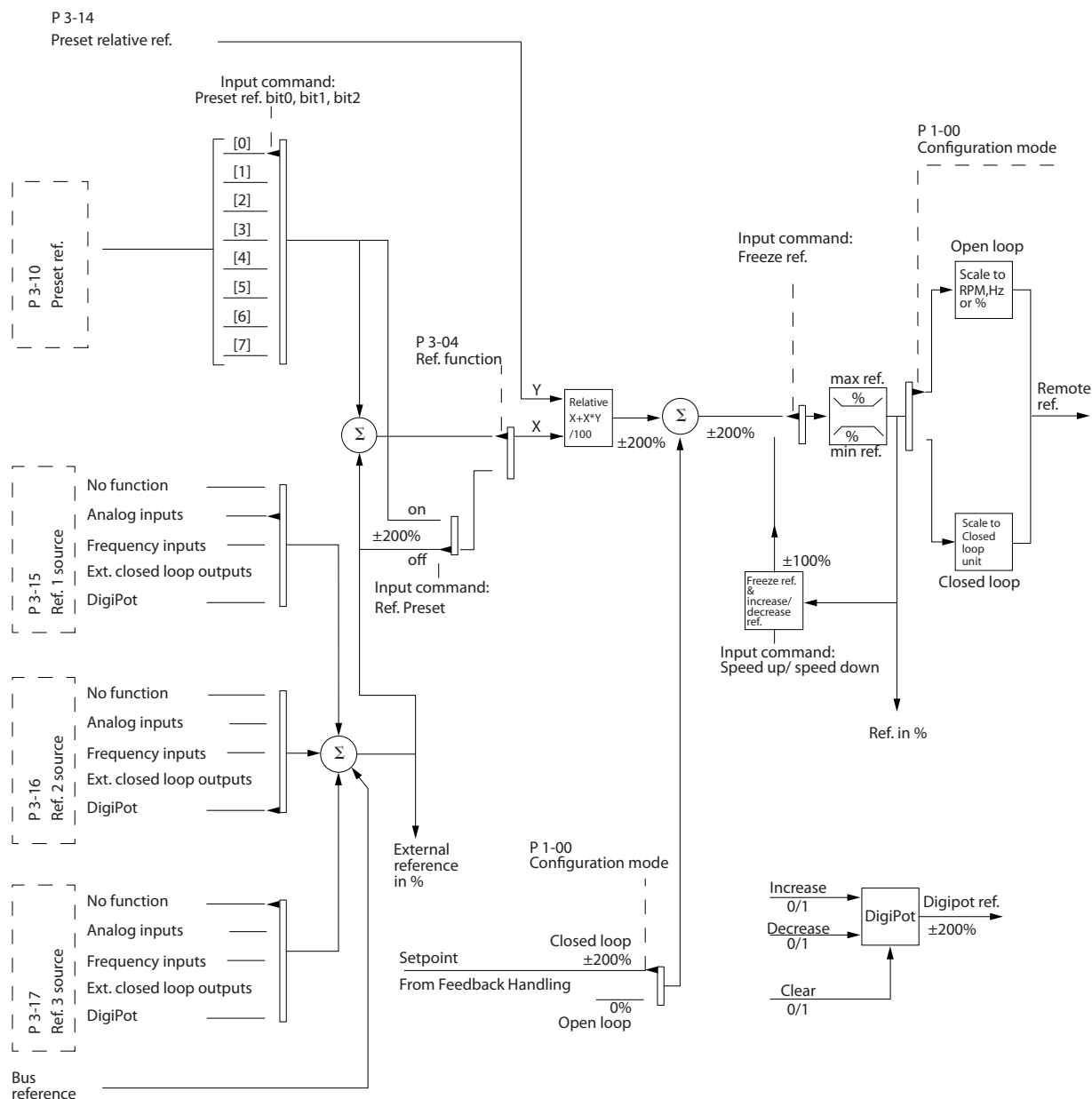

130BA357.12

Illustration 2.29 Block Diagram Showing Remote Reference

The remote reference is comprised of:

- Preset references.
- External references (analog inputs, pulse frequency inputs, digital potentiometer inputs and serial communication bus references).
- The Preset relative reference.
- Feedback controlled setpoint.

Up to 8 preset references can be programmed in the frequency converter. The active preset reference can be

selected using digital inputs or the serial communications bus. The reference can also be supplied externally, most commonly from an analog input. This external source is selected by one of the 3 Reference Source parameters (3-15 Reference 1 Source, 3-16 Reference 2 Source and 3-17 Reference 3 Source). DigiPot is a digital potentiometer. This is also commonly called a Speed Up/Speed Down Control or a Floating Point Control. To set it up, one digital input is programmed to increase the reference, while another digital input is programmed to decrease the reference. A third digital input can be used to reset the DigiPot reference. All reference resources and the bus



reference are added to produce the total external reference. The external reference, the preset reference or the sum of the 2 can be selected to be the active reference. Finally, this reference can be scaled using 3-14 Preset Relative Reference.

The scaled reference is calculated as follows:

$$Reference = X + X \times \left(\frac{Y}{100}\right)$$

Where X is the external reference, the preset reference or the sum of these and Y is 3-14 Preset Relative Reference in [%].

If Y, 3-14 Preset Relative Reference is set to 0%, the reference is affected by the scaling.

### 2.8.10 Example of Closed Loop PID Control

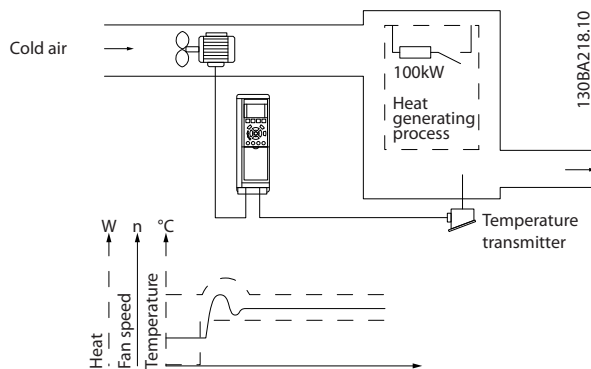

Illustration 2.30 Closed Loop Control for a Ventilation System

In a ventilation system, the temperature is to be maintained at a constant value. The desired temperature is set between -5 and +35 °C using a 0-10 V potentiometer. Because this is a cooling application, if the temperature is above the set-point value, the speed of the fan must be increased to provide more cooling air flow. The temperature sensor has a range of -10 to +40 °C and uses a 2-wire transmitter to provide a 4-20 mA signal. The output frequency range of the frequency converter is 10 to 50 Hz.

1. Start/Stop via switch connected between terminals 12 (+24 V) and 18.
2. Temperature reference via a potentiometer (-5 to +35 °C, 0 to 10 V) connected to terminals 50 (+10 V), 53 (input) and 55 (common).
3. Temperature feedback via transmitter (-10 to 40 °C, 4-20 mA) connected to terminal 54. Switch S202 behind the LCP set to ON (current input).

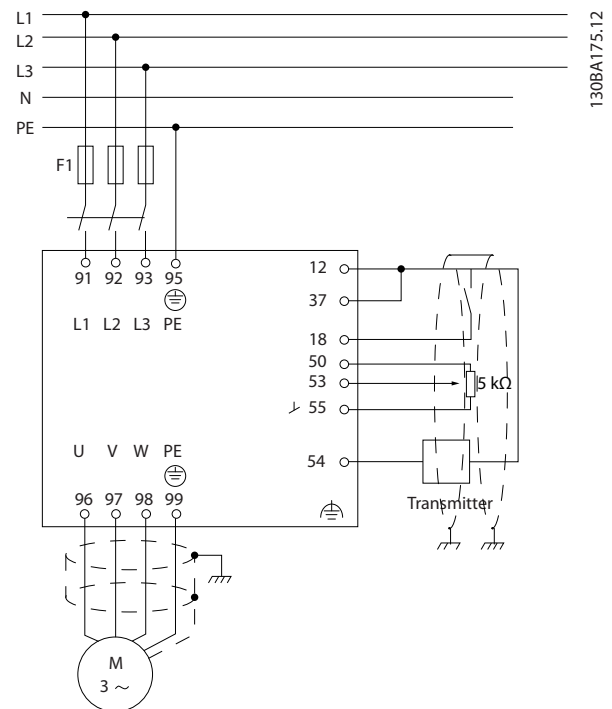

Illustration 2.31 Example of Closed Loop PID Control

### 2.8.11 Programming Order

#### NOTICE

In this example, it is assumed that an induction motor is used, i.e. that 1-10 Motor Construction = [0] Asynchron.

Function	Parameter	Setting
1) Make sure the motor runs properly. Do the following:		
Set the motor parameters using nameplate data.	1-2*	As specified by motor name plate
Run Automatic Motor Adaptation.	1-29	[1] Enable complete AMA and then run the AMA function.
2) Check that the motor is running in the right direction.		
Run Motor Rotation Check.	1-28	If the motor runs in the wrong direction, remove power temporarily and reverse 2 of the motor phases.
3) Make sure the frequency converter limits are set to safe values		
Check that the ramp settings are within capabilities of the frequency converter and allowed application operating specifications.	3-41	60 s
	3-42	60 s Depends on motor/load size! Also active in Hand mode.
Prohibit the motor from reversing (if necessary)	4-10	[0] Clockwise

Function	Parameter	Setting
Set acceptable limits for the motor speed.	4-12	10 Hz, <i>Motor min speed</i>
	4-14	50 Hz, <i>Motor max speed</i>
	4-19	50 Hz, <i>Drive max output frequency</i>
Switch from open loop to closed loop.	1-00	[3] <i>Closed Loop</i>
4) Configure the feedback to the PID controller.		
Select the appropriate reference/feedback unit.	20-12	[71] <i>Bar</i>
5) Configure the set-point reference for the PID controller.		
Set acceptable limits for the set-point reference.	20-13	0 Bar
	20-14	10 Bar
Select current or voltage by switches S201 / S202		
6) Scale the analog inputs used for set-point reference and feedback.		
Scale Analog Input 53 for the pressure range of the potentiometer (0 - 10 Bar, 0 - 10 V).	6-10	0 V
	6-11	10 V (default)
	6-14	0 Bar
	6-15	10 Bar
Scale Analog Input 54 for pressure sensor (0 - 10 Bar, 4 - 20 mA)	6-22	4 mA
	6-23	20 mA (default)
	6-24	0 Bar
	6-25	10 Bar
7) Tune the PID controller parameters.		
Adjust the frequency converter's Closed Loop Controller, if needed.	20-93	See Optimisation of the PID Controller, below.
	20-94	
8) Save to finish.		
Save the parameter setting to the LCP for safe keeping	0-50	[1] <i>All to LCP</i>

Table 2.15 Programming Order

## 2.8.12 Tuning the Frequency Converter Closed Loop Controller

Once the frequency converter's closed loop controller has been set up, the performance of the controller should be tested. In many cases, its performance may be acceptable using the default values of *20-93 PID Proportional Gain* and *20-94 PID Integral Time*. However, in some cases it may be helpful to optimise these parameter values to provide faster system response while still controlling speed overshoot.

## 2.8.13 Manual PID Adjustment

- Start the motor.
- Set *20-93 PID Proportional Gain* to 0.3 and increase it until the feedback signal begins to oscillate. If necessary, start and stop the frequency converter or make step changes in the set-point reference to attempt to cause oscillation. Next reduce the PID proportional gain until the feedback signal stabilizes. Then reduce the proportional gain by 40-60%.
- Set *20-94 PID Integral Time* to 20 s and reduce it until the feedback signal begins to oscillate. If necessary, start and stop the frequency converter or make step changes in the set-point reference to attempt to cause oscillation. Next, increase the PID integral time until the feedback signal stabilizes. Then increase of the integral time by 15-50%.
- 20-95 PID Differentiation Time* should only be used for very fast-acting systems. The typical value is 25% of *20-94 PID Integral Time*. The differential function should only be used when the setting of the proportional gain and the integral time has been fully optimised. Make sure that oscillations of the feedback signal are sufficiently dampened by the low-pass filter for the feedback signal (parameters 6-16, 6-26, 5-54 or 5-59 as required).

## 2.9 General Aspects of EMC

Electrical interference is usually conducted at frequencies in the range 150 kHz to 30 MHz. Airborne interference from the frequency converter system in the range 30 MHz to 1 GHz is generated from the inverter, motor cable, and the motor. As shown in *Illustration 2.32*, capacitance in the motor cable coupled with a high dU/dt from the motor voltage generate leakage currents.

The use of a screened motor cable increases the leakage current (see *Illustration 2.32*) because screened cables have higher capacitance to earth than unscreened cables. If the leakage current is not filtered, it causes greater interference on the mains in the radio frequency range below approximately 5 MHz. Since the leakage current ( $I_1$ ) is carried back to the unit through the screen ( $I_3$ ), there is in principle only a small electro-magnetic field ( $I_4$ ) from the screened motor cable according to *Illustration 2.32*.

The screen reduces the radiated interference, but increases the low-frequency interference on the mains. Connect the motor cable screen to the frequency converter enclosure as well as on the motor enclosure. This is best done by using integrated screen clamps so as to avoid twisted screen ends (pigtailed). Pigtailed increase the screen impedance at higher frequencies, which reduces the screen effect and increases the leakage current ( $I_4$ ).

If a screened cable is used for relay, control cable, signal interface and brake, mount the screen on the enclosure at both ends. In some situations, however, it is necessary to break the screen to avoid current loops.

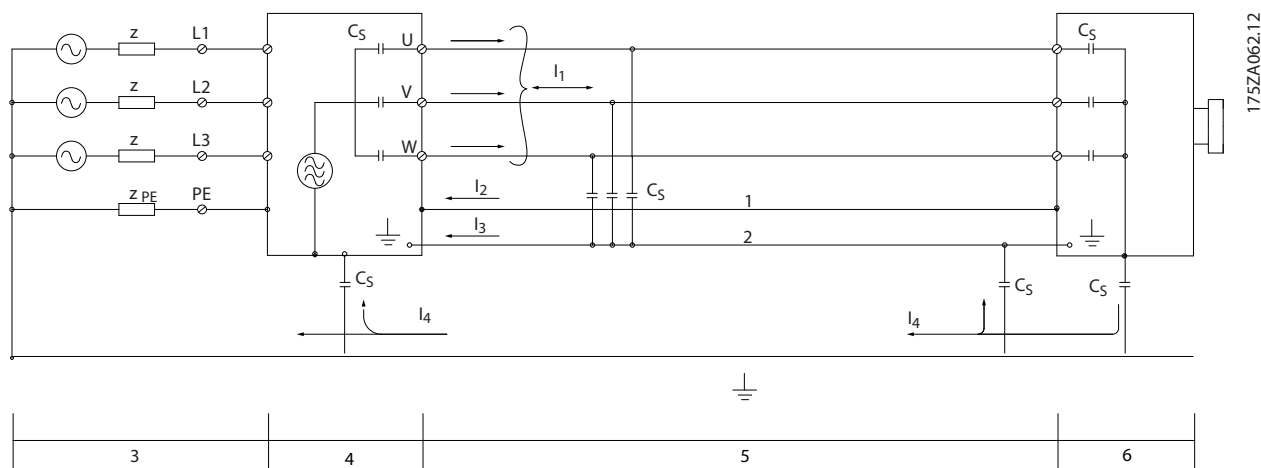

Illustration 2.32 Situation that Generates Leakage Currents

1	Earth wire	4	Frequency converter
2	Screen	5	Screened motor cable
3	AC mains supply	6	Motor

Table 2.16 Legend to *Illustration 2.32*

If the screen is to be placed on a mounting plate for the frequency converter, the mounting plate must be made of metal, to convey the screen currents back to the unit. Moreover, ensure good electrical contact from the mounting plate through the mounting screws to the frequency converter chassis.

When unscreened cables are used, some emission requirements are not complied with, although most immunity requirements are observed.

To reduce the interference level from the entire system (unit+installation), make motor and brake cables as short as possible. Avoid placing cables with a sensitive signal level alongside motor and brake cables. Radio interference higher than 50 MHz (airborne) is especially generated by the control electronics. See for more information on EMC.

## 2.9.1 Emission Requirements

According to the EMC product standard for adjustable speed frequency converters EN/IEC 61800-3:2004 the EMC requirements depend on the intended use of the frequency converter. Four categories are defined in the EMC product standard. The definitions of the 4 categories together with the requirements for mains supply voltage conducted emissions are given in *Table 2.17*.

Category	Definition	Conducted emission requirement according to the limits given in EN 55011
C1	Frequency converters installed in the first environment (home and office) with a supply voltage less than 1000 V.	Class B
C2	Frequency converters installed in the first environment (home and office) with a supply voltage less than 1000 V, which are neither plug-in nor movable and are intended to be installed and commissioned by a professional.	Class A Group 1
C3	Frequency converters installed in the second environment (industrial) with a supply voltage lower than 1000 V.	Class A Group 2
C4	Frequency converters installed in the second environment with a supply voltage equal to or above 1000 V or rated current equal to or above 400 A or intended for use in complex systems.	No limit line. An EMC plan should be made.

**Table 2.17 Emission Requirements**

When the generic (conducted) emission standards are used the frequency converters are required to comply with the following limits

Environment	Generic standard	Conducted emission requirement according to the limits given in EN 55011
First environment (home and office)	EN/IEC 61000-6-3 Emission standard for residential, commercial and light industrial environments.	Class B
Second environment (industrial environment)	EN/IEC 61000-6-4 Emission standard for industrial environments.	Class A Group 1

**Table 2.18 Limits at Generic Emission Standards**

## 2.9.2 EMC Test Results

The following test results have been obtained using a system with a frequency converter, a screened control cable, a control box with potentiometer, as well as a motor and screened motor cable at nominal switching frequency. In Table 2.19 the maximum motor cable lengths for compliance are stated.

RFI filter type		Conducted emission			Radiated emission		
		Cable length [m]			Cable length [m]		
Standards and requirements	EN 55011	Class B Housing, trades and light industries	Class A Group 1 Industrial environ- ment	Class A Group 2 Industrial environ- ment	Class B Housing, trades and light industries	Class A Group 1 Industrial environment	Class A Group 2 Industrial environment
	EN/IEC 61800-3	Category C1 First environ- ment Home and office	Category C2 First environ- ment Home and office	Category C3 Second environ- ment Industrial	Category C1 First environment Home and office	Category C2 First environment Home and office	Category C3 Second environment Industrial
<b>H1</b>							
FC 102	1.1-45 kW 200-240 V	50	150	150	No	Yes	Yes
	1.1-90 kW 380-480 V	50	150	150	No	Yes	Yes
<b>H2</b>							
FC 102	1.1-3.7 kW 200-240 V	No	No	5	No	No	No
	5.5-45 kW 200-240 V	No	No	25	No	No	No
	1.1-7.5 kW 380-500 V	No	No	5	No	No	No
	11-90 kW 380-500 V <sup>4)</sup>	No	No	25	No	No	No
	11-22 kW 525-690 V <sup>1, 4)</sup>	No	No	25	No	No	No
	30-90 kW 525-690 V <sup>2, 4)</sup>	No	No	25	No	No	No
<b>H3</b>							
FC 102	1.1-45 kW 200-240V	10	50	75	No	Yes	Yes
	1.1-90 kW 380-480V	10	50	75	No	Yes	Yes
<b>H4</b>							
FC 102	11-30 kW 525-690 V <sup>1)</sup>	No	100	100	No	Yes	Yes
	37-90 kW 525-690 V <sup>2)</sup>	No	150	150	No	Yes	Yes
<b>Hx<sup>3)</sup></b>							
FC 102	1.1-90 kW 525-600 V	No	No	No	No	No	No

**Table 2.19 EMC Test Results (Emission)**

1) Enclosure Type B

2) Enclosure Type C

3) Hx versions can be used according to EN/IEC 61800-3 category C4

4) T7, 37-90 kW complies with class A group 1 with 25 m motor cable. Some restrictions for the installation apply (contact Danfoss for details).

HX, H1, H2, H3, H4 or H5 is defined in the type code pos. 16-17 for EMC filters

HX - No EMC filters built in the frequency converter (600 V units only)

H1 - Integrated EMC filter. Fulfil EN 55011 Class A1/B and EN/IEC 61800-3 Category 1/2

H2 - No additional EMC filter. Fulfil EN 55011 Class A2 and EN/IEC 61800-3 Category 3

H3 - Integrated EMC filter. Fulfil EN 55011 class A1/B and EN/IEC 61800-3 Category 1/2

H4 - Integrated EMC filter. Fulfil EN 55011 class A1 and EN/IEC 61800-3 Category 2

H5 - Marine versions. Fulfill same emissions levels as H2 versions

2

### 2.9.3 General Aspects of Harmonics Emission

A frequency converter takes up a non-sinusoidal current from mains, which increases the input current  $I_{RMS}$ . A non-sinusoidal current is transformed with a Fourier analysis and split into sine-wave currents with different frequencies, that is, different harmonic currents  $I_n$  with 50 Hz basic frequency:

	$I_1$	$I_5$	$I_7$
Hz	50	250	350

Table 2.20 Harmonic Currents

The harmonics do not affect the power consumption directly, but increase the heat losses in the installation (transformer, cables). So, in plants with a high percentage of rectifier load, maintain harmonic currents at a low level to avoid overload of the transformer and high temperature in the cables.

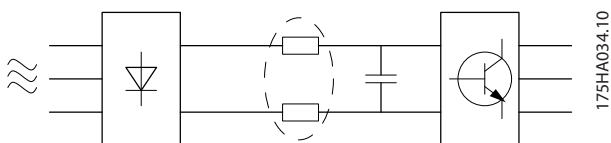

Illustration 2.33 Harmonic Currents

**NOTICE**

Some of the harmonic currents might disturb communication equipment connected to the same transformer or cause resonance with power-factor correction batteries.

To ensure low harmonic currents, the frequency converter is equipped with intermediate circuit coils as standard. This normally reduces the input current  $I_{RMS}$  by 40%.

The voltage distortion on the mains supply voltage depends on the size of the harmonic currents multiplied by the mains impedance for the frequency in question. The total voltage distortion THD is calculated based on the individual voltage harmonics using this formula:

$$THD\% = \sqrt{u_5^2 + u_7^2 + \dots + u_N^2}$$

( $U_N\%$  of  $U$ )

### 2.9.4 Harmonics Emission Requirements

#### Equipment connected to the public supply network

Options	Definition
1	IEC/EN 61000-3-2 Class A for 3-phase balanced equipment (for professional equipment only up to 1 kW total power).
2	IEC/EN 61000-3-12 Equipment 16 A-75 A and professional equipment as from 1 kW up to 16 A phase current.

Table 2.21 Connected Equipment

### 2.9.5 Harmonics Test Results (Emission)

Power sizes up to PK75 in T2 and T4 comply with IEC/EN 61000-3-2 Class A. Power sizes from P1K1 and up to P18K in T2 and up to P90K in T4 comply with IEC/EN 61000-3-12, Table 4. Power sizes P110 - P450 in T4 also comply with IEC/EN 61000-3-12 even though not required because currents are above 75 A.

	Individual harmonic current $I_n/I_1$ (%)			
	$I_5$	$I_7$	$I_{11}$	$I_{13}$
Actual (typical)	40	20	10	8
Limit for $R_{sce} \geq 120$	40	25	15	10
	Harmonic current distortion factor (%)			
	THD		PWHD	
Actual (typical)	46		45	
Limit for $R_{sce} \geq 120$	48		46	

Table 2.22 Harmonics Test Results (Emission)

If the short-circuit power of the supply  $S_{sc}$  is greater than or equal to:

$$SSC = \sqrt{3} \times R_{SCE} \times U_{mains} \times I_{equ} = \sqrt{3} \times 120 \times 400 \times I_{equ}$$

at the interface point between the user's supply and the public system ( $R_{sce}$ ).

It is the responsibility of the installer or user of the equipment to ensure that the equipment is connected only to a supply with a short-circuit power  $S_{sc}$  greater than or equal to what is specified above. If necessary, consult the distribution network operator.

Other power sizes can be connected to the public supply network by consultation with the distribution network operator.

Compliance with various system level guidelines: The harmonic current data in Table 2.22 are given in accordance with IEC/EN61000-3-12 with reference to the

Power Drive Systems product standard. The data may be used to calculate the harmonic currents' influence on the power supply system and to document compliance with relevant regional guidelines: IEEE 519 -1992; G5/4.

### 2.9.6 Immunity Requirements

The immunity requirements for frequency converters depend on the environment where they are installed. The requirements for the industrial environment are higher than the requirements for the home and office environment. All Danfoss frequency converters comply with the requirements for the industrial environment and consequently comply also with the lower requirements for home and office environment with a large safety margin.

To document immunity against electrical interference from electrical phenomena, the following immunity tests have been made in accordance with following basic standards:

- **EN 61000-4-2 (IEC 61000-4-2):** Electrostatic discharges (ESD): Simulation of electrostatic discharges from human beings.
- **EN 61000-4-3 (IEC 61000-4-3):** Incoming electromagnetic field radiation, amplitude modulated

simulation of the effects of radar and radio communication equipment as well as mobile communications equipment.

- **EN 61000-4-4 (IEC 61000-4-4):** Burst transients: Simulation of interference brought about by switching a contactor, relay or similar devices.
- **EN 61000-4-5 (IEC 61000-4-5):** Surge transients: Simulation of transients brought about e.g. by lightning that strikes near installations.
- **EN 61000-4-6 (IEC 61000-4-6):** RF Common mode: Simulation of the effect from radio-transmission equipment joined by connection cables.

See Table 2.23.

Basic standard	Burst IEC 61000-4-4	Surge IEC 61000-4-5	ESD IEC 61000-4-2	Radiated electromagnetic field IEC 61000-4-3	RF common mode voltage IEC 61000-4-6
Acceptance criterion	B	B	B	A	A
Voltage range: 200-240 V, 380-500 V, 525-600 V, 525-690 V					
Line	4 kV CM	2 kV/2 Ω DM 4 kV/12 Ω CM	—	—	10 V <sub>RMS</sub>
Motor	4 kV CM	4 kV/2 Ω <sup>1)</sup>	—	—	10 V <sub>RMS</sub>
Brake	4 kV CM	4 kV/2 Ω <sup>1)</sup>	—	—	10 V <sub>RMS</sub>
Load sharing	4 kV CM	4 kV/2 Ω <sup>1)</sup>	—	—	10 V <sub>RMS</sub>
Control wires	2 kV CM	2 kV/2 Ω <sup>1)</sup>	—	—	10 V <sub>RMS</sub>
Standard bus	2 kV CM	2 kV/2 Ω <sup>1)</sup>	—	—	10 V <sub>RMS</sub>
Relay wires	2 kV CM	2 kV/2 Ω <sup>1)</sup>	—	—	10 V <sub>RMS</sub>
Application and Fieldbus options	2 kV CM	2 kV/2 Ω <sup>1)</sup>	—	—	10 V <sub>RMS</sub>
LCP cable	2 kV CM	2 kV/2 Ω <sup>1)</sup>	—	—	10 V <sub>RMS</sub>
External 24 V DC	2 V CM	0.5 kV/2 Ω DM 1 kV/12 Ω CM	—	—	10 V <sub>RMS</sub>
Enclosure	—	—	8 kV AD 6 kV CD	10V/m	—

Table 2.23 EMC Immunity Form

1) Injection on cable shield  
 AD: Air Discharge  
 CD: Contact Discharge  
 CM: Common mode  
 DM: Differential mode

## 2.10 Galvanic Isolation (PELV)

### 2.10.1 PELV - Protective Extra Low Voltage

PELV offers protection by way of extra low voltage. Protection against electric shock is ensured when the electrical supply is of the PELV type and the installation is made as described in local/national regulations on PELV supplies.

All control terminals and relay terminals 01-03/04-06 comply with PELV (Protective Extra Low Voltage), with the exception of grounded Delta leg above 400 V.

Galvanic (ensured) isolation is obtained by fulfilling requirements for higher isolation and by providing the relevant creepage/clearance distances. These requirements are described in the EN 61800-5-1 standard.

The components that make up the electrical isolation, as described below, also comply with the requirements for higher isolation and the relevant test as described in EN 61800-5-1.

The PELV galvanic isolation can be shown in 6 locations (see *Illustration 2.34*):

To maintain PELV, all connections made to the control terminals must be PELV, e.g. thermistor must be reinforced/double insulated.

1. Power supply (SMPS) incl. signal isolation of  $U_{DC}$ , indicating the voltage of intermediate DC-link circuit.
2. Gate drive that runs the IGBTs (trigger transformers/opto-couplers).
3. Current transducers.
4. Opto-coupler, brake module.
5. Internal inrush, RFI, and temperature measurement circuits.
6. Custom relays.
7. Mechanical brake.

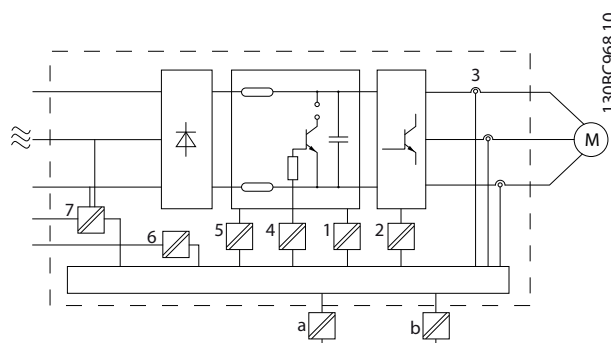

Illustration 2.34 Galvanic Isolation

The functional galvanic isolation (a and b on drawing) is for the 24 V back-up option and for the RS-485 standard bus interface.

### **WARNING**

Installation at high altitude:

**380-500 V, enclosure types A, B and C:** At altitudes above 2 km, contact Danfoss regarding PELV.

**525-690 V:** At altitudes above 2 km, contact Danfoss regarding PELV.

### **WARNING**

Touching the electrical parts could be fatal - even after the equipment has been disconnected from mains. Also make sure that other voltage inputs have been disconnected, such as load sharing (linkage of DC intermediate circuit), as well as the motor connection for kinetic back-up.

Before touching any electrical parts, wait at least the amount of time indicated in *Table 2.19*.

Shorter time is allowed only if indicated on the nameplate for the specific unit.

## 2.11 Earth Leakage Current

Follow national and local codes regarding protective earthing of equipment with a leakage current > 3,5 mA. Frequency converter technology implies high frequency switching at high power. This generates a leakage current in the earth connection. A fault current in the frequency converter at the output power terminals might contain a DC component which can charge the filter capacitors and cause a transient earth current.

The earth leakage current is made up of several contributions and depends on various system configurations including RFI filtering, screened motor cables, and frequency converter power.



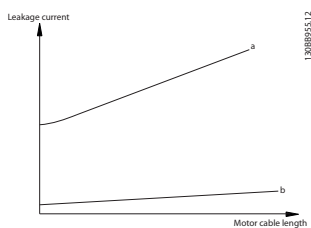

Illustration 2.35 Cable Length and Power Size Influence on Leakage Current. Pa > Pb

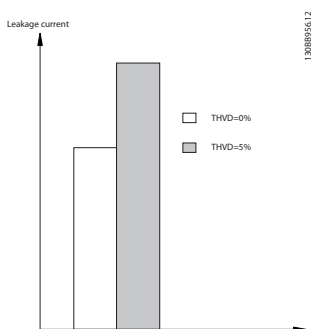

Illustration 2.36 Line Distortion Influences Leakage Current

**NOTICE**

When a filter is used, turn off 14-50 RFI Filter when charging the filter to avoid that a high leakage current makes the RCD switch.

EN/IEC61800-5-1 (Power Drive System Product Standard) requires special care if the leakage current exceeds 3.5 mA. Grounding must be reinforced in one of the following ways:

- Ground wire (terminal 95) of at least 10 mm<sup>2</sup>
- 2 separate ground wires both complying with the dimensioning rules

See EN/IEC61800-5-1 and EN50178 for further information.

**Using RCDs**

Where residual current devices (RCDs), also known as earth leakage circuit breakers (ELCBs), are used, comply with the following:

- Use RCDs of type B only which are capable of detecting AC and DC currents
- Use RCDs with an inrush delay to prevent faults due to transient earth currents
- Dimension RCDs according to the system configuration and environmental considerations

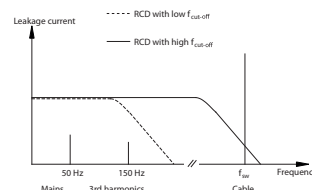

Illustration 2.37 Main Contributions to Leakage Current

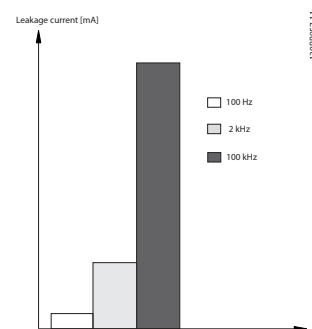

Illustration 2.38 The Influence of the Cut-off Frequency of the RCD on what is Responded to/measured

See also RCD Application Note, MN90G.

2.12 Brake Function

2.12.1 Selection of Brake Resistor

In certain applications, for instance in tunnel or underground railway station ventilation systems, it is desirable to bring the motor to a stop more rapidly than can be achieved through controlling via ramp down or by free-wheeling. In such applications, dynamic braking with a brake resistor may be utilised. Using a brake resistor ensures that the energy is absorbed in the resistor and not in the frequency converter.

If the amount of kinetic energy transferred to the resistor in each braking period is not known, the average power can be calculated on the basis of the cycle time and braking time also called intermittent duty cycle. The resistor intermittent duty cycle is an indication of the duty cycle at which the resistor is active. *Illustration 2.39* shows a typical braking cycle.

The intermittent duty cycle for the resistor is calculated as follows:

$$\text{Duty Cycle} = t_b / T$$

T = cycle time in seconds

t<sub>b</sub> is the braking time in seconds (as part of the total cycle time)

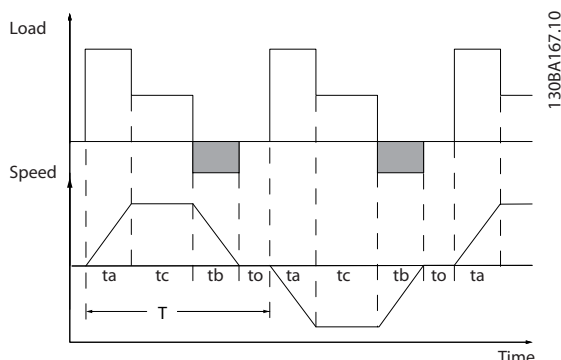

Illustration 2.39 Intermittent Duty Cycle for the Resistor

Danfoss offers brake resistors with duty cycle of 5%, 10% and 40% suitable for use with the VLT® HVAC Drive frequency converter series. If a 10% duty cycle resistor is applied, this is able of absorbing braking power upto 10% of the cycle time with the remaining 90% being used to dissipate heat from the resistor.

For further selection advice, contact Danfoss.

### 2.12.2 Brake Resistor Calculation

The brake resistance is calculated as shown:

$R_{br} [\Omega] = \frac{U_{dc}^2}{P_{peak}}$
where
$P_{peak} = P_{motor} \times M_{br} \times \eta_{motor} \times \eta [W]$

Table 2.24 Brake Resistor Calculation

As can be seen, the brake resistance depends on the intermediate circuit voltage ( $U_{DC}$ ). The brake function of the frequency converter is settled in 3 areas of mains power supply:

Size [V]	Brake active [V]	Warning before cut out [V]	Cut out (trip) [V]
3x200-240	390 ( $U_{DC}$ )	405	410
3x380-480	778	810	820
3x525-600	943	965	975
3x525-690	1084	1109	1130

Table 2.25 Brake Function Settled in 3 Areas of Mains Supply

#### **NOTICE**

Check that the brake resistor can cope with a voltage of 410 V, 820 V or 975 V - unless Danfoss brake resistors are used.

Danfoss recommends the brake resistance  $R_{rec}$ , i.e. one that guarantees that the is able to brake at the highest braking torque ( $M_{br(\%)}$ ) of 110%. The formula can be written as:

$$R_{rec}[\Omega] = \frac{U_{dc}^2 \times 100}{P_{motor} \times M_{br(\%)} \times \eta_{motor}}$$

$\eta_{motor}$  is typically at 0.90

$\eta$  is typically at 0.98

For 200 V, 480 V and 600 V frequency converters,  $R_{rec}$  at 160% braking torque is written as:

$$200V : R_{rec} = \frac{107780}{P_{motor}} [\Omega]$$

$$480V : R_{rec} = \frac{375300}{P_{motor}} [\Omega]^{1)}$$

$$480V : R_{rec} = \frac{428914}{P_{motor}} [\Omega]^{2)}$$

$$600V : R_{rec} = \frac{630137}{P_{motor}} [\Omega]$$

$$690V : R_{rec} = \frac{832664}{P_{motor}} [\Omega]$$

1) For frequency converters  $\leq 7.5$  kW shaft output

2) For frequency converters  $> 7.5$  kW shaft output

#### **NOTICE**

The brake resistor circuit resistance selected should not be higher than that recommended by Danfoss. If a brake resistor with a higher ohmic value is selected, the braking torque may not be achieved because there is a risk that the frequency converter cuts out for safety reasons.

#### **NOTICE**

If a short circuit in the brake transistor occurs, power dissipation in the brake resistor is only prevented by using a mains switch or contactor to disconnect the mains for the frequency converter. (The contactor can be controlled by the frequency converter).

#### **WARNING**

Do not touch the brake resistor as it can get very hot while/after braking.

### 2.12.3 Control with Brake Function

The brake is protected against short-circuiting of the brake resistor, and the brake transistor is monitored to ensure that short-circuiting of the transistor is detected. A relay/digital output can be used for protecting the brake resistor against overloading in connection with a fault in the frequency converter.

In addition, the brake enables reading out the momentary power and the mean power for the latest 120 s. The brake can also monitor the power energising and ensure that it does not exceed the limit selected in 2-12 Brake Power Limit (kW). In 2-13 Brake Power Monitoring, select the

function to carry out when the power transmitted to the brake resistor exceeds the limit set in *2-12 Brake Power Limit (kW)*.

### NOTICE

**Monitoring the brake power is not a safety function; a thermal switch is required for that purpose. The brake resistor circuit is not earth leakage protected.**

Overvoltage control (OVC) (exclusive brake resistor) can be selected as an alternative brake function in *2-17 Over-voltage Control*. This function is active for all units. The function ensures that a trip can be avoided, if the DC-link voltage increases. This is done by increasing the output frequency to limit the voltage from the DC-link. It is a useful function, e.g. if the ramp-down time is too short since tripping of the frequency converter is avoided. In this situation, the ramp-down time is extended.

### NOTICE

**OVC cannot be activated when running a PM motor (when *1-10 Motor Construction* is set to [1] PM non salient SPM).**

## 2.12.4 Brake Resistor Cabling

### EMC (twisted cables/shielding)

Twist the wires to reduce the electrical noise from the wires between the brake resistor and the frequency converter.

For enhanced EMC performance, use a metal screen.

## 2.13 Extreme Running Conditions

### Short Circuit (Motor Phase – Phase)

The frequency converter is protected against short circuits by current measurement in each of the 3 motor phases or in the DC-link. A short circuit between 2 output phases causes an overcurrent in the inverter. The inverter is turned off individually when the short circuit current exceeds the permitted value (Alarm 16 Trip Lock).

To protect the frequency converter against a short circuit at the load sharing and brake outputs, see the design guidelines.

### Switching on the output

Switching on the output between the motor and the frequency converter is permitted. Fault messages may appear. Enable flying start to catch a spinning motor.

### Motor-generated overvoltage

The voltage in the intermediate circuit is increased when the motor acts as a generator. This occurs in following cases:

- The load drives the motor (at constant output frequency from the frequency converter), ie. the load generates energy.
- During deceleration (ramp-down) if the moment of inertia is high, the friction is low and the ramp-down time is too short for the energy to be dissipated as a loss in the frequency converter, the motor and the installation.
- Incorrect slip compensation setting may cause higher DC-link voltage.
- Back-EMF from PM motor operation. If coasted at high RPM, the PM motor back-EMF may potentially exceed the maximum voltage tolerance of the frequency converter and cause damage. To help prevent this, the value of *4-19 Max Output Frequency* is automatically limited based on an internal calculation based on the value of *1-40 Back EMF at 1000 RPM*, *1-25 Motor Nominal Speed* and *1-39 Motor Poles*. If it is possible that the motor may overspeed (e.g. due to excessive windmilling effects), Danfoss recommends using a brake resistor.

### WARNING

**The frequency converter must be equipped with a brake chopper.**

The control unit may attempt to correct the ramp if possible (*2-17 Over-voltage Control*).

The inverter turns off to protect the transistors and the intermediate circuit capacitors when a certain voltage level is reached.

See *2-10 Brake Function* and *2-17 Over-voltage Control* to select the method used for controlling the intermediate circuit voltage level.

### NOTICE

**OVC cannot be activated when running a PM motor (when *1-10 Motor Construction* is set to [1] PM non salient SPM).**

**Mains drop-out**

During a mains drop-out, the frequency converter keeps running until the intermediate circuit voltage drops below the minimum stop level, which is typically 15% below the frequency converter's lowest rated supply voltage. The mains voltage before the drop-out and the motor load determines how long it takes for the inverter to coast.

**Static overload in VVC<sup>plus</sup> mode**

When the frequency converter is overloaded (the torque limit in 4-16 Torque Limit Motor Mode/4-17 Torque Limit Generator Mode is reached), the controls reduces the output frequency to reduce the load.

If the overload is excessive, a current may occur that makes the frequency converter cut out after approx. 5-10 s.

Operation within the torque limit is limited in time (0-60 s) in 14-25 Trip Delay at Torque Limit.

**2.13.1 Motor Thermal Protection**

This is the way Danfoss is protecting the motor from being overheated. It is an electronic feature that simulates a bimetal relay based on internal measurements. The characteristic is shown in Illustration 2.40

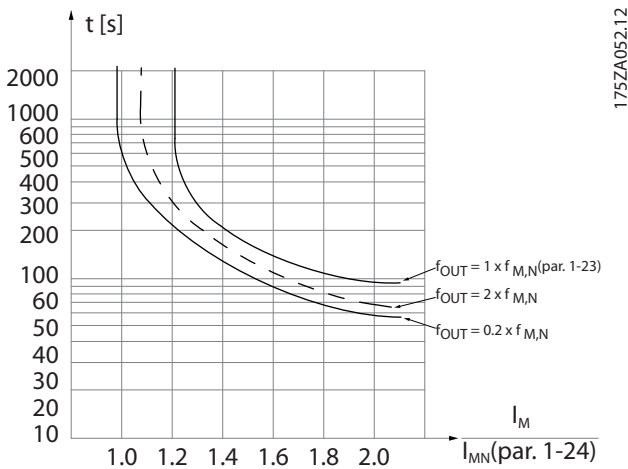

**Illustration 2.40** The X-axis is showing the ratio between  $I_{motor}$  and  $I_{motor}$  nominal. The Y-axis is showing the time in seconds before the ETR cuts off and trips the frequency converter. The curves are showing the characteristic nominal speed at twice the nominal speed and at 0,2x the nominal speed.

It is clear that at lower speed, the ETR cuts of at lower heat due to less cooling of the motor. In that way the motor are protected from being over heated even at low speed. The ETR feature is calculating the motor temperature based on actual current and speed. The calculated temperature is visible as a read out parameter in 16-18 Motor Thermal in the frequency converter.

The thermistor cut-out value is  $> 3\text{ k}\Omega$ .

Integrate a thermistor (PTC sensor) in the motor for winding protection.

Motor protection can be implemented using a range of techniques: PTC sensor in motor windings; mechanical thermal switch (Klixon type); or Electronic Thermal Relay (ETR).

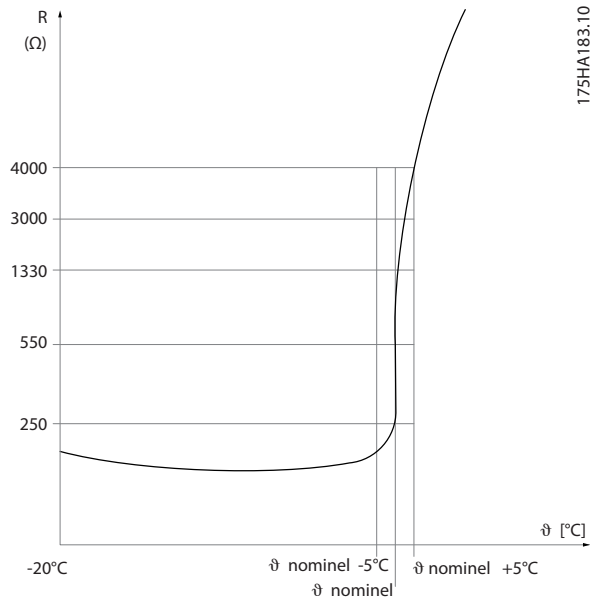

**Illustration 2.41** The Thermistor Cut-out

Using a digital input and 24 V as power supply:  
Example: The frequency converter trips when the motor temperature is too high.

Parameter set-up:  
Set 1-90 Motor Thermal Protection to [2] Thermistor Trip  
Set 1-93 Thermistor Source to [6] Digital Input 33

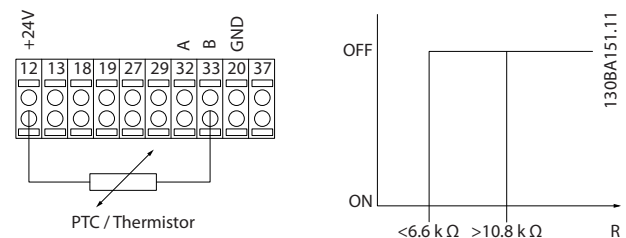

**Illustration 2.42** Using a Digital Input and 24 V as Power Supply

Using a digital input and 10 V as power supply:  
Example: The frequency converter trips when the motor temperature is too high.

Parameter set-up:  
Set 1-90 Motor Thermal Protection to [2] Thermistor Trip

Set 1-93 Thermistor Source to [6] Digital Input 33

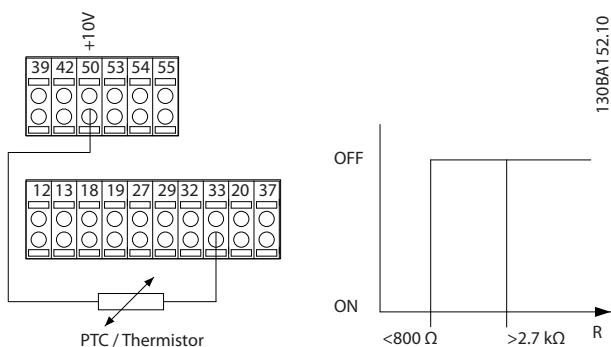

Illustration 2.43 Using a Digital Input and 10 V as Power Supply

Using an analog input and 10 V as power supply:  
 Example: The frequency converter trips when the motor temperature is too high.  
 Parameter set-up:  
 Set 1-90 Motor Thermal Protection to [2] Thermistor Trip  
 Set 1-93 Thermistor Source to [2] Analog Input 54  
 Do not select a reference source.

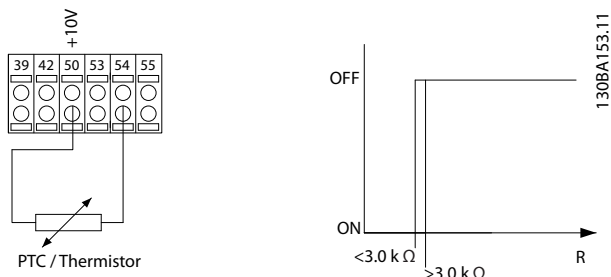

Illustration 2.44 Using an Analog Input and 10 V as Power Supply

Input Digital/analog	Supply Voltage V	Threshold Cut-out Values
Digital	24	< 6.6 k $\Omega$ - > 10.8 k $\Omega$
Digital	10	< 800 $\Omega$ - > 2.7 k $\Omega$
Analog	10	< 3.0 k $\Omega$ - > 3.0 k $\Omega$

Table 2.26 Threshold Cut-out Values

**NOTICE**

Check that the chosen supply voltage follows the specification of the used thermistor element.

**Summary**

With the torque limit feature the motor is protected for being overloaded independent of the speed. With the ETR, the motor is protected for being over heated and there is no need for any further motor protection. That means

when the motor is heated up, the ETR timer controls for how long time the motor can be running at the high temperature, before it is stopped to prevent overheating. If the motor is overloaded without reaching the temperature where the ETR shuts of the motor, the torque limit is protecting the motor and application for being overloaded.

ETR is activated in 1-90 Motor Thermal Protection and is controlled in 4-16 Torque Limit Motor Mode. The time before the torque limit warning trips the frequency converter is set in 14-25 Trip Delay at Torque Limit.

## 3 Selection

### 3

### 3.1 Options and Accessories

Danfoss offers a wide range of options and accessories for the frequency converters.

#### 3.1.1 Mounting of Option Modules in Slot B

Disconnect power to the frequency converter.

For A2 and A3 enclosure types:

1. Remove the LCP, the terminal cover, and the LCP frame from the frequency converter.
2. Fit the MCB1xx option card into slot B.
3. Connect the control cables and relieve the cable by the enclosed cable strips. Remove the knockout in the extended LCP frame delivered in the option set, so that the option fits under the extended LCP frame.
4. Fit the extended LCP frame and terminal cover.
5. Fit the LCP or blind cover in the extended LCP frame.
6. Connect power to the frequency converter.
7. Set up the input/output functions in the corresponding parameters, as mentioned in *chapter 9.2 General Specifications*.

For B1, B2, C1 and C2 enclosure types:

1. Remove the LCP and the LCP cradle.
2. Fit the MCB 1xx option card into slot B.
3. Connect the control cables and relieve the cable by the enclosed cable strips.
4. Fit the cradle.
5. Fit the LCP.

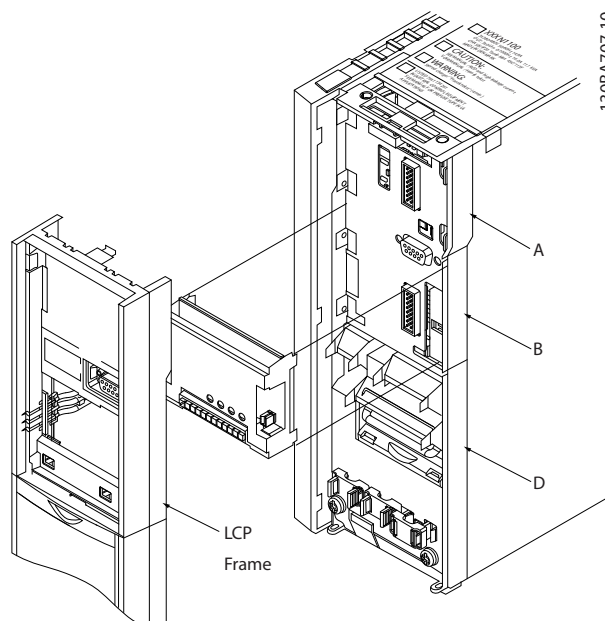

Illustration 3.1 A2, A3 and B3 Enclosure Types

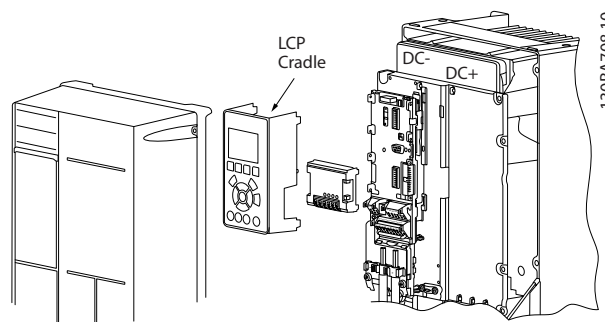

Illustration 3.2 A5, B1, B2, B4, C1, C2, C3 and C4 Enclosure Types

#### 3.1.2 General Purpose I/O Module MCB 101

MCB 101 is used for extension of the number of digital and analog inputs and outputs of the frequency converter.

MCB 101 must be fitted into slot B in the frequency converter. Contents:

- MCB 101 option module
- Extended LCP frame
- Terminal cover

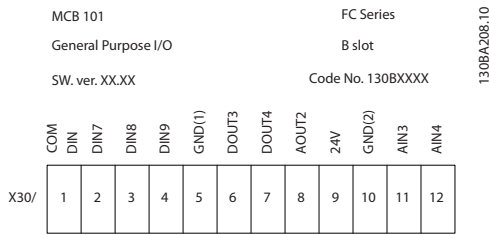

Illustration 3.3

**Galvanic isolation in the MCB 101**

Digital/analog inputs are galvanically isolated from other inputs/outputs on the MCB 101 and in the control card of the frequency converter. Digital/analog outputs in the MCB 101 are galvanically isolated from other inputs/outputs on the MCB 101, but not from these on the control card of the frequency converter.

If the digital inputs 7, 8 or 9 are to be switched by use of the internal 24 V power supply (terminal 9) the connection between terminal 1 and 5 which is shown in *Illustration 3.4* has to be established.

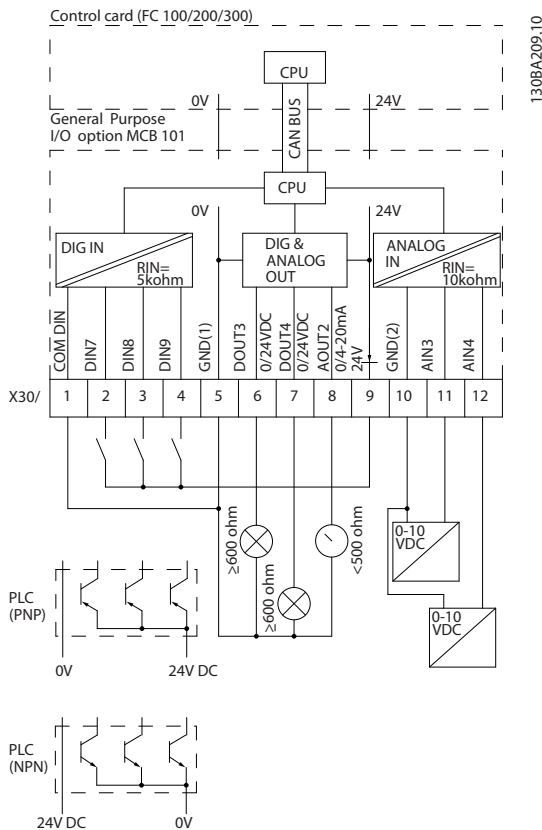

Illustration 3.4 Principle Diagram

**3.1.3 Digital Inputs - Terminal X30/1-4**

Number of digital inputs	Voltage level	Voltage levels	Tolerance	Max. Input impedance
3	0-24 V DC	PNP type: Common = 0 V Logic "0": Input < 5 V DC Logic "0": Input > 10 V DC NPN type: Common = 24 V Logic "0": Input > 19 V DC Logic "0": Input < 14 V DC	± 28 V continuous ± 37 V in minimum 10 s	Approx. 5 kΩ

Table 3.1 Parameters for set-up: 5-16, 5-17 and 5-18

**3.1.4 Analog Voltage Inputs - Terminal X30/10-12**

Number of analog voltage inputs	Standardised input signal	Tolerance	Resolution	Max. Input impedance
2	0-10 V DC	± 20 V continuously	10 bits	Approx. 5 KΩ

Table 3.2 Parameters for set-up: 6-3\*, 6-4\* and 16-76

**3.1.5 Digital Outputs - Terminal X30/5-7**

Number of digital outputs	Output level	Tolerance	Max. impedance
2	0 or 2 V DC	± 4 V	≥ 600 Ω

Table 3.3 Parameters for set-up: 5-32 and 5-33

**3.1.6 Analog Outputs - Terminal X30/5+8**

Number of analog outputs	Output signal level	Tolerance	Max. impedance
1	0/4 - 20 mA	±0.1 mA	< 500 Ω

Table 3.4 Parameters for set-up: 6-6\* and 16-77

### 3.1.7 Relay Option MCB 105

The MCB 105 option includes 3 pieces of SPDT contacts and must be fitted into option slot B.

Electrical Data:

Max terminal load (AC-1) <sup>1)</sup> (Resistive load)	240 V AC 2 A
Max terminal load (AC-15) <sup>1)</sup> (Inductive load @ cosφ 0.4)	240 V AC 0.2 A
Max terminal load (DC-1) <sup>1)</sup> (Resistive load)	24 V DC 1 A
Max terminal load (DC-13) <sup>1)</sup> (Inductive load)	24 V DC 0.1 A
Min terminal load (DC)	5 V 10 mA
Max switching rate at rated load/min load	6 min <sup>-1</sup> /20 s <sup>-1</sup>

<sup>1)</sup> IEC 947 part 4 and 5

When the relay option kit is ordered separately the kit includes:

- Relay Module MCB 105
- Extended LCP frame and enlarged terminal cover
- Label for covering access to switches S201, S202 and S801
- Cable strips for fastening cables to relay module

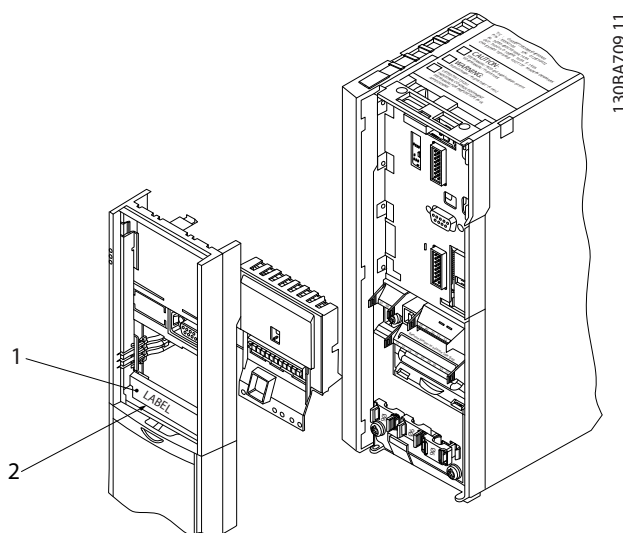

Illustration 3.5 Relay Option MCB 105

A2-A3-A4-B3	A5-B1-B2-B4-C1-C2-C3-C4
<sup>1)</sup> <b>IMPORTANT!</b> The label <b>MUST</b> be placed on the LCP frame as shown (UL approved).	

Table 3.5 Legend to *Illustration 3.5* and *Illustration 3.6*



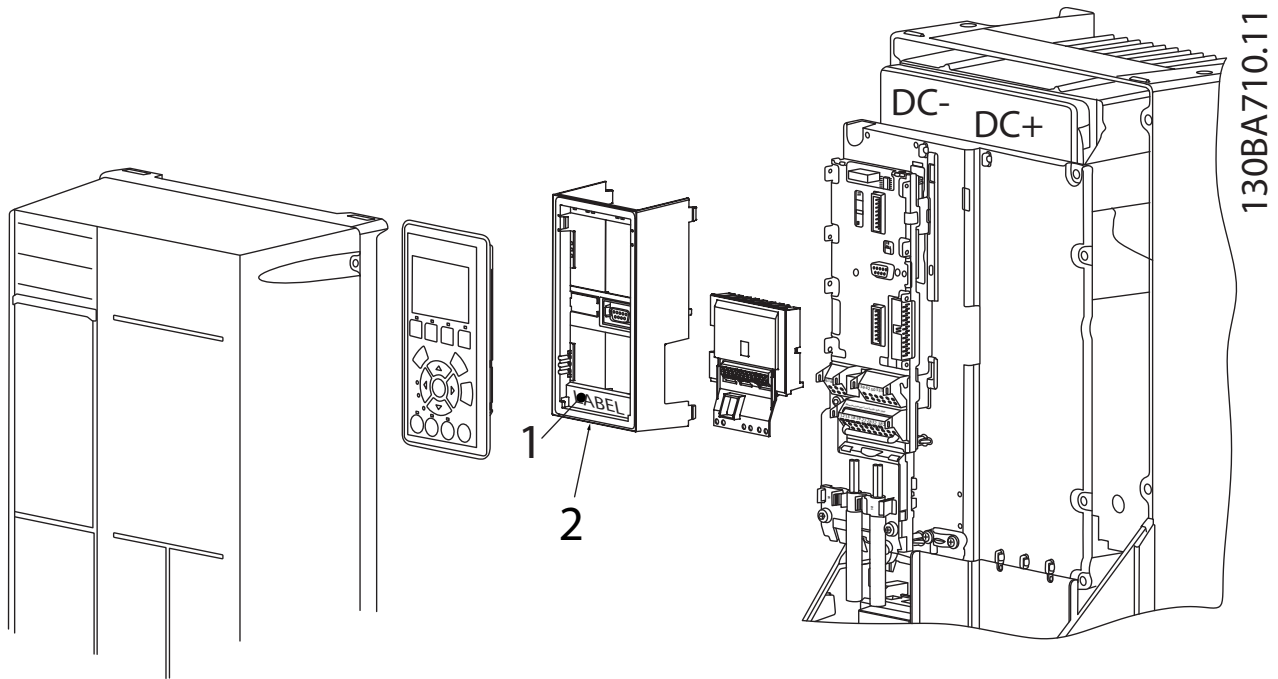

Illustration 3.6 Relay Option Kit

**⚠ WARNING**

Warning Dual supply.

How to add the MCB 105 option:

- See mounting instructions in the beginning of section *Options and Accessories*
- Disconnect power to the live part connections on relay terminals.
- Do not mix live parts with control signals (PELV).
- Select the relay functions in 5-40 *Function Relay* [6-8], 5-41 *On Delay, Relay* [6-8] and 5-42 *Off Delay, Relay* [6-8].

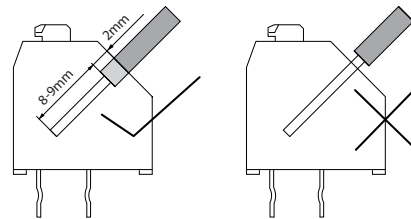

Illustration 3.8 Mounting

130BA177.10

**NOTICE**

Index [6] is relay 7, index [7] is relay 8, and index [8] is relay 9

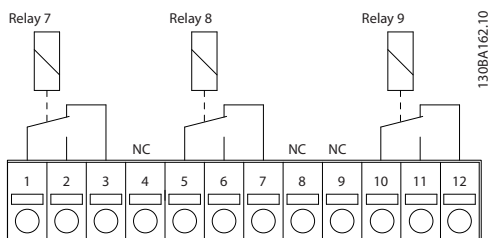

Illustration 3.7 Relay 7, Relay 8, and Relay 9

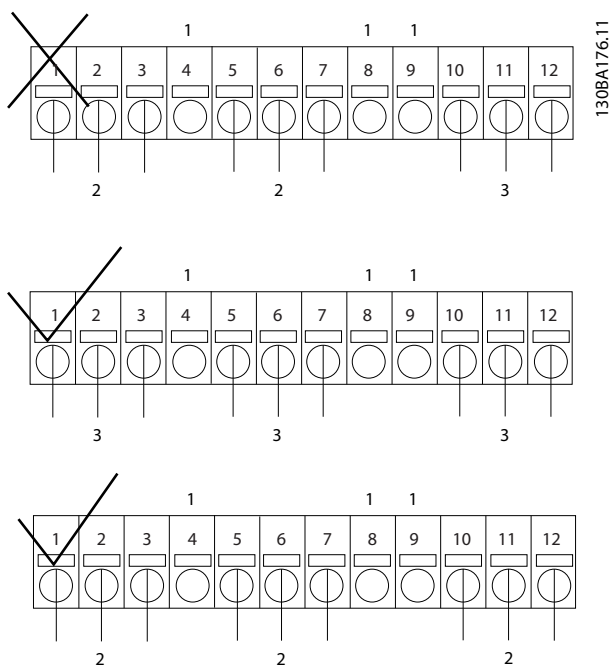

Illustration 3.9 Connection

1	NC
2	Live part
3	PELV

Table 3.6 Legend to Illustration 3.9

**⚠ WARNING**

Do not combine low voltage parts and PELV systems. At a single fault the whole system might become dangerous to touch, and it could result in death or serious injury.

3.1.8 24 V Back-Up Option MCB 107 (Option D)

External 24 V DC Supply

An external 24 V DC supply can be installed for low-voltage supply to the control card and any option card installed. This enables full operation of the LCP (including the parameter setting) and fieldbusses without mains supplied to the power section.

Input voltage range	24 V DC $\pm 15\%$ (max. 37 V in 10 s)
Max. input current	2.2 A
Average input current for the frequency converter	0.9 A
Max cable length	75 m
Input capacitance load	<10 $\mu$ F
Power-up delay	<0.6 s

Table 3.7 External 24 V DC Supply Specification

The inputs are protected.

Terminal numbers:

Terminal 35: - external 24 V DC supply.

Terminal 36: + external 24 V DC supply.

Follow these steps:

1. Remove the LCP or blind cover.
2. Remove the terminal cover.
3. Remove the cable de-coupling plate and the plastic cover underneath.
4. Insert the 24 V DC back-up external supply option in the option slot.
5. Mount the cable de-coupling plate.
6. Attach the terminal cover and the LCP or blind cover.

When , 24 V back-up option MCB 107 supplies the control circuit, the internal 24 V supply is automatically disconnected.

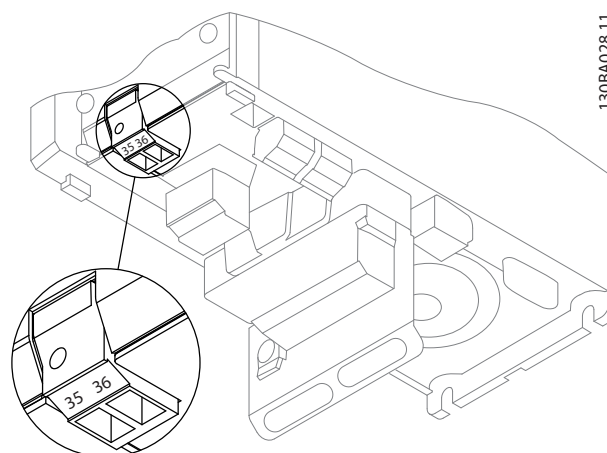

Illustration 3.10 Connection to 24 V Back-up Supplier (A2-A3).

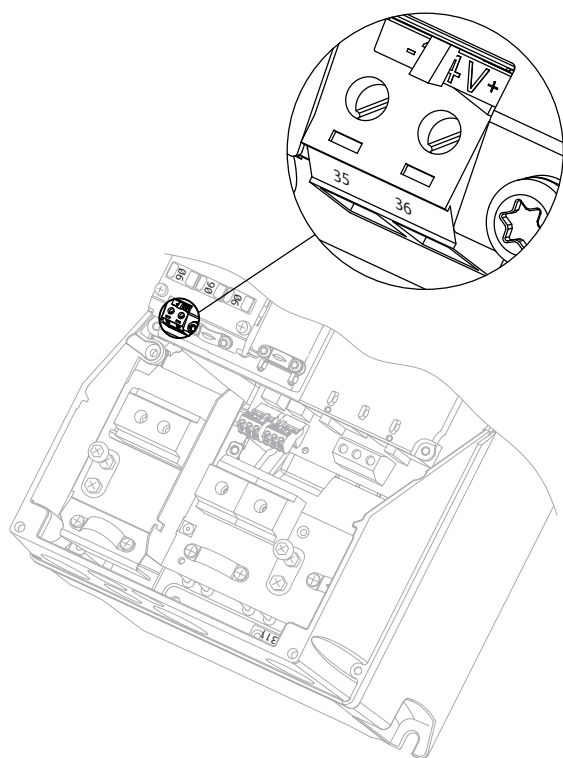
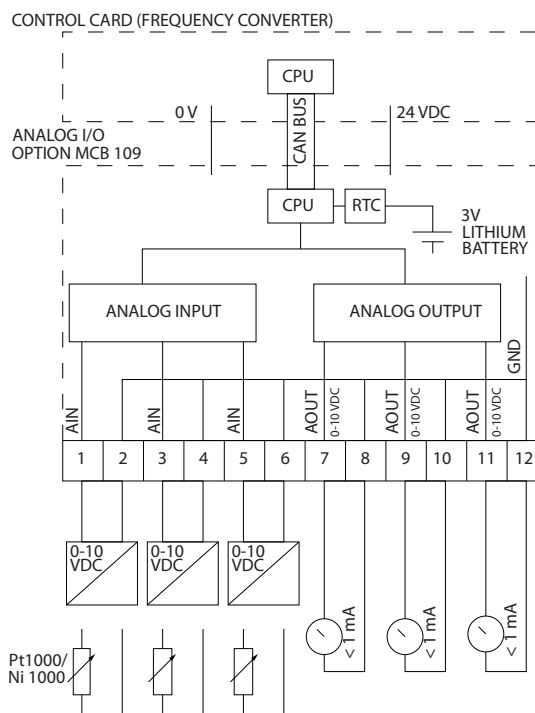

Illustration 3.11 Connection to 24 V Back-up Supplier (A5-C2).

130BA216.10



130BA405.11

Illustration 3.12 Principle Diagram for Analog I/O Mounted in Frequency Converter.

### 3.1.9 Analog I/O option MCB 109

The Analog I/O card is to be used in e.g. the following cases:

- Providing battery back-up of clock function on control card
- As general extension of analog I/O selection available on control card, e.g. for multi-zone control with 3 pressure transmitters
- Turning frequency converter into de-central I/O block supporting Building Management System with inputs for sensors and outputs for operating dampers and valve actuators
- Support Extended PID controllers with I/Os for set point inputs, transmitter/sensor inputs and outputs for actuators.

#### Analog I/O configuration

3 x analog inputs, capable of handling following:

- 0-10 V DC
- OR
- 0-20 mA (voltage input 0-10 V) by mounting a 510  $\Omega$  resistor across terminals (see **NOTICE**)
  - 4-20 mA (voltage input 2-10 V) by mounting a 510  $\Omega$  resistor across terminals (see **NOTICE**)
  - Ni1000 temperature sensor of 1000  $\Omega$  at 0° C. Specifications according to DIN43760
  - Pt1000 temperature sensor of 1000  $\Omega$  at 0° C. Specifications according to IEC 60751

3 x Analog Outputs supplying 0-10 V DC.

## NOTICE

Note the values available within the different standard groups of resistors:

E12: Closest standard value is 470  $\Omega$ , creating an input of 449.9  $\Omega$  and 8.997 V.

E24: Closest standard value is 510  $\Omega$ , creating an input of 486.4  $\Omega$  and 9.728 V.

E48: Closest standard value is 511  $\Omega$ , creating an input of 487.3  $\Omega$  and 9.746 V.

E96: Closest standard value is 523  $\Omega$ , creating an input of 498.2  $\Omega$  and 9.964 V.

### Analog inputs - terminal X42/1-6

Parameter group: 18-3\*. See also *VLT<sup>®</sup> HVAC Drive Programming Guide*.

Parameter groups for set-up: 26-0\*, 26-1\*, 26-2\* and 26-3\*. See also *VLT<sup>®</sup> HVAC Drive Programming Guide*.

3 x Analog inputs	Used as temperature sensor input	Used as voltage input
<b>Operating range</b>	-50 to +150 °C	0 - 10 V DC
<b>Resolution</b>	11 bits	10 bits
<b>Accuracy</b>	-50 °C ±1 Kelvin +150 °C ±2 Kelvin	0.2% of full scale at cal. temperature
<b>Sampling</b>	3 Hz	2.4 Hz
<b>Max load</b>	-	± 20 V continuously
<b>Impedance</b>	-	Approximately 5 k $\Omega$

Table 3.8 Analog inputs - terminal X42/1-6

When used for voltage, analog inputs are scalable by parameters for each input.

When used for temperature sensor, analog inputs scaling is preset to necessary signal level for specified temperature span.

When analog inputs are used for temperature sensors, it is possible to read out feedback value in both °C and °F.

When operating with temperature sensors, maximum cable length to connect sensors is 80 m non-screened/non-twisted wires.

### Analog outputs - terminal X42/7-12

Parameter group: 18-3\*. See also *VLT<sup>®</sup> HVAC Drive Programming Guide*.

Parameter groups for set-up: 26-4\*, 26-5\* and 26-6\*. See also *VLT<sup>®</sup> HVAC Drive Programming Guide*.

3 x Analog outputs	Output signal level	Resolution	Linearity	Max load
Volt	0-10 V DC	11 bits	1% of full scale	1 mA

Table 3.9 Analog outputs - terminal X42/7-12

Analog outputs are scalable by parameters for each output.

The function assigned is selectable via a parameter and have same options as for analog outputs on control card.

For a more detailed description of parameters, refer to the *VLT<sup>®</sup> HVAC Drive Programming Guide*.

### Real-time clock (RTC) with back-up

The data format of RTC includes year, month, date, hour, minutes and weekday.

Accuracy of clock is better than  $\pm 20$  ppm at 25 °C.

The built-in lithium back-up battery lasts on average for minimum 10 years, when frequency converter is operating at 40 °C ambient temperature. If battery pack back-up fails, analog I/O option must be exchanged.

### 3.1.10 PTC Thermistor Card MCB 112

The MCB 112 option makes it possible to monitor the temperature of an electrical motor through a galvanically isolated PTC thermistor input. It is a B option for frequency converter with Safe Torque Off.

For information on mounting and installation of the option, see *chapter 3.1.1 Mounting of Option Modules in Slot B*. See also *chapter 7 Application Examples* for different application possibilities.

X44/1 and X44/2 are the thermistor inputs. X44/12 enables Safe Torque Off of the frequency converter (T-37), if the thermistor values make it necessary, and X44/10 informs the frequency converter that a request for safe torque off came from the MCB 112 to ensure a suitable alarm handling. One of the digital inputs parameters (or a digital input of a mounted option) must be set to [80] *PTC Card 1* to use the information from X44/10. Configure *5-19 Terminal 37 Safe Stop* to the desired Safe Torque Off functionality (default is Safe Stop Alarm).

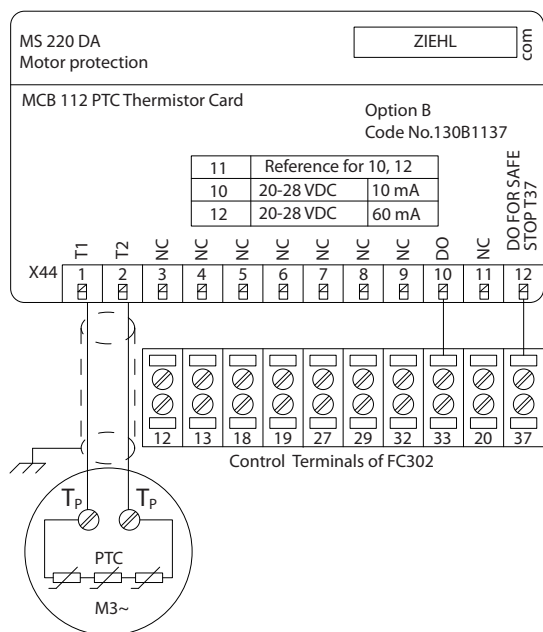

Illustration 3.13 Installation of MCB 112

130BA638:10

**ATEX Certification with FC 102**

The MCB 112 has been certified for ATEX, which means that the frequency converter with the MCB 112 can now be used with motors in potentially explosive atmospheres. See the Operating Instructions for the MCB 112 for more information.



Illustration 3.14 ATMosphere EXplosive (ATEX)

3

**Electrical Data**

**Resistor connection**

PTC compliant with DIN 44081 and DIN 44082

Number	1..6 resistors in series
Shut-off value	3.3 Ω... 3.65 Ω ... 3.85 Ω
Reset value	1.7 Ω ... 1.8 Ω ... 1.95 Ω
Trigger tolerance	± 6 °C
Collective resistance of the sensor loop	< 1.65 Ω
Terminal voltage	≤ 2.5 V for R ≤ 3.65 Ω, ≤ 9 V for R = ∞
Sensor current	≤ 1 mA
Short circuit	20 Ω ≤ R ≤ 40 Ω
Power consumption	60 mA

**Testing conditions**

EN 60 947-8	
Measurement voltage surge resistance	6000 V
Overvoltage category	III
Pollution degree	2
Measurement isolation voltage Vbis	690 V
Reliable galvanic isolation until Vi	500 V
Perm. ambient temperature	-20 °C ... +60 °C
Moisture	EN 60068-2-1 Dry heat
	5-95%, no condensation permissible
EMC resistance	EN61000-6-2
EMC emissions	EN61000-6-4
Vibration resistance	10 ... 1000 Hz 1.14 g
Shock resistance	50 g

**Safety system values**

EN 61508 for Tu = 75 °C ongoing	
SIL	2 for maintenance cycle of 2 years
	1 for maintenance cycle of 3 years

HFT	0
PFD (for yearly functional test)	4.10 *10 <sup>-3</sup>
SFF	78%
$\lambda_s + \lambda_{DD}$	8494 FIT
$\lambda_{DU}$	934 FIT
Ordering number 130B1137	

### 3.1.11 Sensor Input Option MCB 114

The sensor input option card MCB 114 can be used in the following cases:

- Sensor input for temperature transmitters PT100 and PT1000 for monitoring bearing temperatures
- As general extension of analog inputs with one additional input for multi-zone control or differential pressure measurements
- Support extended PID controllers with I/Os for set point, transmitter/sensor inputs

Typical motors, designed with temperature sensors for protecting bearings from being overloaded, are fitted with 3 PT100/1000 temperature sensors. One in front, one in the back-end bearing, and one in the motor windings. The sensor input Option MCB 114 supports 2- or 3-wire sensors with individual temperature limits for under/over temperature. An auto detection of sensor type, PT100 or PT1000 takes place at power up.

The option can generate an alarm if the measured temperature is either below low limit or above high limit specified by the user. The individual measured temperature on each sensor input can be read out in the display or by readout parameters. If an alarm occurs, the relays or digital outputs can be programmed to be active high by selecting [21] *Thermal Warning* in parameter group 5-\*\*.

A fault condition has a common warning/alarm number associated with it, which is Alarm/Warning 20, Temp. input error. Any present output can be programmed to be active in case the warning or alarm appears.

#### 3.1.11.1 Ordering Code Numbers and Parts Delivered

Standard version code no: 130B1172.  
Coated version code no: 130B1272.

### 3.1.11.2 Electrical and Mechanical Specifications

#### Analog Input

Number of analog inputs	1
Format	0-20 mA or 4-20 mA
Wires	2
Input impedance	<200 $\Omega$
Sample rate	1 kHz
3rd order filter	100 Hz at 3 dB

The option is able to supply the analog sensor with 24V DC (terminal 1).

#### Temperature Sensor Input

Number of analog inputs supporting PT100/1000	3
Signal type	PT100/1000
Connection	PT 100 2 or 3 wire/PT1000 2 or 3 wire
Frequency PT100 and PT1000 input	1Hz for each channel
Resolution	10 bit
Temperature range	-50 - 204 °C -58 - 399 °F

#### Galvanic Isolation

The sensors to be connected are expected to be galvanically isolated from the mains voltage level IEC 61800-5-1 and UL508C

#### Cabling

Maximum signal cable length	500 m
-----------------------------	-------

### 3.1.11.3 Electrical Wiring

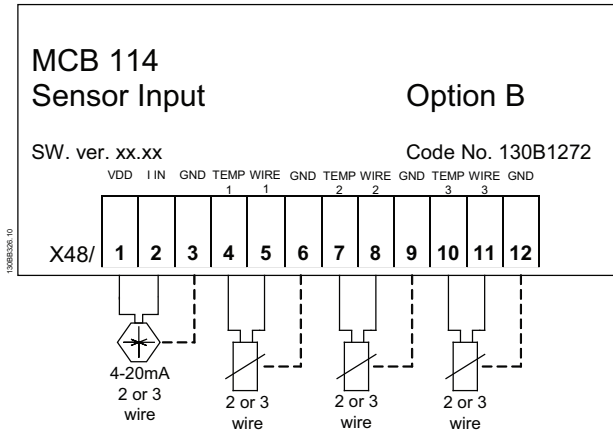

Illustration 3.15 Electrical Wiring

Terminal	Name	Function
1	VDD	24V DC to supply 4-20mA sensor
2	I in	4-20mA input
3	GND	Analog input GND
4, 7, 10	Temp 1, 2, 3	Temperature input
5, 8, 11	Wire 1, 2, 3	3 <sup>rd</sup> wire input if 3 wire sensors are used
6, 9, 12	GND	Temp. input GND

Table 3.10 Terminals

### 3.1.12 Remote Mounting Kit for LCP

The LCP can be moved to the front of a cabinet by using the remote built-in kit. The enclosure is the IP66. The fastening screws must be tightened with a torque of max. 1 Nm.

Enclosure	IP66 front
Max. cable length between and unit	3 m
Communication std	RS-485

Table 3.11 Technical Data

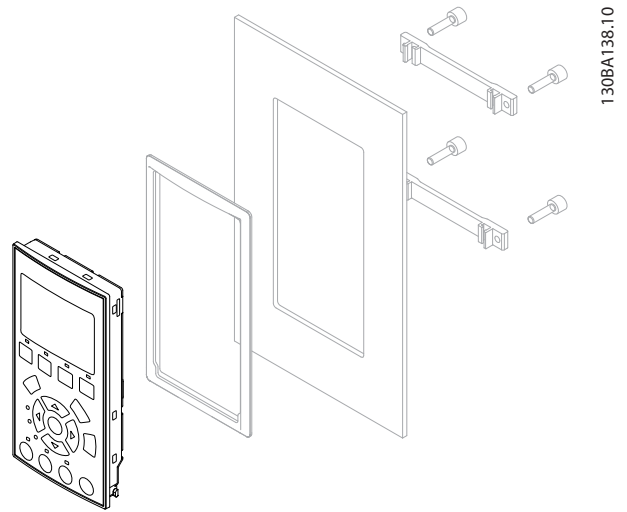

Illustration 3.16 LCP Kit with Graphical LCP, Fasteners, 3 m Cable and Gasket  
Ordering No. 130B1113

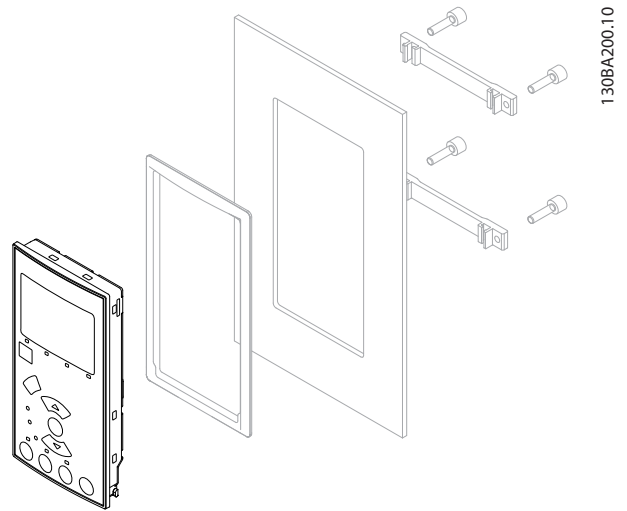

Illustration 3.17 LCP Kit with Numerical LCP, Fasteners and Gasket  
Ordering no. 130B1114

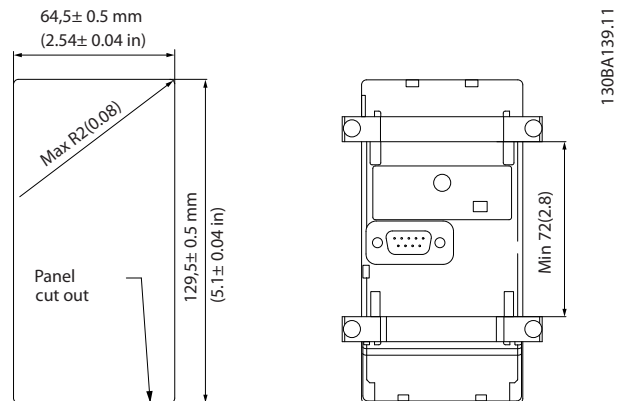

Illustration 3.18 Dimensions

### 3.1.13 IP21/IP41/ TYPE1 Enclosure Kit

IP21/IP41 top/ TYPE 1 is an optional enclosure element available for IP20 compact units, enclosure size A2-A3, B3+B4 and C3+C4.

If the enclosure kit is used, an IP20 unit is upgraded to comply with enclosure IP21/41 top/TYPE 1.

The IP41 top can be applied to all standard IP20 VLT® HVAC Drive variants.

### 3.1.14 IP21/Type 1 Enclosure Kit

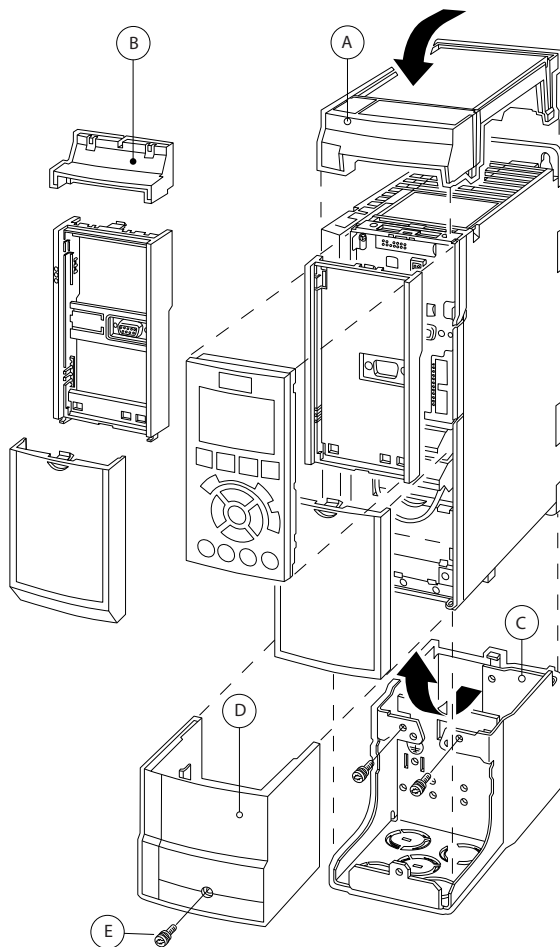

Illustration 3.19 Enclosure Type A2

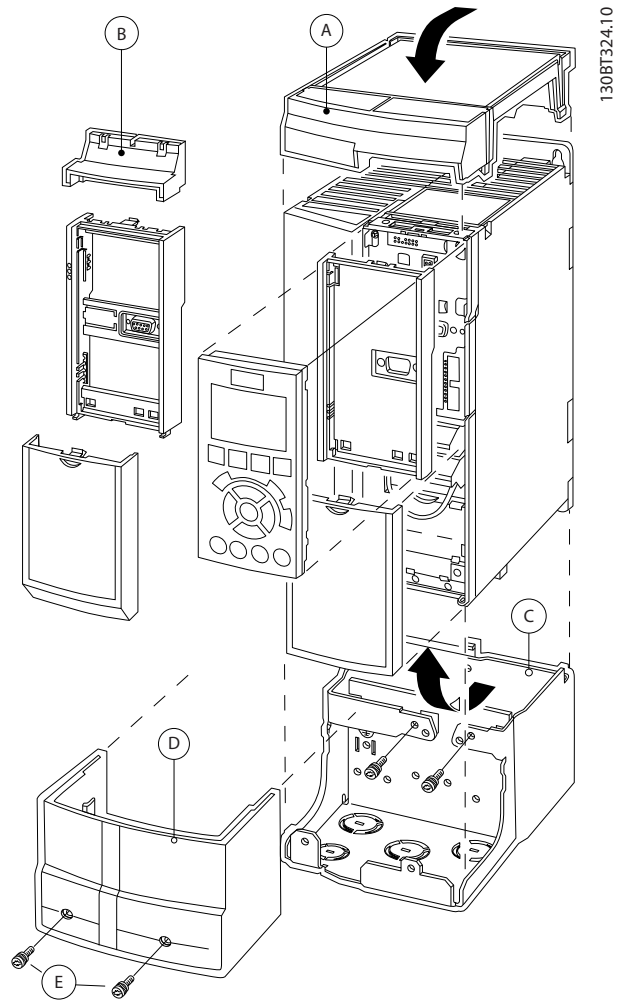

Illustration 3.20 Enclosure Type A3

A	Top cover
B	Brim
C	Base part
D	Base cover
E	Screw(s)

Table 3.12 Legend to Illustration 3.19 and Illustration 3.20

Place the top cover as shown. If an A or B option is used the brim must be fitted to cover the top inlet. Place the base part C at the bottom of the frequency converter and use the clamps from the accessory bag to correctly fasten the cables. Holes for cable glands:

Size A2: 2x M25 and 3xM32

Size A3: 3xM25 and 3xM32



Enclosure type	Height A [mm]	Width B [mm]	Depth C* [mm]
A2	372	90	205
A3	372	130	205
B3	475	165	249
B4	670	255	246
C3	755	329	337
C4	950	391	337

Table 3.13 Dimensions

\* If option A/B is used, the depth increases (see chapter 5.1.2 Mechanical Dimensions for details)

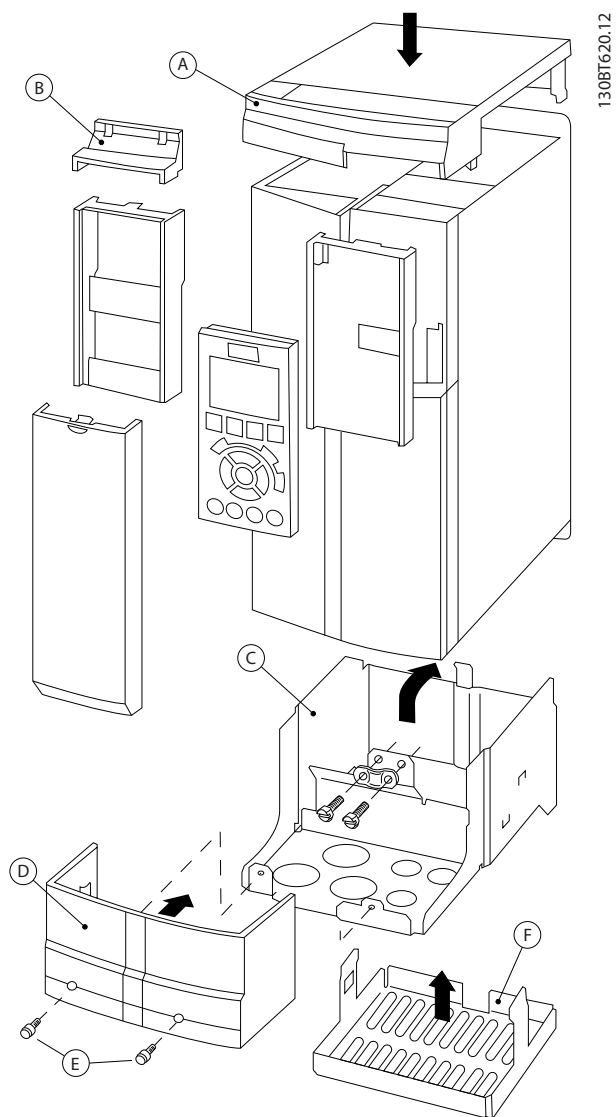

Illustration 3.21 Enclosure Type B3

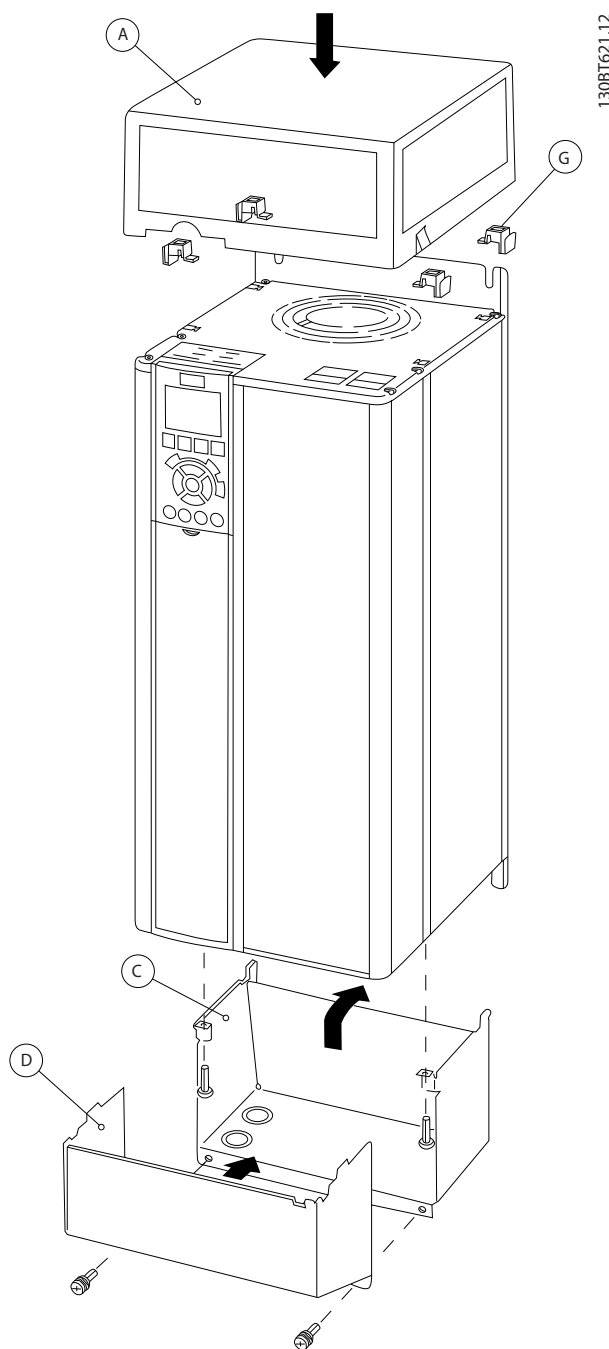

Illustration 3.22 Enclosure Types B4 - C3 - C4

A	Top cover
B	Brim
C	Base part
D	Base cover
E	Screw(s)
F	Fan cover
G	Top clip

Table 3.14 Legend to Illustration 3.21 and Illustration 3.22

When option module A and/or option module B is/are used, the brim (B) must be fitted to the top cover (A).

### **NOTICE**

Side-by-side installation is not possible when using the IP21/IP4X/TYPE 1 Enclosure Kit

**3**

#### 3.1.15 Output Filters

The high speed switching of the frequency converter produces some secondary effects, which influence the motor and the enclosed environment. These side effects are addressed by 2 different filter types, the dU/dt and the sine-wave filter.

##### **dU/dt filters**

Motor insulation stresses are often caused by the combination of rapid voltage and current increase. The rapid energy changes can also be reflected back to the DC-line in the inverter and cause shut down. The dU/dt filter is designed to reduce the voltage rise time/the rapid energy change in the motor and by that intervention avoid premature aging and flashover in the motor insulation. dU/dt filters have a positive influence on the radiation of magnetic noise in the cable that connects the frequency converter to the motor. The voltage wave form is still pulse shaped but the dU/dt ratio is reduced in comparison with the installation without filter.

##### **Sine-wave filters**

Sine-wave filters are designed to let only low frequencies pass. High frequencies are consequently shunted away which results in a sinusoidal phase to phase voltage waveform and sinusoidal current waveforms. With the sinusoidal waveforms the use of special frequency converter motors with reinforced insulation is no longer needed. The acoustic noise from the motor is also damped as a consequence of the wave condition. Besides the features of the dU/dt filter, the sine-wave filter also reduces insulation stress and bearing currents in the motor thus leading to prolonged motor lifetime and longer periods between services. Sine-wave filters enable use of longer motor cables in applications where the motor is installed far from the frequency converter. The length is unfortunately limited because the filter does not reduce leakage currents in the cables.

## 4 How to Order

### 4.1 Ordering Form

#### 4.1.1 Drive Configurator

It is possible to design a frequency converter according to the application requirements by using the ordering number system.

Order the frequency converter as either standard or with integral options by sending a type code string describing the product a to the local Danfoss sales office, i.e.:

FC-102P18KT4E21H1XGCXXXSXXXAGBKCXXXXX

The meaning of the characters in the string can be located in the pages containing the ordering numbers in *chapter 3 Selection*. In the example above, a Profibus LON works option and a General purpose I/O option is included in the frequency converter.

Ordering numbers for frequency converter standard variants can also be located in *chapter 4 How to Order*.

Configure the right frequency converter for the right application and generate the type code string in the Internet-based Drive Configurator. The Drive Configurator automatically generates an 8-digit sales number to be delivered to the local sales office.

Furthermore, establish a project list with several products and send it to a Danfoss sales representative.

The Drive Configurator can be found on the global Internet site: [www.danfoss.com/drives](http://www.danfoss.com/drives).

#### Example of Drive Configurator interface set-up:

The numbers shown in the boxes refer to the letter/figure number of the Type Code String - read from left to right.

Product groups	1-3	
Frequency converter series	4-6	
Power rating	8-10	
Phases	11	
Mains Voltage	12	
Enclosure	13-15	
Enclosure type		
Enclosure class		
Control supply voltage		
Hardware configuration		
RFI filter	16-17	
Brake	18	
Display (LCP)	19	

Coating PCB	20	
Mains option	21	
Adaptation A	22	
Adaptation B	23	
Software release	24-27	
Software language	28	
A options	29-30	
B options	31-32	
C0 options, MCO	33-34	
C1 options	35	
C option software	36-37	
D options	38-39	

Table 4.1 Example of Drive Configurator Interface Set-up

### 4.1.2 Type Code String Low and Medium Power

1 2 3 4 5 6 7 8 9 10 11 12 13 14 15 16 17 18 19 20 21 22 23 24 25 26 27 28 29 30 31 32 33 34 35 36 37 38 39  
 F C - 0 P T H X X S X X X X A B C D

130BA052.14

Illustration 4.1 Type Code String

4

Description	Pos.	Possible choice
Product group & FC Series	1-6	FC 102
Power rating	8-10	1.1- 90 kW (P1K1 - P90K)
Number of phases	11	3 phases (T)
Mains voltage	11-12	T 2: 200-240 V AC T 4: 380-480 V AC T 6: 525-600 V AC T 7: 525-690 V AC
Enclosure	13-15	E20: IP20 E21: IP21/NEMA Type 1 E55: IP55/NEMA Type 12 E66: IP66 P21: IP21/NEMA Type 1 w/ backplate P55: IP55/NEMA Type 12 w/ backplate Z55: A4 Frame IP55 Z66: A4 Frame IP66
RFI filter	16-17	H1: RFI filter class A1/B H2: RFI filter class A2 H3: RFI filter class A1/B (reduced cable length) Hx: No RFI filter
Brake	18	X: No brake chopper included B: Brake chopper included T: Safe Stop U: Safe + brake
Display	19	G: Graphical Local Control Panel (GLCP) N: Numeric Local Control Panel (NLCP) X: No Local Control Panel
Coating PCB	20	X: No coated PCB C: Coated PCB
Mains option	21	X: No Mains disconnect switch and Load Sharing 1: With Mains disconnect switch (IP55 only) 8: Mains disconnect and Load Sharing D: Load Sharing See Chapter 9 for max. cable sizes.

Description	Pos.	Possible choice
Adaptation	22	X: Standard cable entries O: European metric thread in cable entries (A4, A5, B1, B2 only) S: Imperial cable entries (A5, B1, B2 only)
Adaptation	23	Reserved
Software release	24-27	Actual software
Software language	28	
A options	29-30	AX: No options A0: MCA 101 Profibus DP V1 A4: MCA 104 DeviceNet AG: MCA 108 Lonworks AJ: MCA 109 BACnet gateway AL: MCA 120 Profinet AN: MCA 121 EtherNet/IP AQ: MCA 122 Modbus TCP
B options	31-32	BX: No option BK: MCB 101 General purpose I/O option BP: MCB 105 Relay option BO: MCB 109 Analog I/O option B2: MCB 112 PTC Thermistor Card B4: MCB 114 Sensor input option
C0 options MCO	33-34	CX: No options
C1 options	35	X: No options
C option software	36-37	XX: Standard software
D options	38-39	DX: No option D0: 24 V back- up

Table 4.2 Type Code Description

## 4.2 Ordering Numbers

### 4.2.1 Ordering Numbers: Options and Accessories

Type	Description	Ordering no.
<b>Miscellaneous hardware I</b>		
DC-link connector	Terminal block for DC-link connection on A2/A3	130B1064
IP 21/4X top/TYPE 1 kit	IP21/NEMA1 Top + bottom A2	130B1122
IP 21/4X top/TYPE 1 kit	IP21/NEMA1 Top + bottom A3	130B1123
IP 21/4X top/TYPE 1 kit	IP21/NEMA1 Top + bottom B3	130B1187
IP 21/4X top/TYPE 1 kit	IP21/NEMA1 Top + bottom B4	130B1189
IP 21/4X top/TYPE 1 kit	IP21/NEMA1 Top + bottom C3	130B1191
IP 21/4X top/TYPE 1 kit	IP21/NEMA1 Top + bottom C4	130B1193
IP21/4X top	IP21 Top Cover A2	130B1132
IP21/4X top	IP21 Top Cover A3	130B1133
IP 21/4X top	IP21 Top Cover B3	130B1188
IP 21/4X top	IP21 Top Cover B4	130B1190
IP 21/4X top	IP21 Top Cover C3	130B1192
IP 21/4X top	IP21 Top Cover C4	130B1194
Panel Through Mount Kit	Enclosure, enclosure type A5	130B1028
Panel Through Mount Kit	Enclosure, enclosure type B1	130B1046
Panel Through Mount Kit	Enclosure, enclosure type B2	130B1047
Panel Through Mount Kit	Enclosure, enclosure type C1	130B1048
Panel Through Mount Kit	Enclosure, enclosure type C2	130B1049
Profibus D-Sub 9	Connector kit for IP20	130B1112
Profibus top entry kit	Top entry kit for Profibus connection - D + E enclosure types	176F1742
Terminal blocks	Screw terminal blocks for replacing spring loaded terminals 1 pc 10 pin 1 pc 6 pin and 1 pc 3 pin connectors	130B1116
Backplate	A5 IP55/NEMA 12	130B1098
Backplate	B1 IP21/IP55 / NEMA 12	130B3383
Backplate	B2 IP21/IP55 / NEMA 12	130B3397
Backplate	C1 IP21/IP55 / NEMA 12	130B3910
Backplate	C2 IP21/IP55 / NEMA 12	130B3911
Backplate	A5 IP66	130B3242
Backplate	B1 IP66	130B3434
Backplate	B2 IP66	130B3465
Backplate	C1 IP66	130B3468
Backplate	C2 IP66	130B3491
<b>LCPs and kits</b>		
LCP 101	Numerical Local Control Panel (NLCP)	130B1124
102	Graphical Local Control Panel (GLCP)	130B1107
cable	Separate cable, 3 m	175Z0929
kit	Panel mounting kit including graphical LCP, fasteners, 3 m cable and gasket	130B1113
LCP kit	Panel mounting kit including numerical LCP, fasteners and gasket	130B1114
kit	Panel mounting kit for all LCPs including fasteners, 3 m cable and gasket	130B1117
kit	Front mounting kit, IP55 enclosures	130B1129
kit	Panel mounting kit for all LCPs including fasteners and gasket - without cable	130B1170

**Table 4.3** Options can be ordered as factory built-in options, see ordering information.

Type	Description	Comments
<b>Options for Slot A</b>		<b>Ordering no. Coated</b>
MCA 101	Profibus option DP V0/V1	130B1200
MCA 104	DeviceNet option	130B1202
MCA 108	Lonworks	130B1206
MCA 109	BACnet gateway for build-in. Not to be used with Relay Option MCB 105 card	130B1244
MCA 120	Profinet	130B1135
MCA 121	Ethernet	130B1219
<b>Options for Slot B</b>		
MCB 101	General purpose Input Output option	
MCB 105	Relay option	
MCB 109	Analog I/O option and battery back-up for real-time clock	130B1243
MCB 112	ATEX PTC	130B1137
MCB 114	Sensor input - unocated	130B1172
	Sensor input - coated	130B1272
<b>Option for Slot D</b>		
MCB 107	24 V DC back-up	130B1208
<b>External Options</b>		
Ethernet IP	Ethernet master	

**Table 4.4 Options Ordering Information**

*For information on fieldbus and application option compatibility with older software versions, contact your Danfoss supplier.*

Type	Description	Ordering no.	Comments
<b>Spare Parts</b>			
Control board FC	With Safe Stop Function	130B1150	
Control board FC	Without Safe Stop Function	130B1151	
Fan A2	Fan, enclosure type A2	130B1009	
Fan A3	Fan, enclosure type A3	130B1010	
Fan A5	Fan, enclosure type A5	130B1017	
Fan B1	Fan external, enclosure type B1	130B3407	
Fan B2	Fan external, enclosure type B2	130B3406	
Fan B3	Fan external, enclosure type B3	130B3563	
Fan B4	Fan external, 18.5/22 kW	130B3699	
Fan B4	Fan external 22/30 kW	130B3701	
Fan C1	Fan external, enclosure type C1	130B3865	
Fan C2	Fan external, enclosure type C2	130B3867	
Fan C3	Fan external, enclosure type C3	130B4292	
Fan C4	Fan external, enclosure type C4	130B4294	
<b>Miscellaneous hardware II</b>			
Accessory bag A2	Accessory bag, enclosure type A2	130B1022	
Accessory bag A3	Accessory bag, enclosure type A3	130B1022	
Accessory bag A4	Accessory bag for frame A4 w/o thread	130B0536	
Accessory bag A5	Accessory bag, enclosure type A5	130B1023	
Accessory bag B1	Accessory bag, enclosure type B1	130B2060	
Accessory bag B2	Accessory bag, enclosure type B2	130B2061	
Accessory bag B3	Accessory bag, enclosure type B3	130B0980	
Accessory bag B4	Accessory bag, enclosure type B4	130B1300	Small
Accessory bag B4	Accessory bag, enclosure type B4	130B1301	Big
Accessory bag C1	Accessory bag, enclosure type C1	130B0046	
Accessory bag C2	Accessory bag, enclosure type C2	130B0047	
Accessory bag C3	Accessory bag, enclosure type C3	130B0981	
Accessory bag C4	Accessory bag, enclosure type C4	130B0982	Small
Accessory bag C4	Accessory bag, enclosure type C4	130B0983	Big

Table 4.5 Accessories Ordering Information

### 4.2.2 Ordering Numbers: Harmonic Filters

Harmonic filters are used to reduce mains harmonics.

- AHF 010: 10% current distortion
- AHF 005: 5% current distortion

I <sub>AHF,N</sub> [A]	Typical Motor Used [kW]	Danfoss Ordering Number		Frequency converter size
		AHF 005	AHF 010	
10	1.1-4	175G6600	175G6622	P1K1, P4K0
19	5.5-7.5	175G6601	175G6623	P5K5-P7K5
26	11	175G6602	175G6624	P11K
35	15-18.5	175G6603	175G6625	P15K-P18K
43	22	175G6604	175G6626	P22K
72	30-37	175G6605	175G6627	P30K-P37K
101	45-55	175G6606	175G6628	P45K-P55K
144	75	175G6607	175G6629	P75K
180	90	175G6608	175G6630	P90K
217	110	175G6609	175G6631	P110
289	132	175G6610	175G6632	P132-P160
324	160	175G6611	175G6633	
370	200	175G6688	175G6691	P200
506	250	175G6609 + 175G6610	175G6631 + 175G6632	P250
578	315	2x 175G6610	2x 175G6632	P315
648	355	2x175G6611	2x175G6633	P355
694	400	175G6611 + 175G6688	175G6633 + 175G6691	P400
740	450	2x175G6688	2x175G6691	P450

Table 4.6 380-415 V AC, 50 Hz

I <sub>AHF,N</sub> [A]	Typical Motor Used [hp]	Danfoss Ordering Number		Frequency converter size
		AHF 005	AHF 010	
10	1.1-4	130B2540	130B2541	P1K1-P4K0
19	5.5-7.5	130B2460	130B2472	P5K5-P7K5
26	11	130B2461	130B2473	P11K
35	15-18.5	130B2462	130B2474	P15K, P18K
43	22	130B2463	130B2475	P22K
72	30-37	130B2464	130B2476	P30K-P37K
101	45-55	130B2465	130B2477	P45K-P55K
144	75	130B2466	130B2478	P75K
180	90	130B2467	130B2479	P90K
217	110	130B2468	130B2480	P110
289	132	130B2469	130B2481	P132
324	160	130B2470	130B2482	P160
370	200	130B2471	130B2483	P200
506	250	130B2468 + 130B2469	130B2480 + 130B2481	P250
578	315	2x 130B2469	2x 130B2481	P315
648	355	2x130B2470	2x130B2482	P355
694	400	130B2470 + 130B2471	130B2482 + 130B2483	P400
740	450	2x130B2471	130B2483	P450

Table 4.7 380-415 V AC, 60 Hz



I <sub>AHF,N</sub> [A]	Typical Motor Used [hp]	Danfoss Ordering Number		Frequency converter size
		AHF 005	AHF 010	
10	1.5-7.5	130B2538	130B2539	P1K1-P5K5
19	10-15	175G6612	175G6634	P7K5-P11K
26	20	175G6613	175G6635	P15K
35	25-30	175G6614	175G6636	P18K-P22K
43	40	175G6615	175G6637	P30K
72	50-60	175G6616	175G6638	P37K-P45K
101	75	175G6617	175G6639	P55K
144	100-125	175G6618	175G6640	P75K-P90K
180	150	175G6619	175G6641	P110
217	200	175G6620	175G6642	P132
289	250	175G6621	175G6643	P160
370	350	175G6690	175G6693	P200
434	350	2x175G6620	2x175G6642	P250
506	450	175G6620 + 175G6621	175G6642 + 175G6643	P315
578	500	2x 175G6621	2x 175G6643	P355
648	550-600	2x175G6689	2x175G6692	P400
694	600	175G6689 + 175G6690	175G6692 + 175G6693	P450
740	650	2x175G6690	2x175G6693	P500

Table 4.8 440-480 V AC, 60 Hz

Matching the frequency converter and filter is pre-calculated based on 400 V/480 V and on a typical motor load (4 pole) and 110 % torque.

I <sub>AHF,N</sub> [A]	Typical Motor Used [kW]	Danfoss Ordering Number		Frequency converter size
		AHF 005	AHF 010	
10	1.1-7.5	175G6644	175G6656	P1K1-P7K5
19	11	175G6645	175G6657	P11K
26	15-18.5	175G6646	175G6658	P15K-P18K
35	22	175G6647	175G6659	P22K
43	30	175G6648	175G6660	P30K
72	37-45	175G6649	175G6661	P45K-P55K
101	55	175G6650	175G6662	P75K
144	75-90	175G6651	175G6663	P90K-P110
180	110	175G6652	175G6664	P132
217	132	175G6653	175G6665	P160
289	160-200	175G6654	175G6666	P200-P250
324	250	175G6655	175G6667	P315
397	315	175G6652 + 175G6653	175G6641 + 175G6665	P400
434	355	2x175G6653	2x175G6665	P450
506	400	175G6653 + 175G6654	175G6665 + 175G6666	P500
578	450	2X 175G6654	2X 175G6666	P560
613	500	175G6654 + 175G6655	175G6666 + 175G6667	P630

Table 4.9 500-525 V AC, 50 Hz

I <sub>AHF,N</sub> [A]	Typical Motor Used [kW]	Danfoss Ordering Number		Frequency converter size
		AHF 005	AHF 010	
43	45	130B2328	130B2293	
72	45-55	130B2330	130B2295	P37K-P45K
101	75-90	130B2331	130B2296	P55K-P75K
144	110	130B2333	130B2298	P90K-P110
180	132	130B2334	130B2299	P132
217	160	130B2335	130B2300	P160
288	200-250	2x130B2333	130B2301	P200-P250
324	315	130B2334 + 130B2335	130B2302	P315
397	400	130B2334 + 130B2335	130B2299 + 130B2300	P400
434	450	2x130B2335	2x130B2300	P450
505	500	*	130B2300 + 130B2301	P500
576	560	*	2x130B2301	P560
612	630	*	130B2301 + 130B2300	P630
730	710	*	2x130B2302	P710

Table 4.10 690 VAC, 50 Hz

\* For higher currents, contact Danfoss.

### 4.2.3 Ordering Numbers: Sine Wave Filter Modules, 200-500 V AC

Frequency Converter Size			Minimum switching frequency [kHz]	Maximum output frequency [Hz]	Part No. IP20	Part No. IP00	Rated filter current at 50 Hz [A]
200-240 [V AC]	380-440 [V AC]	440-480 [V AC]					
	P1K1	P1K1	5	120	130B2441	130B2406	4.5
	P1K5	P1K5	5	120	130B2441	130B2406	4.5
	P2K2	P2K2	5	120	130B2443	130B2408	8
P1K5	P3K0	P3K0	5	120	130B2443	130B2408	8
	P4K0	P4K0	5	120	130B2444	130B2409	10
P2K2	P5K5	P5K5	5	120	130B2446	130B2411	17
P3K0	P7K5	P7K5	5	120	130B2446	130B2411	17
P4K0			5	120	130B2446	130B2411	17
P5K5	P11K	P11K	4	100	130B2447	130B2412	24
P7K5	P15K	P15K	4	100	130B2448	130B2413	38
	P18K	P18K	4	100	130B2448	130B2413	38
P11K	P22K	P22K	4	100	130B2307	130B2281	48
P15K	P30K	P30K	3	100	130B2308	130B2282	62
P18K	P37K	P37K	3	100	130B2309	130B2283	75
P22K	P45K	P55K	3	100	130B2310	130B2284	115
P30K	P55K	P75K	3	100	130B2310	130B2284	115
P37K	P75K	P90K	3	100	130B2311	130B2285	180
P45K	P90K	P110	3	100	130B2311	130B2285	180
	P110	P132	3	100	130B2312	130B2286	260
	P132	P160	3	100	130B2313	130B2287	260
	P160	P200	3	100	130B2313	130B2287	410
	P200	P250	3	100	130B2314	130B2288	410
	P250	P315	3	100	130B2314	130B2288	480
	P315	P315	2	100	130B2315	130B2289	660
	P355	P355	2	100	130B2315	130B2289	660
	P400	P400	2	100	130B2316	130B2290	750
		P450	2	100	130B2316	130B2290	750
	P450	P500	2	100	130B2317	130B2291	880
	P500	P560	2	100	130B2317	130B2291	880
	P560	P630	2	100	130B2318	130B2292	1200
	P630	P710	2	100	130B2318	130B2292	1200
	P710	P800	2	100	2x130B2317	2x130B2291	1500
	P800	P1M0	2	100	2x130B2317	2x130B2291	1500
	P1M0		2	100	2x130B2318	2x130B2292	1700

Table 4.11 Mains Supply 3x200 to 480 V AC

When using Sine-wave filters, the switching frequency should comply with filter specifications in *14-01 Switching Frequency*.

**NOTICE**

See also *Output Filter Design Guide*.

## 4.2.4 Ordering Numbers: Sine-Wave Filter Modules, 525-600/690 V AC

Frequency Converter Size		Minimum switching frequency [kHz]	Maximum output frequency [Hz]	Part No. IP20	Part No. IP00	Rated filter current at 50 Hz [A]
525-600 [V AC]	690 [V AC]					
P1K1		2	100	130B2341	130B2321	13
P1K5		2	100	130B2341	130B2321	13
P2k2		2	100	130B2341	130B2321	13
P3K0		2	100	130B2341	130B2321	13
P4K0		2	100	130B2341	130B2321	13
P5K5		2	100	130B2341	130B2321	13
P7K5		2	100	130B2341	130B2321	13
P11K		2	100	130B2342	130B2322	28
P15K		2	100	130B2342	130B2322	28
P18K		2	100	130B2342	130B2322	28
P22K		2	100	130B2342	130B2322	28
P30K		2	100	130B2343	130B2323	45
P37K	P45K	2	100	130B2344	130B2324	76
P45K	P55K	2	100	130B2344	130B2324	76
P55K	P75K	2	100	130B2345	130B2325	115
P75K	P90K	2	100	130B2345	130B2325	115
P90K	P110	2	100	130B2346	130B2326	165
	P132	2	100	130B2346	130B2326	165
	P160	2	100	130B2347	130B2327	260
	P200	2	100	130B2347	130B2327	260
	P250	2	100	130B2348	130B2329	303
	P315	2	100	130B2370	130B2341	430
	P355	1.5	100	130B2370	130B2341	430
	P400	1.5	100	130B2370	130B2341	430
	P450	1.5	100	130B2371	130B2342	530
	P500	1.5	100	130B2371	130B2342	530
	P560	1.5	100	130B2381	130B2337	660
	P630	1.5	100	130B2381	130B2337	660
	P710	1.5	100	130B2382	130B2338	765
	P800	1.5	100	130B2383	130B2339	940
	P900	1.5	100	130B2383	130B2339	940
	P1M0	1.5	100	130B2384	130B2340	1320
	P1M2	1.5	100	130B2384	130B2340	1320
	P1M4	1.5	100	2x130B2382	2x130B2338	1479

Table 4.12 Mains Supply 3x525-690 V AC

**NOTICE**

When using sine-wave filters, the switching frequency should comply with filter specifications in *14-01 Switching Frequency*.

**NOTICE**

See also *Output Filter Design Guide*.

## 4.2.5 Ordering Numbers: dU/dt Filters, 380-480 V AC

Frequency converter Size		Minimum switching frequency [kHz]	Maximum output frequency [Hz]	Part No. IP20	Part No. IP00	Rated filter current at 50 Hz [A]
380-439 [V AC]	440-480 [V AC]					
P11K	P11K	4	100	130B2396	130B2385	24
P15K	P15K	4	100	130B2397	130B2386	45
P18K	P18K	4	100	130B2397	130B2386	45
P22K	P22K	4	100	130B2397	130B2386	45
P30K	P30K	3	100	130B2398	130B2387	75
P37K	P37K	3	100	130B2398	130B2387	75
P45K	P45K	3	100	130B2399	130B2388	110
P55K	P55K	3	100	130B2399	130B2388	110
P75K	P75K	3	100	130B2400	130B2389	182
P90K	P90K	3	100	130B2400	130B2389	182
P110	P110	3	100	130B2401	130B2390	280
P132	P132	3	100	130B2401	130B2390	280
P160	P160	3	100	130B2402	130B2391	400
P200	P200	3	100	130B2402	130B2391	400
P250	P250	3	100	130B2277	130B2275	500
P315	P315	2	100	130B2278	130B2276	750
P355	P355	2	100	130B2278	130B2276	750
P400	P400	2	100	130B2278	130B2276	750
	P450	2	100	130B2278	130B2276	750
P450	P500	2	100	130B2405	130B2393	910
P500	P560	2	100	130B2405	130B2393	910
P560	P630	2	100	130B2407	130B2394	1500
P630	P710	2	100	130B2407	130B2394	1500
P710	P800	2	100	130B2407	130B2394	1500
P800	P1M0	2	100	130B2407	130B2394	1500
P1M0		2	100	130B2410	130B2395	2300

Table 4.13 Mains supply 3x380 to 3x480 V AC

**NOTICE**

 See also *Output Filter Design Guide*.

## 4.2.6 Ordering Numbers: dU/dt Filters, 525-600/690 V AC

Frequency converter Size		Minimum switching frequency [kHz]	Maximum output frequency [Hz]	Part No. IP20	Part No. IP00	Rated filter current at 50 Hz [A]
525-600 [V AC]	690 [V AC]					
P1K1		4	100	130B2423	130B2414	28
P1K5		4	100	130B2423	130B2414	28
P2K2		4	100	130B2423	130B2414	28
P3K0		4	100	130B2423	130B2414	28
P4K0		4	100	130B2424	130B2415	45
P5K5		4	100	130B2424	130B2415	45
P7K5		3	100	130B2425	130B2416	75
P11K		3	100	130B2425	130B2416	75
P15K		3	100	130B2426	130B2417	115
P18K		3	100	130B2426	130B2417	115
P22K		3	100	130B2427	130B2418	165
P30K		3	100	130B2427	130B2418	165
P37K	P45K	3	100	130B2425	130B2416	75
P45K	P55K	3	100	130B2425	130B2416	75
P55K	P75K	3	100	130B2426	130B2417	115
P75K	P90K	3	100	130B2426	130B2417	115
P90K	P110	3	100	130B2427	130B2418	165
	P132	2	100	130B2427	130B2418	165
	P160	2	100	130B2428	130B2419	260
	P200	2	100	130B2428	130B2419	260
	P250	2	100	130B2429	130B2420	310
	P315	2	100	130B2238	130B2235	430
	P400	2	100	130B2238	130B2235	430
	P450	2	100	130B2239	130B2236	530
	P500	2	100	130B2239	130B2236	530
	P560	2	100	130B2274	130B2280	630
	P630	2	100	130B2274	130B2280	630
	P710	2	100	130B2430	130B2421	765
	P800	2	100	130B2431	130B2422	1350
	P900	2	100	130B2431	130B2422	1350
	P1M0	2	100	130B2431	130B2422	1350
	P1M2	2	100	130B2431	130B2422	1350
	P1M4	2	100	2x130B2430	2x130B2421	1530

Table 4.14 Mains supply 3x525 to 3x690 V AC

**NOTICE**

 See also *Output Filter Design Guide*.

## 4.2.7 Ordering Numbers: Brake Resistors

**NOTICE**

 See *Brake Resistor Design Guide*.

## 5 Mechanical Installation

### 5.1 Mechanical Installation

#### 5.1.1 Safety Requirements of Mechanical Installation

#### **⚠ WARNING**

Pay attention to the requirements that apply to integration and field mounting kit. Observe the information in the list to avoid serious injury or equipment damage, especially when installing large units.

**5**

#### **CAUTION**

The frequency converter is cooled by means of air circulation.



To protect the unit from overheating, it must be ensured that the ambient temperature *does not exceed the maximum temperature stated for the frequency converter* and that the 24-hour average temperature *is not exceeded*. Locate the maximum temperature and 24-hour average in *chapter 9.6.2 Derating for Ambient Temperature*.

If the ambient temperature is in the range of 45 °C - 55 °C, derating of the frequency converter becomes relevant, see *chapter 9.6.2 Derating for Ambient Temperature*.

The service life of the frequency converter is reduced if derating for ambient temperature is not taken into account.

5.1.2 Mechanical Dimensions

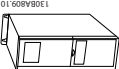
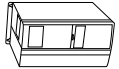
5

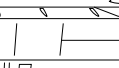
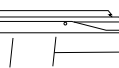
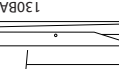
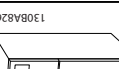
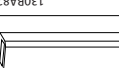
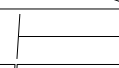
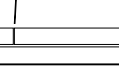
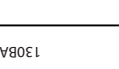
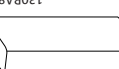
A2		IP20/21	130BA090.10
A3		IP20/21	130BA080.10
A4		IP55/66	130BA58.10
A5		IP55/66	130BA11.10
B1		IP21/55/66	130BA12.10
B2		IP21/55/66	130BA13.10
B3		IP20	130BA26.10
B4		IP20	130BA27.10
C1		IP21/55/66	130BA14.10
C2		IP21/55/66	130BA15.10
C3		IP20	130BA28.10
C4		IP20	130BA29.10

		
---	---	--

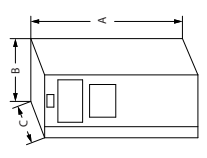
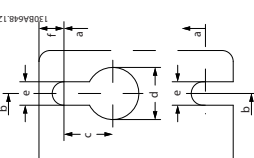
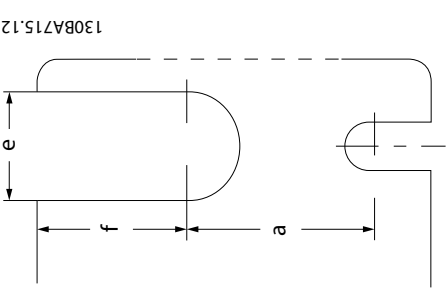
\* A5 in IP55/66 only

Top and bottom mounting holes (B4, C3 and C4 only)

Accessory bags containing necessary brackets, screws and connectors are included with the frequency converters upon delivery.

Table 5.1 Mechanical Dimensions



Enclosure Type	A2	A3	A4	A5	B1	B2	B3	B4	C1	C2	C3	C4
Rated Power [kW]	200-240 V	3-3.7	1.1-2.2	1.1-3.7	5.5-11	15	5.5-11	15-18	18-30	37-45	22-30	37-45
	380-480/500 V	5.5-7.5	1.1-4	1.1-7.5	11-18	22-30	11-18	22-37	37-55	75-90	45-55	75-90
IP	525-600 V	1.1-7.5		1.1-7.5	11-18	22-30	11-18	22-37	37-55	75-90	45-55	75-90
	525-690 V				11-30				37-90			
NEMA	20 Chassis Type 1	20 Chassis Type 1	55/66 Type 12	55/66 Type 12	21/ 55/66 Type 1/Type 12	21/55/66 Type 1/ Type 12	20 Chassis	20 Chassis	21/55/66 Type 1/ Type 12	21/55/66 Type 1/ Type 12	20 Chassis	20 Chassis
Height [mm]												
Height of back plate	A 268	268	390	420	480	650	399	520	680	770	550	660
Height with de-coupling plate for Fieldbus cables	A 374	374	-	-	-	-	420	595			630	800
Distance between mounting holes	a 257	257	401	402	454	624	380	495	648	739	521	631
Width [mm]												
Width of back plate	B 90	130	200	242	242	242	165	230	308	370	308	370
Width of back plate with one C option	B 130	170		242	242	242	205	230	308	370	308	370
Width of back plate with 2 C options	B 150	190		242	242	242	225	230	308	370	308	370
Distance between mounting holes	b 70	110	171	215	210	210	140	200	272	334	270	330
Depth [mm]												
Depth without option A/B	C 205	205	175	200	260	260	249	242	310	335	333	333
With option A/B	C 220	222	175	200	260	260	262	242	310	335	333	333
Screw holes [mm]												
	c 8.0	8.0	8.25	8.25	12	12	8		12.5	12.5		
	d ø11	ø11	ø12	ø12	ø19	ø19	12		ø19	ø19		
	e ø5.5	ø5.5	ø6.5	ø6.5	ø9	ø9	6.8	8.5	ø9	ø9	8.5	8.5
	f 9	9	6	9	9	9	7.9	15	9.8	9.8	17	17
Max weight [kg]	4.9	5.3	9.7	13.5/14.2	23	27	12	23.5	45	65	35	50
Front cover tightening torque [Nm]												
Plastic cover (low IP)	Click	Click	-	-	Click	Click	Click	Click	Click	Click	2.0	2.0
Metal cover (IP55/66)	-	-	1.5	1.5	2.2	2.2	-	-	2.2	2.2	2.0	2.0

Table 5.2 Weight and Dimensions

5.1.3 Accessory Bags

5

				<p>Enclosure type C1 and C2</p> 	<p>Enclosure type B1 and B2</p> 	<p>Enclosure type A5</p> 	<p>Enclosure type A1, A2 and A3</p> 	<p>Enclosure type C4</p>	<p>Enclosure type C3</p>	<p>Enclosure type B4</p>	<p>Enclosure type B3</p>
<p>1 + 2 only available in units with brake chopper. For DC-link connection (Load sharing), connector 1 can be ordered separately (Code no. 130B1064)          An 8-pole connector is included in accessory bag for FC 102 without Safe Torque Off.</p>											

Table 5.3 Parts included in Accessory Bags

### 5.1.4 Mechanical Mounting

All enclosure types allow side-by-side installation except when a IP21/IP4X/TYPE 1 Enclosure Kit is used (see chapter 3.1 Options and Accessories).

#### Side-by-side mounting

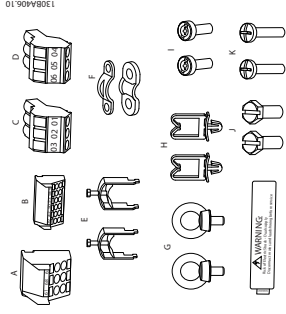
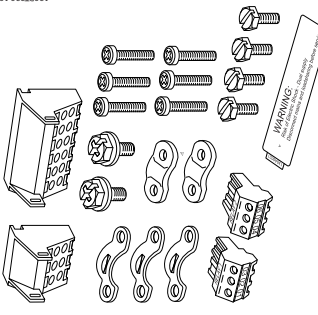
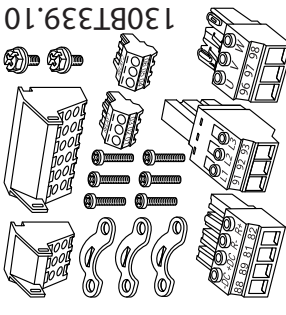
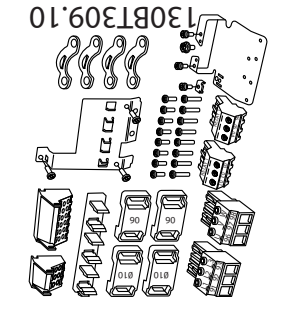
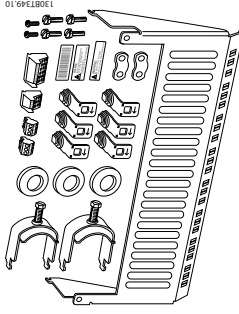
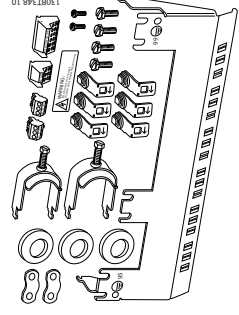
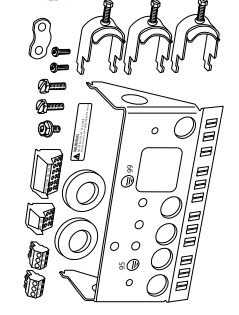
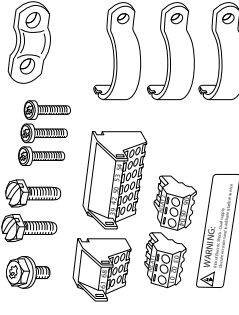
IP20 A and B enclosures can be arranged side-by-side with no clearance required between them, but the mounting order is important. *Illustration 5.1* shows how to mount the frames correctly.

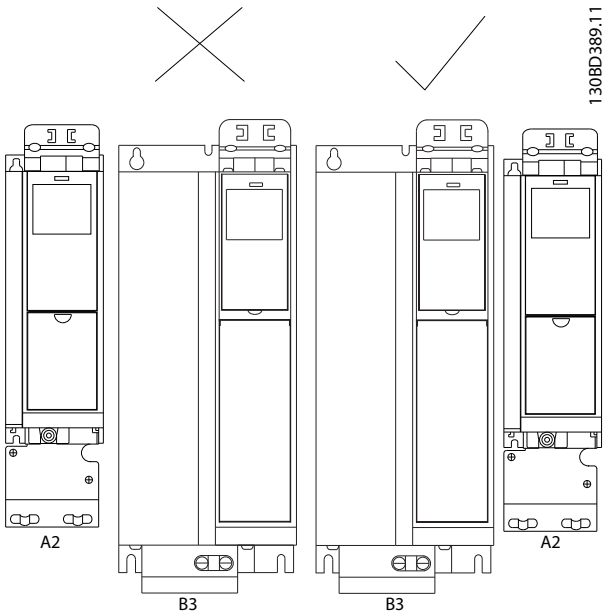

Illustration 5.1 Correct Side-by-side Mounting

If the IP 21 Enclosure kit is used on enclosure type A2 or A3, there must be a clearance between the frequency converters of min. 50 mm.

For optimal cooling conditions, allow a free-air passage above and below the frequency converter. See *Table 5.4*.

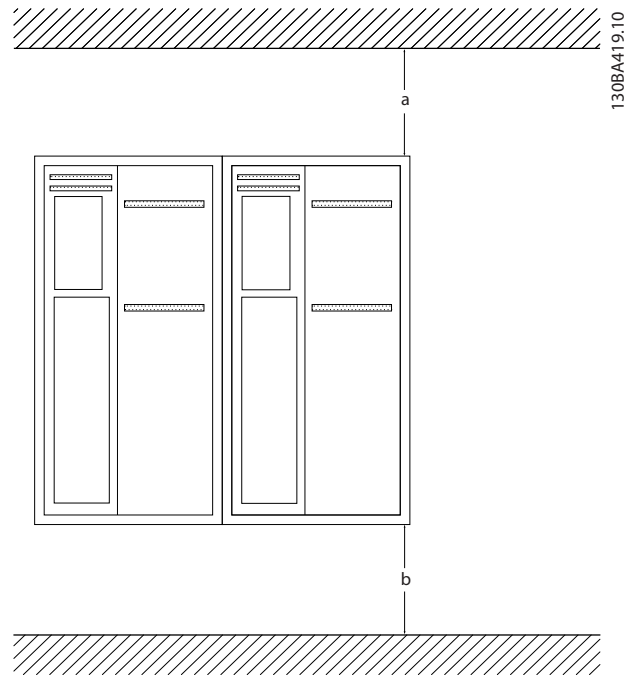

Illustration 5.2 Clearance

Enclosure type	A2/A3/A4/A5/B1	B2/B3/B4/C1/C3	C2/C4
a [mm]	100	200	225
b [mm]	100	200	225

Table 5.4 Air Passage for Different Enclosure Types

1. Drill holes in accordance with the measurements given.
2. Provide screws suitable for the surface for mounting the frequency converter. Retighten all 4 screws.

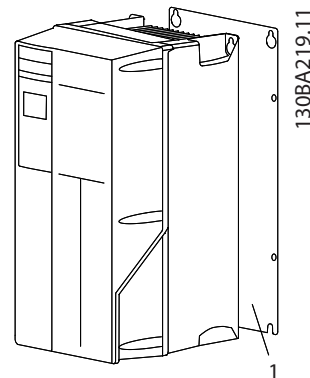

Illustration 5.3 Proper Mounting with Back Plate

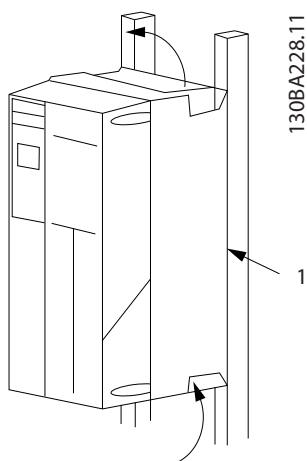

Illustration 5.4 Proper Mounting with Railings

### 5.1.5 Field Mounting

For field mounting the IP21/IP4X top/TYPE 1 kits or IP54/55 units are recommended.

Item	Description
1	Back plate

Table 5.5 Legend to Illustration 5.4

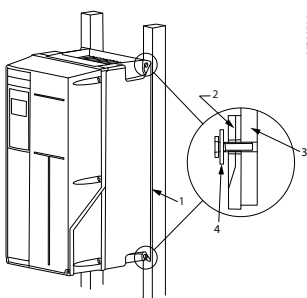

Illustration 5.5 Mounting on a Non-solid Back Wall

Mounting enclosure types A4, A5, B1, B2, C1 and C2 on a non-solid back wall, the frequency converter must be provided with a back plate, "1", due to insufficient cooling air over the heat sink.

Enclosure	IP20	IP21	IP55	IP66
A2	*	*	-	-
A3	*	*	-	-
A4/A5	-	-	2	2
B1	-	*	2.2	2.2
B2	-	*	2.2	2.2
B3	*	-	-	-
B4	2	-	-	-
C1	-	*	2.2	2.2
C2	-	*	2.2	2.2
C3	2	-	-	-
C4	2	-	-	-

\* = No screws to tighten  
 - = Does not exist

Table 5.6 Tightening Torque for Covers (Nm)

## 6 Electrical Installation

### 6.1 Connections - Enclosure Types A, B and C

#### 6.1.1 Torque

#### **NOTICE**

##### Cables General

All cabling must comply with national and local regulations on cable cross-sections and ambient temperature. Copper (75 °C) conductors are recommended.

##### Aluminium Conductors

Terminals can accept aluminium conductors, but the conductor surface has to be clean and the oxidation must be removed and sealed by neutral acid-free Vaseline grease before the conductor is connected.

Furthermore the terminal screw must be retightened after 2 days due to softness of the aluminium. It is crucial to keep the connection a gas tight joint, otherwise the aluminium surface oxidises again.

Enclosure type	200-240 V [kW]	380-480 V [kW]	525-690 V [kW]	Cable for	Tightening up torque [Nm]
A2	1.1-2.2	1.1-4	-		
A3	3-3.7	5.5-7.5	-		
A4	1.1-2.2	1.1-4			
A5	1.1-3.7	1.1-7.5	-		
B1	5.5-11	11-18	-	Mains, Brake resistor, load sharing, Motor cables	1.8
				Relay	0.5-0.6
				Ground	2-3
B2	15	22-30	11-30	Mains, Brake resistor, load sharing cables	4.5
				Motor cables	4.5
				Relay	0.5-0.6
				Ground	2-3
B3	5.5-11	11-18	-	Mains, Brake resistor, load sharing, Motor cables	1.8
				Relay	0.5-0.6
				Ground	2-3
B4	15-18	22-37	-	Mains, Brake resistor, load sharing, Motor cables	4.5
				Relay	0.5-0.6
				Ground	2-3
C1	18-30	37-55	-	Mains, Brake resistor, load sharing cables	10
				Motor cables	10
				Relay	0.5-0.6
				Ground	2-3
C2	37-45	75-90	37-90	Mains, motor cables	14 (up to 9 5mm <sup>2</sup> ) 24 (over 95 mm <sup>2</sup> )
				Load Sharing, brake cables	14
				Relay	0.5-0.6
				Ground	2-3
C3	22-30	45-55	-	Mains, Brake resistor, load sharing, Motor cables	10
				Relay	0.5-0.6
				Ground	2-3
C4	37-45	75-90	-	Mains, motor cables	14 (up to 95 mm <sup>2</sup> ) 24 (over 95 mm <sup>2</sup> )
				Load Sharing, brake cables	14
				Relay	0.5-0.6
				Ground	2-3

Table 6.1 Tightening-up Torque

### 6.1.2 Removal of Knockouts for Extra Cables

1. Remove cable entry from the frequency converter (Avoiding foreign parts falling into the frequency converter when removing knockouts).
2. Cable entry has to be supported around the knockout to be removed.
3. The knockout can now be removed with a strong mandrel and a hammer.
4. Remove burrs from the hole.
5. Mount cable entry on frequency converter.

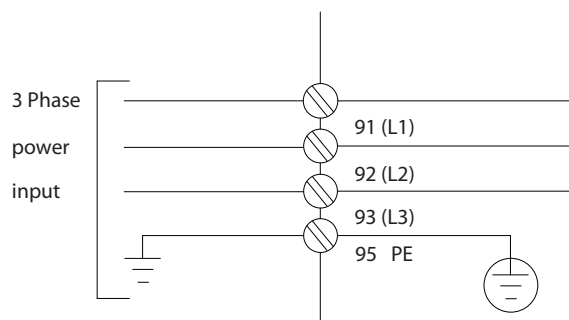

Illustration 6.1 Mains Connection

### Mains connection for enclosure types A1, A2 and A3:

6

### 6.1.3 Connection to Mains and Earthing

**NOTICE**

The plug connector for power is pluggable on frequency converters up to 7.5 kW.

1. Fit the 2 screws in the de-coupling plate, slide it into place and tighten the screws.
2. Make sure the frequency converter is properly grounded. Connect to ground connection (terminal 95). Use screw from the accessory bag.
3. Place plug connector 91 (L1), 92 (L2), 93 (L3) from the accessory bag onto the terminals labelled MAINS at the bottom of the frequency converter.
4. Attach mains wires to the mains plug connector.
5. Support the cable with the supporting enclosed brackets.

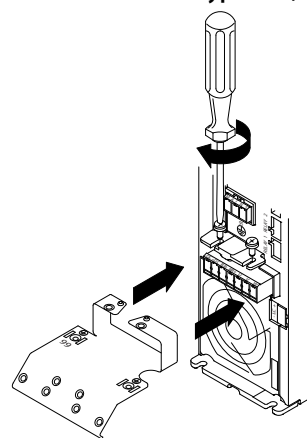

Illustration 6.2 Fitting the Mounting Plate

**NOTICE**

Check that mains voltage corresponds to the mains voltage of the name plate.

**CAUTION**

IT Mains

Do not connect 400 V frequency converters with RFI-filters to mains supplies with a voltage between phase and earth of more than 440 V.

**CAUTION**

The earth connection cable cross section must be at least 10 mm<sup>2</sup> or 2 x rated mains wires terminated separately according to EN 50178.

The mains connection is fitted to the mains switch, if this is included.

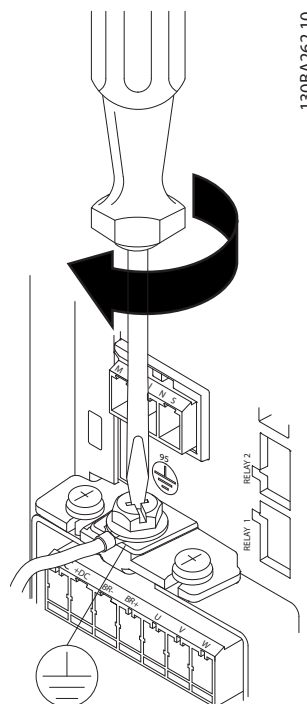

Illustration 6.3 Tightening the Earth Cable

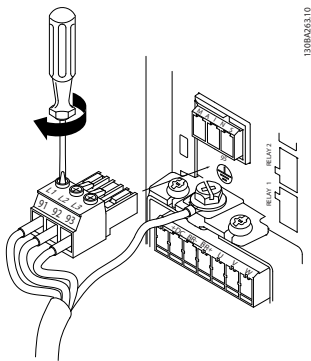

Illustration 6.4 Mounting Mains Plug and Tightening Wires

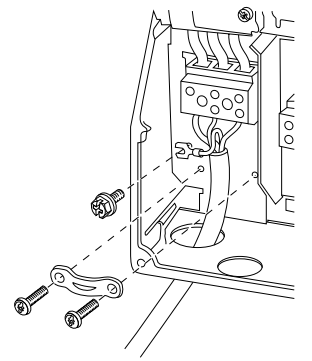

Illustration 6.8 Mains Connection Enclosure Types B1 and B2 (IP21/NEMA Type 1 and IP55/66/ NEMA Type 12)

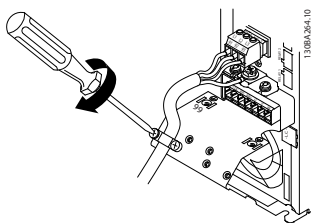

Illustration 6.5 Tighten Support Bracket

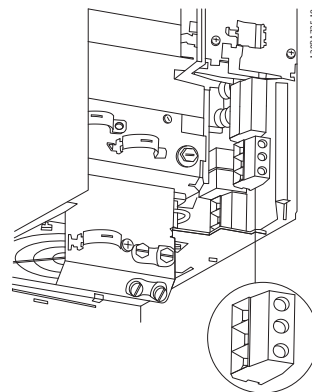

Illustration 6.9 Mains Connection Enclosure Type B3 (IP20)

**Mains connector enclosure type A4/A5 (IP55/66)**

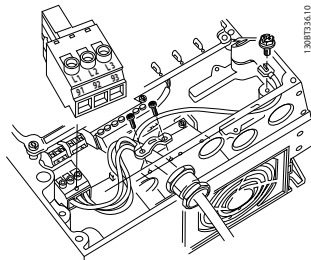

Illustration 6.6 Connecting to Mains and Earthing without Disconnecter

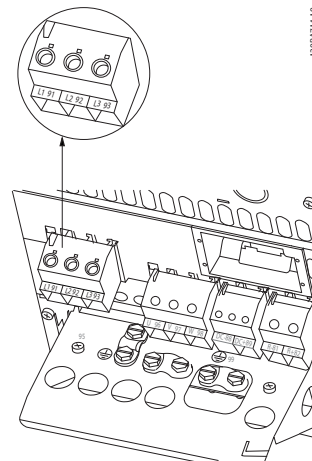

Illustration 6.10 Mains Connection Enclosure Type B4 (IP20)

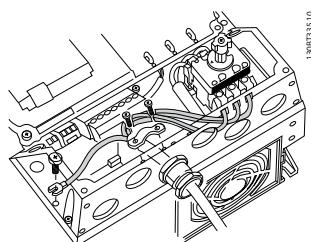

Illustration 6.7 Connecting to Mains and Earthing with Disconnecter

When disconnecter is used (enclosure type A4/A5) the PE must be mounted on the left side of the frequency converter.

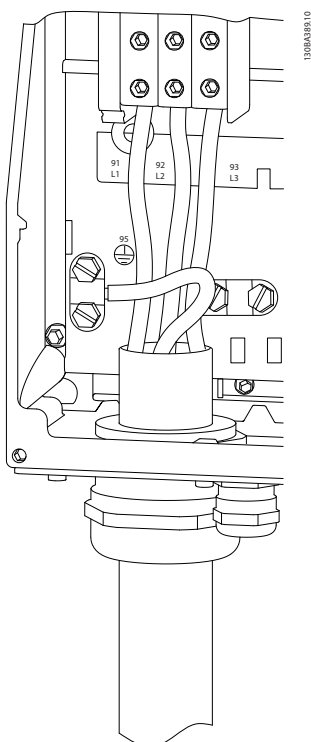

Illustration 6.11 Mains Connection Enclosure Types C1 and C2 (IP21/NEMA Type 1 and IP55/66/NEMA Type 12).

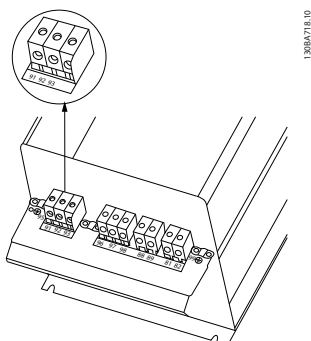

Illustration 6.12 Mains Connection Enclosure Type C3 (IP20).

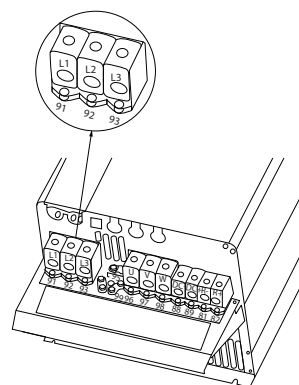

Illustration 6.13 Mains Connection Enclosure Type C4 (IP20).

Usually the power cables for mains are unshielded cables.

### 6.1.4 Motor Connection

#### **NOTICE**

To comply with EMC emission specifications, screened/ armoured cables are required. For more information, see *chapter 2.9.2 EMC Test Results*.

See *chapter 9 General Specifications and Troubleshooting* for correct dimensioning of motor cable cross-section and length.

#### **Screening of cables:**

Avoid installation with twisted screen ends (pigtailed). They spoil the screening effect at higher frequencies. If it is necessary to break the screen to install a motor isolator or motor contactor, the screen must be continued at the lowest possible HF impedance.

Connect the motor cable screen to both the decoupling plate of the frequency converter and to the metal housing of the motor.

Make the screen connections with the largest possible surface area (cable clamp). This is done by using the supplied installation devices in the frequency converter. If it is necessary to split the screen to install a motor isolator or motor relay, continue the screen with the lowest possible HF impedance.



**Cable-length and cross-section**

The frequency converter has been tested with a given length of cable and a given cross-section of that cable. If the cross-section is increased, the cable capacitance - and thus the leakage current - may increase, and the cable length must be reduced correspondingly. Keep the motor cable as short as possible to reduce the noise level and leakage currents.

**Switching frequency**

When frequency converters are used with Sine-wave filters to reduce the acoustic noise from a motor, the switching frequency must be set according to the Sine-wave filter instruction in *14-01 Switching Frequency*.

1. Fasten decoupling plate to the bottom of the frequency converter with screws and washers from the accessory bag.
2. Attach motor cable to terminals 96 (U), 97 (V), 98 (W).
3. Connect to earth connection (terminal 99) on decoupling plate with screws from the accessory bag.
4. Insert plug connectors 96 (U), 97 (V), 98 (W) (up to 7.5 kW) and motor cable to terminals labelled MOTOR.
5. Fasten screened cable to decoupling plate with screws and washers from the accessory bag.

All types of 3-phase asynchronous standard motors can be connected to the frequency converter. Normally, small motors are star-connected (230/400 V, Y). Large motors are normally delta-connected (400/690 V, Δ). Refer to the motor name plate for correct connection mode and voltage.

**Procedure**

1. Strip a section of the outer cable insulation.
2. Position the stripped wire under the cable clamp to establish mechanical fixation and electrical contact between cable screen and ground.
3. Connect ground wire to the nearest grounding terminal in accordance with grounding instructions.
4. Connect the 3-phase motor wiring to terminals 96 (U), 97 (V), and 98 (W), see *Illustration 6.14*.
5. Tighten terminals in accordance with the information provided in *chapter 6.1.1 Torque*.

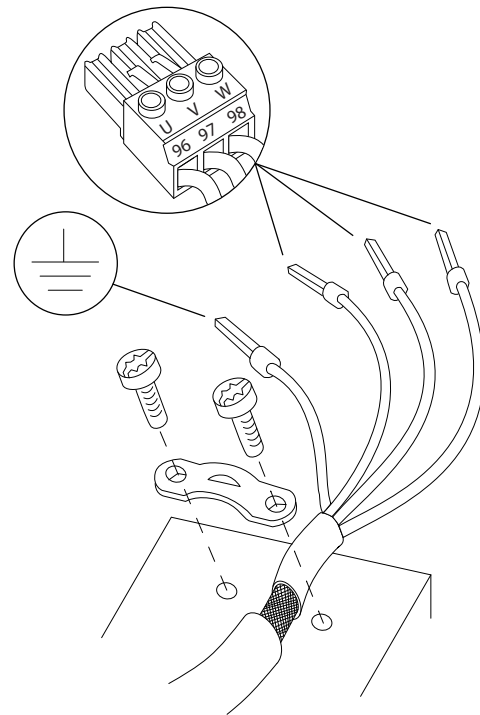

**Illustration 6.14 Motor Connection**

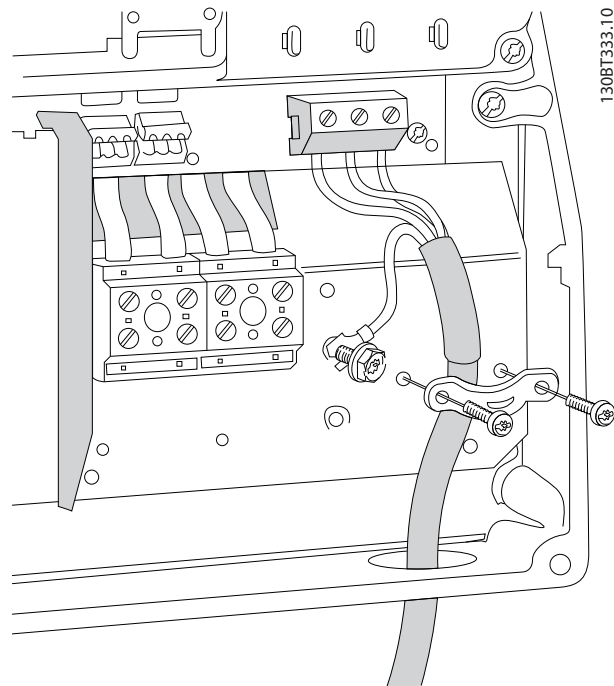

**Illustration 6.15 Motor Connection for Enclosure Type B1 and B2 (IP21/NEMA Type 1, IP55/NEMA Type 12 and IP66/NEMA Type 4X)**

130BD531.10

130BT333.10

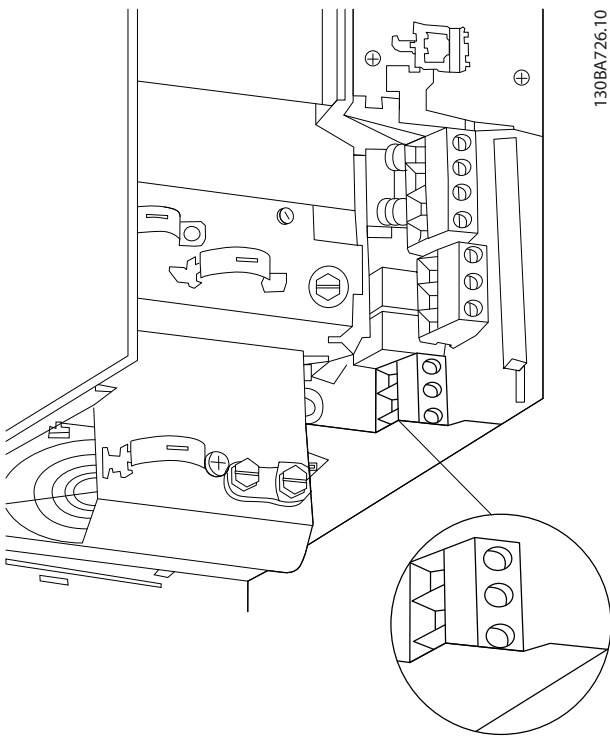

Illustration 6.16 Motor Connection for Enclosure Type B3

130BA726.10

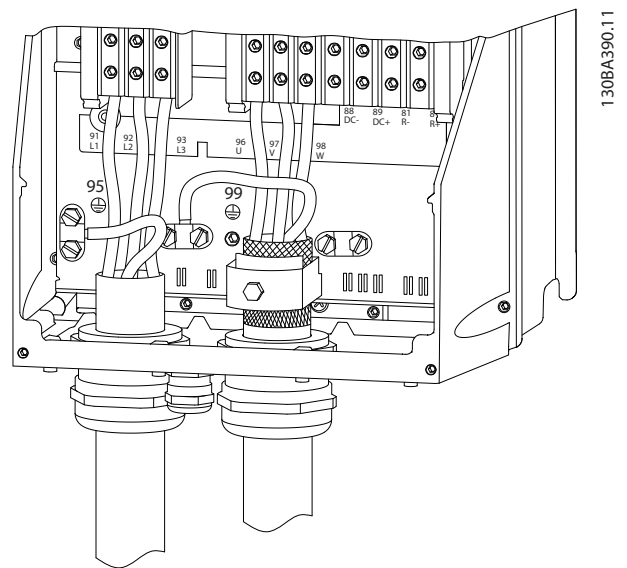

Illustration 6.18 Motor Connection Enclosure Type C1 and C2 (IP21/NEMA Type 1 and IP55/66/NEMA Type 12)

130BA390.11

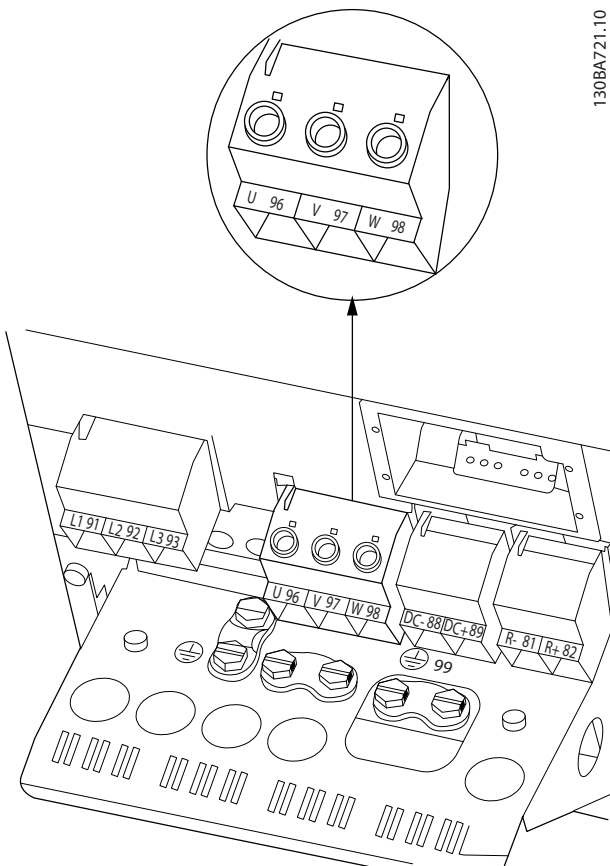

Illustration 6.17 Motor Connection for Enclosure Type B4

130BA721.10

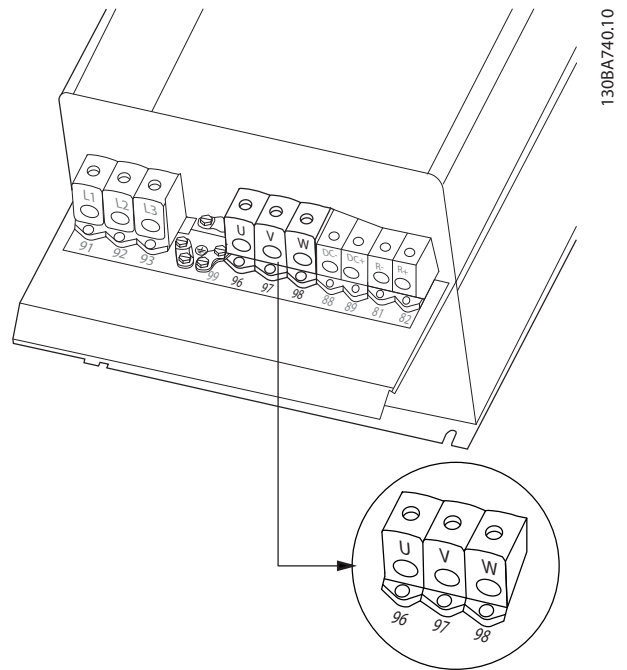

Illustration 6.19 Motor Connection for Enclosure Type C3 and C4

130BA740.10

Term. no.	96	97	98	99	
	U	V	W	PE <sup>1)</sup>	Motor voltage 0-100% of mains voltage. 3 wires out of motor
	U1	V1	W1	PE <sup>1)</sup>	Delta-connected
	W2	U2	V2		6 wires out of motor
	U1	V1	W1	PE <sup>1)</sup>	Star-connected U2, V2, W2 U2, V2 and W2 to be interconnected separately.

Table 6.2 Terminal Descriptions

<sup>1)</sup>Protected Earth Connection

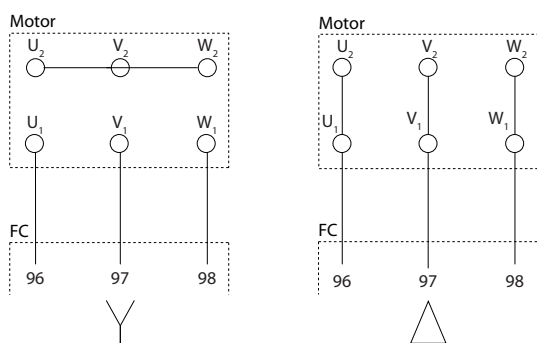

Illustration 6.20 Star and Delta Connections

175ZA114.11

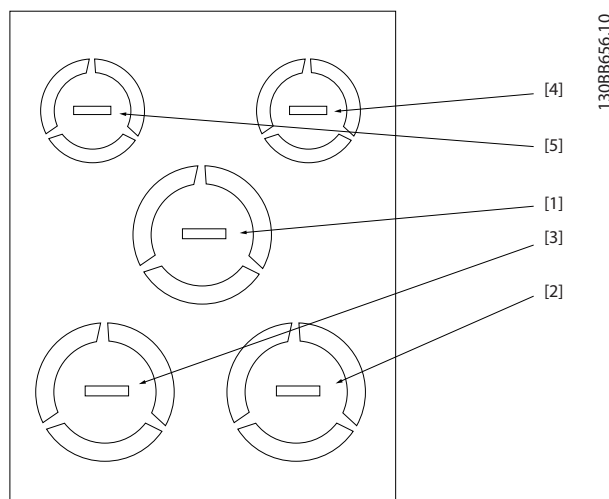

Illustration 6.21 A2 - IP21

Hole Number and recommended use	Dimensions <sup>1)</sup>		Nearest metric
	UL [in]	[mm]	
1) Mains	3/4	28.4	M25
2) Motor	3/4	28.4	M25
3) Brake/Load S	3/4	28.4	M25
4) Control Cable	1/2	22.5	M20
5) Control Cable	1/2	22.5	M20

Table 6.3 Legend to Illustration 6.21

<sup>1)</sup> Tolerance  $\pm 0.2$  mm

**NOTICE**

In motors without phase insulation paper or other insulation reinforcement suitable for operation with voltage supply (such as a frequency converter), fit a Sine-wave filter on the output of the frequency converter.

**Cable entry holes**

The suggested use of the holes are purely recommendations and other solutions are possible. Unused cable entry holes can be sealed with rubber grommets (for IP21).

\* Tolerance  $\pm 0.2$  mm

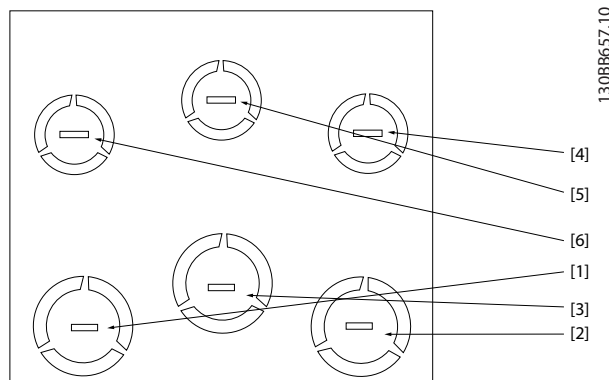

Illustration 6.22 A3 - IP21

Hole Number and recommended use	Dimensions <sup>1)</sup>		Nearest metric
	UL [in]	[mm]	
1) Mains	3/4	28.4	M25
2) Motor	3/4	28.4	M25
3) Brake/Load Sharing	3/4	28.4	M25
4) Control Cable	1/2	22.5	M20
5) Control Cable	1/2	22.5	M20
6) Control Cable	1/2	22.5	M20

Table 6.4 Legend to Illustration 6.22

<sup>1)</sup> Tolerance  $\pm 0.2$  mm

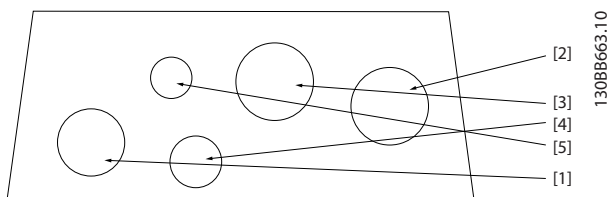

Illustration 6.23 A4 - IP55

Hole Number and recommended use	Dimensions <sup>1)</sup>		Nearest metric
	UL [in]	[mm]	
1) Mains	3/4	28.4	M25
2) Motor	3/4	28.4	M25
3) Brake/Load Sharing	3/4	28.4	M25
4) Control Cable	1/2	22.5	M20
5) Removed	-	-	-

Table 6.5 Legend to Illustration 6.23

<sup>1)</sup> Tolerance  $\pm 0.2$  mm

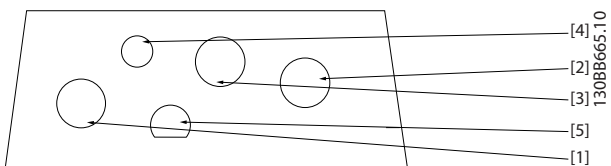

Illustration 6.24 A4 - IP55 Threaded Gland Holes

Hole Number and recommended use	Nearest metric
1) Mains	M25
2) Motor	M25
3) Brake/Load Sharing	M25
4) Control Cable	M16
5) Control Cable	M20

Table 6.6 Legend to Illustration 6.24

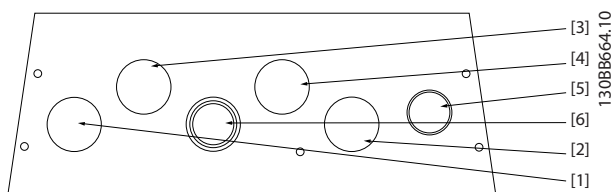

Illustration 6.25 A5 - IP55

Hole Number and recommended use	Dimensions <sup>1)</sup>		Nearest metric
	UL [in]	[mm]	
1) Mains	3/4	28.4	M25
2) Motor	3/4	28.4	M25
3) Brake/Load Sharing	3/4	28.4	M25
4) Control Cable	3/4	28.4	M25
5) Control Cable <sup>2)</sup>	3/4	28.4	M25
6) Control Cable <sup>2)</sup>	3/4	28.4	M25

Table 6.7 Legend to Illustration 6.25

<sup>1)</sup> Tolerance  $\pm 0.2$  mm

<sup>2)</sup> Knock-out hole

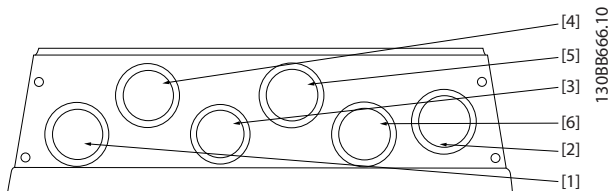

Illustration 6.26 A5- IP55 Threaded Gland Holes

Hole Number and recommended use	Nearest metric
1) Mains	M25
2) Motor	M25
3) Brake/Load S	28.4 mm <sup>1)</sup>
4) Control Cable	M25
5) Control Cable	M25
6) Control Cable	M25

Table 6.8 Legend to Illustration 6.26

<sup>1)</sup> Knock-out hole

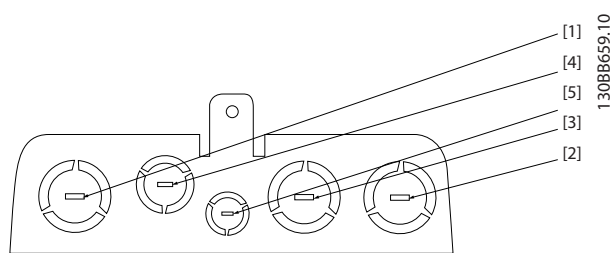

Illustration 6.27 B1 - IP21

Hole Number and recommended use	Dimensions <sup>1)</sup>		Nearest metric
	UL [in]	[mm]	
1) Mains	1	34.7	M32
2) Motor	1	34.7	M32
3) Brake/Load Sharing	1	34.7	M32
4) Control Cable	1	34.7	M32
5) Control Cable	1/2	22.5	M20

Table 6.9 Legend to Illustration 6.27

<sup>1)</sup> Tolerance  $\pm 0.2$  mm

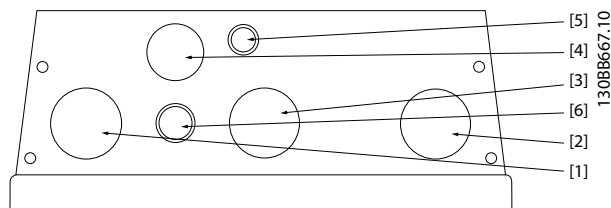

Illustration 6.28 B1 - IP55

Hole Number and recommended use	Dimensions <sup>1)</sup>		Nearest metric
	UL [in]	[mm]	
1) Mains	1	34.7	M32
2) Motor	1	34.7	M32
3) Brake/Load Sharing	1	34.7	M32
4) Control Cable	3/4	28.4	M25
5) Control Cable	1/2	22.5	M20
5) Control Cable <sup>2)</sup>	1/2	22.5	M20

Table 6.10 Legend to Illustration 6.28

<sup>1)</sup> Tolerance  $\pm 0.2$  mm

<sup>2)</sup> Knock-out hole

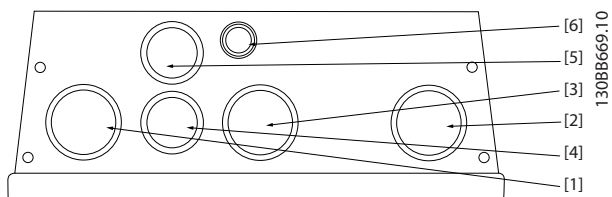

Illustration 6.29 B1 - IP55 Threaded Gland Holes

Hole Number and recommended use	Nearest metric
1) Mains	M32
2) Motor	M32
3) Brake/Load Sharing	M32
4) Control Cable	M25
5) Control Cable	M25
6) Control Cable	22.5 mm <sup>1)</sup>

Table 6.11 Legend to Illustration 6.29

<sup>1)</sup> Knock-out hole

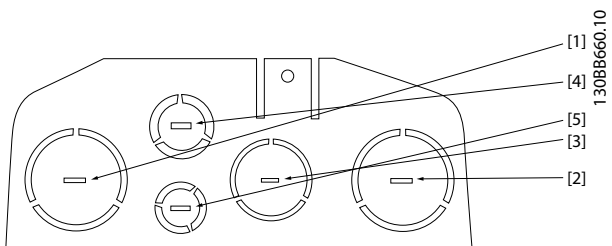

Illustration 6.30 B2 - IP21

Hole Number and recommended use	Dimensions <sup>1)</sup>		Nearest metric
	UL [in]	[mm]	
1) Mains	1 1/4	44.2	M40
2) Motor	1 1/4	44.2	M40
3) Brake/Load Sharing	1	34.7	M32
4) Control Cable	3/4	28.4	M25
5) Control Cable	1/2	22.5	M20

Table 6.12 Legend to Illustration 6.30

<sup>1)</sup> Tolerance  $\pm 0.2$  mm

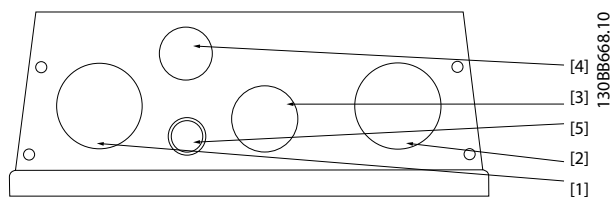

Illustration 6.31 B2 - IP55

Hole Number and recommended use	Dimensions <sup>1)</sup>		Nearest metric
	UL [in]	[mm]	
1) Mains	1 1/4	44.2	M40
2) Motor	1 1/4	44.2	M40
3) Brake/Load Sharing	1	34.7	M32
4) Control Cable	3/4	28.4	M25
5) Control Cable <sup>2)</sup>	1/2	22.5	M20

Table 6.13 Legend to Illustration 6.31

<sup>1)</sup> Tolerance  $\pm 0.2$  mm

<sup>2)</sup> Knock-out hole

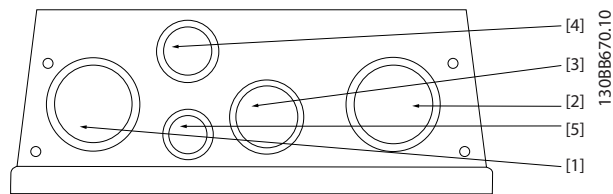

Illustration 6.32 B2 - IP55 Threaded Gland Holes

Hole Number and recommended use	Nearest metric
1) Mains	M40
2) Motor	M40
3) Brake/Load Sharing	M32
4) Control Cable	M25
5) Control Cable	M20

Table 6.14 Legend to Illustration 6.32

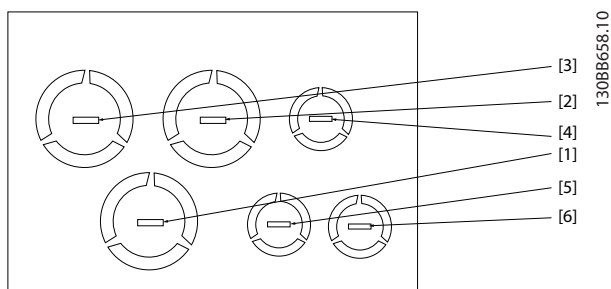

Illustration 6.33 B3 - IP21

Hole Number and recommended use	Dimensions <sup>1)</sup>		Nearest metric
	UL [in]	[mm]	
1) Mains	1	34.7	M32
2) Motor	1	34.7	M32
3) Brake/Load Sharing	1	34.7	M32
4) Control Cable	1/2	22.5	M20
5) Control Cable	1/2	22.5	M20
6) Control Cable	1/2	22.5	M20

Table 6.15 Legend to Illustration 6.33

<sup>1)</sup> Tolerance  $\pm 0.2$  mm

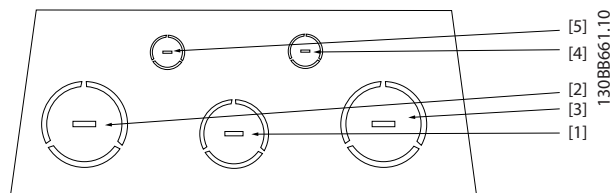

Illustration 6.34 C1 - IP21

Hole Number and recommended use	Dimensions <sup>1)</sup>		Nearest metric
	UL [in]	[mm]	
1) Mains	2	63.3	M63
2) Motor	2	63.3	M63
3) Brake/Load Sharing	1 1/2	50.2	M50
4) Control Cable	3/4	28.4	M25
5) Control Cable	1/2	22.5	M20

Table 6.16 Legend to Illustration 6.34

<sup>1)</sup> Tolerance  $\pm 0.2$  mm

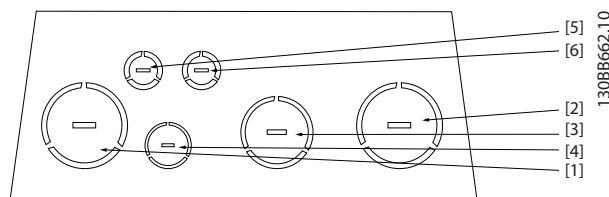

Illustration 6.35 C2 - IP21

Hole Number and recommended use	Dimensions <sup>1)</sup>		Nearest metric
	UL [in]	[mm]	
1) Mains	2	63.3	M63
2) Motor	2	63.3	M63
3) Brake/Load Sharing	1 1/2	50.2	M50
4) Control Cable	3/4	28.4	M25
5) Control Cable	1/2	22.5	M20
6) Control Cable	1/2	22.5	M20

Table 6.17 Legend to Illustration 6.35

<sup>1)</sup> Tolerance  $\pm 0.2$  mm

### 6.1.5 Relay Connection

To set relay output, see parameter group 5-4\* Relays.

No.	01 - 02	make (normally open)
	01 - 03	break (normally closed)
	04 - 05	make (normally open)
	04 - 06	break (normally closed)

Table 6.18 Description of Relays

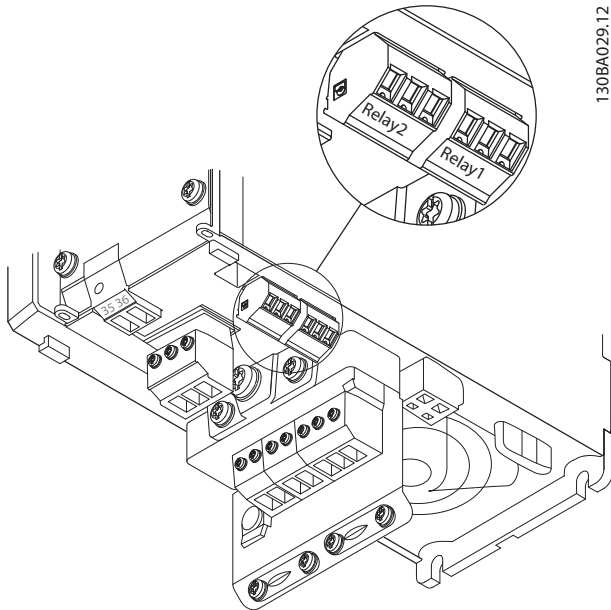

130BA029.12

Illustration 6.36 Terminals for Relay Connection (Enclosure Types A1, A2 and A3).

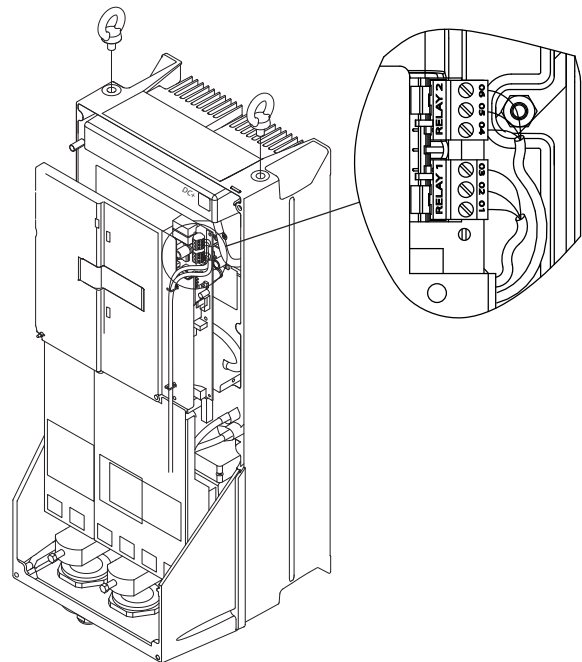

130BA391.12

Illustration 6.37 Terminals for Relay Connection (Enclosure Types C1 and C2).

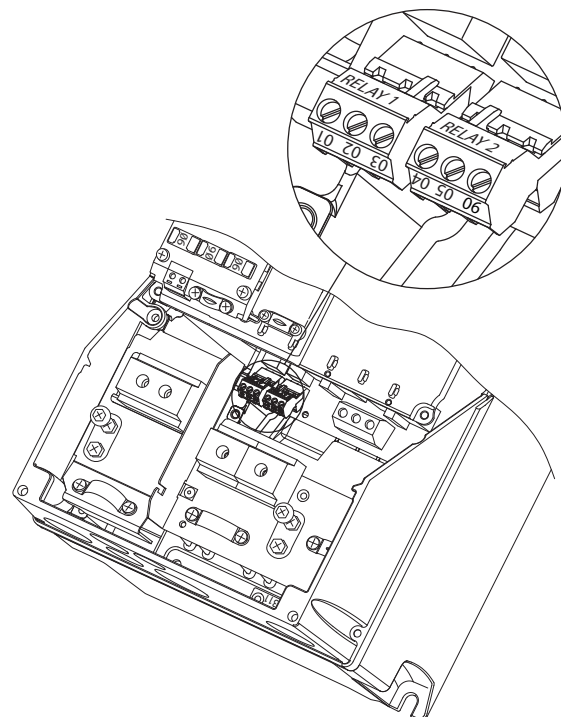

130BA215.10

Illustration 6.38 Terminals for Relay Connection (Enclosure Types A5, B1 and B2).



## 6.2 Fuses and Circuit Breakers

### 6.2.1 Fuses

It is recommended to use fuses and/or circuit breakers on the supply side as protection in case of component break-down inside the frequency converter (first fault).

#### **NOTICE**

Using fuses and/or circuit breakers on the supply side is mandatory to ensure compliance with IEC 60364 for CE or NEC 2009 for UL.

#### **⚠ WARNING**

Protect personnel and property against the consequence of component break-down internally in the frequency converter.

#### **Branch Circuit Protection**

To protect the installation against electrical and fire hazard, all branch circuits in an installation, switch gear, machines etc., must be protected against short-circuit and over-current according to national/international regulations.

#### **NOTICE**

The recommendations given do not cover branch circuit protection for UL.

#### **Short-circuit protection**

Danfoss recommends using the fuses/circuit breakers mentioned below to protect service personnel and property in case of component break-down in the frequency converter.

### 6.2.2 Recommendations

#### **⚠ WARNING**

In case of malfunction, not following the recommendation may result in personnel risk and damage to the frequency converter and other equipment.

The tables in *chapter 6.2.4 Fuse Tables* list the recommended rated current. Recommended fuses are of the type gG for small to medium power sizes. For larger powers, aR fuses are recommended. For circuit breakers, Moeller types are recommended. Other types of circuit breakers may be used, provided they limit the energy into the frequency converter to a level equal to or lower than the Moeller types.

If fuses/circuit breakers according to recommendations are selected, possible damage on the frequency converter is mainly limited to damages inside the unit.

For further information see Application Note *Fuses and Circuit Breakers*.

### 6.2.3 CE Compliance

Fuses or circuit breakers are mandatory to comply with IEC 60364. Danfoss recommend using a selection of the following.

The fuses below are suitable for use on a circuit capable of delivering 100,000 Arms (symmetrical), 240 V, 480 V, 600 V, or 690 V depending on the frequency converter voltage rating. With the proper fusing the frequency converter, short-circuit current rating (SCCR) is 100,000 Arms.

The following UL listed fuses are suitable:

- UL248-4 class CC fuses
- UL248-8 class J fuses
- UL248-12 class R fuses (RK1)
- UL248-15 class T fuses

The following max. fuse size and type have been tested:

## 6.2.4 Fuse Tables

Enclosure type	Power [kW]	Recommended fuse size	Recommended Max. fuse	Recommended circuit breaker Moeller	Max trip level [A]
A2	1.1-2.2	gG-10 (1.1-1.5) gG-16 (2.2)	gG-25	PKZM0-25	25
A3	3.0-3.7	gG-16 (3) gG-20 (3.7)	gG-32	PKZM0-25	25
B3	5.5-11	gG-25 (5.5-7.5) gG-32 (11)	gG-63	PKZM4-50	50
B4	15-18	gG-50 (15) gG-63 (18)	gG-125	NZMB1-A100	100
C3	22-30	gG-80 (22) aR-125 (30)	gG-150 (22) aR-160 (30)	NZMB2-A200	150
C4	37-45	aR-160 (37) aR-200 (45)	aR-200 (37) aR-250 (45)	NZMB2-A250	250
A4	1.1-2.2	gG-10 (1.1-1.5) gG-16 (2.2)	gG-32	PKZM0-25	25
A5	0.25-3.7	gG-10 (0.25-1.5) gG-16 (2.2-3) gG-20 (3.7)	gG-32	PKZM0-25	25
B1	5.5-11	gG-25 (5.5) gG-32 (7.5-11)	gG-80	PKZM4-63	63
B2	15	gG-50	gG-100	NZMB1-A100	100
C1	18-30	gG-63 (18.5) gG-80 (22) gG-100 (30)	gG-160 (18.5-22) aR-160 (30)	NZMB2-A200	160
C2	37-45	aR-160 (37) aR-200 (45)	aR-200 (37) aR-250 (45)	NZMB2-A250	250

Table 6.19 200-240 V, Enclosure Types A, B and C

Enclosure type	Power [kW]	Recommended fuse size	Recommended Max. fuse	Recommended circuit breaker Moeller	Max trip level [A]
A2	1.1-4.0	gG-10 (1.1-3) gG-16 (4)	gG-25	PKZM0-25	25
A3	5.5-7.5	gG-16	gG-32	PKZM0-25	25
B3	11-18	gG-40	gG-63	PKZM4-50	50
B4	22-37	gG-50 (22) gG-63 (30) gG-80 (37)	gG-125	NZMB1-A100	100
C3	45-55	gG-100 (45) gG-160 (55)	gG-150 (45) gG-160 (55)	NZMB2-A200	150
C4	75-90	aR-200 (75) aR-250 (90)	aR-250	NZMB2-A250	250
A4	1.1-4	gG-10 (1.1-3) gG-16 (4)	gG-32	PKZM0-25	25
A5	1.1-7.5	gG-10 (1.1-3) gG-16 (4-7.5)	gG-32	PKZM0-25	25
B1	11-18.5	gG-40	gG-80	PKZM4-63	63
B2	22-30	gG-50 (22) gG-63 (30)	gG-100	NZMB1-A100	100
C1	37-55	gG-80 (37) gG-100 (45) gG-160 (55)	gG-160	NZMB2-A200	160
C2	75-90	aR-200 (75) aR-250 (90)	aR-250	NZMB2-A250	250

6

**Table 6.20 380-480 V, Enclosure Types A, B and C**

Enclosure type	Power [kW]	Recommended fuse size	Recommended Max. fuse	Recommended circuit breaker Moeller	Max trip level [A]
A3	5.5-7.5	gG-10 (5.5) gG-16 (7.5)	gG-32	PKZM0-25	25
B3	11-18	gG-25 (11) gG-32 (15-18)	gG-63	PKZM4-50	50
B4	22-37	gG-40 (22) gG-50 (30) gG-63 (37)	gG-125	NZMB1-A100	100
C3	45-55	gG-63 (45) gG-100 (55)	gG-150	NZMB2-A200	150
C4	75-90	aR-160 (75) aR-200 (90)	aR-250	NZMB2-A250	250
A5	1.1-7.5	gG-10 (1.1-5.5) gG-16 (7.5)	gG-32	PKZM0-25	25
B1	11-18	gG-25 (11) gG-32 (15) gG-40 (18.5)	gG-80	PKZM4-63	63
B2	22-30	gG-50 (22) gG-63 (30)	gG-100	NZMB1-A100	100
C1	37-55	gG-63 (37) gG-100 (45) aR-160 (55)	gG-160 (37-45) aR-250 (55)	NZMB2-A200	160
C2	75-90	aR-200 (75-90)	aR-250	NZMB2-A250	250

**Table 6.21 525-600 V, Enclosure Types A, B and C**

Enclosure type	Power [kW]	Recommended fuse size	Recommended Max. fuse	Recommended circuit breaker Moeller	Max trip level [A]
A3	1.1	gG-6	gG-25	-	-
	1.5	gG-6	gG-25		
	2.2	gG-6	gG-25		
	3	gG-10	gG-25		
	4	gG-10	gG-25		
	5.5	gG-16	gG-25		
	7.5	gG-16	gG-25		
B2	11	gG-25 (11)	gG-63	-	-
	15	gG-32 (15)	gG-80 (30)		
	18	gG-32 (18)			
	22	gG-40 (22)			
	30	gG-63 (30)			
C2	37	gG-63 (37)	gG-100 (37)	-	-
	45	gG-80 (45)	gG-125 (45)		
	55	gG-100 (55)	gG-160 (55-75)		
	75	gG-125 (75)			
C3	45	gG-80	gG-100	-	-
	55	gG-100	gG-125		

Table 6.22 525-690 V, Enclosure Types A, B and C

**UL Compliance**

Fuses or circuit breakers are mandatory to comply with NEC 2009. Danfoss recommends using a selection of the following

The fuses below are suitable for use on a circuit capable of delivering 100,000 Arms (symmetrical), 240 V, or 480 V, or 500 V, or 600 V depending on the frequency converter voltage rating. With the proper fusing the frequency converter Short Circuit Current Rating (SCCR) is 100,000 Arms.

Power [kW]	Recommended max. fuse					
	Bussmann Type RK1 <sup>1)</sup>	Bussmann Type J	Bussmann Type T	Bussmann Type CC	Bussmann Type CC	Bussmann Type CC
1.1	KTN-R-10	JKS-10	JJN-10	FNQ-R-10	KTK-R-10	LP-CC-10
1.5	KTN-R-15	JKS-15	JJN-15	FNQ-R-15	KTK-R-15	LP-CC-15
2.2	KTN-R-20	JKS-20	JJN-20	FNQ-R-20	KTK-R-20	LP-CC-20
3.0	KTN-R-25	JKS-25	JJN-25	FNQ-R-25	KTK-R-25	LP-CC-25
3.7	KTN-R-30	JKS-30	JJN-30	FNQ-R-30	KTK-R-30	LP-CC-30
5.5-7.5	KTN-R-50	KS-50	JJN-50	-	-	-
11	KTN-R-60	JKS-60	JJN-60	-	-	-
15	KTN-R-80	JKS-80	JJN-80	-	-	-
18.5-22	KTN-R-125	JKS-125	JJN-125	-	-	-
30	KTN-R-150	JKS-150	JJN-150	-	-	-
37	KTN-R-200	JKS-200	JJN-200	-	-	-
45	KTN-R-250	JKS-250	JJN-250	-	-	-

Table 6.23 200-240 V, Enclosure Types A, B and C

Power [kW]	Recommended max. fuse			
	SIBA Type RK1	Littel fuse Type RK1	Ferraz-Shawmut Type CC	Ferraz-Shawmut Type RK1 <sup>3)</sup>
1.1	5017906-010	KLN-R-10	ATM-R-10	A2K-10-R
1.5	5017906-016	KLN-R-15	ATM-R-15	A2K-15-R
2.2	5017906-020	KLN-R-20	ATM-R-20	A2K-20-R
3.0	5017906-025	KLN-R-25	ATM-R-25	A2K-25-R
3.7	5012406-032	KLN-R-30	ATM-R-30	A2K-30-R
5.5-7.5	5014006-050	KLN-R-50	-	A2K-50-R
11	5014006-063	KLN-R-60	-	A2K-60-R
15	5014006-080	KLN-R-80	-	A2K-80-R
18.5-22	2028220-125	KLN-R-125	-	A2K-125-R
30	2028220-150	KLN-R-150	-	A2K-150-R
37	2028220-200	KLN-R-200	-	A2K-200-R
45	2028220-250	KLN-R-250	-	A2K-250-R

Table 6.24 200-240 V, Enclosure Types A, B and C

Power [kW]	Recommended max. fuse			
	Bussmann Type JFHR2 <sup>2)</sup>	Littel fuse JFHR2	Ferraz-Shawmut JFHR2 <sup>4)</sup>	Ferraz-Shawmut J
1.1	FWX-10	-	-	HSJ-10
1.5	FWX-15	-	-	HSJ-15
2.2	FWX-20	-	-	HSJ-20
3.0	FWX-25	-	-	HSJ-25
3.7	FWX-30	-	-	HSJ-30
5.5-7.5	FWX-50	-	-	HSJ-50
11	FWX-60	-	-	HSJ-60
15-18.5	FWX-80	-	-	HSJ-80
22	FWX-125	-	-	HSJ-125
30	FWX-150	L25S-150	A25X-150	HSJ-150
37	FWX-200	L25S-200	A25X-200	HSJ-200
45	FWX-250	L25S-250	A25X-250	HSJ-250

Table 6.25 200-240 V, Enclosure Types A, B and C

- 1) KTS-fuses from Bussmann may substitute KTN for 240 V frequency converters.
- 2) FWH-fuses from Bussmann may substitute FWX for 240 V frequency converters.
- 3) A6KR fuses from FERRAZ SHAWMUT may substitute A2KR for 240 V frequency converters.
- 4) A50X fuses from FERRAZ SHAWMUT may substitute A25X for 240 V frequency converters.

Power [kW]	Recommended max. fuse					
	Bussmann Type RK1	Bussmann Type J	Bussmann Type T	Bussmann Type CC	Bussmann Type CC	Bussmann Type CC
1.1	KTS-R-6	JKS-6	JJS-6	FNQ-R-6	KTK-R-6	LP-CC-6
1.5-2.2	KTS-R-10	JKS-10	JJS-10	FNQ-R-10	KTK-R-10	LP-CC-10
3	KTS-R-15	JKS-15	JJS-15	FNQ-R-15	KTK-R-15	LP-CC-15
4	KTS-R-20	JKS-20	JJS-20	FNQ-R-20	KTK-R-20	LP-CC-20
5.5	KTS-R-25	JKS-25	JJS-25	FNQ-R-25	KTK-R-25	LP-CC-25
7.5	KTS-R-30	JKS-30	JJS-30	FNQ-R-30	KTK-R-30	LP-CC-30
11-15	KTS-R-40	JKS-40	JJS-40	-	-	-
18	KTS-R-50	JKS-50	JJS-50	-	-	-
22	KTS-R-60	JKS-60	JJS-60	-	-	-
30	KTS-R-80	JKS-80	JJS-80	-	-	-
37	KTS-R-100	JKS-100	JJS-100	-	-	-
45	KTS-R-125	JKS-125	JJS-125	-	-	-
55	KTS-R-150	JKS-150	JJS-150	-	-	-
75	KTS-R-200	JKS-200	JJS-200	-	-	-
90	KTS-R-250	JKS-250	JJS-250	-	-	-

Table 6.26 380-480 V, Enclosure Types A, B and C

Power [kW]	Recommended max. fuse			
	SIBA Type RK1	Littel fuse Type RK1	Ferraz-Shawmut Type CC	Ferraz-Shawmut Type RK1
1.1-2.2	5017906-010	KLS-R-10	ATM-R-10	A6K-10-R
3	5017906-016	KLS-R-15	ATM-R-15	A6K-15-R
4	5017906-020	KLS-R-20	ATM-R-20	A6K-20-R
5.5	5017906-025	KLS-R-25	ATM-R-25	A6K-25-R
7.5	5012406-032	KLS-R-30	ATM-R-30	A6K-30-R
11-15	5014006-040	KLS-R-40	-	A6K-40-R
18	5014006-050	KLS-R-50	-	A6K-50-R
22	5014006-063	KLS-R-60	-	A6K-60-R
30	2028220-100	KLS-R-80	-	A6K-80-R
37	2028220-125	KLS-R-100	-	A6K-100-R
45	2028220-125	KLS-R-125	-	A6K-125-R
55	2028220-160	KLS-R-150	-	A6K-150-R
75	2028220-200	KLS-R-200	-	A6K-200-R
90	2028220-250	KLS-R-250	-	A6K-250-R

Table 6.27 380-500 V, Enclosure Types A, B and C

Power [kW]	Recommended max. fuse			
	Bussmann JFHR2	Ferraz-Shawmut J	Ferraz-Shawmut JFHR2 <sup>1)</sup>	Littel fuse JFHR2
1.1-2.2	FWH-10	HSJ-10	-	-
3	FWH-15	HSJ-15	-	-
4	FWH-20	HSJ-20	-	-
5.5	FWH-25	HSJ-25	-	-
7.5	FWH-30	HSJ-30	-	-
11-15	FWH-40	HSJ-40	-	-
18	FWH-50	HSJ-50	-	-
22	FWH-60	HSJ-60	-	-
30	FWH-80	HSJ-80	-	-
37	FWH-100	HSJ-100	-	-
45	FWH-125	HSJ-125	-	-
55	FWH-150	HSJ-150	-	-
75	FWH-200	HSJ-200	A50-P-225	L50-S-225
90	FWH-250	HSJ-250	A50-P-250	L50-S-250

Table 6.28 380-480 V, Enclosure Types A, B and C

<sup>1)</sup> Ferraz-Shawmut A50QS fuses may substitute for A50P fuses.

Power [kW]	Recommended max. fuse					Bussmann Type CC
	Bussmann Type RK1	Bussmann Type J	Bussmann Type T	Bussmann Type CC	Bussmann Type CC	
1.1	KTS-R-5	JKS-5	JJS-6	FNQ-R-5	KTK-R-5	LP-CC-5
1.5-2.2	KTS-R-10	JKS-10	JJS-10	FNQ-R-10	KTK-R-10	LP-CC-10
3	KTS-R-15	JKS-15	JJS-15	FNQ-R-15	KTK-R-15	LP-CC-15
4	KTS-R-20	JKS-20	JJS-20	FNQ-R-20	KTK-R-20	LP-CC-20
5.5	KTS-R-25	JKS-25	JJS-25	FNQ-R-25	KTK-R-25	LP-CC-25
7.5	KTS-R-30	JKS-30	JJS-30	FNQ-R-30	KTK-R-30	LP-CC-30
11-15	KTS-R-35	JKS-35	JJS-35	-	-	-
18	KTS-R-45	JKS-45	JJS-45	-	-	-
22	KTS-R-50	JKS-50	JJS-50	-	-	-
30	KTS-R-60	JKS-60	JJS-60	-	-	-
37	KTS-R-80	JKS-80	JJS-80	-	-	-
45	KTS-R-100	JKS-100	JJS-100	-	-	-
55	KTS-R-125	JKS-125	JJS-125	-	-	-
75	KTS-R-150	JKS-150	JJS-150	-	-	-
90	KTS-R-175	JKS-175	JJS-175	-	-	-

Table 6.29 525-600 V, Enclosure Types A, B and C

Power [kW]	Recommended max. fuse			
	SIBA Type RK1	Littell fuse Type RK1	Ferraz-Shawmut Type RK1	Ferraz-Shawmut J
1.1	5017906-005	KLS-R-005	A6K-5-R	HSJ-6
1.5-2.2	5017906-010	KLS-R-010	A6K-10-R	HSJ-10
3	5017906-016	KLS-R-015	A6K-15-R	HSJ-15
4	5017906-020	KLS-R-020	A6K-20-R	HSJ-20
5.5	5017906-025	KLS-R-025	A6K-25-R	HSJ-25
7.5	5017906-030	KLS-R-030	A6K-30-R	HSJ-30
11-15	5014006-040	KLS-R-035	A6K-35-R	HSJ-35
18	5014006-050	KLS-R-045	A6K-45-R	HSJ-45
22	5014006-050	KLS-R-050	A6K-50-R	HSJ-50
30	5014006-063	KLS-R-060	A6K-60-R	HSJ-60
37	5014006-080	KLS-R-075	A6K-80-R	HSJ-80
45	5014006-100	KLS-R-100	A6K-100-R	HSJ-100
55	2028220-125	KLS-R-125	A6K-125-R	HSJ-125
75	2028220-150	KLS-R-150	A6K-150-R	HSJ-150
90	2028220-200	KLS-R-175	A6K-175-R	HSJ-175

Table 6.30 525-600 V, Enclosure Types A, B and C

<sup>1)</sup> 170M fuses shown from Bussmann use the -/80 visual indicator. -TN/80 Type T, -/110 or TN/110 Type T indicator fuses of the same size and amperage may be substituted.



Power [kW]	Recommended max. fuse					
	Bussmann Type RK1	Bussmann Type J	Bussmann Type T	Bussmann Type CC	Bussmann Type CC	Bussmann Type CC
[kW]						
1.1	KTS-R-5	JKS-5	JJS-6	FNQ-R-5	KTK-R-5	LP-CC-5
1.5-2.2	KTS-R-10	JKS-10	JJS-10	FNQ-R-10	KTK-R-10	LP-CC-10
3	KTS-R-15	JKS-15	JJS-15	FNQ-R-15	KTK-R-15	LP-CC-15
4	KTS-R-20	JKS-20	JJS-20	FNQ-R-20	KTK-R-20	LP-CC-20
5.5	KTS-R-25	JKS-25	JJS-25	FNQ-R-25	KTK-R-25	LP-CC-25
7.5	KTS-R-30	JKS-30	JJS-30	FNQ-R-30	KTK-R-30	LP-CC-30
11-15	KTS-R-35	JKS-35	JJS-35	-	-	-
18	KTS-R-45	JKS-45	JJS-45	-	-	-
22	KTS-R-50	JKS-50	JJS-50	-	-	-
30	KTS-R-60	JKS-60	JJS-60	-	-	-
37	KTS-R-80	JKS-80	JJS-80	-	-	-
45	KTS-R-100	JKS-100	JJS-100	-	-	-
55	KTS-R-125	JKS-125	JJS-125	-	-	-
75	KTS-R-150	JKS-150	JJS-150	-	-	-
90	KTS-R-175	JKS-175	JJS-175	-	-	-

**6**

Table 6.31 525-690 V, Enclosure Types A, B and C

Power [kW]	Max. prefuse	Recommended max. fuse						
		Bussmann E52273 RK1/JDDZ	Bussmann E4273 J/JDDZ	Bussmann E4273 T/JDDZ	SIBA E180276 RK1/JDDZ	Littelfuse E81895 RK1/JDDZ	Ferraz-Shawmut E163267/E2137 RK1/JDDZ	Ferraz-Shawmut E2137 J/HSJ
11-15	30 A	KTS-R-30	JKS-30	JKJS-30	5017906-030	KLS-R-030	A6K-30-R	HST-30
18.5	45 A	KTS-R-45	JKS-45	JJS-45	5014006-050	KLS-R-045	A6K-45-R	HST-45
30	60 A	KTS-R-60	JKS-60	JJS-60	5014006-063	KLS-R-060	A6K-60-R	HST-60
37	80 A	KTS-R-80	JKS-80	JJS-80	5014006-080	KLS-R-075	A6K-80-R	HST-80
45	90 A	KTS-R-90	JKS-90	JJS-90	5014006-100	KLS-R-090	A6K-90-R	HST-90
55	100 A	KTS-R-100	JKS-100	JJS-100	5014006-100	KLS-R-100	A6K-100-R	HST-100
75	125 A	KTS-R-125	JKS-125	JJS-125	2028220-125	KLS-150	A6K-125-R	HST-125
90	150 A	KTS-R-150	JKS-150	JJS-150	2028220-150	KLS-175	A6K-150-R	HST-150

Table 6.32 \*525-690 V, Enclosure Types B and C

\* UL compliance only 525-600 V

### 6.3 Disconnectors and Contactors

#### 6.3.1 Mains Disconnectors

Assembling of IP55/NEMA Type 12 (enclosure type A5) with mains disconnector

Mains switch is placed on left side on enclosure types B1, B2, C1 and C2. Mains switch on A5 enclosures is placed on right side

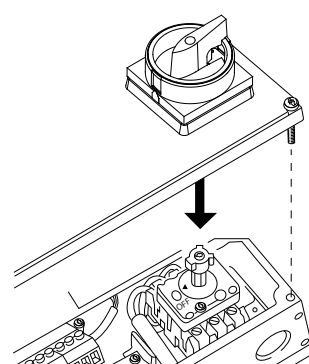

Illustration 6.39 Location of Mains Switch

Enclosure type	Type	Terminal connections
A5	Kraus&Naimer KG20A T303	L1 L2 L3 31 43 T1 T2 T3 32 44 130BB182.10
B1	Kraus&Naimer KG64 T303	L1 L2 L3 13 T1 T2 T3 14 130BB181.10
B2	Kraus&Naimer KG64 T303	
C1 37 kW	Kraus&Naimer KG100 T303	L1 L2 L3 13 T1 T2 T3 14 130BB181.10
C1 45-55 kW	Kraus&Naimer KG105 T303	
C2 75 kW	Kraus&Naimer KG160 T303	
C2 90 kW	Kraus&Naimer KG250 T303	

Table 6.33 Terminal Connections for Various Enclosure Types

### 6.4 Additional Motor Information

#### 6.4.1 Motor Cable

The motor must be connected to terminals U/T1/96, V/T2/97, W/T3/98. Ground to terminal 99. All types of 3-phase asynchronous standard motors can be used with a frequency converter unit. The factory setting is for clockwise rotation with the frequency converter output connected as follows:

Terminal No.	Function
96, 97, 98, 99	Mains U/T1, V/T2, W/T3 Ground

Table 6.34 Terminal Functions

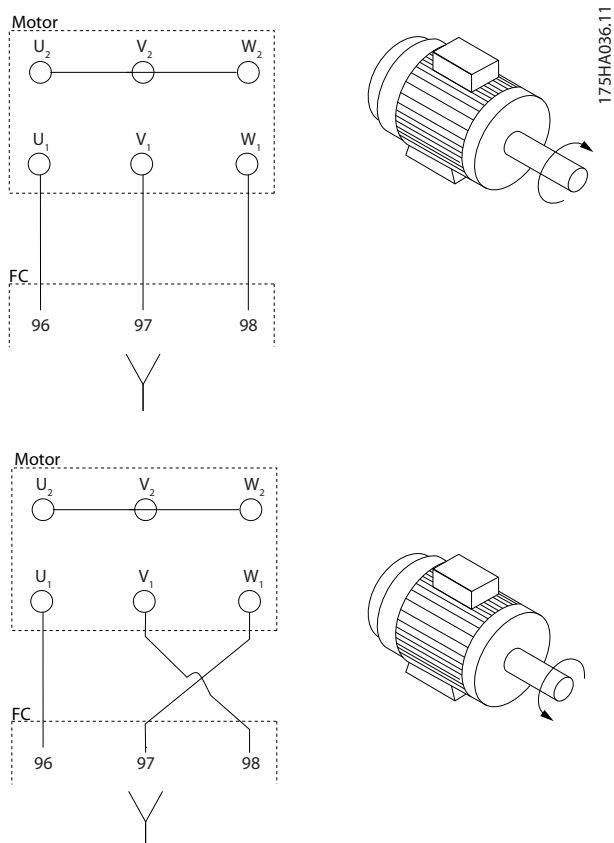

**Illustration 6.40** Terminal Connection for Clockwise and Counter-clockwise Rotation

- Terminal U/T1/96 connected to U-phase
- Terminal V/T2/97 connected to V-phase
- Terminal W/T3/98 connected to W-phase

The direction of rotation can be changed by switching 2 phases in the motor cable or by changing the setting of 4-10 *Motor Speed Direction*.

Motor rotation check can be performed using 1-28 *Motor Rotation Check* and following the steps shown in the display.

### NOTICE

If a retrofit applications requires unequal amount of wires per phase, consult the factory for requirements and documentation or use the top/bottom entry side cabinet option.

## 6.4.2 Motor Thermal Protection

The electronic thermal relay in the frequency converter has received UL-approval for single motor protection, when 1-90 *Motor Thermal Protection* is set for *ETR Trip* and 1-24 *Motor Current* is set to the rated motor current (see the motor name plate).

For thermal motor protection it is also possible to use the PTC Thermistor Card option MCB 112. This card provides ATEX certificate to protect motors in explosion hazardous areas, Zone 1/21 and Zone 2/22. When 1-90 *Motor Thermal Protection* is set to [20] ATEX ETR is combined with the use of MCB 112, it is possible to control an Ex-e motor in explosion hazardous areas. Consult the *Programming Guide* for details on how to set up the frequency converter for safe operation of Ex-e motors.

## 6.4.3 Parallel Connection of Motors

The frequency converter can control several parallel-connected motors. When using parallel motor connection following must be observed:

- Recommended to run applications with parallel motors in U/F mode 1-01 *Motor Control Principle*. Set the U/F graph in 1-55 *U/f Characteristic - U* and 1-56 *U/f Characteristic - F*.
- VCC<sup>plus</sup> mode may be used in some applications.
- The total current consumption of the motors must not exceed the rated output current  $I_{INV}$  for the frequency converter.
- If motor sizes are widely different in winding resistance, starting problems may arise due to too low motor voltage at low speed.
- The electronic thermal relay (ETR) of the frequency inverter cannot be used as motor protection for the individual motor. Provide further motor protection by e.g. thermistors in each motor winding or individual thermal relays. (Circuit breakers are not suitable as protection device).

**NOTICE**

Installations with cables connected in a common joint as shown in the first example in the picture is only recommended for short cable lengths.

**NOTICE**

When motors are connected in parallel, 1-02 Flux Motor Feedback Source cannot be used, and 1-01 Motor Control Principle must be set to Special motor characteristics (U/f).

6

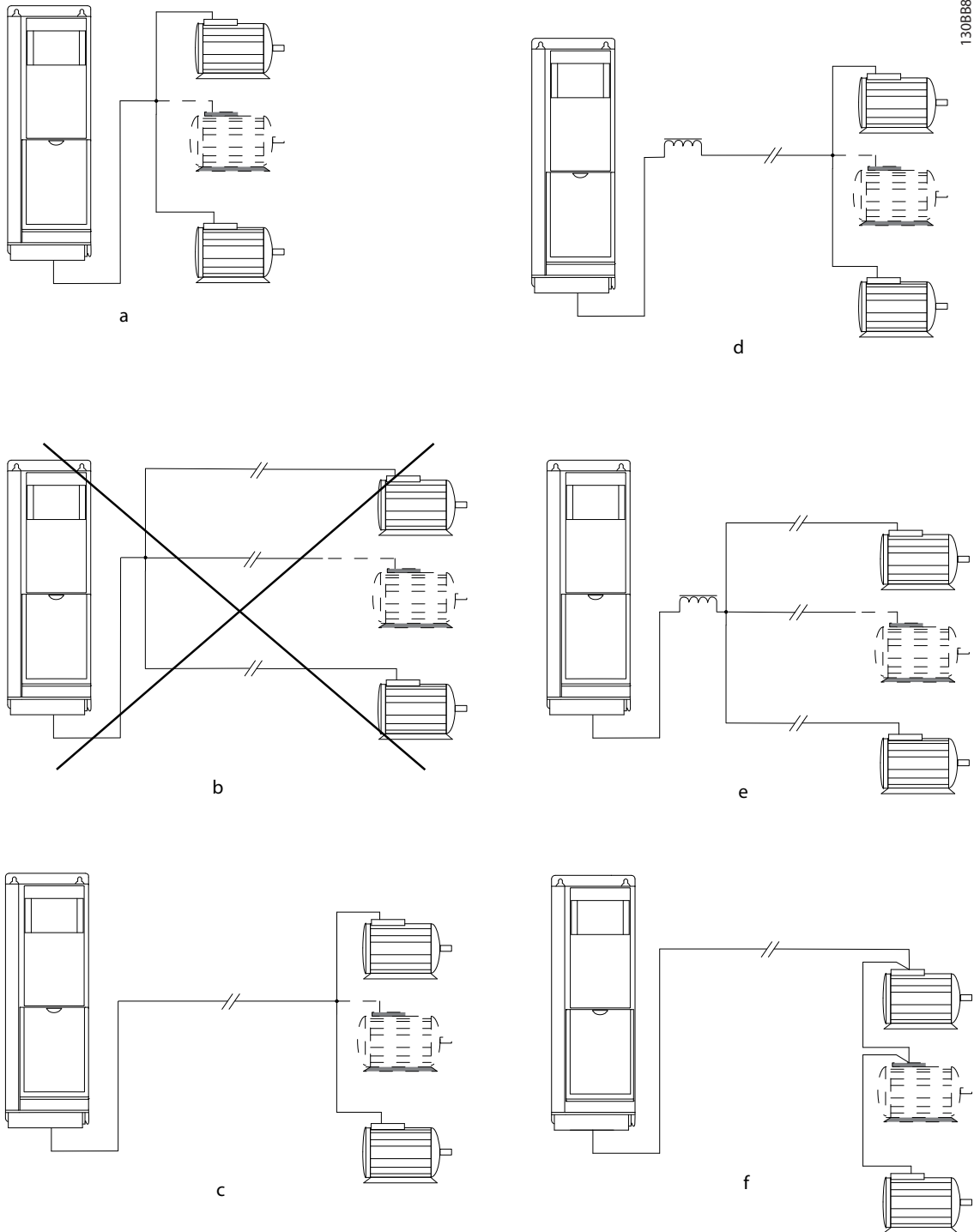

Illustration 6.41 Parallel Motor Connection

- c, d) The total motor cable length specified in section 4.5, *General Specifications*, is valid as long as the parallel cables are kept short (less than 10 m each).
- d, e) Consider voltage drop across the motor cables.
- e) Be aware of the maximum motor cable length specified in *Table 6.35*.
- e) Use LC filter for long parallel cables.

Enclosure Type	Power Size [kW]	Voltage [V]	1 cable [m]	2 cables [m]	3 cables [m]	4 cables [m]
A5	5	400	150	45	8	6
		500	150	7	4	3
A2, A5	1.1-1.5	400	150	45	20	8
		500	150	45	5	4
A2, A5	2.2-4	400	150	45	20	11
		500	150	45	20	6
A3, A5	5.5-7.5	400	150	45	20	11
		500	150	45	20	11
B1, B2, B3, B4, C1, C2, C3, C4	11-90	400	150	75	50	37
		500	150	75	50	37

**Table 6.35 Max. Cable Length for Each Parallel Cable, Depending on Quantity of Parallel Cables.**

Problems may arise at start and at low RPM values, if motor sizes are widely different because small motors' relatively high ohmic resistance in the stator calls for a higher voltage at start and at low RPM values.

The electronic thermal relay (ETR) of the frequency converter cannot be used as motor protection for the individual motor of systems with parallel-connected motors. Provide further motor protection by e.g. thermistors in each motor or individual thermal relays. (Circuit breakers are not suitable as protection).

### 6.4.4 Direction of Motor Rotation

The default setting is clockwise rotation with the frequency converter output connected as follows.

- Terminal 96 connected to U-phase
- Terminal 97 connected to V-phase
- Terminal 98 connected to W-phase

The direction of motor rotation is changed by switching 2 motor phases.

Motor rotation check can be performed using *1-28 Motor Rotation Check* and following the steps shown in the display.

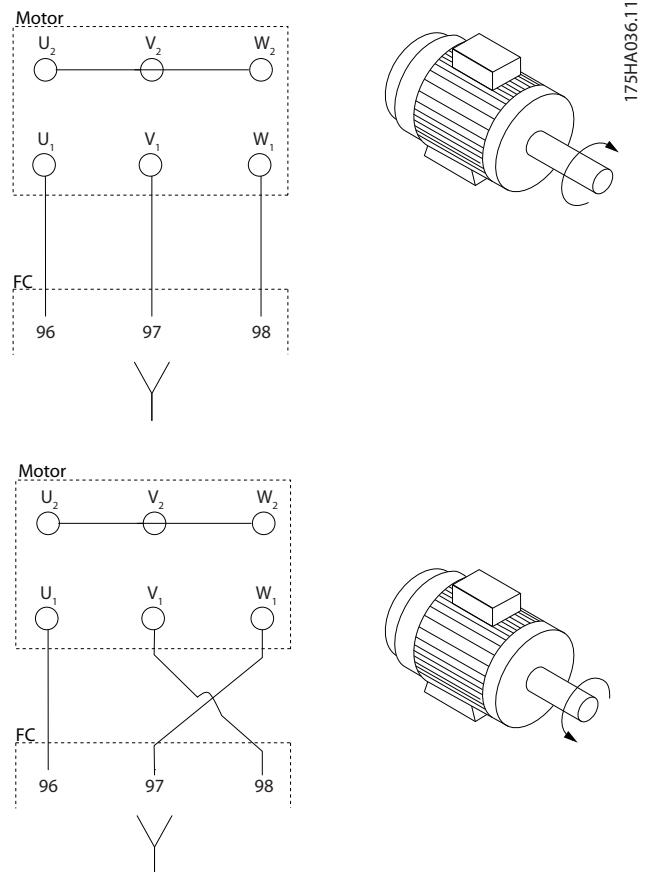

**Illustration 6.42 Motor Rotation Check Steps**

### 6.4.5 Motor Insulation

For motor cable lengths  $\leq$  the maximum cable length listed in *chapter 9 General Specifications and Troubleshooting*, the motor insulation ratings listed in *Table 6.36* are recommended. If a motor has lower insulation rating, it is recommended to use a dU/dt or sine-wave filter.

Nominal Mains Voltage [V]	Motor Insulation [V]
$U_N \leq 420$	Standard $U_{LL} = 1300$
$420 V < U_N \leq 500$	Reinforced $U_{LL} = 1600$
$500 V < U_N \leq 600$	Reinforced $U_{LL} = 1800$
$600 V < U_N \leq 690$	Reinforced $U_{LL} = 2000$

**Table 6.36 Motor Insulation**

## 6.4.6 Motor Bearing Currents

All motors installed with FC 102 90 kW or higher power frequency converter should have NDE (Non-Drive End) insulated bearings installed to eliminate circulating bearing currents. To minimise DE (Drive End) bearing and shaft currents, proper grounding of the frequency converter, motor, driven machine, and motor to the driven machine is required.

### Standard Mitigation Strategies

1. Use an insulated bearing.
2. Apply rigorous installation procedures
  - 2a Ensure the motor and load motor are aligned.
  - 2b Strictly follow the EMC Installation guideline.
  - 2c Reinforce the PE so the high frequency impedance is lower in the PE than the input power leads.
  - 2d Provide a good high frequency connection between the motor and the frequency converter for instance by screened cable which has a 360° connection in the motor and the frequency converter.
  - 2e Make sure that the impedance from frequency converter to building ground is lower than the grounding impedance of the machine. This can be difficult for pumps.
  - 2f Make a direct ground connection between the motor and load motor.
3. Lower the IGBT switching frequency.
4. Modify the inverter waveform, 60° AVM vs. SFAVM.
5. Install a shaft grounding system or use an isolating coupling.
6. Apply conductive lubrication.
7. Use minimum speed settings if possible.
8. Try to ensure the line voltage is balanced to ground. This can be difficult for IT, TT, TN-CS or Grounded leg systems.
9. Use a dU/dt or sinus filter.

## 6.5 Control Cables and Terminals

### 6.5.1 Access to Control Terminals

All terminals to the control cables are located underneath the terminal cover on the front of the frequency converter. Remove the terminal cover by means of a screwdriver (see *Illustration 6.43*).

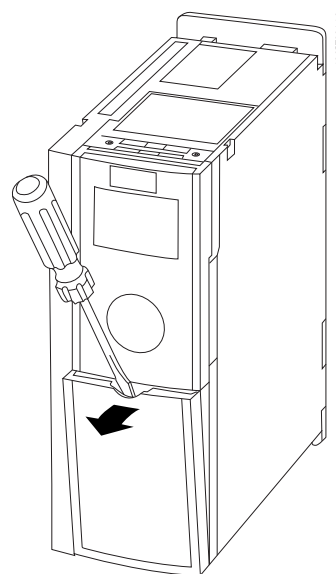

Illustration 6.43 Enclosure Types A1, A2, A3, B3, B4, C3 and C4

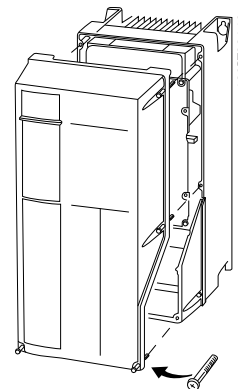

Illustration 6.44 Enclosure Types A5, B1, B2, C1 and C2

### 6.5.2 Control Cable Routing

Tie down all control wires to the designated control cable routing as shown in the picture. Remember to connect the shields in a proper way to ensure optimum electrical immunity.

#### Fieldbus connection

Connections are made to the relevant options on the control card. For details see the relevant fieldbus instruction. The cable must be placed in the provided path

inside the frequency converter and tied down together with other control wires (see *Illustration 6.45*).

In the chassis (IP00) and NEMA 1 units it is also possible to connect the fieldbus from the top of the unit as shown in *Illustration 6.46* and *Illustration 6.47*. On the NEMA 1 unit remove a cover plate.

Kit number for fieldbus top connection: 176F1742

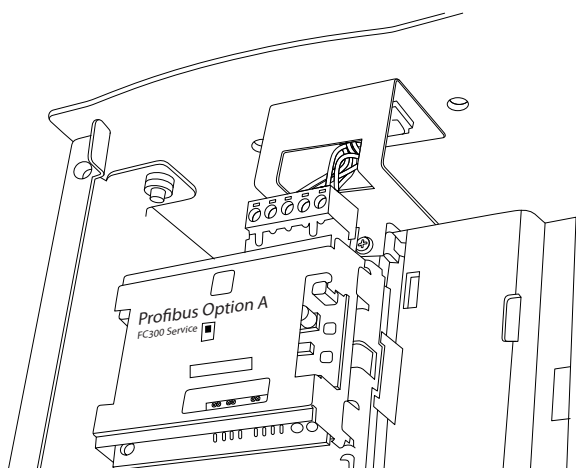

Illustration 6.45 Inside Location of Fieldbus

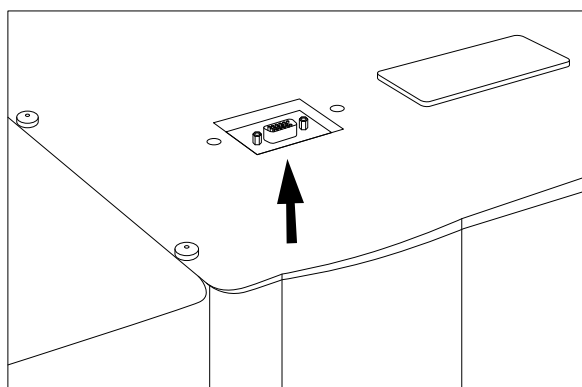

Illustration 6.46 Top Connection for Fieldbus on IP00

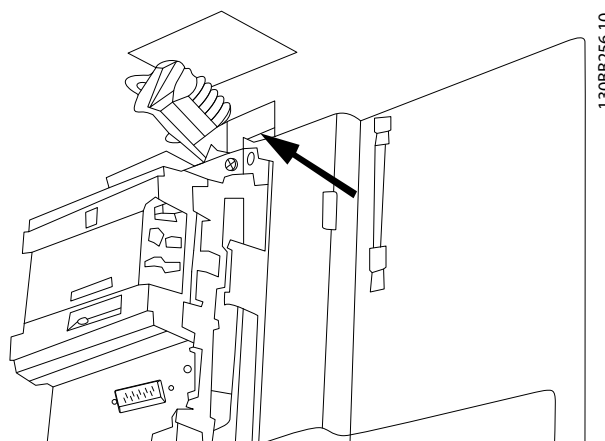

Illustration 6.47 Top Connection for Fieldbus NEMA 1 Units

### Installation of 24 V external DC Supply

Torque: 0.5 - 0.6 Nm (5 in-lbs)

Screw size: M3

No.	Function
35 (-), 36 (+)	24 V external DC supply

Table 6.37 24 V External DC Supply

24 V DC external supply can be used as low-voltage supply to the control card and any option cards installed. This enables full operation of the LCP (including parameter setting) without connection to mains.

### NOTICE

A warning of low voltage is given when 24 V DC has been connected; however, there is no tripping.

### WARNING

Use 24 V DC supply of type PELV to ensure correct galvanic isolation (type PELV) on the control terminals of the frequency converter.

### 6.5.3 Control Terminals

Item	Description
1	8 pole plug digital I/O
2	3 pole plug RS-485 Bus
3	6 pole analog I/O
4	USB Connection

Table 6.38 Legend Table to *Illustration 6.48*, for FC 102

Item	Description
1	10 pole plug digital I/O
2	3 pole plug RS-485 Bus
3	6 pole analog I/O
4	SB Connection

Table 6.39 Legend Table to Illustration 6.48, for FC 102

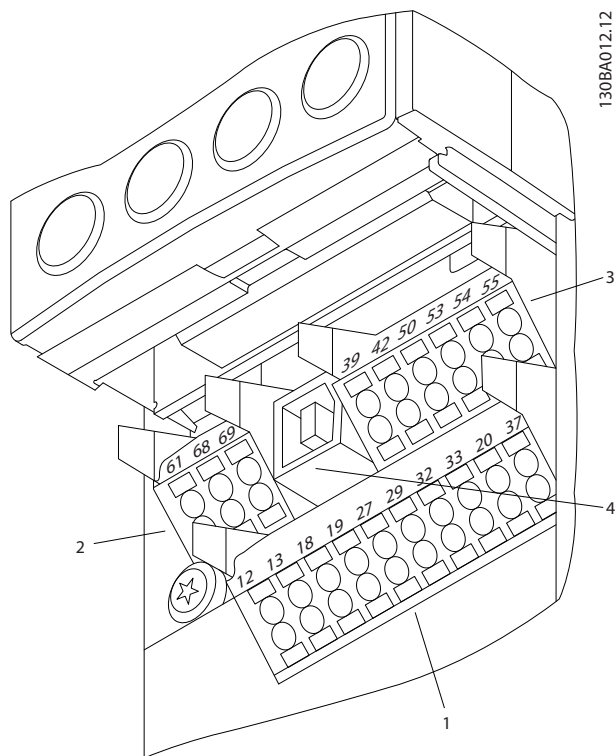

Illustration 6.48 Control Terminals (all Enclosure Types)

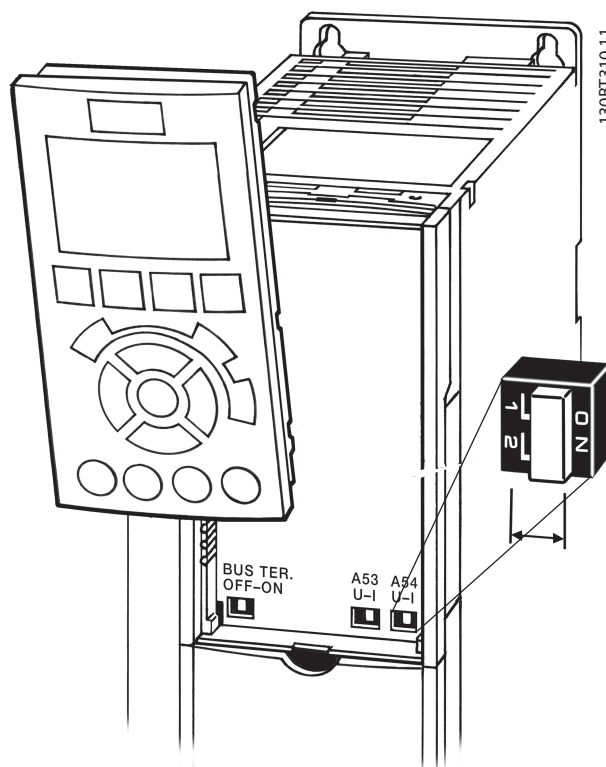

Illustration 6.49 Location of S201, S202 and S801 Switches

6

### 6.5.5 Electrical Installation, Control Terminals

#### To mount the cable to the terminal

1. Strip insulation of 9-10 mm

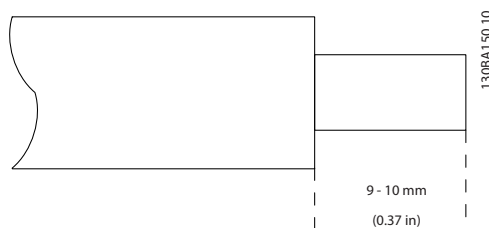

Illustration 6.50 Strip Cable

2. Insert a screwdriver<sup>1)</sup> in the square hole.

### 6.5.4 Switches S201, S202, and S801

Switches S201 (A53) and S202 (A54) are used to select a current (0-20 mA) or a voltage (-10 to 10 V) configuration of the analog input terminals 53 and 54.

Switch S801 (BUS TER.) can be used to enable termination on the RS-485 port (terminals 68 and 69).

#### Default setting

S201 (A53) = OFF (voltage input)

S202 (A54) = OFF (voltage input)

S801 (Bus termination) = OFF

#### **NOTICE**

When changing the function of S201, S202 or S801 be careful not to use force for the switch over. It is recommended to remove the LCP fixture (cradle) when operating the switches. The switches must not be operated with power on the frequency converter.



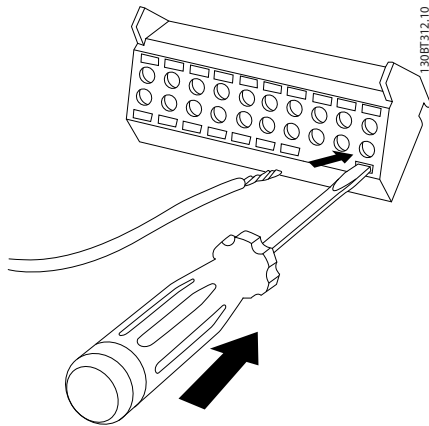

Illustration 6.51 Insert Screwdriver

3. Insert the cable in the adjacent circular hole.

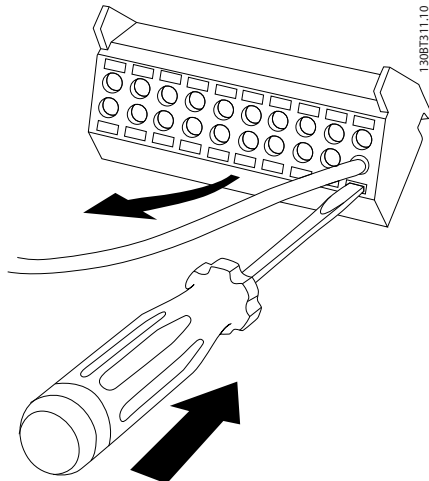

Illustration 6.52 Insert Cable

4. Remove the screwdriver. The cable is now mounted to the terminal.

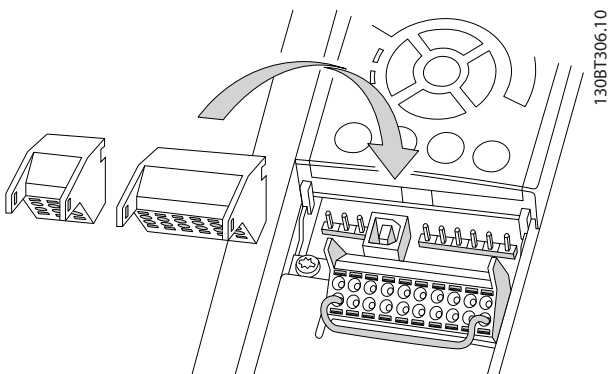

Illustration 6.53 Remove Screwdriver

**To remove the cable from the terminal**

1. Insert a screwdriver<sup>1)</sup> in the square hole.
2. Pull out the cable.

<sup>1)</sup> Max. 0.4 x 2.5 mm

**6.5.6 Basic Wiring Example**

1. Mount terminals from the accessory bag to the front of the frequency converter.
2. Connect terminals 18 and 27 to +24 V (terminal 12/13)

**Default settings**

18 = Start, 5-10 Terminal 18 Digital Input [9]

27 = Stop inverse, 5-12 Terminal 27 Digital Input [6]

37 = Safe Torque Off inverse

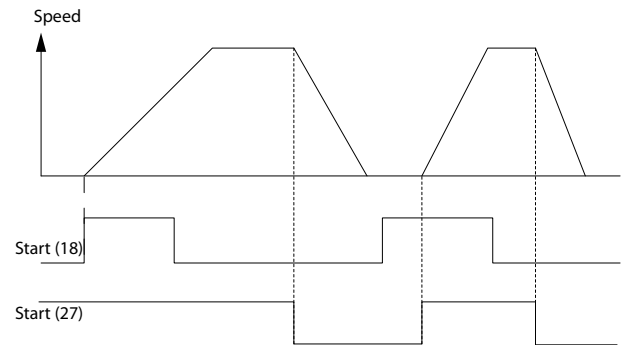
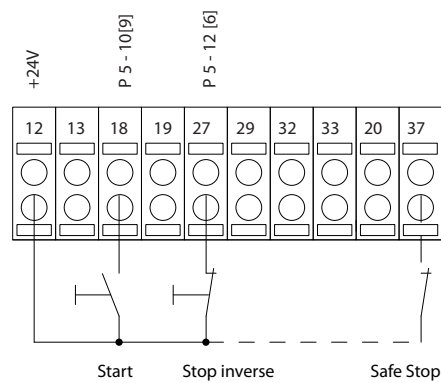

Illustration 6.54 Basic Wiring

130BA156.12

6.5.7 Electrical Installation, Control Cables

6

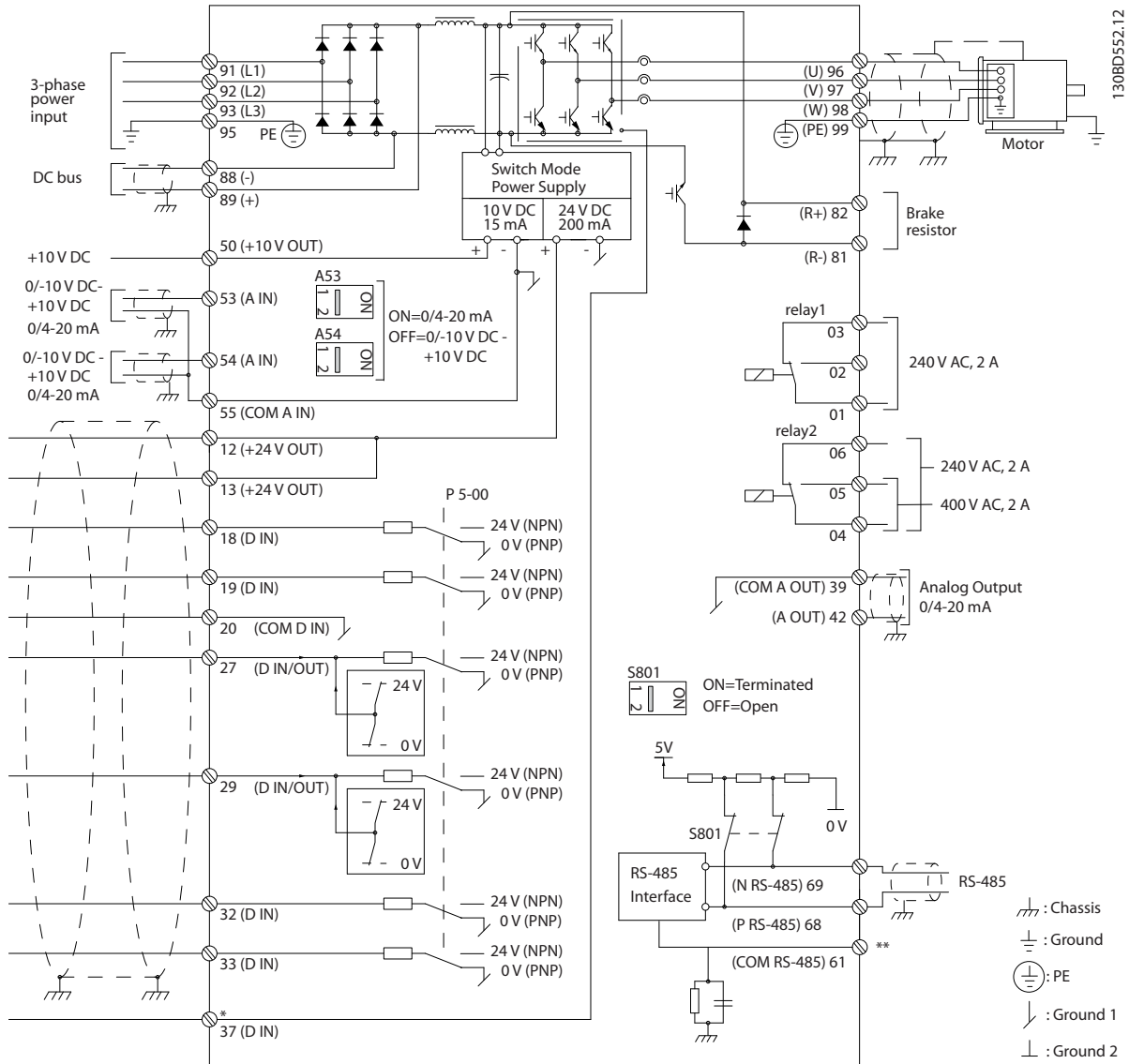

Illustration 6.55 Basic Wiring Schematic

A=Analog, D=Digital

\*Terminal 37 (optional) is used for Safe Torque Off. For Safe Torque Off installation instructions, refer to the *Safe Torque Off Operating Instructions for Danfoss VLT® Frequency Converters*.

\*\*Do not connect cable screen.

Very long control cables and analog signals may in rare cases and depending on installation, result in 50/60 Hz ground loops due to noise from mains supply cables. If this occurs, it may be necessary to break the screen or insert a 100 nF capacitor between screen and chassis. The digital and analog inputs and outputs must be connected separately to the common inputs (terminal 20, 55, 39) of the frequency converter to avoid ground currents from both groups to affect other groups. For example, switching on the digital input may disturb the analog input signal.

Input polarity of control terminals

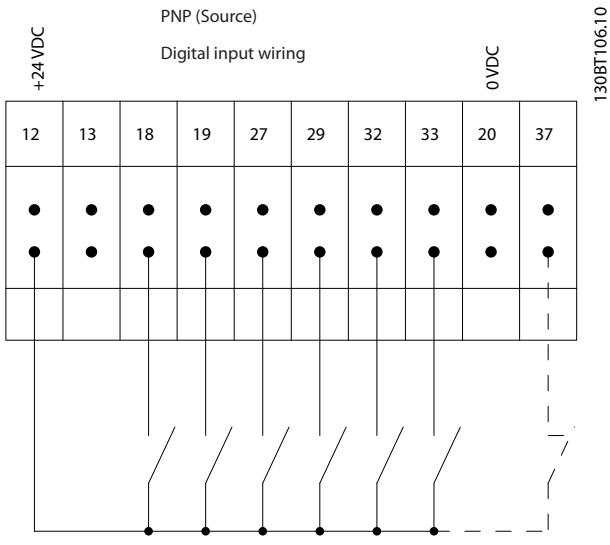

Illustration 6.56 Input Polarity PNP (Source)

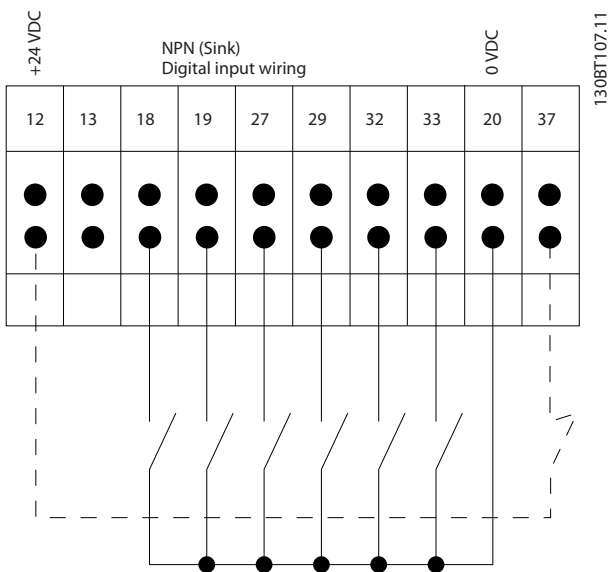

Illustration 6.57 Input Polarity NPN (Sink)

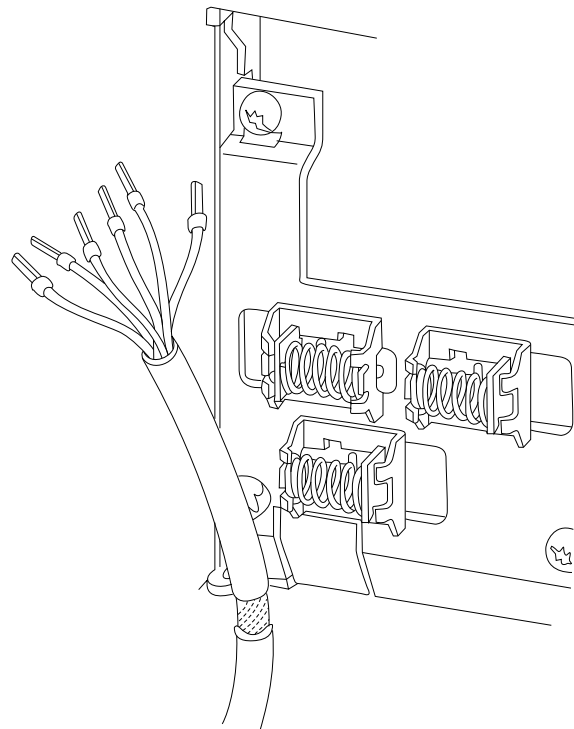

Illustration 6.58 Grounding of Screened/Armoured Control Cables

**NOTICE**

To comply with EMC emission specifications, screened/armoured cables are recommended. If an unscreened/unarmoured cable is used, see *chapter 2.9.2 EMC Test Results*.

### 6.5.8 Relay Output

**Relay 1**

- Terminal 01: common
- Terminal 02: normal open 240 V AC
- Terminal 03: normal closed 240 V AC

**Relay 2 (Not FC 301)**

- Terminal 04: common
- Terminal 05: normal open 400 V AC
- Terminal 06: normal closed 240 V AC

Relay 1 and relay 2 are programmed in 5-40 Function Relay, 5-41 On Delay, Relay, and 5-42 Off Delay, Relay.

Additional relay outputs by using Relay Option Module MCB 105.

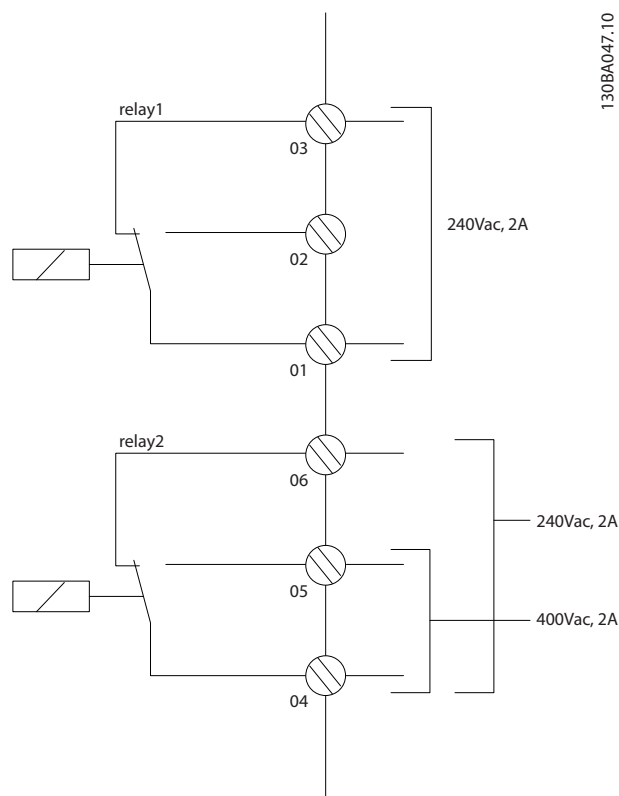

Illustration 6.59 Relay Outputs 1 and 2

130BA047.10

6

### 6.6.2 Load Sharing

Use terminals 88 and 89 for load sharing.

The connection cable must be screened and the max. length from the frequency converter to the DC bar is limited to 25 m (82 ft).

Load sharing enables linking of the DC intermediate circuits of several frequency converters.

**WARNING**

Note that voltages up to 1099 V DC may occur on the terminals.

Load Sharing calls for extra equipment and safety considerations. For further information, see load sharing Instructions.

**WARNING**

Note that mains disconnect may not isolate the frequency converter due to DC-link connection

### 6.6.3 Installation of Brake Cable

The connection cable to the brake resistor must be screened and the max. length from the frequency converter to the DC bar is limited to 25 m (82 ft).

1. Connect the screen by means of cable clamps to the conductive back plate on the frequency converter and to the metal cabinet of the brake resistor.
2. Size the brake cable cross-section to match the brake torque.

Terminals 81 and 82 are brake resistor terminals.

See Brake instructions for more information about safe installation.

**NOTICE**

If a short circuit in the brake IGBT occurs, prevent power dissipation in the brake resistor by using a mains switch or contactor to disconnect the mains for the frequency converter. Only the frequency converter should control the contactor.

**CAUTION**

Note that voltages up to 1099 V DC, depending on the supply voltage, may occur on the terminals.

## 6.6 Additional Connections

### 6.6.1 DC Bus Connection

The DC bus terminal is used for DC back-up, with the intermediate circuit being supplied from an external source. It uses terminals 88 and 89.

For further information, contact Danfoss.

## 6.6.4 How to Connect a PC to the Frequency Converter

To control the frequency converter from a PC, install the MCT 10 Set-up Software.

The PC is connected via a standard (host/device) USB cable, or via the RS-485 interface.

USB is a serial bus utilising 4 shielded wires with Ground pin 4 connected to the shield in the PC USB port. By connecting the PC to a frequency converter through the USB cable, there is a potential risk of damaging the PC USB host controller. All standard PCs are manufactured without galvanic isolation in the USB port.

Any ground potential difference caused by not following the recommendations described in *AC Mains Connection* in the *Operating Instructions*, can damage the USB host controller through the shield of the USB cable.

It is recommended to use a USB isolator with galvanic isolation to protect the PC USB host controller from ground potential differences, when connecting the PC to a frequency converter through a USB cable.

It is recommended not to use a PC power cable with a ground plug when the PC is connected to the frequency converter through a USB cable. It reduces the ground potential difference, but does not eliminate all potential differences due to the ground and shield connected in the PC USB port.

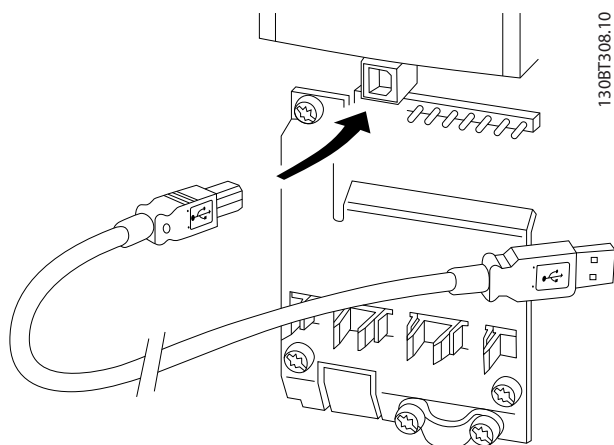

Illustration 6.60 USB Connection

## 6.6.5 PC Software

### Data storage in PC via MCT 10 Set-up Software

1. Connect a PC to the unit via USB com port.
2. Open MCT 10 Set-up Software.
3. Select the USB port in the *network* section.
4. Select *copy*.
5. Select the *project* section.

6. Select *paste*.
7. Select *save as*.

All parameters are now stored.

### Data transfer from PC to frequency converter via MCT 10 Set-up Software

1. Connect a PC to the unit via USB com port.
2. Open MCT 10 Set-up Software.
3. Select *Open* – stored files are shown.
4. Open the appropriate file.
5. Select *Write to drive*.

All parameters are now transferred to the frequency converter.

A separate manual for MCT 10 Set-up Software is available.

## 6.6.6 MCT 31

The MCT 31 harmonic calculation PC tool enables easy estimation of the harmonic distortion in a given application. Both the harmonic distortion of Danfoss frequency converters as well as non-Danfoss frequency converters with additional harmonic reduction devices, such as Danfoss AHF filters and 12-18-pulse rectifiers, can be calculated.

### Ordering number:

Order the CD containing the MCT 31 PC tool using code number 130B1031.

MCT 31 can also be downloaded from [www.danfoss.com/BusinessAreas/DrivesSolutions/SoftwareDownload/](http://www.danfoss.com/BusinessAreas/DrivesSolutions/SoftwareDownload/).

## 6.7 Safety

### 6.7.1 High Voltage Test

Carry out a high voltage test by short-circuiting terminals U, V, W, L<sub>1</sub>, L<sub>2</sub> and L<sub>3</sub>. Energise maximum 2.15 kV DC for 380-500 V frequency converters and 2.525 kV DC for 525-690 V frequency converters for one second between this short-circuit and the chassis.

### **WARNING**

When running high voltage tests of the entire installation, interrupt the mains and motor connection if the leakage currents are too high.

### 6.7.2 Grounding

The following basic issues need to be considered when installing a frequency converter, so as to obtain electro-magnetic compatibility (EMC).

- Safety grounding: The frequency converter has a high leakage current and must be grounded appropriately for safety reasons. Apply local safety regulations.
- High-frequency grounding: Keep the ground wire connections as short as possible.

Connect the different ground systems at the lowest possible conductor impedance. The lowest possible conductor impedance is obtained by keeping the conductor as short as possible and by using the greatest possible surface area.

The metal cabinets of the different devices are mounted on the cabinet rear plate using the lowest possible HF impedance. This avoids having different HF voltages for the individual devices and avoids the risk of radio interference currents running in connection cables that may be used between the devices. The radio interference have been reduced.

To obtain a low HF impedance, use the fastening bolts of the devices as HF connection to the rear plate. It is necessary to remove insulating paint or similar from the fastening points.

### 6.7.3 Safety Ground Connection

The frequency converter has a high leakage current and must be grounded appropriately for safety reasons according to EN 50178.

#### **⚠ WARNING**

The ground leakage current from the frequency converter exceeds 3.5 mA. To ensure a good mechanical connection from the ground cable to the ground connection (terminal 95), the cable cross-section must be at least 10 mm<sup>2</sup> or 2 rated ground wires terminated separately.

### 6.7.4 ADN-compliant Installation

Units with ingress protection rating IP55 (NEMA 12) or higher prevent spark formation, and are classified as limited explosion risk electrical apparatus in accordance with the European Agreement concerning International Carriage of Dangerous Goods by Inland Waterways (ADN).

For units with ingress protection rating IP20, IP21, or IP54, prevent risk of spark formation as follows:

- Do not install a mains switch
- Ensure that 14-50 RFI Filter is set to [1] On.

- Remove all relay plugs marked "RELAY". See Illustration 6.61.
- Check which relay options are installed, if any. The only permitted relay option is Extended Relay Card MCB 113.

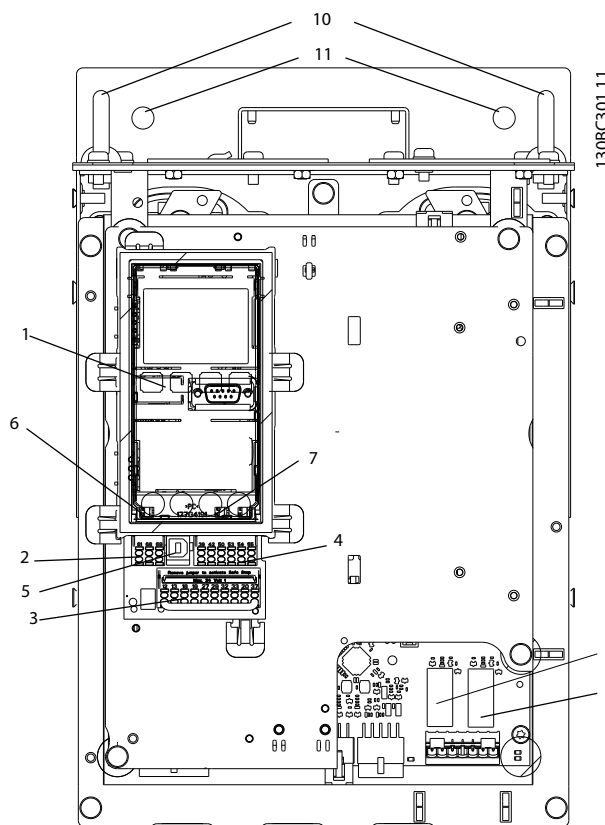

Illustration 6.61 Location of Relay Plugs, Pos. 8 and 9

Manufacturer declaration is available upon request.

## 6.8 EMC-correct Installation

### 6.8.1 Electrical Installation - EMC Precautions

The following is a guideline to good engineering practice when installing frequency converters. Follow these guidelines to comply with EN 61800-3 *First environment*. If the installation is in EN 61800-3 *Second environment*, i.e. industrial networks, or in an installation with its own transformer, deviation from these guidelines is allowed but not recommended. See also paragraphs *chapter 2.2 CE Labelling*, *chapter 2.9 General Aspects of EMC* and *chapter 2.9.2 EMC Test Results*.

#### Good engineering practice to ensure EMC-correct electrical installation

- Use only braided screened/armoured motor cables and braided screened/armoured control cables. The screen should provide a minimum coverage of 80%. The screen material must be

- metal, not limited to, but typically copper, aluminium, steel or lead. There are no special requirements for the mains cable.
- Installations using rigid metal conduits are not required to use screened cable, but the motor cable must be installed in conduit separate from the control and mains cables. Full connection of the conduit from the frequency converter to the motor is required. The EMC performance of flexible conduits varies a lot and information from the manufacturer must be obtained.
- Connect the screen/armour/conduit to ground at both ends for motor cables as well as for control cables. In some cases, it is not possible to connect the screen in both ends. If so, connect the screen at the frequency converter. See also *chapter 6.8.3 Grounding of Screened Control Cables*.
- Avoid terminating the screen/armour with twisted ends (pigtailed). It increases the high frequency impedance of the screen, which reduces its effectiveness at high frequencies. Use low

impedance cable clamps or EMC cable glands instead.

- Avoid using unscreened/unarmoured motor or control cables inside cabinets housing the frequency converter(s).

Leave the screen as close to the connectors as possible.

*Illustration 6.62* shows an example of an EMC-correct electrical installation of an IP20 frequency converter. The frequency converter is fitted in an installation cabinet with an output contactor and connected to a PLC, which is installed in a separate cabinet. Other ways of doing the installation may have just as good an EMC performance, provided the above guide lines to engineering practice are followed.

If the installation is not carried out according to the guideline, and if unscreened cables and control wires are used, some emission requirements are not complied with, although the immunity requirements are fulfilled. See *chapter 2.9.2 EMC Test Results*.

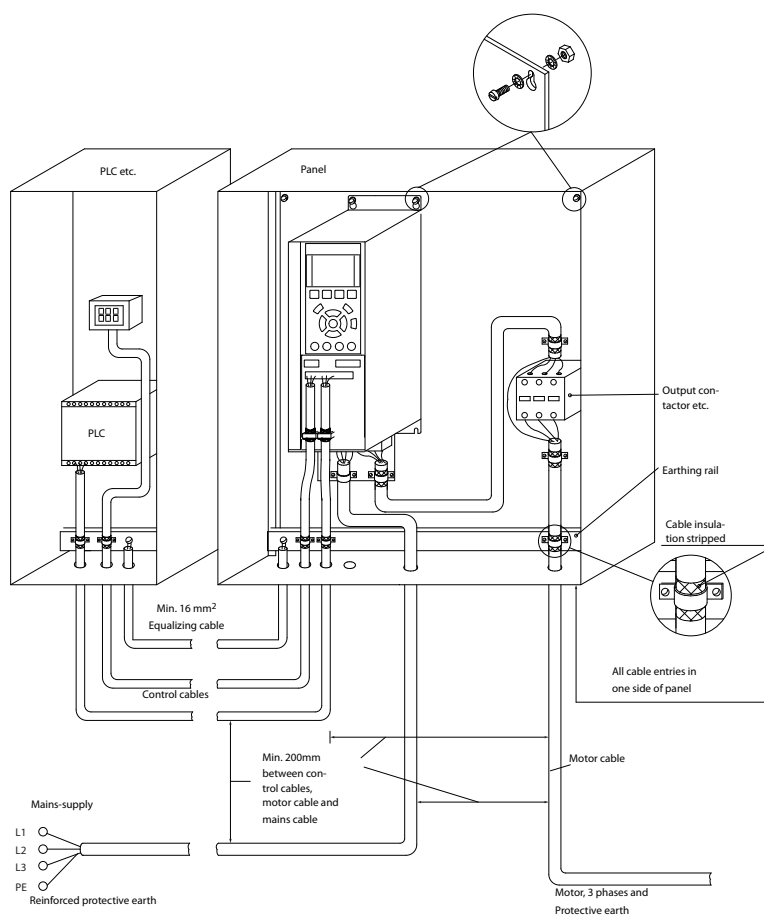

Illustration 6.62 EMC-correct Electrical Installation of a Frequency Converter in Cabinet

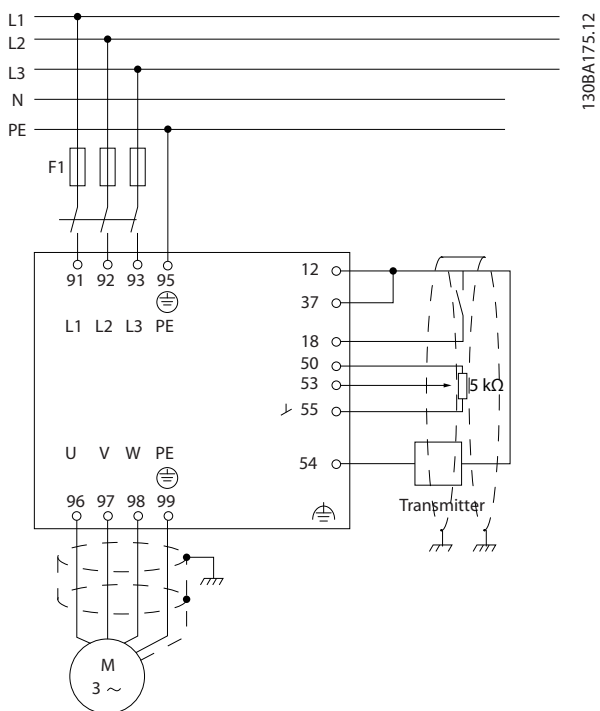

Illustration 6.63 Electrical Connection Diagram

### 6.8.2 Use of EMC-Correct Cables

Danfoss recommends braided screened/armoured cables to optimise EMC immunity of the control cables and the EMC emission from the motor cables.

The ability of a cable to reduce the in- and outgoing radiation of electric noise depends on the transfer impedance ( $Z_T$ ). The screen of a cable is normally designed to reduce the transfer of electric noise; however, a screen with a lower transfer impedance ( $Z_T$ ) value is more effective than a screen with a higher transfer impedance ( $Z_T$ ).

Transfer impedance ( $Z_T$ ) is rarely stated by cable manufacturers, but it is often possible to estimate transfer impedance ( $Z_T$ ) by assessing the physical design of the cable.

**Transfer impedance ( $Z_T$ ) can be assessed on the basis of the following factors:**

- The conductivity of the screen material
- The contact resistance between the individual screen conductors
- The screen coverage, i.e. the physical area of the cable covered by the screen - often stated as a percentage value
- Screen type, i.e. braided or twisted pattern

- Aluminium-clad with copper wire
- Twisted copper wire or armoured steel wire cable
- Single-layer braided copper wire with varying percentage screen coverage  
This is the typical Danfoss reference cable
- Double-layer braided copper wire
- Twin layer of braided copper wire with a magnetic, screened/armoured intermediate layer
- Cable that runs in copper tube or steel tube
- Lead cable with 1.1 mm wall thickness

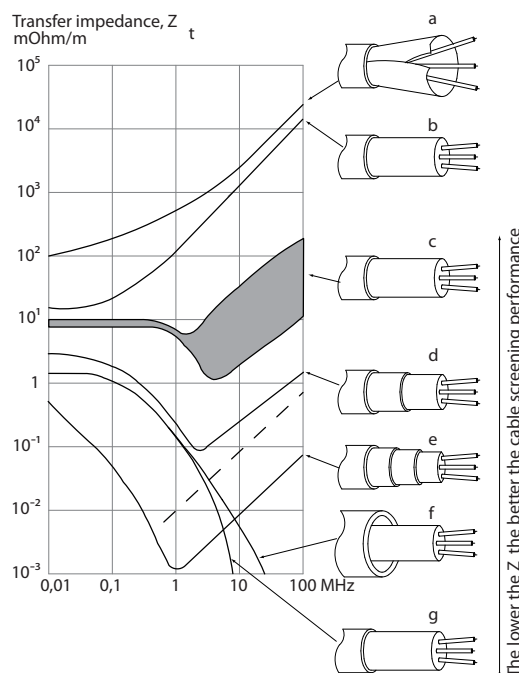

Illustration 6.64 Transfer Impedance

175ZA166.13



### 6.8.3 Grounding of Screened Control Cables

#### Correct screening

The preferred method in most cases is to secure control and cables with screening clamps provided at both ends to ensure best possible high frequency cable contact. If the ground potential between the frequency converter and the PLC is different, electric noise may occur that disturbs the entire system. Solve this problem by fitting an equalising cable next to the control cable. Minimum cable cross section: 16 mm<sup>2</sup>.

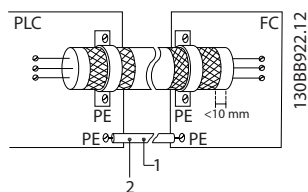

Illustration 6.65 Control Cable with Equalising Cable

1	Min. 16 mm <sup>2</sup>
2	Equalizing cable

Table 6.40 Legend to Illustration 6.65

#### 50/60 Hz ground loops

With very long control cables, ground loops may occur. To eliminate ground loops, connect one end of the screen-to-ground with a 100 nF capacitor (keeping leads short).

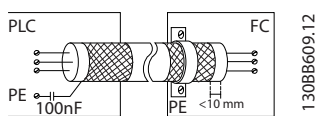

Illustration 6.66 Screen-to-ground Connected to a 100 nF Capacitor

#### Avoid EMC noise on serial communication

This terminal is connected to ground via an internal RC link. Use twisted-pair cables to reduce interference between conductors.

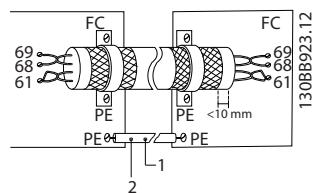

Illustration 6.67 Twisted-pair Cables

1	Min. 16 mm <sup>2</sup>
2	Equalizing cable

Table 6.41 Legend to Illustration 6.67

Alternatively, the connection to terminal 61 can be omitted:

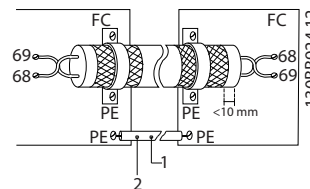

Illustration 6.68 Terminal 61 not Connected

1	Min. 16 mm <sup>2</sup>
2	Equalizing cable

Table 6.42 Legend to Illustration 6.68

### 6.8.4 RFI Switch

#### Mains supply isolated from ground

If the frequency converter is supplied from an isolated mains source (IT mains, floating delta) or TT/TN-S mains with grounded leg (grounded delta), turn off the RFI switch via 14-50 RFI Filter.

In OFF, the internal capacitors between the chassis (ground), the input RFI filter and the intermediate circuit are cut off. As the RFI switch is turned off, the frequency converter is not be able to meet optimum EMC performance.

By opening the RFI filter switch, the ground leakage currents are also reduced, but not the high-frequency leakage currents caused by the switching of the inverter. It is important to use isolation monitors that are capable for use with power electronics (IEC61557-8). E.g. Deif type SIM-Q, Bender type IRDH 275/375 or similar.

Also refer to the application note *VLT on IT mains*.

#### NOTICE

If the RFI switch is not turned off, and the frequency converter is running on isolated grids, ground faults can potentially lead to charge-up of the intermediate circuit and cause DC capacitor damage or result in reduced product life.

## 6.9 Residual Current Device

Use RCD relays, multiple protective grounding as extra protection, provided that local safety regulations are complied with.

If a ground fault appears, a DC content may develop in the faulty current.

If RCD relays are used, observe local regulations. Relays must be suitable for protection of 3-phase equipment with a bridge rectifier and for a brief discharge on power-up see *chapter 2.11 Earth Leakage Current* for further information.

## 6.10 Final Set-up and Test

To test the set-up and ensure that the frequency converter is running, follow these steps.

### Step 1. Locate the motor name plate

#### **NOTICE**

The motor is either star- (Y) or delta- connected ( $\Delta$ ). This information is located on the motor name plate data.

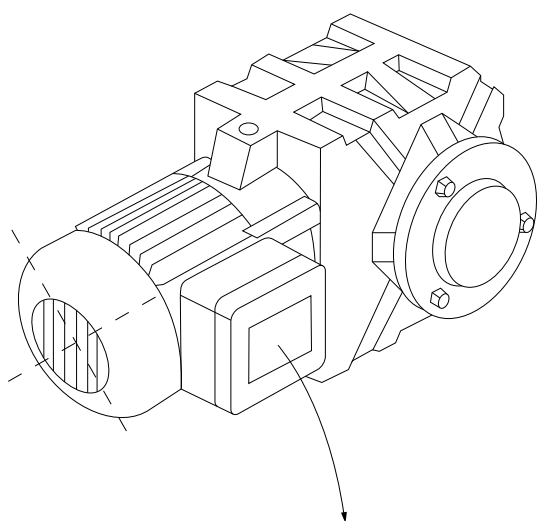

BAUER D-7 3734 ESLINGEN				
3~ MOTOR NR. 1827421 2003				
S/E005A9				
	1,5	KW		
n <sub>2</sub>	31,5	/min.	400	Y V
n <sub>1</sub>	1400	/min.	50	Hz
COS $\theta$		0,80	3,6	A
1,7L				
B	IP 65	H1/1A		

Illustration 6.69 Motor Name Plate

### Step 2. Enter the motor name plate data in this parameter list.

To access this list, press [Quick Menu] and select "Q2 Quick Setup".

- 1-20 Motor Power [kW].  
1-21 Motor Power [HP].
- 1-22 Motor Voltage.
- 1-23 Motor Frequency.
- 1-24 Motor Current.
- 1-25 Motor Nominal Speed.

### Step 3. Activate the Automatic Motor Adaptation (AMA)

Performing an AMA ensures optimum performance. The AMA measures the values from the motor model equivalent diagram.

1. Connect terminal 37 to terminal 12 (if terminal 37 is available).
2. Connect terminal 27 to terminal 12 or set 5-12 Terminal 27 Digital Input to [0] No function.
3. Activate the AMA 1-29 Automatic Motor Adaptation (AMA).
4. Select between complete or reduced AMA. If a Sine-wave filter is mounted, run only the reduced AMA, or remove the Sine-wave filter during the AMA procedure.
5. Press [OK]. The display shows *Press [Hand on] to start*.
6. Press [Hand On]. A progress bar indicates, if the AMA is in progress.

### Stop the AMA during operation

1. Press [Off] - the frequency converter enters alarm mode and the display shows that the AMA was terminated by the user.

### Successful AMA

1. The display shows *Press [OK] to finish AMA*.
2. Press [OK] to exit the AMA state.

### Unsuccessful AMA

1. The frequency converter enters alarm mode. A description of the alarm can be found in the *Warnings and Alarms* chapter in product related *Operating Instructions*.
2. *Report Value* in the [Alarm Log] shows the last measuring sequence carried out by the AMA, before the frequency converter entered alarm mode. This number along with the description of the alarm assist in troubleshooting. If contacting Danfoss for service, make sure to mention number and alarm description.

**NOTICE**

Unsuccessful AMA is often caused by incorrectly registered motor name plate data, or a too big difference between the motor power size and the frequency converter power size.

**Step 4. Set speed limit and ramp times**

Set up the desired limits for speed and ramp time:

*3-02 Minimum Reference.*

*3-03 Maximum Reference.*

*4-11 Motor Speed Low Limit [RPM] or 4-12 Motor Speed Low Limit [Hz].*

*4-13 Motor Speed High Limit [RPM] or 4-14 Motor Speed High Limit [Hz].*

*3-41 Ramp 1 Ramp Up Time.*

*3-42 Ramp 1 Ramp Down Time.*

# 7 Application Examples

## 7.1 Application Examples

### 7.1.1 Start/Stop

Terminal 18 = start/stop 5-10 Terminal 18 Digital Input [8] Start

Terminal 27 = No operation 5-12 Terminal 27 Digital Input [0] No operation (Default coast inverse)

5-10 Terminal 18 Digital Input = Start (default)

5-12 Terminal 27 Digital Input = coast inverse (default)

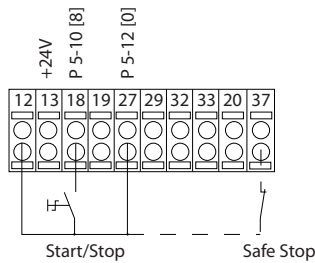

130BA155.12

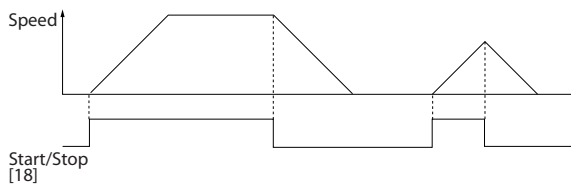

Illustration 7.1 Terminal 37: Available only with Safe Stop Function

### 7.1.2 Pulse Start/Stop

Terminal 18 = start/stop 5-10 Terminal 18 Digital Input [9] Latched start

Terminal 27 = Stop 5-12 Terminal 27 Digital Input [6] Stop inverse

5-10 Terminal 18 Digital Input = Latched start

5-12 Terminal 27 Digital Input = Stop inverse

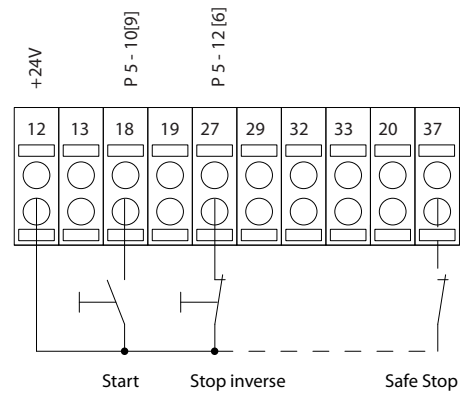

130BA156.12

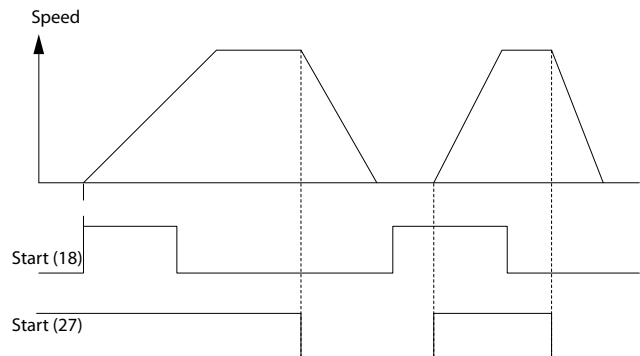

Illustration 7.2 Terminal 37: Available Only with Safe Torque Off Function

### 7.1.3 Potentiometer Reference

Voltage reference via a potentiometer.

- 3-15 Reference 1 Source [1] = Analog Input 53
- 6-10 Terminal 53 Low Voltage = 0 V
- 6-11 Terminal 53 High Voltage = 10 V
- 6-14 Terminal 53 Low Ref./Feedb. Value = 0 RPM
- 6-15 Terminal 53 High Ref./Feedb. Value = 1.500 RPM
- Switch S201 = OFF (U)

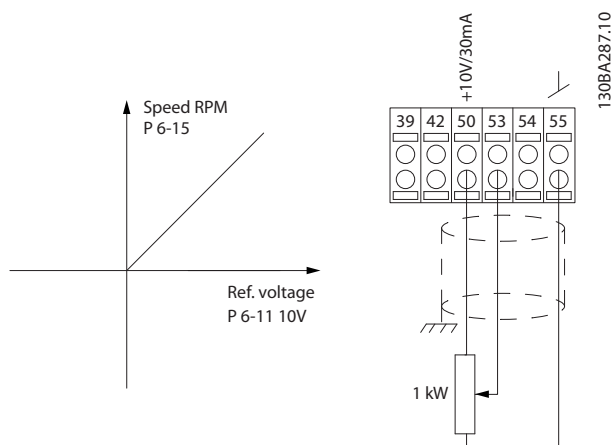

Illustration 7.3 Voltage Reference via a Potentiometer

### 7.1.4 Automatic Motor Adaptation (AMA)

AMA is an algorithm to measure the electrical motor parameters on a motor at standstill. This means that AMA itself does not supply any torque. AMA is useful when commissioning systems and optimising the adjustment of the frequency converter to the applied motor. This feature is particularly used where the default setting does not apply to the connected motor. 1-29 Automatic Motor Adaptation (AMA) allows a choice of complete AMA with determination of all electrical motor parameters or reduced AMA with determination of the stator resistance  $R_s$  only. The duration of a total AMA varies from a few minutes on small motors to more than 15 minutes on large motors.

**Limitations and preconditions:**

- For the AMA to determine the motor parameters optimally, enter the correct motor nameplate data in 1-20 Motor Power [kW] to 1-28 Motor Rotation Check.
- For the best adjustment of the frequency converter, carry out AMA on a cold motor. Repeated AMA runs may lead to a heating of the motor, which results in an increase of the stator resistance,  $R_s$ . Normally, this is not critical.

- AMA can only be carried out if the rated motor current is minimum 35% of the rated output current of the frequency converter. AMA can be carried out on up to one oversize motor.
- It is possible to carry out a reduced AMA test with a Sine-wave filter installed. Avoid carrying out a complete AMA with a Sine-wave filter. If an overall setting is required, remove the Sine-wave filter while running a total AMA. After completion of the AMA, reinsert the Sine-wave filter.
- If motors are coupled in parallel, use only reduced AMA if any.
- Avoid running a complete AMA when using synchronous motors. If synchronous motors are applied, run a reduced AMA and manually set the extended motor data. The AMA function does not apply to permanent magnet motors.
- The frequency converter does not produce motor torque during an AMA. During an AMA, it is imperative that the application does not force the motor shaft to run, which is known to happen with e.g. wind milling in ventilation systems. This disturbs the AMA function.
- AMA cannot be activated when running a PM motor (when 1-10 Motor Construction is set to [1] PM non salient SPM).

### 7.1.5 Smart Logic Control

A useful facility in the frequency converter is the Smart Logic Control (SLC). In applications where a PLC is generating a simple sequence the SLC may take over elementary tasks from the main control. SLC is designed to act from event send to or generated in the frequency converter. The frequency converter then performs the pre-programmed action.

### 7.1.6 Smart Logic Control Programming

The Smart Logic Control (SLC) is essentially a sequence of user-defined actions (see 13-52 SL Controller Action) executed by the SLC when the associated user-defined event (see 13-51 SL Controller Event) is evaluated as TRUE by the SLC. Events and actions are each numbered and are linked in pairs called states. This means that when event [1] is fulfilled (attains the value TRUE), action [1] is executed. After this, the conditions of event [2] is evaluated, and if evaluated TRUE, action [2] is executed and so on. Events and actions are placed in array parameters.

Only one event will be evaluated at any time. If an event is evaluated as FALSE, nothing happens (in the SLC) during

the present scan interval and no other events are evaluated. This means that when the SLC starts, it evaluates event [1] (and only event [1]) each scan interval. Only when event [1] is evaluated TRUE, the SLC executes action [1] and starts evaluating event [2].

It is possible to program from 0 to 20 events and actions. When the last event/action has been executed, the sequence starts over again from event [1]/action [1]. Illustration 7.4 shows an example with three events/actions:

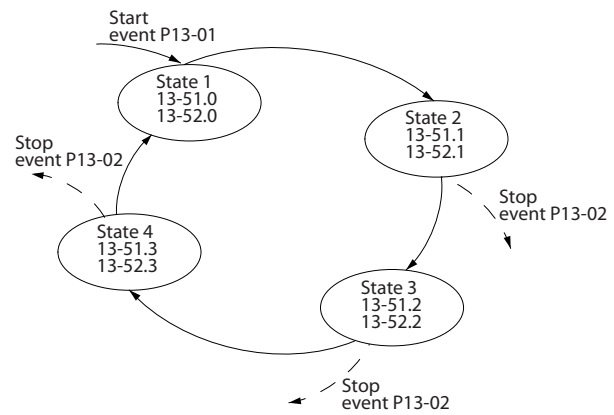

Illustration 7.4 An Example with Three Events/Actions

130BA062.14

### 7.1.7 SLC Application Example

7

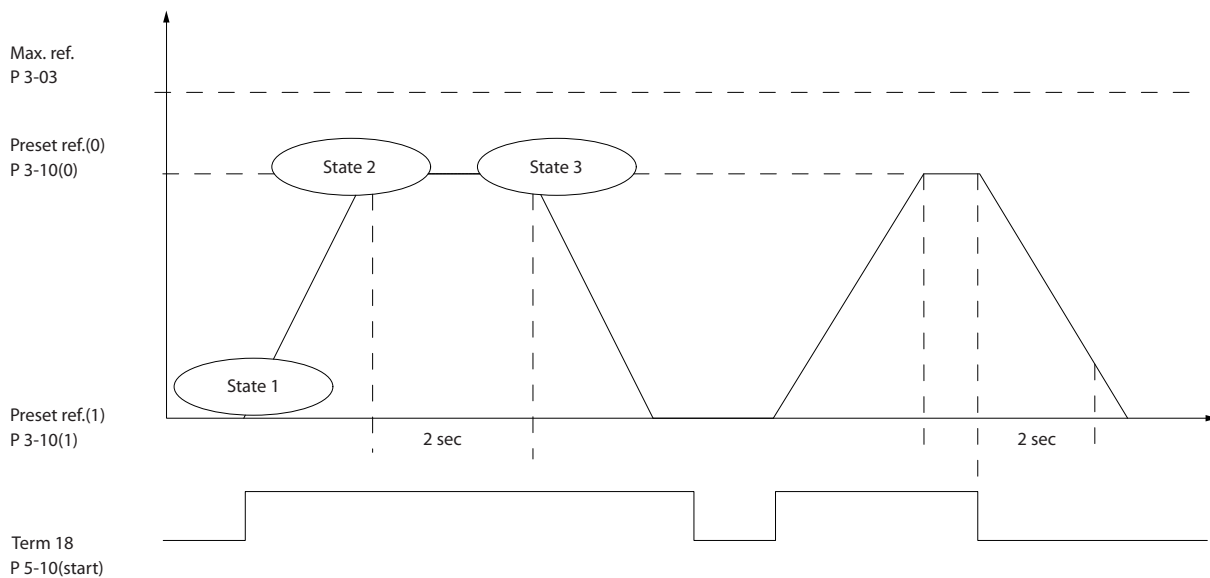

Illustration 7.5 One sequence 1: Start – ramp up – run at reference speed 2 sec – ramp down and hold shaft until stop

130BA157.11

Set the ramping times in 3-41 Ramp 1 Ramp Up Time and 3-42 Ramp 1 Ramp Down Time to the wanted times

$$tramp = \frac{tacc \times nnorm(par. 1 - 25)}{ref[RPM]}$$

Set term 27 to No Operation (5-12 Terminal 27 Digital Input)

Set Preset reference 0 to first preset speed (3-10 Preset Reference [0]) in percentage of Max reference speed (3-03 Maximum Reference). Ex.: 60%

Set preset reference 1 to second preset speed (3-10 Preset Reference [1] Ex.: 0 % (zero).

Set the timer 0 for constant running speed in 13-20 SL Controller Timer [0]. Ex.: 2 sec.

- Set Event 1 in 13-51 SL Controller Event [1] to True [1]
- Set Event 2 in 13-51 SL Controller Event [2] to On Reference [4]
- Set Event 3 in 13-51 SL Controller Event [3] to Time Out 0 [30]
- Set Event 4 in 13-51 SL Controller Event [4] to False [0]

- Set Action 1 in 13-52 SL Controller Action [1] to Select preset 0 [10]
- Set Action 2 in 13-52 SL Controller Action [2] to Start Timer 0 [29]
- Set Action 3 in 13-52 SL Controller Action [3] to Select preset 1 [11]
- Set Action 4 in 13-52 SL Controller Action [4] to No Action [1]

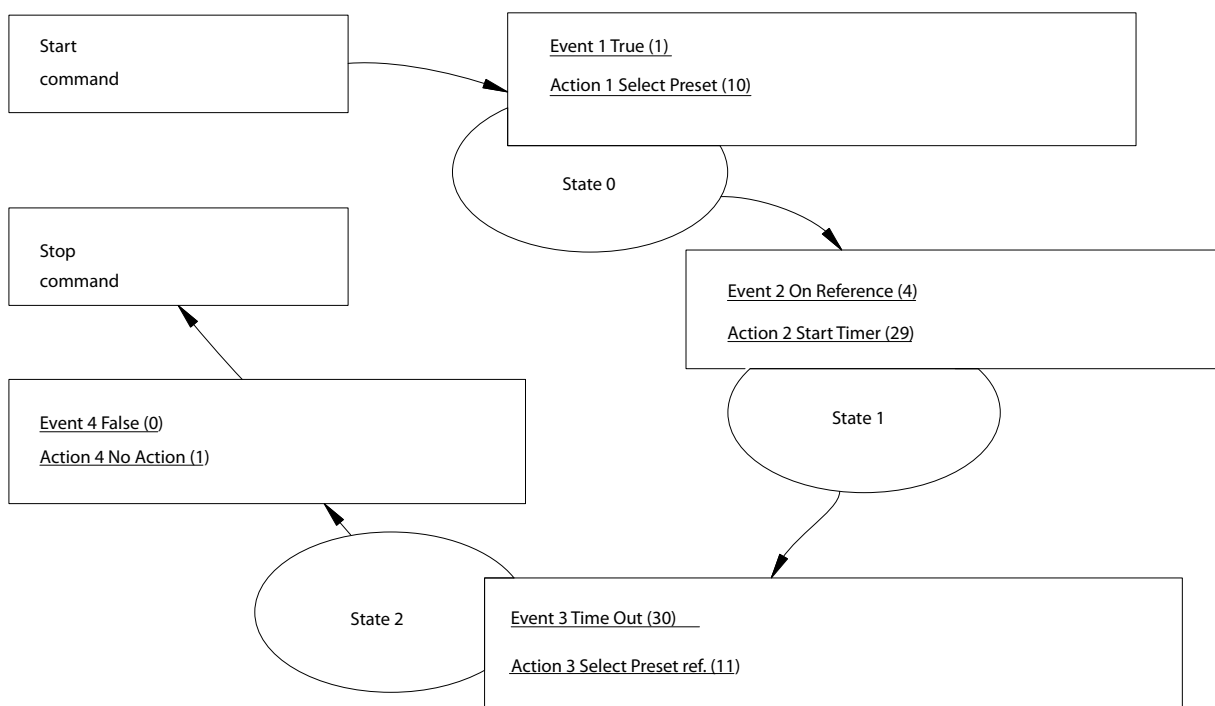

130BAT48.12

Illustration 7.6 Set Event and Action

Set the Smart Logic Control in 13-00 SL Controller Mode to ON.

Start/stop command is applied on terminal 18. If stop signal is applied the frequency converter will ramp down and go into free mode.

### 7.1.8 Cascade Controller

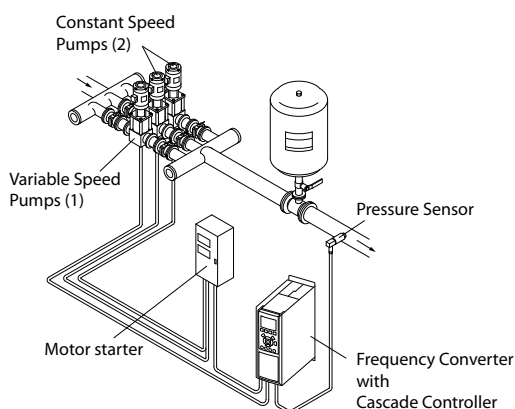

130BA362.10

Illustration 7.7 A Pump Application

The Cascade Controller is used for pump applications where a certain pressure (“head”) or level needs to be maintained over a wide dynamic range. Running a large pump at variable speed over a wide for range is not an

ideal solution because of low pump efficiency and because there is a practical limit of about 25% rated full load speed for running a pump.

In the Cascade Controller the frequency converter controls a variable speed motor as the variable speed pump (lead) and can stage up to 2 additional constant speed pumps on and off. By varying the speed of the initial pump, variable speed control of the entire system is provided. This maintains constant pressure while eliminating pressure surges, resulting in reduced system stress and quieter operation in pumping systems.

#### Fixed Lead Pump

The motors must be of equal size. The Cascade Controller allows the frequency converter to control up to 5 equal size pumps using the frequency converters 2 built-in relays and terminal 27, 29 (DI/DO). When the variable pump (lead) is connected directly to the frequency converter, the other 4 pumps are controlled by the two built-in relays and terminal 27, 29 (DI/DO). Lead pump alternation cannot be selected when lead pump is fixed.

#### Lead Pump Alternation

The motors must be of equal size. This function makes it possible to cycle the frequency converter between the pumps in the system (when 25-57 Relays per Pump =1, maximum pump is 4. When 25-57 Relays per Pump =2, maximum pump is 3). In this operation, the run time between pumps is equalized reducing the required pump maintenance and increasing reliability and lifetime of the

system. The alternation of the lead pump can take place at a command signal or at staging (adding lag pump).

The command can be a manual alternation or an alternation event signal. If the alternation event is selected, the lead pump alternation takes place every time the event occurs. Selections include whenever an alternation timer expires, when the lead pump goes into sleep mode. Staging is determined by the actual system load.

25-55 Alternate if Load  $\leq 50\%$  = 1, if load  $>50\%$  alternation does not happen. If load  $\leq 50\%$  Alternation happens. When 25-55 Alternate if Load  $\leq 50\%$  = 0, Alternation happens no matter with Load. Total pump capacity is determined as lead pump plus lag speed pumps capacities.

**Bandwidth Management**

In cascade control systems, to avoid frequent switching of fixed speed pumps, the desired system pressure is kept within a bandwidth rather than at a constant level. The staging bandwidth provides the required bandwidth for operation. When a large and quick change in system pressure occurs, the override bandwidth overrides the staging bandwidth to prevent immediate response to a short duration pressure change. An override bandwidth timer can be programmed to prevent staging until the system pressure has stabilised and normal control established.

When the Cascade Controller is enabled and running normally, and the frequency converter issues a trip alarm, the system head is maintained by staging and destaging fixed speed pumps. To prevent frequent staging and destaging and minimise pressure fluxuations, a wider fixed speed bandwidth is used instead of the staging bandwidth.

**7.1.9 Pump Staging with Lead Pump Alternation**

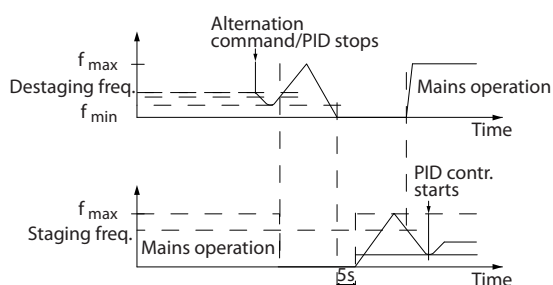

Illustration 7.8 Pump Staging with Lead Pump Alternation

130BA364.10

With lead pump alternation enabled, a maximum of 2 pumps are controlled. At an alternation command, the lead pump ramps to minimum frequency ( $f_{min}$ ) and after a delay will ramp to maximum frequency ( $f_{max}$ ). When the speed of the lead pump reaches the destaging frequency, the fixed speed pump is cut out (de-staged). The lead pump continues to ramp up and then ramps down to a stop and the 2 relays are cut out.

After a time delay, the relay for the fixed speed pump cuts in (staged) and this pump becomes the new lead pump. The new lead pump ramps up to maximum speed and then down to minimum speed. When ramping down and reaching the staging frequency, the old lead pump is now cut in (staged) on the mains as the new fixed speed pump.

If the lead pump has been running at minimum frequency ( $f_{min}$ ) for a programmed amount of time, with a fixed speed pump running, the lead pump contributes little to the system. When the programmed value of the timer expires, the lead pump is removed, avoiding a deal heat water circulation problem.

**7.1.10 System Status and Operation**

If the lead pump goes into Sleep Mode, the function is displayed on the LCP. It is possible to alternate the lead pump on a Sleep Mode condition.

When the Cascade Controller is enabled, the operation status for each pump and the Cascade Controller is displayed on the LCP. Information displayed includes:

- Pumps Status, is a readout of the status for the relays assigned to each pump. The display shows pumps that are disabled, off, running on the frequency converter or running on the mains/motor starter.
- Cascade Status, is a readout of the status for the Cascade Controller. The display shows the Cascade Controller is disabled, all pumps are off, and emergency has stopped all pumps, all pumps are running, fixed speed pumps are being staged/de-staged and lead pump alternation is occurring.
- De-stage at No-Flow ensures that all fixed speed pumps are stopped individually until the no-flow status disappears.





### 7.1.11 Fixed Variable Speed Pump Wiring Diagram

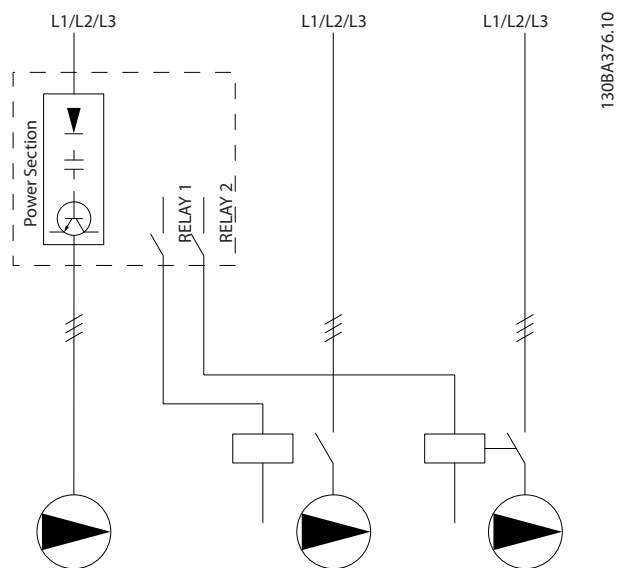

Illustration 7.9 Fixed Variable Speed Pump Wiring Diagram

- K1 blocks for K2 via the mechanical interlock preventing mains to be connected to the output of the frequency converter. (via K1).
- Auxiliary break contact on K1 prevents K3 to cut in.
- RELAY 2 controls contactor K4 for on/off control of the fixed speed pump.
- At alternation both relays de-energises and now RELAY 2 is energised as the first relay.

7

### 7.1.12 Lead Pump Alternation Wiring Diagram

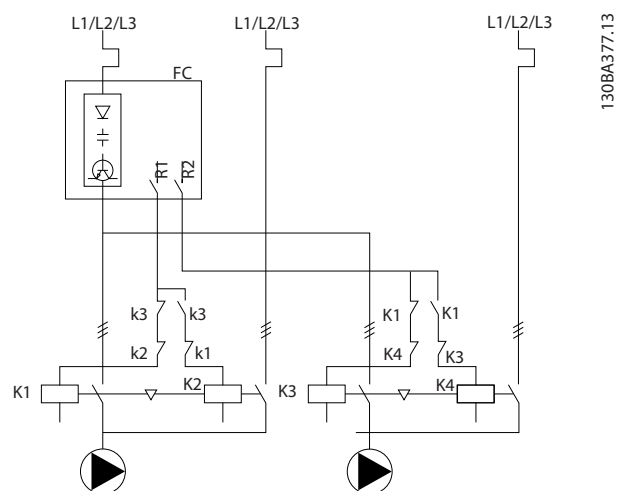

Illustration 7.10 Lead Pump Alternation Wiring Diagram

Every pump must be connected to 2 contactors (K1/K2 and K3/K4) with a mechanical interlock. Thermal relays or other motor protection devices must be applied according to local regulation and/or individual demands.

- RELAY 1 (R1) and RELAY 2 (R2) are the built-in relays in the frequency converter.
- When all relays are de-energised, the first built in relay to be energised cuts in the contactor corresponding to the pump controlled by the relay. E.g. RELAY 1 cuts in contactor K1, which becomes the lead pump.

### 7.1.13 Cascade Controller Wiring Diagram

The wiring diagram shows an example with the built-in BASIC Cascade Controller with one variable speed pump (lead) and 2 fixed speed pumps, a 4-20 mA transmitter and System Safety Interlock.

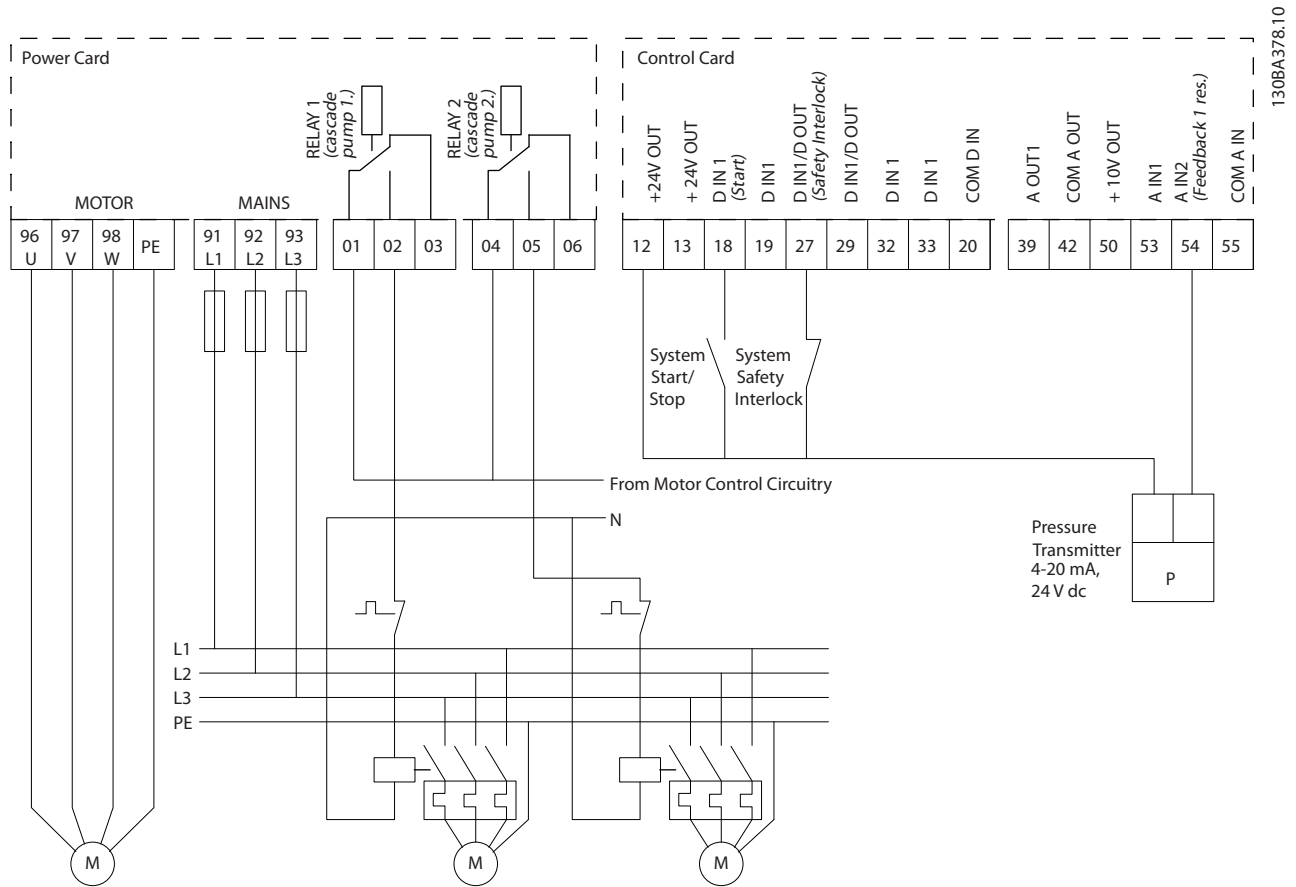

Illustration 7.11 Cascade Controller Wiring Diagram

7

### 7.1.14 Start/Stop Conditions

See 5-1\* *Digital Inputs*.

Digital input commands	Variable speed pump (lead)	Fixed speed pumps (lag)
Start (SYSTEM START/STOP)	Ramps up (if stopped and there is a demand)	Staging (if stopped and there is a demand)
Lead Pump Start	Ramps up if SYSTEM START is active	Not affected
Coast (EMERGENCY STOP)	Coast to stop	Cut out (correspond relays, terminal 27/29 and 42/45)
External Interlock	Coast to stop	Cut out (built-in relays are de-energised)

**Table 7.1 Commands Assigned to Digital Inputs**

LCP keys	Variable speed pump (lead)	Fixed speed pumps (lag)
[Hand On]	Ramps up (if stopped by a normal stop command) or stays in operation if already running	Destaging (if running)
[Off]	Ramps down	Destaging
[Auto On]	Starts and stops according to commands via terminals or serial bus cascade controller only can work when drive in "Auto ON" mode	Staging/Destaging

**Table 7.2 LCP Key Functions**

## 8 Installation and Set-up

### 8.1 Installation and Set-up

#### 8.1.1 Overview

RS-485 is a 2-wire bus interface compatible with multi-drop network topology, that is, nodes can be connected as a bus, or via drop cables from a common trunk line. A total of 32 nodes can be connected to one network segment. Repeaters divide network segments.

#### **NOTICE**

Each repeater functions as a node within the segment in which it is installed. Each node connected within a given network must have a unique node address across all segments.

Terminate each segment at both ends, using either the termination switch (S801) of the frequency converters or a biased termination resistor network. Always use screened twisted pair (STP) cable for bus cabling, and always follow good common installation practice.

Low-impedance ground connection of the screen at every node is important, including at high frequencies. Thus, connect a large surface of the screen to ground, for example with a cable clamp or a conductive cable gland. It may be necessary to apply potential-equalising cables to maintain the same earth potential throughout the network - particularly in installations with long cables.

To prevent impedance mismatch, always use the same type of cable throughout the entire network. When connecting a motor to the frequency converter, always use screened motor cable.

Cable	Screened twisted pair (STP)
Impedance [Ω]	120
Cable length [m]	Max. 1200 (including drop lines) Max. 500 station-to-station

Table 8.1 Cable Specifications

One or more frequency converters can be connected to a control (or master) using the RS-485 standardised interface. Terminal 68 is connected to the P signal (TX+, RX+), while terminal 69 is connected to the N signal (TX-,RX-). See drawings in *chapter 6.8.3 Grounding of Screened Control Cables*.

If more than one frequency converter is connected to a master, use parallel connections.

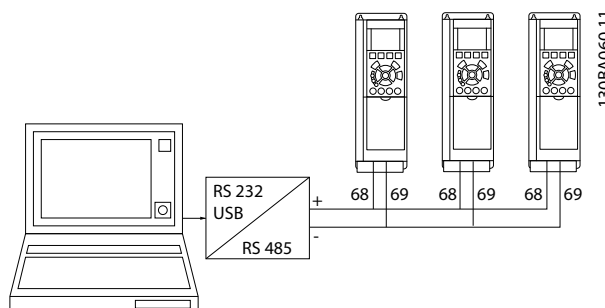

Illustration 8.1 Parallel Connections

To avoid potential equalising currents in the screen, ground the cable screen via terminal 61, which is connected to the frame via an RC-link.

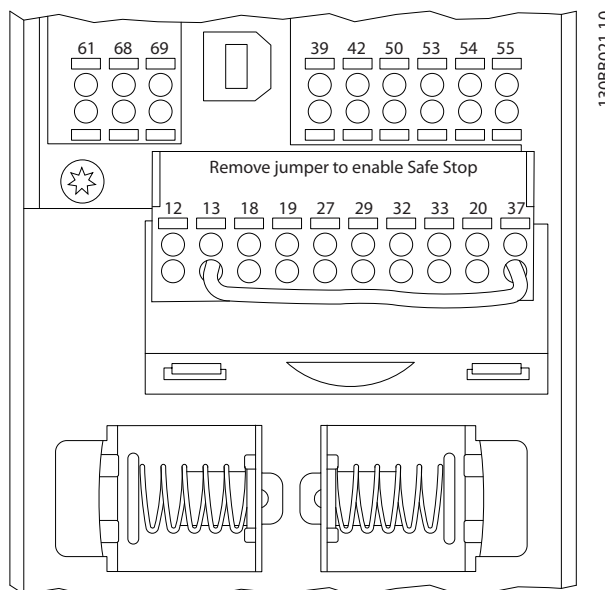

Illustration 8.2 Control Card Terminals

#### 8.1.2 Frequency Converter Hardware Setup

Use the terminator dip switch on the main control board of the frequency converter to terminate the RS-485 bus.

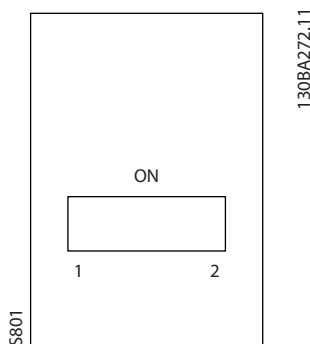

Illustration 8.3 Terminator Switch Factory Setting

The factory setting for the dip switch is OFF.

### 8.1.3 Frequency Converter Parameter Settings for Modbus Communication

The following parameters apply to the RS-485 interface (FC-port):

Parameter	Function
8-30 Protocol	Select the application protocol to run on the RS-485 interface
8-31 Address	Set the node address. Note: The address range depends on the protocol selected in <i>8-30 Protocol</i>
8-32 Baud Rate	Set the baud rate. Note: The default baud rate depends on the protocol selected in <i>8-30 Protocol</i>
8-33 Parity / Stop Bits	Set the parity and number of stop bits. Note: The default selection depends on the protocol selected in <i>8-30 Protocol</i>
8-35 Minimum Response Delay	Specify a minimum delay time between receiving a request and transmitting a response. This can be used for overcoming modem turnaround delays.
8-36 Maximum Response Delay	Specify a maximum delay time between transmitting a request and receiving a response.
8-37 Maximum Inter-Char Delay	Specify a maximum delay time between two received bytes to ensure time-out if transmission is interrupted.

Table 8.2 Parameters Apply to the RS-485 Interface (FC-port)

### 8.1.4 EMC Precautions

The following EMC precautions are recommended to achieve interference-free operation of the RS-485 network.

Observe relevant national and local regulations, for example regarding protective earth connection. Keep the RS-485 communication cable away from motor and brake resistor cables to avoid coupling of high frequency noise

from one cable to another. Normally, a distance of 200 mm (8 inches) is sufficient, but keeping the greatest possible distance between the cables is recommended, especially where cables run in parallel over long distances. When crossing is unavoidable, the RS-485 cable must cross motor and brake resistor cables at an angle of 90°.

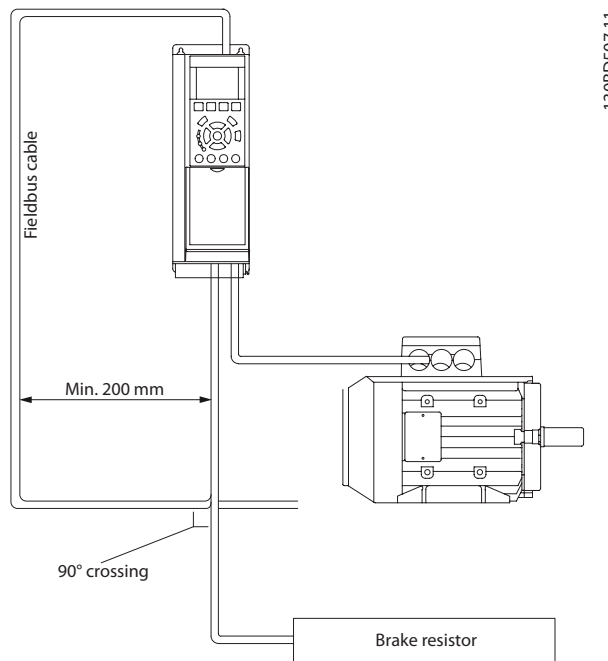

Illustration 8.4 Cable Routing

## 8.2 FC Protocol Overview

The FC protocol, also referred to as FC bus or Standard bus, is the Danfoss standard fieldbus. It defines an access technique according to the master-follower principle for communications via a serial bus.

One master and a maximum of 126 followers can be connected to the bus. The master selects the individual followers via an address character in the telegram. A follower itself can never transmit without first being requested to do so, and direct message transfer between the individual followers is not possible. Communications occur in the half-duplex mode.

The master function cannot be transferred to another node (single-master system).

The physical layer is RS-485, thus utilising the RS-485 port built into the frequency converter. The FC protocol supports different telegram formats:

- A short format of 8 bytes for process data
- A long format of 16 bytes that also includes a parameter channel
- A format used for texts

### 8.2.1 FC with Modbus RTU

The FC protocol provides access to the control word and bus reference of the frequency converter.

The control word allows the Modbus master to control several important functions of the frequency converter:

- Start
- Stop of the frequency converter in various ways:
  - Coast stop
  - Quick stop
  - DC Brake stop
  - Normal (ramp) stop
- Reset after a fault trip
- Run at a variety of preset speeds
- Run in reverse
- Change of the active set-up
- Control of the 2 relays built into the frequency converter

The bus reference is commonly used for speed control. It is also possible to access the parameters, read their values, and where possible, write values to them. This permits a range of control options, including controlling the setpoint of the frequency converter when its internal PID controller is used.

## 8.3 Network Configuration

### 8.3.1 Frequency Converter Set-up

Set the following parameters to enable the FC protocol for the frequency converter.

Parameter Number	Setting
8-30 Protocol	FC
8-31 Address	1 - 126
8-32 Baud Rate	2400 - 115200
8-33 Parity / Stop Bits	Even parity, 1 stop bit (default)

Table 8.3 Parameters Enable the FC Protocol

## 8.4 FC Protocol Message Framing Structure

### 8.4.1 Content of a Character (byte)

Each character transferred begins with a start bit. Then 8 data bits are transferred, corresponding to a byte. Each character is secured via a parity bit. This bit is set at "1" when it reaches parity. Parity is when there is an equal number of 1s in the 8 data bits and the parity bit in total. A stop bit completes a character, thus consisting of 11 bits in all.



Illustration 8.5 Content of a Character

195NA036:10

### 8.4.2 Telegram Structure

Each telegram has the following structure:

1. Start character (STX)=02 Hex
2. A byte denoting the telegram length (LGE)
3. A byte denoting the frequency converter address (ADR)

A number of data bytes (variable, depending on the type of telegram) follows.

A data control byte (BCC) completes the telegram.

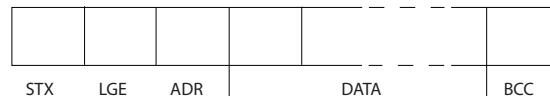

Illustration 8.6 Telegram Structure

195NA099:10

### 8.4.3 Telegram Length (LGE)

The telegram length is the number of data bytes plus the address byte ADR and the data control byte BCC.

4 data bytes	LGE=4+1+1=6 bytes
12 data bytes	LGE=12+1+1=14 bytes
Telegrams containing texts	10 <sup>1</sup> +n bytes

Table 8.4 Length of Telegrams

<sup>1)</sup> The 10 represents the fixed characters, while the "n" is variable (depending on the length of the text).

### 8.4.4 Frequency Converter Address (ADR)

2 different address formats are used.

The address range of the frequency converter is either 1-31 or 1-126.

1. Address format 1-31:

Bit 7 = 0 (address format 1-31 active)

Bit 6 is not used

Bit 5 = 1: Broadcast, address bits (0-4) are not used

Bit 5 = 0: No Broadcast

Bit 0-4 = frequency converter address 1-31

2. Address format 1-126:

- Bit 7 = 1 (address format 1-126 active)
- Bit 0-6 = frequency converter address 1-126
- Bit 0-6 = 0 Broadcast

The follower returns the address byte unchanged to the master in the response telegram.

### 8.4.5 Data Control Byte (BCC)

The checksum is calculated as an XOR-function. Before the first byte in the telegram is received, the Calculated Checksum is 0.

### 8.4.6 The Data Field

The structure of data blocks depends on the type of telegram. There are 3 telegram types, and the type applies for both control telegrams (master⇒follower) and response telegrams (follower⇒master).

The 3 types of telegram are:

#### Process block (PCD)

The PCD is made up of a data block of 4 bytes (2 words) and contains:

- Control word and reference value (from master to follower)
- Status word and present output frequency (from follower to master)



130BA269.10

Illustration 8.7 Process Block

#### Parameter block

The parameter block is used to transfer parameters between master and follower. The data block is made up of 12 bytes (6 words) and also contains the process block.

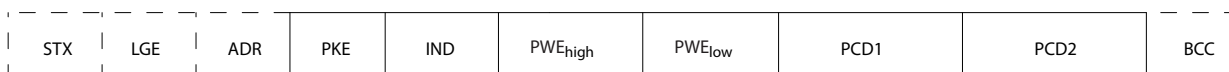

130BA271.10

Illustration 8.8 Parameter Block

#### Text block

The text block is used to read or write texts via the data block.

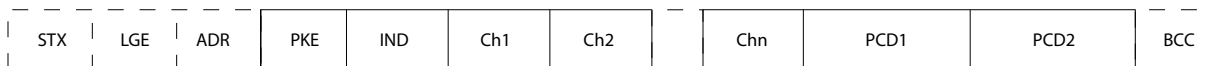

130BA270.10

Illustration 8.9 Text Block

### 8.4.7 The PKE Field

The PKE field contains 2 sub-fields: Parameter command and response AK, and Parameter number PNU:

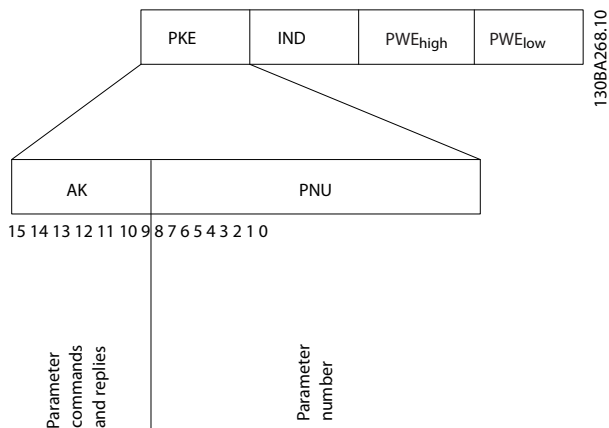

Illustration 8.10 PKE Field

Bits no. 12-15 transfer parameter commands from master to follower and return processed follower responses to the master.

Bit no.				Parameter command
15	14	13	12	
0	0	0	0	No command
0	0	0	1	Read parameter value
0	0	1	0	Write parameter value in RAM (word)
0	0	1	1	Write parameter value in RAM (double word)
1	1	0	1	Write parameter value in RAM and EEprom (double word)
1	1	1	0	Write parameter value in RAM and EEprom (word)
1	1	1	1	Read/write text

Table 8.5 Parameter Commands Master ⇒ Follower

Bit no.				Response
15	14	13	12	
0	0	0	0	No response
0	0	0	1	Parameter value transferred (word)
0	0	1	0	Parameter value transferred (double word)
0	1	1	1	Command cannot be performed
1	1	1	1	text transferred

Table 8.6 Response Follower⇒ Master

If the command cannot be performed, the follower sends this response:

0111 Command cannot be performed

- and issues the following fault report in the parameter value (PWE):

PWE low (Hex)	Fault Report
0	The parameter number used does not exist
1	There is no write access to the defined parameter
2	Data value exceeds the parameter's limits
3	The sub index used does not exist
4	The parameter is not the array type
5	The data type does not match the defined parameter
11	Data change in the defined parameter is not possible in the frequency converter's present mode. Certain parameters can only be changed when the motor is turned off
82	There is no bus access to the defined parameter
83	Data change is not possible because factory setup is selected

Table 8.7 Parameter Value Fault Report

### 8.4.8 Parameter Number (PNU)

Bits no. 0-11 transfer parameter numbers. The function of the relevant parameter is defined in the parameter description in *chapter 8.11.1 Control Word According to FC Profile (8-10 Control Profile = FC profile)*.

### 8.4.9 Index (IND)

The index is used together with the parameter number to read/write-access parameters with an index, e.g. *15-30 Alarm Log: Error Code*. The index consists of 2 bytes, a low byte and a high byte.

Only the low byte is used as an index.

### 8.4.10 Parameter Value (PWE)

The parameter value block consists of 2 words (4 bytes), and the value depends on the defined command (AK). The master prompts for a parameter value when the PWE block contains no value. To change a parameter value (write), write the new value in the PWE block and send from the master to the follower.

When a follower responds to a parameter request (read command), the present parameter value in the PWE block is transferred and returned to the master. If a parameter contains not a numerical value, but several data options, e.g. *0-01 Language* where [0] is English, and [4] is Danish, select the data value by entering the value in the PWE block. See Example - Selecting a data value. Serial



communication is only capable of reading parameters containing data type 9 (text string).

15-40 FC Type to 15-53 Power Card Serial Number contain data type 9.

For example, read the unit size and mains voltage range in 15-40 FC Type. When a text string is transferred (read), the length of the telegram is variable, and the texts are of different lengths. The telegram length is defined in the second byte of the telegram, LGE. When using text transfer the index character indicates whether it is a read or a write command.

To read a text via the PWE block, set the parameter command (AK) to 'F' Hex. The index character high-byte must be "4".

Some parameters contain text that can be written to via the serial bus. To write a text via the PWE block, set the parameter command (AK) to 'F' Hex. The index characters high-byte must be "5".

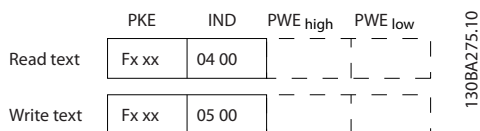

Illustration 8.11 Text via PWE Block

### 8.4.11 Data Types Supported by the Frequency Converter

Unsigned means that there is no operational sign in the telegram.

Data types	Description
3	Integer 16
4	Integer 32
5	Unsigned 8
6	Unsigned 16
7	Unsigned 32
9	Text string
10	Byte string
13	Time difference
33	Reserved
35	Bit sequence

Table 8.8 Data Types and Description

### 8.4.12 Conversion

The various attributes of each parameter are displayed in factory setting. Parameter values are transferred as whole numbers only. Conversion factors are therefore used to transfer decimals.

4-12 Motor Speed Low Limit [Hz] has a conversion factor of 0.1. To preset the minimum frequency to 10 Hz, transfer the value 100. A conversion factor of 0.1 means that the value transferred is multiplied by 0.1. The value 100 is therefore read as 10.0.

Examples:

- 0 s ⇒ conversion index 0
- 0.00 s ⇒ conversion index -2
- 0 ms ⇒ conversion index -3
- 0.00 ms ⇒ conversion index -5

Conversion index	Conversion factor
100	
75	
74	
67	
6	1000000
5	100000
4	10000
3	1000
2	100
1	10
0	1
-1	0.1
-2	0.01
-3	0.001
-4	0.0001
-5	0.00001
-6	0.000001
-7	0.0000001

Table 8.9 Conversion Table

### 8.4.13 Process Words (PCD)

The block of process words is divided into 2 blocks of 16 bits, which always occur in the defined sequence.

PCD 1	PCD 2
Control telegram (master ⇒ follower control word)	Reference-value word
Control telegram (follower ⇒ master) status word	Present output frequency

Table 8.10 Process Words (PCD)

## 8.5 Examples

### 8.5.1 Writing a Parameter Value

Change 4-14 Motor Speed High Limit [Hz] to 100 Hz. Write the data in EEPROM.

PKE = E19E Hex - Write single word in *4-14 Motor Speed High Limit [Hz]*  
 IND = 0000 Hex  
 PWEHIGH = 0000 Hex  
 PWELOW = 03E8 Hex - Data value 1000, corresponding to 100 Hz, see *chapter 8.4.12 Conversion*.

The telegram looks like this:

E19E	H	0000	H	0000	H	03E8	H
PKE		IND		PWE <sub>high</sub>		PWE <sub>low</sub>	

130BA092.10

Illustration 8.12 Write Data in EEPROM

**NOTICE**

*4-14 Motor Speed High Limit [Hz]* is a single word, and the parameter command for write in EEPROM is "E". Parameter number 4-14 is 19E in hexadecimal.

The response from the follower to the master is:

119E	H	0000	H	0000	H	03E8	H
PKE		IND		PWE <sub>high</sub>		PWE <sub>low</sub>	

130BA093.10

Illustration 8.13 Response from Follower

8.5.2 Reading a Parameter Value

Read the value in *3-41 Ramp 1 Ramp Up Time*

PKE = 1155 Hex - Read parameter value in *3-41 Ramp 1 Ramp Up Time*  
 IND = 0000 Hex  
 PWEHIGH = 0000 Hex  
 PWELOW = 0000 Hex

1155	H	0000	H	0000	H	0000	H
PKE		IND		PWE <sub>high</sub>		PWE <sub>low</sub>	

130BA094.10

Illustration 8.14 Parameter Value

If the value in *3-41 Ramp 1 Ramp Up Time* is 10 s, the response from the follower to the master is

1155	H	0000	H	0000	H	03E8	H
PKE		IND		PWE <sub>high</sub>		PWE <sub>low</sub>	

130BA267.10

Illustration 8.15 Response from Follower

3E8 Hex corresponds to 1000 decimal. The conversion index for *3-41 Ramp 1 Ramp Up Time* is -2, i.e. 0.01. *3-41 Ramp 1 Ramp Up Time* is of the type *Unsigned 32*.

8.6 Modbus RTU Overview

8.6.1 Assumptions

Danfoss assumes that the installed controller supports the interfaces in this document, and strictly observes all requirements and limitations stipulated in the controller and frequency converter.

8.6.2 What the User Should Already Know

The Modbus RTU (Remote Terminal Unit) is designed to communicate with any controller that supports the interfaces defined in this document. It is assumed that the user has full knowledge of the capabilities and limitations of the controller.

8.6.3 Modbus RTU Overview

Regardless of the type of physical communication networks, the Modbus RTU Overview describes the process a controller uses to request access to another device. This process includes how the Modbus RTU responds to requests from another device, and how errors are detected and reported. It also establishes a common format for the layout and contents of message fields.

During communications over a Modbus RTU network, the protocol determines:

- How each controller learns its device address
- Recognises a message addressed to it
- Determines which actions to take
- Extracts any data or other information contained in the message

If a reply is required, the controller constructs the reply message and sends it.

Controllers communicate using a master-follower technique in which only the master can initiate transactions (called queries). Followers respond by supplying the requested data to the master, or by taking the action requested in the query.

The master can address individual followers, or initiate a broadcast message to all followers. Followers return a response to queries that are addressed to them individually. No responses are returned to broadcast queries from the master. The Modbus RTU protocol establishes the format for the master's query by providing the device (or broadcast) address, a function code defining the requested action, any data to be sent, and an error-checking field. The follower's response message is also constructed using Modbus protocol. It contains fields confirming the action taken, any data to be returned, and

an error-checking field. If an error occurs in receipt of the message, or if the follower is unable to perform the requested action, the follower constructs an error message, and send it in response, or a time-out occurs.

### 8.6.4 Frequency Converter with Modbus RTU

The frequency converter communicates in Modbus RTU format over the built-in RS-485 interface. Modbus RTU provides access to the control word and bus reference of the frequency converter.

The control word allows the modbus master to control several important functions of the frequency converter:

- Start
- Stop of the frequency converter in various ways:
  - Coast stop
  - Quick stop
  - DC Brake stop
  - Normal (ramp) stop
- Reset after a fault trip
- Run at a variety of preset speeds
- Run in reverse
- Change the active set-up
- Control the frequency converter’s built-in relay

The bus reference is commonly used for speed control. It is also possible to access the parameters, read their values, and where possible, write values to them. This permits a range of control options, including controlling the setpoint of the frequency converter when its internal PI controller is used.

### 8.7 Network Configuration

To enable Modbus RTU on the frequency converter, set the following parameters

Parameter	Setting
8-30 Protocol	Modbus RTU
8-31 Address	1-247
8-32 Baud Rate	2400-115200
8-33 Parity / Stop Bits	Even parity, 1 stop bit (default)

Table 8.11 Modbus RTU Parameters

### 8.8 Modbus RTU Message Framing Structure

#### 8.8.1 Frequency Converter with Modbus RTU

The controllers are set up to communicate on the Modbus network using RTU (Remote Terminal Unit) mode, with each byte in a message containing 2 4-bit hexadecimal characters. The format for each byte is shown in Table 8.12.

Start bit	Data byte						Stop/parity	Stop

Table 8.12 Format for Each Byte

Coding System	8-bit binary, hexadecimal 0-9, A-F. 2 hexadecimal characters contained in each 8-bit field of the message
Bits Per Byte	1 start bit 8 data bits, least significant bit sent first 1 bit for even/odd parity; no bit for no parity 1 stop bit if parity is used; 2 bits if no parity
Error Check Field	Cyclical Redundancy Check (CRC)

#### 8.8.2 Modbus RTU Message Structure

The transmitting device places a Modbus RTU message into a frame with a known beginning and ending point. This allows receiving devices to begin at the start of the message, read the address portion, determine which device is addressed (or all devices, if the message is broadcast), and to recognise when the message is completed. Partial messages are detected and errors set as a result. Characters for transmission must be in hexadecimal 00 to FF format in each field. The frequency converter continuously monitors the network bus, also during ‘silent’ intervals. When the first field (the address field) is received, each frequency converter or device decodes it to determine which device is being addressed. Modbus RTU messages addressed to zero are broadcast messages. No response is permitted for broadcast messages. A typical message frame is shown in Table 8.13.

Start	Address	Function	Data	CRC check	End
T1-T2-T3-T4	8 bits	8 bits	N x 8 bits	16 bits	T1-T2-T3-T4

Table 8.13 Typical Modbus RTU Message Structure

### 8.8.3 Start/Stop Field

Messages start with a silent period of at least 3.5 character intervals. This is implemented as a multiple of character intervals at the selected network baud rate (shown as Start T1-T2-T3-T4). The first field to be transmitted is the device address. Following the last transmitted character, a similar period of at least 3.5 character intervals marks the end of the message. A new message can begin after this period. The entire message frame must be transmitted as a continuous stream. If a silent period of more than 1.5 character intervals occurs before completion of the frame, the receiving device flushes the incomplete message and assumes that the next byte is the address field of a new message. Similarly, if a new message begins before 3.5 character intervals after a previous message, the receiving device considers it a continuation of the previous message. This causes a time-out (no response from the follower), since the value in the final CRC field is not valid for the combined messages.

## 8

### 8.8.4 Address Field

The address field of a message frame contains 8 bits. Valid follower device addresses are in the range of 0-247 decimal. The individual follower devices are assigned addresses in the range of 1-247. (0 is reserved for broadcast mode, which all followers recognise.) A master addresses a follower by placing the follower address in the address field of the message. When the follower sends its response, it places its own address in this address field to let the master know which follower is responding.

### 8.8.5 Function Field

The function field of a message frame contains 8 bits. Valid codes are in the range of 1-FF. Function fields are used to send messages between master and follower. When a message is sent from a master to a follower device, the function code field tells the follower what kind of action to perform. When the follower responds to the master, it uses the function code field to indicate either a normal (error-free) response, or that some kind of error occurred (called an exception response). For a normal response, the follower simply echoes the original function code. For an exception response, the follower returns a code that is equivalent to the original function code with its most significant bit set to logic 1. In addition, the follower places a unique code into the data field of the response message. This tells the master what kind of error occurred, or the reason for the exception. Also refer to *chapter 8.8.10 Function Codes Supported by Modbus RTU* and *chapter 8.8.11 Modbus Exception Codes*

### 8.8.6 Data Field

The data field is constructed using sets of 2 hexadecimal digits, in the range of 00 to FF hexadecimal. These are made up of one RTU character. The data field of messages sent from a master to follower device contains additional information which the follower must use to take the action defined by the function code. This can include items such as coil or register addresses, the quantity of items to be handled, and the count of actual data bytes in the field.

### 8.8.7 CRC Check Field

Messages include an error-checking field, operating based on a Cyclical Redundancy Check (CRC) method. The CRC field checks the contents of the entire message. It is applied regardless of any parity check method used for the individual characters of the message. The CRC value is calculated by the transmitting device, which appends the CRC as the last field in the message. The receiving device recalculates a CRC during receipt of the message and compares the calculated value to the actual value received in the CRC field. If the 2 values are unequal, a bus time-out results. The error-checking field contains a 16-bit binary value implemented as 2 8-bit bytes. When this is done, the low-order byte of the field is appended first, followed by the high-order byte. The CRC high-order byte is the last byte sent in the message.

### 8.8.8 Coil Register Addressing

In Modbus, all data are organised in coils and holding registers. Coils hold a single bit, whereas holding registers hold a 2-byte word (i.e. 16 bits). All data addresses in Modbus messages are referenced to zero. The first occurrence of a data item is addressed as item number zero. For example: The coil known as 'coil 1' in a programmable controller is addressed as coil 0000 in the data address field of a Modbus message. Coil 127 decimal is addressed as coil 007EHEX (126 decimal). Holding register 40001 is addressed as register 0000 in the data address field of the message. The function code field already specifies a 'holding register' operation. Therefore, the '4XXXX' reference is implicit. Holding register 40108 is addressed as register 006BHEX (107 decimal).

Coil number	Description	Signal direction
1-16	Frequency converter control word	Master to follower
17-32	Frequency converter speed or set-point reference Range 0x0 – 0xFFFF (-200% ... ~200%)	Master to follower
33-48	Frequency converter status word (see Table 8.16)	Follower to master
49-64	Open loop mode: Frequency converter output frequency Closed loop mode: Frequency converter feedback signal	Follower to master
65	Parameter write control (master to follower)	Master to follower
	0 = Parameter changes are written to the RAM of the frequency converter	
	1 = Parameter changes are written to the RAM and EEPROM of the frequency converter.	
66-65536	Reserved	

Table 8.14 Coil Descriptions

Coil	0	1
01	Preset reference LSB	
02	Preset reference MSB	
03	DC brake	No DC brake
04	Coast stop	No coast stop
05	Quick stop	No quick stop
06	Freeze freq.	No freeze freq.
07	Ramp stop	Start
08	No reset	Reset
09	No jog	Jog
10	Ramp 1	Ramp 2
11	Data not valid	Data valid
12	Relay 1 off	Relay 1 on
13	Relay 2 off	Relay 2 on
14	Set up LSB	
15	Set up MSB	
16	No reversing	Reversing

Table 8.15 Frequency Converter Control Word (FC Profile)

Coil	0	1
33	Control not ready	Control ready
34	Frequency converter not ready	Frequency converter ready
35	Coasting stop	Safety closed
36	No alarm	Alarm
37	Not used	Not used
38	Not used	Not used
39	Not used	Not used
40	No warning	Warning
41	Not at reference	At reference
42	Hand mode	Auto mode
43	Out of freq. range	In frequency range
44	Stopped	Running
45	Not used	Not used
46	No voltage warning	Voltage warning
47	Not in current limit	Current limit
48	No thermal warning	Thermal warning

Table 8.16 Frequency Converter Status Word (FC Profile)

Register number	Description
00001-00006	Reserved
00007	Last error code from an FC data object interface
00008	Reserved
00009	Parameter index*
00010-00990	000 parameter group (parameters 001 through 099)
01000-01990	100 parameter group (parameters 100 through 199)
02000-02990	200 parameter group (parameters 200 through 299)
03000-03990	300 parameter group (parameters 300 through 399)
04000-04990	400 parameter group (parameters 400 through 499)
...	...
49000-49990	4900 parameter group (parameters 4900 through 4999)
50000	Input data: Frequency converter control word register (CTW).
50010	Input data: Bus reference register (REF).
...	...
50200	Output data: Frequency converter status word register (STW).
50210	Output data: Frequency converter main actual value register (MAV).

Table 8.17 Holding Registers

\* Used to specify the index number to be used when accessing an indexed parameter.

### 8.8.9 How to Control the Frequency Converter

This section describes codes which can be used in the function and data fields of a Modbus RTU message.

### 8.8.10 Function Codes Supported by Modbus RTU

Modbus RTU supports use of the following function codes in the function field of a message.

Function	Function code
Read coils	1 Hex
Read holding registers	3 Hex
Write single coil	5 Hex
Write single register	6 Hex
Write multiple coils	F Hex
Write multiple registers	10 Hex
Get comm. event counter	B Hex
Report follower ID	11 Hex

Table 8.18 Function Codes

Function	Function Code	Sub-function code	Sub-function
Diagnostics	8	1	Restart communication
		2	Return diagnostic register
		10	Clear counters and diagnostic register
		11	Return bus message count
		12	Return bus communication error count
		13	Return bus exception error count
		14	Return follower message count

Table 8.19 Function Codes

### 8.8.11 Modbus Exception Codes

For a full explanation of the structure of an exception code response, refer to *chapter 8.8.5 Function Field*.

Code	Name	Meaning
1	Illegal function	The function code received in the query is not an allowable action for the server (or follower). This may be because the function code is only applicable to newer devices, and was not implemented in the unit selected. It could also indicate that the server (or follower) is in the wrong state to process a request of this type, for example because it is not configured and is being asked to return register values.
2	Illegal data address	The data address received in the query is not an allowable address for the server (or follower). More specifically, the combination of reference number and transfer length is invalid. For a controller with 100 registers, a request with offset 96 and length 4 would succeed, a request with offset 96 and length 5 generates exception 02.
3	Illegal data value	A value contained in the query data field is not an allowable value for server (or follower). This indicates a fault in the structure of the remainder of a complex request, such as that the implied length is incorrect. It specifically does NOT mean that a data item submitted for storage in a register has a value outside the expectation of the application program, since the Modbus protocol is unaware of the significance of any particular value of any particular register.
4	Follower device failure	An unrecoverable error occurred while the server (or follower) was attempting to perform the requested action.

Table 8.20 Modbus Exception Codes

## 8.9 How to Access Parameters

### 8.9.1 Parameter Handling

The PNU (Parameter Number) is translated from the register address contained in the Modbus read or write message. The parameter number is translated to Modbus as (10 x parameter number) DECIMAL. Example: Reading 3-12 *Catch up/slow Down Value* (16bit): The holding register 3120 holds the parameters value. A value of 1352 (Decimal), means that the parameter is set to 12.52%

Reading 3-14 *Preset Relative Reference* (32bit): The holding registers 3410 & 3411 holds the parameters value. A value of 11300 (Decimal), means that the parameter is set to 1113.00 S.

For information on the parameters, size and converting index, consult the product relevant programming guide.

## 8.9.2 Storage of Data

The Coil 65 decimal determines whether data written to the frequency converter are stored in EEPROM and RAM (coil 65=1) or only in RAM (coil 65= 0).

## 8.9.3 IND

Some parameters in the frequency converter are array parameters e.g. *3-10 Preset Reference*. Since the Modbus does not support arrays in the holding registers, the frequency converter has reserved the holding register 9 as pointer to the array. Before reading or writing an array parameter, set the holding register 9. Setting holding register to the value of 2, causes all following read/write to array parameters to be to the index 2.

## 8.9.4 Text Blocks

Parameters stored as text strings are accessed in the same way as the other parameters. The maximum text block size is 20 characters. If a read request for a parameter is for more characters than the parameter stores, the response is truncated. If the read request for a parameter is for fewer characters than the parameter stores, the response is space filled.

## 8.9.5 Conversion Factor

The different attributes for each parameter can be seen in the section on factory settings. Since a parameter value can only be transferred as a whole number, a conversion factor must be used to transfer decimals.

## 8.9.6 Parameter Values

### Standard data types

Standard data types are int 16, int 32, uint 8, uint 16 and uint 32. They are stored as 4x registers (40001–4FFFF). The parameters are read using function 03HEX "Read Holding Registers." Parameters are written using the function 6HEX "Preset Single Register" for 1 register (16 bits), and the function 10 HEX "Preset Multiple Registers" for 2 registers (32 bits). Readable sizes range from 1 register (16 bits) up to 10 registers (20 characters).

### Non-standard data types

Non-standard data types are text strings and are stored as 4x registers (40001–4FFFF). The parameters are read using function 03HEX "Read Holding Registers" and written using function 10HEX "Preset Multiple Registers." Readable sizes range from 1 register (2 characters) up to 10 registers (20 characters).

## 8.10 Examples

The following examples illustrate various Modbus RTU commands.

### 8.10.1 Read Coil Status (01 HEX)

#### Description

This function reads the ON/OFF status of discrete outputs (coils) in the frequency converter. Broadcast is never supported for reads.

#### Query

The query message specifies the starting coil and quantity of coils to be read. Coil addresses start at zero, that is, coil 33 is addressed as 32.

Example of a request to read coils 33-48 (status word) from follower device 01.

Field Name	Example (HEX)
Follower Address	01 (frequency converter address)
Function	01 (read coils)
Starting Address HI	00
Starting Address LO	20 (32 decimals) Coil 33
No. of Points HI	00
No. of Points LO	10 (16 decimals)
Error Check (CRC)	-

Table 8.21 Query

#### Response

The coil status in the response message is packed as one coil per bit of the data field. Status is indicated as: 1=ON; 0=OFF. The LSB of the first data byte contains the coil addressed in the query. The other coils follow toward the high order end of this byte, and from 'low-order to high-order' in subsequent bytes.

If the returned coil quantity is not a multiple of 8, the remaining bits in the final data byte is padded with zeros (toward the high order end of the byte). The byte count field specifies the number of complete bytes of data.

Field Name	Example (HEX)
Follower Address	01 (frequency converter address)
Function	01 (read coils)
Byte Count	02 (2 bytes of data)
Data (Coils 40-33)	07
Data (Coils 48-41)	06 (STW=0607hex)
Error Check (CRC)	-

Table 8.22 Response

**NOTICE**

Coils and registers are addressed explicitly with an offset of -1 in Modbus.

i.e. Coil 33 is addressed as Coil 32.

### 8.10.2 Force/Write Single Coil (05 HEX)

#### Description

This function forces the coil to either ON or OFF. When broadcast, the function forces the same coil references in all attached followers.

#### Query

The query message specifies the coil 65 (parameter write control) to be forced. Coil addresses start at zero, that is, coil 65 is addressed as 64. Force Data=00 00HEX (OFF) or FF 00HEX (ON).

Field Name	Example (HEX)
Follower Address	01 (Frequency converter address)
Function	05 (write single coil)
Coil Address HI	00
Coil Address LO	40 (64 decimal) Coil 65
Force Data HI	FF
Force Data LO	00 (FF 00=ON)
Error Check (CRC)	-

Table 8.23 Query

#### Response

The normal response is an echo of the query, returned after the coil state has been forced.

Field Name	Example (HEX)
Follower Address	01
Function	05
Force Data HI	FF
Force Data LO	00
Quantity of Coils HI	00
Quantity of Coils LO	01
Error Check (CRC)	-

Table 8.24 Response

### 8.10.3 Force/Write Multiple Coils (0F HEX)

#### Description

This function forces each coil in a sequence of coils to either ON or OFF. When broadcasting the function forces the same coil references in all attached followers.

#### Query

The query message specifies the coils 17 to 32 (speed set-point) to be forced.

Field Name	Example (HEX)
Follower Address	01 (frequency converter address)
Function	0F (write multiple coils)
Coil Address HI	00
Coil Address LO	10 (coil address 17)
Quantity of Coils HI	00
Quantity of Coils LO	10 (16 coils)
Byte Count	02
Force Data HI (Coils 8-1)	20
Force Data LO (Coils 16-9)	00 (ref.=2000 hex)
Error Check (CRC)	-

Table 8.25 Query

#### Response

The normal response returns the follower address, function code, starting address, and quantity of coils forced.

Field Name	Example (HEX)
Follower Address	01 (frequency converter address)
Function	0F (write multiple coils)
Coil Address HI	00
Coil Address LO	10 (coil address 17)
Quantity of Coils HI	00
Quantity of Coils LO	10 (16 coils)
Error Check (CRC)	-

Table 8.26 Response

### 8.10.4 Read Holding Registers (03 HEX)

#### Description

This function reads the contents of holding registers in the following.

#### Query

The query message specifies the starting register and quantity of registers to be read. Register addresses start at zero, i.e. registers 1-4 are addressed as 0-3.

Field Name	Example (HEX)
Slave Address	01
Function	03 (read holding registers)
Starting Address HI	0B (Register address 3029)
Starting Address LO	D5 (Register address 3029)
No. of Points HI	00
No. of Points LO	02 - (Par. 3-03 is 32 bits long, i.e. 2 registers)
Error Check (CRC)	-

Table 8.27 Example: Read 3-03 Maximum Reference, register 03030



**Response**

The register data in the response message are packed as 2 bytes per register, with the binary contents right justified within each byte. For each register, the first byte contains the high-order bits and the second contains the low-order bits.

Field Name	Example (HEX)
Slave Address	01
Function	03
Byte Count	04
Data HI (Register 3030)	00
Data LO (Register 3030)	16
Data HI (Register 3031)	E3
Data LO (Register 3031)	60
Error Check (CRC)	-

Table 8.28 Example: Hex 0016E360=1.500.000=1500 RPM

### 8.10.5 Preset Single Register (06 HEX)

**Description**

This function presets a value into a single holding register.

**Query**

The query message specifies the register reference to be preset. Register addresses start at zero, that is, register 1 is addressed as 0.

Example: Write to *1-00 Configuration Mode*, register 1000.

Field Name	Example (HEX)
Follower Address	01
Function	06
Register Address HI	03 (Register address 999)
Register Address LO	E7 (Register address 999)
Preset Data HI	00
Preset Data LO	01
Error Check (CRC)	-

Table 8.29 Query

**Response**

The normal response is an echo of the query, returned after the register contents have been passed.

Field Name	Example (HEX)
Follower Address	01
Function	06
Register Address HI	03
Register Address LO	E7
Preset Data HI	00
Preset Data LO	01
Error Check (CRC)	-

Table 8.30 Response

### 8.10.6 Preset Multiple Registers (10 HEX)

**Description**

This function presets values into a sequence of holding registers.

**Query**

The query message specifies the register references to be preset. Register addresses start at zero, i.e. register 1 is addressed as 0. Example of a request to preset 2 registers (set parameter 1-24=738 (7.38 A))

Field Name	Example (HEX)
Slave Address	01
Function	10
Starting Address HI	04
Starting Address LO	D7
No. of Registers HI	00
No. of registers LO	02
Byte Count	04
Write Data HI (Register 4: 1049)	00
Write Data LO (Register 4: 1049)	00
Write Data HI (Register 4: 1050)	02
Write Data LO (Register 4: 1050)	E2
Error Check (CRC)	-

Table 8.31 Query

**Response**

The normal response returns the slave address, function code, starting address, and quantity of registers preset.

Field Name	Example (HEX)
Slave Address	01
Function	10
Starting Address HI	04
Starting Address LO	D7
No. of Registers HI	00
No. of registers LO	02
Error Check (CRC)	-

Table 8.32 Response

8.11 Danfoss FC Control Profile

8.11.1 Control Word According to FC Profile (8-10 Control Profile = FC profile)

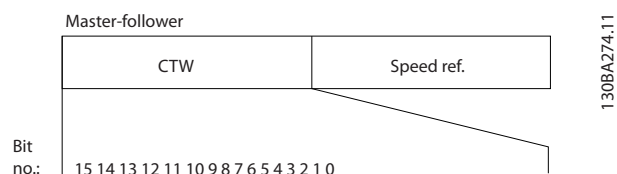

Illustration 8.16 Control Word

Bit	Bit value = 0	Bit value = 1
00	Reference value	External selection lsb
01	Reference value	External selection msb
02	DC brake	Ramp
03	Coasting	No coasting
04	Quick stop	Ramp
05	Hold output frequency	Use ramp
06	Ramp stop	Start
07	No function	Reset
08	No function	Jog
09	Ramp 1	Ramp 2
10	Data invalid	Data valid
11	No function	Relay 01 active
12	No function	Relay 02 active
13	Parameter set-up	Selection lsb
14	Parameter set-up	Selection msb
15	No function	Reverse

Table 8.33 Control Word Bits

**Explanation of the Control Bits**

**Bits 00/01**

Bits 00 and 01 are used to select between the 4 reference values, which are pre-programmed in 3-10 Preset Reference according to Table 8.34.

Programmed ref. value	Parameter	Bit 01	Bit 00
1	3-10 Preset Reference [0]	0	0
2	3-10 Preset Reference [1]	0	1
3	3-10 Preset Reference [2]	1	0
4	3-10 Preset Reference [3]	1	1

Table 8.34 Reference Values

**NOTICE**

Make a selection in 8-56 Preset Reference Select to define how Bit 00/01 gates with the corresponding function on the digital inputs.

**Bit 02, DC brake**

Bit 02 = '0' leads to DC braking and stop. Set braking current and duration in 2-01 DC Brake Current and 2-02 DC Braking Time. Bit 02 = '1' leads to ramping.

**Bit 03, Coasting**

Bit 03 = '0': The frequency converter immediately "lets go" of the motor, (the output transistors are "shut off") and it coasts to a standstill. Bit 03 = '1': The frequency converter starts the motor, if the other starting conditions are met.

Make a selection in 8-50 Coasting Select to define how Bit 03 gates with the corresponding function on a digital input.

**Bit 04, Quick stop**

Bit 04 = '0': Makes the motor speed ramp down to stop (set in 3-81 Quick Stop Ramp Time).

**Bit 05, Hold output frequency**

Bit 05 = '0': The present output frequency (in Hz) freezes. Change the frozen output frequency only with the digital inputs (5-10 Terminal 18 Digital Input to 5-15 Terminal 33 Digital Input) programmed to Speed up and Slow down.

**NOTICE**

If Freeze output is active, the frequency converter can only be stopped by the following:

- Bit 03 Coasting stop
- Bit 02 DC braking
- Digital input (5-10 Terminal 18 Digital Input to 5-15 Terminal 33 Digital Input) programmed to DC braking, Coasting stop, or Reset and coasting stop.

**Bit 06, Ramp stop/start**

Bit 06 = '0': Causes a stop and makes the motor speed ramp down to stop via the selected ramp down parameter. Bit 06 = '1': Permits the frequency converter to start the motor, if the other starting conditions are met.

Make a selection in 8-53 *Start Select* to define how Bit 06 Ramp stop/start gates with the corresponding function on a digital input.

**Bit 07, Reset**

Bit 07 = '0': No reset. Bit 07 = '1': Resets a trip. Reset is activated on the signal's leading edge, i.e. when changing from logic '0' to logic '1'.

**Bit 08, Jog**

Bit 08 = '1': The output frequency is determined by 3-19 *Jog Speed [RPM]*.

**Bit 09, Selection of ramp 1/2**

Bit 09 = "0": Ramp 1 is active (3-41 *Ramp 1 Ramp Up Time* to 3-42 *Ramp 1 Ramp Down Time*). Bit 09 = "1": Ramp 2 (3-51 *Ramp 2 Ramp Up Time* to 3-52 *Ramp 2 Ramp Down Time*) is active.

**Bit 10, Data not valid/Data valid**

Tell the frequency converter whether to use or ignore the control word. Bit 10 = '0': The control word is ignored. Bit 10 = '1': The control word is used. This function is relevant because the telegram always contains the control word, regardless of the telegram type. Turn off the control word, if it should not be used when updating or reading parameters.

**Bit 11, Relay 01**

Bit 11 = "0": Relay not activated. Bit 11 = "1": Relay 01 activated provided that *Control word bit 11* is selected in 5-40 *Function Relay*.

**Bit 12, Relay 04**

Bit 12 = "0": Relay 04 is not activated. Bit 12 = "1": Relay 04 is activated provided that *Control word bit 12* is selected in 5-40 *Function Relay*.

**Bit 13/14, Selection of set-up**

Use bits 13 and 14 to select from the 4 menu set-ups according to *Table 8.35*.

Set-up	Bit 14	Bit 13
1	0	0
2	0	1
3	1	0
4	1	1

**Table 8.35 4 Menu Set-ups**

The function is only possible when *Multi Set-Ups* is selected in 0-10 *Active Set-up*.

Make a selection in 8-55 *Set-up Select* to define how Bit 13/14 gates with the corresponding function on the digital inputs.

**Bit 15 Reverse**

Bit 15 = '0': No reversing. Bit 15 = '1': Reversing. In the default setting, reversing is set to digital in 8-54 *Reversing Select*. Bit 15 causes reversing only when Ser. communication, Logic or or Logic and is selected.

**8.11.2 Status Word According to FC Profile (STW) (8-10 Control Profile = FC profile)**

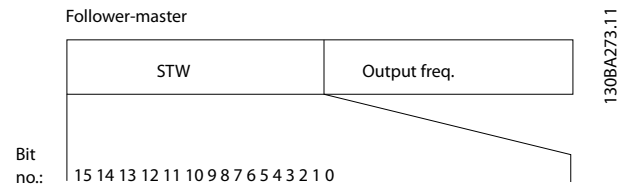

**Illustration 8.17 Status Word**

Bit	Bit = 0	Bit = 1
00	Control not ready	Control ready
01	Drive not ready	Drive ready
02	Coasting	Enable
03	No error	Trip
04	No error	Error (no trip)
05	Reserved	-
06	No error	Triplock
07	No warning	Warning
08	Speed ≠ reference	Speed = reference
09	Local operation	Bus control
10	Out of frequency limit	Frequency limit OK
11	No operation	In operation
12	Drive OK	Stopped, auto start
13	Voltage OK	Voltage exceeded
14	Torque OK	Torque exceeded
15	Timer OK	Timer exceeded

**Table 8.36 Status Word Bits**

**Explanation of the Status Bits**

**Bit 00, Control not ready/ready**

Bit 00 = '0': The frequency converter trips. Bit 00 = '1': The frequency converter controls are ready but the power component does not necessarily receive any power supply (in case of external 24 V supply to controls).

**Bit 01, Drive ready**

Bit 01 = '1': The frequency converter is ready for operation but the coasting command is active via the digital inputs or via serial communication.

**Bit 02, Coasting stop**

Bit 02 = '0': The frequency converter releases the motor. Bit 02 = '1': The frequency converter starts the motor with a start command.

**Bit 03, No error/trip**

Bit 03 = '0': The frequency converter is not in fault mode. Bit 03 = '1': The frequency converter trips. To re-establish operation, enter [Reset].

**Bit 04, No error/error (no trip)**

Bit 04 = '0': The frequency converter is not in fault mode.  
 Bit 04 = "1": The frequency converter shows an error but does not trip.

**Bit 05, Not used**

Bit 05 is not used in the status word.

**Bit 06, No error/triplock**

Bit 06 = '0': The frequency converter is not in fault mode.  
 Bit 06 = "1": The frequency converter is tripped and locked.

**Bit 07, No warning/warning**

Bit 07 = '0': There are no warnings. Bit 07 = '1': A warning has occurred.

**Bit 08, Speed ≠ reference/speed = reference**

Bit 08 = '0': The motor is running, but the present speed is different from the preset speed reference. It might e.g. be the case when the speed ramps up/down during start/stop. Bit 08 = '1': The motor speed matches the preset speed reference.

**Bit 09, Local operation/bus control**

Bit 09 = '0': [STOP/RESET] is activated on the control unit or *Local control* in 3-13 *Reference Site* is selected. Control via serial communication is not possible. Bit 09 = '1' It is possible to control the frequency converter via the fieldbus/serial communication.

**Bit 10, Out of frequency limit**

Bit 10 = '0': The output frequency has reached the value in 4-11 *Motor Speed Low Limit [RPM]* or 4-13 *Motor Speed High Limit [RPM]*. Bit 10 = "1": The output frequency is within the defined limits.

**Bit 11, No operation/in operation**

Bit 11 = '0': The motor is not running. Bit 11 = '1': The frequency converter has a start signal or the output frequency is greater than 0 Hz.

**Bit 12, Drive OK/stopped, autostart**

Bit 12 = '0': There is no temporary overtemperature on the inverter. Bit 12 = '1': The inverter stops because of overtemperature, but the unit does not trip and resumes operation once the overtemperature stops.

**Bit 13, Voltage OK/limit exceeded**

Bit 13 = '0': There are no voltage warnings. Bit 13 = '1': The DC-voltage in the frequency converter's intermediate circuit is too low or too high.

**Bit 14, Torque OK/limit exceeded**

Bit 14 = '0': The motor current is lower than the torque limit selected in 4-18 *Current Limit*. Bit 14 = '1': The torque limit in 4-18 *Current Limit* is exceeded.

**Bit 15, Timer OK/limit exceeded**

Bit 15 = '0': The timers for motor thermal protection and thermal protection are not exceeded 100%. Bit 15 = '1': One of the timers exceeds 100%.

All bits in the STW are set to '0' if the connection between the Interbus option and the frequency converter is lost, or an internal communication problem has occurred.

**8.11.3 Bus Speed Reference Value**

Speed reference value is transmitted to the frequency converter in a relative value in %. The value is transmitted in the form of a 16-bit word; in integers (0-32767) the value 16384 (4000 Hex) corresponds to 100%. Negative figures are formatted by means of 2's complement. The Actual Output frequency (MAV) is scaled in the same way as the bus reference.

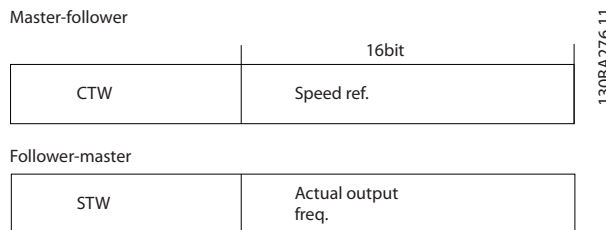

**Illustration 8.18 Actual Output Frequency (MAV)**

The reference and MAV are scaled as follows:

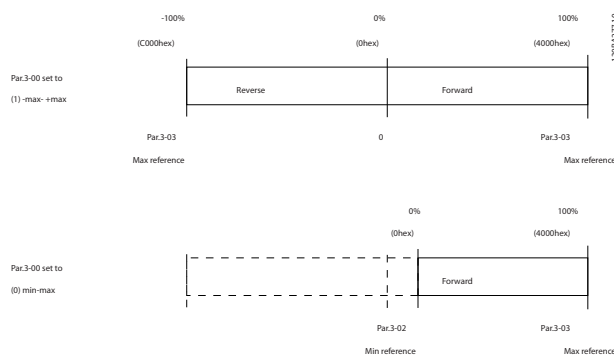

**Illustration 8.19 Reference and MAV**

## 9 General Specifications and Troubleshooting

### 9.1 Mains Supply Tables

Mains supply 3x200-240 V AC - Normal overload 110% for 1 minute						
Frequency Converter		P1K1	P1K5	P2K2	P3K0	P3K7
Typical Shaft Output [kW]		1.1	1.5	2.2	3	3.7
IP20/Chassis (A2+A3 may be converted to IP21 using a conversion kit)		A2	A2	A2	A3	A3
IP55/NEMA 12		A4/A5	A4/A5	A4/A5	A5	A5
IP66/NEMA 12		A5	A5	A5	A5	A5
Typical Shaft Output [hp] at 208 V		1.5	2.0	2.9	4.0	4.9
<b>Output current</b>						
 130BA058.10	Continuous (3x200-240 V) [A]	6.6	7.5	10.6	12.5	16.7
	Intermittent (3x200-240 V) [A]	7.3	8.3	11.7	13.8	18.4
	Continuous kVA (208 V AC) [kVA]	2.38	2.70	3.82	4.50	6.00
	Max. cable size:					
	(mains, motor, brake) [mm <sup>2</sup> /AWG] <sup>2</sup>		4/10			
<b>Max. input current</b>						
 130BA057.10	Continuous (3x200-240 V) [A]	5.9	6.8	9.5	11.3	15.0
	Intermittent (3x200-240 V) [A]	6.5	7.5	10.5	12.4	16.5
	Max. pre-fuses <sup>1)</sup> [A]	20	20	20	32	32
	<b>Environment</b>					
	Estimated power loss at rated max. load [W] <sup>4)</sup>	63	82	116	155	185
	Weight enclosure IP20 [kg]	4.9	4.9	4.9	6.6	6.6
	Weight enclosure IP21 [kg]	5.5	5.5	5.5	7.5	7.5
	Weight enclosure IP55 [kg]	9.7/13.5	9.7/13.5	9.7/13.5	13.5	13.5
	Weight enclosure IP66 [kg]	9.7/13.5	9.7/13.5	9.7/13.5	13.5	13.5
	Efficiency <sup>3)</sup>	0.96	0.96	0.96	0.96	0.96

Table 9.1 Mains Supply 3x200-240 V AC

Mains supply 3x200-240 V AC - Normal overload 110% for 1 minute										
IP20/Chassis	B3	B3	B3	B4	B4	B3	B3	B3	C3	C4
(B3+4 and C3+4 may be converted to IP21 using a conversion kit)										
IP21/NEMA 1	B1	B1	B1	B2	B2	B1	B1	B1	C1	C2
IP55/NEMA 12	B1	B1	B1	B2	B2	B1	B1	B1	C1	C2
IP66/NEMA 12	B1	B1	B1	B2	B2	B1	B1	B1	C1	C2
Typical Shaft Output [kW]	P5K5 5.5	P7K5 7.5	P11K 11	P15K 15	P18K 18.5	P22K 22	P30K 30	P37K 37	P45K 45	
Typical Shaft Output [hp] at 208 V	7.5	10	15	20	25	30	40	50	60	
Output current										
Continuous (3x200-240 V) [A]	24.2	30.8	46.2	59.4	74.8	88.0	115	143	170	
	16/6			35/2		35/2		70/3/0	185/ kcmil350	
Continuous (3x200-240 V) [A]	22.0	28.0	42.0	54.0	68.0	80.0	104.0	130.0	154.0	
Intermittent (3x200-240 V) [A]	24.2	30.8	46.2	59.4	74.8	88.0	114.0	143.0	169.0	
Max. pre-fuses <sup>1)</sup> [A]	63	63	63	80	125	125	160	200	250	
Environment:										
Estimated power loss at rated max. load [W] <sup>4)</sup>	269	310	447	602	737	845	1140	1353	1636	
Weight enclosure IP20 [kg]	12	12	12	23.5	23.5	35	35	50	50	
Weight enclosure IP21 [kg]	23	23	23	27	45	45	45	65	65	
Weight enclosure IP55 [kg]	23	23	23	27	45	45	45	65	65	
Weight enclosure IP66 [kg]	23	23	23	27	45	45	45	65	65	
Efficiency <sup>3)</sup>	0.96	0.96	0.96	0.96	0.96	0.97	0.97	0.97	0.97	
Intermittent (3x200-240 V) [A]	26.6	33.9	50.8	65.3	82.3	96.8	127	157	187	
Continuous kVA (208 V AC) [kVA]	8.7	11.1	16.6	21.4	26.9	31.7	41.4	51.5	61.2	
Max. cable size: (mains, motor, brake) [mm <sup>2</sup> /AWG] <sup>2)</sup>		10/7		35/2		50/1/0 (B4=35/2)		95/4/0	120/250 MCM	

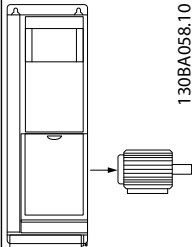
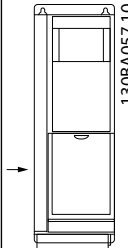
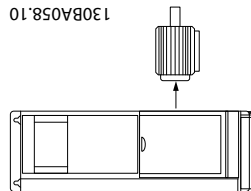

Table 9.2 Mains Supply 3x200-240 V AC

Mains Supply 3x380-480 V AC - Normal overload 110% for 1 minute									
Frequency converter	P1K1	P1K5	P2K2	P3K0	P4K0	P5K5	P7K5		
Typical Shaft Output [kW]	1.1	1.5	2.2	3	4	5.5	7.5		
Typical Shaft Output [hp] at 460 V	1.5	2.0	2.9	4.0	5.0	7.5	10		
IP20/Chassis (A2+A3 may be converted to IP21 using a conversion kit)	A2	A2	A2	A2	A2	A3	A3		
IP55/NEMA 12	A4/A5	A4/A5	A4/A5	A4/A5	A4/A5	A5	A5		
IP66/NEMA 12	A4/A5	A4/A5	A4/A5	A4/A5	A4/A5	A5	A5		
Output current									
 130BA058.10	Continuous (3x380-440V) [A]	3	4.1	5.6	7.2	10	13	16	
	Intermittent (3x380-440V) [A]	3.3	4.5	6.2	7.9	11	14.3	17.6	
	Continuous (3x441-480V) [A]	2.7	3.4	4.8	6.3	8.2	11	14.5	
	Intermittent (3x441-480V) [A]	3.0	3.7	5.3	6.9	9.0	12.1	15.4	
	Continuous kVA (400 V AC) [kVA]	2.1	2.8	3.9	5.0	6.9	9.0	11.0	
	Continuous kVA (460 V AC) [kVA]	2.4	2.7	3.8	5.0	6.5	8.8	11.6	
	Max. cable size: (mains, motor, brake) [[mm <sup>2</sup> /AWG] <sup>2)</sup>	4/10							
	Max. input current								
 130BA057.10	Continuous (3x380-440 V) [A]	2.7	3.7	5.0	6.5	9.0	11.7	14.4	
	Intermittent (3x380-440 V) [A]	3.0	4.1	5.5	7.2	9.9	12.9	15.8	
	Continuous (3x441-480 V) [A]	2.7	3.1	4.3	5.7	7.4	9.9	13.0	
	Intermittent (3x441-480 V) [A]	3.0	3.4	4.7	6.3	8.1	10.9	14.3	
	Max. pre-fuses <sup>1)</sup> [A]	10	10	20	20	20	32	32	
	Environment								
	Estimated power loss at rated max. load [W] <sup>4)</sup>	58	62	88	116	124	187	255	
	Weight enclosure IP20 [kg]	4.8	4.9	4.9	4.9	4.9	6.6	6.6	
	Weight enclosure IP21 [kg]								
	Weight enclosure IP55 [kg]	9.7/13.5	9.7/13.5	9.7/13.5	9.7/13.5	9.7/13.5	14.2	14.2	
	Weight enclosure IP66 [kg]	9.7/13.5	9.7/13.5	9.7/13.5	9.7/13.5	9.7/13.5	14.2	14.2	
Efficiency <sup>3)</sup>	0.96	0.97	0.97	0.97	0.97	0.97	0.97		

Table 9.3 Mains Supply 3x380-480 V AC

Mains Supply 3x380-480 V AC - Normal overload 110% for 1 minute											
Frequency converter	P11K	P15K	P18K	P22K	P30K	P37K	P45K	P55K	P75K	P90K	
Typical Shaft Output [kW]	11	15	18.5	22	30	37	45	55	75	90	
Typical Shaft Output [hp] at 460 V	15	20	25	30	40	50	60	75	100	125	
IP20/Chassis (B3+4 and C3+4 may be converted to IP21 using a conversion kit (Contact Danfoss))	B3	B3	B3	B4	B4	B4	C3	C3	C4	C4	
IP21/NEMA 1	B1	B1	B1	B2	B2	C1	C1	C1	C2	C2	
IP55/NEMA 12	B1	B1	B1	B2	B2	C1	C1	C1	C2	C2	
IP66/NEMA 12	B1	B1	B1	B2	B2	C1	C1	C1	C2	C2	
Output current											
 130BA058.10	Continuous (3x380-439 V) [A]	24	32	37.5	44	61	73	90	106	147	177
	Intermittent (3x380-439 V) [A]	26.4	35.2	41.3	48.4	67.1	80.3	99	117	162	195
	Continuous (3x440-480 V) [A]	21	27	34	40	52	65	80	105	130	160
	Intermittent (3x440-480 V) [A]	23.1	29.7	37.4	44	61.6	71.5	88	116	143	176
	Continuous kVA (400 V AC) [kVA]	16.6	22.2	26	30.5	42.3	50.6	62.4	73.4	102	123
	Continuous kVA 460 V AC) [kVA]	16.7	21.5	27.1	31.9	41.4	51.8	63.7	83.7	104	128
	Max. cable size:										
	(mains, motor, brake) [mm <sup>2</sup> /AWG] <sup>2)</sup>	10/7			35/2			50/1/0 (B4=35/2)		95/4/0	120/MCM2 50
	With mains disconnect switch included:	16/6					35/2	35/2	70/3/0	185/kcmil3 50	
	Max. input current										
 130BA057.10	Continuous (3x380-439 V) [A]	22	29	34	40	55	66	82	96	133	161
	Intermittent (3x380-439 V) [A]	24.2	31.9	37.4	44	60.5	72.6	90.2	106	146	177
	Continuous (3x440-480 V) [A]	19	25	31	36	47	59	73	95	118	145
	Intermittent (3x440-480 V) [A]	20.9	27.5	34.1	39.6	51.7	64.9	80.3	105	130	160
	Max. pre-fuses <sup>1)</sup> [A]	63	63	63	63	80	100	125	160	250	250
	Environment										
	Estimated power loss at rated max. load [W] <sup>4)</sup>	278	392	465	525	698	739	843	1083	1384	1474
	Weight enclosure IP20 [kg]	12	12	12	23.5	23.5	23.5	35	35	50	50
	Weight enclosure IP21 [kg]	23	23	23	27	27	45	45	45	65	65
	Weight enclosure IP55 [kg]	23	23	23	27	27	45	45	45	65	65
Weight enclosure IP66 [kg]	23	23	23	27	27	45	45	45	65	65	
Efficiency <sup>3)</sup>	0.98	0.98	0.98	0.98	0.98	0.98	0.98	0.98	0.98	0.99	

Table 9.4 Mains Supply 3x380-480 V AC

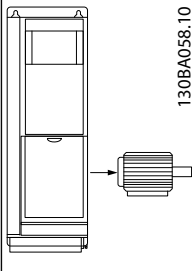
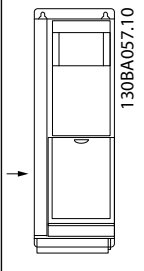

Mains supply 3x525 - 600 VAC Normal overload 110% for 1 minute																		
Size:	P1K1	P1K5	P2K2	P3K0	P3K	P4K0	P5K5	P7K5	P11K	P15K	P18K	P22K	P30K	P37K	P45K	P55K	P75K	P90K
Typical Shaft Output [kW]	1.1	1.5	2.2	3	3.7	4	5.5	7.5	11	15	18.5	22	30	37	45	55	75	90
IP20 / Chassis	A3	A3	A3	A3	A2	A3	A3	A3	B3	B3	B3	B4	B4	B4	C3	C3	C4	C4
IP21 / NEMA 1	A3	A3	A3	A3	A2	A3	A3	A3	B1	B1	B1	B2	B2	C1	C1	C1	C2	C2
IP55 / NEMA 12	A5	A5	A5	A5	A5	A5	A5	A5	B1	B1	B1	B2	B2	C1	C1	C1	C2	C2
IP66 / NEMA 12	A5	A5	A5	A5	A5	A5	A5	A5	B1	B1	B1	B2	B2	C1	C1	C1	C2	C2
<b>Output current</b>																		
Continuous (3x525-550 V) [A]	2.6	2.9	4.1	5.2	-	6.4	9.5	11.5	19	23	28	36	43	54	65	87	105	137
Intermittent (3x525-550 V) [A]	2.9	3.2	4.5	5.7	-	7.0	10.5	12.7	21	25	31	40	47	59	72	96	116	151
Continuous (3x525-600 V) [A]	2.4	2.7	3.9	4.9	-	6.1	9.0	11.0	18	22	27	34	41	52	62	83	100	131
Intermittent (3x525-600 V) [A]	2.6	3.0	4.3	5.4	-	6.7	9.9	12.1	20	24	30	37	45	57	68	91	110	144
Continuous kVA (525 V AC) [kVA]	2.5	2.8	3.9	5.0	-	6.1	9.0	11.0	18.1	21.9	26.7	34.3	41	51.4	61.9	82.9	100	130.5
Continuous kVA (575 V AC) [kVA]	2.4	2.7	3.9	4.9	-	6.1	9.0	11.0	17.9	21.9	26.9	33.9	40.8	51.8	61.7	82.7	99.6	130.5
Max. cable size, IP21/55/66 (mains, motor, brake) [mm <sup>2</sup> ]/[AWG] <sup>2)</sup>			4/10						10/7				25/4		50/1/0		120/MCM2 50	
Max. cable size, IP20 (mains, motor, brake) [mm <sup>2</sup> ]/[AWG] <sup>2)</sup>			4/10						16/6				35/2		50/1/0		150/MCM2 50 <sup>3)</sup>	
With mains disconnect switch included:			4/10						16/6				35/2		70/3/0		185/kcmil3 50	

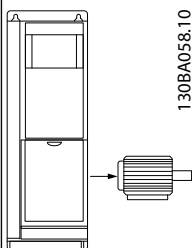
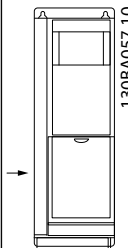
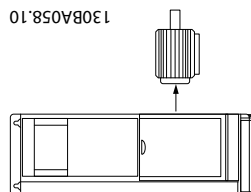

Table 9.5 <sup>3)</sup> With Brake and Load Sharing 95/4/0

Mains supply 3x525-600 VAC Normal overload 110% for 1 minute - continued																		
Size:	P1K1	P1K5	P2K2	P3K0	P3K7	P4K0	P5K5	P7K5	P11K	P15K	P18K	P22K	P30K	P37K	P45K	P55K	P75K	P90K
Max. input current 	2.4	2.7	4.1	5.2	-	5.8	8.6	10.4	17.2	20.9	25.4	32.7	39	49	59	78.9	95.3	124.3
	2.7	3.0	4.5	5.7	-	6.4	9.5	11.5	19	23	28	36	43	54	65	87	105	137
	10	10	20	20	-	20	32	32	63	63	63	63	80	100	125	160	250	250
	Environment:																	
Estimated power loss at rated max. load [W <sup>4)</sup>	50	65	92	122	-	145	195	261	300	400	475	525	700	750	850	1100	1400	1500
Weight enclosure IP20 [kg]	6.5	6.5	6.5	6.5	-	6.5	6.6	6.6	12	12	12	23.5	23.5	23.5	35	35	50	50
Weight enclosure IP21/55 [kg]	13.5	13.5	13.5	13.5	13.5	13.5	14.2	14.2	23	23	23	27	27	27	45	45	65	65
Efficiency <sup>4)</sup>	0.97	0.97	0.97	0.97	-	0.97	0.97	0.97	0.98	0.98	0.98	0.98	0.98	0.98	0.98	0.98	0.98	0.98

 Table 9.6<sup>5)</sup> With Brake and Load Sharing 95/ 4/0

Mains Supply 3x525-690 V AC							
Frequency Converter	<b>P1K1</b>	<b>P1K5</b>	<b>P2K2</b>	<b>P3K0</b>	<b>P4K0</b>	<b>P5K5</b>	<b>P7K5</b>
Typical Shaft Output [kW]	1.1	1.5	2.2	3	4	5.5	7.5
Enclosure IP20 (only)	A3	A3	A3	A3	A3	A3	A3
<b>Output current</b> High overload 110% for 1 min							
Continuous (3x525-550 V) [A]	2.1	2.7	3.9	4.9	6.1	9	11
Intermittent (3x525-550 V) [A]	2.3	3.0	4.3	5.4	6.7	9.9	12.1
Continuous kVA (3x551-690 V) [A]	1.6	2.2	3.2	4.5	5.5	7.5	10
Intermittent kVA (3x551-690 V) [A]	1.8	2.4	3.5	4.9	6.0	8.2	11
Continuous kVA 525 V AC	1.9	2.6	3.8	5.4	6.6	9	12
Continuous kVA 690 V AC	1.9	2.6	3.8	5.4	6.6	9	12
<b>Max. input current</b>							
Continuous (3x525-550 V) [A]	1.9	2.4	3.5	4.4	5.5	8	10
Intermittent (3x525-550 V) [A]	2.1	2.6	3.8	8.4	6.0	8.8	11
Continuous kVA (3x551-690 V) [A]	1.4	2.0	2.9	4.0	4.9	6.7	9
Intermittent kVA (3x551-690 V) [A]	1.5	2.2	3.2	4.4	5.4	7.4	9.9
<b>Additional specifications</b>							
IP20 max. cable cross section <sup>5)</sup> (mains, motor, brake and load sharing) [mm <sup>2</sup> ]/(AWG)	[0.2-4]/(24-10)						
Estimated power loss at rated max. load [W] <sup>4)</sup>	44	60	88	120	160	220	300
Weight, enclosure IP20 [kg]	6.6	6.6	6.6	6.6	6.6	6.6	6.6
Efficiency <sup>4)</sup>	0.96	0.96	0.96	0.96	0.96	0.96	0.96

Table 9.7 Mains Supply 3x525-690 V AC IP20

Normal overload 110% for 1 minute										
Frequency converter	P11K	P15K	P18K	P22K	P30K	P37K	P45K	P55K	P75K	P90K
Typical Shaft Output [kW]	11	15	18.5	22	30	37	45	55	75	90
Typical Shaft Output [HP] at 575 V	10	16.4	20.1	24	33	40	50	60	75	100
IP21/NEMA 1	B2	B2	B2	B2	B2	C2	C2	C2	C2	C2
IP55/NEMA 12	B2	B2	B2	B2	B2	C2	C2	C2	C2	C2
Output current										
Continuous (3x525-550 V) [A]	14	19	23	28	36	43	54	65	87	105
Intermittent (3x525-550 V) [A]	15.4	20.9	25.3	30.8	39.6	47.3	59.4	71.5	95.7	115.5
Continuous (3x551-690 V) [A]	13	18	22	27	34	41	52	62	83	100
Intermittent (3x551-690 V) [A]	14.3	19.8	24.2	29.7	37.4	45.1	57.2	68.2	91.3	110
Continuous kVA (550 V AC) [kVA]	13.3	18.1	21.9	26.7	34.3	41	51.4	61.9	82.9	100
Continuous kVA (575 V AC) [kVA]	12.9	17.9	21.9	26.9	33.8	40.8	51.8	61.7	82.7	99.6
Continuous kVA (690 V AC) [kVA]	15.5	21.5	26.3	32.3	40.6	49	62.1	74.1	99.2	119.5
Max. input current										
Continuous (3x525-690 V) [A]	15	19.5	24	29	36	49	59	71	87	99
Intermittent (3x525-690 V) [A]	16.5	21.5	26.4	31.9	39.6	53.9	64.9	78.1	95.7	108.9
Max. pre-fuses <sup>1)</sup> [A]	63	63	63	63	80	100	125	160	160	160
Additional specifications										
Estimated power loss at rated max. load [W] <sup>4)</sup>	201	285	335	375	430	592	720	880	1200	1440
Max. cable size (mains, motor, brake) [mm <sup>2</sup> ]/(AWG) <sup>2)</sup>	[35]/(1/0)					[95]/(4/0)				
Weight IP21 [kg]	27	27	27	27	27	65	65	65	65	65
Weight IP55 [kg]	27	27	27	27	27	65	65	65	65	65
Efficiency <sup>4)</sup>	0.98	0.98	0.98	0.98	0.98	0.98	0.98	0.98	0.98	0.98

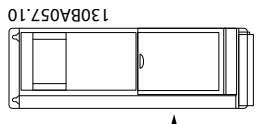
Table 9.8 Mains Supply 3x525-690 V AC IP21-IP55/NEMA 1-NEMA 12

Normal overload 110% for 1 minute		
Frequency converter	P45K	P55K
Typical Shaft Output [kW]	45	55
Typical Shaft Output [HP] at 575 V	60	75
IP20/Chassis	C3	C3
Output current		
Continuous (3x525-550 V) [A]	54	65
Intermittent (3x525-550 V) [A]	59.4	71.5
Continuous (3x551-690 V) [A]	52	62
Intermittent (3x551-690 V) [A]	57.2	68.2
Continuous kVA (550 V AC) [kVA]	51.4	62
Continuous kVA (575 V AC) [kVA]	62.2	74.1
Continuous kVA (690 V AC) [kVA]	62.2	74.1
Max. input current		
Continuous (3x525-550 V) [A]	52	63
Intermittent (3x525-550 V) [A]	57.2	69.3
Continuous (3x551-690 V) [A]	50	60
Intermittent (3x551-690 V) [A]	55	66
Max. pre-fuses <sup>1)</sup> [A]	100	125
Additional specifications		
Estimated power loss at rated max. load [W] <sup>4)</sup>	592	720
Max. cable size (mains, motor, brake) [mm <sup>2</sup> ]/(AWG) <sup>2)</sup>	50 (1)	
Weight IP20 [kg]	35	35
Efficiency <sup>4)</sup>	0.98	0.98

**Table 9.9 Mains Supply 3x525-690 V IP20**

<sup>1)</sup> For type of fuse, see chapter 6.2 Fuses and Circuit Breakers

<sup>2)</sup> American Wire Gauge

<sup>3)</sup> Measured using 5 m screened motor cables at rated load and rated frequency

<sup>4)</sup> The typical power loss is at normal load conditions and expected to be within  $\pm 15\%$  (tolerance relates to variety in voltage and cable conditions).

Values are based on a typical motor efficiency (IE1/IE2 border line). Lower efficiency motors will also add to the power loss in the frequency converter and vice versa.

If the switching frequency is raised from nominal the power losses may rise significantly.

LCP and typical control card power consumptions are included. Further options and customer load may add up to 30 W to the losses. (Though typically only 4 W extra for a fully loaded control card or options for slot A or slot B, each).

Although measurements are made with state of the art equipment, some measurement inaccuracy must be allowed for ( $\pm 5\%$ ).

<sup>5)</sup> Motor and mains cable: 300 MCM/150 mm<sup>2</sup>

## 9.2 General Specifications

### Mains supply (L1, L2, L3)

Supply voltage	200-240 V $\pm 10\%$ , 380-480 V $\pm 10\%$ , 525-690 V $\pm 10\%$
----------------	--

#### Mains voltage low / mains drop-out:

During low mains voltage or a mains drop-out, the FC continues until the intermediate circuit voltage drops below the minimum stop level, which corresponds typically to 15% below the FC's lowest rated supply voltage. Power-up and full torque cannot be expected at mains voltage lower than 10% below the FC's lowest rated supply voltage.

Supply frequency	50/60 Hz $\pm 5\%$
------------------	--------------------

Max. imbalance temporary between mains phases	3.0 % of rated supply voltage
---	-------------------------------

True Power Factor ()	$\geq 0.9$ nominal at rated load
----------------------	----------------------------------

Displacement Power Factor (cos) near unity	( $> 0.98$ )
--	--------------

Switching on input supply L1, L2, L3 (power-ups) $\leq$ enclosure type A	maximum twice/min.
--	--------------------

Switching on input supply L1, L2, L3 (power-ups) $\geq$ enclosure type B, C	maximum once/min.
---	-------------------

Switching on input supply L1, L2, L3 (power-ups) $\geq$ enclosure type D, E, F	maximum once/2 min.
--	---------------------

Environment according to EN60664-1	overvoltage category III / pollution degree 2
------------------------------------	---

The unit is suitable for use on a circuit capable of delivering not more than 100.000 RMS symmetrical Amperes, 480/600 V maximum.

### Motor output (U, V, W)

Output voltage	0 - 100% of supply voltage
----------------	----------------------------

Output frequency	0 - 590 Hz*
------------------	-------------

Switching on output	Unlimited
---------------------	-----------

Ramp times	1 - 3600 s
------------	------------

\* Dependent on power size.

### Torque characteristics

Starting torque (Constant torque)	maximum 110% for 1 min.*
-----------------------------------	--------------------------

Starting torque	maximum 135% up to 0.5 s*
-----------------	---------------------------

Overload torque (Constant torque)	maximum 110% for 1 min.*
-----------------------------------	--------------------------

\*Percentage relates to the frequency converter's nominal torque.

### Cable lengths and cross sections

Max. motor cable length, screened/armoured	VLT <sup>®</sup> HVAC Drive: 150 m
--	------------------------------------

Max. motor cable length, unscreened/unarmoured	VLT <sup>®</sup> HVAC Drive: 300 m
--	------------------------------------

Max. cross section to motor, mains, load sharing and brake *	
--	--

Maximum cross section to control terminals, rigid wire	1.5 mm <sup>2</sup> /16 AWG (2 x 0.75 mm <sup>2</sup> )
--	---

Maximum cross section to control terminals, flexible cable	1 mm <sup>2</sup> /18 AWG
--	---------------------------

Maximum cross section to control terminals, cable with enclosed core	0.5 mm <sup>2</sup> /20 AWG
--	-----------------------------

Minimum cross section to control terminals	0.25 mm <sup>2</sup>
--	----------------------

\* See Mains Supply tables for more information!

### Digital inputs

Programmable digital inputs	4 (6)
-----------------------------	-------

Terminal number	18, 19, 27 <sup>1)</sup> , 29 <sup>1)</sup> , 32, 33,
-----------------	---

Logic	PNP or NPN
-------	------------

Voltage level	0-24 V DC
---------------	-----------

Voltage level, logic '0' PNP	<5 V DC
------------------------------	---------

Voltage level, logic '1' PNP	>10 V DC
------------------------------	----------

Voltage level, logic '0' NPN	>19 V DC
------------------------------	----------

Voltage level, logic '1' NPN	<14 V DC
------------------------------	----------

Maximum voltage on input	28 V DC
--------------------------	---------

Input resistance, R <sub>i</sub>	approx. 4 k $\Omega$
----------------------------------	----------------------

All digital inputs are galvanically isolated from the supply voltage (PELV) and other high-voltage terminals.

1) Terminals 27 and 29 can also be programmed as output.

Analog inputs

Number of analog inputs	2
Terminal number	53, 54
Modes	Voltage or current
Mode select	Switch S201 and switch S202
Voltage mode	Switch S201/switch S202 = OFF (U)
Voltage level	0 to +10 V (scaleable)
Input resistance, $R_i$	approx. 10 k $\Omega$
Max. voltage	$\pm 20$ V
Current mode	Switch S201/switch S202 = ON (I)
Current level	0/4 to 20 mA (scaleable)
Input resistance, $R_i$	approx. 200 $\Omega$
Max. current	30 mA
Resolution for analog inputs	10 bit (+ sign)
Accuracy of analog inputs	Max. error 0.5% of full scale
Bandwidth	200 Hz

The analog inputs are galvanically isolated from the supply voltage (PELV) and other high-voltage terminals.

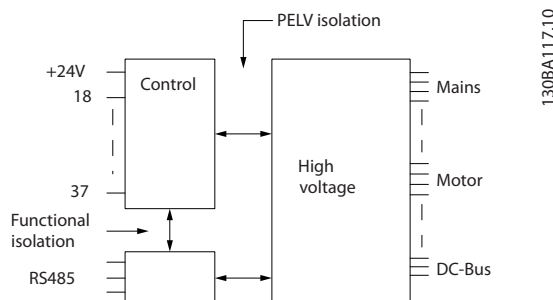

Illustration 9.1 PELV Isolation of Analog Inputs

Pulse inputs

Programmable pulse inputs	2
Terminal number pulse	29, 33
Max. frequency at terminal, 29, 33	110 kHz (Push-pull driven)
Max. frequency at terminal, 29, 33	5 kHz (open collector)
Min. frequency at terminal 29, 33	4 Hz
Voltage level	see chapter 9.2.1
Maximum voltage on input	28 V DC
Input resistance, $R_i$	approx. 4 k $\Omega$
Pulse input accuracy (0.1-1 kHz)	Max. error: 0.1% of full scale

Analog output

Number of programmable analog outputs	1
Terminal number	42
Current range at analog output	0/4-20 mA
Max. resistor load to common at analog output	500 $\Omega$
Accuracy on analog output	Max. error: 0.8% of full scale
Resolution on analog output	8 bit

The analog output is galvanically isolated from the supply voltage (PELV) and other high-voltage terminals.

Control card, RS-485 serial communication

Terminal number	68 (P,TX+, RX+), 69 (N,TX-, RX-)
Terminal number 61	Common for terminals 68 and 69

The RS-485 serial communication circuit is functionally seated from other central circuits and galvanically isolated from the supply voltage (PELV).

Digital output	
Programmable digital/pulse outputs	2
Terminal number	27, 29 <sup>1)</sup>
Voltage level at digital/frequency output	0-24 V
Max. output current (sink or source)	40 mA
Max. load at frequency output	1 k $\Omega$
Max. capacitive load at frequency output	10 nF
Minimum output frequency at frequency output	0 Hz
Maximum output frequency at frequency output	32 kHz
Accuracy of frequency output	Max. error: 0.1% of full scale
Resolution of frequency outputs	12 bit

1) Terminal 27 and 29 can also be programmed as input.

The digital output is galvanically isolated from the supply voltage (PELV) and other high-voltage terminals.

Control card, 24 V DC output	
Terminal number	12, 13
Max. load	200 mA

The 24 V DC supply is galvanically isolated from the supply voltage (PELV), but has the same potential as the analog and digital inputs and outputs.

Relay outputs	
Programmable relay outputs	2
<b>Relay 01 Terminal number</b>	1-3 (break), 1-2 (make)
Max. terminal load (AC-1) <sup>1)</sup> on 1-3 (NC), 1-2 (NO) (Resistive load)	240 V AC, 2 A
Max. terminal load (AC-15) <sup>1)</sup> (Inductive load @ $\cos\phi$ 0.4)	240 V AC, 0.2 A
Max. terminal load (DC-1) <sup>1)</sup> on 1-2 (NO), 1-3 (NC) (Resistive load)	60 V DC, 1 A
Max. terminal load (DC-13) <sup>1)</sup> (Inductive load)	24 V DC, 0.1 A
<b>Relay 02 Terminal number</b>	4-6 (break), 4-5 (make)
Max. terminal load (AC-1) <sup>1)</sup> on 4-5 (NO) (Resistive load) <sup>2)3)</sup>	400 V AC, 2 A
Max. terminal load (AC-15) <sup>1)</sup> on 4-5 (NO) (Inductive load @ $\cos\phi$ 0.4)	240 V AC, 0.2 A
Max. terminal load (DC-1) <sup>1)</sup> on 4-5 (NO) (Resistive load)	80 V DC, 2 A
Max. terminal load (DC-13) <sup>1)</sup> on 4-5 (NO) (Inductive load)	24 V DC, 0.1 A
Max. terminal load (AC-1) <sup>1)</sup> on 4-6 (NC) (Resistive load)	240 V AC, 2 A
Max. terminal load (AC-15) <sup>1)</sup> on 4-6 (NC) (Inductive load @ $\cos\phi$ 0.4)	240 V AC, 0.2 A
Max. terminal load (DC-1) <sup>1)</sup> on 4-6 (NC) (Resistive load)	50 V DC, 2 A
Max. terminal load (DC-13) <sup>1)</sup> on 4-6 (NC) (Inductive load)	24 V DC, 0.1 A
Min. terminal load on 1-3 (NC), 1-2 (NO), 4-6 (NC), 4-5 (NO)	24 V DC 10 mA, 24 V AC 20 mA
Environment according to EN 60664-1	overvoltage category III/pollution degree 2

1) IEC 60947 parts 4 and 5

The relay contacts are galvanically isolated from the rest of the circuit by reinforced isolation (PELV).

2) Overvoltage Category II

3) UL applications 300 V AC 2 A

Control card, 10 V DC output	
Terminal number	50
Output voltage	10.5 V $\pm$ 0.5 V
Max. load	25 mA

The 10 V DC supply is galvanically isolated from the supply voltage (PELV) and other high-voltage terminals.

Control characteristics	
Resolution of output frequency at 0 - 590 Hz	$\pm$ 0.003 Hz
System response time (terminals 18, 19, 27, 29, 32, 33)	$\leq$ 2 ms
Speed control range (open loop)	1:100 of synchronous speed



Speed accuracy (open loop) 30-4000 rpm: Maximum error of  $\pm 8$  rpm

*All control characteristics are based on a 4-pole asynchronous motor*

Surroundings

Enclosure type A IP 20/Chassis, IP 21kit/Type 1, IP55/Type12, IP 66/Type12

Enclosure type B1/B2 IP 21/Type 1, IP55/Type12, IP 66/12

Enclosure type B3/B4 IP20/Chassis

Enclosure type C1/C2 IP 21/Type 1, IP55/Type 12, IP66/12

Enclosure type C3/C4 IP20/Chassis

Enclosure kit available IP21/NEMA 1/IP 4x on top of enclosure

Vibration test enclosure A, B, C 1.0 g

Relative humidity 5% - 95% (IEC 721-3-3; Class 3K3 (non-condensing) during operation

Aggressive environment (IEC 60068-2-43) H<sub>2</sub>S test class Kd

Test method according to IEC 60068-2-43 H<sub>2</sub>S (10 days)

Ambient temperature (at 60 AVM switching mode)

- with derating max. 55° C<sup>1)</sup>

- with full output power of typical IE2 motors (up to 90% output current) max. 50 ° C<sup>1)</sup>

- at full continuous FC output current max. 45 ° C<sup>1)</sup>

<sup>1)</sup> For more information on derating see chapter 9.6 Special Conditions

Minimum ambient temperature during full-scale operation 0 °C

Minimum ambient temperature at reduced performance - 10 °C

Temperature during storage/transport -25 - +65/70 °C

Maximum altitude above sea level without derating 1000 m

Maximum altitude above sea level with derating 3000 m

*Derating for high altitude, see chapter 9.6 Special Conditions*

EMC standards, Emission EN 61800-3, EN 61000-6-3/4, EN 55011, IEC 61800-3

EN 61800-3, EN 61000-6-1/2,

EMC standards, Immunity EN 61000-4-2, EN 61000-4-3, EN 61000-4-4, EN 61000-4-5, EN 61000-4-6

*See chapter 9.6 Special Conditions*

Control card performance

Scan interval 5 ms

Control card, USB serial communication

USB standard 1.1 (Full speed)

USB plug USB type B "device" plug

## CAUTION

Connection to PC is carried out via a standard host/device USB cable.

The USB connection is galvanically isolated from the supply voltage (PELV) and other high-voltage terminals.

The USB connection is not galvanically isolated from protection earth. Use only isolated laptop/PC as connection to the USB connector on or an isolated USB cable/converter.

### Protection and Features

- Electronic thermal motor protection against overload.
- Temperature monitoring of the heatsink ensures that the frequency converter trips, if the temperature reaches  $95\text{ °C} \pm 5\text{ °C}$ . An overload temperature cannot be reset until the temperature of the heatsink is below  $70\text{ °C} \pm 5\text{ °C}$  (Guideline - these temperatures may vary for different power sizes, enclosures etc.). The has an auto derating function to avoid it's heatsink reaching  $95\text{ °C}$ .
- The frequency converter is protected against short circuits on motor terminals U, V, W.
- If a mains phase is missing, the frequency converter trips or issues a warning (depending on the load).
- Monitoring of the intermediate circuit voltage ensures that the frequency converter trips, if the intermediate circuit voltage is too low or too high.
- The frequency converter is protected against earth faults on motor terminals U, V, W.

9

## 9.3 Efficiency

### Efficiency of the frequency converter ( $\eta_{VLT}$ )

The load on the frequency converter has little effect on its efficiency. In general, the efficiency is the same at the rated motor frequency  $f_{M,N}$ , even if the motor supplies 100% of the rated shaft torque or only 75%, i.e. in case of part loads.

This also means that the efficiency of the frequency converter does not change even if other U/f characteristics are chosen.

However, the U/f characteristics influence the efficiency of the motor.

The efficiency declines a little when the switching frequency is set to a value of above 5 kHz. The efficiency will also be slightly reduced if the mains voltage is 480V.

### Frequency converter efficiency calculation

Calculate the efficiency of the frequency converter at different loads based on *Illustration 9.2*. The factor in this graph must be multiplied with the specific efficiency factor listed in the specification tables:

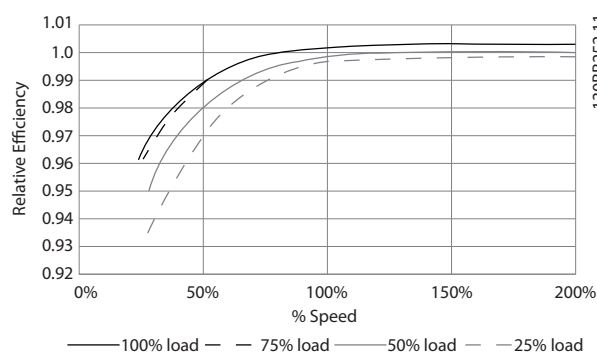

Illustration 9.2 Typical Efficiency Curves

Example: Assume a 22 kW, 380-480V AC frequency converter runs at 25% load at 50% speed. The graph shows 0.97 - rated efficiency for a 22 kW FC is 0.98. The actual efficiency is then:  $0.97 \times 0.98 = 0.95$ .

### Efficiency of the motor ( $\eta_{MOTOR}$ )

The efficiency of a motor connected to the frequency converter depends on the magnetizing level. In general, the efficiency is just as good as with mains operation. The efficiency of the motor depends on the type of motor.

In the range of 75-100% of the rated torque, the efficiency of the motor is practically constant, both when it is controlled by the frequency converter and when it runs directly on mains.

In small motors, the influence from the U/f characteristic on efficiency is marginal. However, in motors from 11 kW and up, the advantages are significant.

In general, the switching frequency does not affect the efficiency of small motors. Motors from 11 kW and up have their efficiency improved (1-2%). This is because the sine shape of the motor current is almost perfect at high switching frequency.

### Efficiency of the system ( $\eta_{SYSTEM}$ )

To calculate the system efficiency, the efficiency of the frequency converter ( $\eta_{VLT}$ ) is multiplied by the efficiency of the motor ( $\eta_{MOTOR}$ ):

$$\eta_{SYSTEM} = \eta_{VLT} \times \eta_{MOTOR}$$

## 9.4 Acoustic Noise

### The acoustic noise from the frequency converter originates from 3 sources:

- DC intermediate circuit coils.
- Integral fan.
- RFI filter choke.

The typical values measured at a distance of 1 m from the unit:

Enclosure type	At reduced fan speed (50%) [dBA]	Full fan speed [dBA]
A2	51	60
A3	51	60
A4	50	55
A5	54	63
B1	61	67
B2	58	70
B3	59.4	70.5
B4	53	62.8
C1	52	62
C2	55	65
C3	56.4	67.3
C4	-	-

Table 9.10 Measured Values

## 9.5 Peak Voltage on Motor

When a transistor in the inverter bridge switches, the voltage across the motor increases by a  $dU/dt$  ratio depending on:

- the motor cable (type, cross-section, length screened or unscreened)
- inductance

The natural induction causes an overshoot  $U_{PEAK}$  in the motor voltage before it stabilises itself at a level

depending on the voltage in the intermediate circuit. The rise time and the peak voltage  $U_{PEAK}$  affect the service life of the motor. If the peak voltage is too high, especially motors without phase coil insulation are affected. If the motor cable is short (a few metres), the rise time and peak voltage are lower.

If the motor cable is long (100 m), the rise time and peak voltage increases.

In motors without phase insulation paper or other insulation reinforcement suitable for operation with voltage supply (such as a frequency converter), fit a sine-wave filter on the output of the frequency converter.

To obtain approximate values for cable lengths and voltages not mentioned below, use the following rules of thumb:

- Rise time increases/decreases proportionally with cable length.
- $U_{PEAK} = \text{DC link voltage} \times 1.9$   
(DC link voltage = Mains voltage  $\times$  1.35).
- $dU/dt = \frac{0.8 \times U_{PEAK}}{\text{Risetime}}$

Data are measured according to IEC 60034-17. Cable lengths are in metres.

Cable length [m]	Mains voltage [V]	Rise time [ $\mu\text{sec}$ ]	Vpeak [kV]	dU/dt [kV/ $\mu\text{sec}$ ]
36	240	0.226	0.616	2.142
50	240	0.262	0.626	1.908
100	240	0.650	0.614	0.757
150	240	0.745	0.612	0.655

Table 9.11 Frequency converter, P5K5, T2

Cable length [m]	Mains voltage [V]	Rise time [ $\mu\text{sec}$ ]	Vpeak [kV]	dU/dt [kV/ $\mu\text{sec}$ ]
5	230	0.13	0.510	3.090
50	230	0.23	0.590	2.034
100	230	0.54	0.580	0.865
150	230	0.66	0.560	0.674

Table 9.12 Frequency converter, P7K5, T2

Cable length [m]	Mains voltage [V]	Rise time [ $\mu\text{sec}$ ]	Vpeak [kV]	dU/dt [kV/ $\mu\text{sec}$ ]
36	240	0.264	0.624	1.894
136	240	0.536	0.596	0.896
150	240	0.568	0.568	0.806

Table 9.13 Frequency converter, P11K, T2

Cable length [m]	Mains voltage [V]	Rise time [ $\mu$ sec]	Vpeak [kV]	dU/dt [kV/ $\mu$ sec]
30	240	0.556	0.650	0.935
100	240	0.592	0.594	0.807
150	240	0.708	0.575	0.669

Table 9.14 Frequency converter, P15K, T2

Cable length [m]	Mains voltage [V]	Rise time [ $\mu$ sec]	Vpeak [kV]	dU/dt [kV/ $\mu$ sec]
36	240	0.244	0.608	1.993
136	240	0.568	0.580	0.832
150	240	0.720	0.574	0.661

Table 9.15 Frequency converter, P18K, T2

Cable length [m]	Mains voltage [V]	Rise time [ $\mu$ sec]	Vpeak [kV]	dU/dt [kV/ $\mu$ sec]
36	240	0.244	0.608	1.993
136	240	0.560	0.580	0.832
150	240	0.720	0.574	0.661

Table 9.16 Frequency converter, P22K, T2

Cable length [m]	Mains voltage [V]	Rise time [ $\mu$ sec]	Vpeak [kV]	dU/dt [kV/ $\mu$ sec]
15	240	0.194	0.626	2.581
50	240	0.252	0.574	1.929
150	240	0.444	0.538	0.977

Table 9.17 Frequency converter, P30K, T2

Cable length [m]	Mains voltage [V]	Rise time [ $\mu$ sec]	Vpeak [kV]	dU/dt [kV/ $\mu$ sec]
30	240	0.300	0.598	1.593
100	240	0.536	0.566	0.843
150	240	0.776	0.546	0.559

Table 9.18 Frequency converter, P37K, T2

Cable length [m]	Mains voltage [V]	Rise time [ $\mu$ sec]	Vpeak [kV]	dU/dt [kV/ $\mu$ sec]
30	240	0.300	0.598	1.593
100	240	0.536	0.566	0.843
150	240	0.776	0.546	0.559

Table 9.19 Frequency converter, P45K, T2

Cable length [m]	Mains voltage [V]	Rise time [ $\mu$ sec]	Vpeak [kV]	dU/dt [kV/ $\mu$ sec]
5	400	0.640	0.690	0.862
50	400	0.470	0.985	0.985
150	400	0.760	1.045	0.947

Table 9.20 Frequency converter, P1K5, T4

Cable length [m]	Mains voltage [V]	Rise time [ $\mu$ sec]	Vpeak [kV]	dU/dt [kV/ $\mu$ sec]
5	400	0.172	0.890	4.156
50	400	0.310		2.564
150	400	0.370	1.190	1.770

Table 9.21 Frequency converter, P4K0, T4

Cable length [m]	Mains voltage [V]	Rise time [ $\mu$ sec]	Vpeak [kV]	dU/dt [kV/ $\mu$ sec]
5	400	0.04755	0.739	8.035
50	400	0.207	1.040	4.548
150	400	0.6742	1.030	2.828

Table 9.22 Frequency converter, P7K5, T4

Cable length [m]	Mains voltage [V]	Rise time [ $\mu$ sec]	Vpeak [kV]	dU/dt [kV/ $\mu$ sec]
15	400	0.408	0.718	1.402
100	400	0.364	1.050	2.376
150	400	0.400	0.980	2.000

Table 9.23 Frequency converter, P11K, T4

Cable length [m]	Mains voltage [V]	Rise time [ $\mu$ sec]	Vpeak [kV]	dU/dt [kV/ $\mu$ sec]
36	400	0.422	1.060	2.014
100	400	0.464	0.900	1.616
150	400	0.896	1.000	0.915

Table 9.24 Frequency converter, P15K, T4

Cable length [m]	Mains voltage [V]	Rise time [ $\mu$ sec]	Vpeak [kV]	dU/dt [kV/ $\mu$ sec]
36	400	0.344	1.040	2.442
100	400	1.000	1.190	0.950
150	400	1.400	1.040	0.596

Table 9.25 Frequency converter, P18K, T4

Cable length [m]	Mains voltage [V]	Rise time [ $\mu$ sec]	Vpeak [kV]	dU/dt [kV/ $\mu$ sec]
36	400	0.232	0.950	3.534
100	400	0.410	0.980	1.927
150	400	0.430	0.970	1.860

Table 9.26 Frequency converter, P22K, T4

Cable length [m]	Mains voltage [V]	Rise time [ $\mu$ sec]	Vpeak [kV]	dU/dt [kV/ $\mu$ sec]
15	400	0.271	1.000	3.100
100	400	0.440	1.000	1.818
150	400	0.520	0.990	1.510

Table 9.27 Frequency converter, P30K, T4

Cable length [m]	Mains voltage	Rise time [μsec]	Vpeak [kV]	dU/dt [kV/μsec]
5	480	0.270	1.276	3.781
50	480	0.435	1.184	2.177
100	480	0.840	1.188	1.131
150	480	0.940	1.212	1.031

Table 9.28 Frequency converter, P37K, T4

Cable length [m]	Mains voltage [V]	Rise time [μsec]	Vpeak [kV]	dU/dt [kV/μsec]
36	400	0.254	1.056	3.326
50	400	0.465	1.048	1.803
100	400	0.815	1.032	1.013
150	400	0.890	1.016	0.913

Table 9.29 Frequency converter, P45K, T4

Cable length [m]	Mains voltage [V]	Rise time [μsec]	Vpeak [kV]	dU/dt [kV/μsec]
10	400	0.350	0.932	2.130

Table 9.30 Frequency converter, P55K, T4

Cable length [m]	Mains voltage [V]	Rise time [μsec]	Vpeak [kV]	dU/dt [kV/μsec]
5	480	0.371	1.170	2.466

Table 9.31 Frequency converter, P75K, T4

Cable length [m]	Mains voltage [V]	Rise time [μsec]	Vpeak [kV]	dU/dt [kV/μsec]
5	400	0.364	1.030	2.264

Table 9.32 Frequency converter, P90K, T4

9

## 9.6 Special Conditions

### 9.6.1 Purpose of Derating

Take derating into account when using the frequency converter at low air pressure (high altitudes), at low speeds, with long motor cables, cables with a large cross section or at high ambient temperature. This section describes the actions required.

### 9.6.2 Derating for Ambient Temperature

90% frequency converter output current can be maintained up to max. 50 °C ambient temperature.

With a typical full load current of IE2 motors, full output shaft power can be maintained up to 50 °C.

For more specific data and/or derating information for other motors or conditions, contact Danfoss.

### 9.6.3 Derating for Ambient Temperature, Enclosure Type A

#### 60° AVM - Pulse Width Modulation

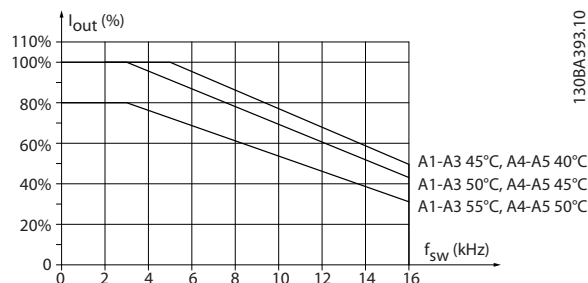
 Illustration 9.3 Derating of  $I_{out}$  for Different  $T_{AMB, MAX}$  for Enclosure Type A, using 60° AVM

**SFAVM - Stator Frequency Asynchron Vector Modulation**

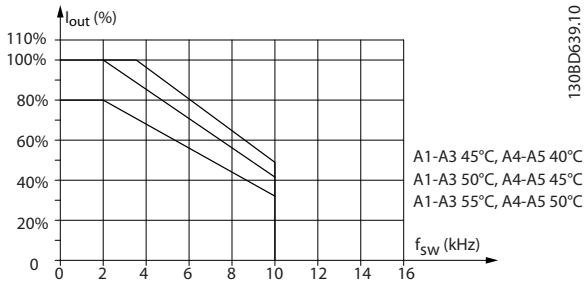

**Illustration 9.4 Derating of  $I_{out}$  for Different  $T_{AMB, MAX}$  for Enclosures Type A, using SFAVM**

When using only 10 m motor cable or less in enclosure type A, less derating is necessary. This is due to the fact that the length of the motor cable has a relatively high impact on the recommended derating.

**60° AVM**

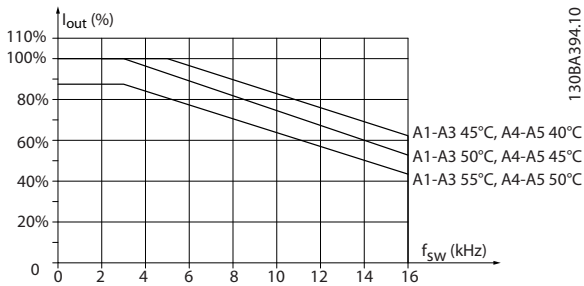

**Illustration 9.5 Derating of  $I_{out}$  for Different  $T_{AMB, MAX}$  for Enclosures Type A, using 60° AVM and maximum 10 m motor cable**

**SFAVM**

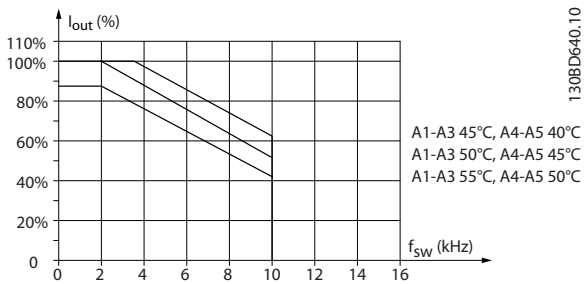

**Illustration 9.6 Derating of  $I_{out}$  for Different  $T_{AMB, MAX}$  for Enclosures Type A, using SFAVM and maximum 10 m motor cable**

**9.6.3.1 Enclosure Type A3, T7**

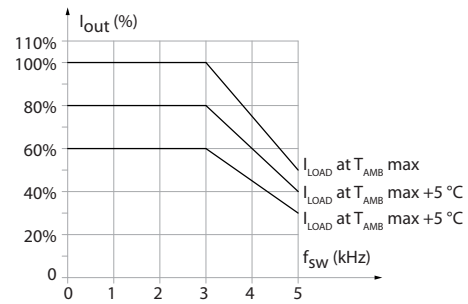

**Illustration 9.7 Derating of  $I_{out}$  for Different  $T_{AMB, MAX}$  for Enclosure Type A3**

**9.6.4 Derating for Ambient Temperature, Enclosure Type B**

**9.6.4.1 Enclosure Type B, T2, T4 and T5**

For the B and C enclosure types the derating also depends on the overload mode selected in *1-04 Overload Mode*

**60° AVM - Pulse Width Modulation**

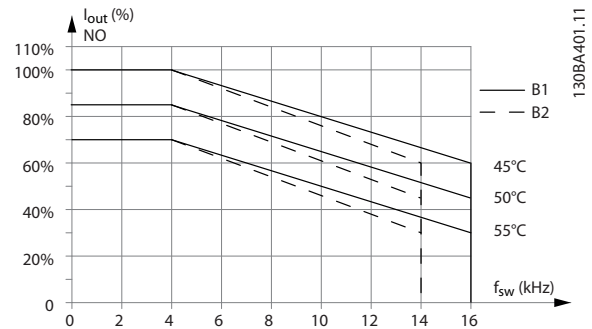

**Illustration 9.8 Derating of  $I_{out}$  for different  $T_{AMB, MAX}$  for enclosure types B1 and B2, using 60° AVM in Normal overload mode (110% over torque)**

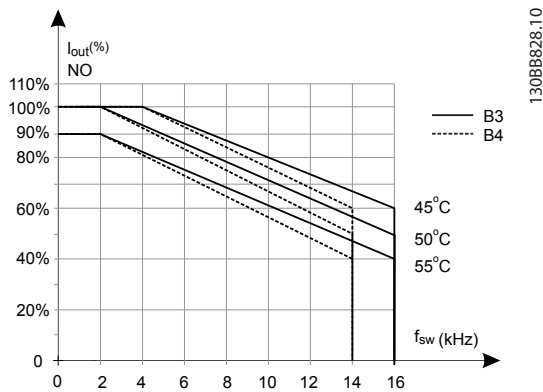

Illustration 9.9 Derating of  $I_{out}$  for different  $T_{AMB, MAX}$  for enclosure types B3 and B4, using 60° AVM in Normal overload mode (110% over torque)

### 9.6.4.2 Enclosure Type B, T6

#### 60° AVM - Pulse Width Modulation

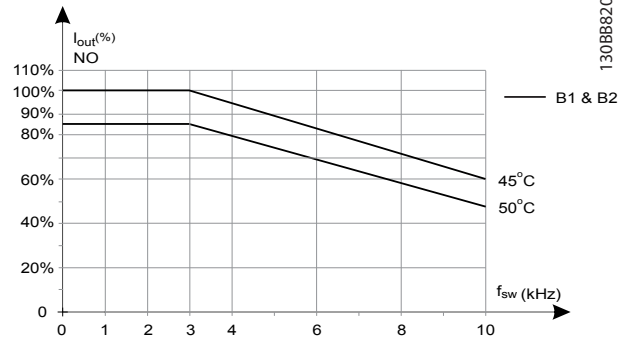

Illustration 9.12 Output current derating with switching frequency and ambient temperature for 600 V frequency converters, enclosure type B, 60 AVM, NO

#### SFAVM - Stator Frequency Asyncon Vector Modulation

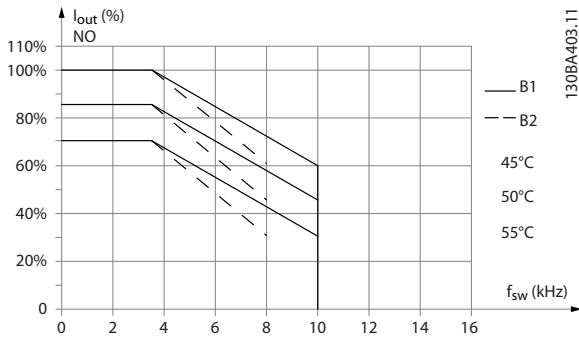

Illustration 9.10 Derating of  $I_{out}$  for different  $T_{AMB, MAX}$  for enclosure types B1 and B2, using SFAVM in Normal overload mode (110% over torque)

#### SFAVM - Stator Frequency Asyncon Vector Modulation

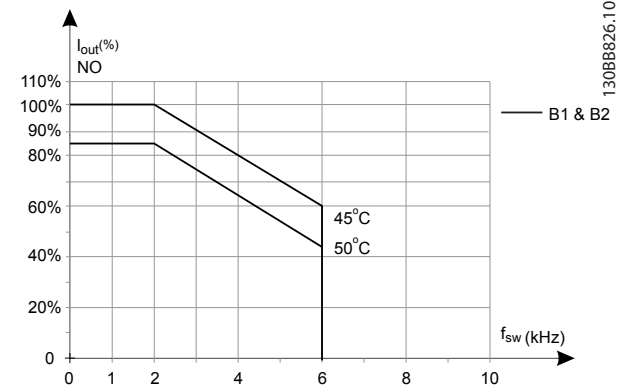

Illustration 9.13 Output current derating with switching frequency and ambient temperature for 600 V frequency converters, enclosure type B, SFAVM, NO

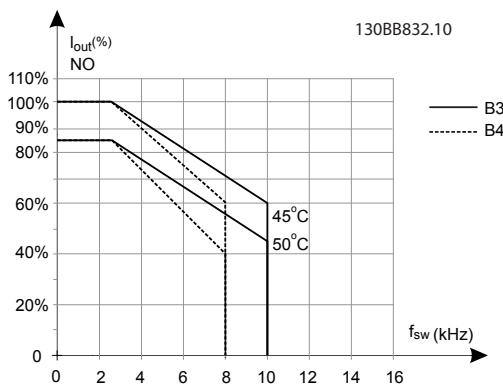

Illustration 9.11 Derating of  $I_{out}$  for different  $T_{AMB, MAX}$  for enclosure types B3 and B4, using SFAVM in Normal overload mode (110% over torque)



### 9.6.4.3 Enclosure Type B, T7

#### Enclosure Type B2, 525-690 V

#### 60° AVM - Pulse Width Modulation

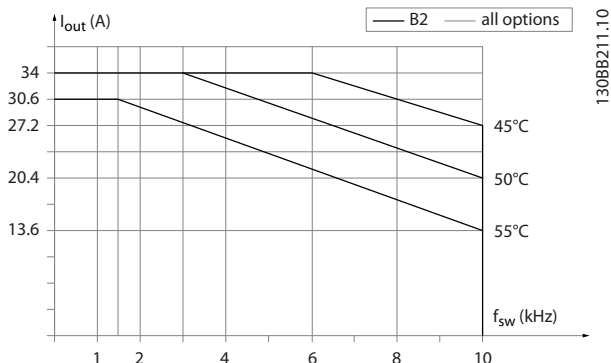

Illustration 9.14 Output current derating with switching frequency and ambient temperature for enclosure type B2, 60° AVM. Note: The graph is drawn with the current as absolute value and is valid for both high and normal overload.

#### SFAVM - Stator Frequency Asynchron Vector Modulation

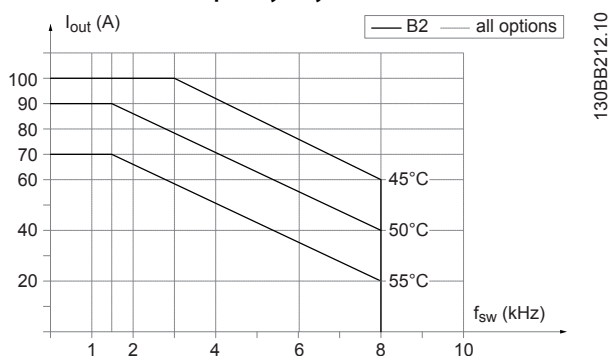

Illustration 9.15 Output current derating with switching frequency and ambient temperature for enclosure type B2, SFAVM. Note: The graph is drawn with the current as absolute value and is valid for both high and normal overload.

### 9.6.5 Derating for Ambient Temperature, Enclosure Type C

#### 9.6.5.1 Enclosure Type C, T2, T4 and T5

#### 60° AVM - Pulse Width Modulation

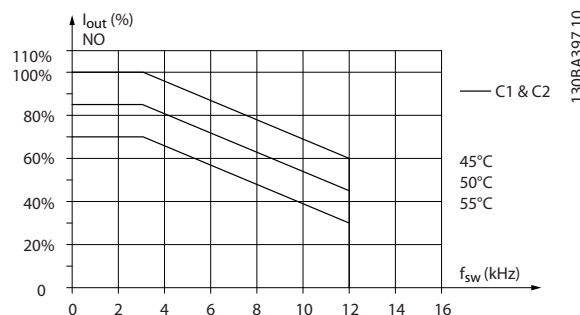

Illustration 9.16 Derating of I<sub>out</sub> for different T<sub>AMB, MAX</sub> for enclosure types C1 and C2, using 60° AVM in Normal overload mode (110% over torque)

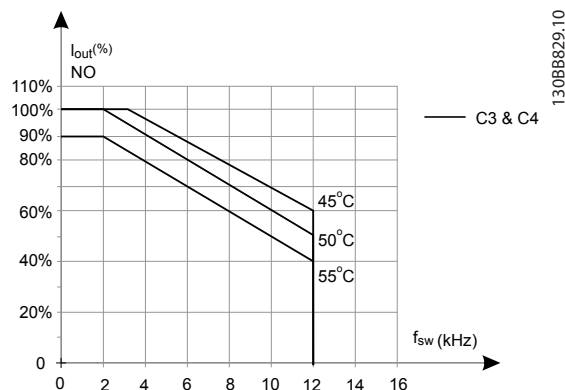

Illustration 9.17 Derating of I<sub>out</sub> for different T<sub>AMB, MAX</sub> for enclosure types C3 and C4, using 60° AVM in Normal overload mode (110% over torque)

#### SFAVM - Stator Frequency Asynchron Vector Modulation

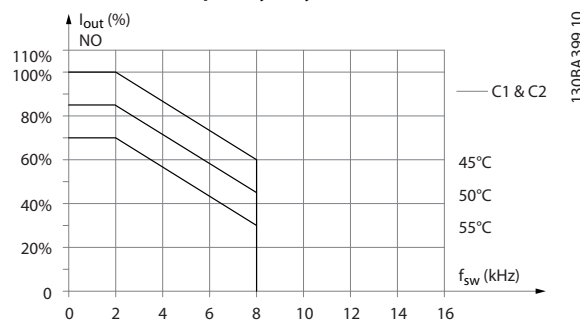

Illustration 9.18 Derating of I<sub>out</sub> for different T<sub>AMB, MAX</sub> for enclosure types C1 and C2, using SFAVM in Normal overload mode (110% over torque)

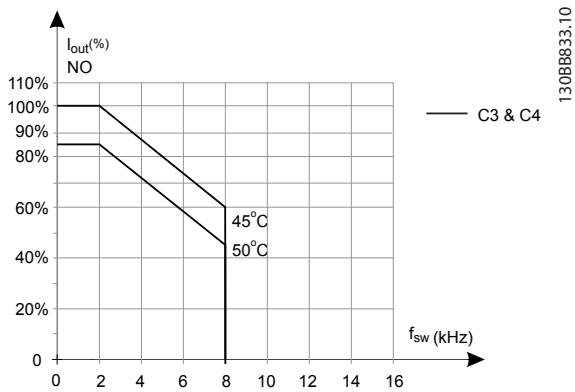

Illustration 9.19 Derating of  $I_{out}$  for different  $T_{AMB, MAX}$  for enclosure types C3 and C4, using SFAVM in Normal overload mode (110% over torque)

SFAVM - Stator Frequency Asynchron Vector Modulation

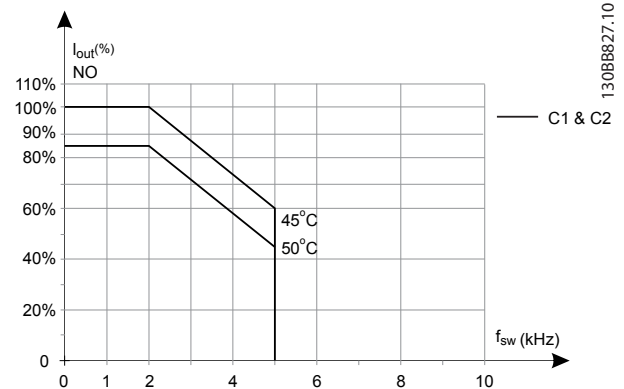

Illustration 9.21 Output current derating with switching frequency and ambient temperature for 600 V frequency converters, enclosure type C, SFAVM, NO

9.6.5.2 Enclosure Type C, T6

60° AVM - Pulse Width Modulation

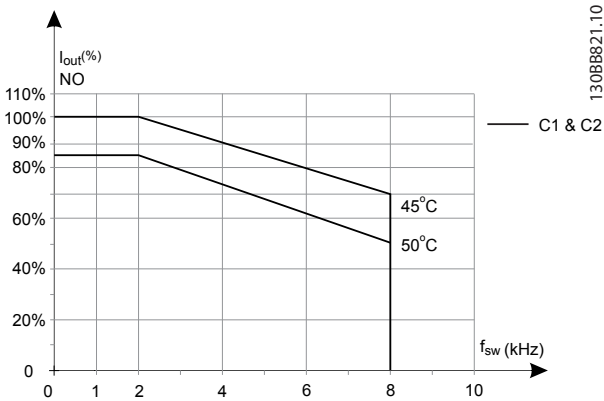

Illustration 9.20 Output current derating with switching frequency and ambient temperature for 600 V frequency converters, enclosure type C, 60° AVM, NO

9.6.5.3 Enclosure Type C, T7

60° AVM - Pulse Width Modulation

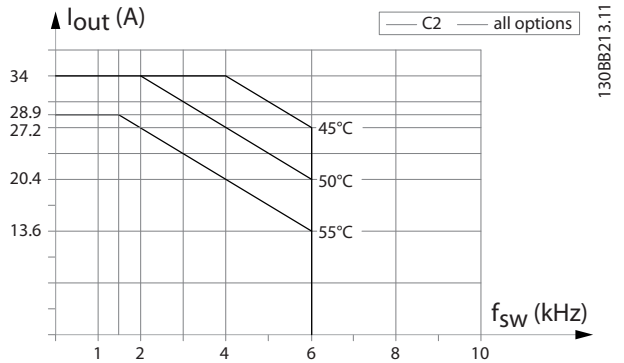
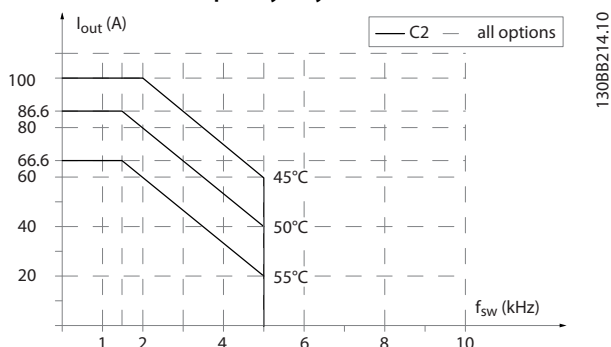
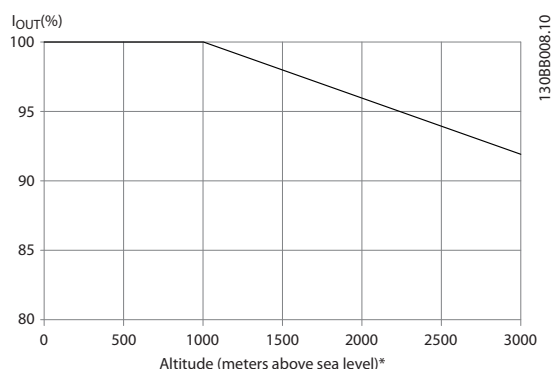

Illustration 9.22 Output current derating with switching frequency and ambient temperature for enclosure type C2, 60° AVM. Note: The graph is drawn with the current as absolute value and is valid for both high and normal overload.

**SFAVM - Stator Frequency Asynchron Vector Modulation**



**Illustration 9.23** Output current derating with switching frequency and ambient temperature for enclosure type C2, SFAVM. Note: The graph is drawn with the current as absolute value and is valid for both high and normal overload.



**Illustration 9.25** An alternative is to lower the ambient temperature at high altitudes and thereby ensure 100% output current at high altitudes

**9.6.6 Automatic Adaptations to Ensure Performance**

The frequency converter constantly checks for critical levels of internal temperature, load current, high voltage on the intermediate circuit and low motor speeds. As a response to a critical level, the frequency converter can adjust the switching frequency and/or change the switching pattern to ensure the performance of the frequency converter. The capability for automatic output current reduction extends the acceptable operating conditions even further.

**9.6.7 Derating for Low Air Pressure**

The cooling capability of air is decreased at lower air pressure.

Below 1000 m altitude no derating is necessary, but above 1000 m the ambient temperature ( $T_{AMB}$ ) or max. output current ( $I_{out}$ ) should be derated in accordance with the following diagram.

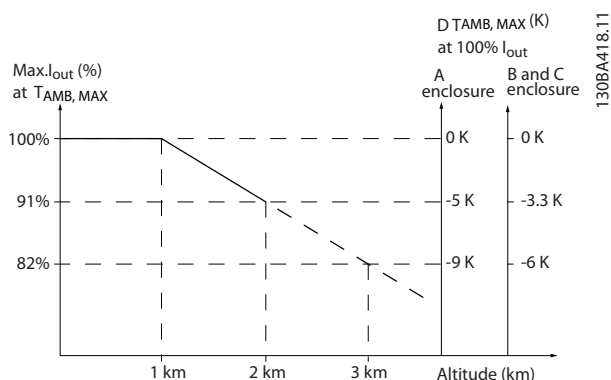

**Illustration 9.24** Derating of output current versus altitude at  $T_{AMB, MAX}$  for enclosure types A, B and C. At altitudes above 2000 m, contact Danfoss regarding PELV.

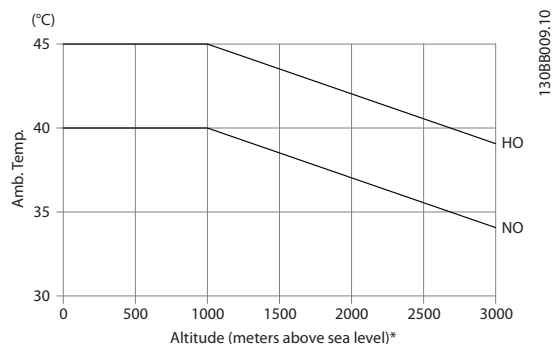

**Illustration 9.26** Example: At an altitude of 2000 m and a temperature of 45 ° C ( $T_{AMB, MAX} - 3.3$  K), 91% of the rated output current is available. At a temperature of 41.7 ° C, 100% of the rated output current is available

Derating of output current versus altitude at  $T_{AMB, MAX}$  for enclosure types D, E and F.

**9.6.8 Derating for Running at Low Speed**

When a motor is connected to a frequency converter, it is necessary to check that the cooling of the motor is adequate.

The level of heating depends on the load on the motor, as well as the operating speed and time.

**Constant torque applications (CT mode)**

A problem may occur at low RPM values in constant torque applications. In a constant torque applications, a motor may over-heat at low speeds due to less cooling air from the motor integral fan.

Therefore, if the motor is to be run continuously at an RPM value lower than half of the rated value, the motor must be supplied with additional air-cooling (or a motor designed for this type of operation may be used).

An alternative is to reduce the load level of the motor by selecting a larger motor. However, the design of the frequency converter puts a limit to the motor size.

**Variable (Quadratic) torque applications (VT)**

In VT applications such as centrifugal pumps and fans, where the torque is proportional to the square of the speed and the power is proportional to the cube of the speed, there is no need for additional cooling or de-rating of the motor.

In the graphs shown below, the typical VT curve is below the maximum torque with de-rating and maximum torque with forced cooling at all speeds.

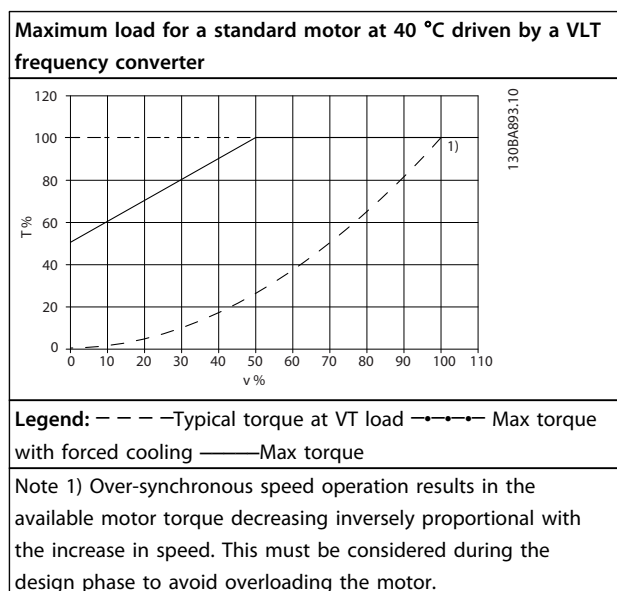

Table 9.33 Maximum load for a standard motor at 40 °C

**9.7 Troubleshooting**

A warning or an alarm is signalled by the relevant LED on the front of the and indicated by a code on the display.

A warning remains active until its cause is no longer present. Under certain circumstances, operation of the motor may still be continued. Warning messages may be critical, but are not necessarily so.

No.	Description	Warning	Alarm/Trip	Alarm/Trip Lock	Parameter Reference
1	10 V low	X			
2	Live zero error	(X)	(X)		6-01
3	No motor	(X)			1-80
4	Mains phase loss	(X)	(X)	(X)	14-12
5	DC link voltage high	X			
6	DC link voltage low	X			

In the event of an alarm, the trips. Alarms must be reset to restart operation once their cause has been rectified.

**This may be done in 4 ways:**

1. By resetting the [RESET] on the LCP.
2. Via a digital input with the "Reset" function.
3. Via serial communication/optional fieldbus.
4. By resetting automatically using the Auto Reset function, which is a default setting for VLT® HVAC Drive, see 14-20 Reset Mode in the FC 102 Programming Guide

**NOTICE**

After a manual reset pressing [RESET] on the LCP, press [Auto On] or [Hand On] to restart the motor.

If an alarm cannot be reset, the reason may be that its cause has not been rectified, or the alarm is trip-locked (see also Table 9.34).

**CAUTION**

Alarms that are trip-locked offer additional protection, means that the mains supply must be switched off before the alarm can be reset. After being switched back on, the is no longer blocked and may be reset as described above once the cause has been rectified.

Alarms that are not trip-locked can also be reset using the automatic reset function in 14-20 Reset Mode (Warning: automatic wake-up is possible!)

If a warning and alarm is marked against a code in the table on the following page, this means that either a warning occurs before an alarm, or it can be specified whether it is a warning or an alarm that is to be displayed for a given fault.

This is possible, for instance, in 1-90 Motor Thermal Protection. After an alarm or trip, the motor carries on coasting, and the alarm and warning flash on the . Once the problem has been rectified, only the alarm continues flashing.

**NOTICE**

No missing motorphase detection (no 30-32) and no stall detection is active when 1-10 Motor Construction is set to [1] PM non salient SPM.

No.	Description	Warning	Alarm/ Trip	Alarm/Trip Lock	Parameter Reference
7	DC over voltage	X	X		
8	DC under voltage	X	X		
9	Inverter overloaded	X	X		
10	Motor ETR over temperature	(X)	(X)		1-90
11	Motor thermistor over temperature	(X)	(X)		1-90
12	Torque limit	X	X		
13	Over Current	X	X	X	
14	Ground fault	X	X	X	
15	Hardware mismatch		X	X	
16	Short Circuit		X	X	
17	Control word timeout	(X)	(X)		8-04
18	Start failed		X		
23	Internal Fan Fault	X			
24	External Fan Fault	X			14-53
25	Brake resistor short-circuited	X			
26	Brake resistor power limit	(X)	(X)		2-13
27	Brake chopper short-circuited	X	X		
28	Brake check	(X)	(X)		2-15
29	Drive over temperature	X	X	X	
30	Motor phase U missing	(X)	(X)	(X)	4-58
31	Motor phase V missing	(X)	(X)	(X)	4-58
32	Motor phase W missing	(X)	(X)	(X)	4-58
33	Inrush fault		X	X	
34	Fieldbus communication fault	X	X		
35	Out of frequency range	X	X		
36	Mains failure	X	X		
37	Phase Imbalance	X	X		
38	Internal fault		X	X	
39	Heatsink sensor		X	X	
40	Overload of Digital Output Terminal 27	(X)			5-00, 5-01
41	Overload of Digital Output Terminal 29	(X)			5-00, 5-02
42	Overload of Digital Output On X30/6	(X)			5-32
42	Overload of Digital Output On X30/7	(X)			5-33
46	Pwr. card supply		X	X	
47	24 V supply low	X	X	X	
48	1.8 V supply low		X	X	
49	Speed limit	X	(X)		1-86
50	AMA calibration failed		X		
51	AMA check $U_{nom}$ and $I_{nom}$		X		
52	AMA low $I_{nom}$		X		
53	AMA motor too big		X		
54	AMA motor too small		X		
55	AMA Parameter out of range		X		
56	AMA interrupted by user		X		
57	AMA timeout		X		
58	AMA internal fault	X	X		
59	Current limit	X			
60	External Interlock	X			
62	Output Frequency at Maximum Limit	X			
64	Voltage Limit	X			
65	Control Board Over-temperature	X	X	X	
66	Heat sink Temperature Low	X			

No.	Description	Warning	Alarm/ Trip	Alarm/Trip Lock	Parameter Reference
67	Option Configuration has Changed		X		
68	Safe Stop	(X)	X <sup>1)</sup>		5-19
69	Pwr. Card Temp		X	X	
70	Illegal FC configuration			X	
71	PTC 1 Safe Stop	X	X <sup>1)</sup>		
72	Dangerous Failure			X <sup>1)</sup>	
73	Safe Stop Auto Restart				
76	Power Unit Setup	X			
79	Illegal PS config		X	X	
80	Drive Initialized to Default Value		X		
91	Analog input 54 wrong settings			X	
92	NoFlow	X	X		22-2*
93	Dry Pump	X	X		22-2*
94	End of Curve	X	X		22-5*
95	Broken Belt	X	X		22-6*
96	Start Delayed	X			22-7*
97	Stop Delayed	X			22-7*
98	Clock Fault	X			0-7*
201	Fire M was Active				
202	Fire M Limits Exceeded				
203	Missing Motor				
204	Locked Rotor				
243	Brake IGBT	X	X		
244	Heatsink temp	X	X	X	
245	Heatsink sensor		X	X	
246	Pwr.card supply		X	X	
247	Pwr.card temp		X	X	
248	Illegal PS config		X	X	
250	New spare parts			X	
251	New Type Code		X	X	

**Table 9.34 Alarm/Warning Code List**

(X) Dependent on parameter

1) Can not be Auto reset via 14-20 Reset Mode

A trip is the action when an alarm has appeared. The trip will coast the motor and can be reset by pressing [Reset] or make a reset by a digital input (parameter group 5-1\* [1]). The original event that caused an alarm cannot damage the or cause dangerous conditions. A trip lock is an action when an alarm occurs, which may cause damage to or connected parts. A Trip Lock situation can only be reset by a power cycling.

Warning	yellow
Alarm	flashing red
Trip locked	yellow and red

**Table 9.35 LED Indication**

Alarm Word and Extended Status Word					
Bit	Hex	Dec	Alarm Word	Warning Word	Extended Status Word
0	00000001	1	Brake Check	Brake Check	Ramping
1	00000002	2	Pwr. Card Temp	Pwr. Card Temp	AMA Running
2	00000004	4	Earth Fault	Earth Fault	Start CW/CCW
3	00000008	8	Ctrl.Card Temp	Ctrl.Card Temp	Slow Down
4	00000010	16	Ctrl. Word TO	Ctrl. Word TO	Catch Up
5	00000020	32	Over Current	Over Current	Feedback High
6	00000040	64	Torque Limit	Torque Limit	Feedback Low
7	00000080	128	Motor Th Over	Motor Th Over	Output Current High
8	00000100	256	Motor ETR Over	Motor ETR Over	Output Current Low
9	00000200	512	Inverter Overld.	Inverter Overld.	Output Freq High
10	00000400	1024	DC under Volt	DC under Volt	Output Freq Low
11	00000800	2048	DC over Volt	DC over Volt	Brake Check OK
12	00001000	4096	Short Circuit	DC Voltage Low	Braking Max
13	00002000	8192	Inrush Fault	DC Voltage High	Braking
14	00004000	16384	Mains ph. Loss	Mains ph. Loss	Out of Speed Range
15	00008000	32768	AMA Not OK	No Motor	OVC Active
16	00010000	65536	Live Zero Error	Live Zero Error	
17	00020000	131072	Internal Fault	10V Low	
18	00040000	262144	Brake Overload	Brake Overload	
19	00080000	524288	U phase Loss	Brake Resistor	
20	00100000	1048576	V phase Loss	Brake IGBT	
21	00200000	2097152	W phase Loss	Speed Limit	
22	00400000	4194304	Fieldbus Fault	Fieldbus Fault	
23	00800000	8388608	24 V Supply Low	24V Supply Low	
24	01000000	16777216	Mains Failure	Mains Failure	
25	02000000	33554432	1.8V Supply Low	Current Limit	
26	04000000	67108864	Brake Resistor	Low Temp	
27	08000000	134217728	Brake IGBT	Voltage Limit	
28	10000000	268435456	Option Change	Unused	
29	20000000	536870912	Drive Initialized	Unused	
30	40000000	1073741824	Safe Stop	Unused	
31	80000000	2147483648	Mech. brake low (A63)	Extended Status Word	

Table 9.36 Description of Alarm Word, Warning Word and Extended Status Word

The alarm words, warning words and extended status words can be read out via serial bus or optional fieldbus for diagnosis. See also *16-90 Alarm Word*, *16-92 Warning Word* and *16-94 Ext. Status Word*.

## 9.7.1 Alarm Words

Bit (Hex)	Alarm Word (16-90 Alarm Word)
00000001	
00000002	Power card over temperature
00000004	Earth fault
00000008	
00000010	Control word timeout
00000020	Over current
00000040	
00000080	Motor thermistor over temp.
00000100	Motor ETR over temperature
00000200	Inverter overloaded
00000400	DC link under voltage
00000800	DC link over voltage
00001000	Short circuit
00002000	
00004000	Mains phase loss
00008000	AMA not OK
00010000	Live zero error
00020000	Internal fault
00040000	
00080000	Motor phase U is missing
00100000	Motor phase V is missing
00200000	Motor phase W is missing
00800000	Control Voltage Fault
01000000	
02000000	VDD, supply low
04000000	Brake resistor short circuit
08000000	Brake chopper fault
10000000	Earth fault DESAT
20000000	Drive initialised
40000000	Safe Stop [A68]
80000000	

Table 9.37 16-90 Alarm Word

Bit (Hex)	Alarm Word 2 (16-91 Alarm Word 2)
00000001	
00000002	Reserved
00000004	Service Trip, Typecode / Sparepart
00000008	Reserved
00000010	Reserved
00000020	
00000040	
00000080	
00000100	Broken Belt
00000200	Not used
00000400	Not used
00000800	Reserved
00001000	Reserved
00002000	Reserved
00004000	Reserved
00008000	Reserved
00010000	Reserved
00020000	Not used
00040000	Fans error
00080000	ECB error
00100000	Reserved
00200000	Reserved
00400000	Reserved
00800000	Reserved
01000000	Reserved
02000000	Reserved
04000000	Reserved
08000000	Reserved
10000000	Reserved
20000000	Reserved
40000000	PTC 1 Safe Stop [A71]
80000000	Dangerous Failure [A72]

Table 9.38 16-91 Alarm Word 2



### 9.7.2 Warning Words

Bit (Hex)	Warning Word (16-92 Warning Word)
00000001	
00000002	Power card over temperature
00000004	Earth fault
00000008	
00000010	Control word timeout
00000020	Over current
00000040	
00000080	Motor thermistor over temp.
00000100	Motor ETR over temperature
00000200	Inverter overloaded
00000400	DC link under voltage
00000800	DC link over voltage
00001000	
00002000	
00004000	Mains phase loss
00008000	No motor
00010000	Live zero error
00020000	
00040000	
00080000	
00100000	
00200000	
00400000	
00800000	
01000000	
02000000	Current limit
04000000	
08000000	
10000000	
20000000	
40000000	Safe Stop [W68]
80000000	Not used

Table 9.39 16-92 Warning Word

Bit (Hex)	Warning Word 2 (16-93 Warning Word 2)
00000001	
00000002	
00000004	Clock Failure
00000008	Reserved
00000010	Reserved
00000020	
00000040	
00000080	End of Curve
00000100	Broken Belt
00000200	Not used
00000400	Reserved
00000800	Reserved
00001000	Reserved
00002000	Reserved
00004000	Reserved
00008000	Reserved
00010000	Reserved
00020000	Not used
00040000	Fans warning
00080000	
00100000	Reserved
00200000	Reserved
00400000	Reserved
00800000	Reserved
01000000	Reserved
02000000	Reserved
04000000	Reserved
08000000	Reserved
10000000	Reserved
20000000	Reserved
40000000	PTC 1 Safe Stop [W71]
80000000	Reserved

Table 9.40 16-93 Warning Word 2

## 9.7.3 Extended Status Words

Bit (Hex)	Extended Status Word (16-94 Ext. Status Word)
00000001	Ramping
00000002	AMA tuning
00000004	Start CW/CCW
00000008	Not used
00000010	Not used
00000020	Feedback high
00000040	Feedback low
00000080	Output current high
00000100	Output current low
00000200	Output frequency high
00000400	Output frequency low
00000800	Brake check OK
00001000	Braking max
00002000	Braking
00004000	Out of speed range
00008000	OVC active
00010000	AC brake
00020000	Password Timelock
00040000	Password Protection
00080000	Reference high
00100000	Reference low
00200000	Local Ref./Remote Ref.
00400000	Reserved
00800000	Reserved
01000000	Reserved
02000000	Reserved
04000000	Reserved
08000000	Reserved
10000000	Reserved
20000000	Reserved
40000000	Reserved
80000000	Reserved

Table 9.41 Extended Status Word, 16-94 Ext. Status Word

Bit (Hex)	Extended Status Word 2 (16-95 Ext. Status Word 2)
00000001	Off
00000002	Hand / Auto
00000004	Not used
00000008	Not used
00000010	Not used
00000020	Relay 123 active
00000040	Start Prevented
00000080	Control ready
00000100	Drive ready
00000200	Quick Stop
00000400	DC Brake
00000800	Stop
00001000	Standby
00002000	Freeze Output Request
00004000	Freeze Output
00008000	Jog Request
00010000	Jog
00020000	Start Request
00040000	Start
00080000	Start Applied
00100000	Start Delay
00200000	Sleep
00400000	Sleep Boost
00800000	Running
01000000	Bypass
02000000	Fire Mode
04000000	Reserved
08000000	Reserved
10000000	Reserved
20000000	Reserved
40000000	Reserved
80000000	Reserved

Table 9.42 Extended Status Word 2, 16-95 Ext. Status Word 2

The warning/alarm information below defines each warning/alarm condition, provides the probable cause for the condition, and details a remedy or troubleshooting procedure.

#### **WARNING 1, 10 Volts low**

The control card voltage is below 10 V from terminal 50. Remove some of the load from terminal 50, as the 10 V supply is overloaded. Max. 15 mA or minimum 590  $\Omega$ .

A short circuit in a connected potentiometer or improper wiring of the potentiometer can cause this condition.

##### **Troubleshooting**

Remove the wiring from terminal 50. If the warning clears, the problem is with the wiring. If the warning does not clear, replace the control card.

#### **WARNING/ALARM 2, Live zero error**

This warning or alarm only appears if programmed in *6-01 Live Zero Timeout Function*. The signal on one of the analog inputs is less than 50% of the minimum value programmed for that input. Broken wiring or faulty device sending the signal can cause this condition.

##### **Troubleshooting**

Check connections on all the analog input terminals. Control card terminals 53 and 54 for signals, terminal 55 common. MCB 101 terminals 11 and 12 for signals, terminal 10 common. MCB 109 terminals 1, 3, 5 for signals, terminals 2, 4, 6 common).

Check that the frequency converter programming and switch settings match the analog signal type.

Perform Input Terminal Signal Test.

#### **WARNING/ALARM 4, Mains phase loss**

A phase is missing on the supply side, or the mains voltage imbalance is too high. This message also appears for a fault in the input rectifier on the frequency converter. Options are programmed at *14-12 Function at Mains Imbalance*.

##### **Troubleshooting**

Check the supply voltage and supply currents to the frequency converter.

#### **WARNING 5, DC link voltage high**

The intermediate circuit voltage (DC) is higher than the high-voltage warning limit. The limit is dependent on the frequency converter voltage rating. The unit is still active.

#### **WARNING 6, DC link voltage low**

The intermediate circuit voltage (DC) is lower than the low-voltage warning limit. The limit is dependent on the frequency converter voltage rating. The unit is still active.

#### **WARNING/ALARM 7, DC overvoltage**

If the intermediate circuit voltage exceeds the limit, the frequency converter trips after a time.

#### **Troubleshooting**

Connect a brake resistor

Extend the ramp time

Change the ramp type

Activate the functions in *2-10 Brake Function*

Increase *14-26 Trip Delay at Inverter Fault*

If the alarm/warning occurs during a power sag, use kinetic back-up (*14-10 Mains Failure*)

#### **WARNING/ALARM 8, DC under voltage**

If the DC-link voltage drops below the undervoltage limit, the frequency converter checks if a 24 V DC back-up supply is connected. If no 24 V DC back-up supply is connected, the frequency converter trips after a fixed time delay. The time delay varies with unit size.

##### **Troubleshooting**

Check that the supply voltage matches the frequency converter voltage.

Perform input voltage test.

Perform soft charge circuit test.

#### **WARNING/ALARM 9, Inverter overload**

The frequency converter is about to cut out because of an overload (too high current for too long). The counter for electronic, thermal inverter protection issues a warning at 98% and trips at 100%, while giving an alarm. The frequency converter *cannot* be reset until the counter is below 90%.

The fault is that the frequency converter has run with more than 100% overload for too long.

##### **Troubleshooting**

Compare the output current shown on the LCP with the frequency converter rated current.

Compare the output current shown on the LCP with measured motor current.

Display the Thermal Drive Load on the LCP and monitor the value. When running above the frequency converter continuous current rating, the counter increases. When running below the frequency converter continuous current rating, the counter decreases.

#### **WARNING/ALARM 10, Motor overload temperature**

According to the electronic thermal protection (ETR), the motor is too hot. Select whether the frequency converter issues a warning or an alarm when the counter reaches 100% in *1-90 Motor Thermal Protection*. The fault occurs when the motor runs with more than 100% overload for too long.

##### **Troubleshooting**

Check for motor overheating.

Check if the motor is mechanically overloaded

Check that the motor current set in *1-24 Motor Current* is correct.

Ensure that Motor data in parameters 1-20 to 1-25 are set correctly.

If an external fan is in use, check in *1-91 Motor External Fan* that it is selected.

Running AMA in *1-29 Automatic Motor Adaptation (AMA)* tunes the frequency converter to the motor more accurately and reduces thermal loading.

#### **WARNING/ALARM 11, Motor thermistor over temp**

Check whether the thermistor is disconnected. Select whether the frequency converter issues a warning or an alarm in *1-90 Motor Thermal Protection*.

##### **Troubleshooting**

Check for motor overheating.

Check if the motor is mechanically overloaded.

When using terminal 53 or 54, check that the thermistor is connected correctly between either terminal 53 or 54 (analog voltage input) and terminal 50 (+10 V supply). Also check that the terminal switch for 53 or 54 is set for voltage. Check *1-93 Thermistor Source* selects terminal 53 or 54.

When using digital inputs 18 or 19, check that the thermistor is connected correctly between either terminal 18 or 19 (digital input PNP only) and terminal 50. Check *1-93 Thermistor Source* selects terminal 18 or 19.

#### **WARNING/ALARM 12, Torque limit**

The torque has exceeded the value in *4-16 Torque Limit Motor Mode* or the value in *4-17 Torque Limit Generator Mode*. *14-25 Trip Delay at Torque Limit* can change this warning from a warning-only condition to a warning followed by an alarm.

##### **Troubleshooting**

If the motor torque limit is exceeded during ramp up, extend the ramp up time.

If the generator torque limit is exceeded during ramp down, extend the ramp down time.

If torque limit occurs while running, possibly increase the torque limit. Make sure that the system can operate safely at a higher torque.

Check the application for excessive current draw on the motor.

#### **WARNING/ALARM 13, Over current**

The inverter peak current limit (approximately 200% of the rated current) is exceeded. The warning lasts about 1.5 s, then the frequency converter trips and issues an alarm. Shock loading or quick acceleration with high inertia loads can cause this fault. If the acceleration during ramp up is quick, the fault can also appear after kinetic back-up. If extended mechanical brake control is selected, trip can be reset externally.

##### **Troubleshooting**

Remove power and check if the motor shaft can be turned.

Check that the motor size matches the frequency converter.

Check parameters 1-20 to 1-25 for correct motor data.

#### **ALARM 14, Earth (ground) fault**

There is current from the output phases to ground, either in the cable between the frequency converter and the motor or in the motor itself.

##### **Troubleshooting**

Remove power to the frequency converter and repair the earth fault.

Check for earth faults in the motor by measuring the resistance to ground of the motor leads and the motor with a megohmmeter.

#### **ALARM 15, Hardware mismatch**

A fitted option is not operational with the present control board hardware or software.

Record the value of the following parameters and contact your Danfoss supplier:

*15-40 FC Type*

*15-41 Power Section*

*15-42 Voltage*

*15-43 Software Version*

*15-45 Actual Typecode String*

*15-49 SW ID Control Card*

*15-50 SW ID Power Card*

*15-60 Option Mounted*

*15-61 Option SW Version* (for each option slot)

#### **ALARM 16, Short circuit**

There is short-circuiting in the motor or motor wiring.

Remove power to the frequency converter and repair the short circuit.

#### **WARNING/ALARM 17, Control word timeout**

There is no communication to the frequency converter.

The warning is only active when *8-04 Control Word Timeout Function* is NOT set to [0] Off.

If *8-04 Control Word Timeout Function* is set to [5] Stop and Trip, a warning appears and the frequency converter ramps down until it stops then displays an alarm.

##### **Troubleshooting**

Check connections on the serial communication cable.

Increase *8-03 Control Word Timeout Time*

Check the operation of the communication equipment.

Verify a proper installation based on EMC requirements.

#### **ALARM 18, Start failed**

The speed has not been able to exceed *1-77 Compressor Start Max Speed [RPM]* during start within the allowed time. (set in *1-79 Compressor Start Max Time to Trip*). This may be caused by a blocked motor.

#### **WARNING 23, Internal fan fault**

The fan warning function is an extra protective function that checks if the fan is running/mounted. The fan warning can be disabled in *14-53 Fan Monitor ([0] Disabled)*.

For the D, E, and F Frame filters, the regulated voltage to the fans is monitored.

#### **Troubleshooting**

Check for proper fan operation.

Cycle power to the frequency converter and check that the fan operates briefly at start-up.

Check the sensors on the heatsink and control card.

#### **WARNING 24, External fan fault**

The fan warning function is an extra protective function that checks if the fan is running/mounted. The fan warning can be disabled in *14-53 Fan Monitor ([0] Disabled)*.

#### **Troubleshooting**

Check for proper fan operation.

Cycle power to the frequency converter and check that the fan operates briefly at start-up.

Check the sensors on the heatsink and control card.

#### **WARNING 25, Brake resistor short circuit**

The brake resistor is monitored during operation. If a short circuit occurs, the brake function is disabled and the warning appears. The frequency converter is still operational, but without the brake function. Remove power to the frequency converter and replace the brake resistor (see *2-15 Brake Check*).

#### **WARNING/ALARM 26, Brake resistor power limit**

The power transmitted to the brake resistor is calculated as a mean value over the last 120 seconds of run time. The calculation is based on the intermediate circuit voltage and the brake resistance value set in *2-16 AC brake Max. Current*. The warning is active when the dissipated braking power is higher than 90% of the brake resistance power. If *[2] Trip* is selected in *2-13 Brake Power Monitoring*, the frequency converter trips when the dissipated braking power reaches 100%.

#### **WARNING/ALARM 27, Brake chopper fault**

The brake transistor is monitored during operation and if a short circuit occurs, the brake function is disabled and a warning is issued. The frequency converter is still operational but, since the brake transistor has short-circuited, substantial power is transmitted to the brake resistor, even if it is inactive.

Remove power to the frequency converter and remove the brake resistor.

#### **WARNING/ALARM 28, Brake check failed**

The brake resistor is not connected or not working. Check *2-15 Brake Check*.

#### **ALARM 29, Heatsink temp**

The maximum temperature of the heatsink has been exceeded. The temperature fault does not reset until the temperature falls below a defined heatsink temperature. The trip and reset points are different based on the frequency converter power size.

#### **Troubleshooting**

Check for the following conditions.

Ambient temperature too high.

Motor cable too long.

Incorrect airflow clearance above and below the frequency converter.

Blocked airflow around the frequency converter.

Damaged heatsink fan.

Dirty heatsink.

#### **ALARM 30, Motor phase U missing**

Motor phase U between the frequency converter and the motor is missing.

Remove power from the frequency converter and check motor phase U.

#### **ALARM 31, Motor phase V missing**

Motor phase V between the frequency converter and the motor is missing.

Remove power from the frequency converter and check motor phase V.

#### **ALARM 32, Motor phase W missing**

Motor phase W between the frequency converter and the motor is missing.

Remove power from the frequency converter and check motor phase W.

#### **ALARM 33, Inrush fault**

Too many power-ups have occurred within a short time period. Let the unit cool to operating temperature.

#### **WARNING/ALARM 34, Fieldbus communication fault**

The fieldbus on the communication option card is not working.

#### **WARNING/ALARM 36, Mains failure**

This warning/alarm is only active if the supply voltage to the frequency converter is lost and *14-10 Mains Failure* is NOT set to *[0] No Function*. Check the fuses to the frequency converter and mains supply to the unit.

#### **ALARM 38, Internal fault**

When an internal fault occurs, a code number defined in *Table 9.43* is displayed.

## Troubleshooting

Cycle power

Check that the option is properly installed

Check for loose or missing wiring

It may be necessary to contact your Danfoss supplier or service department. Note the code number for further troubleshooting directions.

No.	Text
0	Serial port cannot be initialised. Contact your Danfoss supplier or Danfoss Service Department.
256-258	Power EEPROM data is defective or too old. Replace power card.
512-519	Internal fault. Contact your Danfoss supplier or Danfoss Service Department.
783	Parameter value outside of min/max limits
1024-1284	Internal fault. Contact your Danfoss supplier or the Danfoss Service Department.
1299	Option SW in slot A is too old
1300	Option SW in slot B is too old
1302	Option SW in slot C1 is too old
1315	Option SW in slot A is not supported (not allowed)
1316	Option SW in slot B is not supported (not allowed)
1318	Option SW in slot C1 is not supported (not allowed)
1379-2819	Internal fault. Contact your Danfoss supplier or Danfoss Service Department.
1792	HW reset of DSP
1793	Motor derived parameters not transferred correctly to DSP
1794	Power data not transferred correctly at power up to DSP
1795	The DSP has received too many unknown SPI telegrams
1796	RAM copy error
2561	Replace control card
2820	LCP stack overflow
2821	Serial port overflow
2822	USB port overflow
3072-5122	Parameter value is outside its limits
5123	Option in slot A: Hardware incompatible with control board hardware
5124	Option in slot B: Hardware incompatible with control board hardware
5125	Option in slot C0: Hardware incompatible with control board hardware
5126	Option in slot C1: Hardware incompatible with control board hardware
5376-6231	Internal fault. Contact your Danfoss supplier or Danfoss Service Department.

Table 9.43 Internal Fault Codes

### ALARM 39, Heatsink sensor

No feedback from the heat sink temperature sensor.

The signal from the IGBT thermal sensor is not available on the power card. The problem could be on the power card, on the gate drive card, or the ribbon cable between the power card and gate drive card.

### WARNING 40, Overload of digital output terminal 27

Check the load connected to terminal 27 or remove short-circuit connection. Check *5-00 Digital I/O Mode* and *5-01 Terminal 27 Mode*.

### WARNING 41, Overload of digital output terminal 29

Check the load connected to terminal 29 or remove short-circuit connection. Check *5-00 Digital I/O Mode* and *5-02 Terminal 29 Mode*.

### WARNING 42, Overload of digital output on X30/6 or overload of digital output on X30/7

For X30/6, check the load connected to X30/6 or remove the short-circuit connection. Check *5-32 Term X30/6 Digi Out (MCB 101)*.

For X30/7, check the load connected to X30/7 or remove the short-circuit connection. Check *5-33 Term X30/7 Digi Out (MCB 101)*.

### ALARM 45, Earth fault 2

Ground fault.

#### Troubleshooting

Check for proper grounding and loose connections.

Check for proper wire size.

Check motor cables for short-circuits or leakage currents.

### ALARM 46, Power card supply

The supply on the power card is out of range.

There are 3 power supplies generated by the switch mode power supply (SMPS) on the power card: 24 V, 5 V,  $\pm 18$  V. When powered with 24 V DC with the MCB 107 option, only the 24 V and 5 V supplies are monitored. When powered with 3-phase mains voltage, all 3 supplies are monitored.

#### Troubleshooting

Check for a defective power card.

Check for a defective control card.

Check for a defective option card.

If a 24 V DC power supply is used, verify proper supply power.

### WARNING 47, 24 V supply low

The 24 V DC is measured on the control card. The external 24 V DC back-up power supply may be overloaded, otherwise contact the Danfoss supplier.

### WARNING 48, 1.8 V supply low

The 1.8 V DC supply used on the control card is outside of allowable limits. The power supply is measured on the control card. Check for a defective control card. If an option card is present, check for an overvoltage condition.

**WARNING 49, Speed limit**

When the speed is not within the specified range in *4-11 Motor Speed Low Limit [RPM]* and *4-13 Motor Speed High Limit [RPM]*, the frequency converter shows a warning. When the speed is below the specified limit in *1-86 Trip Speed Low [RPM]* (except when starting or stopping), the frequency converter trips.

**ALARM 50, AMA calibration failed**

Contact your Danfoss supplier or Danfoss Service Department.

**ALARM 51, AMA check  $U_{nom}$  and  $I_{nom}$** 

The settings for motor voltage, motor current and motor power are wrong. Check the settings in parameters 1-20 to 1-25.

**ALARM 52, AMA low  $I_{nom}$** 

The motor current is too low. Check the settings.

**ALARM 53, AMA motor too big**

The motor is too big for the AMA to operate.

**ALARM 54, AMA motor too small**

The motor is too small for the AMA to operate.

**ALARM 55, AMA parameter out of range**

The parameter values of the motor are outside of the acceptable range. AMA cannot run.

**ALARM 56, AMA interrupted by user**

The user has interrupted the AMA.

**ALARM 57, AMA internal fault**

Try to restart AMA again. Repeated restarts can over heat the motor.

**ALARM 58, AMA Internal fault**

Contact your Danfoss supplier.

**WARNING 59, Current limit**

The current is higher than the value in *4-18 Current Limit*. Ensure that Motor data in parameters 1-20 to 1-25 are set correctly. Possibly increase the current limit. Be sure that the system can operate safely at a higher limit.

**WARNING 60, External interlock**

A digital input signal is indicating a fault condition external to the frequency converter. An external interlock has commanded the frequency converter to trip. Clear the external fault condition. To resume normal operation, apply 24 V DC to the terminal programmed for external interlock. Reset the frequency converter.

**WARNING 62, Output frequency at maximum limit**

The output frequency has reached the value set in *4-19 Max Output Frequency*. Check the application to determine the cause. Possibly increase the output frequency limit. Be sure the system can operate safely at a higher output frequency. The warning will clear when the output drops below the maximum limit.

**WARNING/ALARM 65, Control card over temperature**

The cut-out temperature of the control card is 80 °C.

**Troubleshooting**

- Check that the ambient operating temperature is within limits
- Check for clogged filters
- Check fan operation
- Check the control card

**WARNING 66, Heatsink temperature low**

The frequency converter is too cold to operate. This warning is based on the temperature sensor in the IGBT module.

Increase the ambient temperature of the unit. Also, a trickle amount of current can be supplied to the frequency converter whenever the motor is stopped by setting *2-00 DC Hold/Preheat Current* at 5% and *1-80 Function at Stop*

**ALARM 67, Option module configuration has changed**

One or more options have either been added or removed since the last power-down. Check that the configuration change is intentional and reset the unit.

**ALARM 68, Safe Stop activated**

Safe Torque Off has been activated. To resume normal operation, apply 24 V DC to terminal 37, then send a reset signal (via bus, digital I/O, or by pressing [Reset]).

**ALARM 69, Power card temperature**

The temperature sensor on the power card is either too hot or too cold.

**Troubleshooting**

- Check that the ambient operating temperature is within limits.
- Check for clogged filters.
- Check fan operation.
- Check the power card.

**ALARM 70, Illegal FC configuration**

The control card and power card are incompatible. To check compatibility, contact your supplier with the type code of the unit from the nameplate and the part numbers of the cards.

**ALARM 71, PTC 1 safe stop**

Safe Torque Off has been activated from the PTC Thermistor Card MCB 112 (motor too warm). Normal operation can be resumed when the MCB 112 applies 24 V DC to Terminal 37 again (when the motor temperature reaches an acceptable level) and when the Digital Input from the MCB 112 is deactivated. When that happens, a reset signal must be sent (via Bus, Digital I/O, or by pressing [Reset]).

**ALARM 72, Dangerous failure**

Safe Torque Off with trip lock. An unexpected combination of Safe Torque Off commands has occurred:

- MCB 112 VLT PTC Thermistor Card enables X44/10, but safe stop is not enabled.
- MCB 112 is the only device using Safe Torque Off (specified through selection [4] or [5] in *5-19 Terminal 37 Safe Stop*), Safe Torque Off is activated, and X44/10 is not activated.

**ALARM 80, Drive initialised to default value**

Parameter settings are initialised to default settings after a manual reset. To clear the alarm, reset the unit.

**ALARM 92, No flow**

A no-flow condition has been detected in the system. *22-23 No-Flow Function* is set for alarm. Troubleshoot the system and reset the frequency converter after the fault has been cleared.

**ALARM 93, Dry pump**

A no-flow condition in the system with the frequency converter operating at high speed may indicate a dry pump. *22-26 Dry Pump Function* is set for alarm. Troubleshoot the system and reset the frequency converter after the fault has been cleared.

**ALARM 94, End of curve**

Feedback is lower than the set point. This may indicate leakage in the system. *22-50 End of Curve Function* is set for alarm. Troubleshoot the system and reset the frequency converter after the fault has been cleared.

**ALARM 95, Broken belt**

Torque is below the torque level set for no load, indicating a broken belt. *22-60 Broken Belt Function* is set for alarm. Troubleshoot the system and reset the frequency converter after the fault has been cleared.

**ALARM 96, Start delayed**

Motor start has been delayed due to short-cycle protection. *22-76 Interval between Starts* is enabled. Troubleshoot the system and reset the frequency converter after the fault has been cleared.

**WARNING 97, Stop delayed**

Stopping the motor has been delayed due to short cycle protection. *22-76 Interval between Starts* is enabled. Troubleshoot the system and reset the frequency converter after the fault has been cleared.

**WARNING 98, Clock fault**

Time is not set or the RTC clock has failed. Reset the clock in *0-70 Date and Time*.

**WARNING 200, Fire mode**

This warning indicates the frequency converter is operating in fire mode. The warning clears when fire mode is removed. See the fire mode data in the alarm log.

**WARNING 201, Fire mode was active**

This indicates the frequency converter had entered fire mode. Cycle power to the unit to remove the warning. See the fire mode data in the alarm log.

**WARNING 202, Fire mode limits exceeded**

While operating in fire mode one or more alarm conditions have been ignored which would normally trip the unit. Operating in this condition voids unit warranty. Cycle power to the unit to remove the warning. See the fire mode data in the alarm log.

**WARNING 203, Missing motor**

With a frequency converter operating multi-motors, an under-load condition was detected. This could indicate a missing motor. Inspect the system for proper operation.

**WARNING 204, Locked rotor**

With a frequency converter operating multi-motors, an overload condition was detected. This could indicate a locked rotor. Inspect the motor for proper operation.

**WARNING 250, New spare part**

A component in the frequency converter has been replaced. Reset the frequency converter for normal operation.

**WARNING 251, New typecode**

The power card or other components have been replaced and the typecode changed. Reset to remove the warning and resume normal operation.



**Index**

**A**

Abbreviations..... 7

Access to Control Terminals..... 108

Accessory Bags..... 80

Acoustic Noise..... 160

Advanced Vector Control..... 9

Aggressive Environments..... 13

Air Humidity..... 13

Alarm Words..... 174

Alarm/Warning Code List..... 172

Alarms and Warnings..... 170

AMA..... 120, 123, 178, 181

Analog I/O option MCB 109..... 57

Analog I/O selection..... 57

Analog input..... 177

Analog inputs..... 8, 157

Analog Inputs..... 9

Analog output..... 157

Analog Outputs - Terminal X30/5+8..... 53

Analog signal..... 177

Analog Voltage Inputs - Terminal X30/10-12..... 53

Application Examples..... 24

Automatic Adaptations to Ensure Performance..... 169

Automatic Motor Adaptation..... 123

Automatic Motor Adaptation (AMA)..... 120

AWG..... 147

**B**

BACnet..... 68

Balancing contractor..... 30

Basic Wiring Example..... 111

Battery back-up of clock function..... 57

Better Control..... 22

Brake Function..... 48

Brake power..... 9, 49

Brake Resistor..... 47

Brake Resistor Cabling..... 49

Brake Resistor Calculation..... 48

Brake Resistors..... 76

Braking..... 179

Branch Circuit Protection..... 95

Break-away torque..... 8

Building Management System..... 57

Building Management System, BMS..... 21

Bypass frequency ranges..... 27

**C**

Cable clamps..... 117

Cable Lengths and Cross Sections..... 156

Caution..... 11

CAV system..... 26

CE Conformity and Labelling..... 12

Central VAV systems..... 25

Clockwise rotation..... 107

Closed Loop Control for a Ventilation System..... 39

CO2 sensor..... 26

Coasting..... 8, 144, 145

Communication option..... 179

Comparison of Energy Savings..... 21

Condenser Pumps..... 29

Conducted emission..... 0, 43

Constant Air Volume..... 26

Constant torque applications (CT mode)..... 169

Control cables..... 117, 119

Control Cables..... 112

Control card..... 177

Control Card performance..... 159

Control card, 10 V DC output..... 158

Control Card, 24 V DC output..... 158

Control card, RS-485 serial communication..... 157

Control card, USB serial communication..... 159

Control characteristics..... 158

Control potential..... 32

Control Structure Closed Loop..... 35

Control Structure Open Loop..... 33

Control Terminals..... 109, 110

Control word..... 144

Cooling..... 169

Cooling conditions..... 81

Cooling Tower Fan..... 27

Copyright, Limitation of Liability and Revision Rights..... 6

Cos  $\varphi$  Compensation..... 22

Current rating..... 177

**D**

Dampers..... 25

Data Types Supported by the Frequency Converter..... 135

DC brake..... 144

DC Bus Connection..... 114

DC-link..... 177

Decoupling plate.....	87	Front cover tightening torque.....	79
Definitions.....	8	Function Codes.....	140
Derating for Ambient Temperature.....	164	Fuses.....	95, 179
Derating for Low Air Pressure.....	169		
Derating for Running at Low Speed.....	169	<b>G</b>	
DeviceNet.....	68	General Aspects of Harmonics Emission.....	44
Differential pressure.....	32	General Specifications.....	156
Digital input.....	178	Ground leakage current.....	116
Digital inputs.....	156	Ground loops.....	119
Digital Inputs - Terminal X30/1-4.....	53	Grounding.....	87, 116
Digital Output.....	158		
Digital Outputs - Terminal X30/5-7.....	53	<b>H</b>	
Direction of motor rotation.....	107	Harmonic filters.....	69
Discharge Time.....	12	Harmonics Emission Requirements.....	44
Disposal Instruction.....	12	Harmonics Test Results (Emission).....	44
Drive Configurator.....	65	High Voltage Test.....	115
DU/dt filters.....	64	Hold output frequency.....	144
<b>E</b>		<b>I</b>	
Efficiency.....	160	I/Os for set point inputs.....	57
Electrical Installation.....	110, 112	IGVs.....	25
Electrical Installation - EMC Precautions.....	116	Immunity Requirements.....	45
EMC Directive 2004/108/EC.....	13	Index (IND).....	134
EMC emissions.....	41	Input terminal.....	177
EMC Precautions.....	131	Installation at high altitudes.....	11
EMC Test Results.....	43	Installation of 24 V external DC Supply.....	109
EMC-Correct Cables.....	118	Intermediate circuit.....	49, 160, 161
Emission Requirements.....	42	IP21/IP41/ TYPE1 Enclosure Kit.....	62
Energy Savings.....	20, 22	IP21/Type 1 Enclosure Kit.....	62
ETR.....	107	IT mains.....	119
Evaporator flow rate.....	30		
Example of Closed Loop PID Control.....	39	<b>J</b>	
Extended Status Word.....	176	Jog.....	8, 145
Extended Status Word 2.....	176		
External 24 V DC supply.....	56	<b>K</b>	
Extreme Running Conditions.....	49	Knockouts.....	84
<b>F</b>		<b>L</b>	
Fan System Controlled by Frequency Converters.....	23	Laws of proportionality.....	21
FC with Modbus RTU.....	132	LCP.....	8, 9, 35, 61
Feedback.....	180, 182	Lead Pump Alternation Wiring Diagram.....	127
Fieldbus connection.....	108	Literature.....	6
Flow meter.....	30	Load Sharing.....	114
Freeze output.....	8	Local (Hand On) and Remote (Auto On) Control.....	35
Frequency Converter Hardware Setup.....	130	Local speed determination.....	30
Frequency Converter Set-up.....	132	Low evaporator temperature.....	30

**M**

Mains Disconnectors.....	104
Mains Drop-out.....	50
Mains supply.....	10
Mains Supply.....	147, 151
Manual PID Adjustment.....	40
MCT 31.....	115
Mechanical Dimensions.....	78
Mechanical Mounting.....	81
Modbus Communication.....	131
Modbus Exception Codes.....	140
Modbus RTU.....	137
Moment of inertia.....	49
Motor Cable.....	104
Motor cables.....	117
Motor Connection.....	86
Motor current.....	181
Motor data.....	178, 181
Motor name plate.....	120
Motor output.....	156
Motor parameters.....	123
Motor phases.....	49
Motor power.....	181
Motor protection.....	107, 160
Motor Rotation.....	107
Motor thermal protection.....	146
Motor Thermal Protection.....	50, 105
Motor voltage.....	161
Motor-generated Over-voltage.....	49
Multiple pumps.....	32
Multi-zone control.....	57

**N**

Name plate data.....	120
Network Connection.....	130
Ni1000 temperature sensor.....	57

**O**

Option.....	54
Options and Accessories.....	52
Ordering numbers.....	65
Ordering Numbers.....	73, 74, 75, 76
Ordering Numbers: Harmonic Filters.....	69
Ordering Numbers: Options and Accessories.....	67
Output current.....	177

Output Filters.....	64
Output Performance (U, V, W).....	156
Outputs for actuators.....	57

**P**

Parameter Number (PNU).....	134
Parameter Values.....	141
Pay back period.....	22
Peak Voltage on Motor.....	161
Phase loss.....	177
Potentiometer Reference.....	123
Power Factor.....	10
Power factor correction.....	22
Primary Pumps.....	30
Principle Diagram.....	57
Profibus.....	68
Programmable minimum frequency setting.....	27
Programming.....	177
Programming Order.....	39
Protection.....	13, 46
Protection and features.....	160
Protocol Overview.....	131
Pt1000 temperature sensor.....	57
Public supply network.....	44
Pulse Inputs.....	157
Pulse Start/Stop.....	122
Pump impeller.....	29

**R**

Radiated emission.....	0 , 43
Rated motor speed.....	8
RCD.....	9
Read Holding Registers (03 HEX).....	142
Real-time clock (RTC).....	58
Reference Handling.....	38
Relay Connection.....	94
Relay Option.....	54
Relay Outputs.....	158
Reset.....	177, 182
Residual Current Device.....	120
Return fan.....	25
RFI Switch.....	119
Rise time.....	161
RS-485.....	130

S

Safe Torque Off..... 14

Safety Ground Connection..... 116

Safety Note..... 11

Safety Regulations..... 11

Safety requirement..... 77

Screened Control Cables..... 119

Screened/armoured..... 86, 113

Secondary Pumps..... 32

Serial communication..... 119, 159

Serial communication port..... 8

Shock..... 14

Short circuit..... 178

Short Circuit (Motor Phase – Phase)..... 49

Side-by-side installation..... 81

Sine-wave filter..... 89

Sine-wave filters..... 64

Smart Logic Control..... 123

Smart Logic Control Programming..... 123

Soft-starter..... 22

Software Version..... 6

Software versions..... 68

Star/Delta Starter..... 22

Start/Stop..... 122

Start/Stop Conditions..... 129

Static Overload in VVCplus mode..... 50

Status Word..... 145

Supply voltage..... 179

Surroundings:..... 159

Switches S201, S202, and S801..... 110

Switching on the Output..... 49

System Status and Operation..... 126

T

Telegram Length (LGE)..... 132

The Clear Advantage - Energy Savings..... 20

The EMC directive (2004/108/EC)..... 12

The low-voltage directive (2006/95/EC)..... 12

The machinery directive (2006/42/EC)..... 12

Thermal Protection..... 6

Thermistor..... 9

Throttling valve..... 29

Torque Characteristics..... 156

Transmitter/sensor inputs..... 57

Troubleshooting..... 170

Tuning the Frequency Converter Closed Loop Controller.... 40

Type Code String Low and Medium Power..... 66

U

USB Connection..... 109

V

Variable (Quadratic) torque applications (VT)..... 170

Variable Air Volume..... 25

Variable control of flow and pressure..... 22

Varying Flow over 1 Year..... 22

VAV..... 25

Vibration..... 14

Vibrations..... 27

Voltage imbalance..... 177

Voltage level..... 157

VVCplus)..... 10

W

Warning against unintended start..... 11

Warning Words..... 175

What is CE Conformity and Labelling?..... 12





[www.danfoss.com/drives](http://www.danfoss.com/drives)

.....  
Danfoss can accept no responsibility for possible errors in catalogues, brochures and other printed material. Danfoss reserves the right to alter its products without notice. This also applies to products already on order provided that such alterations can be made without subsequential changes being necessary in specifications already agreed. All trademarks in this material are property of the respective companies. Danfoss and the Danfoss logotype are trademarks of Danfoss A/S. All rights reserved.  
.....

Danfoss A/S  
Ulsnaes 1  
DK-6300 Graasten  
[www.danfoss.com/drives](http://www.danfoss.com/drives)

