



User Guide

VLT[®] Parallel Drive Modules

250–1200 kW



Contents

1 Introduction	4
1.1 Purpose of the Manual	4
1.2 Additional Resources	4
1.3 Manual and Software Version	4
1.4 Approvals and Certifications	4
1.5 Disposal	4
2 Safety	5
2.1 Safety Symbols	5
2.2 Qualified Personnel	5
2.3 Safety Precautions	5
3 Product Overview	7
3.1 Intended Use	7
3.2 Drive System	7
3.3 Drive Module	11
3.4 Control Shelf	13
4 Commissioning	14
4.1 Safety Instructions	14
4.2 Applying Power	14
4.3 Local Control Panel (LCP)	15
4.3.1 Overview	15
4.3.2 Layout	15
4.3.3 Menus	16
4.4 Programming the Drive System	17
4.4.1 Entering System Information	18
4.4.2 Q3 Function Set-ups	19
4.4.3 Control Terminal Programming	19
4.4.4 Configuring Automatic Energy Optimization	19
4.4.5 Configuring Automatic Motor Adaptation	19
4.5 Testing Before System Startup	20
4.5.1 Motor Rotation	20
4.5.2 Encoder Rotation	20
4.5.3 Local Control Test	20
4.6 System Startup	21
4.7 Parameter Settings	21
4.7.1 Uploading and Downloading Parameter Settings	21
4.7.2 Restoring Factory Default Settings	21

5 Application Set-up Examples	23
5.1 Introduction	23
5.2 Application Examples	23
5.2.1 Automatic Motor Adaptation (AMA)	23
5.2.2 RS485 Network Connection	24
5.2.3 Smart Logic Controller (SLC) Mode	24
5.2.4 Mechanical Brake Control	25
5.2.5 Open Loop Speed Control	25
5.2.6 Start/Stop	27
5.2.7 External Alarm Reset	28
5.2.8 Motor Thermistor	28
5.3 Connection Examples for Control of Motor with External Signal Provider	29
5.3.1 Start/Stop	29
5.3.2 Pulse Start/Stop	29
5.3.3 Speed Up/Down	29
5.3.4 Potentiometer Reference	30
6 Maintenance, Diagnostics, and Troubleshooting	31
6.1 Maintenance and Service	31
6.2 Periodic Maintenance	31
6.3 Status Messages	31
6.4 Warning and Alarm Types	34
6.5 List of Warnings and Alarms	34
6.5.1 Warnings/Alarm Messages	34
6.6 Troubleshooting	48
6.7 Running in Reduced Power Mode	51
6.7.1 Safety	51
6.7.2 Configuring the Drive System for Reduced Power Mode	52
6.7.3 Wiring Configurations	53
7 Specifications	54
7.1 Power-dependent Specifications	54
7.1.1 VLT® HVAC Drive FC 102	54
7.1.2 VLT® AQUA Drive FC 202	58
7.1.3 VLT® AutomationDrive FC 302	63
7.2 Connection Tightening Torques	68
7.3 Fuses and Circuit Breakers	68
7.3.1 Protection	68
7.3.2 Fuse Selection	68
7.3.2.1 Recommended Fuses for CE Compliance	69

7.3.2.2 Recommended Fuses for UL Compliance	70
7.3.3 Fuse Replacement	70
7.3.4 Short Circuit Current Rating (SCCR)	70
8 Appendix	71
8.1 Symbols, Abbreviations, and Conventions	71
8.2 International/North American Default Parameter Settings	72
8.3 Parameter Menu Structure	72
8.3.1 Main Menu Structure	73
Index	77

1 Introduction

1.1 Purpose of the Manual

This manual provides detailed information for startup and commissioning of the drive system composed of VLT® Parallel Drive Modules. *Chapter 4 Commissioning* provides detailed procedures for basic programming, pre-startup testing, and startup.

The remaining chapters provide supplementary details, including:

- The user interface.
- Detailed programming.
- Application examples.
- Operational troubleshooting.
- Specifications.

This user guide is intended for use by qualified personnel.

To operate and maintain the drive system safely and professionally, read and follow the user guide. Pay particular attention to the safety instructions and general warnings. Always keep this user guide with the drive system.

VLT® is a registered trademark.

1.2 Additional Resources

Other resources are available to understand the functions and programming of the VLT® Parallel Drive Modules.

- The *VLT® Parallel Drive Modules 250–1200 kW Design Guide* contains detailed information about the capabilities and functionality of motor control systems using these drive modules, and provides guidance for designing this type of system.
- The *VLT® Parallel Drive Modules 250–1200 kW Installation Guide* provides instructions for mechanical and electrical installation of these drive modules.
- Refer to the FC 102, FC 202, or FC 302 *VLT® Drive Programming Guide* applicable to the particular series of VLT® Parallel Drive Modules used in creating the drive system. The programming guide describes in greater detail how to work with parameters and provides application examples.
- The *VLT® FC Series, D-frame Service Manual* contains detailed service information, including information applicable to the VLT® Parallel Drive Modules.

- The *VLT® Parallel Drive Modules DC Fuses Installation Instructions* contain detailed information about installing the DC fuses.
- The *VLT® Parallel Drive Modules Bus Bar Kit Installation Instructions* contain detailed information about installing the busbar option kit.
- The *VLT® Parallel Drive Modules Duct Kit Installation Instructions* contain detailed information about installing the duct option kit.

Refer to other supplemental publications and manuals, available from Danfoss. See vlt-drives.danfoss.com/support/technical-documentation/ for listings.

1.3 Manual and Software Version

This manual is regularly reviewed and updated. All suggestions for improvement are welcome. *Table 1.1* shows the manual version and the corresponding software version.

Manual version	Remarks	Software version
MG37L2xx	Update to Drive System section	FC 102 (5.0x), FC 202 (3.0x), FC 302 (7.6x)

Table 1.1 Manual and Software Version

1.4 Approvals and Certifications



Table 1.2 Approvals

1.5 Disposal

Do not dispose of equipment containing electrical components together with domestic waste.
Collect it separately in accordance with local and currently valid legislation.

2 Safety

2.1 Safety Symbols

The following symbols are used in this manual:

⚠ WARNING

Indicates a potentially hazardous situation that could result in death or serious injury.

⚠ CAUTION

Indicates a potentially hazardous situation that could result in minor or moderate injury. It can also be used to alert against unsafe practices.

NOTICE

Indicates important information, including situations that can result in damage to equipment or property.

2.2 Qualified Personnel

Correct and reliable operation and maintenance are required for the trouble-free and safe operation of the drive system. Only qualified personnel are allowed to operate and maintain this equipment.

Qualified personnel are defined as persons who are trained and authorized to commission, operate, and maintain equipment, systems, and circuits in accordance with pertinent laws and regulations. Also, the personnel must be familiar with the instructions and safety measures described in this manual.

2.3 Safety Precautions

⚠ WARNING

HIGH VOLTAGE

The drive system contains high voltage when connected to AC mains input. Failure to ensure that only qualified personnel are allowed to operate and maintain the system can result in death or serious injury.

⚠ WARNING

UNINTENDED START

When the drive system is connected to AC mains, the motor can start at any time. Unintended start during programming, service, or repair work can result in death, serious injury, or property damage.

The motor can start via any of the following:

- An external switch.
- A fieldbus command.
- An input reference signal from the LCP.
- A cleared fault condition.
- Remote operation using MCT 10 software.

To prevent unintended motor start:

- Disconnect the drive system from AC mains.
- Press [Off/Reset] on the LCP, before programming parameters.
- The drive system, motor, and any driven equipment must be fully wired and assembled when the drive is connected to AC mains.

⚠ WARNING

DISCHARGE TIME

The drive system contains DC-link capacitors. Once mains power has been applied to the drive system, these capacitors can remain charged even after the power has been removed. High voltage can be present even when the warning indicator lights are off. Failure to wait 20 minutes after power has been removed before performing service or repair work can result in death or serious injury.

- Stop the motor.
- Disconnect AC mains and remote DC-link power supplies, including battery back-ups, UPS, and DC-link connections to other drives.
- Disconnect or lock the PM motor.
- Check the system for an installed external discharge resistor. If a discharge resistor is installed, activate its associated contactor. Before servicing the drive system, use a multimeter to verify that the DC voltage on each drive module is fully discharged.
- If an external discharge resistor is not installed, wait 20 minutes for the capacitors to discharge fully before performing any service or repair work.

⚠ WARNING**LEAKAGE CURRENT HAZARD (>3.5 mA)**

Leakage currents exceed 3.5 mA. Failure to ground the drive system properly can result in death or serious injury. Follow national and local codes regarding protective earthing of equipment with a leakage current >3.5 mA. Frequency converter technology used in the drive system implies high frequency switching at high power. This switching generates a leakage current in the ground connection. A fault current in the drive system at the output power terminals sometimes contains a DC component, which can charge the filter capacitors and cause a transient ground current. The ground leakage current depends on various system configurations including RFI filtering, shielded motor cables, and drive system power.

If the leakage current exceeds 3.5 mA, EN/IEC61800-5-1 (Power Drive System Product Standard) requires special care. Grounding must be reinforced in 1 of the following ways:

- Ensure the correct grounding of the equipment by a certified electrical installer.
- Ground wire of at least 10 mm² (7 AWG).
- Two separate ground wires, both complying with the dimensioning rules.

See EN 60364-5-54 § 543.7 for further information.

⚠ WARNING**EQUIPMENT HAZARD**

Contact with rotating shafts and electrical equipment can result in death or serious injury.

- Ensure that only trained and qualified personnel are allowed to perform startup or maintenance.
- Ensure that electrical work conforms to national and local electrical codes.
- Follow the procedures in this manual.

⚠ CAUTION**INTERNAL FAILURE HAZARD**

Missing or incorrectly placed safety covers in the drive system can result in serious injury.

- Ensure that all safety covers are in place and securely fastened before applying power.

⚠ WARNING**UNINTENDED MOTOR ROTATION
WINDMILLING**

Unintended rotation of permanent magnet motors creates voltage and can charge the capacitors in the drive system, resulting in death, serious injury, or equipment damage.

- Ensure that permanent magnet motors are blocked to prevent unintended rotation.

⚠ WARNING**DISCONNECT POWER BEFORE SERVICING**

Sometimes during installation, AC mains power is applied but then must be disconnected to change the line connections. In that case, disconnect the drive system from the AC mains, 230 V supply, and motor lines. After the lines have been disconnected, wait 30 minutes for the capacitors to discharge. Failure to follow these steps can result in death or serious injury.

3 Product Overview

3.1 Intended Use

A drive system is a type of electronic motor controller that converts AC mains input into a variable AC waveform output. The system then regulates the frequency and voltage of the output to control the motor speed or torque. This drive system is designed by the installer, using the VLT® Parallel Drive Modules basic kit and any selected options kits. The basic kit is composed of 2 or 4 drive modules and connecting hardware, and is UL 508 C compliant.

This drive system can be used in residential, industrial, and commercial environments, in accordance with local laws and standards.

NOTICE

In a residential environment, this product can cause radio interference, in which case supplementary measures may be required to mitigate the interference.

Foreseeable misuse

Do not use the drive system in applications that are not compliant with specified operating conditions and environments. Ensure compliance with the conditions specified in *chapter 7 Specifications*.

3.2 Drive System

The drive system is designed by the installer to meet specified power requirements, using the VLT® Parallel Drive Modules basic kit and any selected options kits. The basic kit consists of connecting hardware and either 2 or 4 drive modules, which are connected in parallel.

NOTICE

Illustration 3.1 shows a system using 4 drive modules. A system using 2 drive modules is similar, except for the connecting hardware. *Illustration 3.1* shows the busbar option kit. The installer can use other connection methods, including locally manufactured busbars or electrical cables. The installer is responsible for the details of the drive system construction, including connections and proper grounding.

3

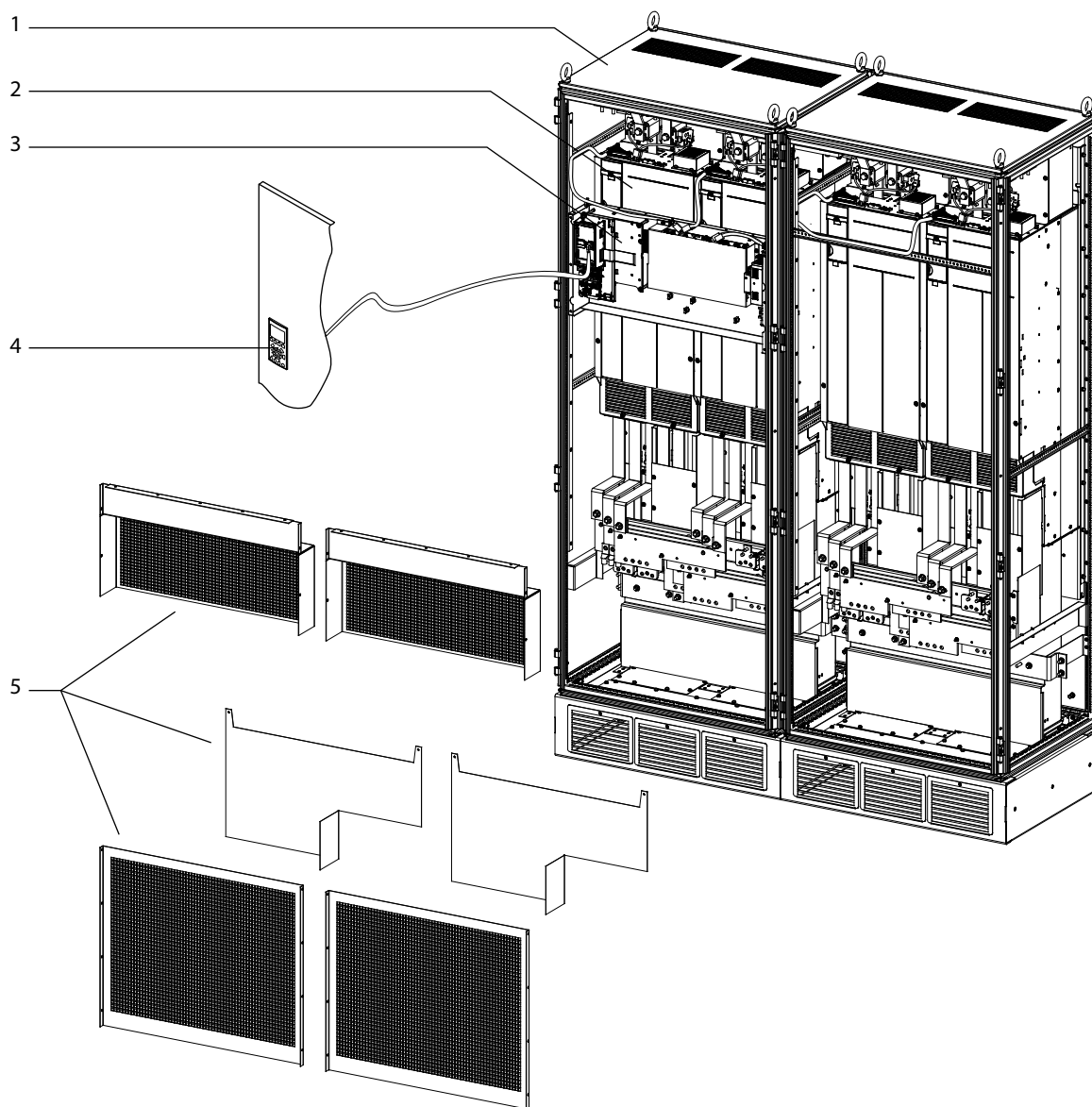

130BE756.10

Area	Title	Functions
1	Cabinet (installer-provided)	Used to house the drive modules and other drive system components.
2	Drive modules	2 or 4 drive modules can be installed in parallel to create a drive system.
3	Control shelf	Consists of an MDCIC (Multi-Drive Control Interface Card), a control card, an LCP, a safety relay, and an SMPS (switched-mode power supply). The MDCIC interfaces the LCP and control card with the power card in each drive module.
4	LCP	The local control module, shown mounted on the cabinet door. Allows the operator to monitor and control the system and motor.
5	Protective shields	In this view EMI/EMC shields and other protective shields are shown removed so that the parts of the drive system can be made visible. Some of these shields reduce EMI/EMC emissions, while other shields provide physical protection against the high-voltage electrical hazard.

Illustration 3.1 Drive System Overview

Components and their functions

Illustration 3.2 provides a functional description of the drive system components. The dashed lines in the diagram represent the option of connecting either 2 or 4 drive modules in parallel.

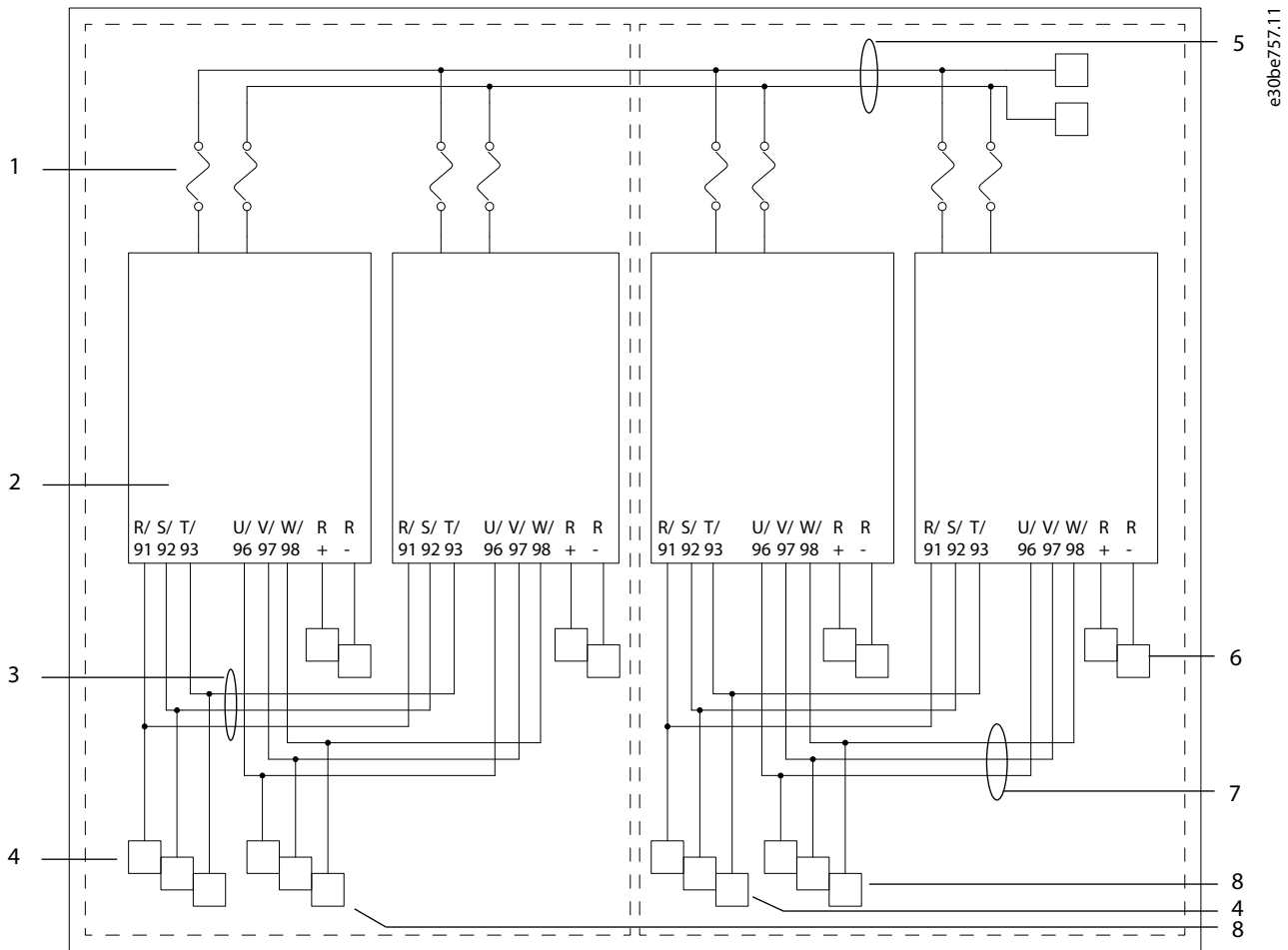

3

Area	Title	Functions
1	DC-link terminals and DC fuses	These terminals allow access to the DC-link and DC fuses on the individual drive modules.
2	Drive modules	This diagram shows a drive system in which 2 drive modules are installed in parallel. In this same fashion, a system can also be constructed with 4 drive modules. See <i>chapter 3.3 Drive Module</i> .
3	Mains input busbars	The input terminals of the individual drive modules are connected to the mains input busbars with the use of flexible busbars. By doing so, the input busbars join the input terminals of the individual drive modules in parallel, and provide a connection for the mains input cables to the drive system. The mains input busbars are part of the busbar kit, which can be ordered from Danfoss as an option. However, the installer may choose to fabricate the busbars locally, or use cables in place of busbars.
4	Mains input	3-phase AC mains power input to the drive system, connected to the mains input busbars. In a system using 4 drive modules, the installer must install line wiring to both sets of mains input busbars.

Area	Title	Functions
5	DC-link busbars	Used to connect the DC-links of the drive modules in parallel. The DC-link busbars are part of the busbar kit, which can be ordered from Danfoss as an option. The kit also includes the required busbar to tie together the 2 sets of DC-link busbars. The installer, however, may choose to fabricate the busbars locally, or use cables in place of busbars.
6	Brake resistor terminals	Terminals used to connect an external brake resistor to the drive module.
7	Motor output busbars	The output terminals of the individual drive modules are connected to the motor output busbars with the use of flexible busbars. By doing so, the output busbars join the output terminals of the individual drive modules in parallel, and provide a connection to the motor cables to supply controlled AC voltage output to the motor. The motor output busbars are part of the busbar kit, which can be ordered from Danfoss as an option. However, the installer may choose to fabricate the busbars locally, or use cables in place of busbars.
8	Motor output	Controlled AC output to the motor. In a system using 4 drive modules, the installer must install an equal number of motor wires to both sets of motor output busbars.

Illustration 3.2 Drive System Block Diagram

3.3 Drive Module

Each drive module has an IP00 protection rating. Either 2 or 4 drive modules can be connected in parallel to create a drive system, based on power requirements. The drive modules are part of the VLT® Parallel Drive Modules basic kit, which also includes the control shelf, DC fuses, and wiring harnesses.

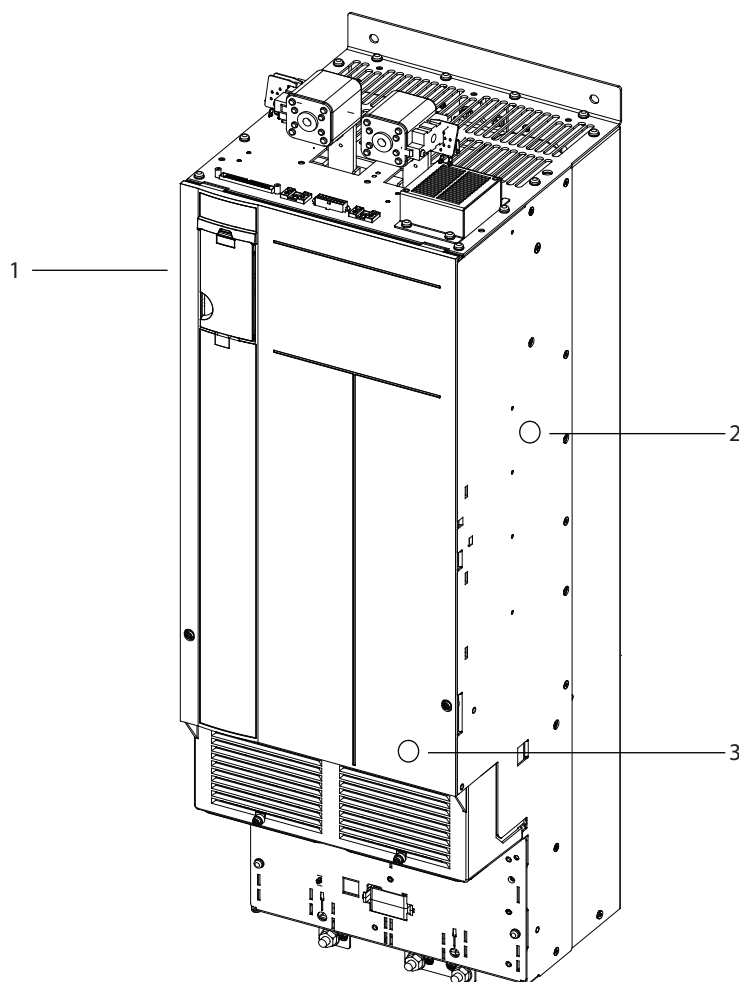

130BE758.10

3

Area	Title	Functions
1	Drive module	2 or 4 drive modules can be used in a drive system, according to the power requirements.
2	Data label	Drive module data label. Refer to the <i>VLT® Parallel Drive Modules Installation Guide</i> for details.
3	Product label	Drive module product label. Refer to the <i>VLT® Parallel Drive Modules Installation Guide</i> for details.

Illustration 3.3 Drive Module Overview

Components and their functions

Illustration 3.4 provides a functional description of the drive module components. Each drive module contains the following:

- Input rectifier section.
- Intermediate DC bus section.
- Inverter section.

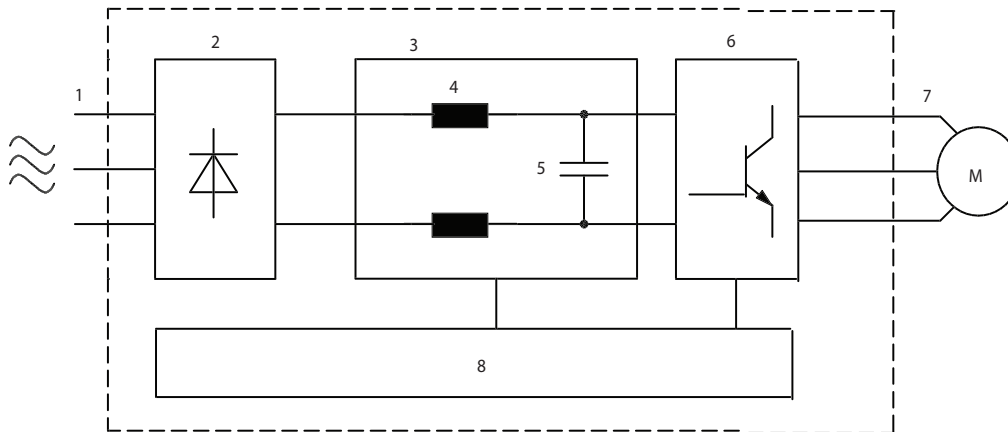

130BE894.11

Illustration 3.4 Drive Module Block Diagram

Area	Title	Functions
1	Mains input	3-phase AC mains power input to the drive module.
2	Input rectifier section	Converts mains input AC voltage into DC voltage.
3	Intermediate DC bus section	Act as a filter and stores energy in the form of DC voltage.
4	DC reactors	The DC reactors: <ul style="list-style-type: none"> • Filter the intermediate DC circuit voltage. • Reduce RMS current. • Raise the power factor reflected back to the line. • Reduce harmonics on the AC input.
5	Capacitor bank	Stores the DC power and provides ride-through protection for short power losses.
6	Inverter section	Converts the DC voltage into a variable, controlled PWM AC output voltage to the motor.
7	Motor output	Output to the motor being controlled.
8	Power card	<ul style="list-style-type: none"> • Monitors input and motor current to provide efficient operation and control. • Monitors the user interface and performs external commands. • Can provide status output and control. • In a drive system, a ribbon cable links the power card to the MDCIC on the control shelf. The MDCIC provides supervision over the drive modules in the system.

Table 3.1 Single Drive Module - Simplified Block Diagram

3.4 Control Shelf

The control shelf contains the LCP, MDCIC, and control card. The LCP provides access to the system parameters. The MDCIC is connected to each of the drive modules via a ribbon cable and communicates to the control card. The control card controls the operation of the drive modules.

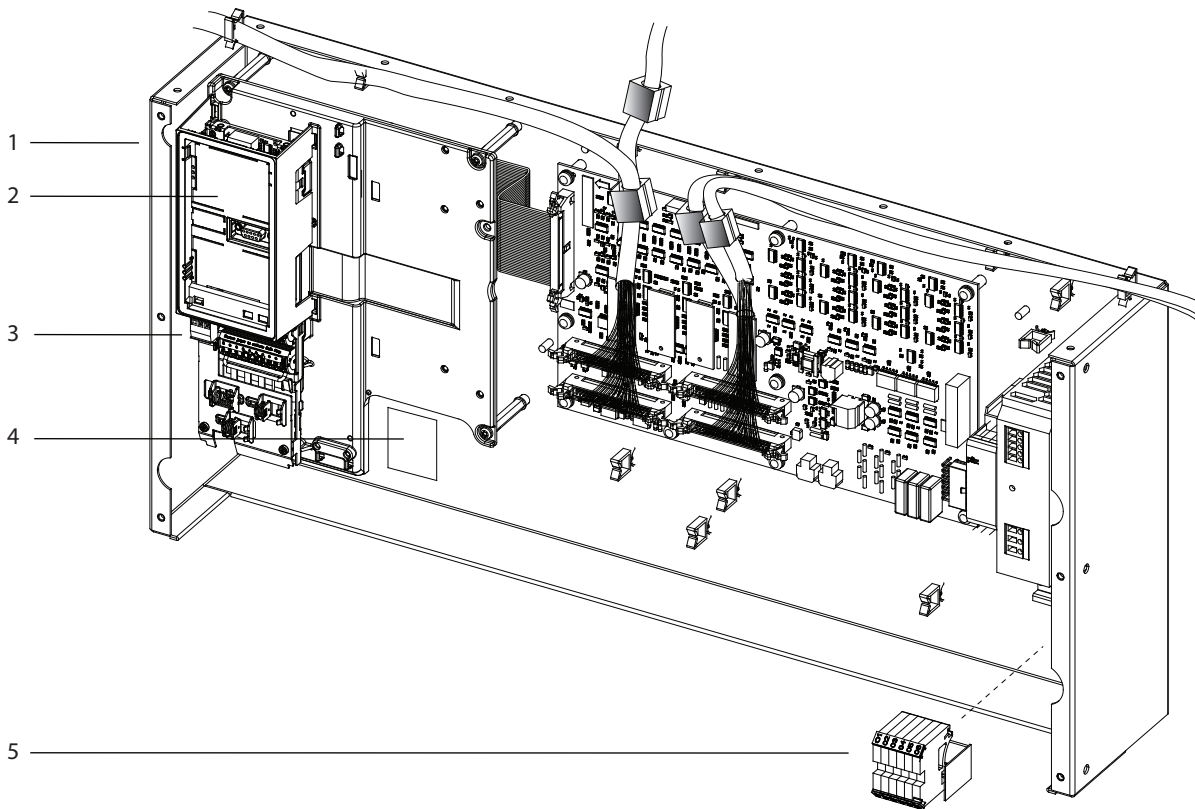

1	Control shelf	Interfaces with, and controls, the various drive system components. Allows the connection of an external control device.
2	LCP cradle	Cradle where the LCP may optionally be installed.
3	Control terminal blocks	Terminal blocks for connecting control wiring.
4	Top-level drive system label	Label describing the drive system at the top-level. For details, refer to the <i>VLT® Parallel Drive Modules Installation Guide</i> .
5	Relay terminal blocks	Terminal blocks for connecting the relay cable from the relay connector on the top plate of drive module 1.

Illustration 3.5 Control Shelf

4 Commissioning

4.1 Safety Instructions

See *chapter 2 Safety* for general safety instructions.

⚠ WARNING

HIGH VOLTAGE

The drive system contains high voltage when connected to AC mains input power, DC supply, or load sharing. Failure to perform installation, startup, and maintenance by qualified personnel can result in death or serious injury.

Before applying power:

1. Ensure that input power to the unit is OFF and locked out. Do not rely on the drive system's disconnect switches for input power isolation.
2. Verify that there is no voltage on mains terminals L1 (91), L2 (92), and L3 (93), phase-to-phase, and phase-to-ground.
3. Verify that there is no voltage on motor terminals 96 (U), 97 (V), and 98 (W), phase-to-phase, and phase-to-ground.
4. Confirm continuity of the motor by measuring resistance values on U–V (96–97), V–W (97–98), and W–U (98–96).
5. Check for proper grounding of the drive system and the motor.
6. Inspect the drive system for loose connections on the terminals.
7. Confirm that the supply voltage matches the voltage of the drive system and the motor.

4.2 Applying Power

⚠ WARNING

UNINTENDED START

When the drive system is connected to AC mains, the motor can start at any time. Unintended start during programming, service, or repair work can result in death, serious injury, or property damage. The motor can start via any of the following:

- An external switch.
- A fieldbus command.
- An input reference signal from the LCP.
- A cleared fault condition.
- Remote operation using MCT 10 Set-up Software.

To prevent unintended motor start:

- Disconnect the drive system from AC mains.
- Press [Off/Reset] on the LCP, before programming parameters.
- The drive system, motor, and any driven equipment must be fully wired and assembled when the drive is connected to AC mains.

Apply power to the drive system, according to the following steps:

1. Confirm that the input voltage is balanced within 3%. If not, correct the input voltage imbalance before proceeding. Repeat this procedure after the voltage correction.
2. Ensure that the wiring of any optional equipment matches the installation application.
3. Ensure that all operator devices are in the OFF position.
4. Close all panel doors and securely fasten all covers.
5. Apply power to the drive system. DO NOT start the drive system now. For units with a disconnect switch, turn the switch to the ON position to apply power to the drive system.

4.3 Local Control Panel (LCP)

4.3.1 Overview

The local control panel (LCP) is a combined display and keypad that allows the operator to monitor and control the system and motor. The LCP is shipped with the VLT® Parallel Drive Modules basic kit, mounted on the control shelf. During construction of the panel, the LCP is relocated from the control shelf to the cabinet door, for ease of access. See *Illustration 3.1*.

The LCP has several user functions:

- Starts, stops, and controls speed when in local control.
- Shows operational data, status, warnings, and alarms.
- Programs drive system functions.
- Manually resets the drive system after a fault when auto reset is inactive.

4.3.2 Layout

The LCP is activated when the drive system receives power from 1 of the following:

- Mains voltage.
- DC bus terminal.
- 24 V DC external supply.

The LCP is divided into the following 4 functional groups.

A. Display area

Each display readout has a parameter associated with it. Refer to *Illustration 4.1*. The default settings shown on the LCP are a function of the type of drive system being configured (VLT® HVAC Drive FC 102, VLT® AQUA Drive FC 202, or VLT® AutomationDrive FC 302). This information can be customized for the application by selecting options in the Quick Menus *Q1 My Personal Menu*.

Callout	Parameter number	Default settings		
		FC 102	FC 202	FC 302
A1.1	0-20	Reference %	Reference [unit]	Speed [RPM]
A1.2	0-21	Motor current	Analog input 53	Motor current
A1.3	0-22	Power [kW]	Motor current	Power [kW]
A2	0-23	Frequency	Frequency	Frequency
A3	0-24	kWh counter	Feedback [unit]	Reference %

Table 4.1 Legend to *Illustration 4.1*, LCP Display Area

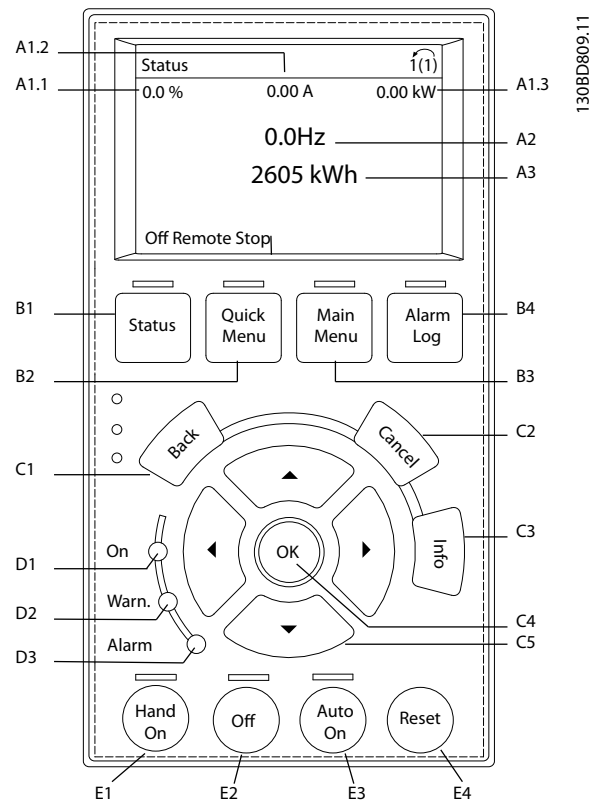

Illustration 4.1 Local Control Panel (LCP)

B. Menu keys

Menu keys are used to access the menu for setting up parameters, toggling through status display modes during normal operation, and viewing fault log data.

Callout	Key	Function
B1	Status	Shows operational information.
B2	Quick Menu	Allows access to parameters for initial set-up instructions and provides detailed application steps. See <i>chapter 4.4 Programming the Drive System</i> .
B3	Main Menu	Allows access to all parameters. See <i>chapter 8.3 Parameter Menu Structure</i> .
B4	Alarm Log	Shows a list of current warnings, the last 10 alarms, and the maintenance log.

Table 4.2 Legend to *Illustration 4.1*, LCP Menu Keys

C. Navigation keys

Navigation keys are used for programming functions and moving the display cursor. The navigation keys also provide speed control in local (hand) operation. The display brightness can be adjusted by pressing [Status] and [▲]/[▼] keys.

Callout	Key	Function
C1	Back	Reverts to the previous step or list in the menu structure.
C2	Cancel	Cancels the last change or command as long as the display mode has not changed.
C3	Info	Shows a definition of the function being shown.
C4	OK	Accesses parameter groups or enables an option.
C5	▲ ▼ ◀ ▶	Moves between items in the menu.

Table 4.3 Legend to *Illustration 4.1*, LCP Navigation Keys

D. Indicator lights

Indicator lights are used to identify the drive system status and to provide a visual notification of warning or fault conditions.

Callout	Indicator	Indicator light	Function
D1	On	Green	Activates when the drive system receives power from the mains voltage or a 24 V external supply.
D2	Warn.	Yellow	Activates when warning conditions are active. Text appears in the display area identifying the problem.
D3	Alarm	Red	Activates during a fault condition. Text appears in the display area identifying the problem.

Table 4.4 Legend to *Illustration 4.1*, LCP Indicator Lights

E. Operation keys and reset

The operation keys are found toward the bottom of the local control panel.

Callout	Key	Function
E1	Hand On	Starts the drive system in local control. An external stop signal by control input or serial communication overrides the local hand on.
E2	Off	Stops the motor but does not remove power to the drive system.
E3	Auto On	Puts the system in remote operational mode so it can respond to an external start command by control terminals or serial communication.
E4	Reset	Resets the drive system manually after a fault has been cleared.

Table 4.5 Legend to *Illustration 4.1*, LCP Operation Keys, and Reset

4.3.3 Menus

4.3.3.1 Quick Menu Mode

The LCP provides access to all parameters listed under the Quick Menu. To show the list of options in the Quick Menu, press [Quick Menu].

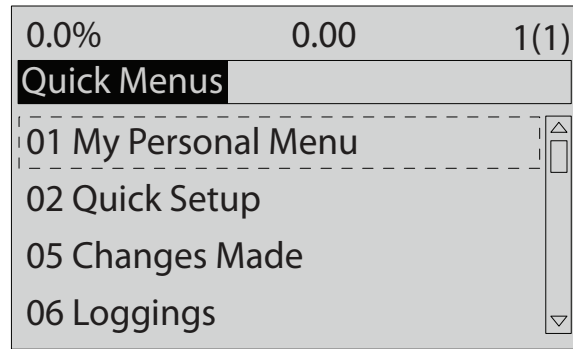

Illustration 4.2 Quick Menu View

4.3.3.2 Q1 My Personal Menu

The Personal Menu is used to define the LCP readout display (see *chapter 4.3.2 Layout*) and store pre-selected parameters. Use up to 20 pre-programmed parameters to store important setup values, thus simplifying on-site commissioning and fine-tuning for large-scale applications. These parameters are selected in *parameter 0-25 My Personal Menu*.

Parameter	Default setting
Parameter 0-01 Language	English
Parameter 0-20 Display Line 1.1 Small	Reference %
Parameter 0-21 Display Line 1.2 Small	Motor Current
Parameter 0-22 Display Line 1.3 Small	Power [kW]
Parameter 0-23 Display Line 2 Large	Frequency
Parameter 0-24 Display Line 3 Large	kWh Counter
Parameter 15-51 Frequency Converter Serial Number	-

Table 4.6 Q1 My Personal Menu Settings, FC 102

Parameter	Default setting
Parameter 0-01 Language	English
Parameter 0-20 Display Line 1.1 Small	Reference [Unit]
Parameter 0-21 Display Line 1.2 Small	Analog Input 53
Parameter 0-22 Display Line 1.3 Small	Motor Current
Parameter 0-23 Display Line 2 Large	Frequency
Parameter 0-24 Display Line 3 Large	Feedback [Unit]
Parameter 15-51 Frequency Converter Serial Number	-

Table 4.7 Q1 My Personal Menu Settings, FC 202

Parameter	Default setting
Parameter 0-01 Language	English
Parameter 0-20 Display Line 1.1 Small	Speed [RPM]
Parameter 0-21 Display Line 1.2 Small	Motor Current
Parameter 0-22 Display Line 1.3 Small	Power [kW]
Parameter 0-23 Display Line 2 Large	Frequency
Parameter 0-24 Display Line 3 Large	Reference %
Parameter 15-51 Frequency Converter Serial Number	-

Table 4.8 Q1 My Personal Menu Settings, FC 302

4.3.3.3 Q2 Quick Setup

The parameters in *Q2 Quick Setup* are the basic parameters that are always necessary for set-up. This menu provides the most efficient set-up for most applications. Perform the unit set-up in the order listed. See *chapter 4.4.1 Entering System Information* for the set-up steps.

4.3.3.4 Q5 Changes Made

Select *Q5 Changes Made* to get information about:

- The 10 most recent changes.
- Changes made from default setting.

4.3.3.5 Q6 Loggings

Use *Q6 Loggings* for fault finding.

To get information about the display line readout, select *Loggings*. The information is shown as graphs. Only display parameters selected in *parameter 0-20 Display Line 1.1 Small* and *parameter 0-24 Display Line 3 Large* can be viewed. It is possible to store up to 120 samples in the memory for later reference.

Q6 Loggings	
Parameter 0-20 Display Line 1.1 Small	Speed [RPM]
Parameter 0-21 Display Line 1.2 Small	Motor current
Parameter 0-22 Display Line 1.3 Small	Power [kW]
Parameter 0-23 Display Line 2 Large	Frequency
Parameter 0-24 Display Line 3 Large	Reference %

Table 4.9 Loggings Parameter Examples

4.3.3.6 Main Menu Mode

The LCP provides access to the *Main Menu* mode. Select the *Main Menu* mode by pressing the [Main Menu] key. The resulting readout appears on the LCP display.

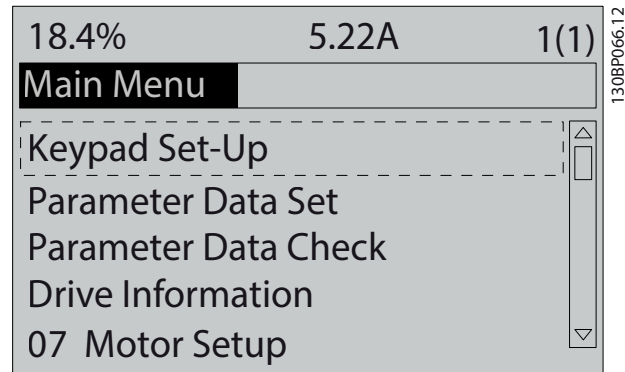

Illustration 4.3 Main Menu View

Lines 2 through 5 on the display show a list of parameter groups that can be selected via the ▲ and ▼ keys.

All parameters can be changed in the Main Menu. Option cards added to the unit enable extra parameters associated with the option device.

4.4 Programming the Drive System

For detailed information on the key functions on the local control panel (LCP), see *chapter 4.3 Local Control Panel (LCP)*. For information on parameter settings, see *chapter 4.7 Parameter Settings*.

Parameter overview

Parameter settings control the operation of the drive system, and are accessed via the LCP. These settings are assigned a default value at the factory, but customers can configure them for their unique application. Each parameter has a name and number that remain the same regardless of the programming mode.

In the Main Menu mode, the parameters are divided into groups. The first digit of the parameter number (from the left) indicates the parameter group number. The parameter group is then broken down into sub-groups, if necessary. For example:

0-** Operation/Display	Parameter group
0-0* Basic Settings	Parameter sub-group
Parameter 0-01 Language	Parameter
Parameter 0-02 Motor Speed Unit	Parameter
Parameter 0-03 Regional Settings	Parameter

Table 4.10 Example of Parameter Group Hierarchy

Moving around the parameters

Navigate through the parameters using the following LCP keys:

- Press [▲] [▼] to scroll up or down.
- Press [◀] [▶] to shift a space to the left or right of a decimal point while editing a decimal parameter value.
- Press [OK] to accept the change or [Cancel] to disregard the change and exit edit mode.
- Press [Back] twice to show the status screen, or press [Main Menu] once to go back to the main menu.

Danfoss has a software program available for developing, storing, and transferring drive system programming. The MCT 10 Set-up Software allows the installer or operator to connect a PC to the drive system and perform live programming, rather than using the LCP. Also, this software can be used to do all the programming offline and then simply download it to the drive system. As a further option, the entire drive system profile can be loaded onto the PC for back-up storage or analysis.

The USB connector or RS485 terminal of the drive system can be used to connect the PC for programming and downloads.

For information, and to download the basic version of MCT 10 Set-up Software, see www.danfoss.com/BusinessAreas/DrivesSolutions/Software+MCT10/MCT10+Downloads.htm. The advanced version can be obtained on a CD by requesting part number 130B1000. For detailed information on how to program using the MCT 10 Set-up Software, refer to the *VLT® Motion Control Tools MCT 10 Set-up Software Operating Instructions*.

4.4.1 Entering System Information

NOTICE

SOFTWARE DOWNLOAD

For commissioning using a PC, install MCT 10 Set-up Software. The software is available for download (basic version) or for ordering (advanced version, code number 130B1000). For more information and downloads, see www.danfoss.com/BusinessAreas/DrivesSolutions/Software+MCT10/MCT10+Downloads.htm.

To enter basic system information into the drive system, use the following steps. Recommended parameter settings are intended for startup and check-out purposes. Application settings vary.

1. Press [Main Menu] on the LCP.
2. Select 0-** Operation/Display and press [OK].
3. Select 0-0* Basic Settings and press [OK].
4. Select parameter 0-03 Regional Settings and press [OK].
5. Select [0] International or [1] North America as appropriate and press [OK]. (This action changes the default settings for several basic parameters).
6. Press [Quick Menu] on the LCP.
7. Change the following parameter settings if necessary. The motor data is found on the motor nameplate.

NOTICE

These steps assume that an asynchronous motor is used, but the VLT® Parallel Drive Modules drive system does support permanent magnet motors. For more information on permanent magnet motors, see the *VLT® AutomationDrive FC 301/FC 302 Programming Guide*.

Parameter	Default setting
Parameter 0-01 Language	English
Parameter 0-20 Display Line 1.1 Small	Power size dependent
Parameter 0-22 Display Line 1.3 Small	Power size dependent
Parameter 0-23 Display Line 2 Large	Power size dependent
Parameter 0-24 Display Line 3 Large	Power size dependent
Parameter 1-25 Motor Nominal Speed	Power size dependent
Parameter 5-12 Terminal 27 Digital Input	Coast inverse
Parameter 3-02 Minimum Reference	0.000 RPM
Parameter 3-03 Maximum Reference	1500.000 RPM
Parameter 3-41 Ramp 1 Ramp Up Time	Power size dependent
Parameter 3-42 Ramp 1 Ramp Down Time	Power size dependent
Parameter 3-13 Reference Site	Linked to Hand On/Auto On
Parameter 1-29 Automatic Motor Adaptation (AMA)	Off

Table 4.11 Quick Setup Settings

NOTICE

MISSING INPUT SIGNAL

When the LCP shows AUTO REMOTE COASTING or alarm 60, External Interlock, the unit is ready to operate but is missing an input signal. See chapter 6.5.2 WARNING 60, External interlock for details.

4.4.2 Q3 Function Set-ups

The *Function Set-up* provides quick and easy access to all parameters required for most applications. Among other features, it also includes parameters for selecting which variables to display on the LCP, digital preset speeds, scaling of analog references, closed loop single-zone and multi-zone applications, and functions specifically related to the applications. For more on *Function Set-up*, including programming examples, refer to the operating instructions and programming guides applicable to the VLT® HVAC Drive FC 102, VLT® AQUA Drive FC 202, or VLT® AutomationDrive FC 301/FC 302 series of VLT® Parallel Drive Modules used in the drive system.

4.4.3 Control Terminal Programming

The control terminals can be programmed using the LCP.

- Each terminal has specified functions it can perform.
- Parameters associated with the terminal enable the function.
- For proper drive system functioning, the control terminals must be:
 - Wired properly.
 - Programmed for the intended function.
 - Receiving a signal.

See *Table 8.2* for control terminal parameter number and default setting. (Default setting can change based on the selection in *parameter 0-03 Regional Settings*).

The following example shows how terminal 18 is accessed to see the default setting:

1. Press [Main Menu] twice, scroll to *parameter group 5-** Digital In/Out Parameter Data Set* and then press [OK].

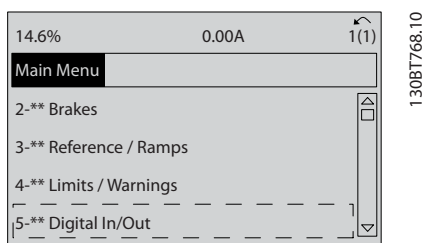

Illustration 4.4 Main Menu Display Example

2. Scroll to *parameter group 5-1* Digital Inputs* and then press [OK].

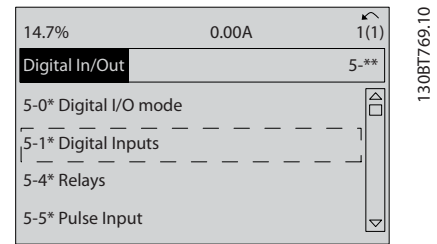

Illustration 4.5 Parameter Group Display Example

3. Scroll to *parameter 5-10 Terminal 18 Digital Input*. Press [OK] to access function options. The default setting *Start* is displayed. If this terminal must be reprogrammed, the LCP can be used to access the options available for this parameter and then select a different value.

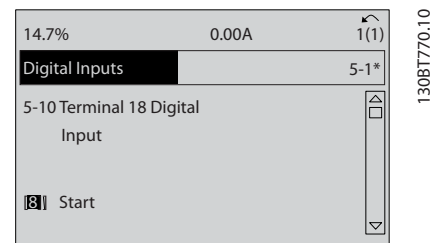

Illustration 4.6 Function Choice Display Example

4.4.4 Configuring Automatic Energy Optimization

Automatic energy optimization (AEO) is a procedure that minimizes voltage to the motor, reducing energy consumption, heat, and noise.

1. Press [Main Menu].
2. Select *1-** Load and Motor* and press [OK].
3. Select *1-0* General Settings* and press [OK].
4. Select *parameter 1-03 Torque Characteristics* and press [OK].
5. Select either [2] *Auto Energy Optim CT* or [3] *Auto Energy Optim VT* and press [OK].

4.4.5 Configuring Automatic Motor Adaptation

Automatic motor adaptation (AMA) is a procedure that optimizes compatibility between the drive system and the motor.

During this procedure, the drive system builds a mathematical model of the motor for regulating output motor current. The procedure also tests the input phase

balance of electrical power. It compares the motor characteristics with the data entered in *parameters 1-20 to 1-25*.

NOTICE

If warnings or alarms occur, see *chapter 6.5 List of Warnings and Alarms*

Some motors are unable to run the complete version of the test. In that case, or if an output filter is connected to the motor, select [2] *Enable reduced AMA*.

For best results, run this procedure on a cold motor.

1. Press [Main Menu].
2. Select *1-** Load and Motor* and then press [OK].
3. Select *1-2* Motor Data* and then press [OK].
4. Select *parameter 1-29 Automatic Motor Adaptation (AMA)* and then press [OK].
5. Select [1] *Enable complete AMA* and then press [OK].
6. Press [Hand On] and then [OK].
The test runs automatically and indicates when it is complete.

4.5 Testing Before System Startup

⚠ WARNING

MOTOR START

Failure to ensure that the motor, system, and any attached equipment are ready for start can result in personal injury or equipment damage. Before start:

- Ensure that equipment is safe to operate under any condition.
- Ensure that the motor, system, and any attached equipment are ready for start.

4.5.1 Motor Rotation

NOTICE

If the motor runs in the wrong direction, it can damage equipment. Before running the motor, check its direction of rotation by briefly running the motor. Run the motor at either 5 Hz or the minimum frequency set in *parameter 4-12 Motor Speed Low Limit [Hz]* as follows:

1. Press [Hand On].
2. Move the cursor to the left of the decimal point by using the left arrow key and then enter an RPM value that causes the motor to rotate slowly.
3. Press [OK].
4. If the motor rotation is wrong, change *parameter 1-06 Clockwise Direction* to [1] *Inverse*.

4.5.2 Encoder Rotation

Only check encoder rotation if encoder feedback is used. For more information on the encoder option, refer to the option manual.

1. Select [0] *Open loop* in *parameter 1-00 Configuration Mode*.
2. Select [1] *24 V encoder* in *parameter 7-00 Speed PID Feedback Source*.
3. Press [Hand On].
4. Press [▶] for positive speed reference (*parameter 1-06 Clockwise Direction* at [0] *Normal*).
5. Check in *parameter 16-57 Feedback [RPM]* that the feedback is positive.

NOTICE

NEGATIVE FEEDBACK

If the feedback is negative, the encoder connection is wrong. Use either *parameter 5-71 Term 32/33 Encoder Direction* or *parameter 17-60* to inverse the direction, or reverse the encoder cables. *Parameter 17-60 Feedback Direction* is only available with the VLT® Encoder Input MCB 102 option.

4.5.3 Local Control Test

Perform the local control test as follows:

1. Press [Hand On] to provide a local start command to the drive system.
2. Accelerate the unit by pressing [▲] until full speed is reached. Moving the cursor to the left of the decimal point provides quicker input changes.
3. Note any acceleration problems.
4. Press [Off]. Note any deceleration problems.

If acceleration or deceleration problems occur, see *chapter 6.6 Troubleshooting*. To reset the drive system after a trip, clear all faults and then manually reset the system. For a list of warnings and alarms, see *chapter 6.5 List of Warnings and Alarms*.

4.6 System Startup

⚠ WARNING

MOTOR START

Failure to ensure that the motor, system, and any attached equipment are ready for start can result in personal injury or equipment damage. Before start:

- Ensure that equipment is safe to operate under any condition.
- Ensure that the motor, system, and any attached equipment are ready for start.

The procedure in this section requires the completion of user wiring and application programming. The following procedure is recommended after application set-up is completed.

1. Press [Auto On].
2. Apply an external run command.
External run commands can be sent from various sources, for example a switch, a key, or a programmable logic controller (PLC).
3. Adjust the speed reference throughout the speed range.
4. Ensure that the system works as intended by checking the sound and vibration level of the motor.
5. Remove the external run command.

If warnings or alarms occur, see *chapter 6.5 List of Warnings and Alarms*.

4.7 Parameter Settings

Establishing the correct programming for applications often requires setting the functions of several parameters. Details for parameters are provided in *chapter 8.3 Parameter Menu Structure*.

Parameter settings are stored internally in the drive system, providing the following advantages:

- Parameter settings can be uploaded into the LCP memory and stored as a back-up.
- Multiple units can be programmed quickly by connecting the LCP to each unit, in turn, and downloading the stored parameter settings.
- Custom settings that are stored in the LCP are not changed when restoring the factory default settings.

4.7.1 Uploading and Downloading Parameter Settings

The drive system operates by referencing parameters stored on the control card, located within the drive system. The upload and download functions move the parameter settings between the control card and the LCP.

1. Press [Off].
2. Go to *parameter 0-50 LCP Copy* and then press [OK].
3. Select 1 of the following:
 - To upload data from the control card to the LCP, select [1] *All to LCP*.
 - To download data from the LCP to the control card, select [2] *All from LCP*.
4. Press [OK]. A progress bar shows the uploading or downloading process.
5. Press [Hand On] or [Auto On].

4.7.2 Restoring Factory Default Settings

NOTICE

LOSS OF DATA

Loss of programming, motor data, localization, and monitoring records occurs when restoring default settings. Before restoring default settings, create a back-up by uploading this data to the LCP. See *chapter 4.7.1 Uploading and Downloading Parameter Settings*.

Restore the default parameter settings by initializing the unit. Initialization is carried out either automatically or manually, as described in the following procedures.

Automated initialization (recommended)

Automated initialization is performed through *parameter 14-22 Operation Mode*. This process does not reset settings such as the following:

- Running hours.
- Serial communication options.
- Personal menu settings.
- Fault log, alarm log, and other monitoring functions.

Perform automated initialization as follows:

1. Press [Main Menu] twice to access the parameters.
2. Go to *parameter 14-22 Operation Mode* and then press [OK].
3. Scroll to *Initialization* and then press [OK].
4. Remove power from the drive system and wait for the display to turn off.
5. Apply power to the drive system.
Default parameter settings are restored during startup. As a result, startup takes slightly longer than normal.
6. Alarm 80 is shown.
7. Press [Reset].

Manual initialization

Manual initialization erases all motor, programming, localization, and monitoring data before restoring factory default settings. It does not, however, reset the following information:

- *Parameter 15-00 Operating hours*
- *Parameter 15-03 Power Up's*
- *Parameter 15-04 Over Temp's*
- *Parameter 15-05 Over Volt's*

Perform manual initialization as follows:

1. Remove power from the drive system and wait for the display to turn off.
2. Press and hold [Status], [Main Menu], and [OK] simultaneously while applying power to the unit. Hold approximately 5 s or until an audible click is heard and the drive system's cooling fan starts.

Factory default parameter settings are restored during startup. As a result, startup takes slightly longer than normal.

5 Application Set-up Examples

5.1 Introduction

The examples in this section are intended as a quick reference for common applications.

- Parameter settings use the regional default values unless otherwise indicated (selected in *parameter 0-03 Regional Settings*).
- Parameters associated with the terminals and their settings are listed to the right of the diagrams.
- Where switch settings for analog terminals A53 or A54 are required, those settings are also shown.

NOTICE

STO SAFETY

When using the Safe Torque Off (STO) feature, follow all safety measures related to terminal 37, as described in the *VLT® Frequency Converters Safe Torque Off Operating Instructions*.

5.2 Application Examples

This section lists the various application examples, and gives the parameter settings and special notes, as needed, for each example.

NOTICE

PELV COMPLIANCE

When motor temperature is monitored via a thermistor or KTY sensor, PELV compliance is not achieved if short circuits occur between the motor windings and the sensor. Use reinforced or double insulation to ensure PELV compliance.

5.2.1 Automatic Motor Adaptation (AMA)

		Parameters	
FC		Function	Setting
+24 V	12	Parameter 1-29 Automatic Motor Adaptation (AMA)	[1] Enable complete AMA
+24 V	13		
D IN	18	Parameter 5-12 Terminal 27 Digital Input	[2]* Coast inverse
D IN	19		
COM	20	*=Default value	
D IN	27	Notes/comments: Parameter group 1-2* Motor Data must be set according to the motor data plate.	
D IN	29		
D IN	32		
D IN	33		
D IN	37		
+10 V	50		
A IN	53		
A IN	54		
COM	55		
A OUT	42		
COM	39		

Table 5.1 AMA with T27 Connected

		Parameters	
FC		Function	Setting
+24 V	12	Parameter 1-29 Automatic Motor Adaptation (AMA)	[1] Enable complete AMA
+24 V	13		
D IN	18	Parameter 5-12 Terminal 27 Digital Input	[0] No operation
D IN	19		
COM	20	*=Default value	
D IN	27	Notes/comments: Set parameter group 1-2* Motor Data according to motor nameplate.	
D IN	29		
D IN	32		
D IN	33		
D IN	37		
+10 V	50		
A IN	53		
A IN	54		
COM	55		
A OUT	42		
COM	39		

Table 5.2 AMA without T27 Connected

5.2.2 RS485 Network Connection

		Parameters	
FC		Function	Setting
+24 V	12	Parameter 8-30 P rotocol	[0] FC*
+24 V	13		
D IN	18		
D IN	19		
COM	20	Parameter 8-31 A ddress	1*
D IN	27		
D IN	29	Parameter 8-32 B aud Rate	9600*
D IN	32		
D IN	33	*=Default value	
D IN	37	Notes/comments: Select protocol, address, and baud rate in the above-mentioned parameters. Terminals 68 and 69 are connected to an RS485 serial communication circuit from an external controller.	
+10 V	50		
A IN	53		
A IN	54		
COM	55		
A OUT	42		
COM	39		
RI	01-03		
R2	04-06		
	61		
	68		
	69		

Table 5.3 RS485 Network Connection

5.2.3 Smart Logic Controller (SLC) Mode

		Parameters	
FC		Function	Setting
+24 V	12	Parameter 4-30 Motor Feedback Loss Function	[1] Warning
+24 V	13		
D IN	18		
D IN	19		
COM	20	Parameter 4-31 Motor Feedback Speed Error	100 RPM
D IN	27		
D IN	29	Parameter 4-32 Motor Feedback Loss Timeout	5 s
D IN	32		
D IN	33	Parameter 7-00 S peed PID Feedback Source	[2] MCB 102
D IN	37		
+10 V	50	Parameter 17-11 Resolution (PPR)	1024*
A IN	53		
A IN	54	Parameter 13-00 SL Controller Mode	[1] On
COM	55		
A OUT	42	Parameter 13-01 Start Event	[19] Warning
COM	39		
RI	01-03	Parameter 13-02 Stop Event	[44] Reset key
R2	04-06		
	61	Parameter 13-10 Comparator Operand	[21] Warning no.
	68		
	69	Parameter 13-11 Comparator Operator	[1] ≈*
		Parameter 13-12 Comparator Value	90
		Parameter 13-51 SL Controller Event	[22] Comparator 0
		Parameter 13-52 SL Controller Action	[32] Set digital out A low
		Parameter 5-40 F unction Relay	[80] SL digital output A
		*=Default value	
Notes/comments: If the limit in the feedback monitor is exceeded, warning 90, Feedback monitor is issued. The SLC monitors the warning and in the case that it becomes true, relay 1 is triggered. External equipment may indicate that service is required. If the feedback error goes below the limit again within 5 s, the drive system continues and the warning disappears. However, relay 1 is still triggered until [Reset] is pressed on the LCP.			

Table 5.4 Using SLC to Set a Relay

5.2.4 Mechanical Brake Control

		Parameters	
		Function	Setting
		Parameter 1-00 Configuration Mode [0] Speed open loop	
		Parameter 1-01 Motor Control Principle [1] VVC+	
		Parameter 5-40 Function Relay [32] Mech. brake ctrl.	
		Parameter 5-10 Terminal 18 Digital Input [8] Start*	
		Parameter 5-11 Terminal 19 Digital Input [11] Start reversing	
		Parameter 1-71 Start Delay 0.2	
		Parameter 1-72 Start Function [5]VVC+/FLUX Clockwise	
		Parameter 1-76 Start Current $I_{m,n}$	
		Parameter 2-20 Release Brake Current App. dependent	
		Parameter 2-21 Activate Brake Speed [RPM] Half of nominal slip of the motor	
		* = Default value	

Table 5.5 Mechanical Brake Control (Open Loop)

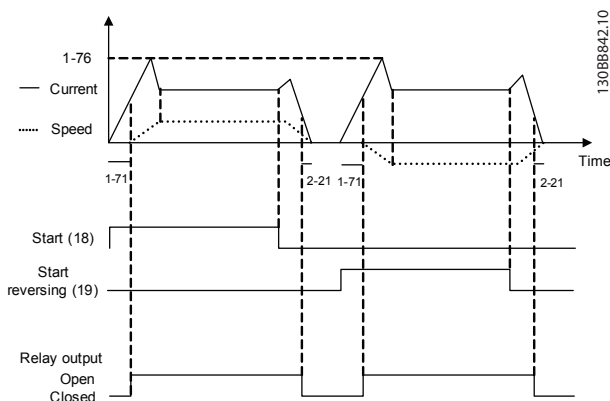

Illustration 5.1 Mechanical Brake Control (Open Loop)

5.2.5 Open Loop Speed Control

		Parameters	
		Function	Setting
		Parameter 6-10 Terminal 53 Low Voltage 0.07 V*	
		Parameter 6-11 Terminal 53 High Voltage 10 V*	
		Parameter 6-14 Terminal 53 Low Ref./Feedb. Value 0 Hz	
		Parameter 6-15 Terminal 53 High Ref./Feedb. Value 50 Hz	
		* = Default value	
		Notes/comments: Assumptions are 0 V DC input = 0 Hz speed and 10 V DC input = 50 Hz speed. Terminals 53 and 55 are connected to a 0-10 V DC voltage input from an external controller.	

Table 5.6 Analog Speed Reference (Voltage)

		Parameters	
		Function	Setting
	Parameter 6-12 Terminal 53 Low Current	4 mA*	
	Parameter 6-13 Terminal 53 High Current	20 mA*	
	Parameter 6-14 Terminal 53 Low Ref./Feedb. Value	0 Hz	
	Parameter 6-15 Terminal 53 High Ref./Feedb. Value	50 Hz	
	* = Default value		
Notes/comments:			
Assumptions are 4 mA input = 0 Hz speed and 20 mA input = 50 Hz speed.			
Terminals 53 and 55 are connected to a 4–20 mA current input from an external controller.			

Table 5.7 Analog Speed Reference (Current)

		Parameters	
		Function	Setting
	Parameter 6-10 Terminal 53 Low Voltage	0.07 V*	
	Parameter 6-11 Terminal 53 High Voltage	10 V*	
	Parameter 6-14 Terminal 53 Low Ref./Feedb. Value	0 RPM	
	Parameter 6-15 Terminal 53 High Ref./Feedb. Value	1500 RPM	
	* = Default value		
Notes/comments:			

Table 5.8 Speed Reference (using a Manual Potentiometer)

		Parameters	
		Function	Setting
	Parameter 5-10 Terminal 18 Digital Input	[8] Start*	
	Parameter 5-12 Terminal 27 Digital Input	[19] Freeze Reference	
	Parameter 5-13 Terminal 29 Digital Input	[21] Speed Up	
	Parameter 5-14 Terminal 32 Digital Input	[22] Speed Down	
	* = Default value		
	Notes/comments:		

Table 5.9 Speed Up/Speed Down

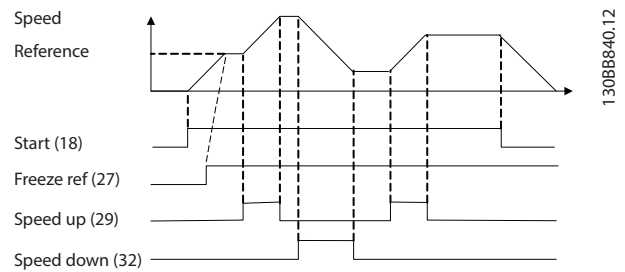

Illustration 5.2 Speed Up/Speed Down

5.2.6 Start/Stop

		Parameters	
FC		Function	Setting
+24 V	120	Parameter 5-10 Terminal 18 Digital Input	[8] Start*
+24 V	130		
D IN	180	Parameter 5-12 Terminal 27 Digital Input	[0] No operation
D IN	190		
COM	200	Parameter 5-19 Terminal 37 Safe Stop	[1] Safe Alarm
D IN	270		
D IN	290	* = Default value	
D IN	320	Notes/comments:	
D IN	330	If parameter 5-12 Terminal 27 Digital Input is set to [0] No operation, a jumper wire to terminal 27 is not needed.	
D IN	370		
+10	500		
A IN	530		
A IN	540		
COM	550		
A OUT	420		
COM	390		

Table 5.10 Start/Stop Command with Safe Torque Off (STO) Option

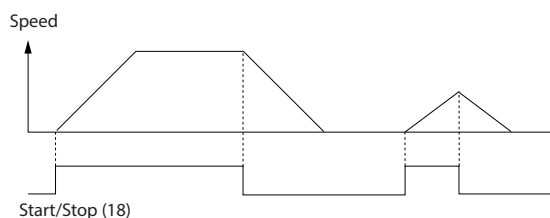

Illustration 5.3 Start/Stop Command with Safe Torque Off (STO)

		Parameters	
FC		Function	Setting
+24 V	120	Parameter 5-10 Terminal 18 Digital Input	[9] Latched Start
+24 V	130		
D IN	180	Parameter 5-12 Terminal 27 Digital Input	[6] Stop Inverse
D IN	190		
COM	200	* = Default value	
D IN	270	Notes/comments:	
D IN	290	If parameter 5-12 Terminal 27 Digital Input is set to [0] No operation, a jumper wire to terminal 27 is not needed.	
D IN	320		
D IN	330		
D IN	370		
+10 V	500		
A IN	530		
A IN	540		
COM	550		
A OUT	420		
COM	390		

Table 5.11 Pulse Start/Stop

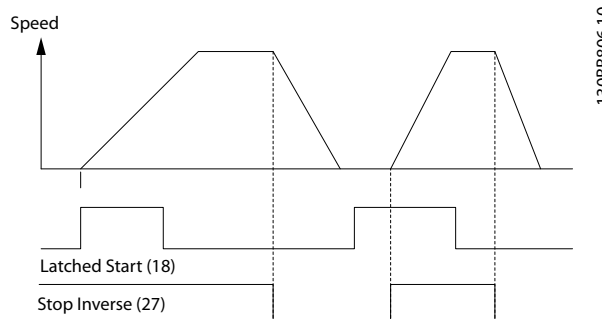

Illustration 5.4 Latched Start/Stop Inverse

5

		Parameters	
FC		Function	Setting
+24 V	12	Parameter 5-10 Terminal 18 Digital Input	[8] Start
+24 V	13	Parameter 5-11 Terminal 19 Digital Input	[10] Reversing*
D IN	18	Parameter 5-12 Terminal 27 Digital Input	[0] No operation
D IN	19	Parameter 5-14 Terminal 32 Digital Input	[16] Preset ref bit 0
COM	20	Parameter 5-15 Terminal 33 Digital Input	[17] Preset ref bit 1
D IN	27	Parameter 3-10 Preset Reference	
D IN	29	Preset ref. 0	25%
D IN	32	Preset ref. 1	50%
D IN	33	Preset ref. 2	75%
D IN	33	Preset ref. 3	100%
		* = Default value	
		Notes/comments:	

Table 5.12 Start/Stop with Reversing and 4 Preset Speeds

5.2.7 External Alarm Reset

		Parameters	
FC		Function	Setting
+24 V	12	Parameter 5-11 Terminal 19 Digital Input	[1] Reset
+24 V	13		
D IN	18		
D IN	19		
COM	20		
D IN	27		
D IN	29		
D IN	32		
D IN	33		
D IN	37		
		* = Default value	
		Notes/comments:	

Table 5.13 External Alarm Reset

5.2.8 Motor Thermistor

WARNING

THERMISTOR INSULATION

Risk of personal injury or equipment damage.

- To meet PELV insulation requirements, use only thermistors with reinforced or double insulation.

		Parameters	
VLT		Function	Setting
+24 V	12	Parameter 1-90 Motor Thermal Protection	[2] Thermistor trip
+24 V	13	Parameter 1-93 Thermistor Resource	[1] Analog input 53
D IN	18		
D IN	19		
COM	20		
D IN	27		
D IN	29		
D IN	32		
D IN	33		
D IN	37		
		* = Default value	
		Notes/comments:	
		If only a warning is needed, set parameter 1-90 Motor Thermal Protection to [1] Thermistor warning.	

Table 5.14 Motor Thermistor

5.3 Connection Examples for Control of Motor with External Signal Provider

NOTICE

The following examples refer only to the drive system's control card, *not* the filter.

5.3.1 Start/Stop

Terminal 18 = Parameter 5-10 Terminal 18 Digital Input [8] Start.

Terminal 27 = Parameter 5-12 Terminal 27 Digital Input [0] No operation (Default coast inverse)

Terminal 37 = Safe Torque Off.

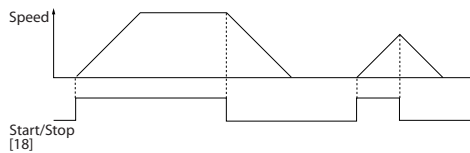
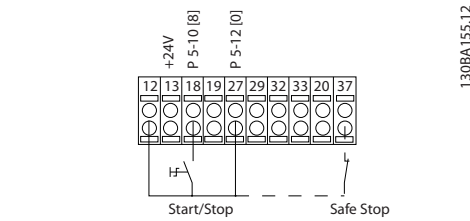

Illustration 5.5 Start/Stop Parameters

5.3.2 Pulse Start/Stop

Terminal 18 = Parameter 5-10 Terminal 18 Digital Input [9] Latched start.

Terminal 27 = Parameter 5-12 Terminal 27 Digital Input [6] Stop inverse.

Terminal 37 = Safe Torque Off.

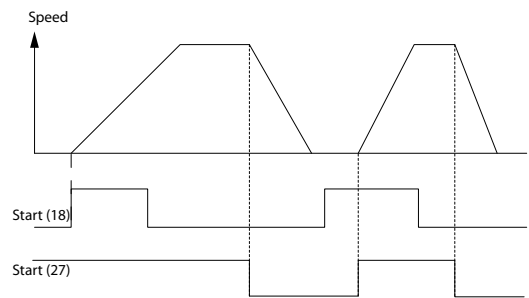
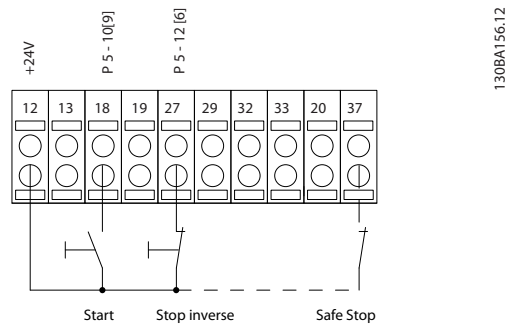

Illustration 5.6 Pulse Start/Stop Parameters

5.3.3 Speed Up/Down

Terminals 29/32 = Speed up/down

Terminal 18 = Parameter 5-10 Terminal 18 Digital Input [9] Start (default).

Terminal 27 = Parameter 5-12 Terminal 27 Digital Input [19] Freeze reference .

Terminal 29 = Parameter 5-13 Terminal 29 Digital Input [21] Speed up.

Terminal 32 = Parameter 5-14 Terminal 32 Digital Input [22] Speed down.

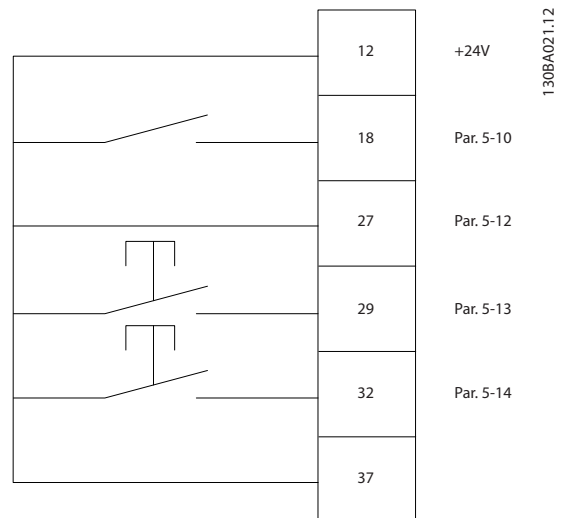

Illustration 5.7 Speed Control Parameters

5.3.4 Potentiometer Reference

Voltage reference via a potentiometer

Reference source 1 = [1] Analog input 53 (default).

Terminal 53, Low voltage = 0 V.

Terminal 53, High voltage = 10 V.

Terminal 53, Low ref./feedback = 0 RPM.

Terminal 53, High ref./feedback = 1500 RPM.

Switch S201 = OFF (U).

5

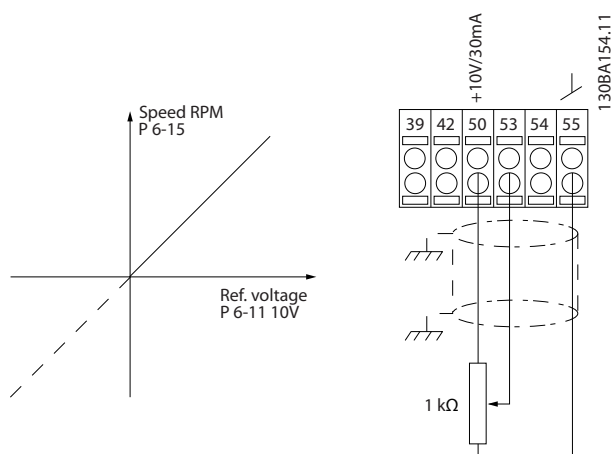

Illustration 5.8 Potentiometer Voltage Reference

6 Maintenance, Diagnostics, and Troubleshooting

6.1 Maintenance and Service

Under normal operating conditions and load profiles, the drive system is maintenance-free throughout its designed lifetime. To prevent breakdown, danger, and damage, examine the drive system at regular intervals depending on the operating conditions. Replace worn or damaged parts with original spare parts or standard parts. For service and support, refer to vlt-drives.danfoss.com/support/service/.

Inspect the following items if the drive system is installed in an aggressive environment.

- Built-in filter mats, cooling fans, and the heat sink require periodic cleaning. Determine the frequency of service based on the system's exposure to dust and contaminants.

6.2 Periodic Maintenance

Dust

When dust accumulates on electronic components, it acts as a layer of insulation. This layer reduces the cooling capacity of the components, and the components become warmer. The resulting hotter environment decreases the life of the electronic components. Keep the heat sink and fans in the drive modules free from dust build-up.

6.3 Status Messages

When the drive system is in status mode, status messages are generated automatically and appear in the bottom line of the LCP display (see *Illustration 6.1*.) Status messages are defined in *Table 6.1* to *Table 6.3*.

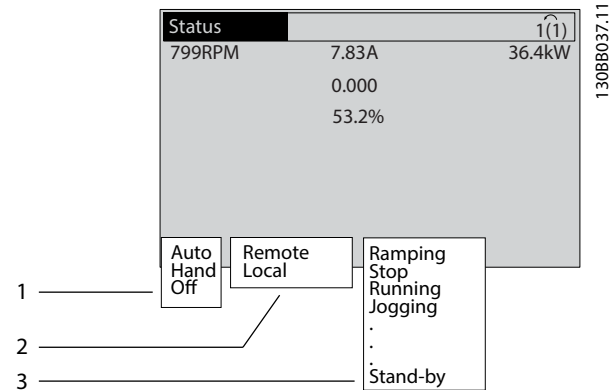

1	The 1 st part of the status line indicates where the stop/start command originates. See <i>Table 6.1</i> .
2	The 2 nd part of the status line indicates where the speed control originates. See <i>Table 6.2</i> .
3	The last part of the status line gives the present status of the drive system. The status shows the operational mode of the drive system. See <i>Table 6.3</i> .

Illustration 6.1 Status Display

NOTICE

In auto/remote mode, the drive system requires external commands to execute functions.

Table 6.1 to *Table 6.3* define the meaning of the displayed status messages.

Off	The drive system does not react to any control signal until [Auto On] or [Hand On] is pressed.
Auto	The start/stop commands are sent via the control terminals and/or the serial communication.
Hand	The navigation keys on the LCP can be used to control the drive system. Stop commands, reset, reversing, DC brake, and other signals applied to the control terminals can override local control.

Table 6.1 Operating Mode

Remote	The speed reference is given from: <ul style="list-style-type: none"> • External signals. • Serial communication. • Internal preset references.
Local	The drive system uses reference values from the LCP.

Table 6.2 Reference Site

AC brake	[2] AC brake was selected in <i>parameter 2-10 Brake Function</i> . The AC brake overmagnetizes the motor to achieve a controlled slow down.
AMA finish OK	Automatic motor adaptation (AMA) was carried out successfully.
AMA ready	AMA is ready to start. Press [Hand On] to start.
AMA running	AMA process is in progress.
Braking	The brake chopper is in operation. The brake resistor absorbs the generative energy.
Braking maximum	The brake chopper is in operation. The power limit for the brake resistor defined in <i>parameter 2-12 Brake Power Limit (kW)</i> has been reached.
Coast	<ul style="list-style-type: none"> • Coast inverse was selected as a function for a digital input (<i>parameter group 5-1* Digital Inputs</i>). The corresponding terminal is not connected. • Coast activated by serial communication.
Ctrl. ramp-down	[1] Control ramp-down was selected in <i>parameter 14-10 Mains Failure</i> . <ul style="list-style-type: none"> • The mains voltage is below the value set in <i>parameter 14-11 Mains Fault Voltage Level</i> at mains fault. • The drive system ramps down the motor using a controlled ramp down.
Current high	The drive system's output current is above the limit set in <i>parameter 4-51 Warning Current High</i> .
Current low	The drive system's output current is below the limit set in <i>parameter 4-52 Warning Speed Low</i> .
DC hold	DC hold is selected in <i>parameter 1-80 Function at Stop</i> and a stop command is active. The motor is held by a DC current set in <i>parameter 2-00 DC Hold Current</i> .

DC stop	The motor is held with a DC current (<i>parameter 2-01 DC Brake Current</i>) for a specified time (<i>parameter 2-02 DC Braking Time</i>). <ul style="list-style-type: none"> • DC brake is activated in <i>parameter 2-03 DC Brake Cut In Speed [RPM]</i> and a stop command is active. • DC brake (inverse) is selected as a function for a digital input (<i>parameter group 5-1* Digital Inputs</i>). The corresponding terminal is not active. • The DC brake is activated via serial communication.
Feedback high	The sum of all active feedbacks is above the feedback limit set in <i>parameter 4-57 Warning Feedback High</i> .
Feedback low	The sum of all active feedbacks is below the feedback limit set in <i>parameter 4-56 Warning Feedback Low</i> .
Freeze output	The remote reference is active, which holds the present speed. <ul style="list-style-type: none"> • Freeze output was selected as a function for a digital input (<i>parameter group 5-1* Digital Inputs</i>). The corresponding terminal is active. Speed control is only possible via the speed-up and speed-down terminal functions. • Hold ramp is activated via serial communication.
Freeze output request	A freeze output command has been given, but the motor remains stopped until a run permissive signal is received.
Freeze ref.	Freeze reference was selected as a function for a digital input (<i>parameter group 5-1* Digital Inputs</i>). The corresponding terminal is active. The drive system saves the actual reference. Changing the reference is now only possible via the speed-up and speed-down terminal functions.
Jog request	A jog command has been given, but the motor is stopped until a run permissive signal is received via a digital input.
Jogging	The motor runs as programmed in <i>parameter 3-19 Jog Speed [RPM]</i> . <ul style="list-style-type: none"> • Jog was selected as function for a digital input (<i>parameter group 5-1* Digital Inputs</i>). The corresponding terminal (for example, terminal 29) is active. • The jog function is activated via the serial communication. • The jog function was selected as a reaction for a monitoring function (for example, No signal). The monitoring function is active.

Motor check	In <i>parameter 1-80 Function at Stop</i> , [2] <i>Motor Check</i> was selected. A stop command is active. To ensure that a motor is connected to the drive system, a permanent test current is applied to the motor.
OVC control	Overvoltage control was activated in <i>parameter 2-17 Over-voltage Control</i> , [2] <i>Enabled</i> . The connected motor is supplying the drive system with generative energy. The overvoltage control adjusts the V/Hz ratio to run the motor in controlled mode and to prevent the drive system from tripping.
PowerUnit Off	(Only for drive systems with a 24 V external supply installed.) Mains supply to the drive system is removed, but the control card is supplied by the external 24 V power source. This status indication can also be caused if the drive module's power card is not connected to the drive system's MDCIC card.
Protection md	Protection mode is active. The unit has detected a critical status (an overcurrent or overvoltage). <ul style="list-style-type: none"> To avoid tripping, switching frequency is reduced to 1500 kHz if <i>Parameter 14-55 Output Filter</i> is set to [2] <i>Sine-Wave Filter Fixed</i>. Otherwise, the switching frequency is reduced to 1000 Hz. If possible, protection mode ends after approximately 10 s. Protection mode can be restricted in <i>parameter 14-26 Trip Delay at Inverter Fault</i>.
QStop	The motor is decelerating using <i>parameter 3-81 Quick Stop Ramp Time</i> . <ul style="list-style-type: none"> Quick stop inverse was selected as a function for a digital input (<i>parameter group 5-1* Digital Inputs</i>). The corresponding terminal is not active. The quick stop function was activated via serial communication.
Ramping	The motor is accelerating/decelerating using the active ramp up/down. The reference, a limit value, or a standstill is not yet reached.
Ref. high	The sum of all active references is above the reference limit set in <i>parameter 4-55 Warning Reference High</i> .
Ref. low	The sum of all active references is below the reference limit set in <i>parameter 4-54 Warning Reference Low</i> .
Run on ref.	The drive system is running in the reference range. The feedback value matches the setpoint value.
Run request	A start command has been given, but the motor is stopped until a run permissive signal is received via digital input.
Running	The drive system is driving the motor.

Sleep Mode	The energy saving function is enabled. This function being enabled means that now the motor has stopped, but that it restarts automatically when required.
Speed high	Motor speed is above the value set in <i>parameter 4-53 Warning Speed High</i> .
Speed low	Motor speed is below the value set in <i>parameter 4-52 Warning Speed Low</i> .
Standby	In auto-on mode, the drive system starts the motor with a start signal from a digital input or serial communication.
Start delay	In <i>parameter 1-71 Start Delay</i> , a delay starting time was set. A start command is activated and the motor starts after the start delay time expires.
Start fwd/rev	Start forward and start reverse were selected as functions for 2 different digital inputs (<i>parameter group 5-1* Digital Inputs</i>). The motor starts in forward or reverse depending on which corresponding terminal is activated.
Stop	The drive system has received a stop command from 1 of the following: <ul style="list-style-type: none"> LCP. Digital input. Serial communication.
Trip	An alarm occurred and the motor is stopped. Once the cause of the alarm is cleared, the drive system is reset manually by 1 of the following: <ul style="list-style-type: none"> Pressing [Reset]. Remotely by control terminals. Via serial communication. Pressing [Reset] or remotely by control terminals or via serial communication.
Trip lock	An alarm occurred and the motor is stopped. Once the cause of the alarm is cleared, power must be cycled to the drive system. The drive system is then reset manually by 1 of the following: <ul style="list-style-type: none"> Pressing [Reset]. Remotely by control terminals. Via serial communication.

Table 6.3 Operation Status

NOTICE

In auto/remote mode, the drive system requires external commands to execute functions.

6.4 Warning and Alarm Types

Warning/ alarm type	Description
Warning	A warning indicates an abnormal operating condition that leads to an alarm. A warning stops when the abnormal condition is removed.
Alarm	An alarm indicates a fault that requires immediate attention. The fault always triggers a trip or trip lock. Reset the drive after an alarm. Reset the drive in any of 4 ways: <ul style="list-style-type: none"> • Press [Reset]/[Off/Reset]. • Digital reset input command. • Serial communication reset input command. • Auto reset.

Trip

When tripping, the drive suspends operation to prevent damage to the drive and other equipment. When a trip occurs, the motor coasts to a stop. The drive logic continues to operate and monitor the drive status. After the fault condition is remedied, the drive is ready for a reset.

Trip lock

When trip locking, the drive suspends operation to prevent damage to the drive and other equipment. When a trip lock occurs, the motor coasts to a stop. The drive logic continues to operate and monitor the drive status. The drive starts a trip lock only when serious faults occur that can damage the drive or other equipment. After the faults are fixed, cycle the input power before resetting the drive.

Warning and alarm displays

- A warning is displayed in the LCP along with the warning number.
- An alarm flashes along with the alarm number.

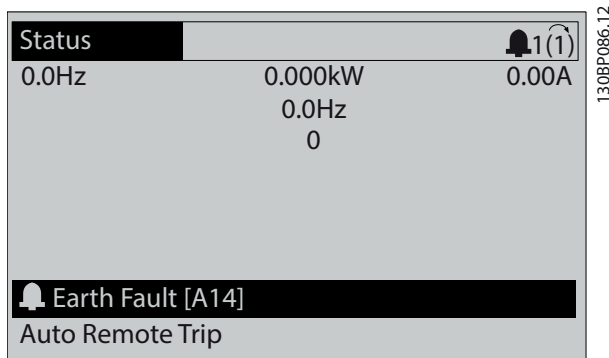
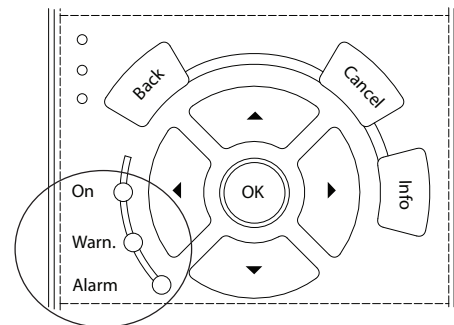

Illustration 6.2 Alarm Display Example

In addition to the text and alarm code in the LCP, there are 3 status indicator lights.



System status	Warning indicator light	Alarm indicator light
Warning	On	Off
Alarm	Off	On (flashing)
Trip lock	On	On (flashing)

Illustration 6.3 Status Indicator Lights

6.5 List of Warnings and Alarms

6.5.1 Warnings/Alarm Messages

A warning or an alarm is signalled by the relevant indicator light on the front of the frequency converter and indicated by a code on the display.

A warning remains active until its cause is no longer present. Under certain circumstances, operation of the motor may still be continued. Warning messages may be critical, but are not necessarily so.

In the event of an alarm, the frequency converter trips. Reset the alarm to resume operation once the cause has been rectified.

3 ways to reset:

- Press [Reset].
- Via a digital input with the reset function.
- Via serial communication/optional fieldbus.

NOTICE

After a manual reset pressing [Reset], press [Auto On] to restart the motor.

If an alarm cannot be reset, the reason may be that its cause has not been rectified, or the alarm is trip locked (see also Table 6.4).

Alarms that are trip locked offer extra protection, meaning that the mains supply must be switched off before the alarm can be reset. After being switched back on, the

frequency converter is no longer blocked and can be reset once the cause has been rectified.

Alarms that are not trip locked can also be reset using the automatic reset function in *parameter 14-20 Reset Mode* (Warning: Automatic wake-up is possible.)

If a warning or alarm is marked against a code in *Table 6.4*, this means that either a warning occurs before an alarm, or it is possible to specify whether a warning or an alarm should be shown for a given fault.

This is possible, for instance, in *parameter 1-90 Motor Thermal Protection*. After an alarm or trip, the motor carries on coasting, and the alarm and warning flash. Once the problem has been rectified, only the alarm continues flashing until the frequency converter is reset.

NOTICE

No missing motor phase detection (numbers 30-32) and no stall detection are active when *parameter 1-10 Motor Construction* is set to [1] PM non-salient SPM.

Number	Description	Warning	Alarm/ Trip	Alarm/ Trip Lock	Parameter Reference
1	10 volts low	X	-	-	
2	Live zero error	(X)	(X)	-	<i>Parameter 6-01 Live Zero Timeout Function</i>
3	No motor	(X)	-	-	<i>Parameter 1-80 Function at Stop</i>
4	Mains phase loss	(X)	(X)	(X)	<i>Parameter 14-12 Response to Mains Imbalance</i>
5	DC-link voltage high	X	-	-	-
6	DC-link voltage low	X	-	-	-
7	DC overvoltage	X	X	-	-
8	DC undervoltage	X	X	-	-
9	Inverter overloaded	X	X	-	-
10	Motor ETR overtemperature	(X)	(X)	-	<i>Parameter 1-90 Motor Thermal Protection</i>
11	Motor thermistor overtemperature	(X)	(X)	-	<i>Parameter 1-90 Motor Thermal Protection</i>
12	Torque limit	X	X	-	-
13	Overcurrent	X	X	X	-
14	Ground fault	X	X	-	-
15	Hardware mismatch	-	X	X	-
16	Short circuit	-	X	X	-
17	Control word timeout	(X)	(X)	-	<i>Parameter 8-04 Control Word Timeout Function</i>
20	Temp. input error	-	X	-	-
21	Param error	-	-	X	-
22	Hoist mech. brake	(X)	(X)	-	<i>Parameter group 2-2* Mechanical Brake</i>
23	Internal fans	X	-	-	-
24	External fans	X	-	-	-
25	Brake resistor short-circuited	X	-	-	-
26	Brake resistor power limit	(X)	(X)	-	<i>Parameter 2-13 Brake Power Monitoring</i>
27	Brake chopper short-circuited	X	X	-	
28	Brake check	(X)	(X)	-	<i>Parameter 2-15 Brake Check</i>
29	Heat sink temp	X	X	X	
30	Motor phase U missing	(X)	(X)	(X)	<i>Parameter 4-58 Missing Motor Phase Function</i>
31	Motor phase V missing	(X)	(X)	(X)	<i>Parameter 4-58 Missing Motor Phase Function</i>
32	Motor phase W missing	(X)	(X)	(X)	<i>Parameter 4-58 Missing Motor Phase Function</i>
33	Inrush fault		X	X	-
34	Fieldbus communication fault	X	X	-	-
35	Option fault	-	-	X	-
36	Mains failure	X	X	-	-
37	Imbalance of supply voltage		X	-	-
38	Internal fault		X	X	-

Number	Description	Warning	Alarm/ Trip	Alarm/ Trip Lock	Parameter Reference
39	Heat sink sensor		X	X	–
40	Overload of digital output terminal 27	(X)	–	–	<i>Parameter 5-00 Digital I/O Mode, parameter 5-01 Terminal 27 Mode</i>
41	Overload of digital output terminal 29	(X)	–	–	<i>Parameter 5-00 Digital I/O Mode, parameter 5-02 Terminal 29 Mode</i>
42	Ovrlid X30/6-7	(X)	–	–	–
43	Ext. supply (option)	X	–	–	–
45	Ground fault 2	X	X	–	–
46	Pwr. card supply	–	X	X	–
47	24 V supply low	X	X	X	–
48	1.8 V supply low	–	X	X	–
49	Speed limit	–	X	–	<i>Parameter 1-86 Trip Speed Low [RPM]</i>
50	AMA calibration failed	–	X	–	–
51	AMA check U_{nom} and I_{nom}	–	X	–	–
52	AMA low I_{nom}	–	X	–	–
53	AMA motor too big	–	X	–	–
54	AMA motor too small	–	X	–	–
55	AMA parameter out of range	–	X	–	–
56	AMA interrupted by user	–	X	–	–
57	AMA time-out	–	X	–	–
58	AMA internal fault	X	X	–	–
59	Current limit	X		–	–
60	External interlock	X	X	–	–
61	Feedback error	(X)	(X)	–	<i>Parameter 4-30 Motor Feedback Loss Function</i>
62	Output frequency at maximum limit	X	–	–	
63	Mechanical brake low		(X)	–	<i>Parameter 2-20 Release Brake Current</i>
64	Voltage limit	X	–	–	–
65	Control board overtemperature	X	X	X	–
66	Heat sink temperature low	X		–	–
67	Option configuration has changed	–	X	–	–
68	Safe stop	(X)	(X) ¹⁾	–	<i>Parameter 5-19 Terminal 37 Safe Stop</i>
69	Pwr. card temp	–	X	X	–
70	Illegal FC configuration	–	–	X	–
71	PTC 1 Safe Stop	–	X	–	–
72	Dangerous failure	–		X	–
73	Safe Stop Auto Restart	(X)	(X)	–	<i>Parameter 5-19 Terminal 37 Safe Stop</i>
74	PTC Thermistor	–	–	X	–
75	Illegal Profile Sel.	–	X	–	–
76	Power unit setup	X	–	–	–
77	Reduced power mode	X	–	–	<i>Parameter 14-59 Actual Number of Inverter Units</i>
78	Tracking error	(X)	(X)	–	<i>Parameter 4-34 Tracking Error Function</i>
79	Illegal PS config	–	X	X	
80	Frequency converter Initialized to default value	–	X	–	–
81	CSIV corrupt	–	X	–	–
82	CSIV parameter error	–	X	–	–
83	Illegal option combination	–	–	X	–
84	No safety option	–	X	–	–
88	Option detection	–	–	X	–
89	Mechanical brake sliding	X	–	–	–
90	Feedback monitor	(X)	(X)	–	<i>Parameter 17-61 Feedback Signal Monitoring</i>

Number	Description	Warning	Alarm/ Trip	Alarm/ Trip Lock	Parameter Reference
91	Analog input 54 wrong settings	–	–	X	S202
99	Locked rotor	–	X	X	–
101	Speed monitor	X	X	–	–
104	Mixing fans	X	X	–	–
122	Mot. rotat. unexp.	–	X	–	–
123	Motor mod. changed	–	X	–	–
163	ATEX ETR cur.lim.warning	X	–	–	–
164	ATEX ETR cur.lim.alarm	–	X	–	–
165	ATEX ETR freq.lim.warning	X	–	–	–
166	ATEX ETR freq.lim.alarm	–	X	–	–
210	Position tracking	X	X	–	<i>Parameter 4-70 Position Error Function, parameter 4-71 Maximum Position Error, parameter 4-72 Position Error Timeout</i>
211	Position limit	X	X	–	<i>Parameter 3-06 Minimum Position, parameter 3-07 Maximum Position, parameter 4-73 Position Limit Function</i>
212	Homing not done	–	X	–	<i>Parameter 17-80 Homing Function</i>
213	Homing timeout	–	X	–	<i>Parameter 17-85 Homing Timeout</i>
214	No sensor input	–	X	–	–
220	Configuration File Version not supported	X	–	–	–
246	Pwr.card supply	–	–	X	–
250	New spare part	–	–	X	–
251	New type code	–	X	X	–
430	PWM Disabled	–	X	–	–

Table 6.4 Alarm/Warning Code List

(X) Dependent on parameter.

1) Cannot be auto reset via parameter 14-20 Reset Mode.

A trip is the action following an alarm. The trip coasts the motor and is reset by pressing [Reset] or by a digital input (*parameter group 5-1* Digital Inputs*). The original event that caused an alarm cannot damage the frequency converter or cause dangerous conditions. A trip lock is an action when an alarm occurs, which could damage the frequency converter or connected parts. A trip lock situation can only be reset by a power cycling.

Warning	Yellow
Alarm	Flashing red
Trip locked	Yellow and red

Table 6.5 Indicator Light

Bit	Hex	Dec	Alarm word	Alarm word 2	Warning word	Warning word 2	Extended status word
Alarm Word Extended Status Word							
0	00000001	1	Brake check (A28)	Servicetrip, read/write	Brake check (W28)	Start delayed	Ramping
1	00000002	2	Pwr.card temp (A69)	Servicetrip, (reserved)	Pwr.card temp (A69)	Stop delayed	AMA running
2	00000004	4	Earth fault (A14)	Servicetrip, typecode/sparepart	Earth fault (W14)	Reserved	Start CW/CCW start_possible is active, when the DI selections [12] OR [13] are active and the requested direction matches the reference sign
3	00000008	8	Ctrl.card temp (A65)	Servicetrip, (reserved)	Ctrl.card temp (W65)	Reserved	Slow down slow down command active, for example via CTW bit 11 or DI
4	00000010	16	Ctrl. word TO (A17)	Servicetrip, (reserved)	Ctrl. word TO (W17)		Catch up catch up command active, for example via CTW bit 12 or DI
5	00000020	32	Overcurrent (A13)	Reserved	Overcurrent (W13)	Reserved	Feedback high feedback >parameter 4-57 Warning <i>Feedback High</i>
6	00000040	64	Torque limit (A12)	Reserved	Torque limit (W12)	Reserved	Feedback low feedback <parameter 4-56 Warning <i>Feedback Low</i>
7	00000080	128	Motor th over (A11)	Reserved	Motor th over (W11)	Reserved	Output current high current >parameter 4-51 Warning <i>Current High</i>
8	00000100	256	Motor ETR over (A10)	Reserved	Motor ETR over (W10)	Reserved	Output current low current <parameter 4-50 Warning <i>Current Low</i>
9	00000200	512	Inverter overl. (A9)	Discharge high	Inverter Overld (W9)	Discharge high	Output freq high speed >parameter 4-53 Warning <i>Speed High</i>
10	00000400	1024	DC under volt (A8)	Start failed	DC under volt (W8)	Multi-motor underload	Output freq low speed <parameter 4-52 Warning <i>Speed Low</i>
11	00000800	2048	DC over volt (A7)	Speed limit	DC over volt (W7)	Multi-motor overload	Brake check OK brake test NOT OK
12	00001000	4096	Short circuit (A16)	External interlock	DC voltage low (W6)	Compressor interlock	Braking max. BrakePower > Brakepowerlimit (2-12)
13	00002000	8192	Inrush fault (A33)	Illegal option combi.	DC voltage high (W5)	Mechanical brake sliding	Braking
14	00004000	16384	Mains ph. loss (A4)	No safety option	Mains ph. loss (W4)	Safe option warning	Out of speed range
15	00008000	32768	AMA not OK	Reserved	No motor (W3)	Auto DC braking	OVC active
16	00010000	65536	Live zero error (A2)	Reserved	Live zero error (W2)		AC brake
17	00020000	131072	Internal fault (A38)	KTY error	10 V low (W1)	KTY warn	Password timelock number of allowed password trials exceeded - timelock active
18	00040000	262144	Brake overload (A26)	Fans error	Brake overload (W26)	Fans warn	Password protection 0-61 = ALL_NO_ACCESS OR BUS_NO_ACCESS OR BUS_READONLY

Bit	Hex	Dec	Alarm word	Alarm word 2	Warning word	Warning word 2	Extended status word
19	00080000	524288	U phase loss (A30)	ECB error	Brake resistor (W25)	ECB warn	Reference high reference >parameter 4-55 Warning Reference High
20	00100000	1048576	V phase loss (A31)	Hoist mechanical brake (A22)	Brake IGBT (W27)	Hoist mechanical brake (W22)	Reference low reference <parameter 4-54 Warning Reference Low
21	00200000	2097152	W phase Loss (A32)	Reserved	Speed limit (W49)	Reserved	Local reference reference site = REMOTE -> auto on pressed & active
22	00400000	4194304	Fieldbus fault (A34)	Reserved	Fieldbus fault (W34)	Reserved	Protection mode notification
23	00800000	8388608	24 V supply low (A47)	Reserved	24 V supply Low (W47)	Reserved	Unused
24	01000000	16777216	Mains failure (A36)	Reserved	Mains failure (W36)	Reserved	Unused
25	02000000	33554432	1.8 V supply low (A48)	Current limit (A59)	Current limit (W59)	Reserved	Unused
26	04000000	67108864	Brake resistor (A25)	Motor rotating unexpectedly (A122)	Low temp (W66)	Reserved	Unused
27	08000000	134217728	Brake IGBT (A27)	Reserved	Voltage limit (W64)	Reserved	Unused
28	10000000	268435456	Option change (A67)	Reserved	Encoder loss (W90)	Reserved	Unused
29	20000000	536870912	Drive initialized (A80)	Encoder loss (A90)	Output freq. lim. (W62)	BackEMF too high	Unused
30	40000000	1073741824	Safe stop (A68)	PTC thermistor (A74)	Safe stop (W68)	PTC thermistor (W74)	Unused
31	80000000	2147483648	Mech. brake low (A63)	Dangerous failure (A72)	Extended status word		Protection mode

Table 6.6 Description of Alarm Word, Warning Word, and Extended Status Word

The alarm words, warning words and extended status words can be read out via a serial bus or optional fieldbus for diagnostics. See also *parameter 16-94 Ext. Status Word*.

WARNING 1, 10 Volts low

The control card voltage is less than 10 V from terminal 50. Remove some of the load from terminal 50, as the 10 V supply is overloaded. Maximum 15 mA or minimum 590 Ω.

A short circuit in a connected potentiometer or incorrect wiring of the potentiometer can cause this condition.

Troubleshooting

- Remove the wiring from terminal 50. If the warning clears, the problem is with the wiring. If the warning does not clear, replace the control card.

WARNING/ALARM 2, Live zero error

This warning or alarm only appears if it is programmed in *parameter 6-01 Live Zero Timeout Function*. The signal on 1 of the analog inputs is less than 50% of the minimum value programmed for that input. Broken wiring or a faulty device sending the signal can cause this condition.

Troubleshooting

- Check the connections on all the analog mains terminals:
 - Control card terminals 53 and 54 for signals, terminal 55 common.
 - VLT® General Purpose I/O MCB 101 option terminals 11 and 12 for signals, terminal 10 common.
 - VLT® Analog I/O MCB 109 option terminals 1, 3, and 5 for signals, terminals 2, 4, and 6 common.
- Check that the drive system's programming and switch settings match the analog signal type.
- Perform an input terminal signal test.

WARNING/ALARM 3, No motor

No motor has been connected to the output of the drive system.

WARNING/ALARM 4, Mains phase loss

A phase is missing on the supply side, or the mains voltage imbalance is too high. This message also appears for a fault in the input rectifier on the drive system. Options are programmed in *parameter 14-12 Function at Mains Imbalance*.

Troubleshooting

- Check the supply voltage and supply currents to the drive system.

WARNING 5, DC link voltage high

The DC-link voltage (DC) is higher than the high-voltage warning limit. The limit depends on the drive system's voltage rating. The unit is still active.

WARNING 6, DC link voltage low

The DC-link voltage (DC) is lower than the low-voltage warning limit. The limit depends on the drive system's voltage rating. The unit is still active.

WARNING/ALARM 7, DC overvoltage

If the voltage in the intermediate circuit exceeds the limit, the drive system trips after a time.

Troubleshooting

- Extend the ramp time.
- Change the ramp type.
- Increase *parameter 14-26 Trip Delay at Inverter Fault*.
- Check that the supply voltage matches the voltage at the drive system.
- Perform an input voltage test.

WARNING/ALARM 8, DC under voltage

If the voltage in the intermediate circuit (DC-link) drops below the undervoltage limit, the drive system checks if a 24 V DC back-up power supply is connected. If a 24 V DC back-up power supply is not connected, the drive system trips after a fixed time delay. The time delay varies with the size of the drive system.

Troubleshooting

- Check that the supply voltage matches the voltage at the drive system.
- Perform an input voltage test.
- Perform a soft charge circuit test.
- Check if the DC fans are not running. DC fans are designed to run for only a short time when powered on into standby mode.

WARNING/ALARM 9, Inverter overload

The drive system has run with more than 100% overload for too long and is about to cut out. The counter for electronic thermal inverter protection issues a warning at 98% and trips at 100%, while giving an alarm. The drive system cannot be reset until the counter is again below 90%.

Troubleshooting

- Compare the output current shown on the LCP with the drive system's rated current.
- Compare the output current shown on the LCP with the measured motor current.
- Show the thermal load of the drive system on the LCP and monitor the value. When running above the drive system's continuous current rating, the counter increases. When running below the continuous current rating, the counter decreases.

WARNING/ALARM 10, Motor overload temperature

According to the electronic thermal protection (ETR), the motor is too hot. Select whether the frequency converter issues a warning or an alarm when the counter is >90% if *parameter 1-90 Motor Thermal Protection* is set to warning

options, or whether the frequency converter trips when the counter reaches 100% if *parameter 1-90 Motor Thermal Protection* is set to trip options. The fault occurs when the motor runs with more than 100% overload for too long.

Troubleshooting

- Check for motor overheating.
- Check if the motor is mechanically overloaded.
- Check that the motor current set in *parameter 1-24 Motor Current* is correct.
- Ensure that the motor data in *parameters 1-20 to 1-25* are set correctly.
- If an external fan is in use, check that it is selected in *parameter 1-91 Motor External Fan*.
- Running AMA in *parameter 1-29 Automatic Motor Adaptation (AMA)* tunes the frequency converter to the motor more accurately and reduces thermal loading.

WARNING/ALARM 11, Motor thermistor overtemp

Check that the thermistor is not disconnected. In *parameter 1-90 Motor Thermal Protection*, select whether the drive system issues a warning or an alarm.

Troubleshooting

- Check for motor overheating.
- Check if the motor is mechanically overloaded.
- When using terminal 53 or 54, check that the thermistor is connected correctly between either terminal 53 or 54 (analog voltage input) and terminal 50 (+10 V supply). Also check that the terminal switch for 53 or 54, whichever is connected, is set for voltage. Check that *parameter 1-93 Thermistor Source* selects the connected terminal, 53 or 54.
- When using terminal 18, 19, 31, 32, or 33 (digital inputs), check that the thermistor is connected correctly between the digital input terminal used (digital input PNP only) and terminal 50. Select the terminal to use in *parameter 1-93 Thermistor Source*.

WARNING/ALARM 12, Torque limit

The torque has exceeded the value in *parameter 4-16 Torque Limit Motor Mode* or the value in *parameter 4-17 Torque Limit Generator Mode*. *Parameter 14-25 Trip Delay at Torque Limit* can change this warning from a warning-only condition to a warning followed by an alarm.

Troubleshooting

- If the motor torque limit is exceeded during ramp-up, extend the ramp-up time.
- If the generator torque limit is exceeded during ramp-down, extend the ramp-down time.

- If torque limit occurs while running, increase the torque limit. Make sure that the system can operate safely at a higher torque.
- Check the application for excessive current draw on the motor.

WARNING/ALARM 13, Over current

The inverter peak current limit (approximately 200% of the rated current) is exceeded. The warning lasts approximately 1.5 s, then the drive system trips and issues an alarm. Shock loading or quick acceleration with high-inertia loads can cause this fault. If the acceleration during ramp-up is too quick, the fault can also appear after kinetic back-up. If extended mechanical brake control is selected, a trip can be reset externally.

Troubleshooting

- Remove the power and check if the motor shaft can be turned.
- Check that the motor size matches the drive system.
- Check that the motor data is correct in *parameters 1-20 to 1-25*.

ALARM 14, Earth (ground) fault

There is current from the output phase to ground, either in the cable between the drive system and the motor, or in the motor itself. Ground faults are detected by the current transducers that measure the current going out from the drive system and the current going into the drive system from the motor. A ground fault is issued if the deviation of the 2 currents is too large (the current going out of the drive system must be the same as the current going into the drive system).

Troubleshooting

- Remove the power to the drive system and then repair the ground fault.
- Check for ground faults in the motor by measuring the resistance to ground of the motor cables and the motor with a megohmmeter.
- Reset any potential individual offset in the 3 current transducers in the drive module by performing the manual initialization or a complete AMA. This method is most relevant after changing the power card.
- Check the MDCIC on the control shelf for the correct number of current scaling cards. The number of current scaling cards must be equal to the number of connected drive modules in the drive system.
- Check the connections at the current scaling cards on the MDCIC.

ALARM 15, Hardware mismatch

A fitted option is not operational with the present control card hardware or software.

Record the value of the following parameters and contact Danfoss.

- *Parameter 15-40 FC Type.*
- *Parameter 15-41 Power Section.*
- *Parameter 15-42 Voltage.*
- *Parameter 15-43 Software Version.*
- *Parameter 15-45 Actual Typecode String.*
- *Parameter 15-49 SW ID Control Card.*
- *Parameter 15-50 SW ID Power Card.*
- *Parameter 15-60 Option Mounted.*
- *Parameter 15-61 Option SW Version (for each option slot).*

ALARM 16, Short circuit

There is a short circuit in the motor or motor wiring.

Troubleshooting

- Remove the power to the drive system and then repair the short circuit.

WARNING/ALARM 17, Control word timeout

There is no communication with the drive system.

The warning is only active when *parameter 8-04 Control Word Timeout Function* is NOT set to [0] Off.

If *parameter 8-04 Control Word Timeout Function* is set to [5] Stop and Trip, a warning appears, the drive system ramps down until it stops, and then an alarm is displayed.

Troubleshooting

- Check the connections on the serial communication cable.
- Increase *parameter 8-03 Control Word Timeout Time*.
- Check the operation of the communication equipment.
- Verify a proper installation based on EMC requirements.

WARNING/ALARM 22, Hoist mechanical brake

The value of this warning/alarm shows the type of warning/alarm.

0 = The torque reference was not reached before timeout (*parameter 2-27 Torque Ramp Up Time*).

1 = Expected brake feedback was not received before timeout (*parameter 2-23 Activate Brake Delay*, *parameter 2-25 Brake Release Time*).

WARNING 25, Brake resistor short circuit

The brake resistor is monitored during operation. If a short circuit occurs, the brake function is disabled and the warning appears. The drive system is still operational, but without the brake function.

Troubleshooting

- Remove the power to the drive system and then replace the brake resistor (see *parameter 2-15 Brake Check*).

WARNING/ALARM 26, Brake resistor power limit

The power transmitted to the brake resistor is calculated as a mean value over the last 120 s of run time. The calculation is based on the DC-link voltage and the brake resistor value set in *parameter 2-16 AC brake Max. Current*. The warning is active when the dissipated braking power is higher than 90% of the brake resistor power. If option [2] Trip is selected in *parameter 2-13 Brake Power Monitoring*, the drive system trips when the dissipated braking power reaches 100%.

WARNING/ALARM 27, Brake chopper fault

The brake transistor is monitored during operation, and if a short circuit occurs, the brake function is disabled and a warning is issued. The drive system is still operational, but since the brake transistor has short-circuited, substantial power is transmitted to the brake resistor, even if it is inactive.

Troubleshooting

- Remove power to the drive system and then remove the brake resistor.

WARNING/ALARM 28, Brake check failed

The brake resistor is not connected or not working.

Troubleshooting

- Check *parameter 2-15 Brake Check*.

ALARM 29, Heat sink temp

The maximum temperature of the heat sink has been exceeded. The temperature fault does not reset until the temperature drops below a defined heat sink temperature. The trip and reset points are different, based on the drive system's power size.

Troubleshooting

Check for the following conditions:

- Ambient temperature too high.
- Motor cables too long.
- Incorrect airflow clearance above and below the drive system.
- Blocked airflow around the drive system.
- Damaged heat sink fan.
- Dirty heat sink.

ALARM 30, Motor phase U missing

Motor phase U between the drive system and the motor is missing.

Troubleshooting

- Remove the power from the drive system and then check motor phase U.

ALARM 31, Motor phase V missing

Motor phase V between the drive system and the motor is missing.

Troubleshooting

- Remove the power from the drive system and then check motor phase V.

ALARM 32, Motor phase W missing

Motor phase W between the drive system and the motor is missing.

Troubleshooting

- Remove the power from the drive system and then check motor phase W.

ALARM 33, Inrush fault

Too many power-ups have occurred within a short time period.

Troubleshooting

- Let the unit cool to operating temperature.

WARNING/ALARM 34, Fieldbus communication fault

The fieldbus on the communication option card is not working.

WARNING/ALARM 36, Mains failure

This warning/alarm is only active if the supply voltage to the drive system is lost and *parameter 14-10 Mains Failure* is not set to option [0] *No Function*.

- Check the fuses to the drive system and the mains supply to the unit.
- Check that mains voltage conforms to product specifications.
- Check that the following conditions are not present:
Alarm 307, Excessive THD(V), alarm 321, Voltage imbalance, warning 417, Mains undervoltage, or warning 418, Mains overvoltage is reported if any of the listed conditions are true:
 - The 3-phase voltage magnitude drops below 25% of the nominal mains voltage.
 - Any single-phase voltage exceeds 10% of the nominal mains voltage.
 - Percent of phase or magnitude imbalance exceeds 8%.
 - Voltage THD exceeds 10%.

ALARM 38, Internal fault

When an internal fault occurs, a code number defined in *Table 6.7* is shown.

Troubleshooting

- Cycle power.
- Check that the option is properly installed.
- Check for loose or missing wiring.

It may be necessary to contact the Danfoss supplier or service department. Note the code number for further troubleshooting directions.

Number	Text
0	The serial port cannot be initialized. Contact the Danfoss supplier or Danfoss service department.
256–258	The power EEPROM data is defective or too old. Replace the power card.
512–519	Internal fault. Contact the Danfoss supplier or Danfoss service department.
783	Parameter value outside of minimum/maximum limits.
1024–1284	Internal fault. Contact the Danfoss supplier or Danfoss service department.
1299	The option software in slot A is too old.
1300	The option software in slot B is too old.
1302	The option software in slot C1 is too old.
1315	The option software in slot A is not supported/allowed.
1316	The option software in slot B is not supported/allowed.
1318	The option software in slot C1 is not supported/allowed.
1379–2819	Internal fault. Contact the Danfoss supplier or Danfoss service department.
1792	Hardware reset of digital signal processor.
1793	Motor-derived parameters not transferred correctly to the digital signal processor.
1794	Power data not transferred correctly at power-up to the digital signal processor.
1795	The digital signal processor has received too many unknown SPI telegrams. The frequency converter also uses this fault code if the MCO does not power up correctly. This situation can occur due to poor EMC protection or improper grounding.
1796	RAM copy error.
2561	Replace the control card.
2820	LCP stack overflow.
2821	Serial port overflow.
2822	USB port overflow.
3072–5122	Parameter value is outside its limits.
5123	Option in slot A: Hardware incompatible with the control board hardware.
5124	Option in slot B: Hardware incompatible with the control board hardware.
5125	Option in slot C0: Hardware incompatible with the control board hardware.
5126	Option in slot C1: Hardware incompatible with the control board hardware.
5376–6231	Internal fault. Contact the Danfoss supplier or Danfoss service department.

Table 6.7 Internal Fault Codes

ALARM 39, Heat sink sensor

No feedback from the heat sink temperature sensor.

The signal from the IGBT thermal sensor is not available on the power card. The problem could be on the power card,

on the gatedrive card, or the ribbon cable between the power card and gatedrive card.

WARNING 40, Overload of digital output terminal 27

Check the load connected to terminal 27 or remove the short-circuit connection. Check *parameter 5-00 Digital I/O Mode* and *parameter 5-01 Terminal 27 Mode*.

WARNING 41, Overload of digital output terminal 29

Check the load connected to terminal 29 or remove the short-circuit connection. Also check *parameter 5-00 Digital I/O Mode* and *parameter 5-02 Terminal 29 Mode*.

WARNING 42, Overload of digital output on X30/6 or overload of digital output on X30/7

For terminal X30/6, check the load connected to terminal X30/6 or remove the short-circuit connection. Also check *parameter 5-32 Term X30/6 Digi Out (MCB 101)* (VLT® General Purpose I/O MCB 101).

For terminal X30/7, check the load connected to terminal X30/7 or remove the short-circuit connection. Check *parameter 5-33 Term X30/7 Digi Out (MCB 101)* (VLT® General Purpose I/O MCB 101).

ALARM 43, Ext. supply

VLT® Extended Relay Option MCB 113 is mounted without external 24 V DC. Either connect a 24 V DC external supply or specify that no external supply is used via *parameter 14-80 Option Supplied by External 24VDC, [0] No.* A change in *parameter 14-80 Option Supplied by External 24VDC* requires a power cycle.

ALARM 45, Earth fault 2

Ground fault.

Troubleshooting

- Check for proper grounding and loose connections.
- Check for proper wire size.
- Check the motor cables for short circuits or leakage currents.

ALARM 46, Power card supply

The supply on the power card is out of range. Another reason can be a defective heat sink fan.

There are 3 supplies generated by the switch mode supply (SMPS) on the power card:

- 24 V.
- 5 V.
- ± 18 V.

When powered with VLT® 24 V DC Supply MCB 107, only the 24 V and 5 V supplies are monitored. When powered with 3-phase mains voltage, all 3 supplies are monitored.

Troubleshooting

- Check for a defective power card.
- Check for a defective control card.
- Check for a defective option card.

- If a 24 V DC supply is used, verify proper supply power.
- Check for a defective heat sink fan.

WARNING 47, 24 V supply low

The supply on the power card is out of range.

There are 3 supplies generated by the switch mode supply (SMPS) on the power card:

- 24 V.
- 5 V.
- ± 18 V.

Troubleshooting

- Check for a defective power card.

WARNING 48, 1.8 V supply low

The 1.8 V DC supply used on the control card is outside of the allowable limits. The supply is measured on the control card.

Troubleshooting

- Check for a defective control card.
- If an option card is present, check for overvoltage.

WARNING 49, Speed limit

When the speed is outside the specified range in *parameter 4-11 Motor Speed Low Limit [RPM]* and *parameter 4-13 Motor Speed High Limit [RPM]*, the drive system shows a warning. When the speed is below the specified limit in *parameter 1-86 Trip Speed Low [RPM]* (except when starting or stopping), the drive system trips.

ALARM 50, AMA calibration failed

Contact the Danfoss supplier or Danfoss service department.

ALARM 51, AMA check U_{nom} and I_{nom}

The settings for motor voltage, motor current, and motor power are wrong.

Troubleshooting

- Check the settings in *parameters 1-20 to 1-25*.

ALARM 52, AMA low I_{nom}

The motor current is too low.

Troubleshooting

- Check the settings in *parameter 1-24 Motor Current*.

ALARM 53, AMA motor too big

The motor is too large for the AMA to operate.

ALARM 54, AMA motor too small

The motor is too small for the AMA to operate.

ALARM 55, AMA parameter out of range

The AMA cannot run because the parameter values of the motor are outside of the acceptable range.

ALARM 56, AMA interrupted by user

The AMA is manually interrupted.

ALARM 57, AMA internal fault

Try to restart the AMA. Repeated restarts can overheat the motor.

ALARM 58, AMA Internal fault

Contact the Danfoss supplier.

WARNING 59, Current limit

The current is higher than the value in *parameter 4-18 Current Limit*. Ensure that the motor data in *parameters 1-20 to 1-25* is set correctly. Increase the current limit if necessary. Ensure that the system can operate safely at a higher limit.

WARNING 60, External interlock

A digital input signal is indicating a fault condition external to the drive system. An external interlock has commanded the drive system to trip. Clear the external fault condition. To resume normal operation, apply 24 V DC to the terminal programmed for external interlock. Reset the drive system.

WARNING/ALARM 61, Feedback error

An error between calculated speed and speed measurement from feedback device.

Troubleshooting

- Check the settings for warning/alarm/disabling in *parameter 4-30 Motor Feedback Loss Function*.
- Set the tolerable error in *parameter 4-31 Motor Feedback Speed Error*.
- Set the tolerable feedback loss time in *parameter 4-32 Motor Feedback Loss Timeout*.

WARNING 62, Output frequency at maximum limit

The output frequency has reached the value set in *parameter 4-19 Max Output Frequency*. Check the application for possible causes. Possibly increase the output frequency limit. Be sure that the system can operate safely at a higher output frequency. The warning clears when the output drops below the maximum limit.

WARNING/ALARM 65, Control card over temperature

The cutout temperature of the control card is 85 °C (185 °F).

Troubleshooting

- Check that the ambient operating temperature is within the limits.
- Check for clogged filters.
- Check the fan operation.
- Check the control card.

WARNING 66, Heat sink temperature low

The drive system is too cold to operate. This warning is based on the temperature sensor in the IGBT module. Increase the ambient temperature of the unit. Also, a trickle current (a small amount of current) can be supplied to the drive system whenever the motor is stopped by setting *parameter 2-00 DC Hold/Preheat Current* at 5% and *parameter 1-80 Function at Stop*.

ALARM 67, Option module configuration has changed

One or more options have either been added or removed since the last power-down. Check that the configuration change is intentional and reset the unit.

ALARM 68, Safe Stop activated

Safe Torque Off (STO) has been activated. To resume normal operation, apply 24 V DC to terminal 37, then send a reset signal (via bus, digital I/O, or by pressing [Reset]).

ALARM 69, Power card temperature

The temperature sensor on the power card is either too hot or too cold.

Troubleshooting

- Check that the ambient operating temperature is within limits.
- Check for clogged filters.
- Check fan operation.
- Check the power card.

ALARM 70, Illegal FC configuration

The control card and the power card are incompatible. To check compatibility, contact a Danfoss supplier with the type code of the drive system from its nameplate and the part numbers of the cards.

ALARM 71, PTC 1 safe stop

STO has been activated from the VLT® PTC Thermistor Card MCB 112 (motor too warm). Normal operation can be resumed when the MCB 112 applies 24 V DC to terminal 37 again (when the motor temperature reaches an acceptable level), and when the digital input from the MCB 112 is deactivated. When that happens, send a reset signal (via bus or digital I/O, or press [Reset]).

ALARM 72, Dangerous failure

STO with trip lock. An unexpected combination of STO commands has occurred:

- VLT® PTC Thermistor Card MCB 112 enables X44/10, but STO is not enabled.
- MCB 112 is the only device using STO (specified through selection [4] *PTC 1 alarm* or [5] *PTC 1 warning* in *parameter 5-19 Terminal 37 Safe Stop*), STO is activated, and X44/10 is not activated.

WARNING 73, Safe Stop auto restart

STO activated. With automatic restart enabled, the motor can start when the fault is cleared.

WARNING 76, Power unit setup

The required number of power units does not match the detected number of active power units. This warning occurs when replacing a drive module if the power-specific data in the module power card does not match the rest of the drive system. The warning is also triggered if the power card connection is lost.

Troubleshooting

- Confirm that the drive module and its power card have the correct part number.
- Ensure that the 44-pin cables between the MDCIC and power cards are mounted correctly.

WARNING 77, Reduced power mode

This warning indicates that the drive system is operating in reduced power mode (that is, operating with less than the allowed number of inverter sections). This warning is generated on power cycle when the drive system is set to run with fewer inverters and then remains on.

ALARM 79, Illegal power section configuration

The scaling card has an incorrect part number or is not installed. The MK102 connector on the power card could not be installed.

ALARM 80, Drive initialised to default value

Parameter settings are initialized to default settings after a manual reset. To clear the alarm, reset the unit.

ALARM 81, CSIV corrupt

CSIV file has syntax errors.

ALARM 82, CSIV parameter error

CSIV failed to initialize a parameter.

ALARM 85, Dang fail PB

PROFIBUS/PROFIsafe error.

ALARM 91, Analog input 54 wrong settings

Set switch S202 in position OFF (voltage input) when a KTY sensor is connected to analog input terminal 54.

WARNING 98, Clock fault

Time is not set or the RTC clock has failed.

Troubleshooting

- Reset the clock in *parameter 0-70 Date and Time*.

ALARM 243, Brake IGBT

This alarm is only for multi-drive systems. It is equivalent to *alarm 27, Brake chopper fault*. The report value in the alarm log indicates which drive module generated the alarm. This IGBT fault can be caused by any of the following:

- The DC fuse is blown.
- The brake jumper is not in position.
- The Klixon switch opened due to an overtemperature condition in the brake resistor.

The report value in the alarm log indicates which drive module generated the alarm:

- 1 = Left drive module.
- 2 = Second drive module from left.
- 3 = Third drive module from left (in 4-module module systems).
- 4 = Fourth drive module from left (in 4-module module systems).

ALARM 244, Heat sink temperature

The maximum temperature of the heat sink has been exceeded. The temperature fault cannot reset until the temperature drops below a defined heat sink temperature. The trip and reset points are different based on the drive system power size. This alarm is equivalent to *alarm 29, Heat sink temp*. The report value in the alarm log indicates which drive module generated the alarm:

- 1 = Left drive module.
- 2 = Second drive module from left.
- 3 = Third drive module from left (in 4-drive module systems).
- 4 = Fourth drive module from left (in 4-drive module systems).

Troubleshooting

Check for the following conditions:

- Ambient temperature too high.
- Motor cables too long.
- Incorrect airflow clearance above or below the drive system.
- Blocked airflow around the unit.
- Damaged heat sink fan.
- Dirty heat sink.

ALARM 245, Heat sink sensor

No feedback from the heat sink temperature sensor. The signal from the IGBT thermal sensor is not available on the power card. This alarm is equivalent to *alarm 39, Heat sink sensor*. The report value in the alarm log indicates which drive module generated the alarm:

- 1 = Left drive module.
- 2 = Second drive module from left.
- 3 = Third drive module from left (in 4-module module systems).
- 4 = Fourth drive module from left (in 4-module module systems).

Troubleshooting

Check the following:

- Power card.
- Gatedrive card.
- Ribbon cable between the power card and the gatedrive card.

ALARM 246, Power card supply

This alarm is only for multi-drive systems. It is equivalent to *alarm 46, Power card supply*. The report value in the alarm log indicates which drive module generated the alarm:

- 1 = Left drive module.
- 2 = Second drive module from left.

3 = Third drive module from left (in 4-module module systems).

4 = Fourth drive module from left (in 4-module module systems).

ALARM 247, Power card temperature

This alarm is only for multi-drive systems. It is equivalent to *alarm 69, Power card temperature*. The report value in the alarm log indicates which drive module generated the alarm:

1 = Left drive module.

2 = Second drive module from left.

3 = Third drive module from left (in 4-module module systems).

4 = Fourth drive module from left (in 4-module module systems).

ALARM 248, Illegal power section configuration

This alarm is only for multi-drive systems. It is equivalent to *alarm 79, Illegal power section configuration*. The report value in the alarm log indicates which drive module generated the alarm:

1 = Left drive module.

2 = Second drive module from left.

3 = Third drive module from left (in 4-module module systems).

4 = Fourth drive module from left (in 4-module module systems).

Troubleshooting

Check the following:

- The current scaling cards on the MDCIC.

WARNING 250, New spare part

A component in the drive system has been replaced.

Troubleshooting

- Reset the drive system to restore normal operation.

WARNING 251, New typecode

The power card or other components are replaced, and the type code has changed.

6.6 Troubleshooting

6

Symptom	Possible cause	Test	Solution
Display is dark or not functioning	Input power is missing	See the pre-start check list in the <i>VLT® Parallel Drive Modules Installation Instructions</i> .	Check the input power source.
	Fuses are missing or open, or the circuit breaker has tripped	See <i>Open power fuses or tripped circuit breaker</i> in this table for possible causes.	Follow the provided recommendations.
	No power to the LCP	Check the LCP cable for a faulty connection or damage.	Replace the faulty LCP or connection cable.
	Short circuit on the control voltage (terminal 12 or 50) or at control terminals	Check the 24 V control voltage supply for terminals 12/13 to 20–39. Check 10 V supply for terminals 50–55.	Wire the terminals properly.
	Incompatible LCP (LCP from VLT® 2800 or 5000/6000/8000/FCD or FCM)		Use only LCP 101 (P/N 130B1124) or LCP 102 (P/N 130B1107).
	Wrong contrast setting		Press [Status] + [▲]/[▼] to adjust the contrast.
	Defective display (LCP)	Test using a different LCP.	Replace the faulty LCP or connection cable.
	Faulty internal voltage supply or defective SMPS		Contact a Danfoss supplier.
Intermittent display	Overloaded supply (SMPS) due to improper control wiring or a fault within the drive system	To rule out a problem in the control wiring, disconnect all control wiring by removing the terminal blocks.	If the display stays lit, then the problem is in the control wiring. Check the wiring for short circuits or incorrect connections. If the display continues to cut out, follow the procedure for <i>Display is dark or not functioning</i> .
Motor is not running	Service switch is open or the motor connection is missing	Check that the motor is connected and that the connection is not interrupted (by a service switch or other device).	Connect the motor and then check the service switch.
	No mains power with the 24 V DC option card	If the display is functioning but there is no output, check that mains power is applied to the drive system.	Run the unit by applying mains power.
	LCP stop	Check if [Off] has been pressed on the LCP.	Press [Auto On] or [Hand On] (depending on the operating mode) to run the motor.
	Start signal is missing (Standby)	Check <i>parameter 5-10 Terminal 18 Digital Input</i> for the correct setting for terminal 18 (use the default setting).	Start the motor by applying a valid start signal.
	Motor coast signal is active (Coasting)	Check <i>parameter 5-12 Terminal 27 Digital Input</i> for the correct setting for terminal 27 (use the default setting).	Apply 24 V on terminal 27 or program this terminal to <i>No operation</i> .
	Wrong reference signal source	Check reference signal: <ul style="list-style-type: none"> • Local, remote, or bus reference? • Is preset reference active? • Is terminal connection correct? • Is scaling of terminals correct? • Is reference signal available? 	Program the correct settings. Check <i>parameter 3-13 Reference Site</i> . Set the preset reference active in <i>parameter group 3-1* References</i> . Check for correct wiring. Check the terminals for scaling. Check the reference signal.

Symptom	Possible cause	Test	Solution
Motor is running in wrong direction	Motor rotation limit is not programmed correctly.	Check that <i>parameter 4-10 Motor Speed Direction</i> is programmed correctly.	Program the correct settings.
	Active reversing signal is programmed.	Check if a reversing command is programmed for the terminal in <i>parameter group 5-1* Digital inputs</i> .	Deactivate the reversing signal.
	Wrong motor phase connection.		Change the direction of rotation by switching 2 phases in the motor cable, or by changing the setting of <i>parameter 4-10 Motor Speed Direction</i> .
Motor is not reaching maximum speed	Frequency limits are set incorrectly.	Check output limits in <i>parameter 4-13 Motor Speed High Limit [RPM]</i> , <i>parameter 4-14 Motor Speed High Limit [Hz]</i> , and <i>parameter 4-19 Max Output Frequency</i> .	Program the correct limits.
	Reference input signal is not scaled correctly.	Check reference input signal scaling in <i>parameter group 6-0* Analog I/O Mode</i> and <i>3-1* References</i> . Reference limits in <i>parameter group 3-0* Reference Limit</i> .	Program the correct settings.
Motor speed is unstable	Possible incorrect parameter settings.	Check the settings of all motor parameters, including all motor compensation settings. For closed-loop operation, check PID settings.	Check the settings in <i>parameter group 1-6* Load Depen.Setting</i> . For closed-loop operation, check the settings in <i>parameter group 20-0* Feedback</i> .
Motor runs rough	Possible overmagnetization.	Check for incorrect motor settings in all motor parameters.	Check the motor settings in <i>parameter groups 1-2* Motor Data</i> , <i>1-3* Adv Motor Data</i> , and <i>1-5* Load Indep. Setting</i> .
Motor does not brake	Possibly incorrect settings in the brake parameters. Possibly ramp-down times are too short.	Check brake parameters. Check ramp-time settings.	Check <i>parameter groups 2-0* DC Brake</i> and <i>3-0* Reference Limits</i> .
Open power fuses or tripped circuit breaker	Phase-to-phase short.	Motor or panel has a short circuit, phase-to-phase. Check motor and panel phase for short circuits.	Eliminate any detected short circuits.
	Motor overload.	Motor is overloaded for the application.	Perform the startup test and verify that motor current is within specifications. If motor current exceeds the nameplate full load current, the motor runs only with reduced load. Review the specifications for the application.
	Loose connections.	Perform a pre-startup check for loose connections.	Tighten any loose connections.
Mains current imbalance is greater than 3%	Problem with mains power (See <i>alarm 4, Mains phase loss</i> description).	Rotate the input power leads into the drive system 1 position: A to B, B to C, and C to A.	If the imbalanced leg stays on the same power lead, it is a power problem. Check the mains supply.
	Problem with the drive system.	Rotate the input power leads into the drive system 1 position: A to B, B to C, and C to A.	If the imbalanced leg stays on the same input terminal, the problem is in the unit. Contact a Danfoss supplier.
Motor current imbalance is greater than 3%	Problem with the motor or motor wiring.	Rotate the output motor cables 1 position: U to V, V to W, and W to U.	If the imbalanced leg stays on the same output motor cable, the problem is in the motor or motor wiring. Check the motor and motor wiring.
	Problem with the drive system.	Rotate the output motor cables 1 position: U to V, V to W, and W to U.	If the imbalanced leg stays on the same output terminal, the problem is with the unit. Contact a Danfoss supplier.

Symptom	Possible cause	Test	Solution
Drive system has acceleration problems	Motor data are entered incorrectly.	If warnings or alarms occur, see <i>chapter 6.5 List of Warnings and Alarms</i> . Check that motor data are entered correctly.	Increase the ramp-up time in <i>parameter 3-41 Ramp 1 Ramp Up Time</i> . Increase the current limit in <i>parameter 4-18 Current Limit</i> . Increase the torque limit in <i>parameter 4-16 Torque Limit Motor Mode</i> .
Drive system has deceleration problems	Motor data are entered incorrectly.	If warnings or alarms occur, see <i>chapter 6.5 List of Warnings and Alarms</i> . Check that motor data are entered correctly.	Increase the ramp-down time in <i>parameter 3-42 Ramp 1 Ramp Down Time</i> . Enable overvoltage control in <i>parameter 2-17 Overvoltage Control</i> .
Acoustic noise or vibration (for example, a fan blade is making noise or vibrations at certain frequencies)	Excessive resonances, for example, in the motor/fan system.	Bypass critical frequencies, using parameters in the <i>parameter group 4-6* Speed Bypass</i> .	Check if noise and vibration have been reduced to an acceptable level.
		Turn off overmodulation in <i>parameter 14-03 Overmodulation</i> .	
		Change the switching pattern and frequency in the <i>parameter group 14-0* Inverter Switching</i> .	
		Increase resonance damping in <i>parameter 1-64 Resonance Dampening</i> .	

Table 6.8 Troubleshooting

6.7 Running in Reduced Power Mode

If a drive module fails, this function allows the drive system to run in reduced power mode until the failed drive module is replaced. In accordance with the reduced capability, the protection limits and working limits are scaled down.

Before configuring the drive for reduced power mode, read and understand the following safety guidelines.

6.7.1 Safety

Only qualified personnel should install and service the VLT® Parallel Drive Modules.

Qualified personnel are defined as trained staff, who are authorized to install equipment, systems, and circuits in accordance with pertinent laws and regulations. Also, the personnel must be familiar with the instructions and safety measures described in this manual.

⚠ WARNING

HIGH VOLTAGE

The drive system contains high voltage when connected to AC mains input, DC supply, or load sharing. Failure to perform installation, startup, and maintenance by qualified personnel can result in death or serious injury.

- Only qualified personnel must perform installation, startup, and maintenance.

⚠ WARNING

UNINTENDED MOTOR ROTATION WINDMILLING

Unintended rotation of permanent magnet motors creates voltage and can charge the capacitors in the drive system, resulting in death, serious injury, or equipment damage.

- Ensure that permanent magnet motors are blocked to prevent unintended rotation.

⚠ WARNING

DISCHARGE TIME

The drive module contains DC-link capacitors. Once mains power has been applied to the drive, these capacitors can remain charged even after the power has been removed. High voltage can be present even when the warning indicator lights are off. Failure to wait 20 minutes after power has been removed before performing service or repair work can result in death or serious injury.

- Stop the motor.
- Disconnect AC mains and remote DC-link supplies, including battery back-ups, UPS, and DC-link connections to other drives.
- Disconnect or lock the PM motor.
- Wait 20 minutes for the capacitors to discharge fully before performing any service or repair work.

⚠ WARNING

EQUIPMENT HAZARD

Contact with rotating shafts and electrical equipment can result in death or serious injury.

- Ensure that only trained and qualified personnel perform the installation.
- Ensure that electrical work conforms to national and local electrical codes.
- Follow the procedures in this manual.

⚠ WARNING

DISCONNECT POWER BEFORE SERVICING

Sometimes during installation, AC mains power is applied but then must be disconnected to change the line connections. Failure to follow these steps can result in death or serious injury.

- Disconnect the frequency converters from the AC mains, 230 V supply, and motor lines.
- After the lines have been disconnected, wait 20 minutes for the capacitors to discharge.

6.7.2 Configuring the Drive System for Reduced Power Mode

6

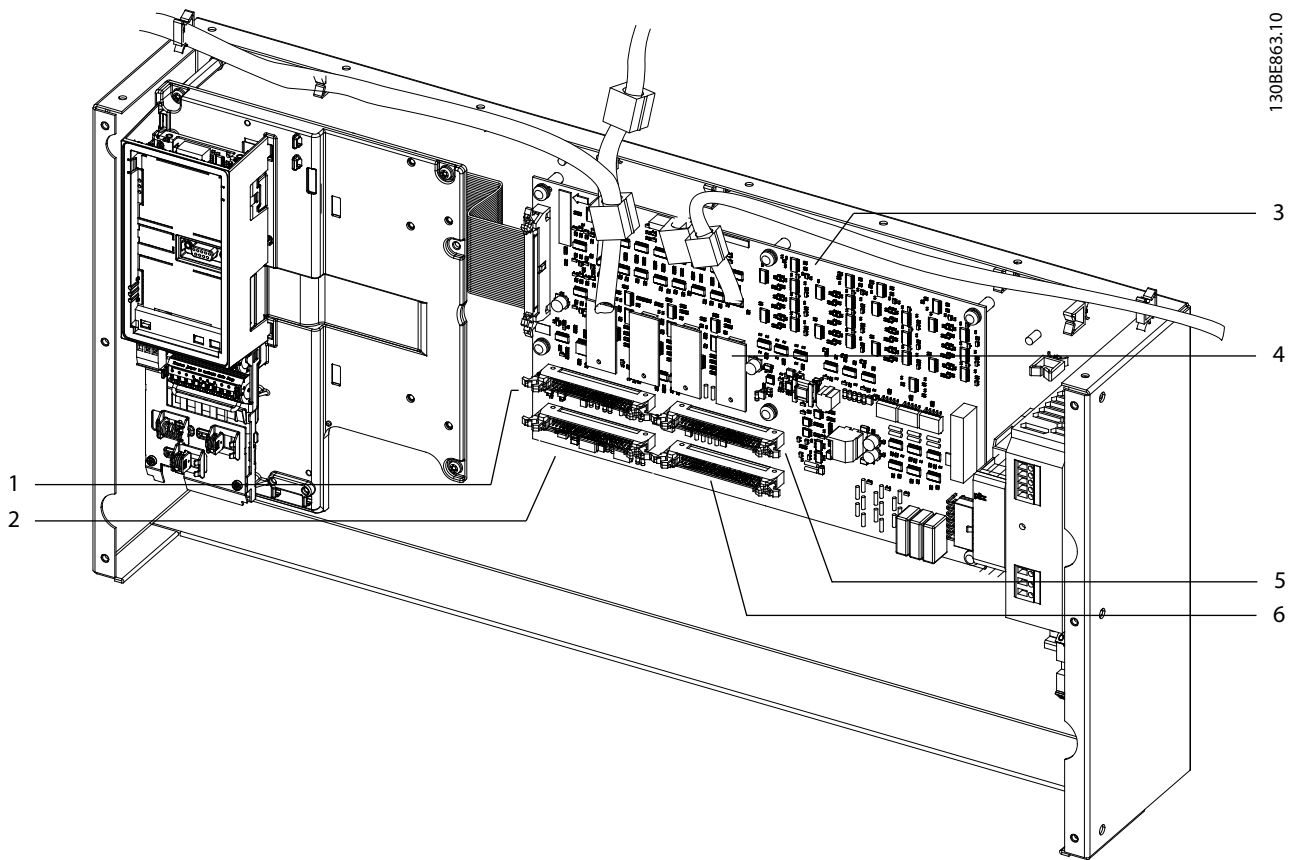

1	44-pin connector (MK111)	4	Scaling card (1 of 4)
2	44-pin connector (MK112)	5	44-pin connector (MK113)
3	MDCIC	6	44-pin connector (MK114)

Illustration 6.4 MDCIC Connectors

1. Remove the input power to all drive modules.
2. Wait 20 minutes for the capacitors to discharge completely. Use an appropriate voltage measuring device to make sure the capacitors are fully discharged.
3. Determine which drive module has failed. Refer to the report values in the alarm log, DC fuse failure status, or AC fuse failure status.
4. Disconnect the mains input, motor output, and DC busbars from the failed drive module.
5. On the control shelf, disconnect and remove the 44-pin ribbon cable leading from the failed drive module to the MDCIC.
6. On the control shelf, disconnect and remove the 44-pin ribbon cable leading from the failed drive module to the MDCIC.
7. Reconnect the 44-pin ribbon cables as shown in chapter 6.7.3 Wiring Configurations.
8. Reinstall the connecting hardware to link the remaining drive modules in parallel.
9. Reapply mains power to the input terminals.
10. The LCP initializes, displaying *warning 76, Power unit setup*.
11. Navigate to *parameter 14-59 Actual Number of Inverter Units* and enter the number of connected drive modules.
12. Remove mains power from the drive system's input terminals and wait until LCP display is off.
13. Reapply mains power to the input terminals.
14. The LCP restarts, displaying *warning 77, Reduced power mode*.

6.7.3 Wiring Configurations

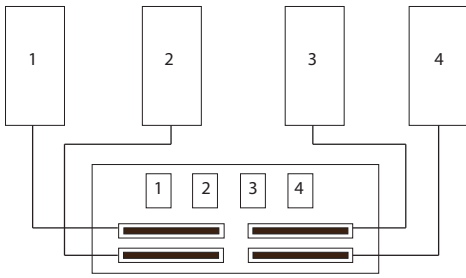

Illustration 6.5 Wiring Configuration of a 4-drive System

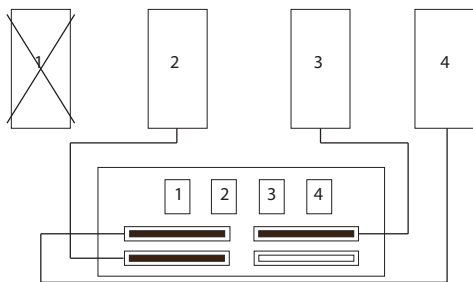

Illustration 6.6 Configuring 4-drive System with Failure of Drive Module 1

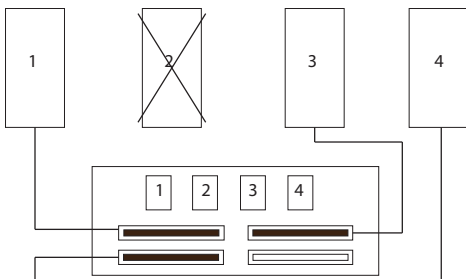

Illustration 6.7 Configuring 4-drive System with Failure of Drive Module 2

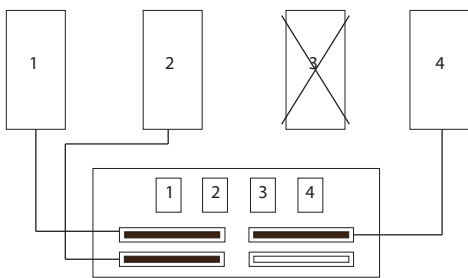
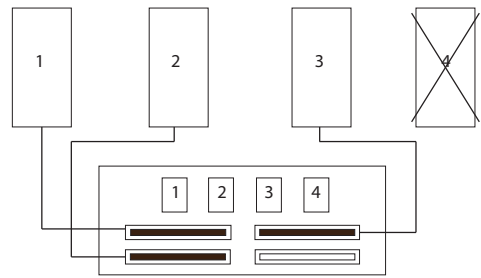

Illustration 6.8 Configuring 4-drive System with Failure of Drive Module 3

130BE864.10



130BE870.10

Illustration 6.9 Configuring 4-drive System with Failure of Drive Module 4

130BE866.10

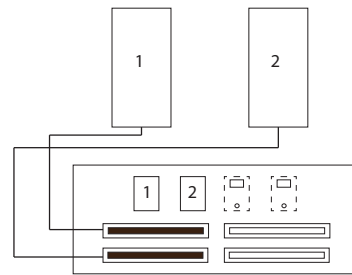

130BE868.10

Illustration 6.10 Wiring Configuration of a 2-drive System

130BE865.10

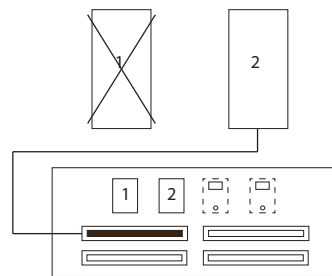

130BE869.10

Illustration 6.11 Configuring 2-drive System with Failure of Drive Module 1

130BE867.10

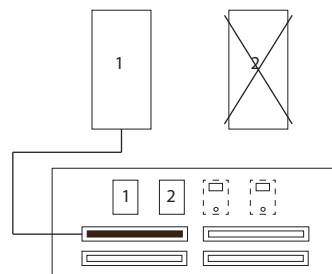

130BE871.10

Illustration 6.12 Configuring 2-drive System with Failure of Drive Module 2

7 Specifications

7.1 Power-dependent Specifications

7.1.1 VLT® HVAC Drive FC 102

Power range	N315	N355	N400	N450	N500
Drive modules	2	2	2	2	2
Rectifier configuration	12-pulse				6-pulse/12-pulse
High/normal load	NO	NO	NO	NO	NO
Typical shaft output at 400 V [kW]	315	355	400	450	500
Typical shaft output at 460 V [hp]	450	500	600	600	700/650
Protection rating	IP00				
Efficiency	0.98				
Output frequency [Hz]	0–590				
Heat sink overtemperature trip [°C (°F)]	110 (230)				
Power card ambient trip [°C (°F)]	80 (176)				
Output current [A]					
Continuous (at 380–440 V)	588	658	745	800	880
Intermittent (60 s overload) at 400 V	647	724	820	880	968
Continuous (at 460/500 V)	535	590	678	730	780
Intermittent (60 s overload) at 460/500 V	588	649	746	803	858
Continuous (at 400 V) [kVA]	407	456	516	554	610
Continuous (at 460 V) [kVA]	426	470	540	582	621
Continuous (at 500 V) [kVA]	463	511	587	632	675
Input current [A]					
Continuous (at 400 V)	567	647	733	787	875
Continuous (at 460/500 V)	516	580	667	718	759
Power losses [W]					
Drive modules at 400 V	5825	6110	7069	7538	8468
Drive modules at 460 V	4998	5964	6175	6609	7140
AC busbars at 400 V	550	555	561	565	575
AC busbars at 460 V	548	551	556	560	563
DC busbars during regeneration	93	95	98	101	105
Maximum cable size [mm² (mcm)]					
Mains ¹⁾	4x120 (250)				4x150 (300)
Motor	4x120 (250)				4x150 (300)
Brake	4x70 (2/0)			4x95 (3/0)	
Regeneration terminals	4x120 (250)		4x150 (300)	6x120 (250)	
Maximum external mains fuses					
6-pulse configuration	–	–	–	–	600 V, 1600 A
12-pulse configuration	700 A, 600 V				–

Table 7.1 FC 102, 380–480 V AC Mains Supply (2-module System)

1) For 12-pulse units, the cables between the star and delta terminals must be equal in number and length.

Power range	N560	N630	N710	N800	N1M0
Drive modules	4	4	4	4	4
Rectifier configuration	6-pulse/12-pulse				
High/normal load	NO	NO	NO	NO	NO
Typical shaft output at 400 V [kW]	560	630	710	800	1000
Typical shaft output at 460 V [hp]	750	900	1000	1200	1350
Protection rating	IP00				
Efficiency	0.98				
Output frequency [Hz]	0–590				
Heat sink overtemperature trip [°C (°F)]	110 (230)				
Power card ambient trip [°C (°F)]	80 (176)				
Output current [A]					
Continuous (at 380–440 V)	990	1120	1260	1460	1720
Intermittent (60 s overload) at 400 V	1089	1232	1386	1606	1892
Continuous (at 460/500 V)	890	1050	1160	1380	1530
Intermittent (60 s overload) at 460/500 V	979	1155	1276	1518	1683
Continuous (at 400 V) [kVA]	686	776	873	1012	1192
Continuous (at 460 V) [kVA]	709	837	924	1100	1219
Continuous (at 500 V) [kVA]	771	909	1005	1195	1325
Input current [A]					
Continuous (at 400 V)	964	1090	1227	1422	1675
Continuous (at 460/500 V)	867	1022	1129	1344	1490
Power losses [W]					
Drive modules at 400 V	8810	10199	11632	13253	16463
Drive modules at 460 V	7628	9324	10375	12391	13958
AC busbars at 400 V	665	680	695	722	762
AC busbars at 460 V	656	671	683	710	732
DC busbars during regeneration	218	232	250	276	318
Maximum cable size [mm² (mcm)]					
Mains ¹⁾	4x185 (350)	8x120 (250)			
Motor	4x185 (350)	8x120 (250)			
Brake	8x70 (2/0)			8x95 (3/0)	
Regeneration terminals	6x120 (250)	8x120 (250)		8x150 (300)	10x150 (300)
Maximum external mains fuses					
6-pulse configuration	600 V, 1600 A	600 V, 2000 A		600 V, 2500 A	
12-pulse configuration	600 V, 700 A	600 V, 900 A			600 V, 1500 A

Table 7.2 FC 102, 380–480 V AC Mains Supply (4-module System)

1) For 12-pulse units, the cables between the star and delta terminals must be equal in number and length.

Power range	N315	N400	N450	N500	N560	N630
Drive modules	2	2	2	2	2	2
Rectifier configuration	12-pulse					
High/normal load	NO	NO	NO	NO	NO	NO
Typical shaft output at 525–550 V [kW]	250	315	355	400	450	500
Typical shaft output at 575 V [hp]	350	400	450	500	600	650
Typical shaft output at 690 V [kW]	315	400	450	500	560	630
Protection rating	IP00					
Efficiency	0.98					
Output frequency [Hz]	0–590					
Heat sink overtemperature trip [°C (°F)]	110 (230)					
Power card ambient trip [°C (°F)]	80 (176)					
Output current [A]						
Continuous (at 550 V)	360	418	470	523	596	630
Intermittent (60 s overload) at 550 V	396	360	517	575	656	693
Continuous (at 575/690 V)	344	400	450	500	570	630
Intermittent (60 s overload) at 575/690 V	378	440	495	550	627	693
Continuous (at 550 V) kVA	343	398	448	498	568	600
Continuous (at 575 V) kVA	343	398	448	498	568	627
Continuous (at 690 V) kVA	411	478	538	598	681	753
Input current [A]						
Continuous (at 550 V)	355	408	453	504	574	607
Continuous (at 575 V)	339	490	434	482	549	607
Continuous (at 690 V)	352	400	434	482	549	607
Power losses [W]						
Drive modules at 575 V	4401	4789	5457	6076	6995	7431
Drive modules at 690 V	4352	4709	5354	5951	6831	7638
AC busbars at 575 V	540	541	544	546	550	553
DC busbars during regeneration	88	88.5	90	91	186	191
Maximum cable size [mm² (mcm)]						
Mains ¹⁾	2x120 (250)	4x120 (250)				
Motor	2x120 (250)	4x120 (250)				
Brake	4x70 (2/0)				4x95 (3/0)	
Regeneration terminals	4x120 (250)					
Maximum external mains fuses	700 V, 550 A			700 V, 630 A		

Table 7.3 FC 102, 525–690 V AC Mains Supply (2-module System)

1) For 12-pulse units, the cables between the star and delta terminals must be equal in number and length.

Power range	N710	N800	N900	N1M0	N1M2
Drive modules	4	4		4	4
Rectifier configuration	6-pulse/12-pulse				
High/normal load	NO	NO	NO	NO	NO
Typical shaft output at 525–550 V [kW]	560	670	750	850	1000
Typical shaft output at 575 V [hp]	750	950	1050	1150	1350
Typical shaft output at 690 V [kW]	710	800	900	1000	1200
Protection rating	IP00				
Efficiency	0.98				
Output frequency [Hz]	0–590				
Heat sink overtemperature trip [°C (°F)]	110 (230)				
Power card ambient trip [°C (°F)]	80 (176)				
Output current [A]					
Continuous (at 550 V)	763	889	988	1108	1317
Intermittent (60 s overload) at 550 V	839	978	1087	1219	1449
Continuous (at 575/690 V)	730	850	945	1060	1260
Intermittent (60 s overload) at 575/690 V	803	935	1040	1166	1590
Continuous (at 550 V)	727	847	941	1056	1056
Continuous (at 575 V)	727	847	941	1056	1056
Continuous (at 690 V)	872	1016	1129	1267	1506
Input current [A]					
Continuous (at 550 V)	743	866	962	1079	1282
Continuous (at 575 V)	711	828	920	1032	1227
Continuous (at 690 V)	711	828	920	1032	1227
Power losses [W]					
Drive modules at 575 V	8683	10166	11406	12852	15762
Drive modules at 690 V	8559	9996	11188	12580	15358
AC busbars at 575 V	644	653	661	672	695
DC busbars during regeneration	198	208	218	231	256
Maximum cable size [mm² (mcm)]					
Mains ¹⁾	4x120 (250)	6x120 (250)			8x120 (250)
Motor	4x120 (250)	6x120 (250)			8x120 (250)
Brake	8x70 (2/0)			8x95 (3/0)	
Regeneration terminals	4x150 (300)	6x120 (250)		6x150 (300)	8x120 (250)
Maximum external mains fuses					
6-pulse configuration	700 V, 1600 A				700 V, 2000 A
12-pulse configuration	700 V, 900 A			700 V, 1500 A	

7
Table 7.4 FC 102, 525–690 V AC Mains Supply (4-module System)

1) For 12-pulse units, the cables between the star and delta terminals must be equal in number and length.

7.1.2 VLT® AQUA Drive FC 202

Power range	N315		N355		N400		N450		N500		
Drive modules	2		2		2		2		2		
Rectifier configuration	12-pulse								6-pulse/12-pulse		
High/normal load	HO	NO	HO	NO	HO	NO	HO	NO	HO	NO	
Typical shaft output at 400 V [kW]	250	315	315	355	355	400	400	450	450	500	
Typical shaft output at 460 V [hp]	350	450	450	500	500	600	550	600	600	650	
Protection rating	IP00										
Efficiency	0.98										
Output frequency [Hz]	0–590										
Heat sink overtemperature trip [°C (°F)]	110 (230)										
Power card ambient trip [°C (°F)]	80 (176)										
Output current [A]											
Continuous (at 400 V)	480	588	600	658	658	745	695	800	810	880	
Intermittent (60 s overload) at 400 V	720	647	900	724	987	820	1043	880	1215	968	
Continuous (at 460/500 V)	443	535	540	590	590	678	678	730	730	780	
Intermittent (60 s overload) at 460/500 V	665	588	810	649	885	746	1017	803	1095	858	
Continuous (at 400 V) [kVA]	333	407	416	456	456	516	482	554	554	610	
Continuous (at 460 V) [kVA]	353	426	430	470	470	540	540	582	582	621	
Continuous (at 500 V) [kVA]	384	463	468	511	511	587	587	632	632	675	
Input current [A]											
Continuous (at 400 V)	463	567	590	647	647	733	684	787	779	857	
Continuous (at 460/500 V)	427	516	531	580	580	667	667	718	711	759	
Power losses [W]											
Drive modules at 400 V	4505	5825	5502	6110	6110	7069	6375	7538	7526	8468	
Drive modules at 460 V	4063	4998	5384	5964	5271	6175	6070	6609	6604	7140	
AC busbars at 400 V	545	550	551	555	555	561	557	565	566	575	
AC busbars at 460 V	543	548	548	551	551	556	556	560	560	563	
DC busbars during regeneration	93	93	95	95	98	98	101	101	105	105	
Maximum cable size [mm² (mcm)]											
Mains ¹⁾	4x120 (250)								4x150 (300)		
Motor	4x120 (250)								4x150 (300)		
Brake	4x70 (2/0)						4x95 (3/0)				
Regeneration terminals	4x120 (250)				6x120 (250)			6x120 (250)			
Maximum external mains fuses											
6-pulse configuration	–		–		–		–		600 V, 1600 A		
12-pulse configuration	600 V, 700 A								600 V, 900 A		

Table 7.5 FC 202, 380–480 V AC Mains Supply (2-module System)

1) For 12-pulse units, the cables between the star and delta terminals must be equal in number and length.

Power range	N560		N630		N710		N800		N1M0	
Drive modules	4		4		4		4		4	
Rectifier configuration	6-pulse/12-pulse									
High/normal load	HO	NO	HO	NO	HO	NO	HO	NO	HO	NO
Typical shaft output at 400 V [kW]	500	560	560	630	630	710	710	800	800	1000
Typical shaft output at 460 V [hp]	650	750	750	900	900	1000	1000	1200	1200	1350
Protection rating	IP00									
Efficiency	0.98									
Output frequency [Hz]	0–590									
Heat sink overtemperature trip [°C (°F)]	110 (230)									
Power card ambient trip [°C (°F)]	80 (176)									
Output current [A]										
Continuous (at 400 V)	880	990	990	1120	1120	1260	1260	1460	1460	1720
Intermittent (60 s overload) at 400 V	1320	1089	1485	1232	1680	1386	1890	1606	2190	1892
Continuous (at 460/500 V)	780	890	890	1050	1050	1160	1160	1380	1380	1530
Intermittent (60 s overload) at 460/500 V	1170	979	1335	1155	1575	1276	1740	1518	2070	1683
Continuous (at 400 V) [kVA]	610	686	686	776	776	873	873	1012	1012	1192
Continuous (at 460 V) [kVA]	621	709	709	837	837	924	924	1100	1100	1219
Continuous (at 500 V) [kVA]	675	771	771	909	909	1005	1005	1195	1195	1325
Input current [A]										
Continuous (at 400 V)	857	964	964	1090	1090	1227	1127	1422	1422	1675
Continuous (at 460 V)	759	867	867	1022	1022	1129	1129	1344	1344	1490
Power losses [W]										
Drive modules at 400 V	7713	8810	8918	10199	10181	11632	11390	13253	13479	16463
Drive modules at 460 V	6641	7628	7855	9324	9316	10375	12391	12391	12376	13958
AC busbars at 400 V	655	665	665	680	680	695	695	722	722	762
AC busbars at 460 V	647	656	656	671	671	683	683	710	710	732
DC busbars during regeneration	218	218	232	232	250	250	276	276	318	318
Maximum cable size [mm² (mcm)]										
Mains ¹⁾	4x185 (350)			8x125 (250)						
Motor	4x185 (350)			8x125 (250)						
Brake	8x70 (2/0)						8x95 (3/0)			
Regeneration terminals	6x125 (250)		8x125 (250)				8x150 (300)		10x150 (300)	
Maximum external mains fuses										
6-pulse configuration	600 V, 1600 A		600 V, 2000 A				600 V, 2500 A			
12-pulse configuration	600 V, 900 A				600 V, 1500 A					

Table 7.6 FC 202, 380–480 V AC Mains Supply (4-module System)

1) For 12-pulse units, the cables between the star and delta terminals must be equal in number and length.

Power range	N315		N400		N450	
Drive modules	2		2		2	
Rectifier configuration	12-pulse					
High/normal load	HO	NO	HO	NO	HO	NO
Typical shaft output at 525–550 V [kW]	200	250	250	315	315	355
Typical shaft output at 575 V [hp]	300	350	350	400	400	450
Typical shaft output at 690 V [kW]	250	315	315	400	355	450
Protection rating	IP00					
Efficiency	0.98					
Output frequency [Hz]	0–590					
Heat sink overtemperature trip [°C (°F)]	110 (230)					
Power card ambient trip [°C (°F)]	80 (176)					
Output current [A]						
Continuous (at 550 V)	303	360	360	418	395	470
Intermittent (60 s overload) at 550 V	455	396	560	460	593	517
Continuous (at 575/690 V)	290	344	344	400	380	450
Intermittent (60 s overload) at 575/690 V	435	378	516	440	570	495
Continuous (at 550 V)	289	343	343	398	376	448
Continuous (at 575 V)	289	343	343	398	378	448
Continuous (at 690 V)	347	411	411	478	454	538
Input current [A]						
Continuous (at 550 V)	299	355	355	408	381	453
Continuous (at 575 V)	286	339	339	490	366	434
Continuous (at 690 V)	296	352	352	400	366	434
Power losses [W]						
Drive modules at 575 V	3688	4401	4081	4789	4502	5457
Drive modules at 690 V	3669	4352	4020	4709	4447	5354
AC busbars at 575 V	538	540	540	541	540	544
DC busbars during regeneration	88	88	89	89	90	90
Maximum cable size [mm² (mcm)]						
Mains ¹⁾	2x120 (250)		4x120 (250)			
Motor	2x120 (250)		4x120 (250)			
Brake	4x70 (2/0)					
Regeneration terminals	4x120 (250)					
Maximum external mains fuses	700 V, 550 A					

Table 7.7 FC 202, 525–690 V AC Mains Supply (2-module System)

1) For 12-pulse units, the cables between the star and delta terminals must be equal in number and length.

Power range	N500		N560		N630	
Drive modules	2		2		2	
Rectifier configuration	12-pulse					
High/normal load	HO	NO	HO	NO	HO	NO
Typical shaft output at 525–550 V [kW]	315	400	400	450	450	500
Typical shaft output at 575 V [hp]	400	500	500	600	600	650
Typical shaft output at 690 V [kW]	400	500	500	560	560	630
Protection rating	IP00					
Efficiency	0.98					
Output frequency [Hz]	0–590					
Heat sink overtemperature trip [°C (°F)]	110 (230)					
Power card ambient trip [°C (°F)]	80 (176)					
Output current [A]						
Continuous (at 550 V)	429	523	523	596	596	630
Intermittent (60 s overload) at 550 V	644	575	785	656	894	693
Continuous (at 575/690 V)	410	500	500	570	570	630
Intermittent (60 s overload) at 575/690 V	615	550	750	627	627	693
Continuous (at 550 V) [kVA]	409	498	498	568	568	600
Continuous (at 575 V) [kVA]	408	498	598	568	568	627
Continuous (at 690 V) [kVA]	490	598	598	681	681	753
Input current [A]						
Continuous (at 550 V)	413	504	504	574	574	607
Continuous (at 575 V)	395	482	482	549	549	607
Continuous (at 690 V)	395	482	482	549	549	607
Power losses [W]						
Drive modules at 575 V	4892	6076	6016	6995	6941	7431
Drive modules at 690 V	4797	5951	5886	6831	6766	7638
AC busbars at 575 V	542	546	546	550	550	553
DC busbars during regeneration	91	91	186	186	191	191
Maximum cable size [mm² (mcm)]						
Mains ¹⁾	4x120 (250)					
Motor	4x120 (250)					
Brake	4x70 (2/0)		4x95 (3/0)			
Regeneration terminals	4x120 (250)					
Maximum external mains fuses	700 V, 630 A					

7

Table 7.8 FC 202, 525–690 V AC Mains Supply (2-module System)

1) For 12-pulse units, the cables between the star and delta terminals must be equal in number and length.

Power range	N710		N800		N900		N1M0		N1M2	
Drive modules	4		4		4		4		4	
Rectifier configuration	6-pulse/12-pulse									
High/normal load	HO	NO	HO	NO	HO	NO	HO	NO	HO	NO
Typical shaft output at 525–550 V [kW]	500	560	560	670	670	750	750	850	850	1000
Typical shaft output at 575 V [hp]	650	750	750	950	950	1050	1050	1150	1150	1350
Typical shaft output at 690 V [kW]	630	710	710	800	800	900	900	1000	1000	1200
Protection rating	IP00									
Efficiency	0.98									
Output frequency [Hz]	0–590									
Heat sink overtemperature trip [°C (°F)]	110 (230)									
Power card ambient trip [°C (°F)]	80 (176)									
Output current [A]										
Continuous (at 550 V)	659	763	763	889	889	988	988	1108	1108	1317
Intermittent (60 s overload) at 550 V	989	839	1145	978	1334	1087	1482	1219	1662	1449
Continuous (at 575/690 V)	630	730	730	850	850	945	945	1060	1060	1260
Intermittent (60 s overload) at 575/690 V	945	803	1095	935	1275	1040	1418	1166	1590	1590
Continuous (at 550 V) [kVA]	628	727	727	847	847	941	941	1056	1056	1255
Continuous (at 575 V) [kVA]	627	727	727	847	847	941	941	1056	1056	1255
Continuous (at 690 V) [kVA]	753	872	872	1016	1016	1129	1129	1267	1267	1506
Input current [A]										
Continuous (at 550 V)	642	743	743	866	866	962	1079	1079	1079	1282
Continuous (at 575 V)	613	711	711	828	828	920	1032	1032	1032	1227
Continuous (at 690 V)	613	711	711	828	828	920	1032	1032	1032	1227
Power losses [W]										
Drive modules at 575 V	7469	8683	8668	10166	10163	11406	11292	12852	12835	15762
Drive modules at 690 V	7381	8559	8555	9996	9987	11188	11077	12580	12551	15358
AC busbars at 575 V	637	644	644	653	653	661	661	672	672	695
DC busbars during regeneration	198	198	208	208	218	218	231	231	256	256
Maximum cable size [mm² (mcm)]										
Mains ¹⁾	4x120 (250)		6x120 (250)					8x120 (250)		
Motor	4x120 (250)		6x120 (250)					8x120 (250)		
Brake	8x70 (2/0)						8x95 (3/0)			
Regeneration terminals	4x150 (300)		6x120 (250)				6x150 (300)		8x120 (250)	
Maximum external mains fuses										
6-pulse configuration	700 V, 1600 A								700 V, 2000 A	
12-pulse configuration	700 V, 900 A						700 V, 1500 A			

Table 7.9 FC 202, 525–690 V AC Mains Supply (4-module System)

1) For 12-pulse units, the cables between the star and delta terminals must be equal in number and length.

7.1.3 VLT® AutomationDrive FC 302

Power range	N250		N315		N355		N400		N450		
Drive modules	2		2		2		2		2		
Rectifier configuration	12-pulse								6-pulse/12-pulse		
High/normal load	HO	NO	HO	NO	HO	NO	HO	NO	HO	NO	
Typical shaft output at 400 V [kW]	250	315	315	355	355	400	400	450	450	500	
Typical shaft output at 460 V [hp]	350	450	450	500	500	600	550	600	600	650	
Typical shaft output at 500 V [kW]	315	355	355	400	400	500	500	530	530	560	
Protection rating	IP00										
Efficiency	0.98										
Output frequency [Hz]	0–590										
Heat sink overtemperature trip [°C (°F)]	110 (230)										
Power card ambient trip [°C (°F)]	80 (176)										
Output current [A]											
Continuous (at 380–440 V)	480	588	600	658	658	745	695	800	810	880	
Intermittent (60 s overload) at 400 V	720	647	900	724	987	820	1043	880	1215	968	
Continuous (at 460/500 V)	443	535	540	590	590	678	678	730	730	780	
Intermittent (60 s overload) at 460/500 V	665	588	810	649	885	746	1017	803	1095	858	
Continuous (at 400 V) [kVA]	333	407	416	456	456	516	482	554	554	610	
Continuous (at 460 V) [kVA]	353	426	430	470	470	540	540	582	582	621	
Continuous (at 500 V) [kVA]	384	463	468	511	511	587	587	632	632	675	
Input current [A]											
Continuous (at 400 V)	463	567	590	647	647	733	684	787	779	857	
Continuous (at 460/500 V)	427	516	531	580	580	667	667	718	711	759	
Power losses [W]											
Drive modules at 400 V	4505	5825	5502	6110	6110	7069	6375	7538	7526	8468	
Drive modules at 460 V	4063	4998	5384	5964	5721	6175	6070	6609	6604	7140	
AC busbars at 400 V	545	550	551	555	555	561	557	565	566	575	
AC busbars at 460 V	543	548	548	551	556	556	556	560	560	563	
Maximum cable size [mm² (mcm)]											
Mains ¹⁾	4x120 (250)								4x150 (300)		
Motor	4x120 (250)								4x150 (300)		
Brake	4x70 (2/0)								4x95 (3/0)		
Regeneration terminals	4x120 (250)				4x150 (300)			6x120 (250)			
Maximum external mains fuses											
6-pulse configuration	–		–		–		–		600 V, 1600 A		
12-pulse configuration	600 V, 700 A								600 V, 900 A		

Table 7.10 FC 302, 380–500 V AC Mains Supply (2-module System)

1) For 12-pulse units, the cables between the star and delta terminals must be equal in number and length.

Power range	N500		N560		N630		N710		N800	
Drive modules	4		4		4		4		4	
Rectifier configuration	6-pulse/12-pulse									
High/normal load	HO	NO	HO	NO	HO	NO	HO	NO	HO	NO
Typical shaft output at 400 V [kW]	500	560	560	630	630	710	710	800	800	1000
Typical shaft output at 460 V [hp]	650	750	750	900	900	1000	1000	1200	1200	1350
Typical shaft output at 500 V [kW]	560	630	630	710	710	800	800	1000	1000	1100
Protection rating	IP00									
Efficiency	0.98									
Output frequency [Hz]	0–590									
Heat sink overtemperature trip [°C (°F)]	110 (230)									
Power card ambient trip [°C (°F)]	80 (176)									
Output current [A]										
Continuous (at 380–440 V)	880	990	990	1120	1120	1260	1260	1460	1460	1720
Intermittent (60 s overload) at 400 V	1320	1089	1485	1232	1680	1386	1890	1606	2190	1892
Continuous (at 460/500 V)	780	890	890	1050	1050	1160	1160	1380	1380	1530
Intermittent (60 s overload) at 460/500 V	1170	979	1335	1155	1575	1276	1740	1518	2070	1683
Continuous (at 400 V) [kVA]	610	686	686	776	776	873	873	1012	1012	1192
Continuous (at 460 V) [kVA]	621	709	709	837	837	924	924	1100	1100	1219
Continuous (at 500 V) [kVA]	675	771	771	909	909	1005	1005	1195	1195	1325
Input current [A]										
Continuous (at 400 V)	857	964	964	1090	1090	1227	1227	1422	1422	1675
Continuous (at 460/500 V)	759	867	867	1022	1022	1129	1129	1344	1344	1490
Power losses [W]										
Drive modules at 400 V	7713	8810	8918	10199	10181	11632	11390	13253	13479	16463
Drive modules at 460 V	6641	7628	7855	9324	9316	10375	12391	12391	12376	13958
AC busbars at 400 V	655	665	665	680	680	695	695	722	722	762
AC busbars at 460 V	647	656	656	671	671	683	683	710	710	732
DC busbars during regeneration	218	218	232	232	250	276	276	276	318	318
Maximum cable size [mm² (mcm)]										
Mains ¹⁾	4x185 (350)			8x120 (250)						
Motor	4x185 (350)			8x120 (250)						
Brake	8x70 (2/0)						8x95 (3/0)			
Regeneration terminals	6x125 (250)			8x125 (250)			8x150 (300)		10x150 (300)	
Maximum external mains fuses										
6-pulse configuration	600 V, 1600 A			600 V, 2000 A			600 V, 2500 A			
12-pulse configuration	600 V, 900 A				600 V, 1500 A					

Table 7.11 FC 302, 380–500 V AC Mains Supply (4-module System)

1) For 12-pulse units, the cables between the star and delta terminals must be equal in number and length.

Power range	N250		N315		N355		N400	
Drive modules	2		2		2		2	
Rectifier configuration	12-pulse							
High/normal load	HO	NO	HO	NO	HO	NO	HO	NO
Typical shaft output at 525–550 V [kW]	200	250	250	315	315	355	315	400
Typical shaft output at 575 V [hp]	300	350	350	400	400	450	400	500
Typical shaft output at 690 V [kW]	250	315	315	400	355	450	400	500
Protection rating	IP00							
Efficiency	0.98							
Output frequency [Hz]	0–590							
Heat sink overtemperature trip [°C (°F)]	110 (230)							
Power card ambient trip [°C (°F)]	80 (176)							
Output current [A]								
Continuous (at 550 V)	303	360	360	418	395	470	429	523
Intermittent (60 s overload) at 550 V	455	396	560	360	593	517	644	575
Continuous (at 575/690 V)	290	344	344	400	380	450	410	500
Intermittent (60 s overload) at 575/690 V	435	378	516	440	570	495	615	550
Continuous (at 550 V) [kVA]	289	343	343	398	376	448	409	498
Continuous (at 575 V) [kVA]	289	343	343	398	378	448	408	498
Continuous (at 690 V) [kVA]	347	411	411	478	454	538	490	598
Input current [A]								
Continuous (at 550 V)	299	355	355	408	381	453	413	504
Continuous (at 575 V)	286	339	339	490	366	434	395	482
Continuous (at 690 V)	296	352	352	400	366	434	395	482
Power losses [W]								
Drive modules at 600 V	3688	4401	4081	4789	4502	5457	4892	6076
Drive modules at 690 V	3669	4352	4020	4709	4447	5354	4797	5951
AC busbars at 575 V	538	540	540	541	540	544	542	546
DC busbars during regeneration	88	88	89	89	90	90	91	91
Maximum cable size [mm² (mcm)]								
Mains ¹⁾	2x120 (250)			4x120 (250)				
Motor	2x120 (250)			4x120 (250)				
Brake	4x70 (2/0)							
Regeneration terminals	4x120 (250)							
Maximum external mains fuses	700 V, 550 A							

7
Table 7.12 FC 302, 525–690 V AC Mains Supply (2-module System)
1) For 12-pulse units, the cables between the star and delta terminals must be equal in number and length.

Power range	N500		N560	
Drive modules	2		2	
Rectifier configuration	12-pulse			
High/normal load	HO	NO	HO	NO
Typical shaft output at 525–550 V [kW]	400	450	450	500
Typical shaft output at 575 V [hp]	500	600	600	650
Typical shaft output at 690 V [kW]	500	560	560	630
Protection rating	IP00			
Efficiency	0.98			
Output frequency [Hz]	0–590			
Heat sink overtemperature trip [°C (°F)]	110 (230)			
Power card ambient trip [°C (°F)]	80 (176)			
Output current [A]				
Continuous (at 550 V)	523	596	596	630
Intermittent (60 s overload) at 550 V	785	656	894	693
Continuous (at 575/690 V)	500	570	570	630
Intermittent (60 s overload) at 575/690 V	750	627	627	693
Continuous (at 550 V) [kVA]	498	568	568	600
Continuous (at 575 V) [kVA]	498	568	568	627
Continuous (at 690 V) [kVA]	598	681	681	753
Input current [A]				
Continuous (at 550 V)	504	574	574	607
Continuous (at 575 V)	482	549	549	607
Continuous (at 690 V)	482	549	549	607
Power losses [W]				
Drive modules at 600 V	6016	6995	6941	7431
Drive modules at 690 V	5886	6831	6766	7638
AC busbars at 575 V	546	550	550	553
DC busbars during regeneration	186	186	191	191
Maximum cable size [mm² (mcm)]				
Mains ¹⁾	4x120 (250)			
Motor	4x120 (250)			
Brake	4x95 (3/0)			
Regeneration terminals	4x120 (250)			
Maximum external mains fuses	700 V, 630 A			

Table 7.13 FC 302, 525–690 V AC Mains Supply (2-module System)

1) For 12-pulse units, the cables between the star and delta terminals must be equal in number and length.

Power range	N630		N710		N800		N900		N1M0	
Drive modules	4		4		4		4		4	
Rectifier configuration	6-pulse/12-pulse									
High/normal load	HO	NO	HO	NO	HO	NO	HO	NO	HO	NO
Typical shaft output at 525–550 V [kW]	500	560	560	670	670	750	750	850	850	1000
Typical shaft output at 575 V [hp]	650	750	750	950	950	1050	1050	1150	1150	1350
Typical shaft output at 690 V [kW]	630	710	710	800	800	900	900	1000	1000	1200
Protection rating	IP00									
Efficiency	0.98									
Output frequency [Hz]	0–590									
Heat sink overtemperature trip [°C (°F)]	110 (230)									
Power card ambient trip [°C (°F)]	80 (176)									
Output current [A]										
Continuous (at 550 V)	659	763	763	889	889	988	988	1108	1108	1317
Intermittent (60 s overload) at 550 V	989	839	1145	978	1334	1087	1482	1219	1662	1449
Continuous (at 575/690 V)	630	730	730	850	850	945	945	1060	1060	1260
Intermittent (60 s overload) at 575/690 V	945	803	1095	935	1275	1040	1418	1166	1590	1590
Continuous (at 550 V) [kVA]	628	727	727	847	847	941	941	1056	1056	1255
Continuous (at 575 V) [kVA]	627	727	727	847	847	941	941	1056	1056	1255
Continuous (at 690 V) [kVA]	753	872	872	1016	1016	1129	1129	1267	1267	1506
Input current [A]										
Continuous (at 550 V)	642	743	743	866	866	962	1079	1079	1079	1282
Continuous (at 575 V)	613	711	711	828	828	920	1032	1032	1032	1227
Continuous (at 690 V)	613	711	711	828	828	920	1032	1032	1032	1227
Power losses [W]										
Drive modules at 600 V	7469	8683	8668	10166	10163	11406	11292	12852	12835	15762
Drive modules at 690 V	7381	8559	8555	9996	9987	11188	11077	12580	12551	15358
AC busbars at 575 V	637	644	644	653	653	661	661	672	672	695
DC busbars during regeneration	198	198	208	208	218	218	231	231	256	256
Maximum cable size [mm² (mcm)]										
Mains ¹⁾	4x120 (250)		6x120 (250)				8x120 (250)			
Motor	4x120 (250)		6x120 (250)				8x120 (250)			
Brake	8x70 (2/0)						8x95 (3/0)			
Regeneration terminals	4x150 (300)		6x120 (250)				6x150 (300)		8x120 (250)	
Maximum external mains fuses										
6-pulse configuration	700 V, 1600 A								700 V, 2000 A	
12-pulse configuration	700 V, 900 A						700 V, 1500 A			

7
Table 7.14 FC 302, 525–690 V AC Mains Supply (4-module System)

1) For 12-pulse units, the cables between the star and delta terminals must be equal in number and length.

7.2 Connection Tightening Torques

When tightening electrical connections, it is important to tighten with the correct torque. Using too little or too much torque results in a bad electrical connection. Always use a torque wrench to ensure that the bolts are correctly torqued.

	Mains	Motor	Regen	Load sharing	Ground	Brake
Bolt size	M10	M10	M10	M10	M8	M8
Torque [Nm (in-lbs)]	19–40 (168–354)	19–40 (168–354)	19–40 (168–354)	19–40 (168–354)	8.5–20.5 (75–181)	8.5–20.5 (75–181)

Table 7.15 Tightening of Terminals

7.3 Fuses and Circuit Breakers

Use recommended AC fuses or circuit breakers (or both) as protection against component breakdown inside the drive system (first fault). DC fuses are provided with the VLT® Parallel Drive Modules basic kit.

NOTICE

The use of fuses on the supply side is mandatory for IEC 60364 (CE) compliant installations.

The use of recommended fuses and circuit breakers ensures that possible damage to the drive system is limited to damage inside the unit. With the proper fusing, the drive system's short circuit current rating (SCCR) is 100000 A_{rms} (symmetrical).

7.3.1 Protection

⚠ WARNING

Overheated cables are a fire hazard. Failure to use overload protection when installing cables can result in equipment damage.

Branch circuit protection

To protect the installation against electrical and fire hazards, all branch circuits in an installation, switch gear, and machines must be protected against short circuits and overcurrent according to national or international regulations.

Short-circuit protection

Avoid electrical or fire hazards by protecting the drive system against short circuits. To protect service personnel and equipment against an internal failure in the unit, Danfoss recommends using the fuses described in *chapter 7.3.2 Fuse Selection*. The drive system provides full short-circuit protection against a short circuit on the motor output.

Overcurrent protection

To avoid fire hazards due to overheating of cables in the installation, use overload protection. The drive system is equipped with an internal overcurrent protection that can be used for upstream overload protection. See *parameter 4-18 Current Limit*. Moreover, fuses or circuit breakers can be used to provide the overcurrent protection in the installation. Overcurrent protection must always be carried out according to national regulations.

7.3.2 Fuse Selection

Recommended AC fuses are listed in *chapter 7.3.2.1 Recommended Fuses for CE Compliance* and *chapter 7.3.2.2 Recommended Fuses for UL Compliance*.

NOTICE

Danfoss recommends using the appropriate AC fuses to ensure CE and UL compliance. If a malfunction occurs, not following these recommendations can result in unnecessary damage to the drive system.

7.3.2.1 Recommended Fuses for CE Compliance

Drive modules in system	FC 302 modules [kW]	FC 102 and FC 202 modules [kW]	Recommended fuse	Recommended fuse (maximum)
2	N250	N315	aR-630	aR-630
2	N315	N355	aR-630	aR-630
2	N355	N400	aR-630	aR-630
2	N400	N450	aR-800	aR-800
2	N450	N500	aR-800	aR-800
4	N500	N560	aR-900	aR-900
4	N560	N630	aR-900	aR-900
4	N630	N710	aR-1600	aR-1600
4	N710	N800	aR-1600	aR-1600
4	N800	N1M0	aR-1600	aR-1600

Table 7.16 12-Pulse Drive Systems (380–500 V AC)

Drive modules in system	FC 302 modules [kW]	FC 102 and FC 202 modules [kW]	Recommended fuse	Recommended fuse (maximum)
2	N450	N500	aR-1600	aR-1600
4	N500	N560	aR-2500	aR-2500
4	N560	N630	aR-2500	aR-2500
4	N630	N710	aR-2500	aR-2500
4	N710	N800	aR-2500	aR-2500
4	N800	N1M0	aR-2500	aR-2500

Table 7.17 6-Pulse Drive Systems (380–500 V AC)

Drive modules in system	FC 302 modules [kW]	FC 102 and FC 202 modules [kW]	Recommended fuse	Recommended fuse (maximum)
2	N250	N315	aR-550	aR-550
2	N315	N355	aR-630	aR-630
2	N355	N400	aR-630	aR-630
2	N400	N500	aR-630	aR-630
2	N500	N560	aR-630	aR-630
2	N560	N630	aR-900	aR-900
4	N630	N710	aR-900	aR-900
4	N710	N800	aR-900	aR-900
4	N800	N900	aR-900	aR-900
4	N900	N1M0	aR-1600	aR-1600
4	N1M0	N1M2	aR-1600	aR-1600

Table 7.18 12-Pulse Drive Systems (525–690 V AC)

Drive modules in system	FC 302 modules [kW]	FC 102 and FC 202 modules [kW]	Recommended fuse	Recommended fuse (maximum)
4	N630	N710	aR-1600	aR-1600
4	N710	N800	aR-2000	aR-2000
4	N800	N900	aR-2500	aR-2500
4	N900	N1M0	aR-2500	aR-2500
4	N1M0	N1M2	aR-2500	aR-2500

Table 7.19 6-Pulse Drive Systems (525–690 V AC)



7.3.2.2 Recommended Fuses for UL Compliance

- The drive modules are supplied with built-in AC fuses. The modules have been qualified for 100 kA short circuit current rating (SCCR) for the standard busbar configurations at all voltages (380–690 V AC).
- The drive system is qualified for 100 kA SCCR with any Class L or Class T UL-listed fuses connected at the input terminals of the drive modules, if no power options or extra busbars are connected externally.
- The current rating of the Class L or Class T fuses should not exceed the listed fuse rating in *Table 7.20* to *Table 7.23*.

Drive modules in system	FC 302 modules [kW]	FC 102 and FC 202 modules [kW]	Recommended fuse (maximum)
2	N250	N315	aR-630
2	N315	N355	aR-630
2	N355	N400	aR-630
2	N400	N450	aR-800
2	N450	N500	aR-800
4	N500	N560	aR-900
4	N560	N630	aR-900
4	N630	N710	aR-1600
4	N710	N800	aR-1600
4	N800	N1M0	aR-1600

Table 7.20 12-Pulse Drive Systems (380–500 V AC)

Any minimum 500 V UL-listed fuse can be used for the 380–500 V AC drive systems.

Drive modules in system	FC 302 modules [kW]	FC 102 and FC 202 modules [kW]	Recommended fuse (maximum)
2	N450	N500	aR-1600
4	N500	N560	aR-2500
4	N560	N630	aR-2500
4	N630	N710	aR-2500
4	N710	N800	aR-2500
4	N800	N1M0	aR-2500

Table 7.21 6-Pulse Drive Systems (380–500 V AC)

Any minimum 500 V UL-listed fuse can be used for the 380–500 V AC drive systems.

Drive modules in system	FC 302 modules [kW]	FC 102 and FC 202 modules [kW]	Recommended fuse (maximum)
2	N250	N315	aR-550
2	N315	N355	aR-630
2	N355	N400	aR-630
2	N400	N500	aR-630
2	N500	N560	aR-630
2	N560	N630	aR-900
4	N630	N710	aR-900
4	N710	N800	aR-900
4	N800	N900	aR-900
4	N900	N1M0	aR-1600
4	N1M0	N1M2	aR-1600

Table 7.22 12-Pulse Drive Systems (525–690 V AC)

Any minimum 700 V UL-listed fuse can be used for the 525–690 V AC drive systems.

Drive modules in system	FC 302 modules [kW]	FC 102 and FC 202 modules [kW]	Recommended fuse (maximum)
4	N630	N710	aR-1600
4	N710	N800	aR-2000
4	N800	N900	aR-2500
4	N900	N1M0	aR-2500
4	N1M0	N1M2	aR-2500

Table 7.23 6-Pulse Drive Systems (525–690 V AC)

Any minimum 700 V UL-listed fuse can be used for the 525–690 V AC drive systems.

7.3.3 Fuse Replacement

If it becomes necessary to replace an AC or DC fuse, refer to the *VLT® FC Series, D-frame Service Manual* and the *VLT® Parallel Drive Modules DC Fuses Installation Instructions*.

7.3.4 Short Circuit Current Rating (SCCR)

The drive modules are supplied with built-in AC fuses. The modules have been qualified for 100 kA short circuit current rating (SCCR) for the standard busbar configurations at all voltages (380–690 V AC). For more information on short-circuit protection of the drive modules, see *chapter 7.3.1 Protection*. For more information on the recommended fuses for CE or UL compliance, see *chapter 7.3.2.1 Recommended Fuses for CE Compliance* or *chapter 7.3.2.2 Recommended Fuses for UL Compliance*, respectively.

8 Appendix

8.1 Symbols, Abbreviations, and Conventions

°C	Degrees Celsius
°F	Degrees Fahrenheit
Ω	Ohm
A_{rms}	Amperes root-mean-square
AC	Alternating current
AEO	Automatic energy optimization
AIC	Active in-feed converter
AMA	Automatic motor adaptation
CD	Compact disc
DC	Direct current
EEPROM	Electrically erasable programmable read-only memory
EMC	Electromagnetic compatibility
EMI	Electromagnetic interference
ETR	Electronic thermal relay
GND	Ground
Hp	Horsepower
Hz	Hertz
IGBT	Insulated-gate bipolar transistor
IP	Ingress protection
kHz	Kilohertz
kW	Kilowatt
kWh	Kilowatt hour
LCP	Local control panel
mA	Milliamp
MCT	Motion control tool
MDCIC	Multi-drive control interface card
PC	Personal computer
PELV	Protective extra low voltage
PID	Proportional integral derivative
PM Motor	Permanent magnet motor
PTC thermistor	Positive temperature coefficient thermistor
PUD	Power unit data
PWM	Pulse width modulation
Regen	Regeneration
RFI	Radio frequency interference
RMS	Root mean square (cyclically alternating electric current)
RPM	Revolutions per minute
RS485	Multipoint communications standard using a 2-wire, twisted-pair bus
s	Second (time)
SCCR	Short circuit current rating
SLC	SL controller
SMS	Switched-mode power supply
STO	Safe Torque Off
THD	Total harmonic distortion
UPS	Uninterruptible power supply
USB	Universal serial bus
V	Volt

Table 8.1 Symbols and Abbreviations

Conventions

Numbered lists show procedures.

Bullet lists show additional information.

Italicized text shows cross-references, links, and parameters.

All measurements are presented as metric units (imperial units).

8.2 International/North American Default Parameter Settings

Setting *parameter 0-03 Regional Settings* to [0] *International* or [1] *North America* changes the default settings for some parameters. Table 8.2 lists those parameters that are affected. Changes made to the default settings are stored. They are available for viewing in the quick menu, along with any programming entered into the parameters.

Parameter	International Default Parameter Value	North American Default Parameter Value
<i>Parameter 0-03 Regional Settings</i>	International	North America
<i>Parameter 0-71 Date Format</i>	DD-MM-YYYY	MM/DD/YYYY
<i>Parameter 0-72 Time Format</i>	24 h	12 h
<i>Parameter 1-20 Motor Power [kW]</i>	See Note ¹⁾	See Note ¹⁾
<i>Parameter 1-21 Motor Power [HP]</i>	See Note ²⁾	See Note ²⁾
<i>Parameter 1-22 Motor Voltage</i>	230 V/400 V/575 V	208 V/460 V/575 V
<i>Parameter 1-23 Motor Frequency</i>	50 Hz	60 Hz
<i>Parameter 3-03 Maximum Reference</i>	50 Hz	60 Hz
<i>Parameter 3-04 Reference Function</i>	Sum	External/Preset
<i>Parameter 4-13 Motor Speed High Limit [RPM]³⁾</i>	1500 RPM	1800 RPM
<i>Parameter 4-14 Motor Speed High Limit [Hz]⁴⁾</i>	50 Hz	60 Hz
<i>Parameter 4-19 Max Output Frequency</i>	100 Hz	120 Hz
<i>Parameter 4-53 Warning Speed High</i>	1500 RPM	1800 RPM
<i>Parameter 5-12 Terminal 27 Digital Input</i>	Coast inverse	External interlock
<i>Parameter 5-40 Function Relay</i>	Alarm	No alarm
<i>Parameter 6-15 Terminal 53 High Ref./Feedb. Value</i>	50	60
<i>Parameter 6-50 Terminal 42 Output</i>	Speed 0–HighLim	Speed 4–20 mA
<i>Parameter 14-20 Reset Mode</i>	Manual reset	Infinite auto reset
<i>Parameter 22-85 Speed at Design Point [RPM]³⁾</i>	1500 RPM	1800 RPM
<i>Parameter 22-86 Speed at Design Point [Hz]</i>	50 Hz	60 Hz
<i>Parameter 24-04 Fire Mode Max Reference</i>	50 Hz	60 Hz

Table 8.2 International/North American Default Parameter Settings

1) *Parameter 1-20 Motor Power [kW]* is visible only when *parameter 0-03 Regional Settings* is set to [0] *International*.

2) *Parameter 1-21 Motor Power [HP]* is visible only when *parameter 0-03 Regional Settings* is set to [1] *North America*.

3) This parameter is visible only when *parameter 0-02 Motor Speed Unit* is set to [0] *RPM*.

4) This parameter is visible only when *parameter 0-02 Motor Speed Unit* is set to [1] *Hz*.

8.3 Parameter Menu Structure

Certain parameters are specific to the drive system. For a list of these parameters and all other system parameters, including descriptions, refer to the *programming guide* applicable to the series of drive modules used in creating the drive system.

8.3.1 Main Menu Structure

Operation / Display	DC-Brake	Reference Site	Terminal
0-0** Basic Settings	2-00 DC Hold/Preheat Current	3-13 Reference Site	5-13 Terminal 29 Digital Input
0-01 Language	2-01 DC Brake Current	3-14 Preset Relative Reference	5-14 Terminal 32 Digital Input
0-02 Motor Speed Unit	2-02 DC Braking Time	3-15 Reference 1 Source	5-15 Terminal 33 Digital Input
0-03 Regional Settings	2-03 DC Brake Cut In Speed [RPM]	3-16 Reference 2 Source	5-16 Terminal X30/2 Digital Input
0-04 Operating State at Power-up	2-04 DC Brake Cut In Speed [Hz]	3-17 Reference 3 Source	5-17 Terminal X30/3 Digital Input
0-05 Local Mode Unit	2-06 Parking Current	3-19 Jog Speed [RPM]	5-18 Terminal X30/4 Digital Input
0-1* Set-up Operations	2-07 Parking Time	3-41 Ramp 1	5-19 Terminal 37 Safe Stop
0-10 Active Set-up	2-1* Brake Energy Funct.	3-42 Ramp 1 Ramp Up Time	5-3* Digital Outputs
0-11 Programming Set-up	2-10 Brake Function	3-43 Ramp 2	5-30 Terminal 27 Digital Output
0-12 This Set-up Linked to	2-11 Brake Resistor (ohm)	3-51 Ramp 2 Ramp Up Time	5-31 Terminal 29 Digital Output
0-13 Readout: Linked Set-ups	2-12 Brake Power Limit (kW)	3-52 Ramp 2 Ramp Down Time	5-32 Term X30/6 Digi Out (MCB 101)
0-14 Readout: Prog. Set-ups / Channel	2-13 Brake Power Monitoring	3-53 Ramp 2 Ramp Down Time	5-33 Term X30/7 Digi Out (MCB 101)
0-2* LCP Display	2-15 Brake Check	3-80 Other Ramps	5-4* Relays
0-20 Display Line 1.1 Small	2-16 AC brake Max. Current	3-81 Jog Ramp Time	5-40 Function Relay
0-21 Display Line 1.2 Small	2-17 Over-voltage Control	3-82 Quick Stop Ramp Time	5-41 On Delay, Relay
0-22 Display Line 1.3 Small	2-2* Mechanical Brake	3-82 Starting Ramp Up Time	5-42 Off Delay, Relay
0-23 Display Line 2 Large	2-20 Release Brake Current	3-90 Step Size	5-5* Pulse Input
0-24 Display Line 3 Large	2-21 Activate Brake Speed [RPM]	3-91 Ramp Time	5-50 Term. 29 Low Frequency
0-25 My Personal Menu	2-23 Activate Brake Delay	3-92 Power Restore	5-51 Term. 29 High Frequency
0-3* LCP Custom Readout	2-4* AFE Limits and Func. Setting	3-93 Maximum Limit	5-52 Term. 29 Low Ref./Feedb. Value
0-30 Custom Readout Unit	2-41 DC Voltage Upper Limit	3-94 Minimum Limit	5-53 Term. 29 High Ref./Feedb. Value
0-31 Custom Readout Min Value	2-43 Regen Current Limit	3-95 Ramp Delay	5-54 Pulse Filter Time Constant #29
0-32 Custom Readout Max Value	2-44 Function at Over Temperature	4-** Limits / Warnings	5-55 Term. 33 Low Frequency
0-33 Display Text 1	2-45 Over Temperature Derate Current	4-1* Motor Limits	5-56 Term. 33 High Frequency
0-38 Display Text 2	2-46 Nominal Mains Voltage	4-10 Motor Speed Direction	5-57 Term. 33 Low Ref./Feedb. Value
0-39 Display Text 3	2-47 Sleep Mode Enable	4-11 Motor Speed Low Limit [RPM]	5-58 Term. 33 High Ref./Feedb. Value
0-4* LCP keypad	2-48 Sleep Mode Trig Source	4-12 Motor Speed High Limit [RPM]	5-59 Pulse Filter Time Constant #33
0-40 [Hand on] Key on LCP	2-49 Sleep Mode Delay	4-13 Motor Speed Low Limit [Hz]	5-6* Pulse Output
0-41 [Off] Key on LCP	2-5* AFE Ref. Setting	4-14 Motor Speed High Limit [Hz]	5-60 Terminal 27 Pulse Output Variable
0-42 [Auto on] Key on LCP	2-50 Phi Reference	4-16 Torque Limit Motor Mode	5-61 Pulse Output Max Freq #27
0-43 [Reset] Key on LCP	2-51 kVar Reference	4-17 Torque Limit Generator Mode	5-62 Pulse Output Max Freq #29
0-44 [Off/Reset] Key on LCP	2-52 Power Factor Reference	4-18 Current Limit	5-65 Pulse Output Max Freq #29
0-45 [Drive Bypass] Key on LCP	2-53 Reactive Current Reference	4-19 Max Output Frequency	5-66 Terminal X30/6 Pulse Output Variable
0-5* Copy/Save	2-54 Reactive Current Reference Resource	4-5* Adj. Warnings	5-68 Pulse Output Max Freq #X30/6
0-50 LCP Copy	2-55 Reactive Current Ramp Up Time	4-50 Warning Current Low	5-8* I/O Options
0-51 Set-up Copy	2-56 Reactive Current Ramp Down Time	4-51 Warning Current High	5-80 AHF Cap Reconnect Delay
0-6* Password	2-57 DC-Link Voltage Reference Resource	4-52 Warning Speed Low	5-9* Bus Controlled
0-60 Main Menu Password	2-58 DC-Link Voltage Reference	4-53 Warning Speed High	5-90 Digital & Relay Bus Control
0-61 Access to Main Menu w/o Password	2-6* AFE Setting (Other)	4-54 Warning Reference Low	5-93 Pulse Out #27 Bus Control
0-65 Personal Menu Password	2-62 Stop CMD Response	4-55 Warning Reference High	5-94 Pulse Out #27 Timeout Preset
0-66 Access to Personal Menu w/o Password	2-7* AFE Internal Readout	4-56 Warning Feedback Low	5-95 Pulse Out #29 Bus Control
0-7* Clock Settings	2-70 AIC L1 Current	4-57 Warning Feedback High	5-96 Pulse Out #29 Timeout Preset
0-70 Date and Time	2-71 AIC L2 Current	4-58 Missing Motor Phase Function	5-97 Pulse Out #X30/6 Bus Control
0-71 Date Format	2-72 AIC L3 Current	4-6* Speed Bypass	5-98 Pulse Out #X30/6 Timeout Preset
0-72 Time Format	2-73 AIC Thermal	6-0* Analog I/O Mode	6-0* Analog I/O Mode
0-74 DST/Summertime	2-74 AIC Running Hours	6-00 Live Zero Timeout Time	6-00 Live Zero Timeout Function
0-76 DST/Summertime Start	2-75 AIC Start Counter	6-01 Live Zero Timeout Function	6-01 Live Zero Timeout Function
0-77 DST/Summertime End	2-76 AIC Current Limit	6-02 Fire Mode Live Zero Timeout Function	6-02 Fire Mode Live Zero Timeout Function
0-79 Clock Fault	3-** Reference / Ramps	6-1* Analog Input 53	6-1* Analog Input 53
0-81 Working Days	3-00 Reference Limits	6-10 Terminal 53 Low Voltage	6-10 Terminal 53 Low Voltage
0-82 Additional Working Days	3-02 Minimum Reference	6-11 Terminal 53 High Voltage	6-11 Terminal 53 High Voltage
0-83 Additional Non-Working Days	3-03 Maximum Reference	6-12 Terminal 53 Low Current	6-12 Terminal 53 Low Current
0-89 Date and Time Readout	3-04 Reference Function	6-13 Terminal 53 High Current	6-13 Terminal 53 High Current
1-1** Load and Motor	3-10 Preset Reference	6-14 Terminal 53 Low Ref./Feedb. Value	6-14 Terminal 53 Low Ref./Feedb. Value
1-1** Load and Motor	3-11 Jog Speed [Hz]	6-15 Terminal 53 High Ref./Feedb. Value	6-15 Terminal 53 High Ref./Feedb. Value
2-** Brakes		6-16 Terminal 53 Filter Time Constant	6-16 Terminal 53 Filter Time Constant
2-** Brakes		6-17 Terminal 53 Live Zero	6-17 Terminal 53 Live Zero



6-2*	Analog Input 54	8-4*	FC MC protocol set	9-90	Changed Parameters (1)	12-13	Link Speed	14-0*	Inverter Switching
6-20	Terminal 54 Low Voltage	8-40	Telegram Selection	9-91	Changed Parameters (2)	12-14	Link Duplex	14-00	Switching Pattern
6-21	Terminal 54 High Voltage	8-42	PCD write configuration	9-92	Changed Parameters (3)	12-2*	Process Data	14-01	Switching Frequency
6-22	Terminal 54 Low Current	8-43	PCD read configuration	9-93	Changed Parameters (4)	12-20	Control Instance	14-03	Overmodulation
6-23	Terminal 54 High Current	8-5*	Digital/Bus	9-94	Changed Parameters (5)	12-21	Process Data Config Write	14-04	PWM Random
6-24	Terminal 54 Low Ref./Feedb. Value	8-50	Coasting Select	9-99	Profibus Revision Counter	12-22	Process Data Config Read	14-1*	Mains On/Off
6-25	Terminal 54 High Ref./Feedb. Value	8-52	DC Brake Select	10-0*	CAN Fieldbus	12-27	Primary Master	14-10	Mains Failure
6-26	Terminal 54 Filter Time Constant	8-53	Start Select	10-0*	Common Settings	12-28	Store Data Values	14-11	Mains Voltage at Mains Fault
6-27	Terminal 54 Live Zero	8-54	Reversing Select	10-00	CAN Protocol	12-29	Store Always	14-12	Function at Mains Imbalance
6-3*	Analog Input X30/11	8-55	Set-up Select	10-02	MAC ID	12-3*	EtherNet/IP	14-2*	Reset Functions
6-30	Terminal X30/11 Low Voltage	8-56	Preset Reference Select	10-02	BAUD ID	12-30	Warning Parameter	14-20	Reset Mode
6-31	Terminal X30/11 High Voltage	8-7*	BACnet	10-05	Readout Transmit Error Counter	12-31	Net Reference	14-21	Automatic Restart Time
6-34	Term. X30/11 Low Ref./Feedb. Value	8-70	BACnet Device Instance	10-07	Readout Receive Error Counter	12-32	Net Control	14-22	Operation Mode
6-35	Term. X30/11 High Ref./Feedb. Value	8-72	MS/TP Max Masters	10-07	Readout Bus Off Counter	12-33	CIP Revision	14-23	Typecode Setting
6-36	Term. X30/11 Filter Time Constant	8-73	MS/TP Max Info Frames	10-1*	DeviceNet	12-34	CIP Product Code	14-25	Trip Delay at Torque Limit
6-37	Term. X30/11 Live Zero	8-74	"I-Am" Service	10-10	Process Data Type Selection	12-35	EDS Parameter	14-26	Trip Delay at Inverter Fault
6-4*	Analog Input X30/12	8-75	Initialisation Password	10-11	Process Data Config Write	12-37	COS Inhibit Timer	14-28	Production Settings
6-40	Terminal X30/12 Low Voltage	8-8*	FC Port Diagnostics	10-12	Process Data Config Read	12-38	COS Filter	14-29	Service Code
6-41	Terminal X30/12 High Voltage	8-80	Bus Message Count	10-13	Warning Parameter	12-4*	Modbus TCP	14-3*	Current Limit Ctrl.
6-44	Term. X30/12 Low Ref./Feedb. Value	8-81	Bus Error Count	10-14	Net Reference	12-40	Status Parameter	14-30	Current Lim Ctrl, Proportional Gain
6-45	Term. X30/12 High Ref./Feedb. Value	8-82	Slave Messages Rcvd	10-15	Net Control	12-41	Slave Message Count	14-31	Current Lim Ctrl, Integration Time
6-46	Term. X30/12 Filter Time Constant	8-83	Slave Error Count	10-20	COS Filters	12-42	Slave Exception Message Count	14-32	Current Lim Ctrl, Filter Time
6-47	Term. X30/12 Live Zero	8-84	Slave Messages Sent	10-21	COS Filter 1	12-8*	Other Ethernet Services	14-4*	Energy Optimising
6-5*	Analog Output 42	8-85	Slave Timeout Errors	10-22	COS Filter 2	12-80	FTP Server	14-40	VT Level
6-50	Terminal 42 Output	8-89	Diagnostics Count	10-23	COS Filter 3	12-81	HTTP Server	14-41	AEO Minimum Magnetisation
6-51	Terminal 42 Output Min Scale	8-9*	Bus Jog / Feedback	10-23	COS Filter 4	12-82	SMTP Service	14-42	Minimum AEO Frequency
6-52	Terminal 42 Output Max Scale	8-90	Bus Jog 1 Speed	10-3*	Parameter Access	12-89	Transparent Socket Channel Port	14-43	Motor Cosphi
6-53	Terminal 42 Output Bus Control	8-91	Bus Jog 2 Speed	10-30	Array Index	12-9*	Advanced Ethernet Services	14-5*	Environment
6-54	Terminal 42 Output Timeout Preset	8-94	Bus Feedback 1	10-31	Store Data Values	12-90	Cable Diagnostic	14-50	RFI Filter
6-55	Analog Output Filter	8-95	Bus Feedback 2	10-32	DeviceNet Revision	12-91	Auto Cross Over	14-51	DC Link Compensation
6-6*	Analog Output X30/8	8-96	Bus Feedback 3	10-33	Store Always	12-92	IGMP Snooping	14-52	Fan Control
6-60	Terminal X30/8 Output	9-*	Profibus	10-34	DeviceNet Product Code	12-93	Cable Error Length	14-53	Fan Monitor
6-61	Terminal X30/8 Min. Scale	9-00	Setpoint	10-39	DeviceNet F Parameters	12-94	Broadcast Storm Protection	14-55	Output Filter
6-62	Terminal X30/8 Max. Scale	9-07	Actual Value	11-0*	LonWorks ID	12-95	Broadcast Storm Filter	14-59	Actual Number of Inverter Units
6-63	Terminal X30/8 Output Bus Control	9-15	PCD Write Configuration	11-00	Neuron ID	12-96	Port Config	14-60	Function at Over Temperature
6-64	Terminal X30/8 Output Timeout Preset	9-16	PCD Read Configuration	11-1*	LonWorks ID	12-98	Interface Counters	14-61	Function at Inverter Overload
8-0*	Comm. and Options	9-18	Node Address	11-1*	Lon Functions	12-99	Media Counters	14-62	Inv. Overload Derate Current
8-01	Control Site	9-22	Telegram Selection	11-10	Drive Profile	13-*	Smart Logic	15-*	Drive Information
8-02	Control Source	9-23	Parameters for Signals	11-15	LON Warning Word	13-0*	SLC Settings	15-0*	Operating Data
8-03	Control Timeout Time	9-27	Parameter Edit	11-17	XIF Revision	13-00	SL Controller Mode	15-00	Operating Hours
8-04	Control Timeout Function	9-28	Process Control	11-18	LonWorks Revision	13-01	Start Event	15-01	Running Hours
8-05	End-of-Timeout Function	9-45	Fault Message Counter	11-2*	LON Param. Access	13-02	Stop Event	15-02	kWh Counter
8-06	Reset Control Timeout	9-45	Fault Code	11-21	Store Data Values	13-03	Reset SLC	15-03	Power Up's
8-07	Diagnosis Trigger	9-47	Fault Number	12-*	Ethernet	13-1*	Comparators	15-04	Over Temp's
8-08	Readout Filtering	9-52	Fault Situation Counter	12-0*	IP Settings	13-10	Comparator Operand	15-05	Over Volt's
8-09	Communication Charset	9-53	Profibus Warning Word	12-00	IP Address Assignment	13-11	Comparator Operator	15-06	Reset kWh Counter
8-1*	Control Settings	9-63	Actual Baud Rate	12-01	IP Address	13-12	Comparator Value	15-07	Reset Running Hours Counter
8-10	Control Profile	9-65	Device Identification	12-02	Subnet Mask	13-2*	Timers	15-08	Number of Starts
8-13	Configurable Status Word STW	9-65	Profile Number	12-03	Default Gateway	13-20	SL Controller Timer	15-1*	Data Log Settings
8-3*	Protocol	9-67	Control Word 1	12-04	DHCP Server	13-4*	Logic Rules	15-10	Logging Source
8-30	Address	9-68	Status Word 1	12-05	Lease Expires	13-40	Logic Rule Boolean 1	15-11	Logging Interval
8-31	Baud Rate	9-71	Profibus Save Data Values	12-06	Name Servers	13-41	Logic Rule Operator 1	15-12	Trigger Event
8-32	Parity / Stop Bits	9-72	ProfibusDriveReset	12-07	Domain Name	13-42	Logic Rule Boolean 2	15-13	Logging Mode
8-33	Estimated cycle time	9-75	DO Identification	12-08	Host Name	13-43	Logic Rule Operator 2	15-14	Samples Before Trigger
8-34	Minimum Response Delay	9-80	Defined Parameters (1)	12-09	Physical Address	13-44	Logic Rule Boolean 3	15-2*	Historic Log
8-35	Maximum Response Delay	9-81	Defined Parameters (2)	12-10	Ethernet Link Parameters	13-5*	States	15-20	Historic Log: Event
8-36	Maximum Inter-Char Delay	9-82	Defined Parameters (3)	12-11	Link Status	13-51	SL Controller Event	15-21	Historic Log: Value
8-37		9-83	Defined Parameters (4)	12-12	Link Duration	13-52	SL Controller Action	15-22	Historic Log: Time
		9-84	Defined Parameters (5)		Auto Negotiation	14-*	Special Functions		

15-23	Historic Log: Date and Time	16-16	Torque [Nm]	18-0*	Maintenance Log	20-30	Refrigerant	21-34	Ext. 2 Feedback Source
15-3*	Alarm Log	16-17	Speed [RPM]	18-00	Maintenance Log: Item	20-31	User Defined Refrigerant A1	21-35	Ext. 2 Setpoint
15-30	Alarm Log: Error Code	16-18	Motor Thermal	18-01	Maintenance Log: Action	20-32	User Defined Refrigerant A2	21-37	Ext. 2 Reference [Unit]
15-31	Alarm Log: Value	16-22	Torque [%]	18-02	Maintenance Log: Time	20-33	User Defined Refrigerant A3	21-38	Ext. 2 Feedback [Unit]
15-32	Alarm Log: Time	16-26	Power Filtered [kW]	18-03	Maintenance Log: Date and Time	20-34	Duct 1 Area [m2]	21-39	Ext. 2 Output [%]
15-33	Alarm Log: Date and Time	16-27	Power Filtered [hp]	18-1*	Fire Mode Log	20-35	Duct 1 Area [in2]	21-4*	Ext. CL 2 PID
15-4*	Drive Identification	16-3*	Drive Status	18-10	Fire Mode Log: Event	20-36	Duct 2 Area [m2]	21-40	Ext. 2 Normal/Inverse Control
15-40	FC Type	16-30	DC Link Voltage	18-11	Fire Mode Log: Time	20-37	Duct 2 Area [in2]	21-41	Ext. 2 Proportional Gain
15-41	Power Section	16-34	Heatsink Temp.	18-12	Fire Mode Log: Date and Time	20-38	Air Density Factor [%]	21-42	Ext. 2 Integral Time
15-42	Voltage	16-35	Inverter Thermal	18-2*	AFF Performance	20-6*	Sensorless	21-43	Ext. 2 Differentiation Time
15-43	Software Version	16-36	Inv. Nom. Current	18-20	THD of Voltage [%]	20-60	Sensorless Unit	21-44	Ext. 2 Dif. Gain Limit
15-44	Ordered Typecode String	16-37	Inv. Max. Current	18-21	Reactive Current	20-69	Sensorless Information	21-5*	Ext. CL 3 Ref/Fb.
15-45	Actual Typecode String	16-38	SL Controller State	18-23	Available kVars	20-7*	PID Autotuning	21-50	Ext. 3 Ref/Feedback Unit
15-46	Frequency Converter Ordering No	16-39	Control Card Temp.	18-23	Available Reactive Current	20-70	Closed Loop Type	21-51	Ext. 3 Minimum Reference
15-47	Power Card Ordering No	16-40	Logging Buffer Full	18-24	Power Factor	20-71	PID Performance	21-52	Ext. 3 Maximum Reference
15-48	LCP Id No	16-41	Logging Buffer Full	18-28	Sensor Failures	20-72	PID Output Change	21-53	Ext. 3 Reference Source
15-49	SW ID Control Card	16-43	Timed Actions Status	18-29	Fan Power Card Failures	20-73	Minimum Feedback Level	21-54	Ext. 3 Feedback Source
15-50	SW ID Power Card	16-49	Current Fault Source	18-3*	Inputs & Outputs	20-74	Maximum Feedback Level	21-55	Ext. 3 Setpoint
15-51	Frequency Converter Serial Number	16-5*	Ref. & Feeds.	18-30	Analog Input X42/1	20-79	PID Autotuning	21-57	Ext. 3 Reference [Unit]
15-53	Power Card Serial Number	16-50	External Reference	18-31	Analog Input X42/3	20-8*	PID Basic Settings	21-58	Ext. 3 Feedback [Unit]
15-55	Vendor URL	16-52	Feedback [Unit]	18-32	Analog Input X42/5	20-81	PID Normal/ Inverse Control	21-59	Ext. 3 Output [%]
15-56	Vendor Name	16-53	Digi Pot Reference	18-33	Analog Out X42/7 [V]	20-82	PID Start Speed [RPM]	21-6*	Ext. CL 3 PID
15-59	CSIV Filename	16-54	Feedback 1 [Unit]	18-34	Analog Out X42/9 [V]	20-83	PID Start Speed [Hz]	21-60	Ext. 3 Normal/Inverse Control
15-6*	Option Ident	16-55	Feedback 2 [Unit]	18-35	Analog Out X42/11 [V]	20-84	On Reference Bandwidth	21-61	Ext. 3 Proportional Gain
15-60	Option Mounted	16-56	Feedback 3 [Unit]	18-36	Analog Input X48/2 [mA]	20-9*	PID Controller	21-62	Ext. 3 Integral Time
15-61	Option SW Version	16-58	PID Output [%]	18-37	Temp. Input X48/4	20-91	PID Anti Windup	21-63	Ext. 3 Differentiation Time
15-62	Option Ordering No	16-6*	Inputs & Outputs	18-38	Temp. Input X48/7	20-93	PID Proportional Gain	21-64	Ext. 3 Dif. Gain Limit
15-63	Option Serial No	16-60	Digital Input	18-39	Temp. Input X48/10	20-94	PID Integral Time	22-0*	Appl. Functions
15-70	Option in Slot A	16-61	Terminal 53 Switch Setting	18-5*	Ref. & Feeds.	20-95	PID Differentiation Time	22-0*	Miscellaneous
15-71	Slot A Option SW Version	16-62	Analog Input 53	18-50	Sensorless Readout [Unit]	20-96	PID Diff. Gain Limit	22-00	External Interlock Delay
15-72	Option in Slot B	16-63	Terminal 54 Switch Setting	18-7*	AFF Statistics	21-1*	Ext. Closed Loop	22-01	Power Filter Time
15-73	Slot B Option SW Version	16-64	Analog Input 54	18-70	Mains Current Fund [A]	21-0*	Ext. CL Autotuning	22-2*	No-Flow Detection
15-74	Option in Slot C0	16-65	Analog Output 42 [mA]	18-71	Mains Current [%]	21-00	Closed Loop Type	22-20	Low Power Auto Set-up
15-75	Slot C0 Option SW Version	16-66	Digital Output [bin]	18-72	Regen kWh	21-01	PID Performance	22-21	Low Power Detection
15-76	Option in Slot C1	16-67	Pulse Input #29 [Hz]	18-73	Regen Total Time	21-02	PID Output Change	22-22	Low Speed Detection
15-77	Slot C1 Option SW Version	16-68	Pulse Input #33 [Hz]	18-74	Mains Voltage	21-03	Minimum Feedback Level	22-23	No-Flow Function
15-8*	Operating Data II	16-69	Pulse Output #27 [Hz]	18-75	Mains Frequency	21-04	Maximum Feedback Level	22-24	No-Flow Delay
15-80	Fan Running Hours	16-70	Pulse Output #29 [Hz]	18-78	AIC Alarm Word	21-09	PID Autotuning	22-26	Dry Pump Function
15-81	Preset Fan Running Hours	16-71	Relay Output [bin]	18-79	AIC Warning Word	21-1*	Ext. CL 1 Ref/Fb.	22-27	Dry Pump Delay
15-9*	Parameter Info	16-72	Counter A	20-0*	Drive Closed Loop	21-10	Ext. 1 Ref/Feedback Unit	22-3*	No-Flow Power Tuning
15-92	Defined Parameters	16-73	Counter B	20-0*	Feedback	21-11	Ext. 1 Minimum Reference	22-30	No-Flow Power
15-93	Modified Parameters	16-75	Analog In X30/11	20-00	Feedback 1 Source	21-12	Ext. 1 Maximum Reference	22-31	Power Correction Factor
15-98	Drive Identification	16-76	Analog In X30/12	20-01	Feedback 1 Conversion	21-13	Ext. 1 Reference Source	22-32	Low Speed [RPM]
15-99	Parameter Metadata	16-77	Analog Out X30/8 [mA]	20-02	Feedback 1 Source Unit	21-14	Ext. 1 Feedback Source	22-33	Low Speed [Hz]
16-0*	Data Readouts	16-8*	Fieldbus & FC Port	20-03	Feedback 2 Source	21-15	Ext. 1 Setpoint	22-34	Low Speed Power [kW]
16-0*	General Status	16-80	Fieldbus CTW 1	20-04	Feedback 2 Conversion	21-17	Ext. 1 Reference [Unit]	22-35	Low Speed Power [HP]
16-00	Control Word	16-82	Fieldbus REF 1	20-06	Feedback 2 Source Unit	21-18	Ext. 1 Feedback [Unit]	22-36	High Speed [RPM]
16-01	Reference [Unit]	16-84	Comm. Option STW	20-06	Feedback 3 Source	21-19	Ext. 1 Output [%]	22-37	High Speed [Hz]
16-02	Reference [%]	16-85	FC Port CTW 1	20-07	Feedback 3 Conversion	21-2*	Ext. CL 1 PID	22-38	High Speed Power [kW]
16-03	Status Word	16-86	FC Port REF 1	20-08	Feedback 3 Source Unit	21-20	Ext. 1 Normal/Inverse Control	22-38	High Speed Power [HP]
16-05	Main Actual Value [%]	16-9*	Diagnosis Readouts	20-12	Reference/Feedback Unit	21-21	Ext. 1 Proportional Gain	22-4*	Sleep Mode
16-09	Custom Readout	16-90	Alarm Word 1	20-13	Minimum Reference/Feedb.	21-22	Ext. 1 Integral Time	22-40	Minimum Run Time
16-1*	Motor Status	16-91	Alarm Word 2	20-14	Maximum Reference/Feedb.	21-23	Ext. 1 Differentiation Time	22-41	Minimum Speed Time
16-10	Power [kW]	16-92	Warning Word	20-2*	Feedback/Setpoint	21-24	Ext. 1 Dif. Gain Limit	22-42	Wake-up Speed [RPM]
16-11	Power [hp]	16-93	Warning Word 2	20-20	Feedback Function	21-3*	Ext. CL 2 Ref/Fb.	22-43	Wake-up Speed [Hz]
16-12	Motor Voltage	16-94	Ext. Status Word	20-21	Setpoint 1	21-30	Ext. 2 Ref/Feedback Unit	22-44	Wake-up Ref/FB Difference
16-13	Frequency	16-95	Ext. Status Word 2	20-22	Setpoint 2	21-31	Ext. 2 Minimum Reference	22-45	Setpoint Boost
16-14	Motor Current	16-96	Maintenance Word	20-23	Setpoint 3	21-32	Ext. 2 Maximum Reference	22-46	Maximum Boost Time
16-15	Frequency [%]	18-0*	Info & Readouts	20-3*	Feedb. Adv. Conv.	21-33	Ext. 2 Reference Source		



22-5*	End of Curve	23-80	Power Reference Factor	25-50	Lead Pump Alternation	26-60	Terminal X42/11 Output
22-50	End of Curve Function	23-81	Energy Cost	25-51	Alternation Event	26-61	Terminal X42/11 Min. Scale
22-51	End of Curve Delay	23-82	Investment	25-52	Alternation Time Interval	26-62	Terminal X42/11 Max. Scale
22-6*	Broken Belt Detection	23-83	Energy Savings	25-53	Alternation Timer Value	26-63	Terminal X42/11 Bus Control
22-60	Broken Belt Function	23-84	Cost Savings	25-54	Alternation Predefined Time	26-64	Terminal X42/11 Timeout Preset
22-61	Broken Belt Torque	24-0*	Appl. Functions 2	25-55	Alternate if Load < 50%	30-0*	Special Features
22-62	Broken Belt Delay	24-0*	Fire Mode	25-56	Staging Mode at Alternation	30-8*	Compatibility (I)
22-7*	Short Cycle Protection	24-00	Fire Mode Function	25-58	Run Next Pump Delay	30-83	Speed PID Proportional Gain
22-75	Short Cycle Protection	24-01	Fire Mode Configuration	25-59	Run on Mains Delay	30-84	Process PID Proportional Gain
22-76	Interval between Starts	24-02	Fire Mode Unit	25-8*	Status	31-00	Bypass Option
22-77	Minimum Run Time	24-03	Fire Mode Min Reference	25-80	Cascade Status	31-00	Bypass Mode
22-78	Minimum Run Time Override	24-04	Fire Mode Max Reference	25-81	Pump Status	31-01	Bypass Start Time Delay
22-8*	Flow Compensation	24-05	Fire Mode Preset Reference	25-82	Lead Pump	31-02	Bypass Trip Time Delay
22-80	Flow Compensation	24-06	Fire Mode Reference Source	25-83	Relay Status	31-03	Test Mode Activation
22-81	Square-linear Curve Approximation	24-07	Fire Mode Feedback Source	25-84	Pump ON Time	31-10	Bypass Status Word
22-82	Work Point Calculation	24-09	Fire Mode Alarm Handling	25-85	Relay ON Time	31-11	Bypass Running Hours
22-83	Speed at No-Flow [RPM]	24-1*	Drive Bypass	25-86	Reset Relay Counters	31-19	Remote Bypass Activation
22-84	Speed at No-Flow [Hz]	24-10	Drive Bypass Function	25-9*	Service	35-0*	Sensor Input Option
22-85	Speed at Design Point [RPM]	24-11	Drive Bypass Delay Time	25-90	Pump Interlock	35-00	Temp. Input Mode
22-86	Speed at Design Point [Hz]	24-9*	Multi-Motor Funct.	25-91	Manual Alternation	35-00	Temp. X48/4 Temp. Unit
22-87	Pressure at No-Flow Speed	24-90	Missing Motor Function	26-0*	Analog I/O Option	35-01	Term. X48/4 Input Type
22-88	Pressure at Rated Speed	24-91	Missing Motor Coefficient 1	26-00	Terminal X42/1 Mode	35-02	Term. X48/7 Temp. Unit
22-89	Flow at Design Point	24-92	Missing Motor Coefficient 2	26-01	Terminal X42/3 Mode	35-03	Term. X48/7 Input Type
22-90	Flow at Rated Speed	24-93	Missing Motor Coefficient 3	26-01	Terminal X42/3 Mode	35-04	Term. X48/10 Temp. Unit
23-0*	Time-based Functions	24-94	Missing Motor Coefficient 4	26-02	Terminal X42/5 Mode	35-05	Term. X48/10 Input Type
23-00	Timed Actions	24-95	Locked Rotor Function	26-1*	Analog Input X42/1	35-06	Temperature Sensor Alarm Function
23-00	ON Time	24-96	Locked Rotor Coefficient 1	26-10	Terminal X42/1 Low Voltage	35-1*	Temp. Input X48/4
23-01	ON Action	24-97	Locked Rotor Coefficient 2	26-11	Terminal X42/1 High Voltage	35-14	Term. X48/4 Filter Time Constant
23-02	OFF Time	24-98	Locked Rotor Coefficient 3	26-14	Term. X42/1 Low Ref./Feedb. Value	35-15	Term. X48/4 Temp. Monitor
23-03	OFF Action	24-99	Locked Rotor Coefficient 4	26-15	Term. X42/1 High Ref./Feedb. Value	35-16	Term. X48/4 Low Temp. Limit
23-04	Occurrence	25-0*	Cascade Controller	26-16	Term. X42/1 Filter Time Constant	35-17	Term. X48/4 High Temp. Limit
23-0*	Timed Actions Settings	25-00	Cascade Controller	26-17	Term. X42/1 Live Zero	35-2*	Temp. Input X48/7
23-08	Timed Actions Mode	25-02	Motor Start	26-2*	Analog Input X42/3	35-24	Term. X48/7 Filter Time Constant
23-09	Timed Actions Reactivation	25-04	Pump Cycling	26-20	Terminal X42/3 Low Voltage	35-25	Term. X48/7 Temp. Monitor
23-1*	Maintenance	25-05	Fixed Lead Pump	26-21	Terminal X42/3 High Voltage	35-26	Term. X48/7 Low Temp. Limit
23-10	Maintenance Item	25-06	Number of Pumps	26-24	Term. X42/3 Low Ref./Feedb. Value	35-27	Term. X48/7 High Temp. Limit
23-11	Maintenance Action	25-2*	Bandwidth Settings	26-25	Term. X42/3 High Ref./Feedb. Value	35-3*	Temp. Input X48/10
23-12	Maintenance Time Base	25-20	Staging Bandwidth	26-26	Term. X42/3 Filter Time Constant	35-34	Term. X48/10 Filter Time Constant
23-13	Maintenance Time Interval	25-21	Override Bandwidth	26-27	Term. X42/3 Live Zero	35-35	Term. X48/10 Temp. Monitor
23-14	Maintenance Date and Time	25-22	Fixed Speed Bandwidth	26-30	Analog Input X42/5	35-36	Term. X48/10 Low Temp. Limit
23-1*	Maintenance Reset	25-23	SBW Staging Delay	26-31	Terminal X42/5 High Voltage	35-37	Term. X48/10 High Temp. Limit
23-15	Reset Maintenance Word	25-24	SBW Destaging Delay	26-34	Term. X42/5 Low Ref./Feedb. Value	35-4*	Analog Input X48/2
23-16	Maintenance Text	25-25	OBW Time	26-35	Term. X42/5 High Ref./Feedb. Value	35-43	Term. X48/2 High Current
23-5*	Energy Log	25-26	Destage At No-Flow	26-36	Term. X42/5 Filter Time Constant	35-44	Term. X48/2 Low Ref./Feedb. Value
23-50	Energy Log Resolution	25-27	Stage Function	26-37	Term. X42/5 Live Zero	35-45	Term. X48/2 High Ref./Feedb. Value
23-51	Period Start	25-28	Stage Function Time	26-4*	Analog Out X42/7	35-46	Term. X48/2 Filter Time Constant
23-53	Energy Log	25-29	Destage Function	26-40	Terminal X42/7 Output	35-47	Term. X48/2 Live Zero
23-54	Reset Energy Log	25-30	Destage Function Time	26-41	Terminal X42/7 Min. Scale		
23-6*	Trending	25-4*	Staging Settings	26-42	Terminal X42/7 Max. Scale		
23-60	Trend Variable	25-40	Ramp Down Delay	26-43	Terminal X42/7 Bus Control		
23-61	Continuous Bin Data	25-41	Ramp Up Delay	26-44	Terminal X42/7 Timeout Preset		
23-62	Timed Bin Data	25-42	Staging Threshold	26-5*	Analog Out X42/9		
23-63	Timed Period Start	25-43	Destaging Threshold	26-50	Terminal X42/9 Output		
23-64	Timed Period Stop	25-44	Staging Speed [RPM]	26-51	Terminal X42/9 Min. Scale		
23-65	Minimum Bin Value	25-45	Staging Speed [Hz]	26-52	Terminal X42/9 Max. Scale		
23-66	Reset Continuous Bin Data	25-46	Destaging Speed [RPM]	26-53	Terminal X42/9 Bus Control		
23-67	Reset Timed Bin Data	25-47	Destaging Speed [Hz]	26-54	Terminal X42/9 Timeout Preset		
23-8*	Playback Counter	25-5*	Alternation Settings	26-6*	Analog Out X42/11		

Index

A

Abbreviations.....	71
AC input.....	12
AC mains.....	12
AC waveform.....	7, 12
Alarm.....	34
Alarm log.....	15
Alarms	
Log.....	46
AMA	
Configuring.....	19
T27 connected.....	23
T27 not connected.....	23
Warning.....	41
Analog signal.....	40
Analog speed reference.....	25
Application examples.....	23
Auto on.....	16, 21, 31, 33
Auto reset.....	15
Automatic motor adaptation.....	32
Automatic motor adaptation (AMA)	
Warning.....	44

B

Block diagram.....	12
Brake	
Control.....	41
Braking.....	32, 42

C

Circuit breakers.....	68
Control	
Card.....	40
Signal.....	19, 31
Terminal.....	16, 19, 31, 33
Word timeout.....	42
Control card	
Warning.....	45
Conventions.....	71, 72
Current	
DC.....	12
Limit.....	50
Output current.....	40
Rating.....	40

D

DC current.....	32
DC link.....	40
Default settings.....	21

Digital input.....	19, 33
Discharge time.....	5, 51
Disconnect switch.....	14
Disposal instruction.....	4
Drive module block diagram.....	12

E

Efficient parameter set-up for most applications.....	17
Encoder rotation.....	20
External	
Alarm reset.....	28
Command.....	12, 33
Interlock.....	72
Voltage.....	19

F

Fault	
Log.....	15
FC 102	
Specifications.....	54
FC 202	
Specifications.....	58
FC 302	
Specifications.....	63
Feedback.....	32
Fuses	
Recommended for CE compliance.....	69
Recommended for UL compliance.....	70
Replacement.....	70
Selection.....	68
Troubleshooting.....	48
Use of.....	68

G

General settings.....	19
Ground	
Warning.....	44
Grounding.....	14

H

Hand on.....	16, 31
Harmonic.....	12
Heat sink	
Warning.....	43
High voltage.....	5, 6, 14, 51

I

Indicator lights.....	16
Initialization.....	21

Input		Overheating.....	41
Power.....	14	Overtemperature.....	41
Terminal.....	14	Overvoltage.....	33, 50
Voltage.....	14		
Inputs		P	
Analog input.....	40	PELV.....	23, 28
Digital input.....	41	Phase loss.....	40
Input terminal.....	40	Potentiometer.....	26
Power.....	12, 48	Potentiometer reference.....	30
Signal.....	19	Power card	
Intermediate circuit.....	40	Warning.....	45
		Power factor.....	12
K		Power rating.....	54
KTY sensor.....	23	Programming.....	15, 18, 21, 40, 72
		Protection.....	68
L		Pulse start/stop.....	29
Leakage current (>3.5 mA).....	6		
Local control.....	15, 16, 31	Q	
Local control panel (LCP).....	15	Q1 my personal menu.....	16
		Q2 quick setup.....	17
M		Q5 changes made.....	17
Main menu.....	15	Qualified personnel.....	5, 51
Main menu mode.....	17	Quick menu.....	15, 17, 72
Mains			
Warning.....	43	R	
Mains voltage.....	32	Ramp-down time.....	50
Maintenance.....	31	Ramp-up time.....	50
Manual initialization.....	22	Ratings.....	54
MCT 10.....	18	Recycling.....	4
MCT 10 Set-up Software.....	18	Reference.....	19, 23, 32, 33
Mechanical brake control.....	25	Remote	
Menu keys.....	15	Programming.....	18
Menu structure.....	15, 16	Reference.....	32
Motor		Reset.....	15, 16, 22, 33, 34, 40, 41, 45
Current.....	12, 20	RMS current.....	12
Data.....	20, 50	RS485.....	24
data.....	41	Run command.....	21
Rotation.....	20	Run permissive.....	32
Thermal protection.....	28		
Thermistor.....	28	S	
		Safe Torque Off	
N		Warning.....	45
Navigation keys.....	15, 31	Safety.....	6
		Serial communication.....	16, 31, 32, 33, 34
O		Service.....	31
Open loop.....	19	Setpoint.....	33
Optional equipment.....	14	Set-up.....	15, 21
Output			
Current.....	32		
Terminal.....	14		
Overcurrent.....	33		

Short circuit.....	42
Short circuit current rating (SCCR).....	70
Sleep mode.....	33
Speed reference.....	19, 21, 25, 26, 32
Speed reference, analog.....	25
Start/stop.....	29
Start/stop command.....	27
Startup.....	22
Status mode.....	31
STO.....	23
Stop command.....	33
Supply voltage.....	14
Switching frequency.....	33
Symbols.....	71

T

Terminals	
Input.....	40
Programming example.....	19
Terminal 37.....	23
Terminal 53.....	19
Tightening.....	68
Thermistor.....	23
Torque	
Limit.....	41
Torque limit.....	50
Transient protection.....	12
Trip.....	28

U

Unintended motor rotation.....	6
Unintended start.....	5, 14

V

Voltage imbalance.....	40
Voltage reference via potentiometer.....	30

W

Warning.....	34
Windmilling.....	6



.....
Danfoss can accept no responsibility for possible errors in catalogues, brochures and other printed material. Danfoss reserves the right to alter its products without notice. This also applies to products already on order provided that such alterations can be made without subsequential changes being necessary in specifications already agreed. All trademarks in this material are property of the respective companies. Danfoss and the Danfoss logotype are trademarks of Danfoss A/S. All rights reserved.
.....

Danfoss A/S
Ulsnaes 1
DK-6300 Graasten
vlt-drives.danfoss.com

