



Operating Instructions

VLT[®] AutomationDrive FC 302 Low Harmonic Drive 132-630 kW



Contents

1 Introduction	5
1.1 Purpose of the Manual	5
1.2 Additional Resources	5
1.3 Product Overview	5
1.3.1 Intended Use	5
1.3.2 Working Principle	6
1.3.3 Exploded View Drawings	7
1.4 Enclosure Sizes and Power Ratings	15
1.5 Approvals and Certifications	15
1.5.1 Approvals	15
1.5.2 Compliance with ADN	15
1.6 Harmonics Overview	15
1.6.1 Harmonics	15
1.6.2 Harmonic Analysis	15
1.6.3 Effect of Harmonics in a Power Distribution System	16
1.6.4 IEC Harmonic Standards	17
1.6.5 IEEE Harmonic Standards	18
2 Safety	20
2.1 Safety	20
2.2 Qualified Personnel	20
2.3 Safety Precautions	20
3 Mechanical Installation	21
3.1 Installation Site Checklist	21
3.2 Unpacking	22
3.2.1 Items Supplied	22
3.3 Mounting	23
3.3.1 Cooling and Airflow	23
3.3.2 Lifting	24
3.3.3 Cable Entry and Anchoring	26
3.3.4 Terminal Locations for Enclosure Size D1n/D2n	30
3.3.5 Terminal Locations for Enclosure Size E9	32
3.3.6 Terminal Locations for Enclosure Size F18	33
3.3.7 Torque	35
4 Electrical Installation	36
4.1 Safety Instructions	36
4.2 Electromagnetic Compatibility (EMC)	37
4.2.1 EMC Interference	37

4.3 Power Connections	38
4.4 Grounding	38
4.5 Input Options	39
4.5.1 Extra Protection (RCD)	39
4.5.2 RFI Switch	39
4.5.3 Screened Cables	39
4.6 Motor Connection	39
4.6.1 Motor Cable	39
4.6.2 Brake Cable	40
4.6.3 Motor Insulation	40
4.6.4 Motor Bearing Currents	41
4.7 AC Mains Connection	41
4.7.1 Mains Connection	41
4.7.2 External Fan Supply	41
4.7.3 Power and Control Wiring for Unscreened Cables	42
4.7.4 Mains Disconnects	42
4.7.5 F-Frame Circuit Breakers	43
4.7.6 F-Frame Mains Contactors	43
4.8 Control Wiring	43
4.8.1 Control Cable Routing	43
4.8.2 Access to Control Terminals	45
4.8.3 Electrical Installation, Control Terminals	45
4.8.4 Electrical Installation, Control Cables	47
4.8.5 Safe Torque Off (STO)	49
4.9 Additional Connections	49
4.9.1 Serial Communication	49
4.9.2 Mechanical Brake Control	49
4.9.3 Parallel Connection of Motors	50
4.9.4 Motor Thermal Protection	50
4.9.5 Voltage/Current Input Selection (Switches)	50
4.10 Final Set-up and Test	51
4.11 F-frame Options	52
5 Commissioning	54
5.1 Safety Instructions	54
5.2 Applying Power	56
5.3 Local Control Panel Operation	56
5.3.1 Local Control Panel	56
5.3.2 LCP Layout	56
5.3.3 Parameter Settings	57
5.3.4 Uploading/Downloading Data to/from the LCP	58

5.3.5 Changing Parameter Settings	58
5.3.6 Restoring Default Settings	58
5.4 Basic Operational Programming	59
5.4.1 VLT® Low Harmonic Drive Programming	59
5.4.2 Commissioning with SmartStart	59
5.4.3 Commissioning via [Main Menu]	59
5.4.4 Asynchronous Motor Set-up	60
5.4.5 Permanent Magnet Motor Set-up	60
5.4.6 Automatic Energy Optimisation (AEO)	61
5.4.7 Automatic Motor Adaptation (AMA)	62
5.5 Checking Motor Rotation	62
5.6 Local Control Test	62
5.7 System Start-up	62
6 Application Examples	63
6.1 Introduction	63
6.2 Application Examples	63
7 Diagnostics and Troubleshooting	68
7.1 Status Messages	68
7.2 Warning and Alarm Types	68
7.2.1 Warnings	68
7.2.2 Alarm Trip	68
7.2.3 Alarm Trip-lock	68
7.3 Warnings and Alarm Definitions - Frequency Converter	68
7.4 Warnings and Alarm Definitions - Active Filter	77
7.5 Troubleshooting	82
8 Specifications	85
8.1 Power-Dependent Specifications	85
8.1.1 Mains Supply 3x380–480 V AC	85
8.1.2 Derating for Temperature	88
8.2 Mechanical Dimensions	90
8.3 General Technical Data	93
8.4 Fuses	98
8.4.1 Non-UL Compliance	99
8.4.2 Fuse Tables	99
8.4.3 Supplementary Fuses	100
8.5 General Torque Tightening Values	101
9 Appendix A - Parameters	102
9.1 Description of Parameters	102

9.2 Frequency Converter Parameter Lists	102
9.3 Active Filter Parameter Lists	108
10 Appendix B	115
10.1 Abbreviations and Conventions	115
Index	116

1 Introduction

1.1 Purpose of the Manual

The purpose of this manual is to provide information for the installation and operation of a VLT® AutomationDrive FC 302 Low Harmonic Drive. The manual includes relevant safety information for installation and operation.

Chapter 1 Introduction, chapter 2 Safety, chapter 3 Mechanical Installation, and chapter 4 Electrical Installation introduce the unit functions and cover proper mechanical and electrical installation procedures. There are chapters on start-up and commissioning, applications and basic troubleshooting. *Chapter 8 Specifications* provides a quick reference for ratings and dimensions, as well as other operating specifications. This manual provides a basic knowledge of the unit and explains set-up and basic operation.

VLT® is a registered trademark.

1.2 Additional Resources

Other resources are available to understand advanced functions and programming.

- The *VLT® AutomationDrive FC 302 Programming Guide* provides greater detail on working with parameters and many application examples.
- The *VLT® AutomationDrive FC 302 Design Guide* provides detailed capabilities and functionality to design motor control systems.
- Supplemental publications and manuals are available from Danfoss. See vlt-drives.danfoss.com/Support/Technical-Documentation/ for listings.
- Optional equipment may change some of the procedures described. Reference the instructions supplied with those options for specific requirements. Contact the local Danfoss supplier or visit the Danfoss website: vlt-drives.danfoss.com/Support/Technical-Documentation/ for downloads or additional information.
- The *VLT® Active Filter AAF 006 Operating Instructions* provide additional information about the filter portion of the low harmonic drive.

1.3 Product Overview

1.3.1 Intended Use

A frequency converter is an electronic motor controller that converts AC mains input into a variable AC waveform output. The frequency and voltage of the output are regulated to control the motor speed or torque. The frequency converter can vary the speed of the motor in response to system feedback, such as with position sensors on a conveyor belt. The frequency converter can also regulate the motor by responding to remote commands from external controllers.

The frequency converter:

- Monitors the system and motor status.
- Issues warnings or alarms for fault conditions.
- Starts and stops the motor.
- Optimises energy efficiency.

Operation and monitoring functions are available as status indications to an outside control system or serial communication network.

A low harmonic drive (LHD) is a single unit that combines the frequency converter with an advanced active filter (AAF) for harmonic mitigation. The frequency converter and filter are packaged together in an integrated system, but each functions independently. In this manual, there are separate specifications for the frequency converter and the filter. Since the frequency converter and filter are in the same enclosure, the unit is transported, installed, and operated as a single entity.

1

1.3.2 Working Principle

The low harmonic drive is a high-power frequency converter with an integrated active filter. An active filter is a device that actively monitors harmonic distortion levels and injects compensative harmonic current onto the line to cancel the harmonics.

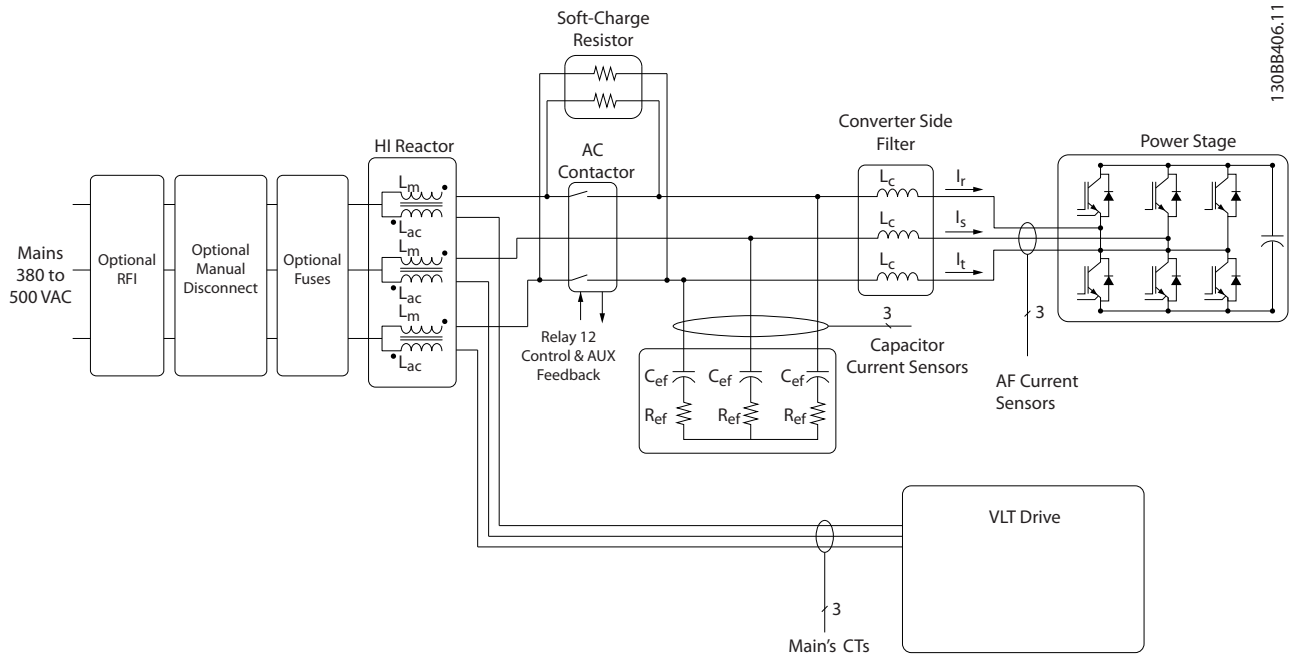
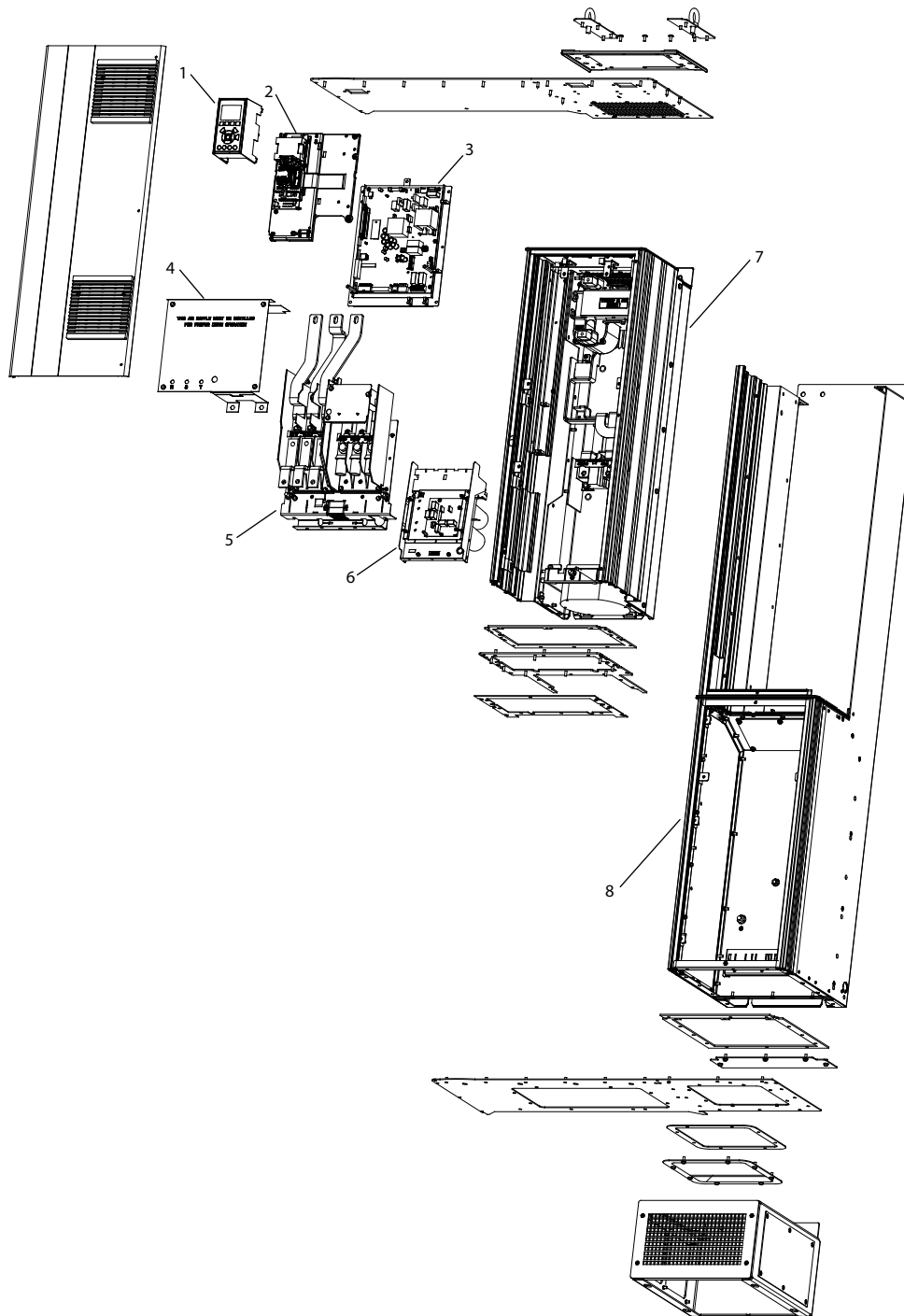

Illustration 1.1 Basic Layout for the Low Harmonic Drive

Low harmonic drives are designed to draw an ideal sinusoidal current waveform from the supply grid with a power factor of 1. Where traditional non-linear load draws pulse-shaped currents, the low harmonic drive compensates that via the parallel filter path, lowering the stress on the supply grid. The low harmonic drive meets the highest harmonic standards with a THDi less than 5% at full load for <3% pre-distortion on a 3% unbalanced 3-phase grid.

1.3.3 Exploded View Drawings



130BE136.10

1	Local control panel (LCP)	5	Input/output terminal assembly
2	Control card assembly	6	Capacitor bank assembly
3	Power card assembly	7	D1/D2 assembly
4	Terminal cover sheet	8	EOC assembly

Illustration 1.2 Enclosure Size D1n/D2n, Frequency Converter Enclosure

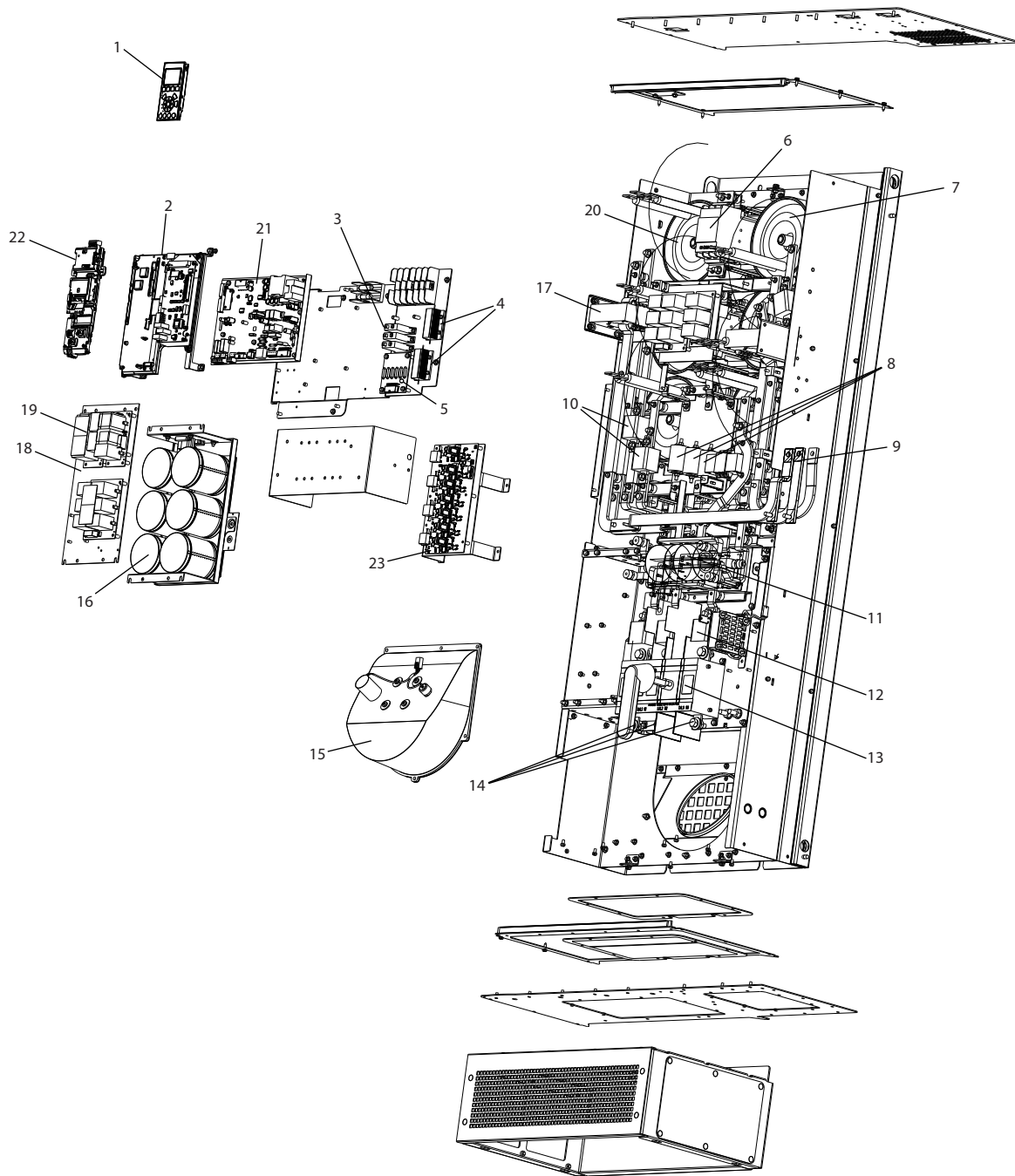

130BE110.10

1	Local control panel (LCP)	13	Mains fuses
2	Active filter card (AFC)	14	Mains disconnect
3	Metal oxide varistor (MOV)	15	Mains terminals
4	Soft charge resistors	16	Heat sink fan
5	AC capacitors discharge board	17	DC capacitor bank
6	Mains contactor	18	Current transformer
7	LC inductor	19	RFI differential mode filter
8	AC capacitors	20	RFI common mode filter
9	Mains bus bar to frequency converter input	21	HI inductor
10	IGBT fuses	22	Power card
11	RFI filter	23	Gate drive card
12	Fuses		

Illustration 1.3 Enclosure Size D1n/D2n, Filter Enclosure

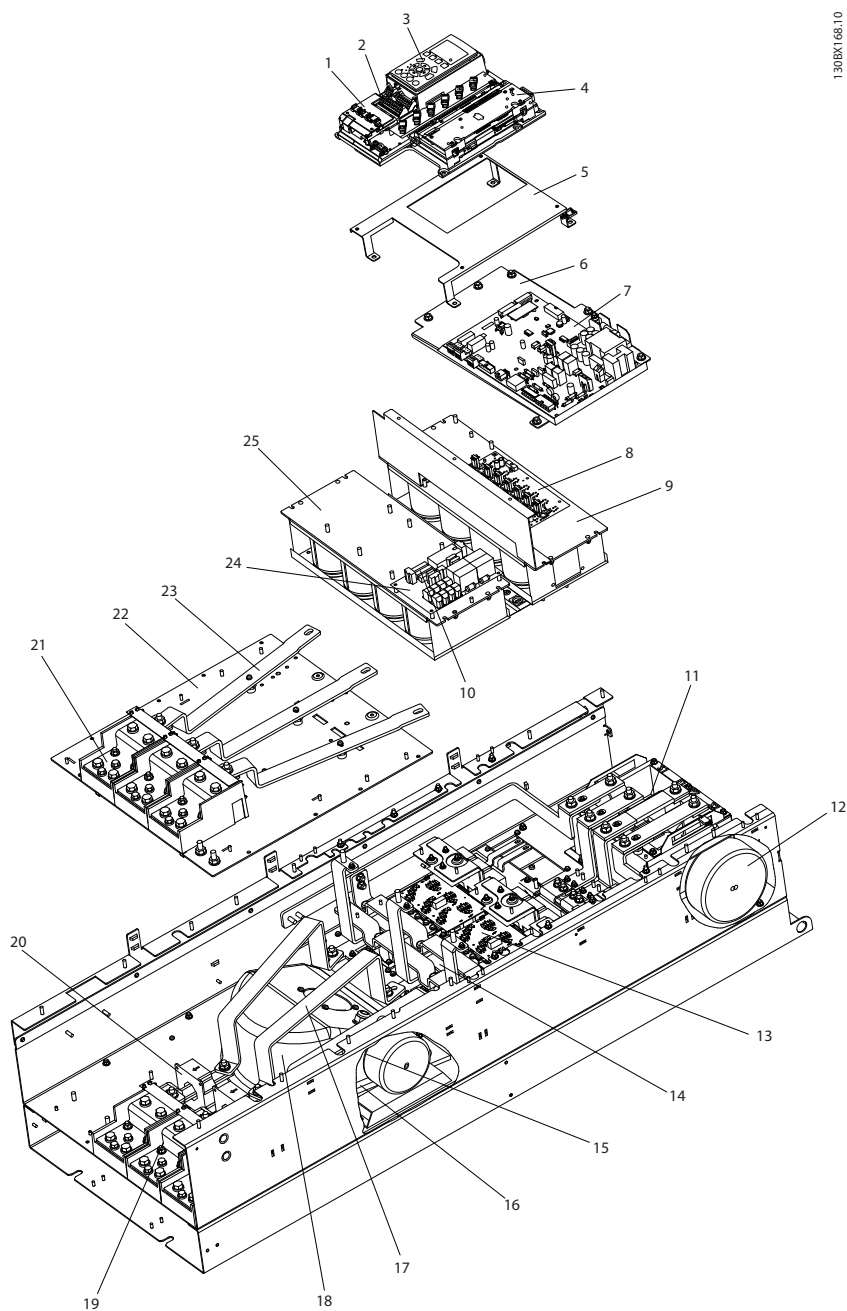

1-30BX168.10

1	Control card	14	SCR and diode
2	Control input terminals	15	Fan inductor (not on all units)
3	Local control panel (LCP)	16	Soft charge resistor assembly
4	Control card C option	17	IGBT output bus bar
5	Mounting bracket	18	Fan assembly
6	Power card mounting plate	19	Output motor terminals
7	Power card	20	Current sensor
8	IGBT gate drive card	21	Mains AC power input terminals
9	Upper capacitor bank assembly	22	Input terminal mounting plate
10	Soft charge fuses	23	AC input bus bar
11	DC inductor	24	Soft charge card
12	Fan transformer	25	Lower capacitor bank assembly
13	IGBT module		

Illustration 1.4 Enclosure Size E9, Frequency Converter Enclosure

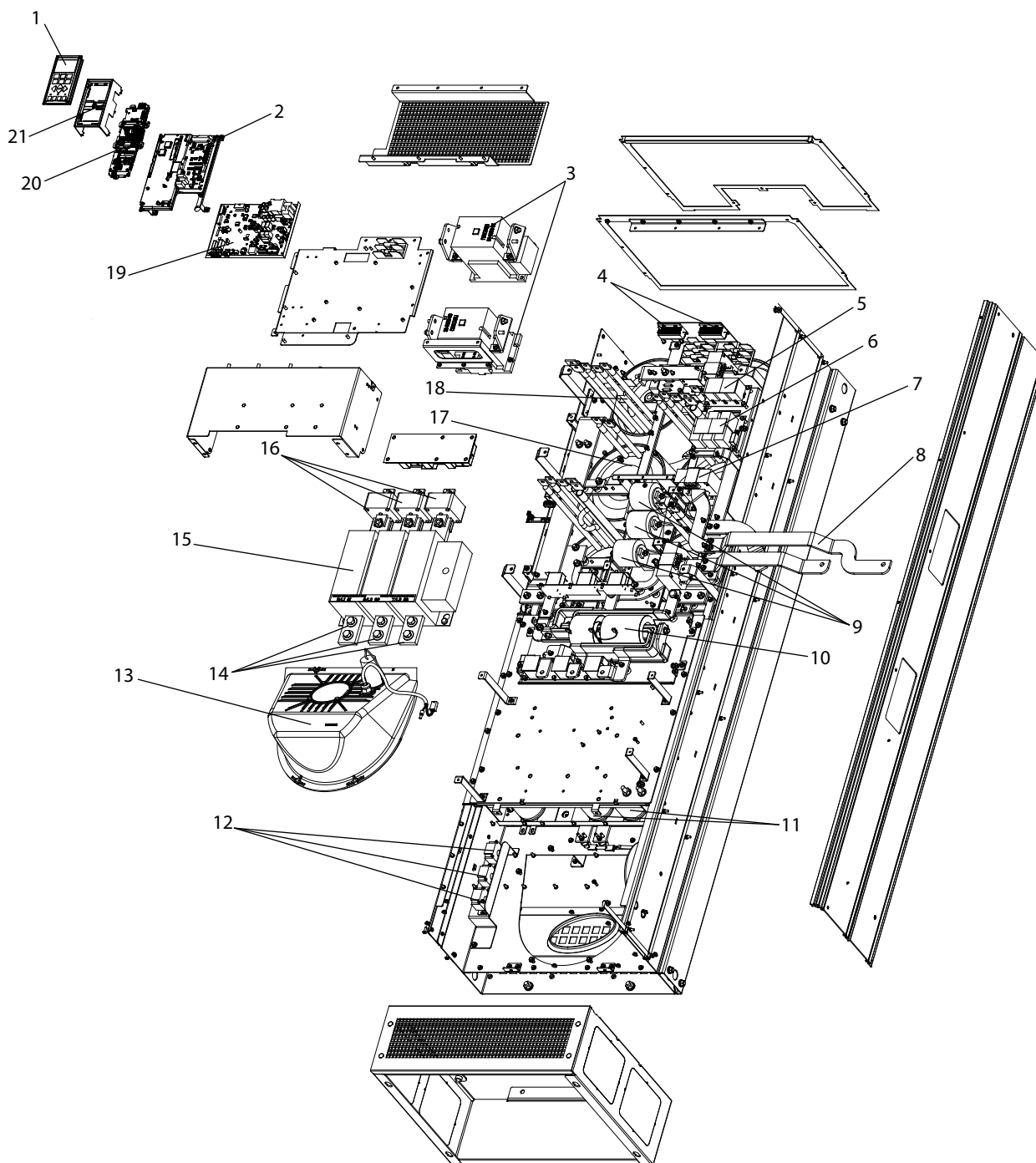

1	Local control panel (LCP)	12	AC capacitor current transducers
2	Active filter card (AFC)	13	Heat sink fan
3	Mains contactors	14	Mains terminals
4	Soft charge resistors	15	Mains disconnect
5	RFI differential mode filter	16	Mains fuses
6	RFI common mode filter	17	LC inductor
7	Current transformer (CT)	18	HI inductor
8	Mains bus bars to drive output	19	Power card
9	AC capacitors	20	Control card
10	RFI	21	LCP cradle
11	Lower DC capacitor bank		

Illustration 1.5 Enclosure Size E9, Filter Enclosure

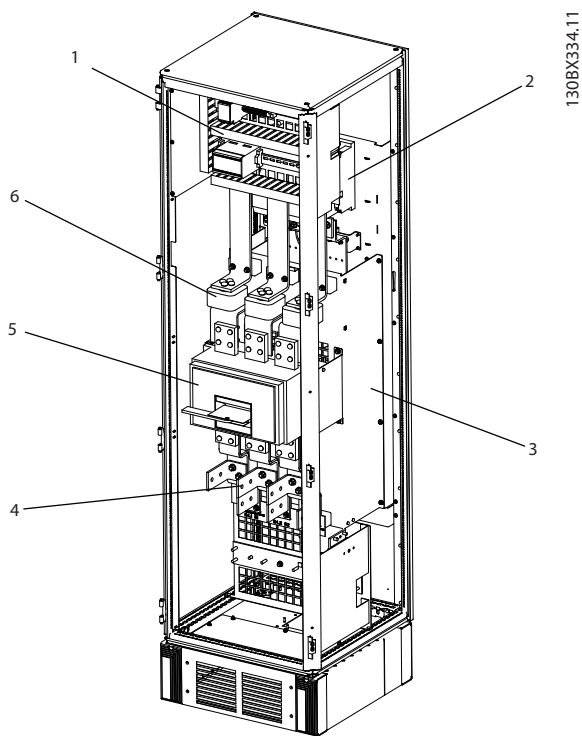

1	Contactor	4	Circuit breaker or disconnect (if purchased)
2	RFI filter	5	AC mains/line fuses (if purchased)
3	Mains AC power input terminals	6	Mains disconnect

Illustration 1.6 Enclosure Size F18, Input Options Cabinet

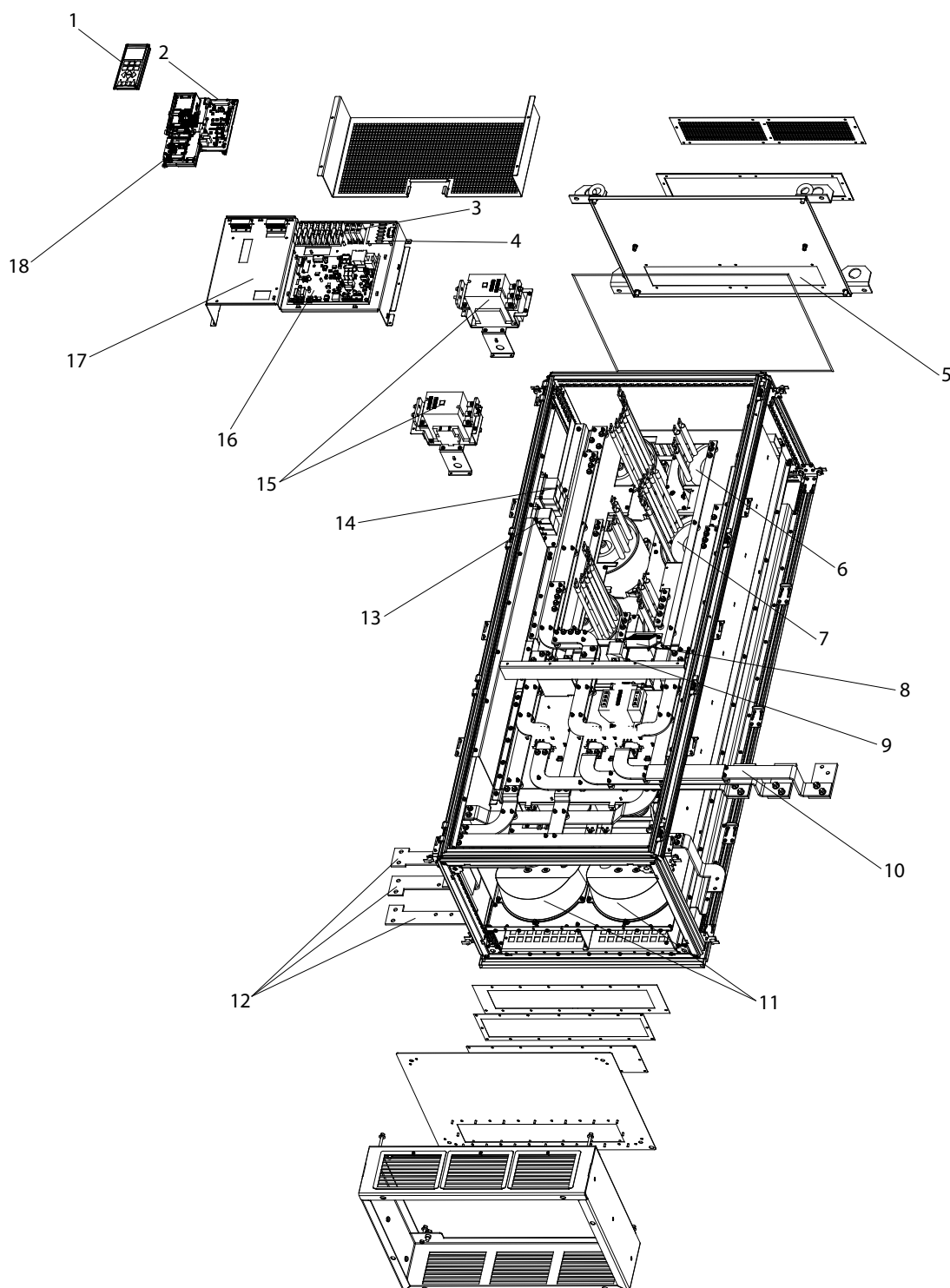

1	Local control panel (LCP)	10	Mains bus bars to frequency converter input
2	Active filter card (AFC)	11	Heat sink fans
3	Soft charge resistors	12	Mains terminals (R/L1, S/L2, T/L3) from options cabinet
4	Metal oxide varistor (MOV)	13	RFI differential mode filter
5	AC capacitors discharge board	14	RFI common mode filter
6	LC inductor	15	Mains contactor
7	HI inductor	16	Power card
8	Mixing fan	17	Control card
9	IGBT fuses	18	LCP cradle

Illustration 1.7 Enclosure Size F18, Filter Cabinet

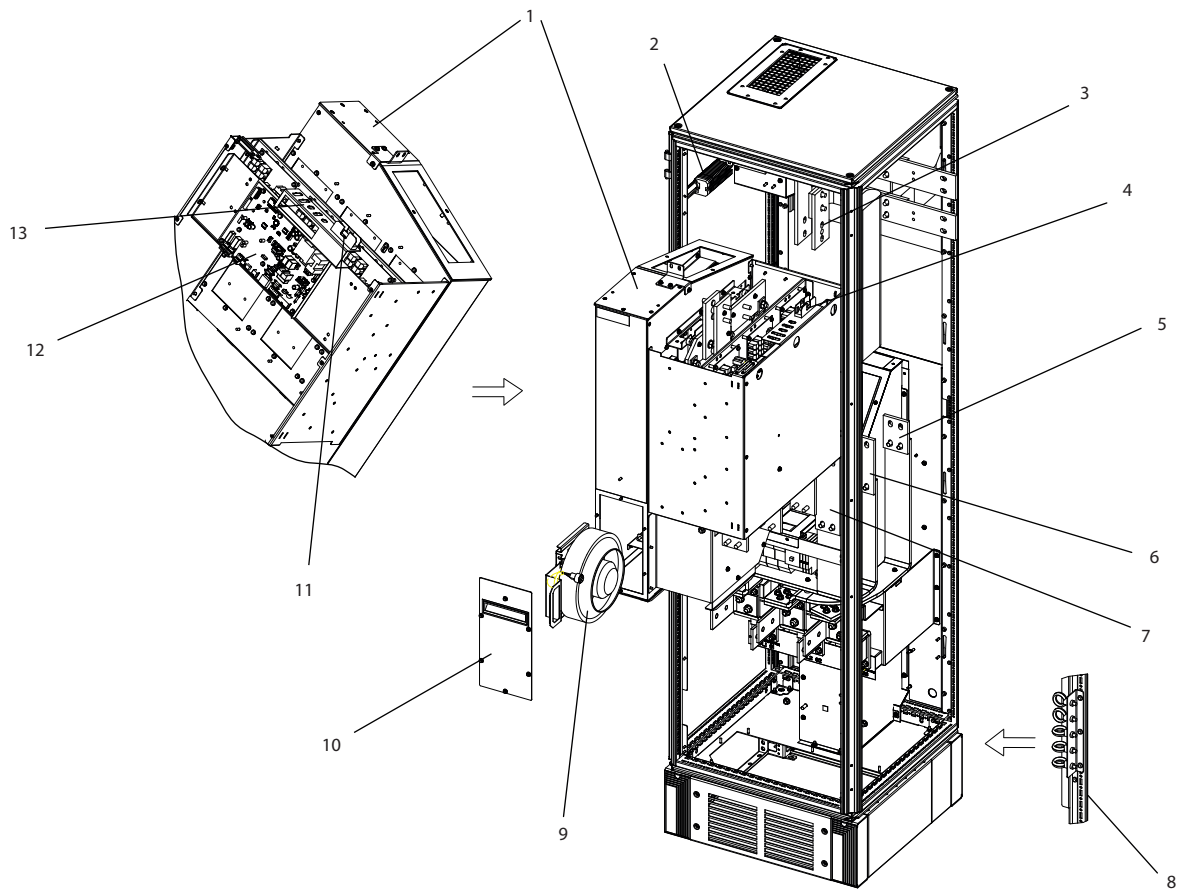

1	Rectifier module	8	Module heat sink fan
2	DC bus bar	9	Fan door cover
3	SMPS fuse	10	SMPS fuse
4	(Optional) back AC fuse mounting bracket	11	Power card
5	(Optional) middle AC fuse mounting bracket	12	Panel connectors
6	(Optional) front AC fuse mounting bracket	13	Control card
7	Module lifting eye bolts (mounted on a vertical strut)		

Illustration 1.8 Enclosure Size F18, Rectifier Cabinet

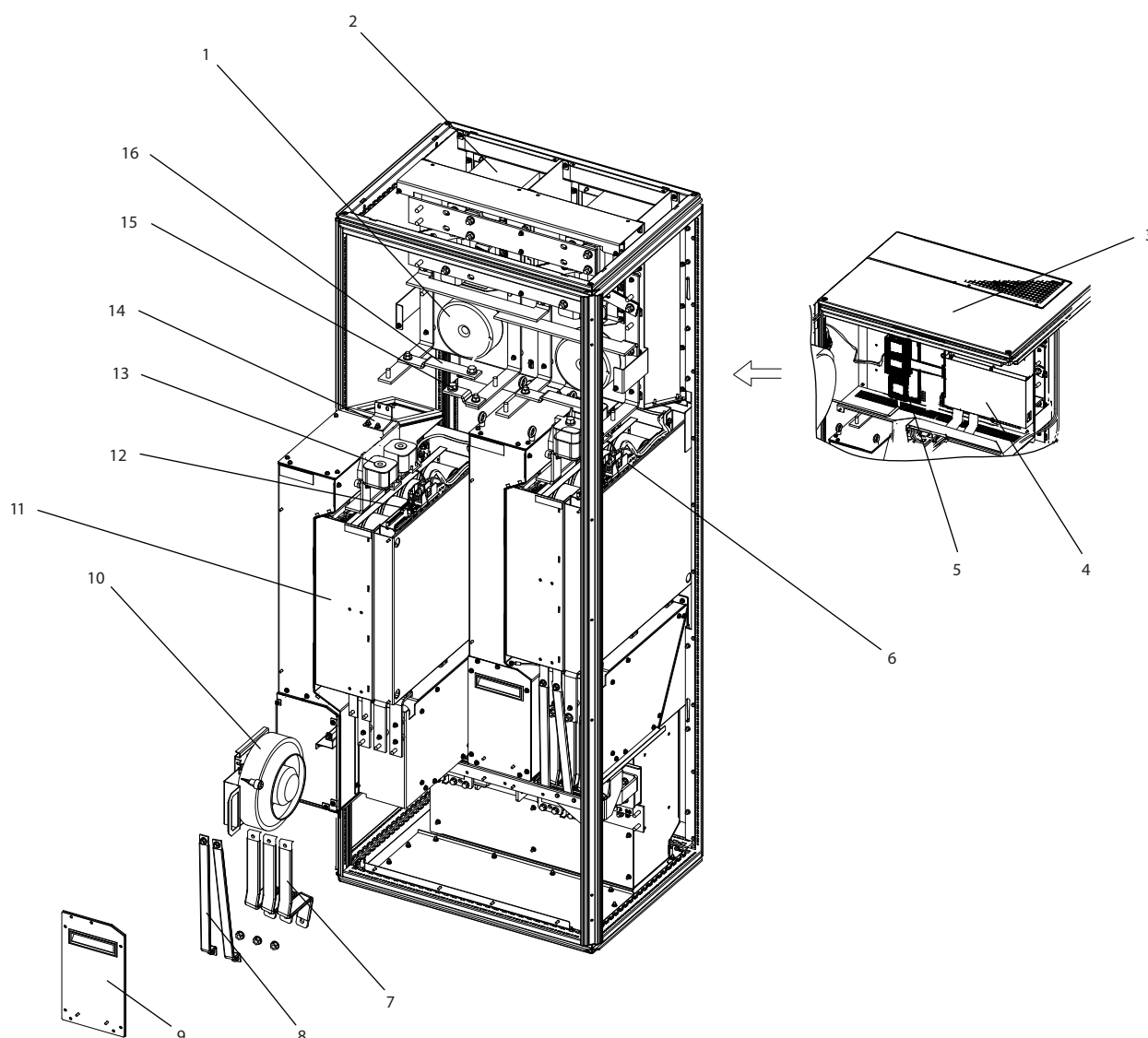

1	Fan transformer	9	Fan door cover
2	DC-link inductor	10	Module heat sink fan
3	Top cover plate	11	Inverter module
4	MDCIC board	12	Panel connectors
5	Control card	13	DC fuse
6	SMPS fuse and fan fuse	14	Mounting bracket
7	Motor output bus bar	15	(+) DC bus bar
8	Brake output bus bar	16	(-) DC bus bar

Illustration 1.9 Enclosure Size F18, Inverter Cabinet

1.4 Enclosure Sizes and Power Ratings

Enclosure size		D1n	D2n	E9	F18
Enclosure protection	IP	21/54	21/54	21/54	21/54
	NEMA	Type 1/Type 12	Type 1/Type 12	Type 1/Type 12	Type 1/Type 12
Frequency converter dimensions [mm/inch]	Height	1740/68.5	1740/68.5	2000.7/78.77	2278.4/89.70
	Width	915/36.02	1020/40.16	1200/47.24	2792/109.92
	Depth	380/14.96	380/14.96	493.5/19.43	605.8/23.85
Frequency converter weights [kg/lbs]	Maximum weight	353/777	413/910	676/1490	1900/4189
	Shipping weight	416/917	476/1050	840/1851	2345/5171

Table 1.1 Mechanical Dimensions, Enclosure Sizes D, E, and F

1.5 Approvals and Certifications

1.5.1 Approvals

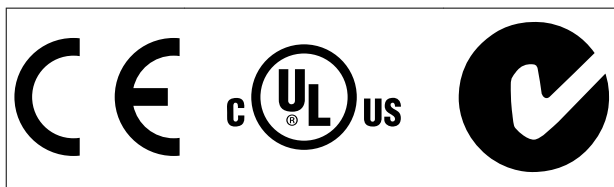

Table 1.2 Compliance Marks: CE, UL, and C-Tick

1.5.2 Compliance with ADN

For compliance with the European Agreement concerning International Carriage of Dangerous Goods by Inland Waterways (ADN), refer to *ADN-compliant Installation* in the *Design Guide*.

1.6 Harmonics Overview

1.6.1 Harmonics

Non-linear loads such as found with 6-pulse frequency converters do not draw current uniformly from the power line. This non-sinusoidal current has components which are multiples of the fundamental current frequency. These components are referred to as harmonics. It is important to control the total harmonic distortion on the mains supply. Although the harmonic currents do not directly affect electrical energy consumption, they generate heat in wiring and transformers and can impact other devices on the same power line.

1.6.2 Harmonic Analysis

Since harmonics increase heat losses, it is important to design systems with harmonics in mind to prevent overloading the transformer, inductors, and wiring.

When necessary, perform an analysis of the system harmonics to determine equipment effects.

A non-sinusoidal current is transformed with a Fourier series analysis into sine-wave currents at different frequencies, that is, different harmonic currents I_n with 50 Hz or 60 Hz as the fundamental frequency.

Abbreviation	Description
f_1	Fundamental frequency (50 Hz or 60 Hz)
I_1	Current at the fundamental frequency
U_1	Voltage at the fundamental frequency
I_n	Current at the n^{th} harmonic frequency
U_n	Voltage at the n^{th} harmonic frequency
n	Harmonic order

Table 1.3 Harmonics-related Abbreviations

	Fundamental current (I_1)	Harmonic current (I_n)		
Current	I_1	I_5	I_7	I_{11}
Frequency [Hz]	50	250	350	550

Table 1.4 Fundamental and Harmonic Currents

Current	Harmonic current				
	I_{RMS}	I_1	I_5	I_7	I_{11-49}
Input current	1.0	0.9	0.5	0.2	< 0.1

Table 1.5 Harmonic Currents Compared to the RMS Input Current

The voltage distortion on the mains supply voltage depends on the size of the harmonic currents multiplied

by the mains impedance for the frequency in question. The total voltage distortion (THDi) is calculated based on the individual voltage harmonics using this formula:

$$THDi = \frac{\sqrt{U_{25}^2 + U_{27}^2 + \dots + U_{2n}^2}}{U}$$

1.6.3 Effect of Harmonics in a Power Distribution System

In *Illustration 1.10*, a transformer is connected on the primary side to a point of common coupling PCC1, on the medium voltage supply. The transformer has an impedance Z_{xfr} and feeds a number of loads. The point of common coupling where all loads are connected is PCC2. Each load is connected through cables that have an impedance Z_1 , Z_2 , Z_3 .

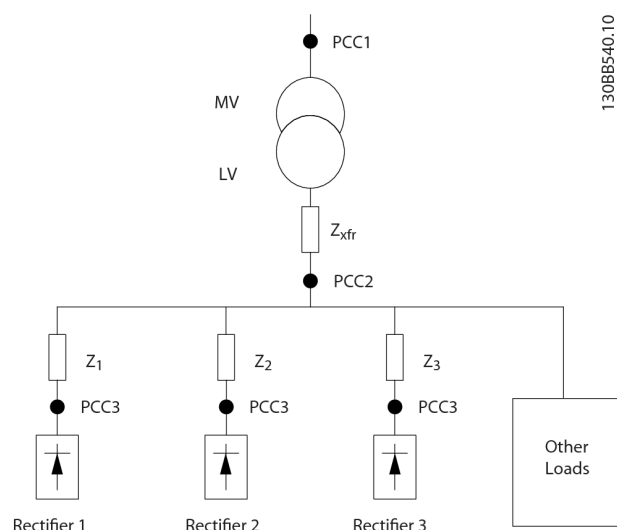

PCC	Point of common coupling
MV	Medium voltage
LV	Low voltage
Z_{xfr}	Transformer impedance
$Z_{\#}$	Modeling resistance and inductance in the wiring

Illustration 1.10 Small Distribution System

Harmonic currents drawn by non-linear loads cause distortion of the voltage because of the voltage drop on the impedances of the distribution system. Higher impedances result in higher levels of voltage distortion.

Current distortion relates to apparatus performance and it relates to the individual load. Voltage distortion relates to system performance. It is not possible to determine the voltage distortion in the PCC knowing only the harmonic performance of the load. To predict the distortion in the

PCC, the configuration of the distribution system and relevant impedances must be known.

A commonly used term for describing the impedance of a grid is the short-circuit ratio R_{sce} . R_{sce} is defined as the ratio between the short circuit apparent power of the supply at the PCC (S_{sc}) and the rated apparent power of the load (S_{equ}).

$$R_{sce} = \frac{S_{sc}}{S_{equ}}$$

where $S_{sc} = \frac{U^2}{Z_{supply}}$ and $S_{equ} = U \times I_{equ}$

Negative effects of harmonics

- Harmonic currents contribute to system losses (in cabling, and transformer).
- Harmonic voltage distortion causes disturbance to other loads and increases losses in other loads.

1.6.4 IEC Harmonic Standards

The mains voltage is rarely a uniform sinusoidal voltage with constant amplitude and frequency because loads that draw non-sinusoidal currents from the mains have non-linear characteristics.

Harmonics and voltage fluctuations are 2 forms of low-frequency mains interference. They have a different appearance at their origin than at any other point in the mains system when a load is connected. So, a range of influences must be determined collectively when assessing the effects of mains interference. These influences include the mains feed, structure, and loads.

Mains interference can cause the following:

Undervoltage warnings

- Incorrect voltage measurements due to distortion of the sinusoidal mains voltage.
- Cause incorrect power measurements because only RMS-true measuring takes harmonic content into account.

Higher functional losses

- Harmonics reduce the active power, apparent power, and reactive power.
- Distort electrical loads resulting in audible interference in other devices, or in worst case, even destruction.
- Shorten the lifetime of devices as a result of heating.

In most of Europe, the basis for the objective assessment of the quality of mains power is the Electromagnetic Compatibility of Devices Act (EMVG). Compliance with these regulations ensures that all devices and networks connected to electrical distribution systems fulfil their intended purpose without generating problems.

Standard	Definition
EN 61000-2-2, EN 61000-2-4, EN 50160	Define the mains voltage limits required for public and industrial power grids.
EN 61000-3-2, 61000-3-12	Regulate mains interference generated by connected devices in lower current products.
EN 50178	Monitors electronic equipment for use in power installations.

Table 1.6 EN Design Standards for Mains Power Quality

There are 2 European standards that address harmonics in the frequency range from 0 Hz to 9 kHz:

EN 61000-2-2 (Compatibility Levels for Low-Frequency Conducted Disturbances and Signalling in Public Low-Voltage Power Supply Systems) states the requirements for compatibility levels for PCC (point of common coupling) of low-voltage AC systems on a public supply network. Limits are specified only for harmonic voltage and total harmonic distortion of the voltage. EN 61000-2-2 does not define limits for harmonic currents. In situations where the total harmonic distortion $THD(V)=8\%$, PCC limits are identical to those limits specified in the EN 61000-2-4 Class 2.

EN 61000-2-4 (Compatibility Levels for Low-Frequency Conducted Disturbances and Signalling in Industrial Plants) states the requirements for compatibility levels in industrial and private networks. The standard further defines the following 3 classes of electromagnetic environments:

- Class 1 relates to compatibility levels that are less than the public supply network, which affects equipment sensitive to disturbances (lab equipment, some automation equipment, and certain protection devices).
- Class 2 relates to compatibility levels that are equal to the public supply network. The class applies to PCCs on the public supply network and to IPCs (internal points of coupling) on industrial or other private supply networks. Any equipment designed for operation on a public supply network is allowed in this class.
- Class 3 relates to compatibility levels greater than the public supply network. This class applies only to IPCs in industrial environments. Use this class where the following equipment is found:

- Large converters.
- Welding machines.
- Large motors starting frequently.
- Loads that change quickly.

Typically, a class cannot be defined ahead of time without taking into account the intended equipment and processes to be used in the environment. VLT® AutomationDrive FC 302 Low Harmonic Drive observes the limits of Class 3 under typical supply system conditions ($R_{SC} > 10$ or $V_{k \text{ Line}} < 10\%$).

Harmonic order (h)	Class 1 ($V_h\%$)	Class 2 ($V_h\%$)	Class 3 ($V_h\%$)
5	3	6	8
7	3	5	7
11	3	3.5	5
13	3	3	4.5
17	2	2	4
$17 < h \leq 49$	$2.27 \times (17/h) - 0.27$	$2.27 \times (17/h) - 0.27$	$4.5 \times (17/h) - 0.5$

Table 1.7 Compatibility Levels for Harmonics

	Class 1	Class 2	Class 3
THD(V)	5%	8%	10%

Table 1.8 Compatibility Levels for the Total Harmonic Voltage Distortion THD(V)

1.6.5 IEEE Harmonic Standards

The IEEE 519 standard (Recommended Practices and Requirements for Harmonic Control in Electrical Power Systems) provides specific limits for harmonic voltages and currents for individual components within the supply network. The standard also provides limits for the sum of all loads at the point of common coupling (PCC).

To determine permissible harmonic voltage levels, IEEE 519 uses a ratio between the supply short-circuit current and the maximum current of the individual load. For permissible harmonic voltage levels for individual loads, see *Table 1.9*. For permissible levels for all loads connected to the PCC, see *Table 1.10*.

I_{sc}/I_L (R_{SCE})	Permissible individual harmonic voltages	Typical areas
10	2.5–3%	Weak grid
20	2.0–2.5%	1–2 large loads
50	1.0–1.5%	A few high-output loads
100	0.5–1%	5–20 medium-output loads
1000	0.05–0.1%	Strong grid

Table 1.9 Permissible Voltage THD at the PCC for Each Individual Load

Voltage at the PCC	Permissible individual harmonic voltages	Permissible THD(V)
$V_{Line} \leq 69$ kV	3%	5%

Table 1.10 Permissible Voltage THD at the PCC for all Loads

Limit harmonic currents to specified levels, as shown in *Table 1.11*. IEEE 519 utilises a ratio between the supply short-circuit current and the maximum current consumption at the PCC, averaged over 15 minutes or 30 minutes. In certain instances when dealing with harmonic limits containing low harmonic numbers, the IEEE 519 limits are lower than the 61000-2-4 limits. Low harmonic drives observe the total harmonic distortion as defined in IEEE 519 for all R_{SCE} . Each individual harmonic current fulfills table 10–3 in IEEE 519 for $R_{SCE} \geq 20$.

I _{sc} /I _L (R _{sce})	h<11	11≤h<17	17≤h<23	23≤h<35	35≤h	Total demand distortion TDD
<20	4%	2.0%	1.5%	0.6%	0.3%	5%
20<50	7%	3.5%	2.5%	1.0%	0.5%	8%
50<100	10%	4.5%	4.0%	1.5%	0.7%	12%
100<1000	12%	5.5%	5.0%	2.0%	1.0%	15%
>1000	15%	7.0%	6.0%	2.5%	1.4%	20%

Table 1.11 Permissible Harmonic Currents at the PCC

The VLT[®] AutomationDrive FC 302 Low Harmonic Drive complies with the following standards:

- IEC61000-2-4
- IEC61000-3-4
- IEEE 519
- G5/4

2 Safety

2

2.1 Safety

The following symbols are used in this document:



Indicates a potentially hazardous situation which could result in death or serious injury.



Indicates a potentially hazardous situation which could result in minor or moderate injury. It may also be used to alert against unsafe practices.

NOTICE

Indicates important information, including situations that may result in damage to equipment or property.

2.2 Qualified Personnel

Correct and reliable transport, storage, installation, operation and maintenance are required for the safe operation of the frequency converter. Only qualified personnel are allowed to install or operate this equipment.

Qualified personnel is defined as trained staff, who are authorised to install, commission, and maintain equipment, systems and circuits in accordance with pertinent laws and regulations. Additionally, qualified personnel are familiar with the instructions and safety measures described in this document.

2.3 Safety Precautions



HIGH VOLTAGE

Frequency converters contain high voltage when connected to AC mains input power. Qualified personnel only should perform installation, start up, and maintenance. Failure to perform installation, start up, and maintenance by qualified personnel could result in death or serious injury.



UNINTENDED START

When the frequency converter is connected to AC mains, the motor may start at any time. The frequency converter, motor, and any driven equipment must be in operational readiness. Failure to be in operational readiness when the frequency converter is connected to AC mains could result in death, serious injury, equipment, or property damage.



DISCHARGE TIME

Frequency converters contain DC-link capacitors that can remain charged even when the frequency converter is not powered. To avoid electrical hazards, disconnect AC mains, any permanent magnet type motors, and any remote DC-link power supplies, including battery back-ups, UPS, and DC-link connections to other frequency converters. Wait for the capacitors to fully discharge before performing any service or repair work. The amount of wait time is listed in the *Discharge Time* table. Failure to wait the specified time after power has been removed before doing service or repair could result in death or serious injury.

Voltage [V]	Power range [kW]	Minimum waiting time (minutes)
380-500	132-200 kW	20
	250-630 kW	40

Table 2.1 Discharge Times

3 Mechanical Installation

3.1 Installation Site Checklist

3.1.1 Planning the Installation Site

CAUTION

It is important to plan the installation of the frequency converter. Neglecting to plan may result in extra work during and after installation.

Select the best possible operation site by considering the following:

- Ambient operating temperature.
- Installation method.
- How to cool the unit.
- Position of the frequency converter.
- Cable routing.
- Ensure that the power source supplies the correct voltage and necessary current.
- Ensure that the motor current rating is within the maximum current from the frequency converter.
- If the frequency converter is without built-in fuses, ensure that the external fuses are rated correctly.

3.1.2 Equipment Pre-Installation Checklist

- Before unpacking the frequency converter, examine the packaging for signs of damage. If the unit is damaged, refuse delivery, and immediately contact the shipping company to claim the damage.
- Before unpacking the frequency converter, locate it as close as possible to the final installation site.
- Compare the model number on the nameplate to what was ordered to verify the proper equipment.
- Ensure that each of the following are rated for the same voltage:
 - Mains (power)
 - Frequency converter
 - Motor
- Ensure that the output current rating is equal to or greater than the motor full load current for peak motor performance.

- Motor size and frequency converter power must match for proper overload protection.
- If frequency converter rating is less than that of the motor, full motor output is impossible.

3.2 Unpacking

3.2.1 Items Supplied

Items supplied may vary according to product configuration.

- Make sure that the items supplied and the information on the nameplate correspond to the order confirmation.
- Check the packaging and the frequency converter visually for damage caused by inappropriate handling during shipment. File any claim for damage with the carrier. Retain damaged parts for clarification.

3

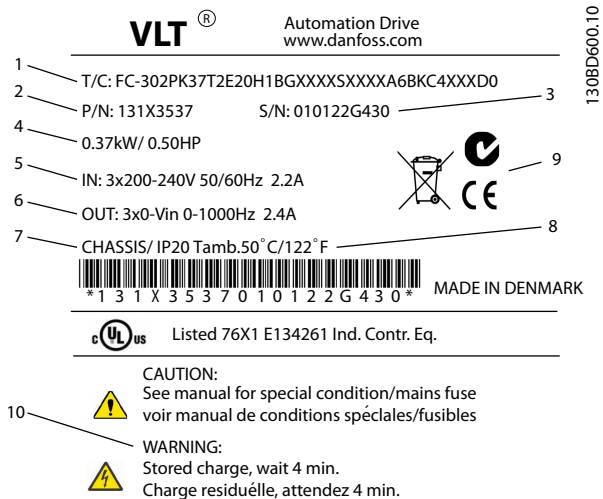

1	Type code
2	Order number
3	Serial number
4	Power rating
5	Input voltage, frequency and current (at low/high voltages)
6	Output voltage, frequency and current (at low/high voltages)
7	Enclosure type and IP rating
8	Maximum ambient temperature
9	Certifications
10	Discharge time (Warning)

Illustration 3.1 Product Nameplate (Example)

NOTICE

Do not remove the nameplate from the frequency converter (loss of warranty).

3.3 Mounting

3.3.1 Cooling and Airflow

Cooling

Obtain cooling by taking air in through the plinth in the front and out of the top, in and out the back of the unit, or by combining the cooling possibilities.

Back cooling

The backchannel air can also be ventilated in and out the back. This offers a solution where the backchannel could take air from outside the facility and return the heat losses outside the facility thus reducing air-conditioning requirements.

Airflow

Secure the necessary airflow over the heat sink. The flow rate is shown in *Table 3.1*.

Enclosure protection	Enclosure size	Door fan/top fan airflow Total airflow of multiple fans	Heat sink fan Total airflow for multiple fans
IP21/NEMA 1 IP54/NEMA 12	D1n	3 door fans, 442 m ³ /h 2+1=2x170+102	2 heat sink fans, 1185 m ³ /h (1+1=765+544)
	D2n	3 door fan, 544 m ³ /h 2+1=2x170+204	2 heat sink fans, 1605 m ³ /h (1+1=765+840)
	E9	4 door fans, 680 m ³ /h (400 cfm) (2+2, 4x170=680)	2 heat sink fans, 2675 m ³ /h (1574 cfm) (1+1, 1230+1445=2675)
	F18	6 door fans, 3150 m ³ /h (1854 cfm) (6x525=3150)	5 heat sink fans, 4485 m ³ /h (2639 cfm) 2+1+2, ((2x765)+(3x985)=4485)

Table 3.1 Heat Sink Air Flow

NOTICE

For the frequency converter section, the fan runs for the following reasons:

- AMA.
- DC hold.
- Pre-mag.
- DC brake.
- 60% of nominal current is exceeded.
- Specific heat sink temperature exceeded (power size dependent).
- Specific power card ambient temperature exceeded (power size dependent).
- Specific control card ambient temperature exceeded.

Once the fan is started, it runs for minimum 10 minutes.

NOTICE

For the active filter, the fan runs for the following reasons:

- Active filter running.
- Active filter not running, but mains current exceeding the limit (power size dependent).
- Specific heat sink temperature exceeded (power size dependent).
- Specific power card ambient temperature exceeded (power size dependent).
- Specific control card ambient temperature exceeded.

Once the fan is started, it runs for minimum 10 minutes.

External ducts

If additional duct work is added externally to the Rittal cabinet, calculate the pressure drop in the ducting. Use *Illustration 3.2*, *Illustration 3.3*, and *Illustration 3.4* to derate the frequency converter according to the pressure drop.

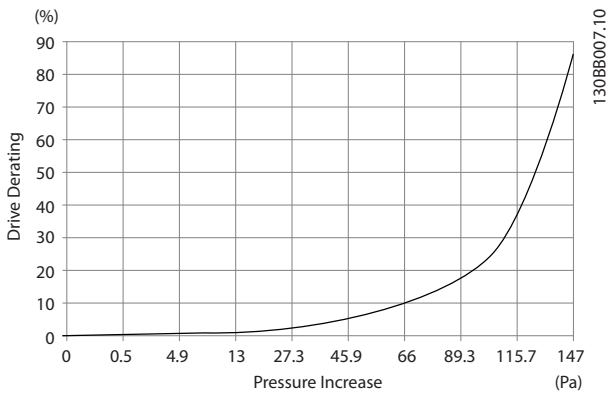

Illustration 3.2 D-Enclosure Derating vs. Pressure Change
Frequency Converter Air Flow: 450 cfm (765 m³/h)

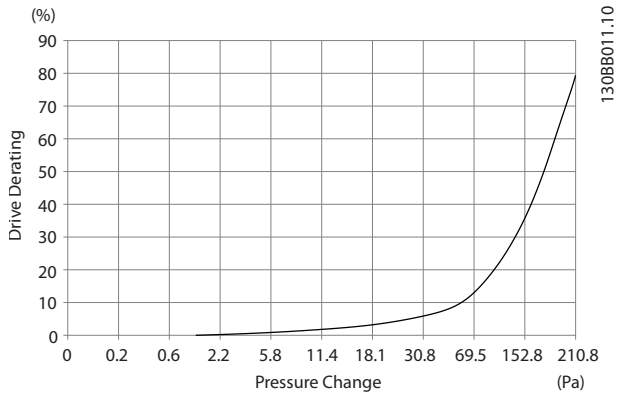

Illustration 3.3 E-Enclosure Derating vs. Pressure Change
Frequency Converter Air Flow: 850 cfm (1445 m³/h)

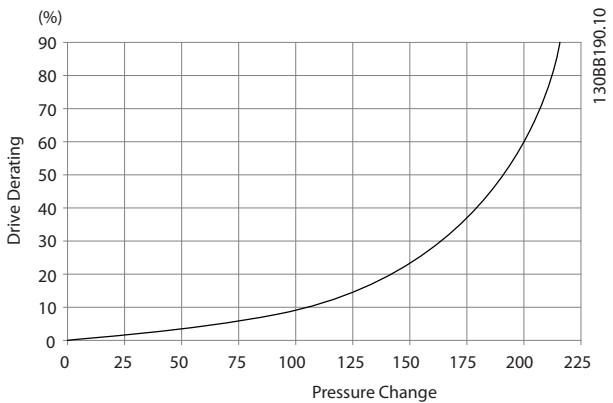
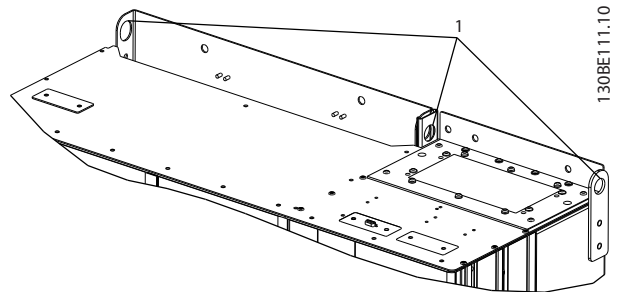

Illustration 3.4 F-Enclosure Derating vs. Pressure Change
Frequency Converter Air Flow: 580 cfm (985 m³/h)

3.3.2 Lifting

Lift the frequency converter using the dedicated lifting eyes. For all D-frames, use a bar to avoid bending the lifting holes of the frequency converter.



1 Lifting holes

Illustration 3.5 Recommended Lifting Method, Enclosure Size D1n/D2n

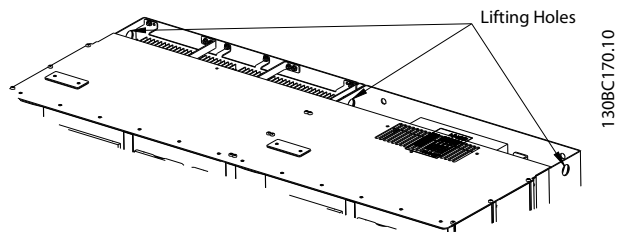
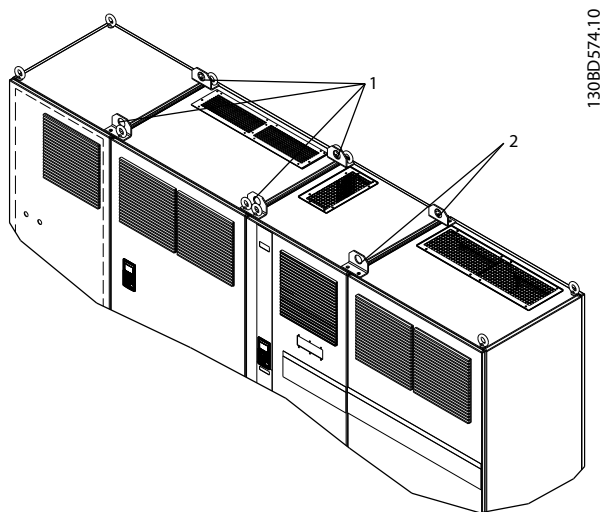

Illustration 3.6 Recommended Lifting Method, Enclosure Size E9

⚠ WARNING

The lifting bar must be able to handle the weight of the frequency converter. See *chapter 8.2 Mechanical Dimensions* for the weight of the different enclosure sizes. Maximum diameter for bar is 2.5 cm (1 inch). The angle from the top of the frequency converter to the lifting cable should be 60° or greater.



1	Lifting holes for the filter
2	Lifting holes for the frequency converter

Illustration 3.7 Recommended Lifting Method, Enclosure Size F18

NOTICE

A spreader bar is also an acceptable way to lift the F-frame.

NOTICE

The F18 pedestal is packaged separately and included in the shipment. Mount the frequency converter on the pedestal in its final location. The pedestal allows proper airflow and cooling.

3.3.3 Cable Entry and Anchoring

Cables enter the unit through gland plate openings in the bottom. *Illustration 3.8*, *Illustration 3.9*, *Illustration 3.10*, and *Illustration 3.11* show gland entry locations and detailed views of anchoring hole dimensions.

3

Bottom View, D1n/D2n

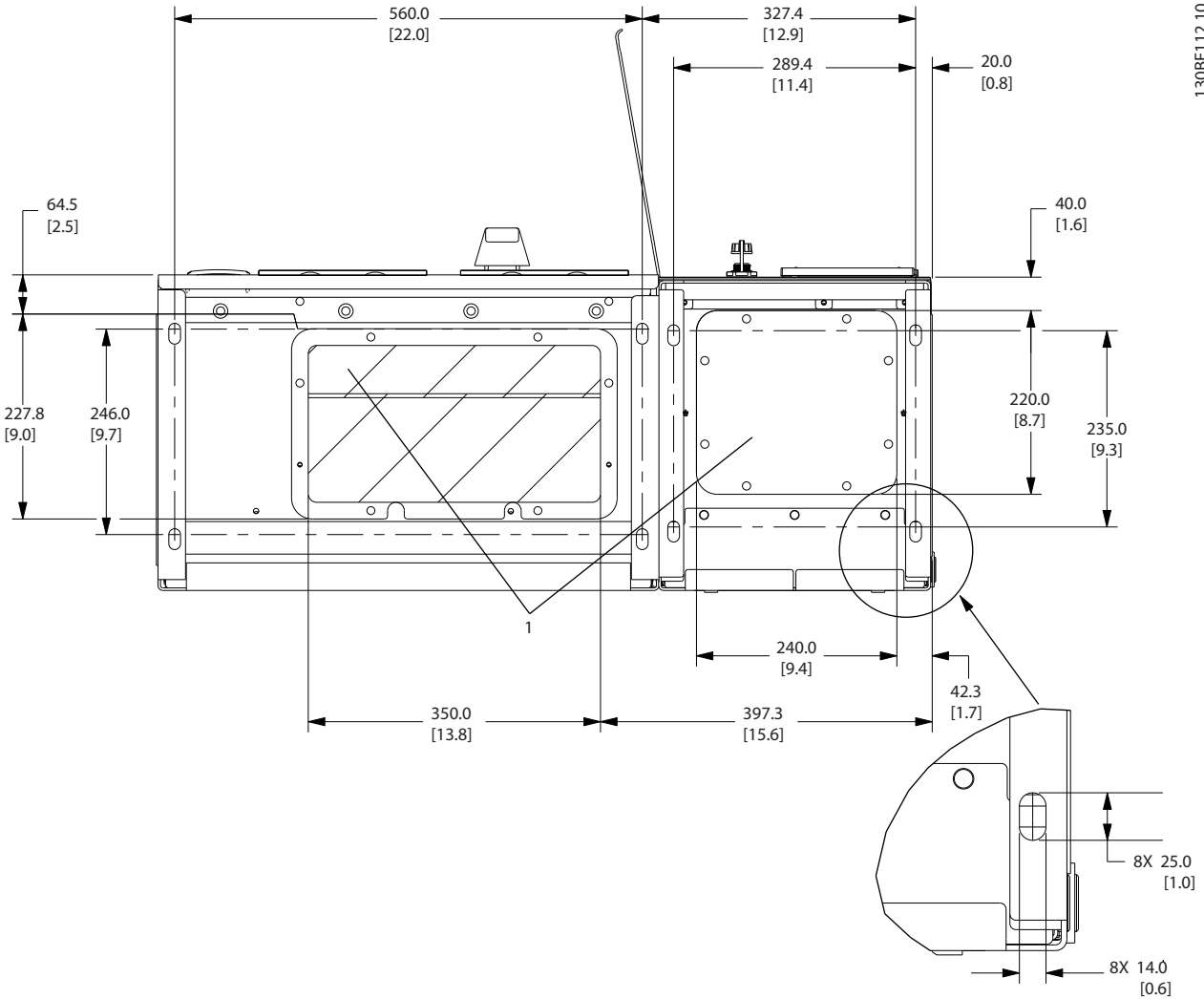

1	Cable entry locations
---	-----------------------

Illustration 3.8 Cable Entry Diagram, Enclosure Size D1n

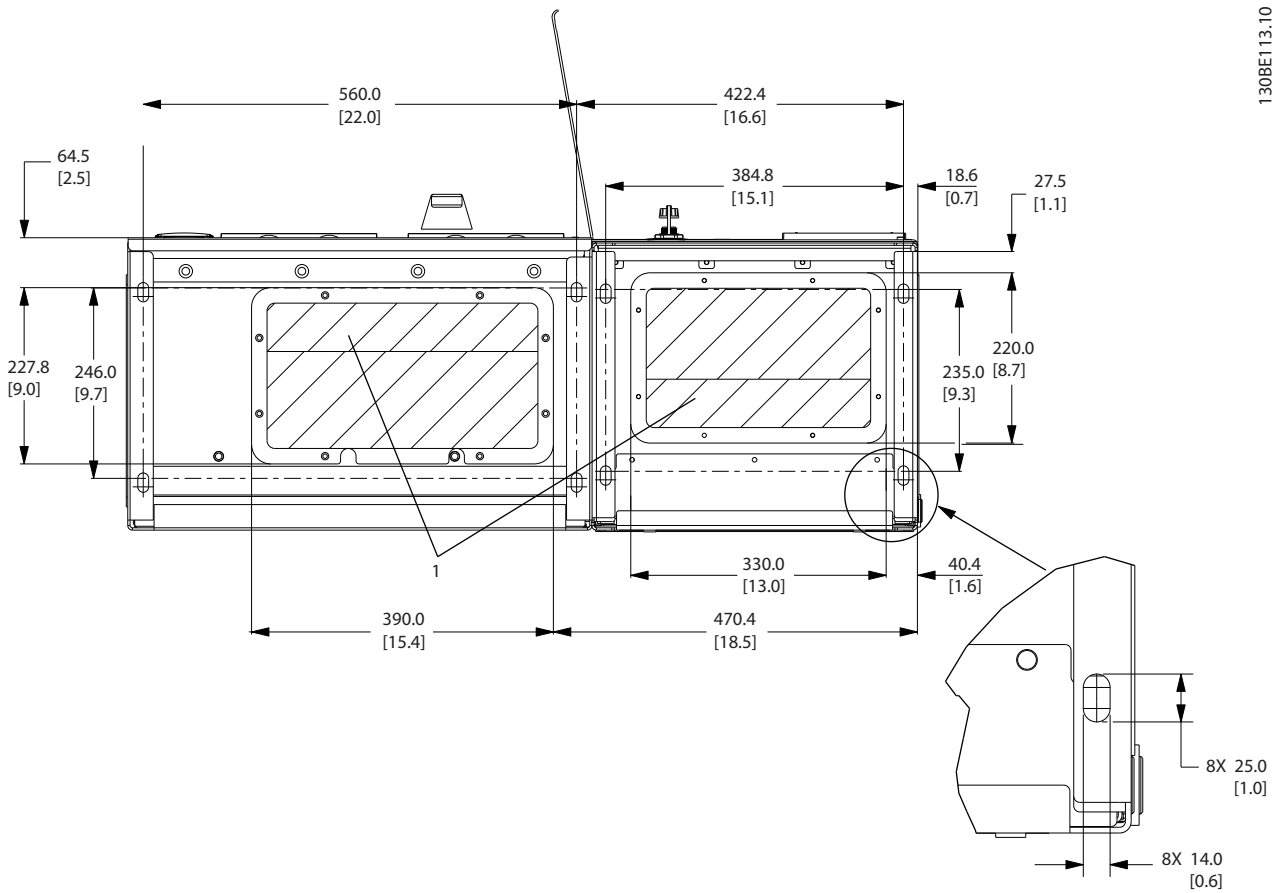

1	Cable entry locations
---	-----------------------

Illustration 3.9 Cable Entry Diagram, Enclosure Size D2n

Bottom view, enclosure size E9

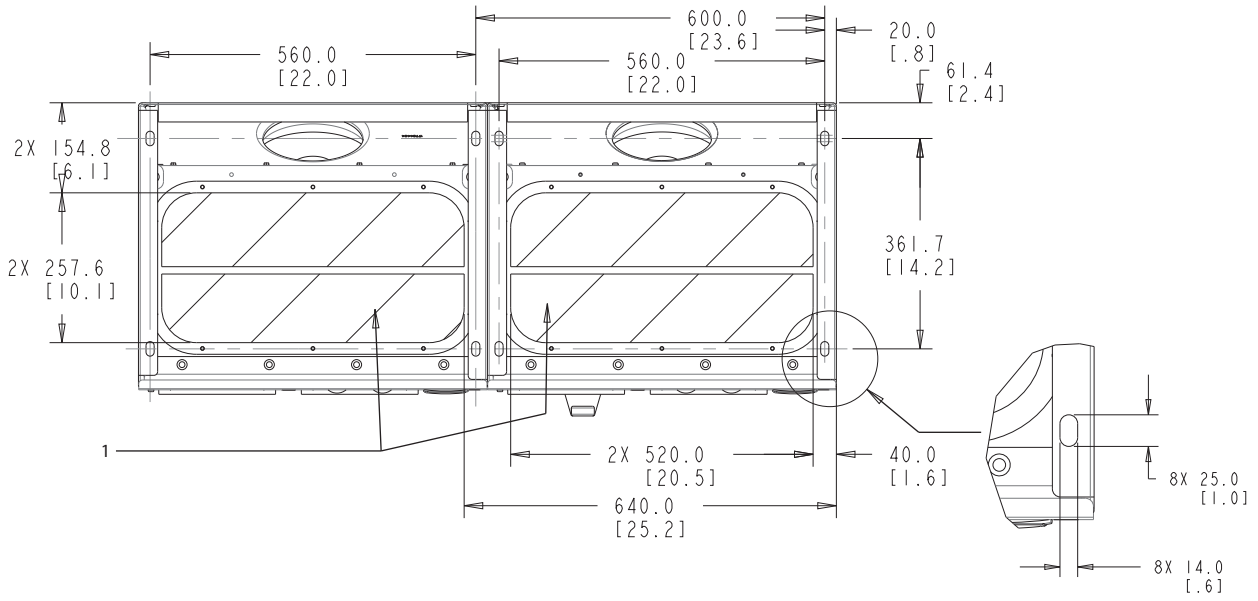

1	Cable entry locations
---	-----------------------

Illustration 3.10 Cable Entry Diagram, E9

Bottom view, F18

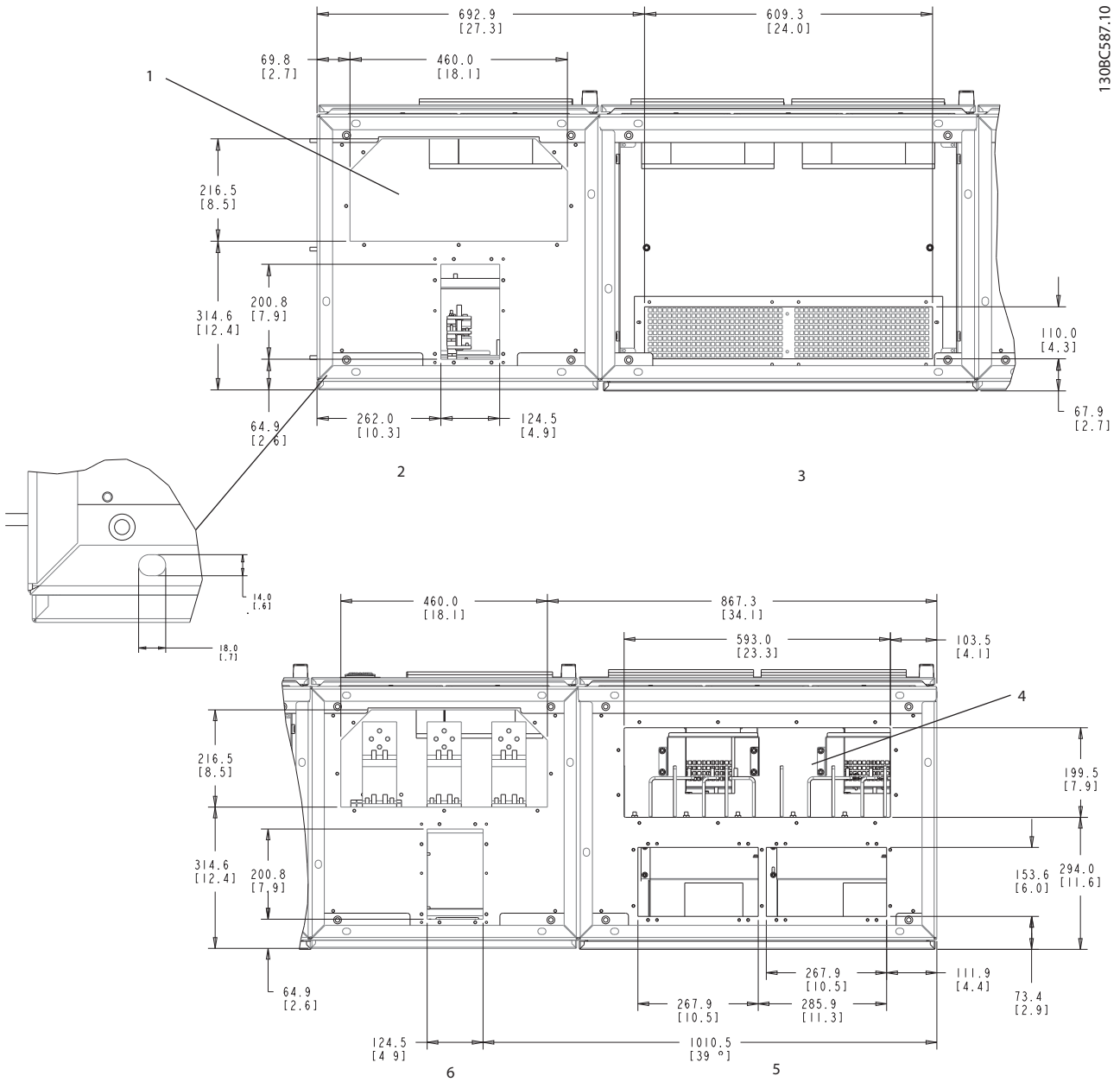

1	Mains cable entry	4	Motor cable entry
2	Option enclosure	5	Inverter enclosure
3	Filter enclosure	6	Rectifier enclosure

Illustration 3.11 Cable Entry Diagram, F18

3.3.4 Terminal Locations for Enclosure Size D1n/D2n

3

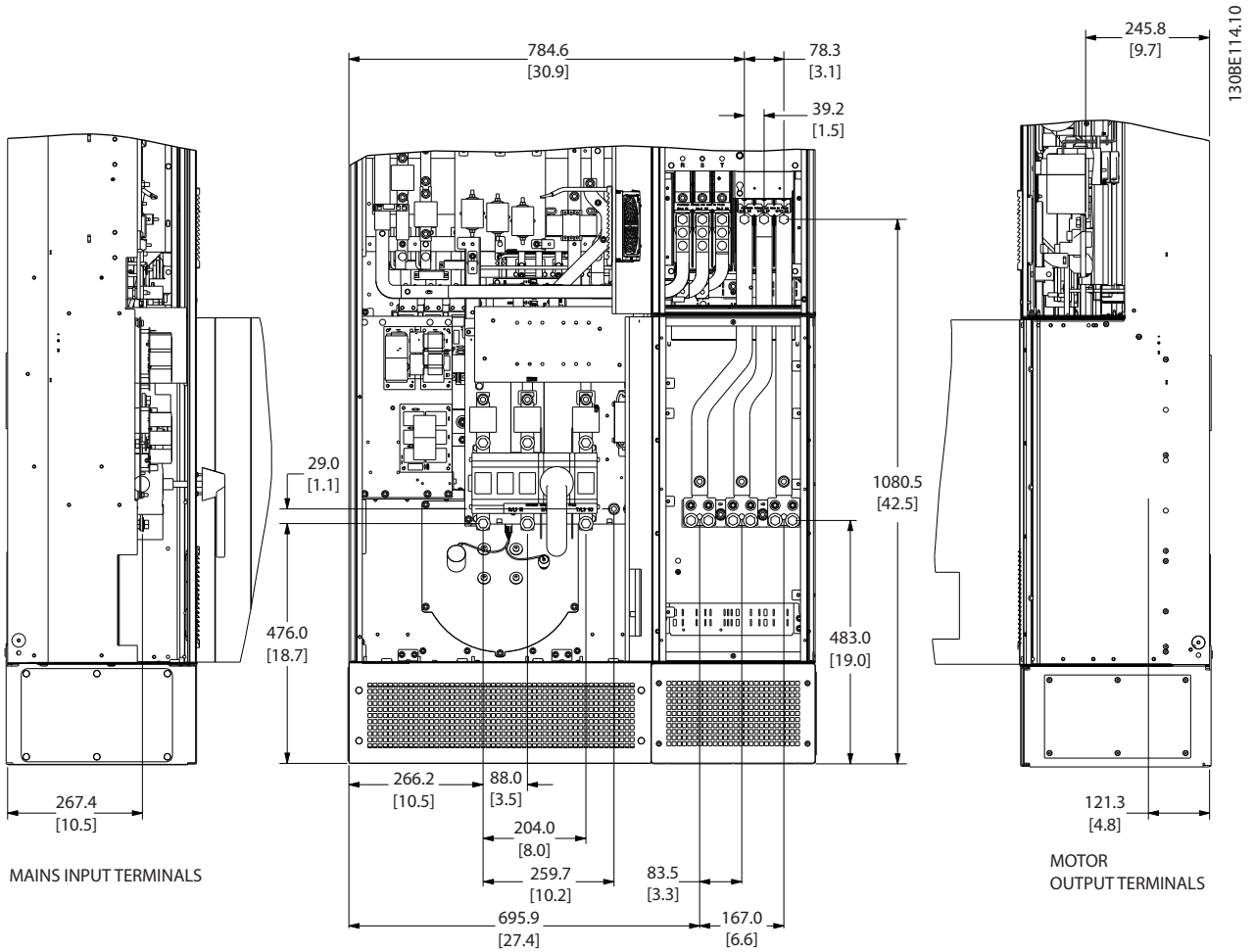
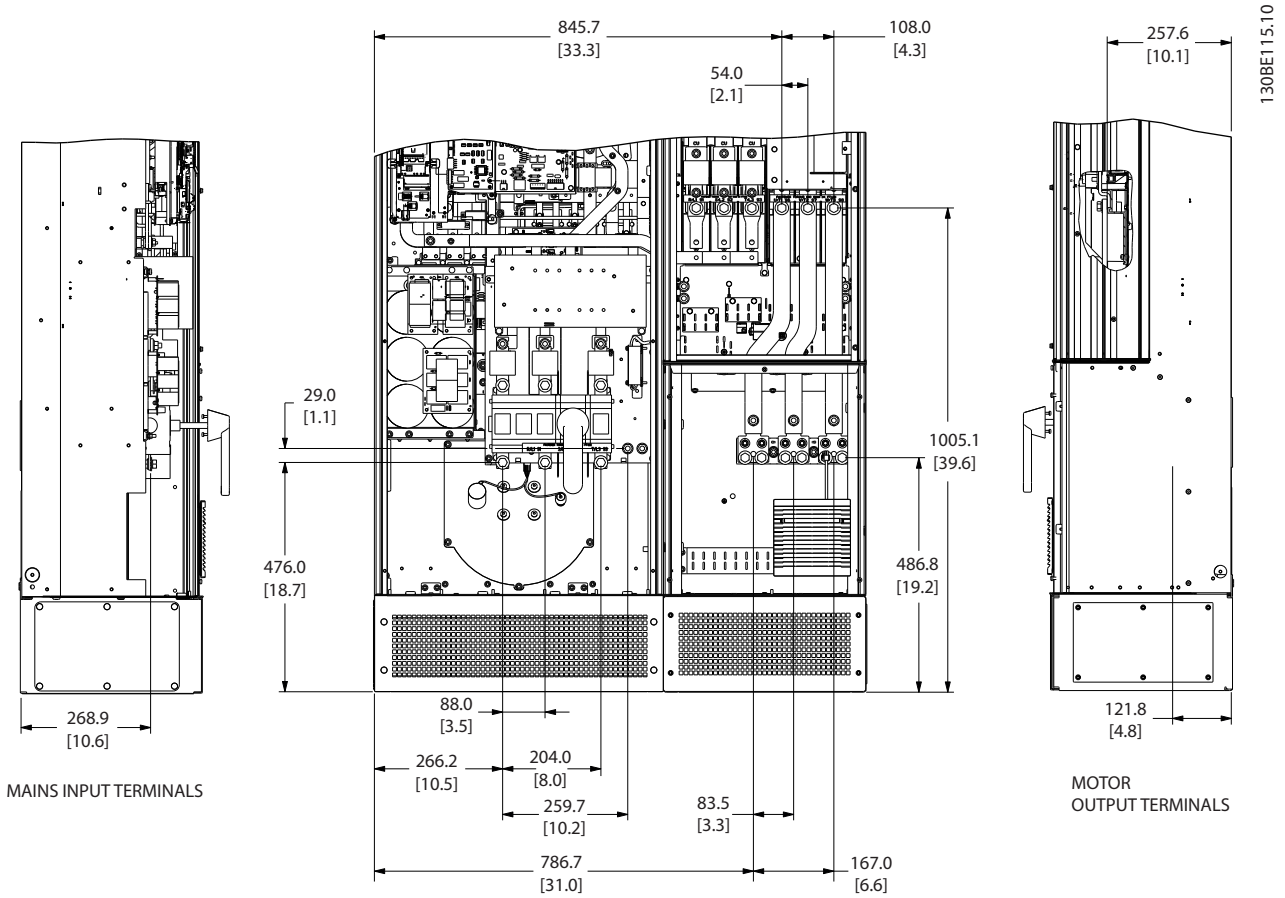

Illustration 3.12 Terminal Locations, Enclosure Size D1n



3

Illustration 3.13 Terminal Locations, Enclosure Size D2n

Allow for bend radius of heavy power cables.

NOTICE

All D-frames are available with standard input terminals, fuse, or disconnect switch.

3.3.5 Terminal Locations for Enclosure Size E9

3

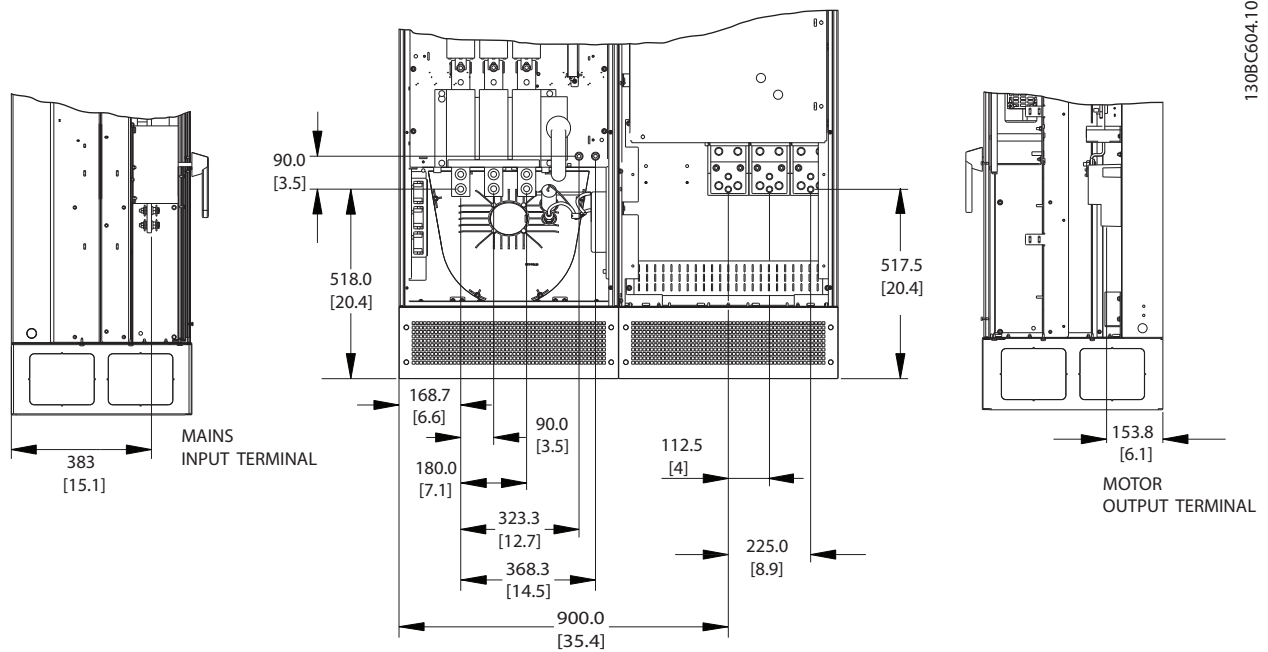

Illustration 3.14 Terminal Locations, Enclosure Size E9

Allow for bend radius of heavy power cables.

NOTICE

All E-frames are available with standard input terminals, fuse, or disconnect switch.

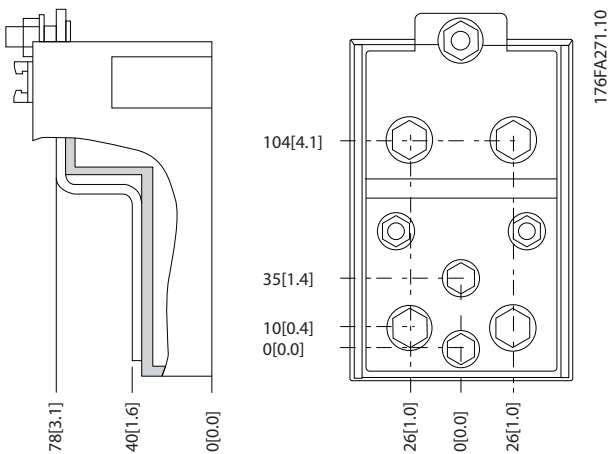

Illustration 3.15 Close-up Terminal Diagrams

3.3.6 Terminal Locations for Enclosure Size F18

Consider the position of the terminals when designing the cable access.

F-frame units have 4 interlocked cabinets:

- Input options cabinet (not optional for LHD)
- Filter cabinet
- Rectifier cabinet
- Inverter cabinet

See *chapter 1.3.3 Exploded View Drawings* for exploded views of each cabinet. Mains inputs are located in the input option cabinet, which conducts power to the rectifier via interconnecting bus bars. Output from the unit is from the inverter cabinet. No connection terminals are located in the rectifier cabinet. Interconnecting bus bars are not shown.

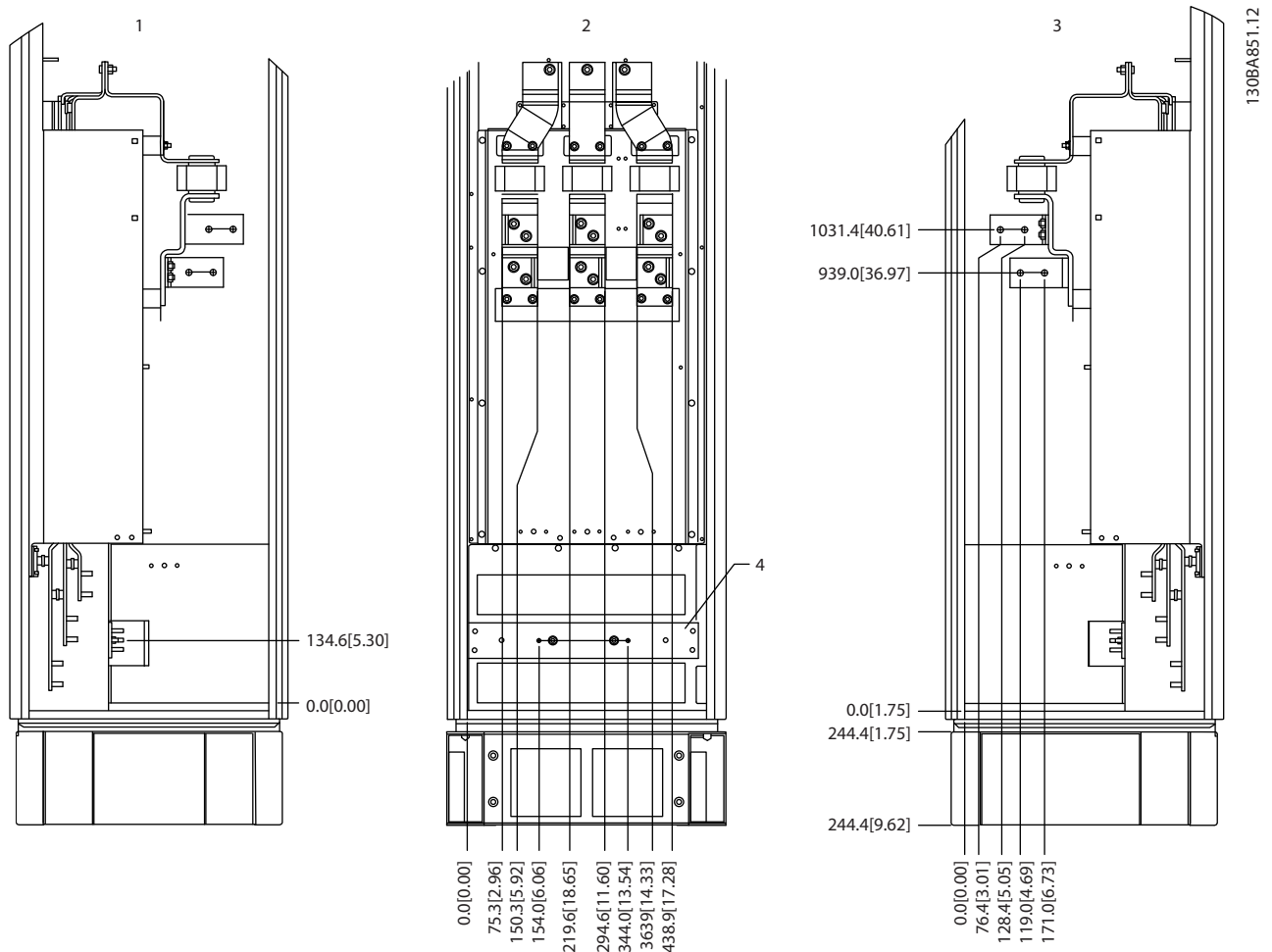

1	Right side cut-away	3	Left side cut-away
2	Front view	4	Ground bar

Illustration 3.16 Input Option Cabinet, Enclosure Size F18 - Fuses Only

The gland plate is 42 mm below the 0 level. Shown are the left side view, front, and right.

3

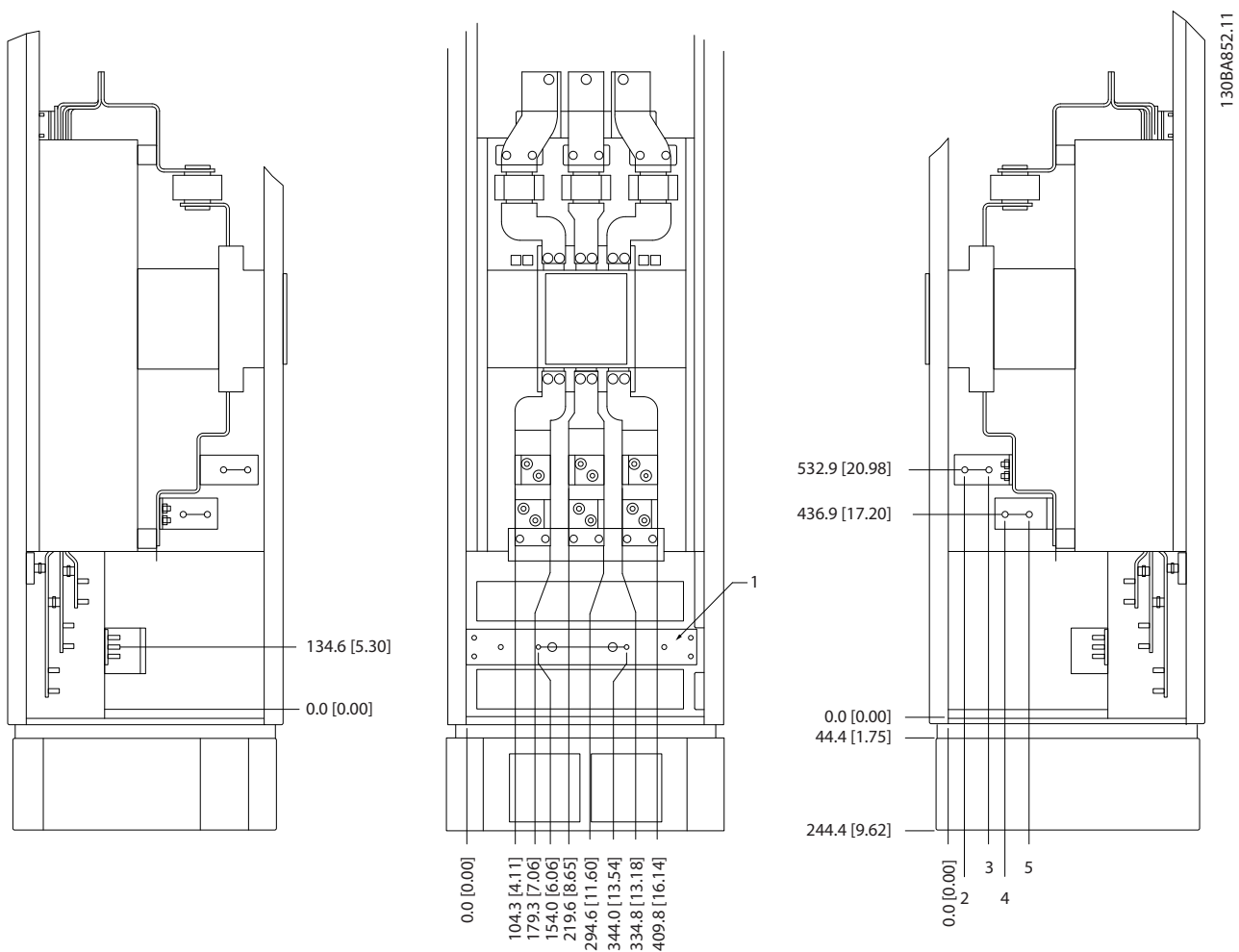

	500 kW ¹⁾ (mm [in.])	560-710 kW ¹⁾ (mm [in.])
1	Ground bar	
2	34.9 [1.4]	46.3 [1.8]
3	86.9 [3.4]	98.3 [3.9]
4	122.2 [4.8]	119 [4.7]
5	174.2 [6.9]	171 [6.7]

1) Disconnect location and related dimensions vary with kilowatt rating.

Illustration 3.17 Input Option Cabinet with Circuit Breaker, Enclosure Size F18

The gland plate is 42 mm below the 0 level. Shown are the left side view, front, and right.

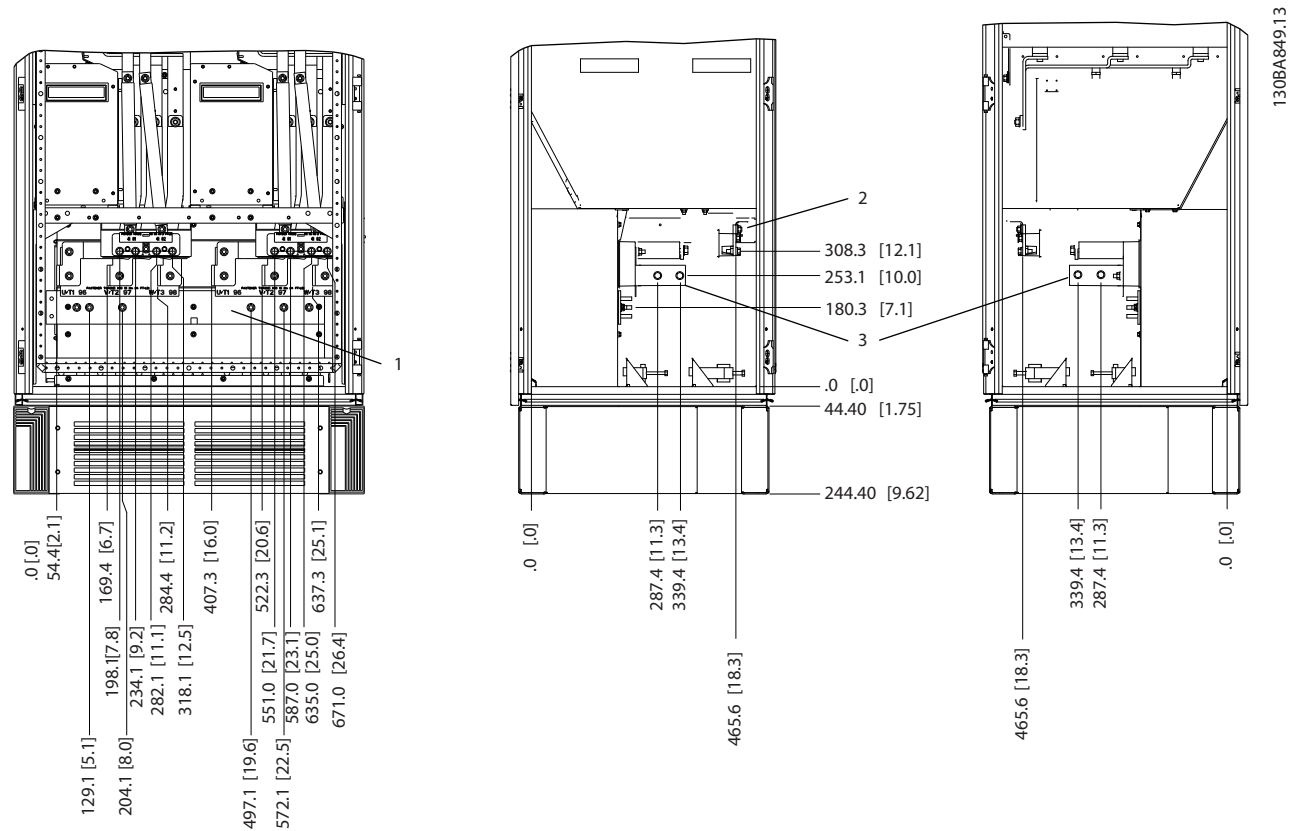

1	Front view
2	Left side view
3	Right side view

Illustration 3.18 Inverter Cabinet, Enclosure Size F18

The gland plate is 42 mm below the 0 level. Shown are the left side view, front, and right.

3.3.7 Torque

Correct torque is imperative for all electrical connections. The correct values are listed in Table 3.2. Incorrect torque results in a bad electrical connection. Use a torque wrench to ensure correct torque.

Enclosure size	Terminal	Torque [Nm] (in-lbs)	Bolt size
D	Mains	19–40	M10
	Motor	(168–354)	
	Regen	8.5–20.5	M8
	Brake	(75–181)	
E	Mains	19–40	M10
	Motor	(168–354)	
	Regen	8.5–20.5	M8
	Brake	(75–181)	

Enclosure size	Terminal	Torque [Nm] (in-lbs)	Bolt size
F	Mains	19–40	M10
	Motor	(168–354)	
	Brake	8.5–20.5 (75–181)	M8
	Regen	8.5–20.5 (75–181)	

Table 3.2 Torque for Terminals

4 Electrical Installation

4.1 Safety Instructions

See *chapter 2 Safety* for general safety instructions.

⚠ WARNING

INDUCED VOLTAGE

Induced voltage from output motor cables that run together can charge equipment capacitors, even with the equipment turned off and locked out. Failure to run output motor cables separately or use screened cables could result in death or serious injury.

- Run output motor cables separately, or
- Use screened cables.

⚠ CAUTION

SHOCK HAZARD

The frequency converter can cause a DC current in the PE conductor. Failure to follow the recommendation means that the RCD may not provide the intended protection.

- When a residual current-operated protective device (RCD) is used for protection against electrical shock, only an RCD of Type B is permitted on the supply side.

Overcurrent protection

- Extra protective equipment, such as short-circuit protection or motor thermal protection between frequency converter and motor, is required for applications with multiple motors.
- Input fusing is required to provide short-circuit and overcurrent protection. If not factory-supplied, the installer must provide fuses. See maximum fuse ratings in *chapter 8.4 Fuses*.

Wire type and ratings

- All wiring must comply with local and national regulations regarding cross-section and ambient temperature requirements.
- Power connection wire recommendation: Minimum 75 °C rated copper wire.

See and *chapter 8.3 General Technical Data* for recommended wire sizes and types.

4.2 Electromagnetic Compatibility (EMC)

To obtain an EMC-compliant installation, follow the instructions provided in *chapter 4.4 Grounding*, *chapter 4.3 Power Connections*, *chapter 4.6 Motor Connection*, and *chapter 4.8 Control Wiring*.

4.2.1 EMC Interference

130BC644:10

4

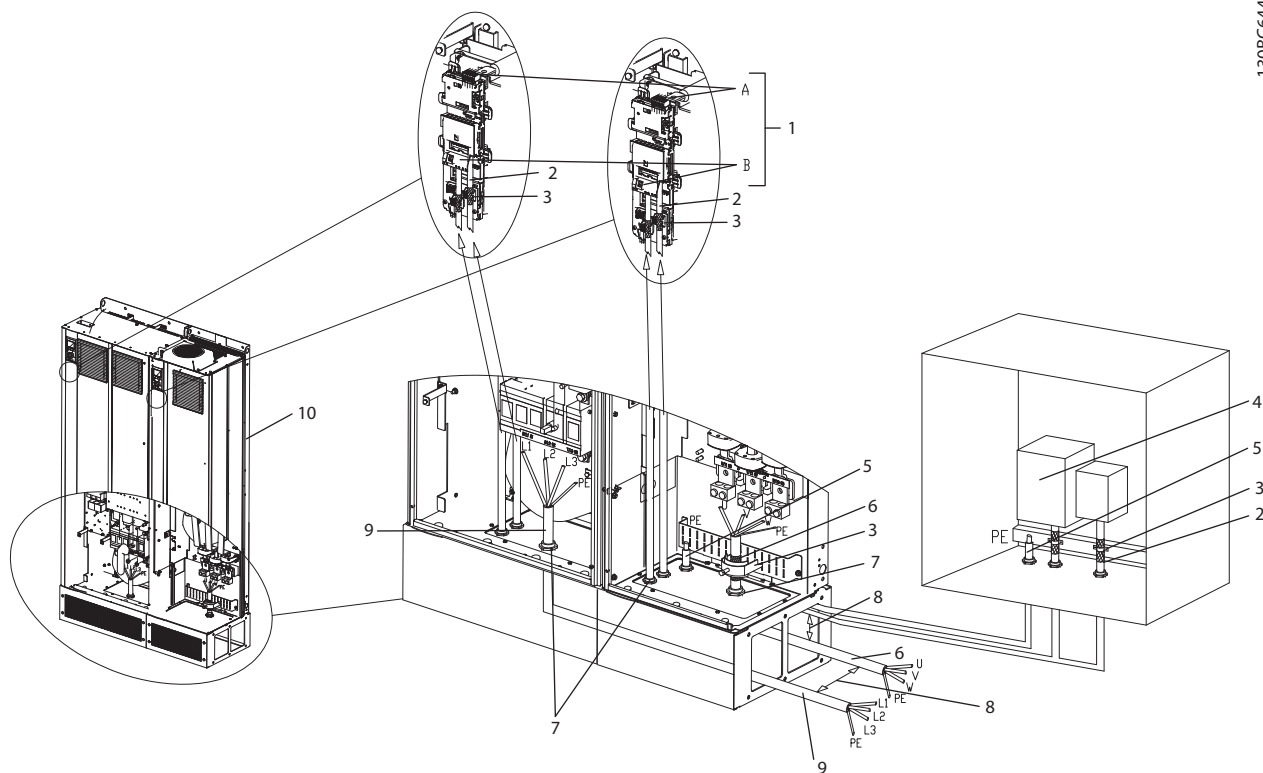

1	Customer control termination points—options A and B	6	Motor output cable, 3-phase and PE (not screened)
2	Screened control wiring	7	Cable gland
3	Cable clamp	8	Clearance, minimum 200 mm
4	Customer control input	9	Mains input cable, 3-phase and reinforce PE (not screened)
5	Potential equalisation wire [minimum 16 mm ²]	10	Low harmonic drive (LHD)

Illustration 4.1 EMC-correct Installation

NOTICE

EMC Interference

Use screened cables for motor and control wiring. Separate the LHD mains input cable, motor cable, and control wiring. Minimum 200 mm (7.9 in) clearance between power, motor, and control cables is required. Maximise this clearance to minimise EMC emissions. This reduces the risk of interference between the LHD and other electronic devices.

4.3 Power Connections

NOTICE

Cables, general information

All cabling must comply with national and local regulations on cable cross-sections and ambient temperature. UL applications require 75 °C copper conductors. For non-UL applications, 75 and 90 °C copper conductors are thermally acceptable.

The power cable connections are located as shown in *Illustration 4.2*. Dimension cable cross-section in accordance with the current ratings and local legislation. See *chapter 8.3.1 Cable lengths and cross-sections* for details.

For protection of the frequency converter, use the recommended fuses if there are no built-in fuses. Fuse recommendations are provided in *chapter 8.4 Fuses*. Ensure that proper fusing is made according to local regulation.

If included, the mains connection is fitted to the mains switch.

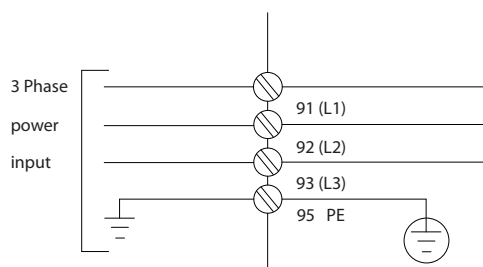

Illustration 4.2 Power Cable Connections

NOTICE

To comply with EMC emission specifications, screened/armoured cables are recommended. If an unscreened/unarmoured cable is used, see *chapter 4.7.3 Power and Control Wiring for Unscreened Cables*.

See *chapter 8 Specifications* for correct dimensioning of motor cable cross-section and length.

Screening of cables

Avoid installation with twisted screen ends (pigtailed). They spoil the screening effect at higher frequencies. If breaking the screen is necessary to install a motor isolator or contactor, continue the screen at the lowest possible HF impedance.

Connect the motor cable screen to both the de-coupling plate of the frequency converter and to the metal housing of the motor.

Make the screen connections with the largest possible surface area (cable clamp). Use the installation devices within the frequency converter.

Cable-length and cross-section

The frequency converter has been EMC-tested with a given cable length. To reduce the noise level and leakage currents, keep the motor cable as short as possible.

Switching frequency

When frequency converters are used with sine-wave filters to reduce the acoustic noise from a motor, set the switching frequency according to *parameter 14-01 Switching Frequency*.

Terminal number	96	97	98	99	
	U	V	W	PE ¹⁾	Motor voltage 0–100% of mains voltage. 3 wires out of motor
	U1	V1	W1	PE ¹⁾	Delta-connected 6 wires out of motor
	U1	V1	W1	PE ¹⁾	Star-connected U2, V2, W2 U2, V2, and W2 to be interconnected separately.

Table 4.1 Terminal Connections

1) Protective earth connection

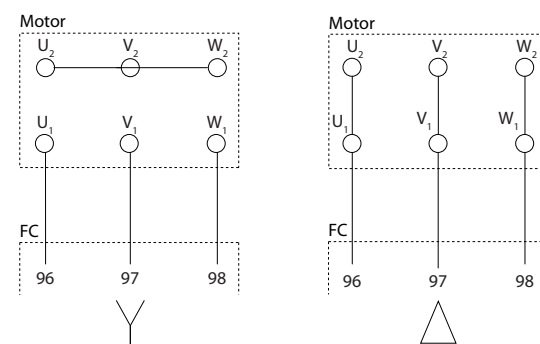

Illustration 4.3 Y and Delta Terminal Configurations

4.4 Grounding

WARNING

GROUNDING HAZARD!

For operator safety, it is important to ground the frequency converter properly in accordance with national and local electrical codes as well as instructions contained within this document. Do not use conduit connected to the frequency converter as a replacement for proper grounding. Ground currents are higher than 3.5 mA. Failure to ground the frequency converter properly could result in death or serious injury.

NOTICE

It is the responsibility of the user or certified electrical installer to ensure correct grounding of the equipment in accordance with national and local electrical codes and standards.

- Follow all local and national electrical codes to ground electrical equipment properly.
- Establish proper protective earthing for equipment with ground currents higher than 3.5 mA, see *chapter 4.4.1 Leakage Current (>3.5 mA)*.
- A dedicated ground wire is required for input power, motor power, and control wiring.
- Use the clamps provided with the equipment for proper ground connections.
- Do not ground one frequency converter to another in a “daisy chain” fashion.
- Keep the ground wire connections as short as possible.
- Using high-strand wire to reduce electrical noise is recommended.
- Follow motor manufacturer wiring requirements.

4.4.1 Leakage Current (>3.5 mA)

Follow national and local codes regarding protective earthing of equipment with a leakage current >3.5 mA. Frequency converter technology implies high frequency switching at high power. This generates a leakage current in the ground connection. A fault current in the frequency converter at the output power terminals might contain a DC component, which can charge the filter capacitors and cause a transient ground current. The earth leakage current depends on various system configurations including RFI filtering, screened motor cables, and frequency converter power.

EN/IEC61800-5-1 (Power Drive System Product Standard) requires special care if the leakage current exceeds 3.5 mA. Grounding must be reinforced in 1 of the following ways:

- Ground wire of at least 10 mm².
- 2 separate ground wires both complying with the dimensioning rules.

See EN 60364-5-54 § 543.7 for further information.

4.5 Input Options

4.5.1 Extra Protection (RCD)

ELCB relays, multiple protective grounding, or standard grounding provide extra protection, if local safety regulations are followed.

In the case of a ground fault, a DC component develops in the fault current.

If using ELCB relays, observe local regulations. Relays must be suitable for protection of 3-phase equipment with a bridge rectifier and for a brief discharge on power-up.

4.5.2 RFI Switch

Mains supply isolated from ground

If the frequency converter is supplied from an isolated mains source or TT/TN-S mains with grounded leg, turn off the RFI switch via *parameter 14-50 RFI Filter* on both frequency converter and the filter. For further reference, see IEC 364-3. When optimum EMC performance is needed, parallel motors are connected, or the motor cable length is above 25 m, set *parameter 14-50 RFI Filter* to [ON]. In OFF, the internal RFI capacitors (filter capacitors) between the enclosure and the DC link are cut off to avoid damage to the intermediate circuit and reduce ground capacity currents (IEC 61800-3). Refer to the application note *VLT on IT mains*. It is important to use isolation monitors that work together with power electronics (IEC 61557-8).

4.5.3 Screened Cables

It is important to connect screened cables properly to ensure high EMC immunity and low emissions.

Connection can be made using either cable glands or clamps:

- EMC cable glands: Generally available cable glands can be used to ensure an optimum EMC connection.
- EMC cable clamp: Clamps allowing easy connection are supplied with the unit.

4.6 Motor Connection

4.6.1 Motor Cable

Connect the motor to terminals U/T1/96, V/T2/97, W/T3/98, on the far right of the unit. Ground to terminal 99. All types of 3-phase asynchronous standard motors can be used with a frequency converter. The factory setting is for clockwise rotation with the frequency converter output connected as follows:

Terminal number	Function
96, 97, 98	Mains U/T1, V/T2, W/T3
99	Ground

Table 4.2 Terminal Functions

- Terminal U/T1/96 connected to U-phase.
- Terminal V/T2/97 connected to V-phase.
- Terminal W/T3/98 connected to W-phase.

The direction of rotation can be changed by switching 2 phases in the motor cable or by changing the setting of parameter 4-10 Motor Speed Direction.

4

Motor rotation check can be performed via parameter 1-28 Motor Rotation Check and following the steps shown in the display.

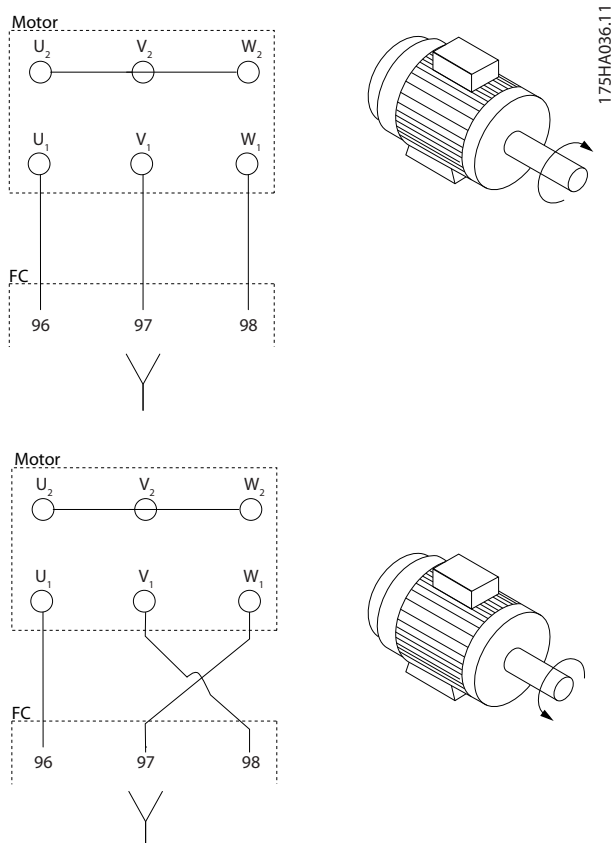

Illustration 4.4 Motor Rotation Check

F-frame requirements

Use motor phase cables in quantities of 2, resulting in 2, 4, 6, or 8 to obtain an equal number of wires on both inverter module terminals. The cables are required to be equal length within 10% between the inverter module terminals and the first common point of a phase. The recommended common point is the motor terminals.

Output junction box requirements

The length, minimum 2.5 m, and quantity of cables must be equal from each inverter module to the common terminal in the junction box.

NOTICE

If a retrofit application requires an unequal number of wires per phase, consult the factory or use the top/bottom entry side cabinet option instruction.

4.6.2 Brake Cable

Frequency converters with factory installed brake chopper option.

(Only standard with letter B in position 18 in the type code).

The connection cable to the brake resistor must be screened and the maximum length from frequency converter to the DC bar is limited to 25 m.

Terminal number	Function
81, 82	Brake resistor terminals

Table 4.3 Terminal Functions

The connection cable to the brake resistor must be screened. Connect the screen with cable clamps to the conductive back plate of the frequency converter and the metal cabinet of the brake resistor.

Size the brake cable cross-section to match the brake torque.

WARNING

Note that voltages up to 790 V DC, depending on the supply voltage, are possible on the terminals.

F-frame requirements

Connect the brake resistors to the brake terminals in each inverter module.

4.6.3 Motor Insulation

For motor cable lengths ≤ the maximum cable length, the motor insulation ratings listed in Table 4.4 are recommended. The peak voltage can be twice the DC-link voltage or 2.8 times mains voltage, due to transmission line effects in the motor cable. If a motor has lower insulation rating, use a dU/dt or sine wave filter.

Nominal mains voltage	Motor insulation
$U_N \leq 420$ V	Standard $U_{LL} = 1300$ V
420 V $< U_N \leq 500$ V	Reinforced $U_{LL} = 1600$ V

Table 4.4 Recommended Motor Insulation Ratings

4.6.4 Motor Bearing Currents

Motors with a rating of 110 kW or higher combined with frequency converters are best with NDE (non-drive end) insulated bearings to eliminate circulating bearing currents caused by motor size. To minimise DE (drive end) bearing and shaft currents, proper grounding is required for:

- The frequency converter.
- The motor.
- Motor-driven machine.
- Motor to the driven machine.

Although failure due to bearing currents is infrequent, use the following strategies to reduce the likelihood:

- Use an insulated bearing.
- Apply rigorous installation procedures.
- Ensure that the motor and load motor are aligned.
- Strictly follow the EMC Installation guideline.
- Reinforce the PE so the high frequency impedance is lower in the PE than the input power leads.
- Provide a good high frequency connection between the motor and the frequency converter.
- Ensure that the impedance from frequency converter to building ground is lower than the grounding impedance of the machine. Make a direct ground connection between the motor and load motor.
- Apply conductive lubrication.
- Balance the line voltage to ground.
- Use an insulated bearing as recommended by the motor manufacturer.

NOTICE

Motors from reputable manufacturers typically have insulated bearings as standard in motors of this size.

If necessary, and after consultation with Danfoss:

- Lower the IGBT switching frequency.
- Modify the inverter waveform, 60° AVM vs. SFAVM.
- Install a shaft grounding system or use an isolating coupling between motor and load.
- Use minimum speed settings if possible.
- Use a dU/dt or sine-wave filter.

4.7 AC Mains Connection

4.7.1 Mains Connection

Connect mains to terminals 91, 92, and 93 on the far left of the unit. Ground is connected to the terminal on the right of terminal 93.

Terminal number	Function
91, 92, 93	Mains R/L1, S/L2, T/L3
94	Ground

Table 4.5 Terminal Functions

Ensure sufficient current supply to the frequency converter.

If the unit is without built-in fuses, ensure that the appropriate fuses have the correct current rating.

4.7.2 External Fan Supply

NOTICE

Applicable for E and F enclosures only.

If the frequency converter is supplied by DC, or the fan must run independently of the supply, use an external supply. Make the connection on the power card.

Terminal number	Function
100, 101	Auxiliary supply S, T
102, 103	Internal supply S, T

Table 4.6 Terminal Functions

The connector on the power card provides the connection of line voltage for the cooling fans. The fans are connected from the factory to be supplied from a common AC line (jumpers between 100–102 and 101–103). If external supply is needed, remove the jumpers and connect the supply to terminals 100 and 101. Protect with a 5 A fuse. In UL applications, use a Littelfuse KLK-5 or equivalent.

4.7.3 Power and Control Wiring for Unscreened Cables

⚠ WARNING

INDUCED VOLTAGE

Induced voltage from coupled output motor cables charges equipment capacitors even with the equipment turned off and locked out. Run motor cables from multiple frequency converters separately. Failure to run output cables separately could result in death or serious injury.

⚠ CAUTION

COMPROMISED PERFORMANCE

The frequency converter runs less efficiently if wiring is not isolated properly. To isolate high frequency noise, place the following in separate metallic conduits:

- Power wiring
- Motor wiring
- Control wiring

Failure to isolate these connections could result in less than optimum controller and associated equipment performance.

Because the power wiring carries high-frequency electrical pulses, it is important to run input power and motor power in separate conduit. If incoming power wiring is in the same conduit as motor wiring, these pulses can couple electrical noise back onto the power grid. Isolate control wiring from high-voltage power wiring. See *Illustration 4.5*. When screened/armoured cable is not used, at least 3 separate conduits are connected to the panel options cabinet.

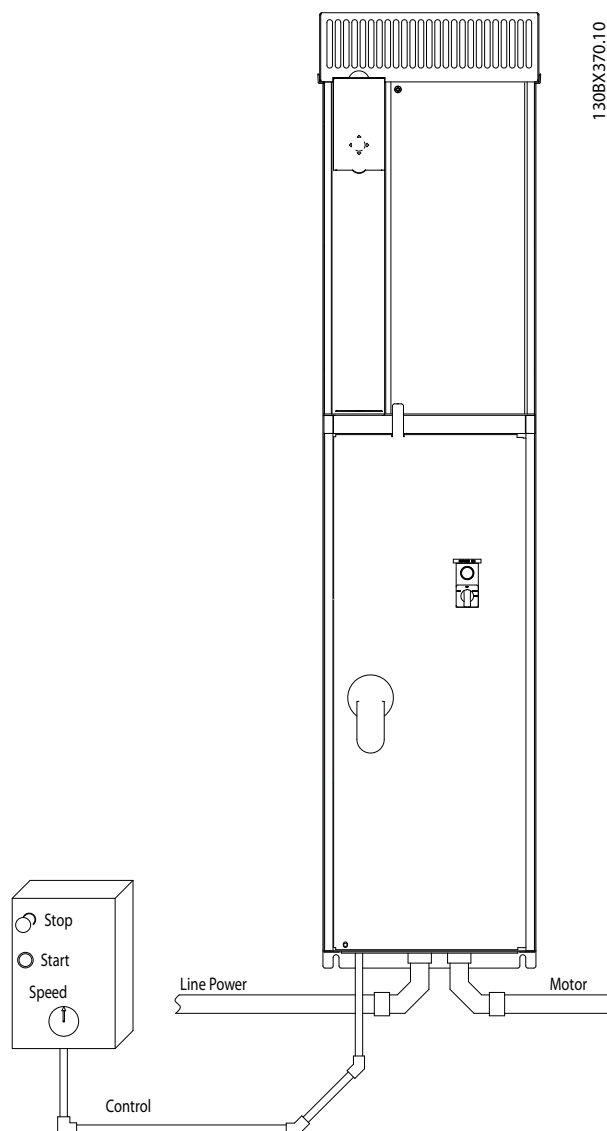

Illustration 4.5 Example of Proper Electrical Installation Using Conduit

4.7.4 Mains Disconnects

Enclosure size	Power and voltage	Type
D	132–200 kW 380–500 V	OT400U12-9 or ABB OETL-NF400A
E	250 kW 380–500 V	ABB OETL-NF600A
E	315–400 kW 380–500 V	ABB OETL-NF800A
F	450 kW 380–500 V	Merlin Gerin NPJF36000S12AAYP
F	500–630 kW 380–500 V	Merlin Gerin NRK36000S20AAYP

Table 4.7 Recommended Mains Disconnects

4.7.5 F-Frame Circuit Breakers

Enclosure size	Power and voltage	Type
F	450 kW 380–500 V	Merlin Gerin NPJF36120U31AABSCYP
F	500–630 kW 380–500 V	Merlin Gerin NRJF36200U31AABSCYP

Table 4.8 Recommended Circuit Breakers

4.7.6 F-Frame Mains Contactors

Enclosure size	Power and voltage	Type
F	450–500kW 380–500 V	Eaton XTCE650N22A
F	560–630kW380–500 V	Eaton XTCEC14P22B

Table 4.9 Recommended Contactors

4.8 Control Wiring

4.8.1 Control Cable Routing

Tie down all control wires to the designated control cable routing as shown in *Illustration 4.6*, *Illustration 4.7*, *Illustration 4.8*, and *Illustration 4.9*. Remember to connect the shields in a proper way to ensure optimum electrical immunity.

Fieldbus connection

Connections are made to the relevant options on the control card. For details, see the relevant fieldbus instruction. The cable must either be entered through the access point in the top or be placed in the provided path inside the frequency converter and tied down with other control wires (see *Illustration 4.6*, *Illustration 4.7*, and *Illustration 4.8*).

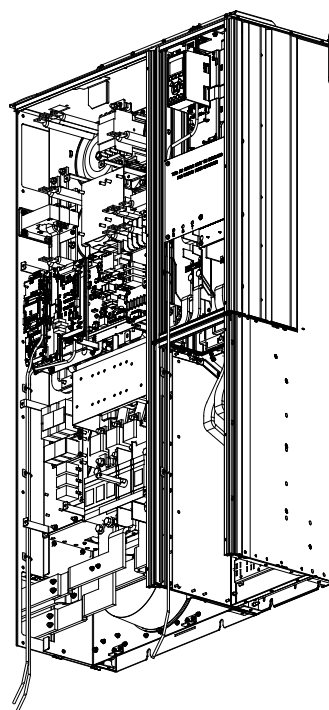

Illustration 4.6 Control Card Wiring Path for Enclosure Size D1n

4

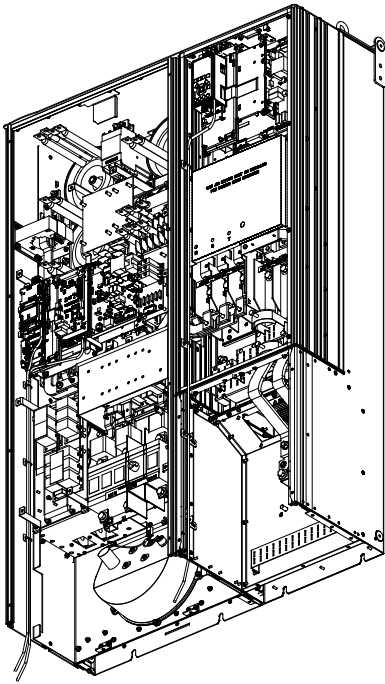

Illustration 4.7 Control Card Wiring Path for Enclosure Size D2n

130BE1371.0

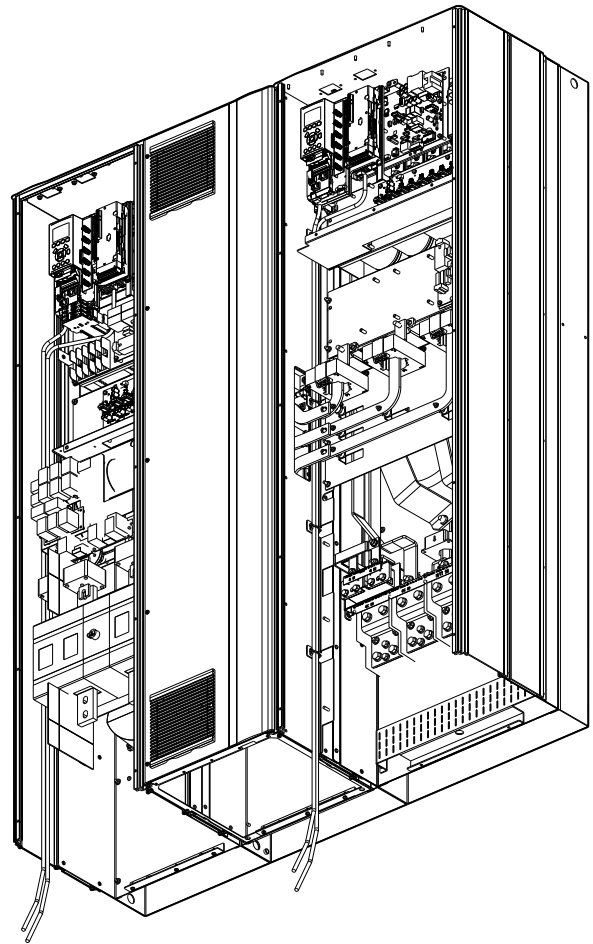
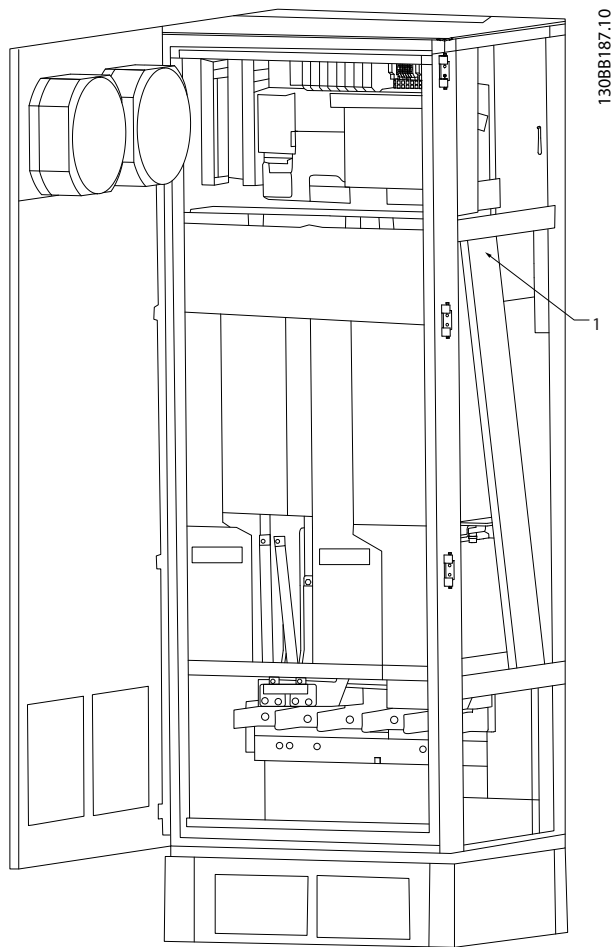

Illustration 4.8 Control Card Wiring Path for Enclosure Size E9

130BB429.10



1 Routing path for the control card wiring inside the frequency converter enclosure.

Illustration 4.9 Control Card Wiring Path for Enclosure Size F18

4.8.2 Access to Control Terminals

All terminals for the control cables are located beneath the LCP (both filter and frequency converter LCPs). They are accessed by opening the door of the unit.

4.8.3 Electrical Installation, Control Terminals

To connect the cable to the terminal:

1. Strip insulation by about 9–10 mm.

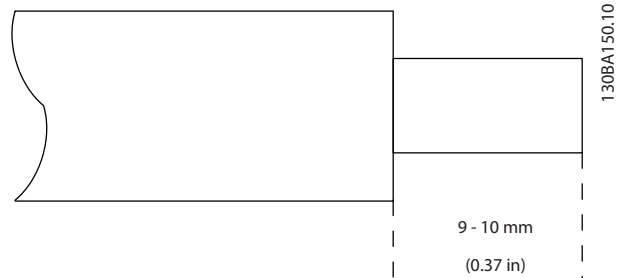

Illustration 4.10 Length to Strip the Insulation

2. Insert a screwdriver (maximum 0.4 x 2.5 mm) in the square hole.
3. Insert the cable in the adjacent circular hole.

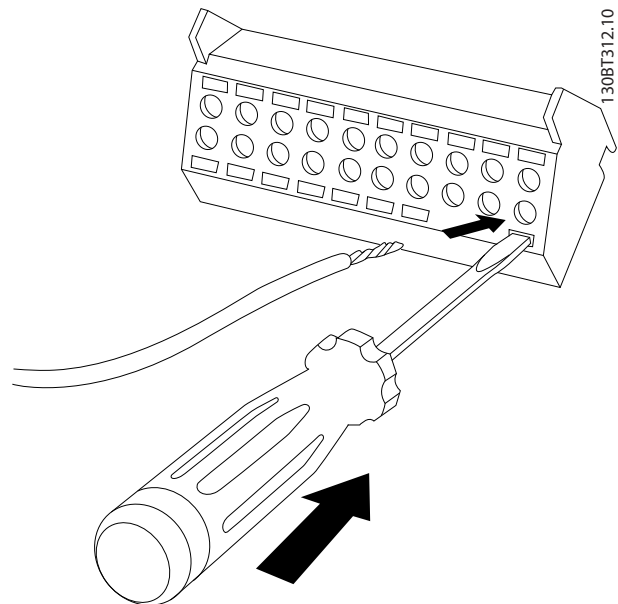

Illustration 4.11 Inserting the Cable in the Terminal Block

4. Remove the screwdriver. The cable is now mounted in the terminal.

To remove the cable from the terminal:

1. Insert a screwdriver (maximum 0.4 x 2.5 mm) in the square hole.
2. Pull out the cable.

4

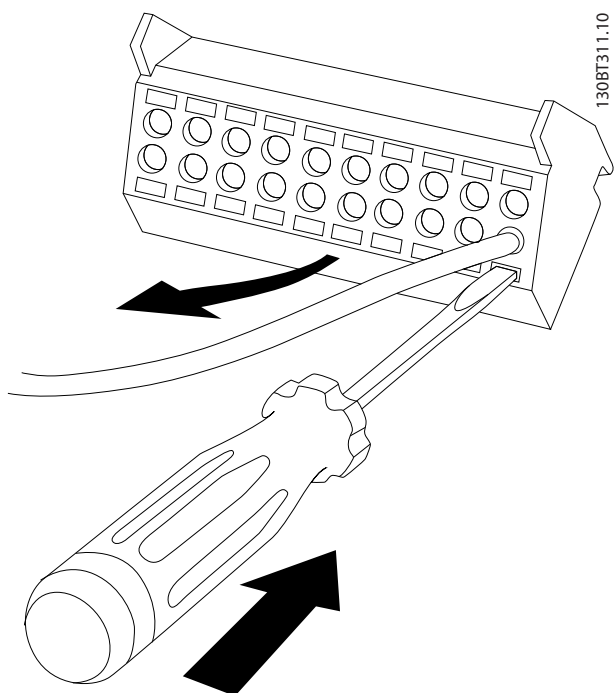

Illustration 4.12 Removing the Screwdriver after Cable Insertion

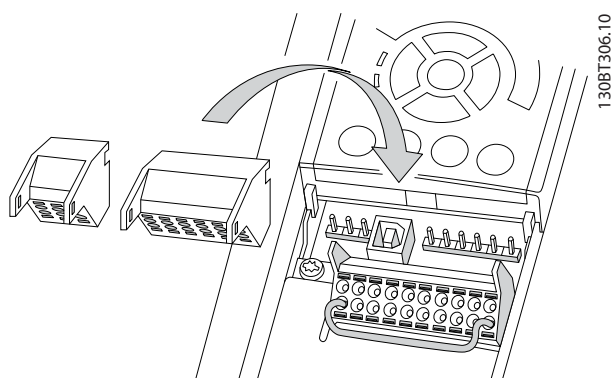
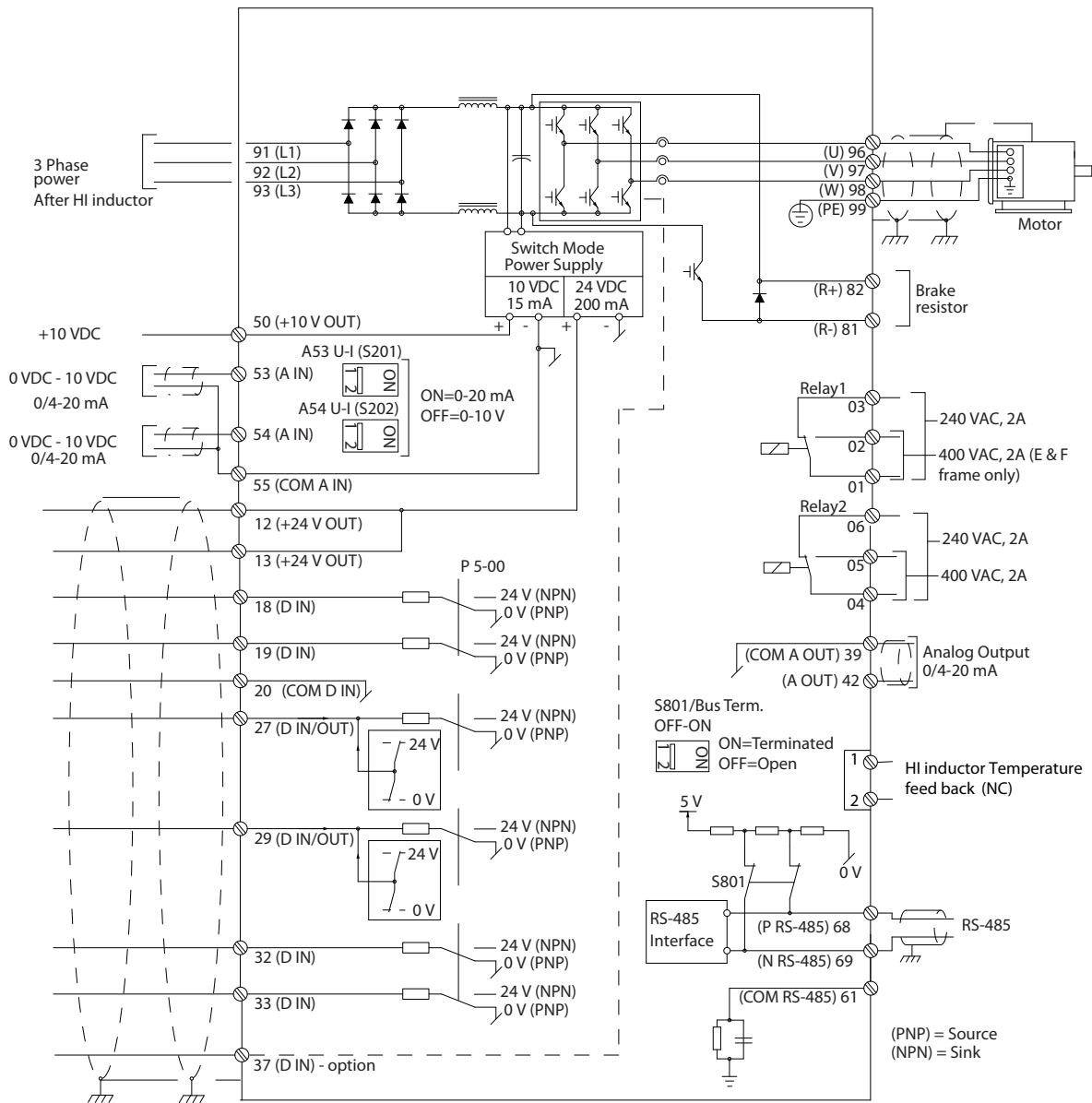

Illustration 4.13 Control Terminal Locations

4.8.4 Electrical Installation, Control Cables



130BE195.10

Illustration 4.14 Terminal Diagram for the Frequency Converter Side

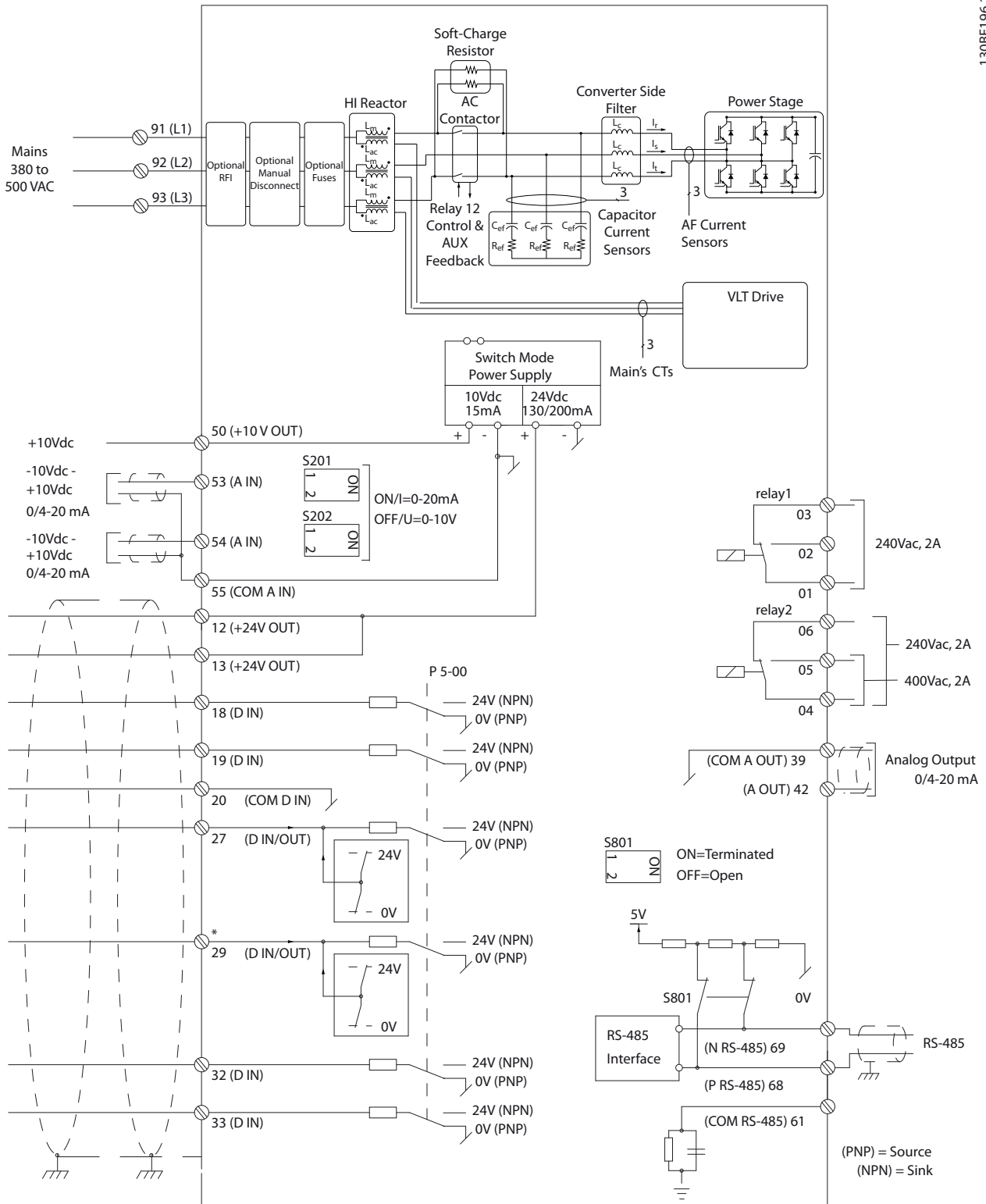

Illustration 4.15 Terminal Diagram for the Filter Side

4.8.5 Safe Torque Off (STO)

To run STO, additional wiring for the frequency converter is required. Refer to *VLT® Frequency Converters Safe Torque Off Operating Instructions* for further information.

4.9 Additional Connections

4.9.1 Serial Communication

RS485 is a 2-wire bus interface compatible with multi-drop network topology, that is nodes can be connected as a bus, or via drop cables from a common trunk line. A total of 32 nodes can be connected to 1 network segment. Repeaters divide networks.

NOTICE

Each repeater functions as a node within the segment in which it is installed. Each node connected within a given network must have a unique node address across all segments.

Terminate each segment at both ends, using either the termination switch (S801) of the frequency converters or a biased termination resistor network. Always use screened twisted pair (STP) cable for bus cabling, and always follow good common installation practice.

Low-impedance ground connection of the screen at every node is important, including at high frequencies. Thus, connect a large surface of the screen to ground, for example with a cable clamp or a conductive cable gland. It may be necessary to apply potential-equalizing cables to maintain the same ground potential throughout the network, particularly in installations with long cables. To prevent impedance mismatch, always use the same type of cable throughout the entire network. When connecting a motor to the frequency converters, always use screened motor cable.

Cable	Screened twisted pair (STP)
Impedance	120 Ω
Cable length [m]	Maximum 1200 (including drop lines) Maximum 500 station-to-station

Table 4.10 Cable Recommendations

4.9.2 Mechanical Brake Control

In hoisting/lowering applications, it is necessary to be able to control an electro-mechanical brake:

- Control the brake using any relay output or digital output (terminal 27 or 29).
- Keep the output closed (voltage-free) as long as the frequency converter is unable to support the motor, due to the load being too heavy, for example.
- Select [32] *Mechanical brake control* in parameter group 5-4* *Relays* for applications with an electro-mechanical brake.
- The brake is released when the motor current exceeds the preset value in *parameter 2-20 Release Brake Current*.
- The brake engages when the output frequency is less than the frequency set in *parameter 2-21 Activate Brake Speed [RPM]* or *parameter 2-22 Activate Brake Speed [Hz]*, only if the frequency converter completes a stop command.

If the frequency converter is in alarm mode or in an overvoltage situation, the mechanical brake immediately cuts in.

4.9.3 Parallel Connection of Motors

The frequency converter can control several parallel-connected motors. The total current consumption of the motors must not exceed the rated output current $I_{M,N}$ for the frequency converter.

NOTICE

Installations with cables connected in a common joint as in *Illustration 4.16* are only recommended for short cable lengths.

NOTICE

When motors are connected in parallel, *parameter 1-29 Automatic Motor Adaptation (AMA)* cannot be used.

NOTICE

The electronic thermal relay (ETR) of the frequency converter cannot be used as motor protection for the individual motor in systems with parallel-connected motors. Provide further motor protection with thermistors in each motor or individual thermal relays. Circuit breakers are not suitable as protection.

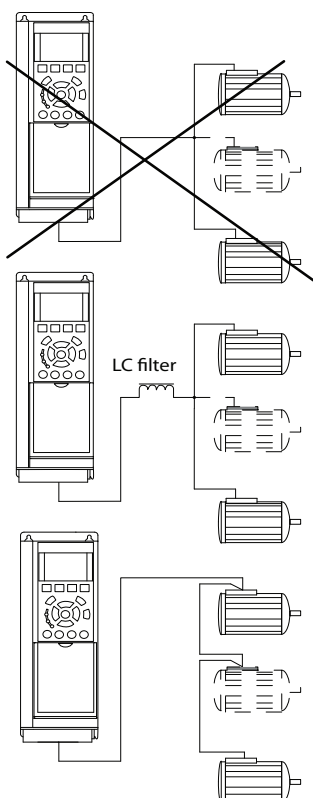

Illustration 4.16 Installations with Cables Connected in a Common Joint

Problems are possible at start and at low RPM values if motor sizes vary widely. The relatively high ohmic resistance in the stator of small motors calls for a higher voltage at start and at low RPM values.

4.9.4 Motor Thermal Protection

The electronic thermal relay in the frequency converter has received UL-approval for single motor protection, when *parameter 1-90 Motor Thermal Protection* is set for [4] ETR Trip 1 and *parameter 1-24 Motor Current* is set to the rated motor current (see motor nameplate).

For the North American market: The ETR functions provide class 20 motor overload protection in accordance with NEC.

For motor thermal protection, it is also possible to use the VLT® PTC Thermistor Card MCB 112. This card provides ATEX certification to protect motors in explosion hazardous areas, Zone 1/21 and Zone 2/22. When *parameter 1-90 Motor Thermal Protection* is set to [20] ATEX ETR and MCB 112 are combined, it is possible to control an Ex-e motor in explosion hazardous areas. Consult the *Programming Guide* for details on how to set up the frequency converter for safe operation of Ex-e motors.

4.9.5 Voltage/Current Input Selection (Switches)

The analog mains terminals 53 and 54 allow setting of input signal to voltage (0–10 V) or current (0/4–20 mA). See *Illustration 4.14* and *Illustration 4.15* for the location of the control terminals within the low harmonic drive.

Default parameter settings:

- Terminal 53: Speed reference signal in open loop (see *parameter 16-61 Terminal 53 Switch Setting*).
- Terminal 54: Feedback signal in closed loop (see *parameter 16-63 Terminal 54 Switch Setting*).

NOTICE

REMOVE POWER

Remove power to the low harmonic drive before changing switch positions.

1. Remove the LCP (see *Illustration 4.17*).
2. Remove any optional equipment covering the switches.
3. Set switches A53 and A54 to select the signal type. U selects voltage, I selects current.

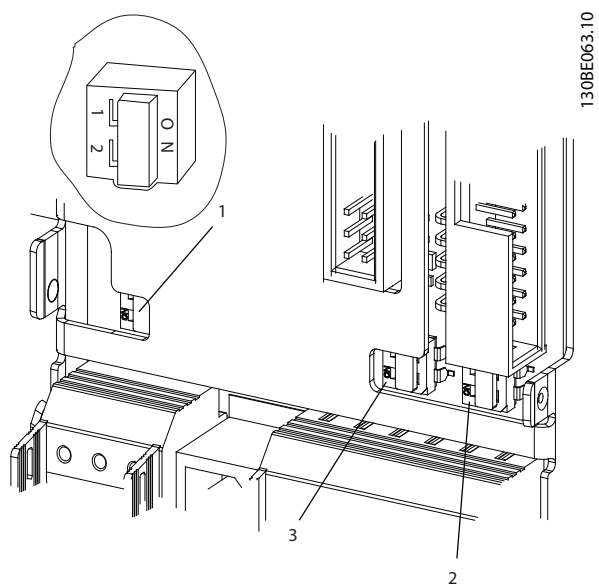

130BE063.10

130BT307.10

1	Bus termination switch
2	A54 switch
3	A53 switch

Illustration 4.17 Bus Termination Switch, A53, and A54 Switch Locations

4.10 Final Set-up and Test

Before operating the frequency converter, perform a final test of the installation:

1. Locate the motor name plate to find out whether the motor is star- (Y) or delta- connected (Δ).
2. Enter the motor name plate data in the parameter list. Access the list by pressing the [Quick Menu] key and selecting Q2 Quick Set-up. See Table 4.11.

1.	Parameter 1-20 Motor Power [kW] Parameter 1-21 Motor Power [HP]
2.	Parameter 1-22 Motor Voltage
3.	Parameter 1-23 Motor Frequency
4.	Parameter 1-24 Motor Current
5.	Parameter 1-25 Motor Nominal Speed

Table 4.11 Quick Set-up Parameters

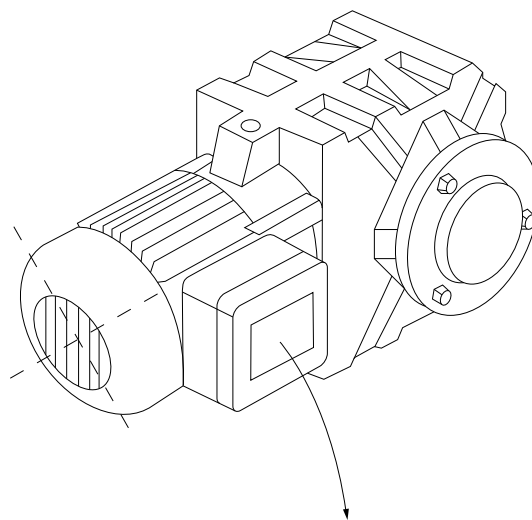

BAUER D-7 3734 ESLINGEN				
3~ MOTOR NR. 1827421 2003				
S/E005A9				
	1,5	KW		
n ₂	31,5	/min.	400	Y V
n ₁	1400	/min.	50	Hz
COS θ	0,80		3,6	A
1,7L				
B	IP 65		H1/1A	

Illustration 4.18 Motor Name Plate

3. Perform an automatic motor adaptation (AMA) to ensure optimum performance.
 - 3a Connect terminal 27 to terminal 12 or set *parameter 5-12 Terminal 27 Digital Input* to [0] No operation.
 - 3b Activate the AMA in *parameter 1-29 Automatic Motor Adaptation (AMA)*.
 - 3c Select either complete or reduced AMA. If an LC filter is mounted, run only the reduced AMA, or remove the LC filter during the AMA procedure.
 - 3d Press [OK]. The display shows *Press [Hand On] to start*.
 - 3e Press [Hand On]. A progress bar indicates whether the AMA is in progress.
 - 3f Press [Off] - the frequency converter enters alarm mode and the display shows that the user terminated AMA.

Stop the AMA during operation

Successful AMA

- The display shows *Press [OK] to finish AMA*.
- Press [OK] to exit the AMA state.

Unsuccessful AMA

- The frequency converter enters into alarm mode. A description of the alarm can be found in *chapter 7 Diagnostics and Troubleshooting*.
- Report value in the alarm log shows the last measuring sequence carried out by the AMA before the frequency converter entered alarm mode. This number, along with the description of the alarm, helps with troubleshooting. Mention the number and alarm description when contacting Danfoss service personnel.

Unsuccessful AMA is the result of incorrectly registered motor nameplate data or too large a difference between the motor power size and the frequency converter power size.

Set up the desired limits for speed and ramp time

Minimum reference	<i>Parameter 3-02 Minimum Reference</i>
Maximum reference	<i>Parameter 3-03 Maximum Reference</i>

Table 4.12 Reference Parameters

Motor speed low limit	<i>Parameter 4-11 Motor Speed Low Limit [RPM] or parameter 4-12 Motor Speed Low Limit [Hz]</i>
Motor speed high limit	<i>Parameter 4-13 Motor Speed High Limit [RPM] or parameter 4-14 Motor Speed High Limit [Hz]</i>

Table 4.13 Speed Limits

Ramp-up time 1 [s]	<i>Parameter 3-41 Ramp 1 Ramp Up Time</i>
Ramp-down time 1 [s]	<i>Parameter 3-42 Ramp 1 Ramp Down Time</i>

Table 4.14 Ramp Times

4.11 F-frame Options

Space heaters and thermostat

There are space heaters mounted on the cabinet interior of F-frame frequency converters. These heaters are controlled by an automatic thermostat and help control humidity inside the enclosure. The thermostat default settings turn on the heaters at 10 °C (50 °F) and turn them off at 15.6 °C (60 °F).

Cabinet light with power outlet

A light mounted on the cabinet interior of F-frame frequency converters increases visibility during servicing and maintenance. The housing includes a power outlet for temporarily powering tools or other devices, available in 2 voltages:

- 230 V, 50 Hz, 2.5 A, CE/ENEC
- 120 V, 60 Hz, 5 A, UL/cUL

Transformer tap set-up

If the cabinet light, outlet, and/or the space heaters, and thermostat are installed, transformer T1 requires its taps to be set to the proper input voltage. A 380–480/500 V frequency converter is initially set to the 525 V tap to ensure that no overvoltage of secondary equipment occurs if the tap is not changed before applying power. See *Table 4.15* to set the proper tap at terminal T1 located in the rectifier cabinet.

Input voltage range [V]	Tap to select [V]
380–440	400
441–500	460

Table 4.15 Transformer Tap Set-up

NAMUR terminals

NAMUR is an international association of automation technology users in the process industries, primarily chemical and pharmaceutical industries in Germany. Selecting this option, provides terminals organised and labeled to the specifications of the NAMUR standard for frequency converters input and output terminals. This requires VLT® PTC Thermistor Card MCB 112 and VLT® Extended Relay Card MCB 113.

RCD (residual current device)

Uses the core balance method to monitor ground fault currents in grounded and high-resistance grounded systems (TN and TT systems in IEC terminology). There is a pre-warning (50% of main alarm set-point) and a main alarm set-point. Associated with each set-point is an SPDT alarm relay for external use. Requires an external window-type current transformer (supplied and installed by the customer).

- Integrated into the frequency converter safe torque off circuit.
- IEC 60755 Type B device monitors AC, pulsed DC, and pure DC ground fault currents.
- LED bar graph indicator of the ground fault current level from 10–100% of the setpoint.
- Fault memory.
- TEST/RESET key.

Insulation resistance monitor (IRM)

Monitors the insulation resistance in ungrounded systems (IT systems in IEC terminology) between the system phase conductors and ground. There is an ohmic pre-warning and a main alarm setpoint for the insulation level. An SPDT

alarm relay for external use is associated with each setpoint.

NOTICE

Only 1 insulation resistance monitor can be connected to each ungrounded (IT) system.

- Integrated into the frequency converter Safe Torque Off circuit.
- LCD display of the ohmic value of the insulation resistance.
- Fault memory.
- INFO, TEST, and RESET keys.

IEC emergency stop with Pilz safety relay

Includes a redundant 4-wire emergency-stop push button mounted on the front of the enclosure and a Pilz relay that monitors it in conjunction with the frequency converter STO (Safe Torque Off) circuit and the mains contactor located in the options cabinet.

Manual motor starters

Provide 3-phase power for electric blowers often required for larger motors. Power for the starters is provided from the load side of any supplied contactor, circuit breaker, or disconnect switch. Power is fused before each motor starter, and is off when the incoming power to the frequency converters is off. Up to 2 starters are allowed (1 if a 30 A, fuse-protected circuit is ordered), and are integrated into the frequency converter STO circuit.

Unit features include:

- Operation switch (on/off).
- Short-circuit and overload protection with test function.
- Manual reset function.

30 A, fuse-protected terminals

- 3-phase power matching incoming mains voltage for powering auxiliary customer equipment.
- Not available if 2 manual motor starters are selected.
- Terminals are off when the incoming power to the frequency converter is off.
- Power for the fused protected terminals is provided from the load side of any supplied contactor, circuit breaker, or disconnect switch.

In applications where the motor is used as a brake, energy is generated in the motor and sent back into the frequency converter. If the energy cannot be transported back to the motor, it increases the voltage in the frequency converter DC line. In applications with frequent braking and/or high inertia loads, this increase may lead to an overvoltage trip in the frequency converter and finally a shut down. Brake resistors are used to dissipate the excess energy resulting from the regenerative braking. The resistor

is selected based on its ohmic value, its power dissipation rate, and its physical size. Danfoss offers a wide variety of different resistors that are specifically designed for Danfoss frequency converters.

5 Commissioning

5.1 Safety Instructions

See *chapter 2 Safety* for general safety instructions.

⚠ WARNING

HIGH VOLTAGE

Frequency converters contain high voltage when connected to AC mains input power. Failure to perform installation, start-up, and maintenance by qualified personnel could result in death or serious injury.

- Installation, start-up, and maintenance must be performed by qualified personnel only.

Before applying power:

1. Close the cover properly.
2. Check that all cable glands are firmly tightened.
3. Ensure that input power to the unit is OFF and locked out. Do not rely on the frequency

converter disconnect switches for input power isolation.

4. Verify that there is no voltage on input terminals L1 (91), L2 (92), and L3 (93), phase-to-phase, and phase-to-ground.
5. Verify that there is no voltage on output terminals 96 (U), 97 (V), and 98 (W), phase-to-phase, and phase-to-ground.
6. Confirm continuity of the motor by measuring Ω values on U-V (96-97), V-W (97-98), and W-U (98-96).
7. Check for proper grounding of the frequency converter as well as the motor.
8. Inspect the frequency converter for loose connections on the terminals.
9. Confirm that the supply voltage matches the voltage of the frequency converter and the motor.

5.1.1 Pre-start

⚠ CAUTION

Before applying power to the unit, inspect the entire installation as detailed in *Table 5.1*. Check mark those items when completed.

Inspect for	Description	<input checked="" type="checkbox"/>
Auxiliary equipment	<ul style="list-style-type: none"> • Look for auxiliary equipment, switches, disconnects, or input fuses/circuit breakers on the input power side of the frequency converter or output side to the motor. Ensure that they are ready for full speed operation. • Check function and installation of any sensors used for feedback to the frequency converter. • Remove power factor correction capacitors on motors, if present. 	
Cable routing	<ul style="list-style-type: none"> • Use separate metallic conduits for each of the following: <ul style="list-style-type: none"> - Input power - Motor wiring - Control wiring 	
Control wiring	<ul style="list-style-type: none"> • Check for broken or damaged wires and loose connections. • Check that control wiring is isolated from power and motor wiring for noise immunity. • Check the voltage source of the signals. • Use screened or twisted pair cable. Ensure that the screen is terminated correctly. 	
Cooling clearance	<ul style="list-style-type: none"> • Measure that top and bottom clearance is adequate to ensure proper air flow for cooling. 	
EMC considerations	<ul style="list-style-type: none"> • Check for proper installation regarding electromagnetic compatibility. 	
Environmental considerations	<ul style="list-style-type: none"> • See equipment label for the maximum ambient operating temperature limits. • Humidity levels must be 5–95%, non-condensing. 	

Inspect for	Description	☑
Fusing and circuit breakers	<ul style="list-style-type: none"> • Check for proper fusing or circuit breakers. • Check that all fuses are inserted firmly and in operational condition, and that all circuit breakers are in the open position. 	
Grounding	<ul style="list-style-type: none"> • The unit requires a ground wire from its enclosure to the building ground. • Check for good ground connections that are tight and free of oxidation. • Grounding to conduit or mounting the back panel to a metal surface is not sufficient. 	
Input and output power wiring	<ul style="list-style-type: none"> • Check for loose connections. • Check that motor and mains are in separate conduit or separated screened cables. 	
Panel interior	<ul style="list-style-type: none"> • Inspect that the unit interior is free of debris and corrosion. 	
Switches	<ul style="list-style-type: none"> • Ensure that all switch and disconnect settings are in the proper positions. 	
Vibration	<ul style="list-style-type: none"> • Check that the unit is mounted solidly or that shock mounts are used as necessary. • Check for an unusual amount of vibration. 	

Table 5.1 Start-up Checklist

5.2 Applying Power

WARNING

HIGH VOLTAGE!

Frequency converters contain high voltage when connected to AC mains. Installation, start-up, and maintenance should be performed by qualified personnel only. Failure to comply could result in death or serious injury.

WARNING

UNINTENDED START!

When the frequency converter is connected to AC mains, the motor may start at any time. The frequency converter, motor, and any driven equipment must be in operational readiness. Failure to comply could result in death, serious injury, equipment, or property damage.

1. Confirm that the input voltage is balanced within 3%. If not, correct input voltage imbalance before proceeding.
2. Ensure that optional equipment wiring, if present, matches the installation application.
3. Ensure that all operator devices are off. Panel doors should be closed or cover mounted.
4. Apply power to the unit. Do not start the frequency converter at this time. For units with a disconnect switch, turn the switch on to apply power.

NOTICE

If the status line at the bottom of the LCP reads **AUTO REMOTE COASTING** or **Alarm 60 External Interlock** is displayed, the unit is ready to operate but is missing an input signal on terminal 27.

5.3 Local Control Panel Operation

5.3.1 Local Control Panel

The local control panel (LCP) is the combined display and keypad on the front of the unit. The low harmonic drive includes 2 LCPs: 1 to control the frequency converter side and 1 to control the filter side.

The LCP has several functions:

- Control speed of frequency converter when in local mode.
- Start and stop in local mode.
- Display operational data, status, warnings, and alarms.

- Programme frequency converter and active filter functions.
- Manually reset the frequency converter or active filter after a fault when auto-reset is inactive.

NOTICE

For commissioning via PC, install the MCT 10 Set-up Software. The software is available for download (basic version) or for ordering (advanced version, order number 130B1000). For more information and downloads, see www.danfoss.com/BusinessAreas/DrivesSolutions/Software+MCT10/MCT10+Downloads.htm.

5.3.2 LCP Layout

The LCP is divided into 4 functional groups (see *Illustration 5.1*).

- A. Display area
- B. Display menu keys
- C. Navigation keys and indicator lights (LEDs)
- D. Operation keys and reset

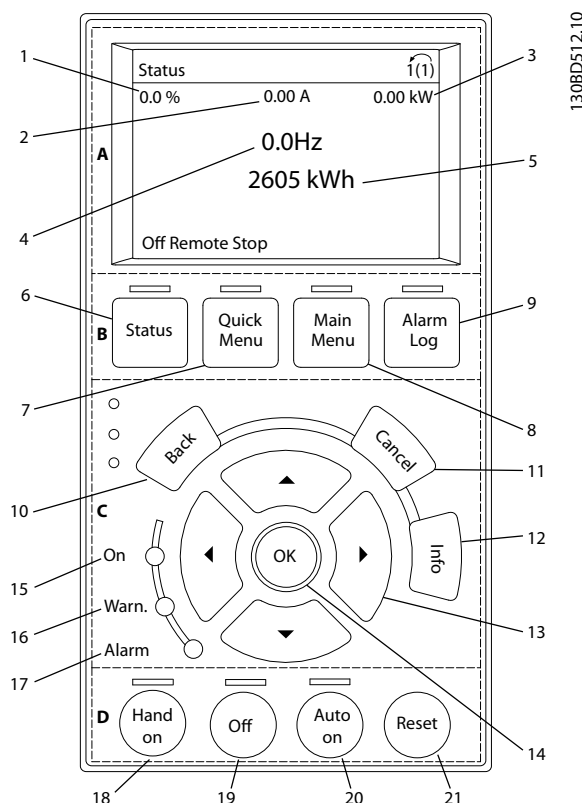

Illustration 5.1 Local Control Panel (LCP)

A. Display area

The display area is activated when the frequency converter receives power from mains voltage, a DC bus terminal, or an external 24 V DC supply.

The information displayed on the LCP can be customised for user application. Select options in the *Quick Menu Q3-13 Display Settings*.

Callout	Display	Parameter number	Default setting
1	1.1	0-20	Reference %
2	1.2	0-21	Motor current
3	1.3	0-22	Power [kW]
4	2	0-23	Frequency
5	3	0-24	kWh counter

Table 5.2 Legend to *Illustration 5.1, Display Area (Frequency Converter Side)*

B. Display menu keys

Menu keys are used for menu access for parameter set-up, toggling through status display modes during normal operation, and viewing fault log data.

Callout	Key	Function
6	Status	Shows operational information.
7	Quick Menu	Allows access to programming parameters for initial set-up instructions and many detailed application instructions.
8	Main Menu	Allows access to all programming parameters.
9	Alarm Log	Displays a list of current warnings, the last 10 alarms, and the maintenance log.

Table 5.3 Legend to *Illustration 5.1, Display Menu Keys*

C. Navigation keys and indicator lights (LEDs)

Navigation keys are used for programming functions and moving the display cursor. The navigation keys also provide speed control in local (hand) operation. There are also 3 frequency converter status indicator lights in this area.

Callout	Key	Function
10	Back	Reverts to the previous step or list in the menu structure.
11	Cancel	Cancels the last change or command as long as the display mode has not changed.
12	Info	Press for a definition of the function being displayed.
13	Navigation keys	Press to move between items in the menu.
14	OK	Press to access parameter groups or to enable an option.

Table 5.4 Legend to *Illustration 5.1, Navigation Keys*

Callout	Indicator	Light	Function
15	ON	Green	The ON light activates when the frequency converter receives power from mains voltage, a DC bus terminal, or an external 24 V supply.
16	WARN	Yellow	When a warning is issued, the yellow WARN light comes on and text appears in the display area identifying the problem.
17	ALARM	Red	A fault condition causes the red alarm light to flash and an alarm text is displayed.

Table 5.5 Legend to *Illustration 5.1, Indicator Lights (LEDs)*

D. Operation keys and reset

Operation keys are located at the bottom of the LCP.

Callout	Key	Function
18	Hand On	Starts the frequency converter in local control. <ul style="list-style-type: none"> An external stop signal by control input or serial communication overrides the local hand on.
19	Off	Stops the operation but does not remove power to the frequency converter.
20	Auto On	Puts the system in remote operational mode. <ul style="list-style-type: none"> Responds to an external start command by control terminals or serial communication.
21	Reset	Resets the frequency converter or active filter manually after a fault has been cleared.

Table 5.6 Legend to *Illustration 5.1, Operation Keys and Reset*

NOTICE

The display contrast can be adjusted by pressing [Status] and [▲]/[▼] keys.

5.3.3 Parameter Settings

Establishing the correct programming for applications often requires setting functions in several related parameters.

Programming data are stored internally in the frequency converter.

- For back-up, upload data into the LCP memory.
- To download data to another frequency converter, connect the LCP to that unit and download the stored settings.
- Restoring factory default settings does not change data stored in the LCP memory.

5.3.4 Uploading/Downloading Data to/from the LCP

1. Press [Off] to stop operation before uploading or downloading data.
2. Press [Main Menu] *parameter 0-50 LCP Copy* and press [OK].
3. Select [1] *All to LCP* to upload data to the LCP or select [2] *All from LCP* to download data from the LCP.
4. Press [OK]. A progress bar shows the uploading or downloading progress.
5. Press [Hand On] or [Auto On] to return to normal operation.

5.3.5 Changing Parameter Settings

Parameter settings can be accessed and changed from the *Quick Menu* or from the *Main Menu*. The *Quick Menu* only gives access to a limited number of parameters.

1. Press [Quick Menu] or [Main Menu] on the LCP.
2. Press [▲] [▼] to browse through the parameter groups, press [OK] to select a parameter group.
3. Press [▲] [▼] to browse through the parameters, press [OK] to select a parameter.
4. Press [▲] [▼] to change the value of a parameter setting.
5. Press [◀] [▶] to shift digit when a decimal parameter is in the editing state.
6. Press [OK] to accept the change.
7. Press either [Back] twice to enter *Status*, or press [Main Menu] once to enter the *Main Menu*.

View changes

Quick Menu Q5 - Changes Made lists all parameters changed from default settings.

- The list only shows parameters, which have been changed in the current edit set-up.
- Parameters, which have been reset to default values, are not listed.
- The message *Empty* indicates that no parameters have been changed.

5.3.6 Restoring Default Settings

NOTICE

Risk of losing programming and monitoring records by restoration of default settings. To provide a back-up, upload data to the LCP before initialisation.

Restoring the default parameter settings is done by initialisation of the frequency converter. Initialisation is carried out through *parameter 14-22 Operation Mode* (recommended) or manually.

- Initialisation using *parameter 14-22 Operation Mode* does not reset frequency converter settings, such as operating hours, serial communication selections, personal menu settings, fault log, alarm log, and other monitoring functions.
- Manual initialisation erases all motor, programming, localisation, and monitoring data, and restores factory default settings.

Recommended initialisation procedure, via *parameter 14-22 Operation Mode*

1. Press [Main Menu] twice to access parameters.
2. Scroll to *parameter 14-22 Operation Mode* and press [OK].
3. Scroll to [2] *Initialisation* and press [OK].
4. Remove power to the unit and wait for the display to turn off.
5. Apply power to the unit.

Default parameter settings are restored during start-up. This may take slightly longer than normal.

6. Alarm 80 is displayed.
7. Press [Reset] to return to operation mode.

Manual initialisation procedure

1. Remove power to the unit and wait for the display to turn off.
2. Press and hold [Status], [Main Menu], and [OK] at the same time while applying power to the unit (approximately 5 s or until audible click and fan starts).

Factory default parameter settings are restored during start-up. This may take slightly longer than normal.

Manual initialisation does not reset the following frequency converter information:

- *Parameter 15-00 Operating hours*
- *Parameter 15-03 Power Up's*
- *Parameter 15-04 Over Temp's*
- *Parameter 15-05 Over Volt's*

5.4 Basic Operational Programming

5.4.1 VLT® Low Harmonic Drive Programming

The low harmonic drive includes 2 LCPs: 1 to control the frequency converter side and 1 to control the filter side. Because of this unique design, the detailed parameter information for the product is found in 2 places.

Detailed programming information for the frequency converter portion can be found in the relevant *programming guide*. Detailed programming information for the filter can be found in the *VLT® Active Filter AAF 006 Operating Instructions*.

The remaining sections in this chapter apply to the frequency converter side. The active filter of the low harmonic drives is pre-configured for optimal performance and must only be turned on by pressing its [Hand On] key after the frequency converter side is commissioned.

5.4.2 Commissioning with SmartStart

The SmartStart wizard enables fast configuration of basic motor and application parameters.

- SmartStart starts automatically at first power-up or after initialisation of the frequency converter.
- Follow the on-screen instructions to complete the commissioning of the frequency converter. Always reactivate SmartStart by selecting *Quick Menu Q4 - SmartStart*.
- For commissioning without use of the SmartStart wizard, refer to *chapter 5.4.3 Commissioning via [Main Menu]* or the programming guide.

NOTICE

Motor data is required for the SmartStart set-up. The required data is normally available on the motor nameplate.

5.4.3 Commissioning via [Main Menu]

Recommended parameter settings are intended for start-up and check-out purposes. Application settings may vary.

Enter data with power ON, but before operating the frequency converter.

1. Press [Main Menu] on the LCP.
2. Press the navigation keys to scroll to parameter group 0-** Operation/Display and press [OK].

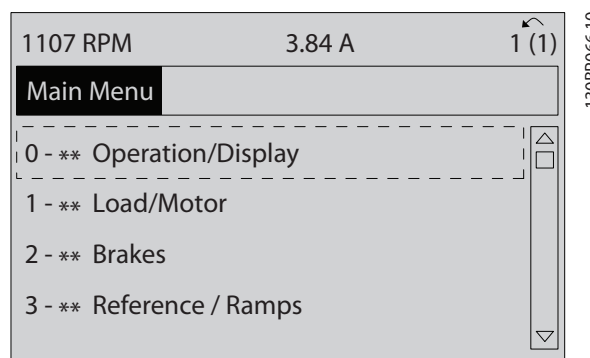

Illustration 5.2 Main Menu

3. Press the navigation keys to scroll to parameter group 0-0* Basic Settings and press [OK].

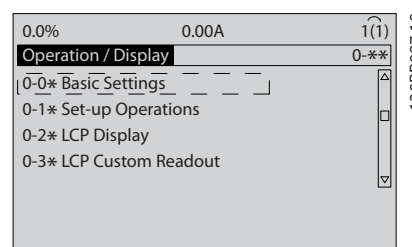

Illustration 5.3 Operation/Display

4. Press the navigation keys to scroll to parameter 0-03 Regional Settings and press [OK].

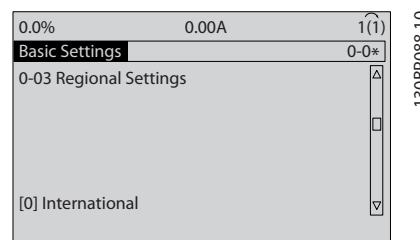

Illustration 5.4 Basic Settings

5. Press the navigation keys to select [0] International or [1] North America as appropriate and press [OK]. (This changes the default settings for a number of basic parameters).
6. Press [Main Menu] on the LCP.
7. Press the navigation keys to scroll to parameter 0-01 Language.
8. Select the language and press [OK].
9. If a jumper wire is in place between control terminals 12 and 27, leave parameter 5-12 Terminal 27 Digital Input at factory default. Otherwise, select No Operation in parameter 5-12 Terminal 27 Digital Input.

10. Make the application-specific settings in the following parameters:
 - 10a *Parameter 3-02 Minimum Reference.*
 - 10b *Parameter 3-03 Maximum Reference.*
 - 10c *Parameter 3-41 Ramp 1 Ramp Up Time.*
 - 10d *Parameter 3-42 Ramp 1 Ramp Down Time.*
 - 10e *Parameter 3-13 Reference Site.* Linked to Hand/Auto Local Remote.

5

5.4.4 Asynchronous Motor Set-up

Enter the following motor data. The information can be found on the motor nameplate.

1. *Parameter 1-20 Motor Power [kW] or parameter 1-21 Motor Power [HP].*
2. *Parameter 1-22 Motor Voltage.*
3. *Parameter 1-23 Motor Frequency.*
4. *Parameter 1-24 Motor Current.*
5. *Parameter 1-25 Motor Nominal Speed.*

When running in flux mode, or for optimum performance in VVC+ mode, extra motor data is required to set up the following parameters. The data can be found in the motor datasheet (this data is typically not available on the motor nameplate). Run a complete AMA using *parameter 1-29 Automatic Motor Adaptation (AMA) [1] Enable Complete AMA* or enter the parameters manually. *Parameter 1-36 Iron Loss Resistance (Rfe)* is always entered manually.

1. *Parameter 1-30 Stator Resistance (Rs).*
2. *Parameter 1-31 Rotor Resistance (Rr).*
3. *Parameter 1-33 Stator Leakage Reactance (X1).*
4. *Parameter 1-34 Rotor Leakage Reactance (X2).*
5. *Parameter 1-35 Main Reactance (Xh).*
6. *Parameter 1-36 Iron Loss Resistance (Rfe).*

Application-specific adjustment when running VVC+

VVC+ is the most robust control mode. In most situations, it provides optimum performance without further adjustments. Run a complete AMA for best performance.

Application-specific adjustment when running Flux

Flux mode is the preferred control mode for optimum shaft performance in dynamic applications. Perform an AMA since this control mode requires precise motor data. Depending on the application, further adjustments may be required.

See *Table 5.7* for application-related recommendations.

Application	Settings
Low-inertia applications	Keep calculated values.
High-inertia applications	<i>Parameter 1-66 Min. Current at Low Speed.</i> Increase current to a value between default and maximum depending on the application. Set ramp times matching the application. Too fast ramp up causes an overcurrent or overtorque. Too fast ramp down causes an overvoltage trip.
High load at low speed	<i>Parameter 1-66 Min. Current at Low Speed.</i> Increase current to a value between default and maximum depending on the application.
No-load application	Adjust <i>parameter 1-18 Min. Current at No Load</i> to achieve smoother motor operation by reducing torque ripple and vibration.
Flux sensorless only	Adjust <i>parameter 1-53 Model Shift Frequency.</i> Example 1: If the motor oscillates at 5 Hz and dynamics performance is required at 15 Hz, set <i>parameter 1-53 Model Shift Frequency</i> to 10 Hz. Example 2: If the application involves dynamic load changes at low speed, reduce <i>parameter 1-53 Model Shift Frequency.</i> Observe the motor behaviour to make sure that the model shift frequency is not reduced too much. Symptoms of inappropriate model shift frequency are motor oscillations or frequency converter tripping.

Table 5.7 Recommendations for Flux Applications

5.4.5 Permanent Magnet Motor Set-up

NOTICE

Only use permanent magnet (PM) motor with fans and pumps.

Initial programming steps

1. Activate PM motor operation in *parameter 1-10 Motor Construction*, select [1] PM, non-salient SPM.
2. Set *parameter 0-02 Motor Speed Unit* to [0] RPM.

Programming motor data

After selecting *PM motor* in *parameter 1-10 Motor Construction*, the PM motor-related parameters in parameter groups *1-2* Motor Data*, *1-3* Adv. Motor Data*, and *1-4** are active.

Find the necessary data on the motor nameplate and in the motor data sheet.

Program the following parameters in the listed order:

1. *Parameter 1-24 Motor Current.*
2. *Parameter 1-26 Motor Cont. Rated Torque.*
3. *Parameter 1-25 Motor Nominal Speed.*
4. *Parameter 1-39 Motor Poles.*
5. *Parameter 1-30 Stator Resistance (Rs).*
Enter line to common stator winding resistance (Rs). If only line-line data are available, divide the line-line value with 2 to achieve the line to common (starpoint) value.
It is also possible to measure the value with an ohmmeter, which takes the resistance of the cable into account. Divide the measured value by 2 and enter the result.
6. *Parameter 1-37 d-axis Inductance (Ld).*
Enter line to common direct axis inductance of the PM motor.
If only line-line data are available, divide the line-line value with 2 to achieve the line-common (starpoint) value.
It is also possible to measure the value with an inductancemeter, which takes the inductance of the cable into account. Divide the measured value by 2 and enter the result.
7. *Parameter 1-40 Back EMF at 1000 RPM*
Enter line-line back EMF of PM Motor at 1000 RPM mechanical speed (RMS value). Back EMF is the voltage generated by a PM motor when no frequency converter is connected and the shaft is turned externally. Back EMF is normally specified for nominal motor speed or for 1000 RPM measured between 2 lines. If the value is not available for a motor speed of 1000 RPM, calculate the correct value as follows: If back EMF is for example 320 V at 1800 RPM, it can be calculated at 1000 RPM as follows: Back EMF = (Voltage/RPM)x1000 = (320/1800)x1000 = 178. Program this value for *parameter 1-40 Back EMF at 1000 RPM*.

Test motor operation

1. Start the motor at low speed (100–200 RPM). If the motor does not turn, check installation, general programming, and motor data.
2. Check if start function in *parameter 1-70 PM Start Mode* fits the application requirements.

Rotor detection

This function is the recommended choice for applications where the motor starts from standstill, for example pumps or conveyors. On some motors, a sound is heard when the impulse is sent out. This does not harm the motor.

Parking

This function is the recommended choice for applications where the motor is rotating at slow speed for example windmilling in fan applications. *Parameter 2-06 Parking Current* and *parameter 2-07 Parking Time* can be adjusted. Increase the factory setting of these parameters for applications with high inertia.

Start the motor at nominal speed. If the application does not run well, check the VVC+ PM settings. *Table 5.7* shows recommendations in different applications.

Application	Settings
Low-inertia applications $I_{Load}/I_{Motor} < 5$	Increase <i>parameter 1-17 Voltage filter time const.</i> by factor 5–10 Reduce <i>parameter 1-14 Damping Gain</i> . Reduce <i>parameter 1-66 Min. Current at Low Speed (<100%)</i> .
Low-inertia applications $50 > I_{Load}/I_{Motor} > 5$	Keep the calculated values.
High-inertia applications $I_{Load}/I_{Motor} > 50$	Increase <i>parameter 1-14 Damping Gain</i> , <i>parameter 1-15 Low Speed Filter Time Const.</i> , and <i>parameter 1-16 High Speed Filter Time Const.</i> .
High load at low speed <30% (rated speed)	Increase <i>parameter 1-17 Voltage filter time const.</i> . Increase <i>parameter 1-66 Min. Current at Low Speed (>100%</i> for a prolonged time can overheat the motor).

Table 5.8 Recommendations in Different Applications

If the motor starts oscillating at a certain speed, increase *parameter 1-14 Damping Gain*. Increase the value in small steps. Depending on the motor, a good value for this parameter can be 10% or 100% higher than the default value.

Starting torque can be adjusted in *parameter 1-66 Min. Current at Low Speed*. 100% provides nominal torque as starting torque.

5.4.6 Automatic Energy Optimisation (AEO)

NOTICE

AEO is not relevant for permanent magnet motors.

AEO is a procedure which minimises voltage to the motor, thereby reducing energy consumption, heat, and noise.

To activate AEO, set *parameter 1-03 Torque Characteristics* to [2] *Auto Energy Optim. CT* or [3] *Auto Energy Optim. VT*.

5.4.7 Automatic Motor Adaptation (AMA)

AMA is a procedure which optimises compatibility between the frequency converter and the motor.

- The frequency converter builds a mathematical model of the motor for regulating output motor current. The procedure also tests the input phase balance of electrical power. It compares the motor characteristics with the entered nameplate data.
- The motor shaft does not turn and no harm is done to the motor while running the AMA.
- Some motors may be unable to run the complete version of the test. In that case, select [2] *Enable reduced AMA*.
- If an output filter is connected to the motor, select [2] *Enable reduced AMA*.
- If warnings or alarms occur, see *chapter 7 Diagnostics and Troubleshooting*.
- Run this procedure on a cold motor for best results.

To run AMA

1. Press [Main Menu] to access parameters.
2. Scroll to parameter group 1-** *Load and Motor* and press [OK].
3. Scroll to parameter group 1-2* *Motor Data* and press [OK].
4. Scroll to *parameter 1-29 Automatic Motor Adaptation (AMA)* and press [OK].
5. Select [1] *Enable complete AMA* and press [OK].
6. Follow the on-screen instructions.
7. The test runs automatically and indicates when it is complete.
8. The advanced motor data is entered in parameter group 1-3* *Adv. Motor Data*.

5.5 Checking Motor Rotation

NOTICE

Risk of damage to pumps/compressors caused by motor running in wrong direction. Before running the frequency converter, check the motor rotation.

The motor runs briefly at 5 Hz or the minimum frequency set in *parameter 4-12 Motor Speed Low Limit [Hz]*.

1. Press [Main Menu].
2. Scroll to *parameter 1-28 Motor Rotation Check* and press [OK].
3. Scroll to [1] *Enable*.

The following text appears: *Note! Motor may run in wrong direction.*

4. Press [OK].
5. Follow the on-screen instructions.

NOTICE

To change the direction of rotation, remove power to the frequency converter and wait for power to discharge. Reverse the connection of any 2 of the 3 motor wires on the motor or frequency converter side of the connection.

5.6 Local Control Test

1. Press [Hand On] to provide a local start command to the frequency converter.
2. Accelerate the frequency converter by pressing [▲] to full speed. Moving the cursor left of the decimal point provides quicker input changes.
3. Note any acceleration problems.
4. Press [Off]. Note any deceleration problems.

In the event of acceleration or deceleration problems, see *chapter 7.5 Troubleshooting*. See *chapter 7.3 Warnings and Alarm Definitions - Frequency Converter* for resetting the frequency converter after a trip.

5.7 System Start-up

The procedure in this section requires wiring and application programming to be completed. The following procedure is recommended after application set-up is completed.

1. Press [Auto On].
2. Apply an external run command.
3. Adjust the speed reference throughout the speed range.
4. Remove the external run command.
5. Check the sound and vibration levels of the motor to ensure that the system is working as intended.

If warnings or alarms occur, see *chapter 7.3 Warnings and Alarm Definitions - Frequency Converter* or *chapter 7.4 Warnings and Alarm Definitions - Active Filter*.

6 Application Examples

6.1 Introduction

The examples in this section are intended as a quick reference for common applications.

- Parameter settings are the regional default values unless otherwise indicated (selected in *parameter 0-03 Regional Settings*).
- Parameters associated with the terminals and their settings are shown next to the drawings.
- Required switch settings for analog terminals A53 or A54 are also shown.

NOTICE

When using the optional STO feature, a jumper wire may be required between terminal 12 (or 13) and terminal 37 for the frequency converter to operate with factory default programming values.

NOTICE

The following examples refer only to the frequency converter control card (right LCP), *not* the filter.

6.2 Application Examples

CAUTION

Thermistors must use reinforced or double insulation to meet PELV insulation requirements.

		Parameters	
FC		Function	Setting
+24 V	12	Parameter 1-29 Automatic Motor Adaptation (AMA)	[1] Enable complete AMA
+24 V	13		
D IN	18	Parameter 5-12 Terminal 27 Digital Input	[2]* Coast inverse
D IN	19		
COM	20	*=Default value	
D IN	27	Notes/comments: Parameter group 1-2* Motor Data must be set according to motor	
D IN	29		
D IN	32		
D IN	33		
D IN	37		
+10 V	50		
A IN	53		
A IN	54		
COM	55		
A OUT	42		
COM	39		

Table 6.1 AMA with T27 Connected

		Parameters	
FC		Function	Setting
+24 V	12	Parameter 1-29 Automatic Motor Adaptation (AMA)	[1] Enable complete AMA
+24 V	13		
D IN	18	Parameter 5-12 Terminal 27 Digital Input	[0] No operation
D IN	19		
COM	20	*=Default value	
D IN	27	Notes/comments: Parameter group 1-2* Motor Data must be set according to motor	
D IN	29		
D IN	32		
D IN	33		
D IN	37		
+10 V	50		
A IN	53		
A IN	54		
COM	55		
A OUT	42		
COM	39		

Table 6.2 AMA without T27 Connected

		Parameters	
FC		Function	Setting
+24 V	12	130BB926.10	Parameter 6-10 Terminal 53 Low Voltage
+24 V	13		0.07 V*
D IN	18		Parameter 6-11 Terminal 53 High Voltage
D IN	19		10 V*
COM	20		Parameter 6-14 Terminal 53 Low Ref./Feedb. Value
D IN	27		0 RPM
D IN	29		Parameter 6-15 Terminal 53 High Ref./Feedb. Value
D IN	32		1500 RPM
D IN	33		*=Default value
D IN	37		Notes/comments:
+10 V	50		
A IN	53		
A IN	54		
COM	55		
A OUT	42		
COM	39		
U - I			
A53			

Table 6.3 Analog Speed Reference (Voltage)

		Parameters	
FC		Function	Setting
+24 V	12	130BB927.10	Parameter 6-12 Terminal 53 Low Current
+24 V	13		4 mA*
D IN	18		Parameter 6-13 Terminal 53 High Current
D IN	19		20 mA*
COM	20		Parameter 6-14 Terminal 53 Low Ref./Feedb. Value
D IN	27		0 RPM
D IN	29		Parameter 6-15 Terminal 53 High Ref./Feedb. Value
D IN	32		1500 RPM
D IN	33		*=Default value
D IN	37		Notes/comments:
+10 V	50		
A IN	53		
A IN	54		
COM	55		
A OUT	42		
COM	39		
U - I			
A53			

Table 6.4 Analog Speed Reference (Current)

		Parameters	
FC		Function	Setting
+24 V	12	130BB802.10	Parameter 5-10 Terminal 18 Digital Input
+24 V	13		[8] Start*
D IN	18		Parameter 5-12 Terminal 27 Digital Input
D IN	19		[0] No operation
COM	20		Parameter 5-19 Terminal 37 Safe Stop
D IN	27		[1] Safe Stop Alarm
D IN	29		*=Default value
D IN	32		Notes/comments:
D IN	33		If parameter 5-12 Terminal 27 Digital Input is set to [0] No operation, a jumper wire to terminal 27 is not needed.
D IN	37		
+10 V	50		
A IN	53		
A IN	54		
COM	55		
A OUT	42		
COM	39		
U - I			
A53			

Table 6.5 Start/Stop Command with Safe Torque Off

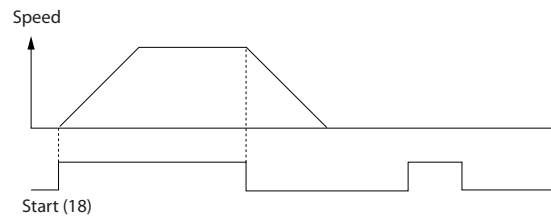

130BB805.11

Illustration 6.1 Start/Stop with Safe Torque Off

		Parameters	
FC		Function	Setting
+24 V	12	130BB803.10	Parameter 5-10 Terminal 18 Digital Input
+24 V	13		[9] Latched Start
D IN	18		Parameter 5-12 Terminal 27 Digital Input
D IN	19		[6] Stop Inverse
COM	20		*=Default value
D IN	27		Notes/comments:
D IN	29		If parameter 5-12 Terminal 27 Digital Input is set to [0] No operation, a jumper wire to terminal 27 is not needed.
D IN	32		
D IN	33		
D IN	37		
+10 V	50		
A IN	53		
A IN	54		
COM	55		
A OUT	42		
COM	39		
U - I			
A53			

Table 6.6 Pulse Start/Stop

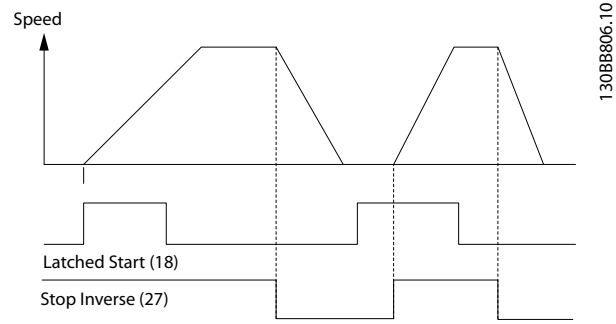

130BB806.10

Illustration 6.2 Latched Start/Stop Inverse

		Parameters	
FC		Function	Setting
+24 V	12	Parameter 5-10 Terminal 18 Digital Input	[8] Start
+24 V	13		
D IN	18	Parameter 5-11 Terminal 19 Digital Input	[10] Reversing*
D IN	19		
COM	20	Parameter 5-12 Terminal 27 Digital Input	[0] No operation
D IN	27		
D IN	29	Parameter 5-14 Terminal 32 Digital Input	[16] Preset ref bit 0
D IN	32		
D IN	33	Parameter 5-15 Terminal 33 Digital Input	[17] Preset ref bit 1
D IN	37		
+10 V	50	Parameter 3-10 Preset Reference	Preset ref. 0 25%
A IN	53		Preset ref. 1 50%
A IN	54		Preset ref. 2 75%
COM	55		Preset ref. 3 100%
A OUT	42	*=Default value	
COM	39	Notes/comments:	

Table 6.7 Start/Stop with Reversing and 4 Preset Speeds

		Parameters	
FC		Function	Setting
+24 V	12	Parameter 5-11 Terminal 19 Digital Input	[1] Reset
+24 V	13		
D IN	18	*=Default value	
D IN	19		
COM	20	Notes/comments:	
D IN	27		
D IN	29		
D IN	32		
D IN	33		
D IN	37		
+10 V	50		
A IN	53		
A IN	54		
COM	55		
A OUT	42		
COM	39		

Table 6.8 External Alarm Reset

		Parameters	
FC		Function	Setting
+24 V	12	Parameter 6-10 Terminal 53 Low Voltage	0.07 V*
+24 V	13		
D IN	18	Parameter 6-11 Terminal 53 High Voltage	10 V*
D IN	19		
COM	20	Parameter 6-14 Terminal 53 Low Ref./Feedb. Value	0 RPM
D IN	27		
D IN	29	Parameter 6-15 Terminal 53 High Ref./Feedb. Value	1500 RPM
D IN	32		
D IN	33	*=Default value	
D IN	37	Notes/comments:	
+10 V	50		
A IN	53		
A IN	54		
COM	55		
A OUT	42		
COM	39		

Table 6.9 Speed Reference (using a Manual Potentiometer)

		Parameters	
FC		Function	Setting
+24 V	12	Parameter 5-10 Terminal 18 Digital Input	[8] Start*
+24 V	13		
D IN	18	Parameter 5-12 Terminal 27 Digital Input	[19] Freeze Reference
D IN	19		
COM	20	Parameter 5-13 Terminal 29 Digital Input	[21] Speed Up
D IN	27		
D IN	29	Parameter 5-14 Terminal 32 Digital Input	[22] Speed Down
D IN	32		
D IN	33	*=Default value	
D IN	37	Notes/comments:	
+10 V	50		
A IN	53		
A IN	54		
COM	55		
A OUT	42		
COM	39		

Table 6.10 Speed Up/Down

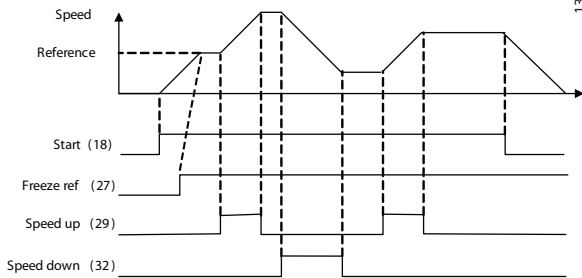

Illustration 6.3 Speed Up/Down

		Parameters	
FC		Function	Setting
+24 V	12	Parameter 8-30 Protocol	FC*
+24 V	13		
D IN	18	Parameter 8-31 Address	1*
D IN	19		
COM	20	Parameter 8-32 Baud Rate	9600*
D IN	27		
D IN	29	*=Default value	
D IN	32	Notes/comments:	
D IN	33	Select protocol, address, and Baud rate in the above-mentioned parameters.	
D IN	37		
+10 V	50		
A IN	53		
A IN	54		
COM	55		
A OUT	42		
COM	39		

Table 6.11 RS485 Network Connection

		Parameters	
VLT		Function	Setting
+24 V	12	Parameter 1-90 Motor Thermal Protection	[2] Thermistor trip
+24 V	13		
D IN	18	Parameter 1-93 Thermistor Source	[1] Analog input 53
D IN	19		
COM	20	*=Default value	
D IN	27	Notes/comments:	
D IN	29	If only a warning is desired, set parameter 1-90 Motor Thermal Protection to [1] Thermistor warning.	
D IN	32		
D IN	33		
D IN	37		
+10 V	50		
A IN	53		
A IN	54		
COM	55		
A OUT	42		
COM	39		

Table 6.12 Motor Thermistor

		Parameters		
FC		Function	Setting	
+24 V	12	Parameter 4-30 Motor Feedback Loss Function	[1] Warning	
+24 V	13			
D IN	18			
D IN	19		Parameter 4-31 Motor Feedback Speed Error	100 RPM
COM	20			
D IN	27			
D IN	29		Parameter 4-32 Motor Feedback Loss Timeout	5 s
D IN	32			
D IN	33			
D IN	37			
+10 V	50	Parameter 7-00 S peed PID Feedback Source	[2] MCB 102	
A IN	53			
A IN	54	Parameter 17-11 Resolution (PPR)	1024*	
COM	55			
A OUT	42	Parameter 13-00 SL Controller Mode	[1] On	
COM	39			
R1	01	Parameter 13-01 Start Event	[19] Warning	
	02			
	03	Parameter 13-02 Stop Event	[44] Reset key	
R2	04	Parameter 13-10 Comparator Operand	[21] Warning no.	
	05			
	06	Parameter 13-11 Comparator Operator	[1] ≈*	
		Parameter 13-12 Comparator Value	90	
		Parameter 13-51 SL Controller Event	[22] Comparator 0	
		Parameter 13-52 SL Controller Action	[32] Set digital out A low	
		Parameter 5-40 F unction Relay	[80] SL digital output A	
* = Default value				
Notes/comments:				
If the limit in the feedback monitor is exceeded, Warning 90 is issued. The SLC monitors the warning and in the case that it becomes TRUE, relay 1 is triggered.				
External equipment may indicate that service is required. If the feedback error goes below the limit again within 5 s, the frequency converter continues and the warning disappears. But relay 1 is still triggered until pressing [Reset] on the LCP.				

		Parameters		
FC		Function	Setting	
+24 V	12	Parameter 1-00 C onfiguration Mode	[0] Speed open loop	
+24 V	13			
D IN	18			
D IN	19		Parameter 1-01 Motor Control Principle	[1] VVC+
COM	20			
D IN	27			
D IN	29		Parameter 5-40 F unction Relay	[32] Mech. brake ctrl.
D IN	32			
D IN	33		Parameter 5-10 T erminal 18 Digital Input	[8] Start*
D IN	37			
+10 V	50	Parameter 5-11 T erminal 19 Digital Input	[11] Start reversing	
A IN	53			
A IN	54			
COM	55			
A OUT	42	Parameter 1-71 S tart Delay	0.2	
COM	39	Parameter 1-72 S tart Function	[5] VVC+/ FLUX Clockwise	
R1	01	Parameter 1-76 S tart Current	I _{m,n}	
	02			
	03	Parameter 2-20 R elease Brake Current	App. dependent	
R2	04	Parameter 2-21 A ctivate Brake Speed [RPM]	Half of nominal slip of the motor	
	05			
	06			
* = Default value				
Notes/comments:				

Table 6.14 Mechanical Brake Control (Open Loop)

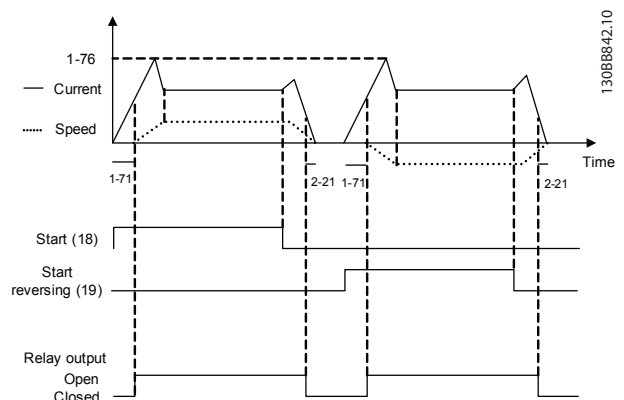

Illustration 6.4 Mechanical Brake Control (Open Loop)

Table 6.13 Using SLC to Set a Relay

7 Diagnostics and Troubleshooting

7.1 Status Messages

When the frequency converter is in *Status* mode, status messages are generated automatically and appear in the bottom line of the display (see *Illustration 7.1*). Refer to the *VLT® AutomationDrive FC 302 Programming Guide* for detailed descriptions of the displayed status messages.

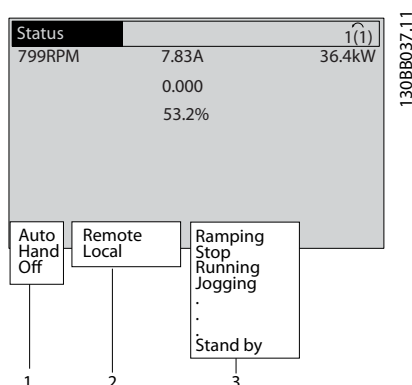

1	Operation mode
2	Reference site
3	Operation status

Illustration 7.1 Status Display

7.2 Warning and Alarm Types

The frequency converter monitors the condition of its input power, output, and motor factors, as well as other system performance indicators. A warning or alarm does not necessarily indicate a problem internally the frequency converter. In many cases, it indicates failure conditions from:

- Input voltage.
- Motor load.
- Motor temperature.
- External signals.
- Other areas monitored by internal logic.

Investigate as indicated in the alarm or warning.

7.2.1 Warnings

A warning is issued when an alarm condition is impending or when an abnormal operating condition is present and may result in the frequency converter issuing an alarm. A warning clears by itself when the abnormal condition is removed.

7.2.2 Alarm Trip

An alarm is issued when the frequency converter is tripped, that is, the frequency converter suspends operation to prevent frequency converter or system damage. The motor coasts to a stop, if the alarm trip is on the frequency converter side. The frequency converter logic continues to operate and monitors the frequency converter status. After the fault condition is remedied, reset the frequency converter. It is then ready to start operation again.

A trip can be reset in any of 4 ways:

- Press [Reset] on the LCP.
- Digital reset input command.
- Serial communication reset input command.
- Auto reset.

7.2.3 Alarm Trip-lock

An alarm that causes the frequency converter to trip-lock requires that input power is cycled. If the alarm trip is on the frequency converter side, the motor coasts to a stop. The frequency converter logic continues to operate and monitors the frequency converter status. Remove input power to the frequency converter and correct the cause of the fault, then restore power. This action puts the frequency converter into a trip condition as described in *chapter 7.2.2 Alarm Trip* and may be reset in any of the 4 ways.

7.3 Warnings and Alarm Definitions - Frequency Converter

The following warning/alarm information defines each warning/alarm condition, provides the probable cause for the condition, and details a remedy or troubleshooting procedure.

WARNING 1, 10 Volts low

The control card voltage is <10 V from terminal 50. Remove some of the load from terminal 50, as the 10 V supply is overloaded. Maximum 15 mA or minimum 590 Ω.

A short circuit in a connected potentiometer or incorrect wiring of the potentiometer can cause this condition.

Troubleshooting

- Remove the wiring from terminal 50. If the warning clears, the problem is with the wiring. If the warning does not clear, replace the control card.

WARNING/ALARM 2, Live zero error

This warning or alarm only appears if programmed in *parameter 6-01 Live Zero Timeout Function*. The signal on 1 of the analog inputs is less than 50% of the minimum value programmed for that input. Broken wiring or a faulty device sending the signal can cause this condition.

Troubleshooting

- Check the connections on all the analog mains terminals.
 - Control card terminals 53 and 54 for signals, terminal 55 common.
 - MCB 101 terminals 11 and 12 for signals, terminal 10 common.
 - MCB 109 terminals 1, 3, and 5 for signals, terminals 2, 4, and 6 common.
- Check that the frequency converter programming and switch settings match the analog signal type.
- Perform an input terminal signal test.

WARNING/ALARM 3, No motor

No motor has been connected to the output of the frequency converter.

WARNING/ALARM 4, Mains phase loss

A phase is missing on the supply side, or the mains voltage imbalance is too high. This message also appears for a fault in the input rectifier on the frequency converter. Options are programmed in *parameter 14-12 Function at Mains Imbalance*.

Troubleshooting

- Check the supply voltage and supply currents to the frequency converter.

WARNING 5, DC link voltage high

The DC-link voltage (DC) is higher than the high-voltage warning limit. The limit depends on the frequency converter voltage rating. The unit is still active.

WARNING 6, DC link voltage low

The DC-link voltage (DC) is lower than the low-voltage warning limit. The limit depends on the frequency converter voltage rating. The unit is still active.

WARNING/ALARM 7, DC overvoltage

If the DC-link voltage exceeds the limit, the frequency converter trips after a time.

Troubleshooting

- Connect a brake resistor.
- Extend the ramp time.
- Change the ramp type.
- Activate the functions in *parameter 2-10 Brake Function*.
- Increase *parameter 14-26 Trip Delay at Inverter Fault*.

- If the alarm/warning occurs during a power sag, use kinetic back-up (*parameter 14-10 Mains Failure*).

WARNING/ALARM 8, DC under voltage

If the DC-link voltage drops below the undervoltage limit, the frequency converter checks if a 24 V DC back-up supply is connected. If no 24 V DC back-up supply is connected, the frequency converter trips after a fixed time delay. The time delay varies with unit size.

Troubleshooting

- Check that the supply voltage matches the frequency converter voltage.
- Perform an input voltage test.
- Perform a soft charge circuit test.

WARNING/ALARM 9, Inverter overload

The frequency converter has run with more than 100% overload for too long and is about to cut-out. The counter for electronic thermal inverter protection issues a warning at 98% and trips at 100%, while giving an alarm. The frequency converter cannot be reset until the counter is below 90%.

Troubleshooting

- Compare the output current shown on the LCP with the frequency converter rated current.
- Compare the output current shown on the LCP with the measured motor current.
- Display the thermal frequency converter load on the LCP and monitor the value. When running above the frequency converter continuous current rating, the counter increases. When running below the frequency converter continuous current rating, the counter decreases.

WARNING/ALARM 10, Motor overload temperature

According to the electronic thermal protection (ETR), the motor is too hot. Select whether the frequency converter issues a warning or an alarm when the counter reaches 100% in *parameter 1-90 Motor Thermal Protection*. The fault occurs when the motor runs with more than 100% overload for too long.

Troubleshooting

- Check for motor overheating.
- Check if the motor is mechanically overloaded.
- Check that the motor current set in *parameter 1-24 Motor Current* is correct.
- Ensure that the motor data in *parameters 1-20 to 1-25* are set correctly.
- If an external fan is in use, check that it is selected in *parameter 1-91 Motor External Fan*.
- Running AMA in *parameter 1-29 Automatic Motor Adaptation (AMA)* tunes the frequency converter to the motor more accurately and reduces thermal loading.

WARNING/ALARM 11, Motor thermistor overtemp

The thermistor may be disconnected. Select whether the frequency converter issues a warning or an alarm in *parameter 1-90 Motor Thermal Protection*.

Troubleshooting

- Check for motor overheating.
- Check if the motor is mechanically overloaded.
- Check that the thermistor is connected correctly between either terminal 53 or 54 (analog voltage input) and terminal 50 (+10 V supply). Also check that the terminal switch for 53 or 54 is set for voltage. Check that *parameter 1-93 Thermistor Resource* is set to terminal 53 or 54.
- When using digital inputs 18 or 19, check that the thermistor is connected correctly between either terminal 18 or 19 (digital input PNP only) and terminal 50.
- If a KTY sensor is used, check for correct connection between terminals 54 and 55
- If using a thermal switch or thermistor, check that the programming of *parameter 1-93 Thermistor Resource* matches sensor wiring.
- If using a KTY Sensor, check the programming of *parameter 1-95 KTY Sensor Type*, *parameter 1-96 KTY Thermistor Resource* and *parameter 1-97 KTY Threshold level* match sensor wiring.

WARNING/ALARM 12, Torque limit

The torque has exceeded the value in *parameter 4-16 Torque Limit Motor Mode* or the value in *parameter 4-17 Torque Limit Generator Mode*. *Parameter 14-25 Trip Delay at Torque Limit* can change this warning from a warning-only condition to a warning followed by an alarm.

Troubleshooting

- If the motor torque limit is exceeded during ramp-up, extend the ramp-up time.
- If the generator torque limit is exceeded during ramp-down, extend the ramp-down time.
- If torque limit occurs while running, increase the torque limit. Make sure that the system can operate safely at a higher torque.
- Check the application for excessive current draw on the motor.

WARNING/ALARM 13, Over current

The inverter peak current limit (approximately 200% of the rated current) is exceeded. The warning lasts approximately 1.5 s, then the frequency converter trips and issues an alarm. Shock loading or quick acceleration with high-inertia loads can cause this fault. If the acceleration during ramp-up is quick, the fault can also appear after kinetic back-up. If extended mechanical brake control is selected, a trip can be reset externally.

Troubleshooting

- Remove the power and check if the motor shaft can be turned.
- Check that the motor size matches the frequency converter.
- Check that the motor data is correct in *parameters 1-20 to 1-25*.

ALARM 14, Earth (ground) fault

There is current from the output phases to ground, either in the cable between the frequency converter and the motor, or in the motor itself.

Troubleshooting

- Remove the power to the frequency converter and repair the ground fault.
- Check for ground faults in the motor by measuring the resistance to the ground of the motor cables and the motor with a megohmmeter.
- Perform a current sensor test.

ALARM 15, Hardware mismatch

A fitted option is not operational with the present control board hardware or software.

Record the value of the following parameters and contact Danfoss:

- *Parameter 15-40 FC Type*.
- *Parameter 15-41 Power Section*.
- *Parameter 15-42 Voltage*.
- *Parameter 15-43 Software Version*.
- *Parameter 15-45 Actual Typecode String*.
- *Parameter 15-49 SW ID Control Card*.
- *Parameter 15-50 SW ID Power Card*.
- *Parameter 15-60 Option Mounted*.
- *Parameter 15-61 Option SW Version* (for each option slot).

ALARM 16, Short circuit

There is short-circuiting in the motor or motor wiring.

Troubleshooting

- Remove the power to the frequency converter and repair the short circuit.

WARNING/ALARM 17, Control word timeout

There is no communication with the frequency converter. The warning is only active when *parameter 8-04 Control Word Timeout Function* is not set to [0] Off. If *parameter 8-04 Control Word Timeout Function* is set to [2] Stop and [26] Trip, a warning appears and the frequency converter ramps down until it trips and then displays an alarm.

Troubleshooting

- Check the connections on the serial communication cable.
- Increase *parameter 8-03 Control Word Timeout Time*
- Check the operation of the communication equipment.
- Verify a proper installation based on EMC requirements.

WARNING/ALARM 22, Hoist mechanical brake

Report value shows what kind it is.

0 = The torque reference was not reached before timeout (*parameter 2-27 Torque Ramp Up Time*).

1 = Expected brake feedback not received before timeout (*parameter 2-23 Activate Brake Delay, parameter 2-25 Brake Release Time*).

WARNING 23, Internal fan fault

The fan warning function is an extra protective function that checks if the fan is running/mounted. The fan warning can be disabled in *parameter 14-53 Fan Monitor ([0] Disabled)*.

Troubleshooting

- Check the fan resistance.
- Check the soft charge fuses.

WARNING 24, External fan fault

The fan warning function is an extra protective function that checks if the fan is running/mounted. The fan warning can be disabled in *parameter 14-53 Fan Monitor ([0] Disabled)*.

Troubleshooting

- Check the fan resistance.
- Check the soft charge fuses.

WARNING 25, Brake resistor short circuit

The brake resistor is monitored during operation. If a short circuit occurs, the brake function is disabled and the warning appears. The frequency converter is still operational, but without the brake function.

Troubleshooting

- Remove the power to the frequency converter and replace the brake resistor (see *parameter 2-15 Brake Check*).

WARNING/ALARM 26, Brake resistor power limit

The power transmitted to the brake resistor is calculated as a mean value over the last 120 s of run time. The calculation is based on the intermediate circuit voltage and the brake resistance value set in *parameter 2-16 AC brake Max. Current*. The warning is active when the dissipated braking is >90% of the brake resistance power. If [2] Trip is selected in *parameter 2-13 Brake Power Monitoring*, the frequency converter trips when the dissipated braking power reaches 100%.

WARNING

If the brake transistor is short-circuited, there is a risk of substantial power being transmitted to the brake resistor.

WARNING/ALARM 27, Brake chopper fault

This alarm/warning could occur if the brake resistor overheats. Terminals 104 and 106 are available as brake resistors Klixon inputs.

NOTICE

This signal feedback is used by LHD to monitor the temperature of the HI inductor. This fault indicates that Klixon opened on the HI inductor at the active filter side.

WARNING/ALARM 28, Brake check failed

The brake resistor is not connected or not working. Check *parameter 2-15 Brake Check*.

ALARM 29, Heat Sink temp

The maximum temperature of the heat sink has been exceeded. The temperature fault resets when the temperature falls below a defined heat sink temperature. The trip and reset points vary based on the frequency converter power size.

Troubleshooting

Check for the following conditions.

- Ambient temperature too high.
- Motor cables too long.
- Incorrect airflow clearance above and below the frequency converter.
- Blocked airflow around the frequency converter.
- Damaged heat sink fan.
- Dirty heat sink.

For D, E, and F enclosures, this alarm is based on the temperature measured by the heat sink sensor mounted inside the IGBT modules. For the F enclosures, the thermal sensor in the rectifier module can also cause this alarm.

Troubleshooting

- Check the fan resistance.
- Check the soft charge fuses.
- Check the IGBT thermal sensor.

ALARM 30, Motor phase U missing

Motor phase U between the frequency converter and the motor is missing.

Troubleshooting

- Remove the power from the frequency converter and check motor phase U.

ALARM 31, Motor phase V missing

Motor phase V between the frequency converter and the motor is missing.

Troubleshooting

- Remove the power from the frequency converter and check motor phase V.

ALARM 32, Motor phase W missing

Motor phase W between the frequency converter and the motor is missing.

Troubleshooting

- Remove the power from the frequency converter and check motor phase W.

ALARM 33, Inrush fault

Too many power-ups have occurred within a short time period.

Troubleshooting

- Let the unit cool to operating temperature.

WARNING/ALARM 34, Fieldbus communication fault

The fieldbus on the communication option card is not working.

WARNING/ALARM 36, Mains failure

This warning/alarm is only active if the supply voltage to the frequency converter is lost and *parameter 14-10 Mains Failure* is not set to option [0] *No Function*. Check the fuses to the frequency converter and mains supply to the unit.

ALARM 38, Internal fault

When an internal fault occurs, a code number defined in *Table 7.1* is displayed.

Troubleshooting

- Cycle the power.
- Check that the option is properly installed.
- Check for loose or missing wiring.

It may be necessary to contact Danfoss Service or the supplier. Note the code number for further troubleshooting directions.

Number	Text
0	The serial port cannot be initialised. Contact your Danfoss supplier or Danfoss Service.
256-258	The power EEPROM data is defective or too old.
512	The control board EEPROM data is defective or too old.
513	Communication time-out reading EEPROM data
514	Communication time-out reading EEPROM data
515	Application-oriented control cannot recognise the EEPROM data.
516	Cannot write to the EEPROM because a write command is in progress.
517	The write command is under time-out.
518	Failure in the EEPROM.
519	Missing or invalid barcode data in EEPROM.
783	Parameter value outside of minimum/maximum limits.
1024-1279	A CAN telegram could not be sent.
1281	Digital signal processor flash time-out.

Number	Text
1282	Power micro software version mismatch.
1283	Power EEPROM data version mismatch.
1284	Cannot read digital signal processor software version.
1299	The option software in slot A is too old.
1300	The option software in slot B is too old.
1301	The option software in slot C0 is too old.
1302	The option software in slot C1 is too old.
1315	The option software in slot A is not supported (not allowed).
1316	The option software in slot B is not supported (not allowed).
1317	The option software in slot C0 is not supported (not allowed).
1318	The option software in slot C1 is not supported (not allowed).
1379	Option A did not respond when calculating the platform version
1380	Option B did not respond when calculating the platform version.
1381	Option C0 did not respond when calculating the platform version.
1382	Option C1 did not respond when calculating the platform version.
1536	An exception in the application-oriented control is registered. The debug information is written on the LCP.
1792	DSP Watch Dog is active. Debugging of power part data, motor-oriented control data not transferred correctly.
2049	Power data restarted.
2064-2072	H081x: Option in slot x has restarted.
2080-2088	H082x: Option in slot x has issued a power-up wait.
2096-2104	H983x: Option in slot x has issued a legal power-up wait.
2304	Could not read any data from the power EEPROM.
2305	Missing software version from the power unit.
2314	Missing power unit data from the power unit.
2315	Missing software version from the power unit.
2316	Missing lo_statepage from the power unit.
2324	The power card configuration is determined to be incorrect at power-up.
2325	A power card has stopped communicating while mains power is applied.
2326	The power card configuration is determined to be incorrect after the delay for power cards to register.
2327	Too many power card locations have been registered as present.
2330	The power size information between the power cards does not match.
2561	No communication from DSP to ATACD.

Number	Text
2562	No communication from ATACD to DSP (state running).
2816	Stack overflow control board module
2817	Scheduler slow tasks
2818	Fast tasks
2819	Parameter thread
2820	LCP stack overflow
2821	Serial port overflow
2822	USB port overflow
2836	cfListMempool is too small.
3072–5122	The parameter value is outside its limits.
5123	Option in slot A: Hardware incompatible with the control board hardware.
5124	Option in slot B: Hardware incompatible with the control board hardware.
5125	Option in slot C0: Hardware incompatible with the control board hardware.
5126	Option in slot C1: Hardware incompatible with the control board hardware.
5376–6231	Out of memory

Table 7.1 Internal Fault, Code Numbers

ALARM 39, Heat sink sensor

No feedback from the heat sink temperature sensor.

The signal from the IGBT thermal sensor is not available on the power card. The problem could be on the power card, on the gate drive card, or the ribbon cable between the power card and gate drive card.

WARNING 40, Overload of digital output terminal 27

Check the load connected to terminal 27 or remove the short circuit connection. Check *parameter 5-00 Digital I/O Mode* and *parameter 5-01 Terminal 27 Mode*.

WARNING 41, Overload of digital output terminal 29

Check the load connected to terminal 29 or remove the short circuit connection. Check *parameter 5-00 Digital I/O Mode* and *parameter 5-02 Terminal 29 Mode*.

WARNING 42, Overload of digital output on X30/6 or overload of digital output on X30/7

For X30/6, check the load connected to X30/6 or remove the short circuit connection. Check *parameter 5-32 Term X30/6 Digi Out (MCB 101)*.

For X30/7, check the load connected to X30/7 or remove the short-circuit connection. Check *parameter 5-33 Term X30/7 Digi Out (MCB 101)*.

ALARM 45, Earth fault 2

Ground fault.

Troubleshooting

- Check for proper grounding and loose connections.
- Check for proper wire size.
- Check the motor cables for short circuits or leakage currents.

ALARM 46, Power card supply

The supply on the power card is out of range.

There are 3 power supplies generated by the switch mode power supply (SMPS) on the power card: 24 V, 5 V, and ± 18 V. When powered with 24 V DC with the MCB 107 option, only the 24 V and 5 V supplies are monitored. When powered with 3-phase mains voltage, all 3 supplies are monitored.

WARNING 47, 24 V supply low

The supply on the power card is out of range.

There are 3 supplies generated by the switch mode supply (SMPS) on the power card:

- 24 V.
- 5 V.
- ± 18 V.

Troubleshooting

- Check for a defective power card.

WARNING 48, 1.8 V supply low

The 1.8 V DC supply used on the control card is outside of the allowable limits. The supply is measured on the control card. Check for a defective control card. If an option card is present, check for overvoltage.

WARNING 49, Speed limit

When the speed is outside of the specified range in *parameter 4-11 Motor Speed Low Limit [RPM]* and *parameter 4-13 Motor Speed High Limit [RPM]*, the frequency converter shows a warning. When the speed is below the specified limit in *parameter 1-86 Trip Speed Low [RPM]* (except when starting or stopping), the frequency converter trips.

ALARM 50, AMA calibration failed

Contact the Danfoss supplier or Danfoss Service.

ALARM 51, AMA check U_{nom} and I_{nom}

The settings for motor voltage, motor current, and motor power are wrong. Check the settings in *parameters 1–20 to 1–25*.

ALARM 52, AMA low I_{nom}

The motor current is too low. Check the settings in *parameter 4-18 Current Limit*.

ALARM 53, AMA motor too big

The motor is too big for the AMA to operate.

ALARM 54, AMA motor too small

The motor is too small for the AMA to operate.

ALARM 55, AMA parameter out of range

The parameter values of the motor are outside of the acceptable range. AMA cannot run.

ALARM 56, AMA interrupted by user

The user has interrupted AMA.

ALARM 57, AMA internal fault

Continue to restart the AMA, until the AMA is carried out.

NOTICE

Repeated runs may heat the motor to a level where the resistance R_s and R_r are increased. In most cases, however, this behaviour is not critical.

ALARM 58, AMA Internal fault

Contact the Danfoss supplier.

WARNING 59, Current limit

The current is higher than the value in *parameter 4-18 Current Limit*. Ensure that motor data in *parameters 1-20 to 1-25* are set correctly. Increase the current limit if necessary. Ensure that the system can operate safely at a higher limit.

WARNING 60, External interlock

External interlock has been activated. To resume normal operation, apply 24 V DC to the terminal programmed for external interlock and reset the frequency converter (via serial communication, digital I/O, or by pressing [Reset]).

WARNING/ALARM 61, Tracking error

An error has occurred between the calculated motor speed and the speed measurement from the feedback device. The function warning/alarm/disable is set in *parameter 4-30 Motor Feedback Loss Function*. Accepted error setting in *parameter 4-31 Motor Feedback Speed Error* and the allowed time the error occur setting in *parameter 4-32 Motor Feedback Loss Timeout*. During a commissioning procedure, the function could be effective.

WARNING 62, Output frequency at maximum limit

The output frequency is higher than the value set in *parameter 4-19 Max Output Frequency*.

ALARM 63, Mechanical brake low

The actual motor current has not exceeded the release brake current within the start delay time window.

ALARM 64, Voltage Limit

The load and speed combination demands a motor voltage higher than the actual DC-link voltage.

WARNING/ALARM 65, Control card over temperature

The cut-out temperature of the control card is 80 °C.

Troubleshooting

- Check that the ambient operating temperature is within the limits.
- Check for clogged filters.
- Check the fan operation.
- Check the control card.

WARNING 66, Heat sink temperature low

The frequency converter is too cold to operate. This warning is based on the temperature sensor in the IGBT module.

Increase the ambient temperature of the unit. Also, a trickle amount of current can be supplied to the frequency converter whenever the motor is stopped by setting *parameter 2-00 DC Hold/Preheat Current* at 5% and *parameter 1-80 Function at Stop*.

Troubleshooting

The heat sink temperature measured as 0 °C could indicate that the temperature sensor is defective, causing the fan speed to increase to the maximum. This warning results if the sensor wire between the IGBT and the gate drive card is disconnected. Also, check the IGBT thermal sensor.

ALARM 67, Option module configuration has changed

1 or more options have either been added or removed since the last power-down. Check that the configuration change is intentional and reset the unit.

ALARM 68, Safe Stop activated

STO has been activated. To resume normal operation, apply 24 V DC to terminal 37, then send a reset signal (via bus, digital I/O, or by pressing [Reset]).

ALARM 69, Power card temperature

The temperature sensor on the power card is either too hot or too cold.

Troubleshooting

- Check the operation of the door fans.
- Check that the filters for the door fans are not blocked.
- Check that the gland plate is properly installed on IP21/IP54 (NEMA 1/12) frequency converters.

ALARM 70, Illegal FC configuration

The control card and power card are incompatible. To check compatibility, contact the Danfoss supplier with the type code of the unit from the nameplate and the part numbers of the cards.

ALARM 71, PTC 1 Safe Torque Off

STO has been activated from the VLT® PTC Thermistor Card MCB 112 (motor too warm). Normal operation can resume when the VLT® PTC Thermistor Card MCB 112 applies 24 V DC to terminal 37 (when the motor temperature is acceptable) and when the digital input from the VLT® PTC Thermistor Card MCB 112 is deactivated. When that happens, a reset signal is be sent (via Bus, Digital I/O, or by pressing [Reset]).

NOTICE

If automatic restart is enabled, the motor could start when the fault is cleared.

ALARM 72, Dangerous failure

STO with trip lock. Unexpected signal levels on safe stop and digital input from the VLT® PTC Thermistor Card MCB 112.

WARNING 73, Safe Stop auto restart

Safe Torque Off activated. With automatic restart enabled, the motor can start when the fault is cleared.

WARNING 76, Power unit setup

The required number of power units does not match the detected number of active power units.

Troubleshooting

When replacing an F-frame module, this warning occurs, if the power-specific data in the module power card does not match the rest of the frequency converter. Confirm that the spare part and its power card are the correct part number.

WARNING 77, Reduced power mode

The frequency converter is operating in reduced power mode (less than the allowed number of inverter sections). This warning is generated on power cycle when the frequency converter is set to run with fewer inverters and remains on.

ALARM 79, Illegal power section configuration

The scaling card has an incorrect part number or is not installed. The MK102 connector on the power card could not be installed.

ALARM 80, Drive initialised to default value

Parameter settings are initialised to default settings after a manual reset. To clear the alarm, reset the unit.

ALARM 81, CSIV corrupt

CSIV file has syntax errors.

ALARM 82, CSIV parameter error

CSIV failed to initialise a parameter.

ALARM 85, Dang fail PB

PROFIBUS/PROFIsafe error.

WARNING/ALARM 104, Mixing fan fault

The fan is not operating. The fan monitor checks that the fan is spinning at power-up or whenever the mixing fan is turned on. The mixing-fan fault can be configured as a warning or an alarm trip in *parameter 14-53 Fan Monitor*.

Troubleshooting

- Cycle power to the frequency converter to determine if the warning/alarm returns.

ALARM 243, Brake IGBT

This alarm is only for enclosure size F frequency converters. It is equivalent to Alarm 27. The report value in the alarm log indicates which power module generated the alarm:

- 1 = Left most inverter module.
- 2 = Middle inverter module in enclosure sizes F12 or F13.
- 2 = Right inverter module in enclosure sizes F10 or F11.
- 2 = Second frequency converter from the left inverter module in enclosure size F14.
- 3 = Right inverter module in enclosure sizes F12 or F13.
- 3 = Third from the left inverter module in enclosure size F14 or F15.

4 = Far right inverter module in enclosure size F14.

5 = Rectifier module.

6 = Right rectifier module in enclosure size F14 or F15.

ALARM 244, Heat Sink temperature

This alarm is only for enclosure type F frequency converters. It is equivalent to Alarm 29. The report value in the alarm log indicates which power module generated the alarm:

1 = Left most inverter module.

2 = Middle inverter module in enclosure size F12 or F13.

2 = Right inverter module in enclosure size F10 or F11.

2 = Second frequency converter from the left inverter module in enclosure size F14 or F15.

3 = Right inverter module in enclosure sizes F12 or F13.

3 = Third from the left inverter module in enclosure size F14 or F15.

4 = Far right inverter module in enclosure sizes F14 or F15.

5 = Rectifier module.

6 = Right rectifier module in enclosure sizes F14 or F15.

ALARM 245, Heat Sink sensor

This alarm is only for enclosure size F frequency converters. It is equivalent to Alarm 39. The report value in the alarm log indicates which power module generated the alarm:

1 = Left most inverter module.

2 = Middle inverter module in enclosure sizes F12 or F13.

2 = Right inverter module in enclosure sizes F10 or F11.

2 = Second frequency converter from the left inverter module in enclosure size F14 or F15.

3 = Right inverter module in enclosure sizes F12 or F13.

3 = Third from the left inverter module in enclosure size F14 or F15.

4 = Far right inverter module in enclosure size F14 or F15.

5 = Rectifier module.

6 = Right rectifier module in enclosure size F14 or F15.

The 12-pulse frequency converter may generate this warning/alarm when one of the disconnects or circuit breakers is opened while the unit is on.

ALARM 246, Power card supply

This alarm is only for enclosure size F frequency converters. It is equivalent to Alarm 46. The report value in the alarm log indicates which power module generated the alarm:

- 1 = Left most inverter module.
- 2 = Middle inverter module in enclosure sizes F12 or F13.
- 2 = Right inverter module in enclosure sizes F10 or F11.
- 2 = Second frequency converter from the left inverter module in enclosure size F14 or F15.
- 3 = Right inverter module in enclosure sizes F12 or F13.
- 3 = Third from the left inverter module in enclosure size F14 or F15.
- 4 = Far right inverter module in enclosure size F14 or F15.
- 5 = Rectifier module.
- 6 = Right rectifier module in enclosure size F14 or F15.

ALARM 247, Power card temperature

This alarm is only for enclosure size F frequency converters. It is equivalent to Alarm 69. The report value in the alarm log indicates which power module generated the alarm:

- 1 = Left most inverter module.
- 2 = Middle inverter module in enclosure sizes F12 or F13.
- 2 = Right inverter module in enclosure sizes F10 or F11.
- 2 = Second frequency converter from the left inverter module in enclosure size F14 or F15.
- 3 = Right inverter module in enclosure sizes F12 or F13.
- 3 = Third from the left inverter module in enclosure size F14 or F15.
- 4 = Far right inverter module in enclosure size F14 or F15.
- 5 = Rectifier module.
- 6 = Right rectifier module in enclosure size F14 or F15.

ALARM 248, Illegal power section configuration

This alarm is only for enclosure size F frequency converters. It is equivalent to Alarm 79. The report value in the alarm log indicates which power module generated the alarm:

- 1 = Left most inverter module.
- 2 = Middle inverter module in enclosure sizes F12 or F13.
- 2 = Right inverter module in enclosure sizes F10 or F11.
- 2 = Second frequency converter from the left inverter module in enclosure size F14 or F15.
- 3 = Right inverter module in enclosure sizes F12 or F13.
- 3 = Third from the left inverter module in enclosure sizes F14 or F15.
- 4 = Far right inverter module in enclosure sizes F14 or F15.
- 5 = Rectifier module.
- 6 = Right rectifier module in enclosure size F14 or F15.

WARNING 250, New spare part

A component in the frequency converter has been replaced.

Troubleshooting

- Reset the frequency converter for normal operation.

WARNING 251, New typecode

The power card or other components have been replaced and the type code has been changed.

Troubleshooting

- Reset to remove the warning and resume normal operation.

7.4 Warnings and Alarm Definitions - Active Filter

NOTICE

After a manual reset pressing [Reset], press [Auto On] or [Hand On] to restart the unit.

Number	Description	Warning	Alarm/Trip	Alarm/Trip Lock	Parameter Reference
1	10 Volts low	X			
2	Live zero error	(X)	(X)		6-01
4	Mains phase loss	X			
5	DC link voltage high	X			
6	DC link voltage low	X			
7	DC over voltage	X	X		
8	DC under voltage	X	X		
13	Over current	X	X	X	
14	Earth fault	X	X	X	
15	Hardware mismatch		X	X	
16	Short circuit		X	X	
17	Control word timeout	(X)	(X)		8-04
23	Internal fan fault	X			
24	External fan fault	X			14-53
29	Heatsink temp	X	X	X	
33	Inrush fault		X	X	
34	Fieldbus fault	X	X		
35	Option fault	X	X		
38	Internal fault				
39	Heatsink sensor		X	X	
40	Overload of digital output terminal 27	(X)			5-00, 5-01
41	Overload of digital output terminal 29	(X)			5-00, 5-02
46	Pwr. card supply		X	X	
47	24 V supply low	X	X	X	
48	1.8 V supply low		X	X	
65	Control board over-temperature	X	X	X	
66	Heat sink temperature low	X			
67	Option configuration has changed		X		
68	Safe torque off activated		X		
69	Pwr. card temp		X	X	
70	Illegal FC configuration			X	
72	Dangerous failure			X	
73	Safe torque off auto restart				
76	Power unit setup	X			
79	Illegal PS config		X	X	
80	Unit initialised to default value		X		
250	New spare part			X	
251	New type code		X	X	
300	Mains cont. fault	X			
301	SC cont. fault	X			
302	Cap. over current	X	X		
303	Cap. earth fault	X	X		
304	DC over current	X	X		
305	Mains freq. limit		X		
306	Compensation Limit				
308	Resistor temp	X		X	
309	Mains earth fault	X	X		

Number	Description	Warning	Alarm/Trip	Alarm/Trip Lock	Parameter Reference
311	Switch. freq. limit		X		
312	CT range		X		
314	Auto CT interrupt		X		
315	Auto CT error		X		
316	CT location error	X			
317	CT polarity error	X			
318	CT ratio error	X			

Table 7.2 Alarm/Warning Code List

A trip is the action when an alarm has appeared. The trip disables the active filter and can be reset by pressing [Reset] or resetting via a digital input (parameter group 5-1* *Digital Inputs [1] Reset*). The original event that caused an alarm cannot damage the active filter or cause dangerous conditions. A trip lock is an action when an alarm occurs, which may cause damage to active filter or connected parts. A trip lock situation can only be reset by a power cycling.

Warning	Yellow
Alarm	Flashing red
Trip locked	Yellow and red

Table 7.3 LED Indicator Lights

Alarm word and extended status word					
Bit	Hex	Dec	Alarm word	Warning word	Extended status word
0	00000001	1	Mains cont. fault	Reserved	Reserved
1	00000002	2	Heat sink temp	Heat sink temp	Auto CT running
2	00000004	4	Ground fault	Ground fault	Reserved
3	00000008	8	Ctrl.card temp	Ctrl.card temp	Reserved
4	00000010	16	Ctrl. word TO	Ctrl. word TO	Reserved
5	00000020	32	Over current	Over current	Reserved
6	00000040	64	SC cont. fault	Reserved	Reserved
7	00000080	128	Cap. over current	Cap. over current	Reserved
8	00000100	256	Cap. earth fault	Cap. earth fault	Reserved
9	00000200	512	Inverter overld.	Inverter overld.	Reserved
10	00000400	1024	DC under volt	DC under volt	Reserved
11	00000800	2048	DC over volt	DC over volt	Reserved
12	00001000	4096	Short circuit	DC voltage low	Reserved
13	00002000	8192	Inrush fault	DC voltage high	Reserved
14	00004000	16384	Mains ph. loss	Mains ph. loss	Reserved
15	00008000	32768	Auto CT error	Reserved	Reserved
16	00010000	65536	Reserved	Reserved	Reserved
17	00020000	131072	Internal fault	10 V low	Password Time Lock
18	00040000	262144	DC over current	DC over current	Password Protection
19	00080000	524288	Resistor temp	Resistor temp	Reserved
20	00100000	1048576	Mains earth fault	Mains earth fault	Reserved
21	00200000	2097152	Switch. freq. limit	Reserved	Reserved
22	00400000	4194304	Fieldbus fault	Fieldbus fault	Reserved
23	00800000	8388608	24 V supply low	24 V supply low	Reserved
24	01000000	16777216	CT range	Reserved	Reserved
25	02000000	33554432	1.8 V supply low	Reserved	Reserved
26	04000000	67108864	Reserved	Low temp	Reserved
27	08000000	134217728	Auto CT interrupt	Reserved	Reserved
28	10000000	268435456	Option change	Reserved	Reserved
29	20000000	536870912	Unit initialised	Unit initialised	Reserved
30	40000000	1073741824	Safe torque off	Safe torque off	Reserved
31	80000000	2147483648	Mains freq. limit	Extended status word	Reserved

Table 7.4 Description of Alarm Word, Warning Word, and Extended Status Word

The alarm words, warning words, and extended status words can be read out via serial bus or optional fieldbus for diagnosis. See also *parameter 16-90 Alarm Word*, *parameter 16-92 Warning Word*, and *parameter 16-94 Ext. Status Word*. Reserved means that the bit is not guaranteed to be any particular value. Reserved bits should not be used for any purpose.

7.4.1 Fault Messages for Active Filter

WARNING 1, 10 volts low

The control card voltage is below 10 V from terminal 50. Remove some of the load from terminal 50, as the 10 V supply is overloaded. Maximum 15 mA or minimum 590 Ω.

WARNING/ALARM 2, Live zero error

The signal on terminal 53 or 54 is less than 50% of the value set in:

- *Parameter 6-10 Terminal 53 Low Voltage.*
- *Parameter 6-12 Terminal 53 Low Current.*
- *Parameter 6-20 Terminal 54 Low Voltage.*
- *Parameter 6-22 Terminal 54 Low Current.*

WARNING 4, Mains phase loss

A phase is missing on the supply side, or the mains voltage imbalance is too high.

WARNING 5, DC-link voltage high

The DC-link voltage (DC) is higher than the high-voltage warning limit. The unit is still active.

WARNING 6, DC-link voltage low

The DC-link voltage (DC) is below the low-voltage warning limit. The unit is still active.

WARNING/ALARM 7, DC overvoltage

If the DC-link voltage exceeds the limit, the unit trips.

WARNING/ALARM 8, DC under voltage

If the DC-link voltage (DC) drops below the undervoltage limit, the filter checks if a 24 V back-up supply is connected. If not, the filter trips. Check that the mains voltage matches the nameplate specification.

WARNING/ALARM 13, Overcurrent

The unit current limit has been exceeded.

ALARM 14, Ground fault

The sum current of the IGBT CTs does not equal 0. Check if the resistance of any phase-to-ground has a low value. Check both before and after mains contactor. Ensure that IGBT current transducers, connection cables, and connectors are OK.

ALARM 15, Incomp. Hardware

A mounted option is incompatible with the present control card SW/HW.

ALARM 16, Short circuit

There is a short circuit in the output. Turn off the unit and correct the error.

WARNING/ALARM 17, Control word time-out

There is no communication to the unit.

The warning is only active when *parameter 8-04 Control Word Timeout Function* is not set to off.

Possible correction: Increase *parameter 8-03 Control Word Timeout Time*. Change *parameter 8-04 Control Word Timeout Function*

WARNING 23, Internal fan fault

Internal fans have failed due to defect hardware or fans not mounted.

WARNING 24, External fan fault

External fans have failed due to defective hardware or fans not mounted.

ALARM 29, Heat sink temp

The maximum temperature of the heat sink has been exceeded. The temperature fault is not reset until the temperature drops below a defined heat sink temperature.

ALARM 33, Inrush fault

Check whether a 24 V external DC supply has been connected.

WARNING/ALARM 34, Fieldbus communication fault

The fieldbus on the communication option card is not working.

WARNING/ALARM 35, Option fault:

Contact Danfoss or supplier.

ALARM 38, Internal fault

Contact Danfoss or supplier.

ALARM 39, Heat sink sensor

No feedback from the heat sink temperature sensor.

WARNING 40, Overload of digital output terminal 27

Check the load connected to terminal 27 or remove short circuit connection.

WARNING 41, Overload of digital output terminal 29

Check the load connected to terminal 29 or remove short circuit connection.

ALARM 46, Power card supply

The supply on the power card is out of range.

WARNING 47, 24 V supply low

Contact Danfoss or supplier.

WARNING 48, 1.8 V supply low

Contact Danfoss or supplier.

WARNING/ALARM/TRIP 65, Control card overtemperature

Control card overtemperature: The cut-out temperature of the control card is 80 °C.

WARNING 66, Heat sink temperature low

This warning is based on the temperature sensor in the IGBT module.

Troubleshooting

The heat sink temperature measured as 0 °C could indicate that the temperature sensor is defective, causing the fan speed to increase to the maximum. If the sensor wire between the IGBT and the gate drive card is disconnected, this warning would result. Also, check the IGBT thermal sensor.

ALARM 67, Option module configuration has changed

One or more options have either been added or removed since the last power-down.

ALARM 68, Safe Torque Off (STO) activated

Safe Torque Off (STO) has been activated. To resume normal operation, apply 24 V DC to terminal 37, then send a reset signal (via bus, digital I/O, or by pressing [Reset]). See *parameter 5-19 Terminal 37 Safe Stop*.

ALARM 69, Power card temperature

The temperature sensor on the power card is either too hot or too cold.

ALARM 70, Illegal FC Configuration

Actual combination of control board and power board is illegal.

ALARM 79, Illegal power section configuration

The scaling card is the incorrect part number or not installed. Also MK102 connector on the power card could not be installed.

ALARM 80, Unit initialised to default value

Parameter settings are initialised to default settings after a manual reset.

ALARM 247, Power card temperature

Power card overtemperature. A report value indicates the source of the alarm (from left):

1–4 inverter.

5–8 rectifier.

ALARM 250, New spare part

The power or switch mode supply has been exchanged. Restore the filter type code in the EEPROM. Select the correct type code in *parameter 14-23 Typecode Setting* according to the label on the unit. Remember to select *Save to EEPROM* to complete.

ALARM 251, New type code

The filter has a new type code.

ALARM 300, Mains cont. fault

The feedback from the mains contactor did not match the expected value within the allowed time frame. Contact Danfoss or supplier.

ALARM 301, SC cont. fault

The feedback from the soft charge contactor did not match the expected value within the allowed time frame. Contact Danfoss or supplier.

ALARM 302, Cap. overcurrent

Excessive current was detected through the AC capacitors. Contact Danfoss or supplier.

ALARM 303, Cap. ground fault

A ground fault was detected through the AC capacitor currents. Contact Danfoss or supplier.

ALARM 304, DC overcurrent

Excessive current through the DC-link capacitor bank was detected. Contact Danfoss or supplier.

ALARM 305, Mains freq. limit

The mains frequency was outside the limits. Verify that the mains frequency is within product specification.

ALARM 306, Compensation limit

The needed compensation current exceeds unit capability. The unit runs at full compensation.

ALARM 308, Resistor temp

Excessive resistor heat sink temperature detected.

ALARM 309, Mains ground fault

A ground fault was detected in the mains currents. Check the mains for shorts and leakage current.

ALARM 310, RTDC buffer full

Contact Danfoss or supplier.

ALARM 311, Switch. freq. limit

The average switching frequency of the unit exceeded the limit. Verify that *parameter 300-10 Active Filter Nominal Voltage* and *parameter 300-22 CT Nominal Voltage* are set correctly. If so, contact Danfoss or supplier.

ALARM 312, CT range

Current transformer measurement limitation was detected. Verify that the CTs used are an appropriate ratio.

ALARM 314, Auto CT interrupt

Auto CT detection has been interrupted.

ALARM 315, Auto CT error

An error was detected while performing auto CT detection. Contact Danfoss or supplier.

WARNING 316, CT location error

The auto CT function could not determine the correct locations of the CTs.

WARNING 317, CT polarity error

The auto CT function could not determine the correct polarity of the CTs.

WARNING 318, CT ratio error

The auto CT function could not determine the correct primary rating of the CTs.

7.5 Troubleshooting

Symptom	Possible cause	Test	Solution
Display dark/no function	Missing input power.	See <i>Table 5.1</i> .	Check the input power source.
	Missing or open fuses, or circuit breaker tripped.	See <i>Open fuses and Tripped circuit breaker</i> in this table for possible causes.	Follow the recommendations provided.
	No power to the LCP.	Check the LCP cable for proper connection or damage.	Replace the faulty LCP or connection cable.
	Shortcut on control voltage (terminal 12 or 50) or at control terminals.	Check the 24 V control voltage supply for terminals 12/13 to 20-39 or 10 V supply for terminals 50-55.	Wire the terminals properly.
	Wrong LCP (LCP from VLT® 2800 or 5000/6000/8000/ FCD or FCM).		Use only LCP 101 (P/N 130B1124) or LCP 102 (P/N 130B1107).
	Wrong contrast setting.		Press [Status] + [▲]/[▼] to adjust the contrast
	Display (LCP) is defective.	Test using a different LCP.	Replace the faulty LCP or connection cable.
	Internal voltage supply fault or SMPS is defective.		Contact supplier.
Intermittent display	Overloaded power supply (SMPS) due to improper control wiring or a fault within the frequency converter.	To rule out a problem in the control wiring, disconnect all control wiring by removing the terminal blocks.	If the display stays lit, then the problem is in the control wiring. Check the wiring for shorts or incorrect connections. If the display continues to cut out, follow the procedure for display dark.
Motor not running	Service switch open or missing motor connection.	Check if the motor is connected and the connection is not interrupted (by a service switch or other device).	Connect the motor and check the service switch.
	No mains power with 24 V DC option card.	If the display is functioning but no output, check that mains power is applied to the frequency converter.	Apply mains power to run the unit.
	LCP Stop.	Check if [Off] has been pressed.	Press [Auto On] or [Hand On] (depending on operation mode) to run the motor.
	Missing start signal (Standby).	Check <i>parameter 5-10 Terminal 18 Digital Input</i> for correct setting for terminal 18 (use default setting).	Apply a valid start signal to start the motor.
	Motor coast signal active (Coasting).	Check <i>5-12 Coast inv.</i> for correct setting for terminal 27 (use default setting).	Apply 24 V on terminal 27 or program this terminal to <i>no operation</i> .
	Wrong reference signal source.	Check reference signal: Local, remote or bus reference? Preset reference active? Terminal connection correct? Scaling of terminals correct? Reference signal available?	Program correct settings. Check <i>parameter 3-13 Reference Site</i> . Set preset reference active in parameter group <i>3-1* References</i> . Check for correct wiring. Check scaling of terminals. Check reference signal.
Motor running in wrong direction	Motor rotation limit.	Check that <i>parameter 4-10 Motor Speed Direction</i> is programmed correctly.	Program correct settings.
	Active reversing signal.	Check if a reversing command is programmed for the terminal in parameter group <i>5-1* Digital inputs</i> .	Deactivate reversing signal.
	Wrong motor phase connection.		See <i>chapter 4.6.1 Motor Cable</i> .

Symptom	Possible cause	Test	Solution
Motor is not reaching maximum speed	Frequency limits set wrong.	Check output limits in: <ul style="list-style-type: none"> • <i>Parameter 4-13 Motor Speed High Limit [RPM].</i> • <i>Parameter 4-14 Motor Speed High Limit [Hz].</i> • <i>Parameter 4-19 Max Output Frequency.</i> 	Program correct limits.
	Reference input signal not scaled correctly.	Check reference input signal scaling in <i>6-0* Analog I/O Mode</i> and parameter group <i>3-1* References</i> . Reference limits in parameter group <i>3-0* Reference Limit</i> .	Program correct settings.
Motor speed unstable	Possible incorrect parameter settings.	Check the settings of all motor parameters, including all motor compensation settings. For closed-loop operation, check PID settings.	Check settings in parameter group <i>1-6* Load Depen. Setting</i> . For closed-loop operation, check settings in parameter group <i>20-0* Feedback</i> .
Motor runs rough	Possible overmagnetisation.	Check for incorrect motor settings in all motor parameters.	Check motor settings in parameter groups <i>1-2* Motor Data</i> , <i>1-3* Adv Motor Data</i> , and <i>1-5* Load Indep. Setting</i> .
Motor does not brake	Possible incorrect settings in the brake parameters. Possible too short ramp down times.	Check brake parameters. Check ramp time settings.	Check parameter group <i>2-0* DC Brake</i> and <i>3-0* Reference Limits</i> .
Open power fuses or circuit breaker trip	Phase-to-phase shortcircuit.	Motor or panel has a short phase-to-phase. Check motor and panel phase for shortcircuits.	Eliminate any shortcircuits detected.
	Motor overload.	Motor is overloaded for the application.	Perform start-up test and verify that the motor current is within specifications. If motor current is exceeding nameplate full load current, motor may run only with reduced load. Review the specifications for the application.
	Loose connections.	Perform pre-startup check for loose connections.	Tighten loose connections.
Mains current imbalance greater than 3%	Problem with mains power (See <i>Alarm 4 Mains phase loss</i> description).	Rotate input power leads into the frequency converter 1 position: A to B, B to C, C to A.	If imbalanced leg follows the wire, it is a power problem. Check mains power supply.
	Problem with the frequency converter.	Rotate input power leads into the frequency converter 1 position: A to B, B to C, C to A.	If imbalance leg stays on same input terminal, it is a problem with the unit. Contact the supplier.
Motor current imbalance greater than 3%	Problem with motor or motor wiring.	Rotate output motor leads 1 position: U to V, V to W, W to U.	If imbalanced leg follows the wire, the problem is in the motor or motor wiring. Check motor and motor wiring.
	Problem with the frequency converters.	Rotate output motor leads 1 position: U to V, V to W, W to U.	If imbalance leg stays on same output terminal, it is a problem with the unit. Contact the supplier.

Symptom	Possible cause	Test	Solution
Acoustic noise or vibration (for example a fan blade is making noise or vibrations at certain frequencies)	Resonances, for example in the motor/fan system.	Bypass critical frequencies by using parameters in parameter group 4-6* <i>Speed Bypass</i> .	Check if noise and/or vibration have been reduced to an acceptable limit.
		Turn off overmodulation in <i>parameter 14-03 Overmodulation</i> .	
		Change switching pattern and frequency in parameter group 14-0* <i>Inverter Switching</i> .	
		Increase resonance dampening in <i>parameter 1-64 Resonance Dampening</i> .	

Table 7.5 Troubleshooting

8 Specifications

8.1 Power-Dependent Specifications

8.1.1 Mains Supply 3x380–480 V AC

Mains supply 3x380–480 V AC		N132		N160		N200		
High/normal load*		HO	NO	HO	NO	HO	NO	
	Typical shaft output at 400 V [kW]	132	160	160	200	200	250	
	Typical shaft output at 460 V [HP]	200	250	250	300	300	350	
	Typical shaft output at 480 V [kW]	160	200	200	250	250	315	
	Enclosure protection rating IP21	D1n		D2n		D2n		
	Enclosure protection rating IP54	D1n		D2n		D2n		
	Output current							
	Continuous (at 400 V) [A]	260	315	315	395	395	480	
	Intermittent (60 s overload) (at 400 V) [A]	390	347	473	435	593	528	
	Continuous (at 460/480 V) [A]	240	302	302	361	361	443	
	Intermittent (60 s overload) (at 460/480 V) [A]	360	332	453	397	542	487	
Continuous KVA (at 400 V) [KVA]	180	218	218	274	274	333		
Continuous KVA (at 460 V) [KVA]	191	241	241	288	288	353		
Continuous KVA (at 480 V) [KVA]	208	262	262	313	313	384		
Maximum input current								
	Continuous (at 400 V) [A]	251	304	304	381	381	463	
	Continuous (at 460/480 V) [A]	231	291	291	348	348	427	
	Maximum cable size, mains motor, brake, and load share [mm ² (AWG ²)]	Motor, brake and load share: 2x95 (2x3/0) Mains: 2x185 (2x350)		2x185 (2x350 mcm)		2x185 (2x350 mcm)		
	Maximum external mains fuses [A] ¹⁾	400		550		630		
	Total LHD loss 400 V AC [kW]	7428	8725	8048	9831	9753	11371	
	Total back channel loss 400 V AC [kW]	6302	7554	6877	8580	8503	10020	
	Total filter loss 400 V AC [kW]	4505	4954	4954	5714	5714	6234	
	Total LHD loss 460 V AC [kW]	7490	8906	7875	9046	8937	10626	
	Total back channel loss 460 V AC [kW]	5974	7343	6274	7374	7338	8948	
	Total filter loss 460 V AC [kW]	3604	4063	3751	4187	4146	4822	
Weight, enclosure protection rating IP21, IP54 [kg]	352		413		413			
Efficiency ⁴⁾	0.96							
Acoustic noise	85 dBa							
Output frequency	0–590 Hz							
Heat sink overtemperature trip	105 °C		105 °C		105 °C			
Power card ambient trip	85 °C							

* High overload = 150% current for 60 s, normal overload = 110% current for 60 s.

Table 8.1 D-frame Ratings

Mains supply 3x380–480 VAC										
		P250		P315		P355		P400		
High/ normal load*		HO	NO	HO	NO	HO	NO	HO	NO	
	Typical shaft output at 400 V [kW]	250	315	315	355	355	400	400	450	
	Typical shaft output at 460 V [HP]	350	450	450	500	500	600	550	600	
	Typical shaft output at 480 V [kW]	315	355	355	400	400	500	500	530	
	Enclosure protection rating IP21	E9		E9		E9		E9		
	Enclosure protection rating IP54	E9		E9		E9		E9		
	Output current									
	Continuous (at 400 V) [A]	480	600	600	658	658	745	695	800	
	Intermittent (60 s overload) (at 400 V) [A]	720	660	900	724	987	820	1043	880	
	Continuous (at 460/480 V) [A]	443	540	540	590	590	678	678	730	
	Intermittent (60 s overload) (at 460/480 V) [A]	665	594	810	649	885	746	1017	803	
Continuous KVA (at 400 V) [KVA]	333	416	416	456	456	516	482	554		
Continuous KVA (at 460 V) [KVA]	353	430	430	470	470	540	540	582		
Continuous KVA (at 480 V) [KVA]	384	468	468	511	511	587	587	632		
Maximum input current										
	Continuous (at 400 V) [A]	472	590	590	647	647	733	684	787	
	Continuous (at 460/480 V) [A]	436	531	531	580	580	667	667	718	
	Maximum cable size, mains, motor, and load share [mm ² (AWG ²)]	4x240 (4x500 mcm)		4x240 (4x500 mcm)		4x240 (4x500 mcm)		4x240 (4x500 mcm)		
	Maximum cable size, brake [mm ² (AWG ²)]	2x185 (2x350 mcm)		2x185 (2x350 mcm)		2x185 (2x350 mcm)		2x185 (2x350 mcm)		
	Maximum external mains fuses [A] ¹⁾	700		900		900		900		
	Total LHD loss 400 V AC [kW]	11587	14051	14140	15320	15286	17180	16036	18447	
	Total back channel loss 400 V AC [kW]	9011	11301	10563	11648	11650	13396	12348	14570	
	Total filter loss 400 V AC [kW]	6528	7346	7346	7788	7788	8503	8060	8974	
	Total LHD loss 460 V AC [kW]	10962	12936	13124	14083	13998	15852	15847	16962	
	Total back channel loss 460 V AC [kW]	8432	10277	9636	10522	10466	12184	12186	13214	
Total filter loss 460 V AC [kW]	6316	7066	7006	7359	7326	8033	8033	8435		
Weight, enclosure protection rating IP21, IP54 [kg]	596		623		646		646			
Efficiency ⁴⁾	0.96									
Acoustic noise	72 dBa									
Output frequency	0–600 Hz									
Heat sink overtemperature trip	105 °C									
Power card ambient trip	85 °C									

* High overload = 160% current for 60 s, normal overload = 110% current for 60 s.

Table 8.2 E-frame Ratings

Mains supply 3x380–480 V AC										
High/ normal load*		P450		P500		P560		P630		
		HO	NO	HO	NO	HO	NO	HO	NO	
	Typical shaft output at 400 V [kW]	450	500	500	560	560	630	630	710	
	Typical shaft output at 460 V [HP]	600	650	650	750	750	900	900	1000	
	Typical shaft output at 480 V [kW]	530	560	560	630	630	710	710	800	
	Enclosure protection rating IP21, 54	F18		F18		F18		F18		
	Output current									
	Continuous (at 400 V) [A]	800	880	880	990	990	1120	1120	1260	
	Intermittent (60 s overload) (at 400 V) [A]	1200	968	1320	1089	1485	1232	1680	1386	
	Continuous (at 460/480 V) [A]	730	780	780	890	890	1050	1050	1160	
	Intermittent (60 s overload) (at 460/480 V) [A]	1095	858	1170	979	1335	1155	1575	1276	
	Continuous KVA (at 400 V) [KVA]	554	610	610	686	686	776	776	873	
	Continuous KVA (at 460 V) [KVA]	582	621	621	709	709	837	837	924	
	Continuous KVA (at 480 V) [KVA]	632	675	675	771	771	909	909	1005	
Maximum input current										
	Continuous (at 400 V) [A]	779	857	857	964	964	1090	1090	1227	
	Continuous (at 460/ 480 V) [A]	711	759	759	867	867	1022	1022	1129	
	Maximum cable size, motor [mm ² (AWG ²)]	8x150 (8x300 mcm)								
	Maximum cable size, mains F1/F2 [mm ² (AWG ²)]	8x240 (8x500 mcm)								
	Maximum cable size, mains F3/F4 [mm ² (AWG ²)]	8x456 (8x900 mcm)								
	Maximum cable size, loadsharing [mm ² (AWG ²)]	4x120 (4x250 mcm)								
Maximum cable size, brake [mm ² (AWG ²)]	4x185 (4x350 mcm)									
Maximum external mains fuses [A] ¹⁾	1600					2000				
Total LHD loss 400 V AC [kW]	20077	21909	21851	24592	23320	26640	26559	30519		
Total back channel loss 400 V AC [kW]	16242	17767	17714	19984	18965	21728	21654	24936		
Total filter loss 400 V AC [kW]	11047	11747	11705	12771	12670	14128	14068	15845		
Total LHD loss 460 V AC [kW]	18855	19896	19842	22353	21260	25030	25015	27989		
Total back channel loss 460 V AC [kW]	15260	16131	16083	18175	17286	20428	20417	22897		
Total filter loss 460 V AC [kW]	10643	11020	10983	11929	11846	13435	13434	14776		
Maximum panel options losses	400									
Weight, enclosure protection ratings IP21, IP54 [kg]	2009									
Weight frequency converter section [kg]	1004									
Weight filter section [kg]	1005									
Efficiency ⁴⁾	0.96									
Acoustic noise	69 dBA									
Output frequency	0–600 Hz									
Heat sink overtemperature trip	105 °C									
Power card ambient trip	85 °C									

* High overload = 160% current for 60 s, normal overload = 110% current for 60 s.

Table 8.3 F-frame Ratings

- 1) For type of fuse see *chapter 8.4.1 Fuses*.
- 2) American Wire Gauge.
- 3) Measured using 5 m screened motor cables at rated load and rated frequency.
- 4) The typical power loss is at nominal load conditions and expected to be within $\pm 15\%$ (tolerance relates to variety in voltage and cable conditions). Values are based on a typical motor efficiency (eff2/eff3 border line). Motors with lower efficiency also add to the power loss in the frequency converter and opposite. If the switching frequency is increased compared to the default setting, the power losses may rise significantly. LCP and typical control card power consumptions are included. Further options and customer load may add up to 30 W to the losses (though typical only 4 W extra for a fully loaded control card, or options for slot A or slot B, each). Although measurements are made with state-of-the-art equipment, some measurement inaccuracy must be allowed for ($\pm 5\%$).

8.1.2 Derating for Temperature

The frequency converter automatically derates the switching frequency, switching type, or output current under certain load or ambient conditions as described in the following. *Illustration 8.1 to Illustration 8.8* show the derating curve for SFAWM and 60 AVM switching modes.

8

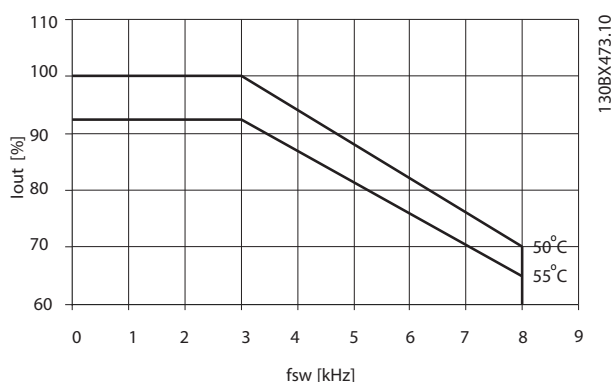

Illustration 8.1 Derating Enclosure Size D, N132 to N200 380-480 V (T5) High overload 150%, 60 AVM

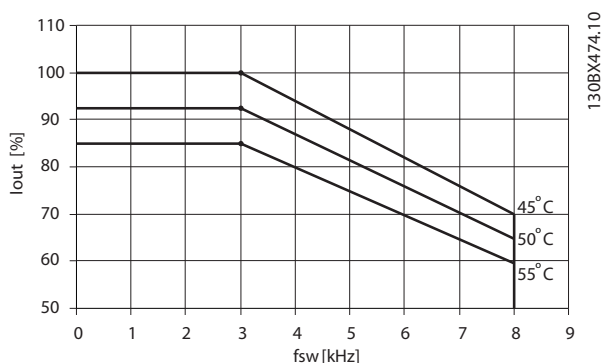

Illustration 8.2 Derating Enclosure Size D, N132 to N200 380-480 V (T5) Normal Overload 110%, 60 AVM

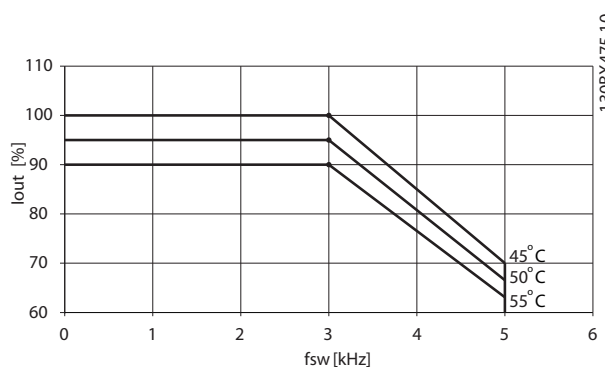

Illustration 8.3 Derating Enclosure Size D, N132 to N200 380-480 V (T5) High overload 150%, SFAWM

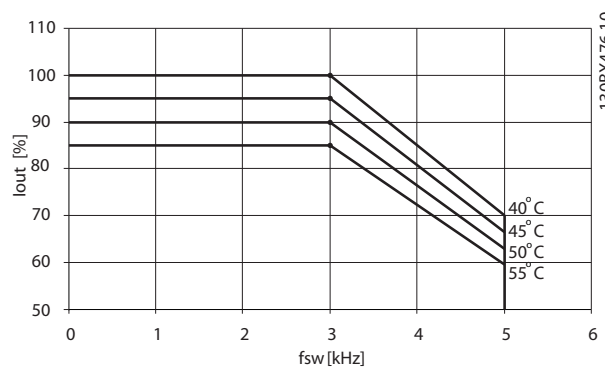

Illustration 8.4 Derating Enclosure Size D, N132 to N200 380-480 V (T5) Normal Overload 110%, SFAWM

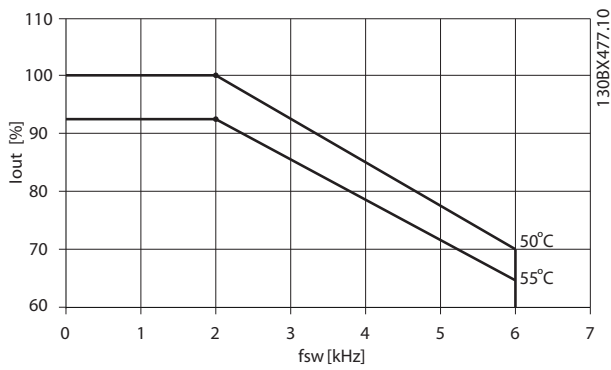

Illustration 8.5 Derating Enclosure Sizes E and F, P250 to P630 380-480 V (T5) High overload 150%, 60 AVM

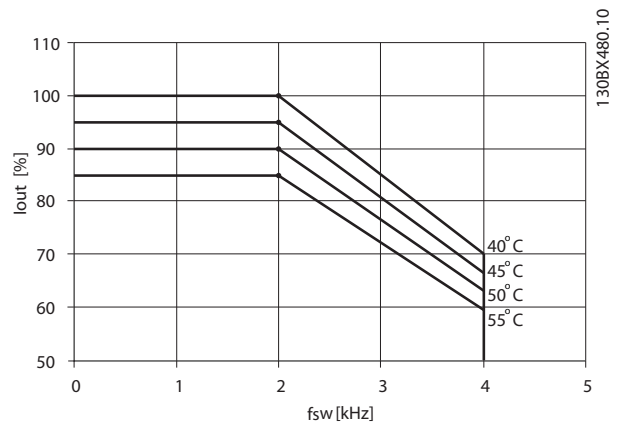

Illustration 8.8 Derating Enclosure Sizes E and F, P250 to P630 380-480 V (T5) Normal Overload 110%, SFAVM

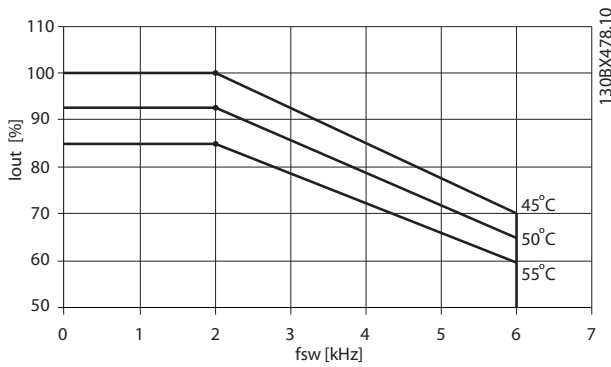

Illustration 8.6 Derating Enclosure Sizes E and F, P250 to P630 380-480 V (T5) Normal Overload 110%, 60 AVM

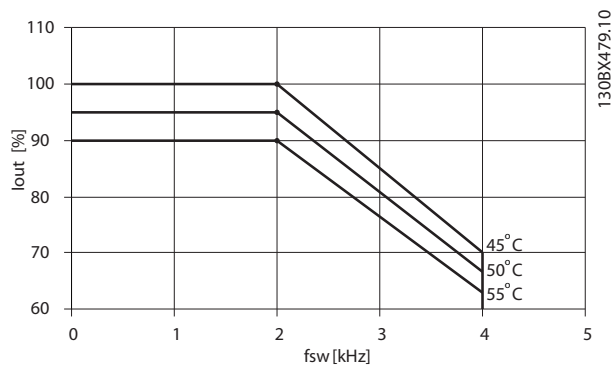
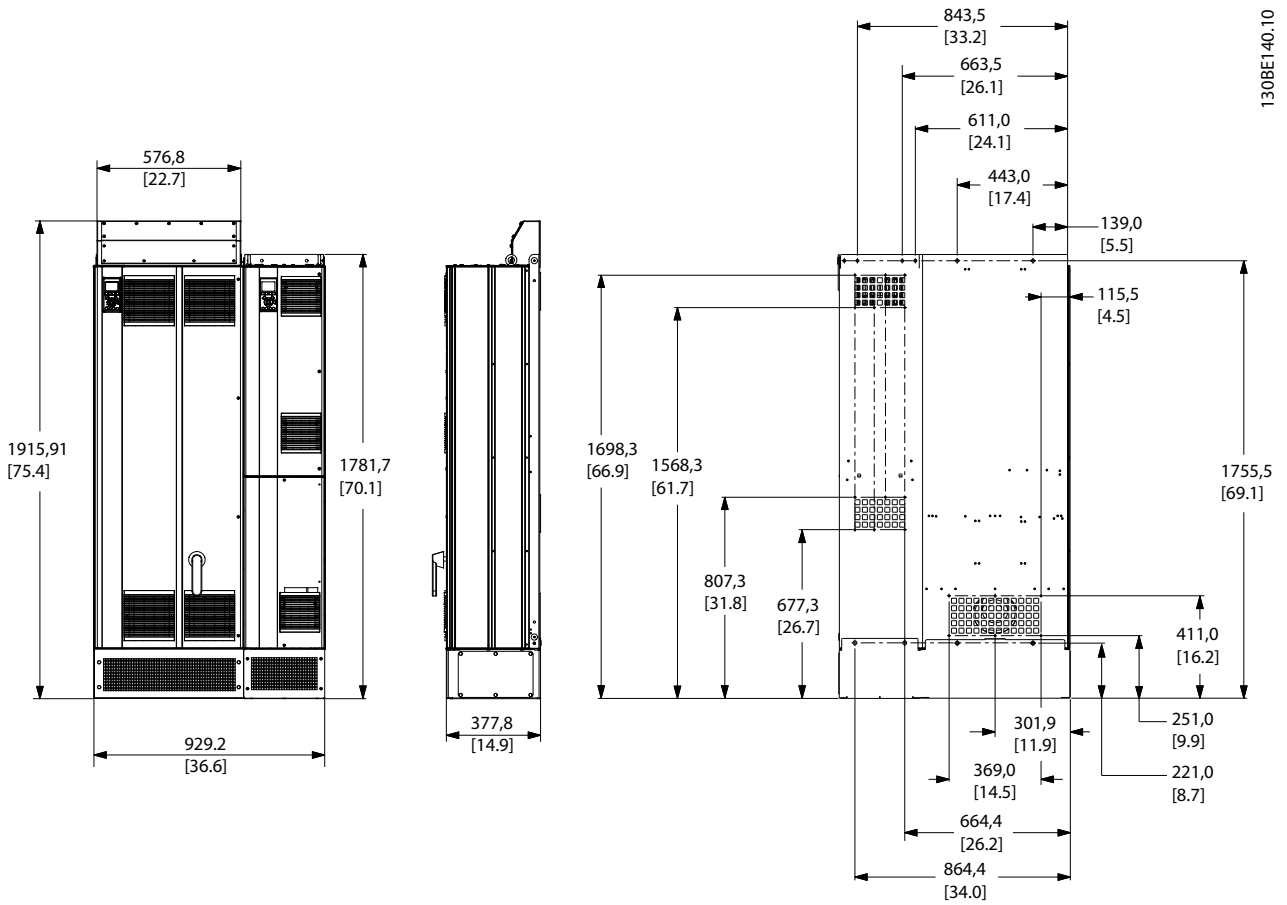

Illustration 8.7 Derating Enclosure Sizes E and F, P250 to P630 380-480 V (T5) High overload 150%, SFAVM

8.2 Mechanical Dimensions



130BET40.10

Illustration 8.9 Enclosure Size D1n

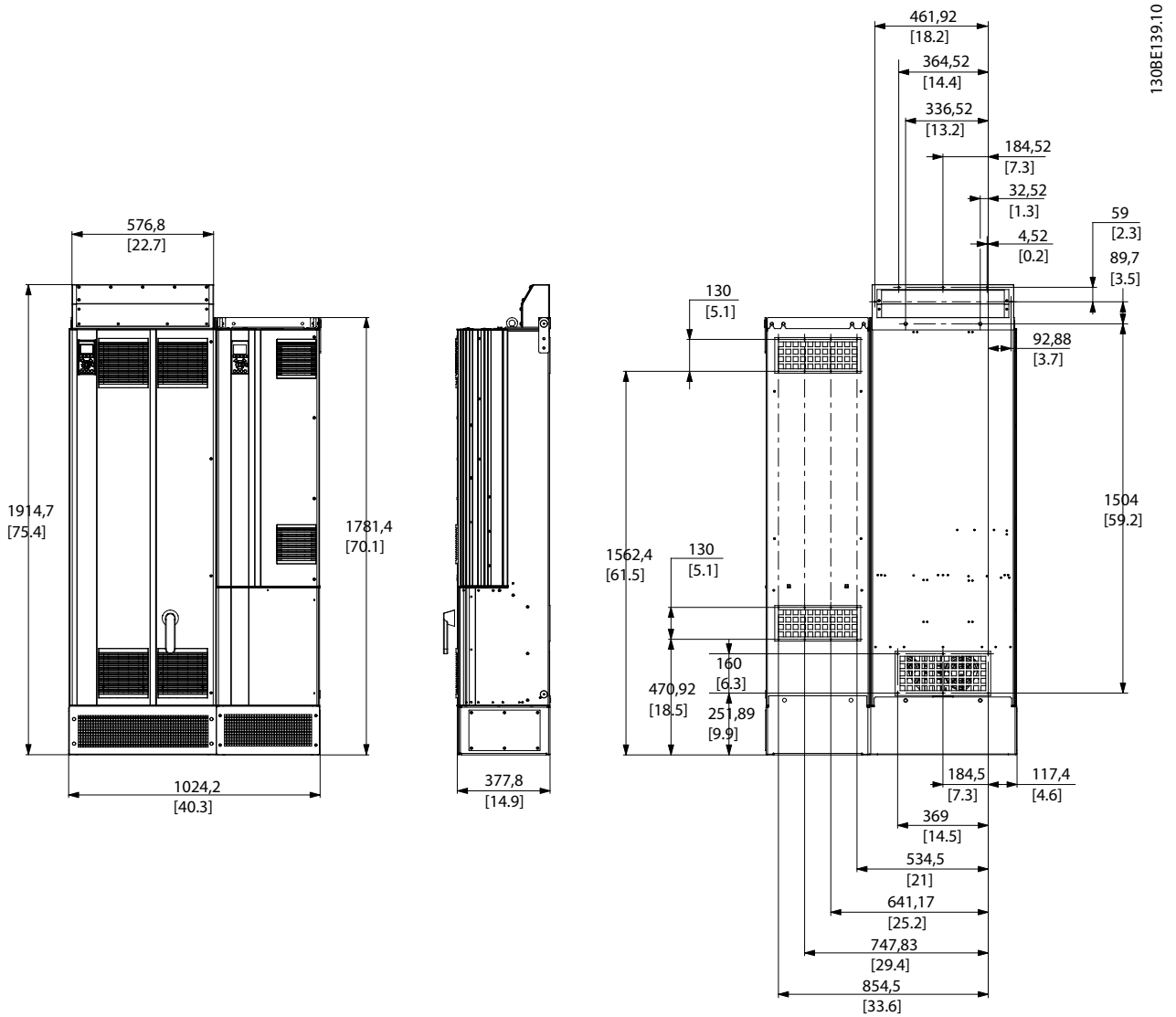

Illustration 8.10 Enclosure Size D2n

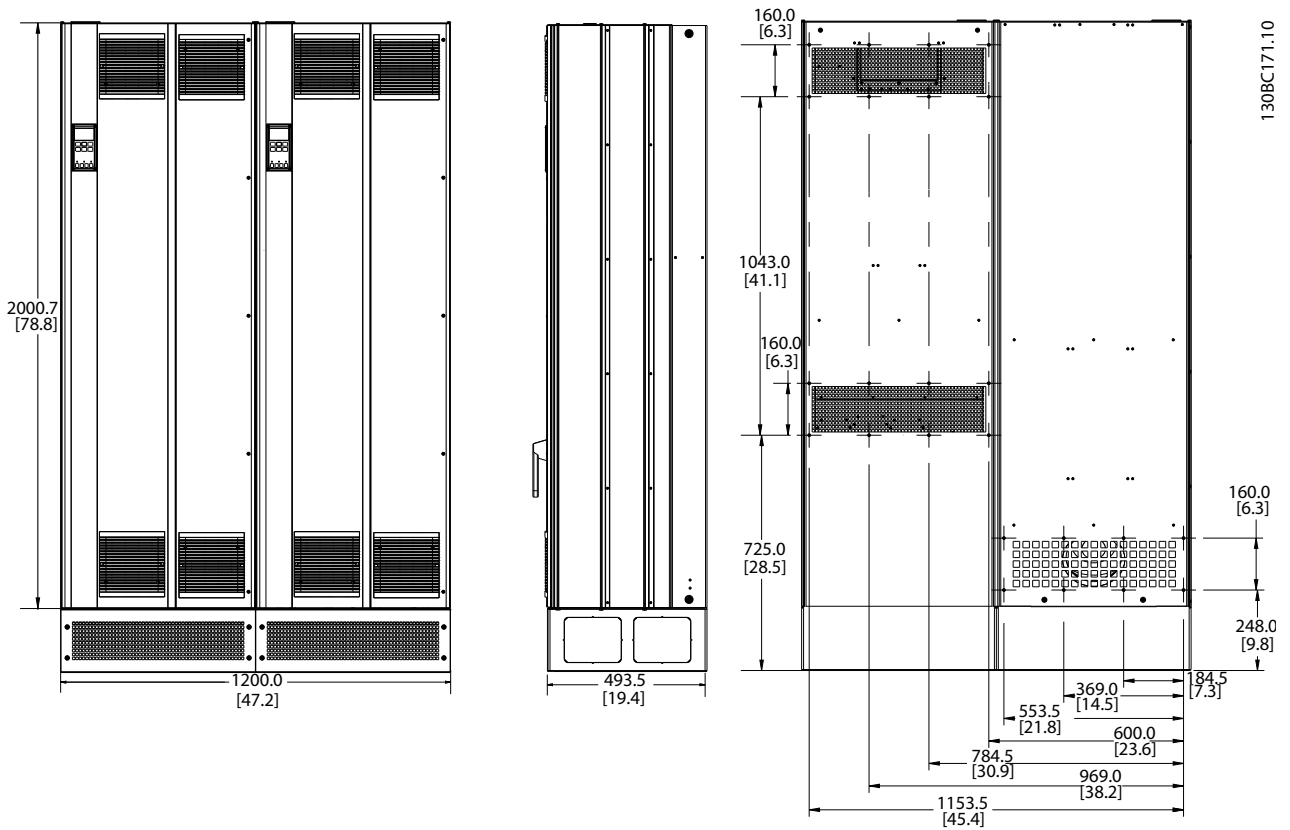

Illustration 8.11 Enclosure Size E9

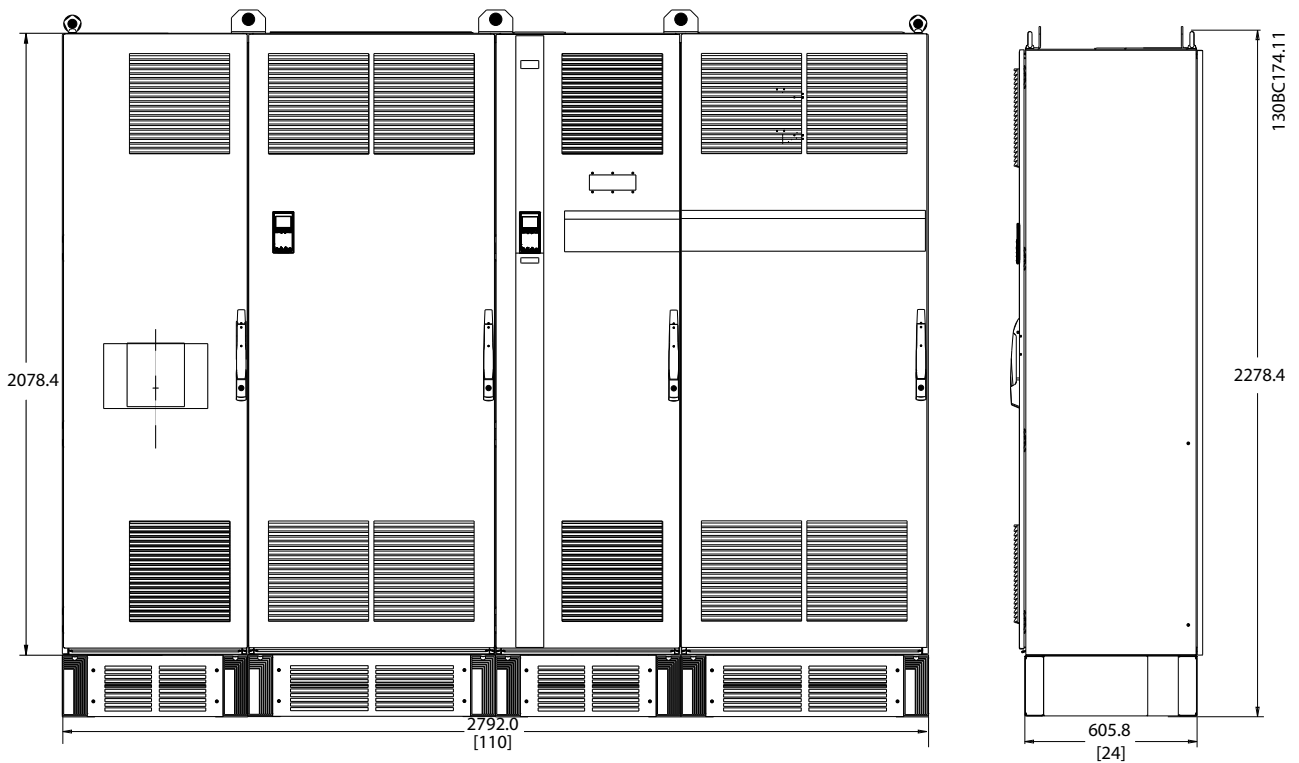

Illustration 8.12 Enclosure Size F18, Front and Side View

8.3 General Technical Data

Mains supply (L1, L2, L3)

Supply voltage	380–480 V +5%
----------------	---------------

Mains voltage low/mains drop-out:

During low mains voltage or mains drop-out, the frequency converter continues until the intermediate circuit voltage drops below the minimum stop level, corresponding to 15% below the lowest rated supply voltage. Power-up and full torque cannot be expected at mains voltage lower than 10% below the lowest rated supply voltage.

Supply frequency	50/60 Hz ±5%
------------------	--------------

Maximum imbalance temporary between mains phases	3.0% of rated supply voltage
--	------------------------------

True power factor (λ)	>0.98 nominal at rated load
---------------------------------	-----------------------------

Displacement power factor ($\cos\phi$) near unity	(>0.98)
---	---------

THDi	<5%
------	-----

Switching on input supply L1, L2, L3 (power-ups)	maximum once/2 minutes
--	------------------------

Environment according to EN60664-1	overvoltage category III/pollution degree 2
------------------------------------	---

The unit is suitable for use on a circuit capable of delivering not more than 100000 RMS symmetrical Amperes, 480/690 V maximum.

Motor output (U, V, W)

Output voltage	0–100% of supply voltage
----------------	--------------------------

Output frequency	0–590 Hz ¹⁾
------------------	------------------------

Switching on output	Unlimited
---------------------	-----------

Ramp times	0.01–3600 s
------------	-------------

1) Voltage and power dependent

Torque characteristics

Starting torque (constant torque)	maximum 150% for 60 s ¹⁾
-----------------------------------	-------------------------------------

Starting torque	maximum 180% up to 0.5 s ¹⁾
-----------------	--

Overload torque (constant torque)	maximum 150% for 60 s ¹⁾
-----------------------------------	-------------------------------------

1) Percentage relates to nominal torque of the unit.

Cable lengths and cross-sections

Maximum motor cable length, screened/armoured	150 m
---	-------

Maximum motor cable length, unscreened/unarmoured	300 m
---	-------

Maximum cross-section to motor, mains, load sharing, and brake ¹⁾	
--	--

Maximum cross-section to control terminals, rigid wire	1.5 mm ² /16 AWG (2 x 0.75 mm ²)
--	---

Maximum cross-section to control terminals, flexible cable	1 mm ² /18 AWG
--	---------------------------

Maximum cross-section to control terminals, cable with enclosed core	0.5 mm ² /20 AWG
--	-----------------------------

Minimum cross-section to control terminals	0.25 mm ²
--	----------------------

1) See chapter 8.1.1 Mains Supply 3x380–480 V AC for more information

Digital inputs

Programmable digital inputs	4 (6) on frequency converter and 2 (4) on active filter
-----------------------------	---

Terminal number	18, 19, 27 ¹⁾ , 29 ¹⁾ , 32, and 33
-----------------	--

Logic	PNP or NPN
-------	------------

Voltage level	0–24 V DC
---------------	-----------

Voltage level, logic 0 PNP	<5 V DC
----------------------------	---------

Voltage level, logic 1 PNP	>10 V DC
----------------------------	----------

Voltage level, logic 0 NPN	>19 V DC
----------------------------	----------

Voltage level, logic 1 NPN	<14 V DC
----------------------------	----------

Maximum voltage on input	28 V DC
--------------------------	---------

Input resistance, R _i	approximately 4 k Ω
----------------------------------	----------------------------

All digital inputs are galvanically isolated from the supply voltage (PELV) and other high-voltage terminals.

1) Terminals 27 and 29 can also be programmed as output.

Analog inputs

Number of analog inputs	2 on frequency converter
Terminal number	53 and 54
Modes	Voltage or current
Mode select	Switch S201 and switch S202, Switch A53 and A54
Voltage mode	Switch S201/switch S202 = OFF (U), Switch A53 and A54
Voltage level	0–10 V (scaleable)
Input resistance, R_i	approximately 10 k Ω
Maximum voltage	± 20 V
Current mode	Switch S201/switch S202 = ON (I), switch A53 and A54
Current level	0/4 to 20 mA (scaleable)
Input resistance, R_i	approximately 200 Ω
Maximum current	30 mA
Resolution for analog inputs	10 bit (+ sign)
Accuracy of analog inputs	Maximum error 0.5% of full scale
Bandwidth	100 Hz (D-frame), 200 Hz

The analog inputs are galvanically isolated from the supply voltage (PELV) and other high-voltage terminals.

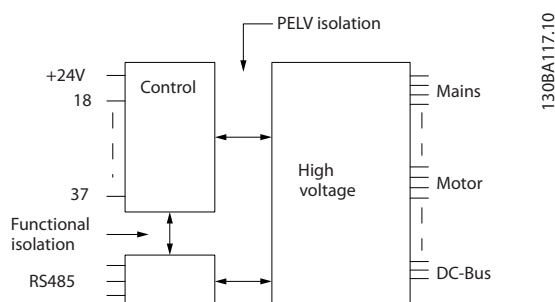

Illustration 8.13 PELV Isolation of Analog Inputs

Pulse inputs

Programmable pulse inputs	2 on frequency converter
Terminal number pulse	29 and 33
Maximum frequency at terminal, 29 and 33	110 kHz (push-pull driven)
Maximum frequency at terminal, 29 and 33	5 kHz (open collector)
Minimum frequency at terminal 29 and 33	4 Hz
Voltage level	see chapter 8.3.1 Digital inputs
Maximum voltage on input	28 V DC
Input resistance, R_i	approximately 4 k Ω
Pulse input accuracy (0.1–1 kHz)	Maximum error: 0.1% of full scale

Analog output

Number of programmable analog outputs	1 on both frequency converter and active filter
Terminal number	42
Current range at analog output	0/4–20 mA
Maximum resistor load to common at analog output	500 Ω
Accuracy on analog output	Maximum error: 0.8% of full scale
Resolution on analog output	8 bit

The analog output is galvanically isolated from the supply voltage (PELV) and other high-voltage terminals.

Control card, RS485 serial communication

Terminal number	68 (PTX+, RX+) and 69 (N, TX-, RX-)
Terminal number 61	Common for terminals 68 and 69

The RS485 serial communication circuit is functionally separated from other central circuits and galvanically isolated from the supply voltage (PELV).

Digital output

Programmable digital/pulse outputs	2 on both frequency converter and active filter
Terminal number	27 and 29 ¹⁾
Voltage level at digital/frequency output	0–24 V
Maximum output current (sink or source)	40 mA
Maximum load at frequency output	1 kΩ
Maximum capacitive load at frequency output	10 nF
Minimum output frequency at frequency output	0 Hz
Maximum output frequency at frequency output	32 kHz
Accuracy of frequency output	Maximum error: 0.1% of full scale
Resolution of frequency outputs	12 bit

1) Terminals 27 and 29 can also be programmed as input.

The digital output is galvanically isolated from the supply voltage (PELV) and other high-voltage terminals.

Control card, 24 V DC output

Terminal number	13
Output voltage	24 V (+1, -3 v)
Maximum load	200 mA

The 24 V DC supply is galvanically isolated from the supply voltage (PELV), but has the same potential as the analog and digital inputs and outputs.

Relay outputs

Programmable relay outputs	2 on frequency converter only
Relay 01 Terminal number (D-frame)	1–3 (break), 1–2 (make)
Maximum terminal load (AC-1) ¹⁾ on 1–2 (NO) (Resistive load) ²⁾³⁾	400 V AC, 2 A
Maximum terminal load (AC-15) ¹⁾ on 1–2 (NO) (Inductive load @ cosφ 0.4)	240 V AC, 0.2 A
Maximum terminal load (DC-1) ¹⁾ on 1–2 (NO) (Resistive load)	80 V DC, 2 A
Maximum terminal load (DC-13) ¹⁾ on 1–2 (NO) (Inductive load)	24 V DC, 0.1 A
Maximum terminal load (AC-1) ¹⁾ on 1–3 (NC) (Resistive load)	240 V AC, 2 A
Maximum terminal load (AC-15) ¹⁾ on 1–3 (NC) (Inductive load @ cosφ 0.4)	240 V AC, 0.2 A
Maximum terminal load (DC-1) ¹⁾ on 1–3 (NC) (Resistive load)	50 V DC, 2 A
Maximum terminal load (DC-13) ¹⁾ on 1–3 (NC) (Inductive load)	24 V DC, 0.1 A
Minimum terminal load on 1–3 (NC), 1–2 (NO)	24 V DC 10 mA, 24 V AC 2 mA
Environment according to EN 60664-1	overvoltage category III/pollution degree 2
Relay 01 terminal number (E-frame and F-frame)	1–3 (break), 1–2 (make)
Maximum terminal load (AC-1) ¹⁾ on 1–3 (NC), 1–2 (NO) (resistive load)	240 V AC, 2A
Maximum terminal load (AC-15) ¹⁾ (inductive load @ cosφ 0.4)	240 V AC, 0.2 A
Maximum terminal load (DC-1) ¹⁾ on 1–2 (NO), 1–3 (NC) (resistive load)	60 V DC, 1 A
Maximum terminal load (DC-13) ¹⁾ (inductive load)	24 V DC, 0.1 A
Relay 02 terminal number	4–6 (break), 4–5 (make)
Maximum terminal load (AC-1) ¹⁾ on 4–5 (NO) (resistive load) ²⁾³⁾	400 V AC, 2 A
Maximum terminal load (AC-15) ¹⁾ on 4–5 (NO) (inductive load @ cosφ 0.4)	240 V AC, 0.2 A
Maximum terminal load (DC-1) ¹⁾ on 4–5 (NO) (resistive load)	80 V DC, 2 A
Maximum terminal load (DC-13) ¹⁾ on 4–5 (NO) (inductive load)	24 V DC, 0.1 A
Maximum terminal load (AC-1) ¹⁾ on 4–6 (NC) (resistive load)	240 V AC, 2 A
Maximum terminal load (AC-15) ¹⁾ on 4–6 (NC) (inductive load @ cosφ 0.4)	240 V AC, 0.2 A
Maximum terminal load (DC-1) ¹⁾ on 4–6 (NC) (resistive load)	50 V DC, 2 A
Maximum terminal load (DC-13) ¹⁾ on 4–6 (NC) (inductive load)	24 V DC, 0.1 A
Minimum terminal load on 1–3 (NC), 1–2 (NO), 4–6 (NC), 4–5 (NO)	24 V DC 10 mA, 24 V AC 20 mA
Environment according to EN 60664-1	overvoltage category III/pollution degree 2

1) IEC 60947 parts 4 and 5.

The relay contacts are galvanically isolated from the rest of the circuit by reinforced isolation (PELV).

2) Overvoltage Category II.

3) UL applications 300 V AC 2 A.

Control characteristics

Resolution of output frequency at 0–1000 Hz	±0.003 Hz
System response time (terminals 18, 19, 27, 29, 32, and 33)	≤2 ms
Speed control range (open loop)	1:100 of synchronous speed
Speed accuracy (open loop)	30–4000 RPM: Maximum error of ±8 RPM

All control characteristics are based on a 4-pole asynchronous motor.

Surroundings

Enclosure protection rating, enclosure sizes D and E	IP21, IP54
Enclosure protection rating, enclosure size F	IP21, IP54
Vibration test	0.7 g
Relative humidity	5–95% (IEC 721-3-3; Class 3K3 (non-condensing) during operation
Aggressive environment (IEC 60068-2-43) H ₂ S test	class kD
Test method according to IEC 60068-2-43 H ₂ S (10 days)	
Ambient temperature (at 60 AVM switching mode)	
- with derating	maximum 55 °C
- with full output power, typical IE2 motors (see <i>chapter 8.1.2 Derating for Temperature</i>)	maximum 50 °C
- at full continuous FC output current	maximum 45 °C
Minimum ambient temperature during full-scale operation	0 °C
Minimum ambient temperature at reduced performance	- 10 °C
Temperature during storage/transport	-25 to +65/70 °C
Maximum altitude above sea level without derating	1000 m
Maximum altitude above sea level with derating	3000 m

For more information on derating, consult the design guide.

EMC standards, emission	EN 61800-3, EN 61000-6-3/4, EN 55011, IEC 61800-3 EN 61800-3, EN 61000-6-1/2,
EMC standards, immunity	EN 61000-4-2, EN 61000-4-3, EN 61000-4-4, EN 61000-4-5, EN 61000-4-6

Control card performance

Scan interval	1 ms
---------------	------

Control card, USB serial communication

USB standard	1.1 (full speed)
USB plug	USB type B device plug

NOTICE

Connection to PC is carried out via a standard host/device USB cable.

The USB connection is galvanically isolated from the supply voltage (PELV) and other high-voltage terminals.

The USB connection is not galvanically isolated from protective earth. Use only an isolated laptop/PC as connection to the USB connector on the frequency converter or an isolated USB cable/converter.

Protection and features:

- Electronic thermal motor protection against overload.
- Temperature monitoring of the heat sink ensures that the frequency converter trips if the temperature reaches a predefined level. An overload temperature cannot be reset until the temperature of the heat sink is below the allowed values.
- The frequency converter is protected against short circuits on motor terminals U, V, W.
- If a mains phase is missing, the frequency converter trips or issues a warning (depending on the load).
- Monitoring of the DC-link voltage ensures that the frequency converter trips if the intermediate circuit voltage is too low or too high.
- The frequency converter is protected against ground faults on motor terminals U, V, W.

Power Ranges (LHD with AF)

Response time	< 0.5 ms
Settling time - reactive current control	< 40 ms
Settling time - harmonic current control (filtering)	< 20 ms
Overshoot - reactive current control	< 20%
Overshoot - harmonic current control	< 10%

Grid conditions

Supply voltage	380–480 V, +5%/-10%
----------------	---------------------

Mains voltage low/mains drop-out:

During low mains voltage or a mains drop-out, the filter continues until the DC-link voltage drops below the minimum stop level, which corresponds to 15% below the filter lowest rated supply voltage. Full compensation cannot be expected at mains voltage lower than 10% below the filter lowest rated supply voltage. If mains voltage exceeds the filter highest rated voltage, the filter continues to work but harmonic mitigation performance is reduced. The filter does not cut out until main voltages exceed 580 V.

Supply frequency	50/60 Hz ±5%
	3.0% of rated supply voltage

Maximum imbalance temporary between mains phases where mitigation performance is kept high.	Filter mitigates at higher mains imbalance but harmonic mitigation performance is reduced
	10% with kept mitigation performance

Maximum THDv pre-distortion	Reduced performance for higher pre-distortion levels
-----------------------------	--

Harmonic mitigation performance

	Best performance <4%
THiD	Depending on filter vs. distortion ratio.
Individual harmonic mitigation ability:	Current maximum RMS [% of rated RMS current]
2nd	10%
4th	10%
5th	70%
7th	50%
8th	10%
10th	5%
11th	32%
13th	28%
14th	4%
16th	4%
17th	20%
19th	18%
20th	3%
22nd	3%
23rd	16%
25th	14%
Total current of harmonics	90%

The filter is performance tested to the 40th order

Reactive current compensation

Cos phi	Lagging and leading, depending on parameter settings
Cos phi	Controllable 1.0 to 0.5 lagging
Reactive current, % of filter current rating	100%

Generic specifications

Filter efficiency	97%
Typical average switching frequency	3.0–4.5 kHz
Response time (reactive and harmonic)	<0.5 ms
Settling time - reactive current control	<20 ms
Settling time - harmonic current control	<20 ms
Overshoot - reactive current control	<10%
Overshoot - Harmonic current control	<10%

8.3.1 Derating for Altitude

The cooling capability of air is decreased at lower air pressure.

Below 1000 m altitude no derating is necessary, but above 1000 m derate the ambient temperature (T_{AMB}) or maximum output current (I_{out}) in accordance with *Illustration 8.14*.

An alternative is to lower the ambient temperature at high altitudes and thereby ensure 100% output current at high altitudes. As an example of how to read the graph, the situation at 2000 m is elaborated. At a temperature of 45 °C ($T_{AMB, MAX} - 3.3 K$), 91% of the rated output current is available. At a temperature of 41.7 °C, 100% of the rated output current is available.

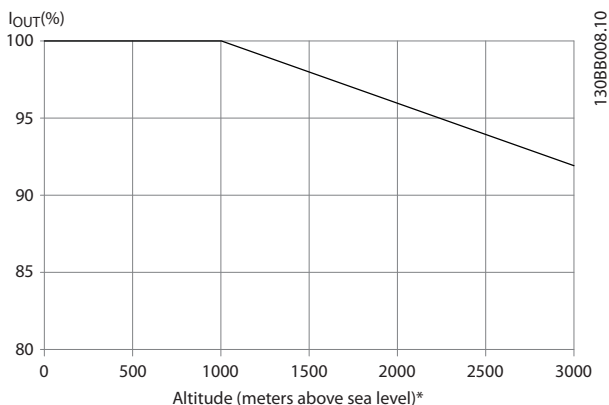

Illustration 8.14 Altitude Derating

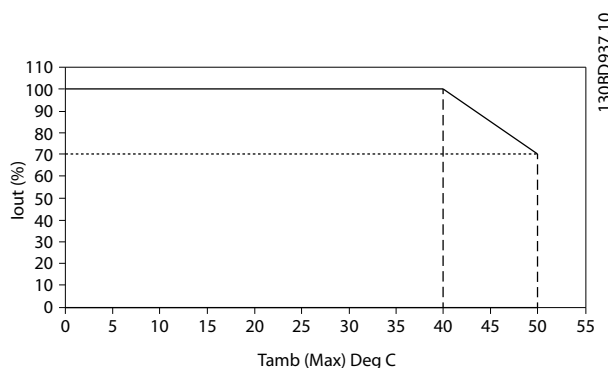

Illustration 8.15 Input/Output vs. Maximum Ambient Temperature

8.4 Fuses

Danfoss recommends using fuses and/or circuit breakers on the supply side as protection in case of component break-down inside the frequency converter (first fault).

NOTICE

Using fuses and/or circuit breakers ensures compliance with IEC 60364 for CE or NEC 2009 for UL.

Branch circuit protection

To protect the installation against electrical and fire hazard, all branch circuits in an installation, switch gear, machines, and so on, must be protected against short-circuit and overcurrent according to national/international regulations.

NOTICE

The recommendations do not cover branch circuit protection for UL.

Short-circuit protection

Danfoss recommends using the fuses/circuit breakers in *chapter 8.4.2 Fuse Tables* to protect service personnel and property in case of component break-down in the frequency converter.

8.4.1 Non-UL Compliance

N132-N200	380-500 V	type gG
P250-P400	380-500 V	type gR

Non-UL compliance

If UL/cUL is not to be complied with, Danfoss recommends using the following fuses, which ensure compliance with EN50178:

Table 8.4 Recommended Fuses for non-UL Applications

8.4.2 Fuse Tables

UL Compliance

380-480 V, enclosure sizes D, E, and F

The fuses below are suitable for use on a circuit capable of delivering 100,000 Arms (symmetrical). With the proper fusing, the frequency converter short circuit current rating (SCCR) is 100000 Arms.

Size/Type [kW]	Bussmann	LittelFuse	LittelFuse PN	Bussmann PN	Siba PN	Ferraz/Shawmut Europ	Ferraz-Shawmut NA	Ferraz-Shawmut PN
132	170M4012	LA50QS400-4	L50S-400	FWH-400A	20 610 31.400	6,9URD31D08A0400	A070URD31KI0400	A50QS400-4
160	170M4015	LA50QS500-4	L50S-500	FWH-500A	20 610 31.550	6,9URD31D08A0550	A070URD31KI0550	A50QS500-4
200	170M5012	LA50QS600-4	L50S-600	FWH-600A	20 610 31.630	6,9URD31D08A0630	A070URD31KI0630	A50QS600-4

Table 8.5 Enclosure size D, Mains Fuses, 380-480 V

Size/Type [kW]	Bussmann PN ¹⁾	Rating	Ferraz	Siba
250	170M4017	700 A, 700 V	6.9URD33D08A0700	20 630 32.700
315	170M6013	900 A, 700 V	6.9URD33D08A0900	20 630 32.900
355	170M6013	900 A, 700 V	6.9URD33D08A0900	20 630 32.900
400	170M6013	900 A, 700 V	6.9URD33D08A0900	20 630 32.900

Table 8.6 Enclosure size E, Mains Fuses, 380-480 V

Size/Type [kW]	Bussmann PN ¹⁾	Rating	Siba	Internal Bussmann option
450	170M7081	1600 A, 700 V	20 695 32.1600	170M7082
500	170M7081	1600 A, 700 V	20 695 32.1600	170M7082
560	170M7082	2000 A, 700 V	20 695 32.2000	170M7082
630	170M7082	2000 A, 700 V	20 695 32.2000	170M7082

Table 8.7 Enclosure size F, Mains Fuses, 380-480 V

Size/Type [kW]	Bussmann PN ¹⁾	Rating	Siba
450	170M8611	1100 A, 1000 V	20 781 32.1000
500	170M8611	1100 A, 1000 V	20 781 32.1000
560	170M6467	1400 A, 700 V	20 681 32.1400
630	170M6467	1400 A, 700 V	20 681 32.1400

Table 8.8 Enclosure Size F, Inverter Module DC-link Fuses, 380-480 V

1) 170M fuses from Bussmann shown use the -/80 visual indicator, -TN/80 Type T, -/110 or TN/110 Type T indicator fuses of the same size and amperage may be substituted for external use.

8.4.3 Supplementary Fuses

Supplementary fuses

Enclosure size	Bussmann PN	Rating
D, E, and F	KTK-4	4 A, 600 V

Table 8.9 SMPS Fuse

Size/Type	Bussmann PN	Littelfuse	Rating
315-630 kW, 380-500 V		KLK-15	15 A, 600 V

Table 8.10 Fan Fuses

Size/Type		Bussmann PN	Rating	Alternative fuses
450-630 kW, 380-500 V	2.5-4.0 A	LPJ-6 SP or SPI	6 A, 600 V	Any listed class J dual element, time delay, 6A
450-630 kW, 380-500 V	4.0-6.3 A	LPJ-10 SP or SPI	10 A, 600 V	Any listed class J dual element, time delay, 10 A
450-630 kW, 380-500 V	6.3-10 A	LPJ-15 SP or SPI	15 A, 600 V	Any listed class J dual element, time delay, 15 A
450-630 kW, 380-500 V	10-16 A	LPJ-25 SP or SPI	25 A, 600 V	Any listed class J dual element, time delay, 25 A

Table 8.11 Manual Motor Controller Fuses

Enclosure size	Bussmann PN ¹⁾	Rating	Alternative fuses
F	LPJ-30 SP or SPI	30 A, 600 V	Any listed Class J dual element, time delay, 30 A

Table 8.12 30 A Fuse Protected Terminal Fuse

Enclosure size	Bussmann PN ¹⁾	Rating	Alternative fuses
F	LPJ-6 SP or SPI	6 A, 600 V	Any listed class J dual element, time delay, 6 A

Table 8.13 Control Transformer Fuse

Frame size	Bussmann PN ¹⁾	Rating
F	GMC-800MA	800 mA, 250 V

Table 8.14 NAMUR Fuse

Enclosure size	Bussmann PN ¹⁾	Rating	Alternative fuses
F	LP-CC-6	6 A, 600 V	Any listed class CC, 6 A

Table 8.15 Safety Relay Coil Fuse with PILS Relay

Enclosure size	Littelfuse PN	Rating
D, E, F	KLK-15	15 A, 600 V

Table 8.16 Mains Fuses (Power Card)

Enclosure size	Bussmann PN	Rating
D, E, F	FNQ-R-3	3 A, 600 V

Table 8.17 Transformer Fuse (Mains Contactor)

Enclosure size	Bussmann PN	Rating
D, E, F	FNQ-R-1	1 A, 600 V

Table 8.18 Soft Charge Fuses

1) 170M fuses from Bussmann shown use the -/80 visual indicator, -TN/80 Type T, -/110 or TN/110 Type T indicator fuses of the same size and amperage may be substituted for external use.

8.5 General Torque Tightening Values

For fastening hardware described in this manual, use the torque values in *Table 8.19*. These values are not intended for fastening IGBTs. See the instructions included with those replacement parts for correct values.

Shaft size	Driver size Torx/Hex [mm]	Torque [Nm]	Torque [in-lbs]
M4	T-20/7	1.0	10
M5	T-25/8	2.3	20
M6	T-30/10	4.0	35
M8	T-40/13	9.6	85
M10	T-50/17	19.2	170
M12	18/19	19	170

Table 8.19 Torque Values

9 Appendix A - Parameters

9.1 Description of Parameters

9.1.1 Main Menu

The main menu includes all available parameters in the frequency converter. All parameters are grouped by name indicating the function of the parameter group. All parameters are listed by name and number in this manual.

9.2 Frequency Converter Parameter Lists

0-0*	Operation / Display	Motor Model	1-11	Motor Model	3-01	Reference/Feedback Unit	3-95	Ramp Delay
0-0*	Basic Settings	Damping Gain	1-14	Damping Gain	1-75	Start Speed [Hz]	4-*	Limits / Warnings
0-01	Language	Low Speed Filter Time Const.	1-15	Start Current	1-76	Start Current	4-1*	Motor Limits
0-02	Motor Speed Unit	High Speed Filter Time Const.	1-16	Stop Adjustments	1-8*	Function at Stop	4-10	Motor Speed Direction
0-03	Regional Settings	Voltage filter time const.	1-17	1-80	1-80	Function at Stop [RPM]	4-11	Motor Speed Low Limit [RPM]
0-04	Operating State at Power-up (Hand)	Min. Current at No Load	1-18	1-81	1-81	Min Speed for Function at Stop [Hz]	4-12	Motor Speed Low Limit [Hz]
0-09	Performance Monitor	Motor Data	1-2*	1-82	1-82	Min Speed for Function at Stop [Hz]	4-13	Motor Speed High Limit [RPM]
0-10	Active Set-up	Motor Power [kW]	1-20	1-83	1-83	Precise Stop Counter Value	4-14	Motor Speed High Limit [Hz]
0-11	Edit Set-up	Motor Power [HP]	1-21	1-84	1-84	Precise Stop Counter Value	4-16	Torque Limit Motor Mode
0-12	This Set-up Linked to	Motor Voltage	1-22	1-85	1-85	Precise Stop Speed Compensation	4-17	Torque Limit Generator Mode
0-13	Readout: Linked Set-ups	Motor Frequency	1-23	1-9*	1-9*	Motor Temperature	4-18	Current Limit
0-14	Readout: Edit Set-ups / Channel	Motor Current	1-24	1-90	1-90	Motor Thermal Protection	4-19	Max Output Frequency
0-15	Readout: actual setup	Motor Nominal Speed	1-25	1-91	1-91	Motor External Fan	4-2*	Limit Factors
0-2*	LCP Display	Motor Cont. Rated Torque	1-26	1-93	1-93	Thermistor Resource	4-20	Torque Limit Factor Source
0-20	Display Line 1.1 Small	Automatic Motor Adaptation (AMA)	1-29	1-94	1-94	ATEX ETR cur.lim. speed reduction	4-21	Speed Limit Factor Source
0-21	Display Line 1.2 Small	Adv. Motor Data	1-3*	1-95	1-95	KTY Sensor Type	4-23	Brake Check Limit Factor Source
0-22	Display Line 1.3 Small	Stator Resistance (Rs)	1-30	1-96	1-96	KTY Thermistor Resource	4-24	Brake Check Limit Factor
0-24	Display Line 2 Large	Rotor Resistance (Rr)	1-31	1-97	1-97	KTY Threshold level	4-3*	Motor Speed Mon.
0-25	My Personal Menu	Stator Leakage Reactance (X1)	1-33	1-98	1-98	ATEX ETR interpol. points freq.	4-30	Motor Feedback Loss Function
0-3*	LCP Custom Readout	Rotor Leakage Reactance (X2)	1-34	1-99	1-99	ATEX ETR interpol. points current	4-31	Motor Feedback Speed Error
0-30	Unit for User-defined Readout	Main Reactance (Xh)	1-35	2-*	2-*	Brakes	4-32	Motor Feedback Loss Timeout
0-31	Min Value of User-defined Readout	Iron Loss Resistance (Rfe)	1-36	2-00	2-00	DC-Brake	4-34	Tracking Error Function
0-32	Max Value of User-defined Readout	d-axis Inductance (Ld)	1-37	2-01	2-01	DC Hold Current	4-36	Tracking Error Timeout
0-37	Display Text 1	d-axis Inductance (Lq)	1-38	2-02	2-02	DC Brake Current	4-37	Tracking Error Ramping
0-38	Display Text 2	Motor Poles	1-39	2-03	2-03	DC Braking Time	4-38	Tracking Error Ramping Timeout
0-39	Display Text 3	Back EMF at 1000 RPM	1-40	2-04	2-04	DC Brake Cut In Speed [RPM]	4-39	Tracking Error After Ramping Timeout
0-4*	LCP keypad	Motor Angle Offset	1-41	2-05	2-05	DC Brake Cut In Speed [Hz]	4-5*	Adj. Warnings
0-40	[Hand on] Key on LCP	d-axis Inductance Sat. (LdSat)	1-44	2-06	2-06	Maximum Reference	4-50	Warning Current Low
0-41	[Off] Key on LCP	q-axis Inductance Sat. (LqSat)	1-45	2-07	2-07	Parking Current	4-51	Warning Current High
0-42	[Auto on] Key on LCP	Position Detection Gain	1-46	2-08	2-08	Brake Energy Funct.	4-52	Warning Speed Low
0-43	[Reset] Key on LCP	Torque Calibration	1-47	2-09	2-09	Brake Resistor (ohm)	4-53	Warning Speed High
0-44	[Off/Reset] Key on LCP	Inductance Sat. Point	1-48	2-10	2-10	Brake Function	4-54	Warning Reference Low
0-45	[Drive Bypass] Key on LCP	Load Indep. Setting	1-5*	2-11	2-11	Brake Resistor (ohm)	4-55	Warning Reference High
0-50	LCP Copy	Motor Magnetisation at Zero Speed	1-50	2-12	2-12	Brake Power Limit (kW)	4-56	Warning Feedback Low
0-51	Set-up Copy	Min Speed Normal Magnetising [RPM]	1-51	2-13	2-13	Brake Power Monitoring	4-57	Warning Feedback High
0-52	Main Menu Password	Min Speed Normal Magnetising [Hz]	1-52	2-14	2-14	Brake Check	4-58	Missing Motor Phase Function
0-53	Access to Main Menu w/o Password	Model Shift Frequency	1-53	2-15	2-15	AC brake Max. Current	4-6*	Speed Bypass
0-54	Access to Quick Menu w/o Password	Voltage reduction in fieldweakening	1-54	2-16	2-16	Over-voltage Control	4-60	Bypass Speed From [RPM]
0-55	Bus Password Access	U/f Characteristic - U	1-55	2-17	2-17	Brake Check Condition	4-61	Bypass Speed To [RPM]
0-56	Safety Parameters Password	U/f Characteristic - F	1-56	2-18	2-18	Over-voltage Gain	4-62	Bypass Speed To [Hz]
0-57	Password Protection of Safety Parameters	Flying Start Test Pulses Current	1-57	2-19	2-19	Mechanical Brake	5-*	Digital In/Out
1-*	Load and Motor	Flying Start Test Pulses Frequency	1-58	2-20	2-20	Release Brake Current	5-0*	Digital I/O mode
1-0*	Configuration Mode	Load Depen. Setting	1-6*	2-21	2-21	Activate Brake Speed [RPM]	5-00	Digital I/O Mode
1-01	Motor Control Principle	Low Speed Load Compensation	1-60	2-22	2-22	Activate Brake Speed [Hz]	5-01	Terminal 27 Mode
1-02	Flux Motor Feedback Source	Slip Compensation	1-61	2-23	2-23	Activate Brake Delay	5-02	Terminal 29 Mode
1-03	Torque Characteristics	Slip Compensation Time Constant	1-62	2-24	2-24	Stop Delay	5-02	Terminal 29 Mode
1-04	Overload Mode	Resonance Damping	1-63	2-25	2-25	Brake Release Time	5-1*	Digital Inputs
1-05	Local Mode Configuration	Resonance Damping Time Constant	1-64	2-26	2-26	Torque Ref	5-10	Terminal 18 Digital Input
1-06	Clockwise Direction	Min. Current at Low Speed	1-65	2-27	2-27	Torque Ramp Up Time	5-11	Terminal 19 Digital Input
1-07	Motor Angle Offset Adjust	Load Type	1-66	2-28	2-28	Gain Boost Factor	5-12	Terminal 27 Digital Input
1-1*	Motor Construction	Motor Inertia	1-68	2-29	2-29	Torque Ramp Down Time	5-13	Terminal 29 Digital Input
1-10	Motor Construction	System Inertia	1-69	2-30	2-30	Brake Release Time	5-14	Terminal 32 Digital Input
		Start Adjustments	1-7*	2-31	2-31	Proportional Gain	5-15	Terminal 33 Digital Input
		PM Start Mode	1-70	2-32	2-32	Speed PID Start Proportional Gain	5-16	Terminal X30/2 Digital Input
		Start Function	1-71	2-33	2-33	Speed PID Start Integral Time	5-17	Terminal X30/3 Digital Input
		Flying Start	1-72	3-*	3-*	Speed PID Start Lowpass Filter Time	5-18	Terminal X30/4 Digital Input
		Start Speed [RPM]	1-74	3-00	3-00	Reference Range	5-19	Terminal 37 Safe Stop
				3-00	3-00	Reference Limits	5-20	Terminal X46/1 Digital Input



5-21	Terminal X46/3 Digital Input	6-20	Terminal 54 Low Voltage	7-13	Torque PI Integration Time	8-37	Max Inter-Char Delay	9-85	Defined Parameters (6)
5-22	Terminal X46/5 Digital Input	6-21	Terminal 54 High Voltage	7-16	Torque PI Lowpass Filter Time	8-4*	FC MC protocol set	9-90	Changed Parameters (1)
5-23	Terminal X46/7 Digital Input	6-22	Terminal 54 Low Current	7-18	Torque PI Feed Forward Factor	8-40	Telegram Selection	9-91	Changed Parameters (2)
5-24	Terminal X46/9 Digital Input	6-23	Terminal 54 High Current	7-19	Current Controller Rise Time	8-41	Parameters for Signals	9-92	Changed Parameters (3)
5-25	Terminal X46/11 Digital Input	6-24	Terminal 54 Low Ref./Feedb. Value	7-2*	Process Ctrl. Feedb	8-42	PCD Write Configuration	9-93	Changed Parameters (4)
5-26	Terminal X46/13 Digital Input	6-25	Terminal 54 High Ref./Feedb. Value	7-20	Process CL Feedback 1 Resource	8-43	PCD Read Configuration	9-94	Changed Parameters (5)
5-3*	Digital Outputs	6-26	Terminal 54 Filter Time Constant	7-22	Process CL Feedback 2 Resource	8-45	BTM Transaction Command	10-10*	CAN Fieldbus
5-30	Terminal 27 Digital Output	6-3*	Analog Input 3	7-3	Process PID Ctrl.	8-46	BTM Transaction Status	10-0*	Common Settings
5-31	Terminal 29 Digital Output	6-30	Terminal X30/11 Low Voltage	7-30	Process PID Normal/ Inverse Control	8-47	BTM Timeout	10-00	CAN Protocol
5-32	Term X30/6 Digi Out (MCB 101)	6-31	Terminal X30/11 High Voltage	7-31	Process PID Anti Windup	8-48	BTM Maximum Errors	10-01	Baud Rate Select
5-33	Term X30/7 Digi Out (MCB 101)	6-34	Term. X30/11 Low Ref./Feedb. Value	7-32	Process PID Start Speed	8-49	BTM Error Log	10-02	MAC ID
5-4*	Relays	6-35	Term. X30/11 High Ref./Feedb. Value	7-33	Process PID Proportional Gain	8-5*	Digital/Bus	10-05	Readout Transmitter Error Counter
5-40	Function Relay	6-36	Term. X30/11 Filter Time Constant	7-34	Process PID Integral Time	8-50	Coasting Select	10-06	Readout Receiver Error Counter
5-41	On Delay, Relay	6-4*	Analog Input 4	7-35	Process PID Differentiation Time	8-51	Quick Stop Select	10-07	Readout Bus Off Counter
5-42	Off Delay, Relay	6-40	Terminal X30/12 Low Voltage	7-36	Process PID Diff. Gain Limit	8-52	DC Brake Select	10-1*	DeviceNet
5-50	Term. 29 Low Frequency	6-41	Terminal X30/12 High Voltage	7-38	Process PID Feed Forward Factor	8-53	Start Select	10-10	Process Data Type Selection
5-51	Term. 29 High Frequency	6-44	Term. X30/12 Low Ref./Feedb. Value	7-39	On Reference Bandwidth	8-54	Reversing Select	10-11	Process Data Config Write
5-52	Term. 29 Low Ref./Feedb. Value	6-45	Term. X30/12 High Ref./Feedb. Value	7-4*	Adv. Process PID I	8-55	Set-up Select	10-12	Process Data Config Read
5-53	Term. 29 High Ref./Feedb. Value	6-46	Term. X30/12 Filter Time Constant	7-40	Process PID I-part Reset	8-56	Preset Reference Select	10-13	Warning Parameter
5-54	Pulse Filter Time Constant #29	6-50	Terminal 42 Output	7-41	Process PID Output Neg. Clamp	8-57	Profidrive OFF2 Select	10-14	Net Reference
5-55	Term. 33 Low Frequency	6-51	Terminal 42 Output Min Scale	7-42	Process PID Output Pos. Clamp	8-58	Profidrive OFF3 Select	10-15	Net Control
5-56	Term. 33 High Frequency	6-52	Terminal 42 Output Max Scale	7-43	Process PID Gain Scale at Min. Ref.	8-8*	FC Port Diagnostics	10-2*	COS Filters
5-57	Term. 33 Low Ref./Feedb. Value	6-53	Term 42 Output Bus Ctrl	7-44	Process PID Gain Scale at Max. Ref.	8-80	Bus Message Count	10-20	COS Filter 1
5-58	Term. 33 High Ref./Feedb. Value	6-54	Terminal 42 Output Timeout Preset	7-45	Process PID Feed Fwd Resource	8-81	Bus Error Count	10-21	COS Filter 2
5-59	Pulse Filter Time Constant #33	6-55	Analog Output Filter	7-46	Process PID Feed Fwd Normal/ Inv. Ctrl.	8-82	Slave Messages Rcvd	10-22	COS Filter 3
5-6*	Pulse Output	6-6*	Analog Output 2	7-48	PCD Feed Forward	8-9*	Bus Jog Error Count	10-23	COS Filter 4
5-60	Terminal 27 Pulse Output Variable	6-60	Terminal X30/8 Output	7-49	Process PID Output Normal/ Inv. Ctrl.	8-90	Bus Jog 1 Speed	10-3*	Parameter Access
5-62	Pulse Output Max Freq #27	6-61	Terminal X30/8 Min. Scale	7-5*	Adv. Process PID II	8-91	Bus Jog 2 Speed	10-30	Array Index
5-63	Terminal 29 Pulse Output Variable	6-62	Terminal X30/8 Max. Scale	7-50	Process PID Extended PID	9-3*	PROFIBUS	10-31	Store Data Values
5-65	Pulse Output Max Freq #29	6-63	Terminal X30/8 Bus Control	7-51	Process PID Feed Fwd Gain	9-00	Setpoint	10-32	DeviceNet Revision
5-66	Terminal X30/6 Pulse Output Variable	6-64	Terminal X30/8 Output Timeout Preset	7-52	Process PID Feed Fwd Ramp up	9-07	Actual Value	10-33	Store Always
5-68	Pulse Output Max Freq #X30/6	6-7*	Analog Output 3	7-53	Process PID Feed Fwd Ramp down	9-15	PCD Write Configuration	10-34	DeviceNet Product Code
5-7*	24V Encoder Input	6-70	Terminal X45/1 Output	7-56	Process PID Ref. Filter Time	9-16	PCD Read Configuration	10-39	DeviceNet F Parameters
5-70	Term 32/33 Pulses Per Revolution	6-71	Terminal X45/1 Min. Scale	7-57	Process PID Fb. Filter Time	9-18	Node Address	10-5*	CANopen
5-71	Term 32/33 Encoder Direction	6-72	Terminal X45/1 Max. Scale	8-3*	Comm. and Options	9-19	Drive Unit System Number	10-50	Process Data Config Write.
5-8*	I/O Options	6-73	Terminal X45/1 Bus Control	8-0*	General Settings	9-22	Telegram Selection	10-51	Process Data Config Read.
5-80	AHF Cap Reconnect Delay	6-74	Terminal X45/1 Output Timeout Preset	8-01	Control Site	9-23	Parameters for Signals	12-0*	Ethernet
5-9*	Bus Controlled	6-8*	Analog Output 4	8-02	Control Word Source	9-27	Parameter Edit	12-00	IP Settings
5-90	Digital & Relay Bus Control	6-80	Terminal X45/3 Output	8-03	Control Word Timeout Time	9-28	Process Control	12-00	IP Address Assignment
5-93	Pulse Out #27 Bus Control	6-81	Terminal X45/3 Min. Scale	8-04	Control Word Timeout Function	9-44	Fault Message Counter	12-01	IP Address
5-94	Pulse Out #27 Timeout Preset	6-82	Terminal X45/3 Max. Scale	8-05	End-of-Timeout Function	9-45	Fault Code	12-02	Subnet Mask
5-95	Pulse Out #29 Bus Control	6-83	Terminal X45/3 Bus Control	8-06	Reset Control Word Timeout	9-47	Fault Number	12-03	Default Gateway
5-96	Pulse Out #29 Timeout Preset	6-84	Terminal X45/3 Output Timeout Preset	8-07	Diagnosis Trigger	9-52	Fault Situation Counter	12-04	DHCP Server
5-97	Pulse Out #X30/6 Bus Control	7-7*	Controllers	8-08	Readout Filtering	9-53	Fault Warning Word	12-05	Lease Expires
5-98	Pulse Out #X30/6 Timeout Preset	7-0*	Speed PID Ctrl.	8-1*	Ctrl. Word Settings	9-63	Actual Baud Rate	12-06	Name Servers
6-0*	Analog In/Out	7-00	Speed PID Feedback Source	8-10	Control Word Profile	9-64	Device Identification	12-07	Domain Name
6-00	Live Zero Timeout Time	7-01	Speed PID Droop	8-13	Configurable Status Word STW	9-65	Profile Number	12-08	Host Name
6-01	Live Zero Timeout Function	7-02	Speed PID Proportional Gain	8-14	Configurable Control Word CTW	9-67	Control Word 1	12-09	Physical Address
6-1*	Analog Input 1	7-03	Speed PID Integral Time	8-17	Configurable Alarm and Warningword	9-68	Status Word 1	12-1*	Ethernet Link Parameters
6-10	Terminal 53 Low Voltage	7-04	Speed PID Differentiation Time	8-19	Product Code	9-70	Edit Set-up	12-10	Link Status
6-11	Terminal 53 High Voltage	7-05	Speed PID Limit	8-3*	FC Port Settings	9-71	Profibus Save Data Values	12-11	Link Duration
6-12	Terminal 53 Low Current	7-06	Speed PID Lowpass Filter Time	8-30	Protocol	9-72	ProfibusDriveReset	12-12	Auto Negotiation
6-13	Terminal 53 High Current	7-07	Speed PID Feedback Gear Ratio	8-31	Address	9-75	DO Identification	12-13	Link Speed
6-14	Terminal 53 Low Ref./Feedb. Value	7-08	Speed PID Feed Forward Factor	8-32	FC Port Baud Rate	9-80	Defined Parameters (1)	12-14	Link Duplex
6-15	Terminal 53 High Ref./Feedb. Value	7-09	Speed PID Error Correction w/ Ramp	8-33	Parity / Stop Bits	9-81	Defined Parameters (2)	12-2*	Process Data
6-16	Terminal 53 Filter Time Constant	7-1*	Torque PI Ctrl.	8-34	Estimated cycle time	9-82	Defined Parameters (3)	12-20	Control Instance
6-2*	Analog Input 2	7-10	Torque PI Feedback Source	8-35	Minimum Response Delay	9-83	Defined Parameters (4)	12-21	Process Data Config Write
		7-12	Torque PI Proportional Gain	8-36	Max Response Delay	9-84	Defined Parameters (5)	12-22	Process Data Config Read

12-23	Process Data Config Write Size	13-20	SL Controller Timer	14-80	Option Supplied by External 24VDC	15-80	Fan Running Hours	16-61	Terminal 53 Switch Setting
12-24	Process Data Config Read Size	13-4* Logic Rules	Logic Rule Boolean 1	14-88	Option Data Storage	15-81	Preset Fan Running Hours	16-62	Analog Input 53
12-27	Master Address	13-40	Logic Rule Boolean 1	14-89	Option Detection	15-89	Configuration Change Counter	16-63	Terminal 54 Switch Setting
12-28	Store Data Values	13-41	Logic Rule Boolean 2	14-90	Fault Settings	15-9* Parameter Info	Defined Parameters	16-64	Analog Input 54
12-29	Store Alarms	13-42	Logic Rule Boolean 2	15-0* Drive Information	Operating Data	15-92	Analog Output 42 [mA]	16-65	Analog Output [bin]
12-3* EtherNet/IP		13-43	Logic Rule Operator 2	15-00	Operating hours	15-93	Modified Parameters	16-66	Digital Output [bin]
12-30	Warning Parameter	13-44	Logic Rule Boolean 3	15-01	Running Hours	15-98	Drive Identification	16-67	Freq. Input #29 [Hz]
12-31	Net Reference	13-5* States	SL Controller Event	15-02	kWh Counter	15-99	Parameter Metadata	16-68	Freq. Input #33 [Hz]
12-32	Net Control	13-51	SL Controller Action	15-03	Power Up's	16-0*	General Status	16-69	Pulse Output #27 [Hz]
12-33	CLP Revision	14-0* Special Functions	SL Controller Action	15-04	Over Temp's	16-00	Control Word	16-70	Pulse Output #29 [Hz]
12-34	CIP Product Code	14-0* Inverter Switching	Switching Pattern	15-05	Over Volt's	16-01	Reference [Unit]	16-71	Relay Output [bin]
12-35	EDS Parameter	14-00	Switching Frequency	15-06	Reset kWh Counter	16-02	Reference %	16-72	Counter A
12-37	COS Inhibit Timer	14-01	Overmodulation	15-07	Reset Running Hours Counter	16-03	Status Word	16-73	Counter B
12-38	COS Filter	14-03	Dead Time Compensation	15-10	Data Log Settings	16-05	Main Actual Value [%]	16-74	Prec. Stop Counter
12-4* Modbus TCP		14-04	PWM Random	15-11	Logging Interval	16-06	Absolute Position	16-75	Analog In X30/11
12-40	Status Parameter	14-06	Dead Time Compensation	15-12	Trigger Event	16-09	Custom Readout	16-76	Analog In X30/12
12-41	Slave Message Count	14-1* Mains On/Off	Mains Failure	15-13	Fault Log	16-1*	Motor Status	16-77	Analog Out X30/8 [mA]
12-42	Slave Exception Message Count	14-10	Mains Voltage at Mains Fault	15-30	Fault Log: Error Code	16-10	Power [kW]	16-78	Analog Out X45/1 [mA]
12-5* EtherCAT		14-11	Function at Mains Imbalance	15-31	Fault Log: Value	16-11	Power [hp]	16-79	Analog Out X45/3 [mA]
12-50	Configured Station Alias	14-12	Function at Mains Imbalance	15-32	Fault Log: Time	16-12	Motor Voltage	16-8*	Fieldbus & FC Port
12-51	Configured Station Address	14-13	Kin. Backup Trip Recovery Level	15-4	Ordered Typecode String	16-13	Motor Voltage	16-80	Fieldbus CTW 1
12-59	EtherCAT Status	14-14	Kin. Backup Trip Recovery Level	15-45	Actual Typecode String	16-14	Motor current	16-82	Fieldbus REF 1
12-6* Ethernet PowerLink		14-15	Kin. Backup Gain	15-46	Frequency Converter Ordering No	16-15	Frequency [%]	16-84	Comm. Option STW
12-60	Node ID	14-16	Reset Mode	15-47	Power Card Ordering No	16-16	Torque [Nm]	16-85	FC Port CTW 1
12-62	SDO Timeout	14-2* Trip Reset	Automatic Restart Time	15-48	LCP Id No	16-17	Speed [RPM]	16-86	FC Port REF 1
12-63	Basic Ethernet Timeout	14-20	Operation Mode	15-49	SW ID Control Card	16-18	Motor Thermal	16-87	Bus Readout Alarm/Warning
12-66	Threshold	14-21	Typemode Setting	15-51	Frequency Converter Serial Number	16-19	KTY sensor temperature	16-88	Configurable Alarm/Warning Word
12-68	Cumulative Counters	14-22	Trip Delay at Current Limit	15-60	Option Mounted	16-20	Motor Angle	16-9*	Diagnosis Readouts
12-69	Ethernet PowerLink Status	14-23	Trip Delay at Torque Limit	15-61	Option SW Version	16-21	Torque [%] High Res.	16-90	Alarm Word
12-8*	Other Ethernet Services	14-25	Trip Delay at Inverter Fault	15-62	Option Ordering No	16-22	Torque [%]	16-91	Alarm Word 2
12-80	FTP Server	14-26	Production Settings	15-63	Option Serial No	16-23	Motor Shaft Power [kW]	16-92	Warning Word
12-81	HTTP Server	14-28	Service Code	15-71	Slot A Option SW Version	16-24	Calibrated Stator Resistance	16-93	Warning Word 2
12-82	SMTP Service	14-29	Current Limit Ctrl.	15-72	Option in Slot B	16-25	Torque [Nm] High	16-94	Ext. Status Word
12-89	Transparent Socket Channel Port	14-3* Current Limit Ctrl.	Current Lim Ctrl, Proportional Gain	15-73	Option in Slot B	16-3*	Drive Status	17-1*	Inc. Enc. Interface
12-9*	Advanced Ethernet Services	14-30	Current Lim Ctrl, Integration Time	15-74	Option in Slot C0/E0	16-30	DC Link Voltage	17-10	Signal Type
12-90	Cable Diagnostic	14-31	Current Lim Ctrl, Filter Time	15-75	Option in Slot C0/E0	16-32	Brake Energy /s	17-11	Resolution (PPR)
12-91	Auto Cross Over	14-32	Current Lim Ctrl, Filter Time	15-76	Option SW Version	16-33	Brake Energy Average	17-2*	Abs. Enc. Interface
12-92	IGMP Snooping	14-33	Stall Protection	15-77	Option in Slot A	16-34	Heatsink Temp.	17-20	Protocol Selection
12-93	Cable Error Length	14-36	Fieldweakening Function	15-78	Option in Slot B	16-35	Inverter Thermal	17-21	Resolution (Positions/Rev)
12-94	Broadcast Storm Protection	14-4* Energy Optimising	Fieldweakening Function	15-79	Option in Slot B	16-36	Inv. Nom. Current	17-24	SSI Data Length
12-95	Broadcast Storm Filter	14-40	VT Level	15-80	Option in Slot B	16-37	Inv. Max. Current	17-25	Clock Rate
12-96	Port Config	14-41	AEQ Minimum Magnetsation	15-81	Option in Slot B	16-38	SL Controller State	17-26	SSI Data Format
12-98	Interface Counters	14-42	Minimum AEO Frequency	15-82	Option in Slot B	16-39	Control Card Temp.	17-34	HIPERFACE Baudrate
12-99	Media Counters	14-43	Motor Cosphi	15-83	Option in Slot B	16-40	Logging Buffer Full	17-5*	Resolver Interface
13-3* Smart Logic		14-5* Environment	RFI Filter	15-6*	Option Ident	16-41	LCP Bottom Statusline	17-50	Poles
13-0*	SLC Settings	14-50	DC Link Compensation	15-60	Option Mounted	16-45	Motor Phase U Current	17-51	Input Voltage
13-00	SL Controller Mode	14-51	Fan Control	15-61	Option SW Version	16-46	Motor Phase V Current	17-52	Input Frequency
13-01	Start Event	14-52	Fan Monitor	15-62	Option Ordering No	16-47	Motor Phase W Current	17-53	Transformation Ratio
13-02	Stop Event	14-53	Capacitance Output Filter	15-63	Option Serial No	16-48	Speed Ref. After Ramp [RPM]	17-56	Encoder Sim. Resolution
13-03	Reset SLC	14-54	Inductance Output Filter	15-64	Option in Slot A	16-49	Current Fault Source	17-59	Resolver Interface
13-1*	Comparators	14-56	Actual Number of Inverter Units	15-71	Slot A Option SW Version	16-5*	Ref. & Feedsb.	17-6*	Monitoring and App.
13-10	Comparator Operand	14-57	Compatibility	15-72	Option in Slot B	16-50	External Reference	17-60	Feedback Direction
13-11	Comparator Operator	14-59	Legacy Alarm Word	15-73	Option in Slot B	16-51	Pulse Reference	17-61	Feedback Signal Monitoring
13-12	Comparator Value	14-7* Compatibility	Legacy Warning Word	15-74	Option in Slot C0/E0	16-52	Feedback(Unit)	17-7*	Absolute Position
13-1*	RS Flip Flops	14-72	Leg. Ext. Status Word	15-75	Option in Slot C0/E0	16-53	Digi Pot Reference	17-70	Absolute Position Display Unit
13-15	RS-FF Operand S	14-73	Options	15-76	Option in Slot C1/E1	16-57	Feedback [RPM]	17-71	Absolute Position Display Scale
13-16	RS-FF Operand R	14-74	Options	15-77	Option in Slot C1/E1	16-6*	Inputs & Outputs	17-72	Absolute Position Numerator
13-2*	Timers	14-8* Options	Options	15-8*	Operating Data II	16-60	Digital Input	17-73	Absolute Position Denominator

17-74	Absolute Position Offset	32-04	Absolute Encoder Baudrate X55	32-90	Debug Source	33-65	Terminal X59/3 Digital Output	34-61	Axis Status
18-*	Data Readouts 2	32-05	Absolute Encoder Data Length	33-*	MCO Adv. Settings	33-66	Terminal X59/4 Digital Output	34-62	Program Status
18-3*	Analog Readouts	32-06	Absolute Encoder Clock Frequency	33-0*	Home Motion	33-67	Terminal X59/5 Digital Output	34-64	MCO 302 Status
18-36	Temp. Input X48/2 [mA]	32-07	Absolute Encoder Clock Generation	33-01	Force HOME	33-68	Terminal X59/6 Digital Output	34-65	MCO 302 Control
18-37	Temp. Input X48/4	32-08	Absolute Encoder Cable Length	33-00	Zero Point Offset from Home Pos.	33-69	Terminal X59/7 Digital Output	34-7*	Diagnosis readouts
18-38	Temp. Input X48/7	32-09	Encoder Monitoring	33-02	Ramp for Home Motion	33-70	Terminal X59/8 Digital Output	34-70	MCO Alarm Word 1
18-39	Temp. Input X48/10	32-10	Rotational Direction	33-03	Velocity of Home Motion	33-8*	Global Parameters	34-71	MCO Alarm Word 2
18-5*	Active Alarms/Warnings	32-11	User Unit Denominator	33-04	Behaviour during HomeMotion	33-80	Activated Program Number	35-*	Sensor Input Option
18-55	Active Alarm Numbers	32-12	User Unit Numerator	33-1*	Synchronization	33-81	Power-up State	35-0*	Temp. Input Mode
18-56	Active Warning Numbers	32-13	Enc.2 Control	33-10	Sync Factor Master	33-82	Drive Status Monitoring	35-00	Term. X48/4 Temperature Unit
18-6*	Inputs & Outputs 2	32-14	Enc.2 node ID	33-11	Sync Factor Slave	33-83	Behaviour afterError	35-01	Term. X48/4 Input Type
18-60	Digital Input 2	32-15	Enc.2 CAN guard	33-12	Position Offset for Synchronization	33-84	Behaviour afterEsc.	35-02	Term. X48/7 Temperature Unit
18-9*	PID Readouts	32-3*	Encoder 1	33-13	Accuracy Window for Position Sync.	33-85	MCO Supplied by External 24VDC	35-03	Term. X48/7 Input Type
18-90	Process PID Error	32-30	Incremental Signal Type	33-14	Relative Slave Velocity Limit	33-86	Terminal at alarm	35-04	Term. X48/10 Temperature Unit
18-91	Process PID Output	32-31	Incremental Resolution	33-15	Marker Number for Master	33-87	Terminal state at alarm	35-05	Term. X48/10 Input Type
18-92	Process PID Clamped Output	32-32	Absolute Protocol	33-16	Marker Number for Slave	33-88	Master word at alarm	35-06	Temperature Sensor Alarm Function
18-93	Process PID Gain Scaled Output	32-33	Absolute Resolution	33-17	Master Marker Distance	33-9*	MCO Port Settings	35-1*	Temp. Input X48/4
30-*	Special Features	32-35	Absolute Encoder Data Length	33-18	Slave Marker Distance	33-90	X62 MCO CAN node ID	35-14	Term. X48/4 Filter Time Constant
30-0*	Wobbler	32-36	Absolute Encoder Clock Frequency	33-19	Master Marker Type	33-91	X62 MCO CAN baud rate	35-15	Term. X48/4 Temp. Monitor
30-01	Wobble Delta Frequency [Hz]	32-37	Absolute Encoder Clock Generation	33-20	Slave Marker Type	33-94	X60 MCO RS485 serial termination	35-16	Term. X48/4 Low Temp. Limit
30-02	Wobble Delta Frequency [%]	32-38	Absolute Encoder Cable Length	33-21	Master Marker Tolerance Window	33-95	X60 MCO RS485 serial baud rate	35-17	Term. X48/4 High Temp. Limit
30-03	Wobble Delta Freq. Scaling Resource	32-39	Encoder Monitoring	33-22	Slave Marker Tolerance Window	34-*	MCO Data Readouts	35-2*	Temp. Input X48/7
30-04	Wobble Jump Frequency [Hz]	32-40	Encoder Termination	33-23	Start Behaviour for Marker Sync	34-0*	PCD Write Par.	35-24	Term. X48/7 Filter Time Constant
30-05	Wobble Jump Frequency [%]	32-43	Enc.1 Control	33-24	Marker Number for Fault	34-01	PCD 1 Write to MCO	35-25	Term. X48/7 Temp. Monitor
30-06	Wobble Jump Time	32-44	Enc.1 node ID	33-25	Marker Number for Ready	34-02	PCD 2 Write to MCO	35-26	Term. X48/7 Low Temp. Limit
30-07	Wobble Sequence Time	32-45	Enc.1 CAN guard	33-26	Velocity Filter	34-03	PCD 3 Write to MCO	35-27	Term. X48/7 High Temp. Limit
30-08	Wobble Up/ Down Time	32-5*	Feedback Source	33-27	Offset Filter Time	34-04	PCD 4 Write to MCO	35-3*	Temp. Input X48/10
30-09	Wobble Random Function	32-50	Source Slave	33-28	Marker Filter Configuration	34-05	PCD 5 Write to MCO	35-34	Term. X48/10 Filter Time Constant
30-10	Wobble Ratio	32-51	MCO 302 Last Will	33-29	Filter Time for Marker Filter	34-06	PCD 6 Write to MCO	35-35	Term. X48/10 Temp. Monitor
30-11	Wobble Random Ratio Max.	32-52	Source Master	33-30	Maximum Marker Correction	34-07	PCD 7 Write to MCO	35-36	Term. X48/10 Low Temp. Limit
30-12	Wobble Random Ratio Min.	32-6*	PID Controller	33-31	Synchronisation Type	34-08	PCD 8 Write to MCO	35-37	Term. X48/10 High Temp. Limit
30-19	Wobble Delta Freq. Scaled	32-60	Proportional factor	33-32	Feed Forward Velocity Adaptation	34-09	PCD 9 Write to MCO	35-4*	Analog Input X48/2
30-2*	Adv. Start Adjust	32-61	Derivative factor	33-33	Velocity Filter Window	34-10	PCD 10 Write to MCO	35-42	Term. X48/2 Low Current
30-20	High Starting Torque Time [s]	32-62	Integral factor	33-4*	Limit Handling	34-2*	PCD Read Par.	35-43	Term. X48/2 High Current
30-21	High Starting Torque Current [%]	32-63	Limit Value for Integral Sum	33-40	Behaviour atEnd Limit Switch	34-21	PCD 1 Read from MCO	35-44	Term. X48/2 Low Ref./Feedb. Value
30-22	Locked Rotor Protection	32-64	PID Bandwidth	33-41	Negative Software End Limit	34-22	PCD 2 Read from MCO	35-45	Term. X48/2 High Ref./Feedb. Value
30-23	Locked Rotor Detection Time [s]	32-65	Velocity Feed-Forward	33-42	Positive Software End Limit	34-23	PCD 3 Read from MCO	35-46	Term. X48/2 Filter Time Constant
30-24	Locked Rotor Detection Speed Error [%]	32-66	Acceleration Feed-Forward	33-43	Negative Software End Limit Active	34-24	PCD 4 Read from MCO	42-*	Safety Functions
30-8*	Compatibility (I)	32-67	Max. Tolerated Position Error	33-44	Positive Software End Limit Active	34-25	PCD 5 Read from MCO	42-1*	Speed Monitoring
30-80	d-axis Inductance (Ld)	32-68	Reverse Behavior for Slave	33-45	Time in Target Window	34-26	PCD 6 Read from MCO	42-10	Measured Speed Source
30-81	Brake Resistor (ohm)	32-69	Sampling Time for PID Control	33-46	Target Window LimitValue	34-27	PCD 7 Read from MCO	42-11	Encoder Resolution
30-83	Speed PID Proportional Gain	32-70	Scan Time for Profile Generator	33-47	Size of Target Window	34-28	PCD 8 Read from MCO	42-12	Encoder Direction
30-84	Process PID Proportional Gain	32-71	Size of the Control Window (Activation)	33-5*	I/O Configuration	34-29	PCD 9 Read from MCO	42-13	Gear Ratio
31-*	Bypass Option	32-72	Size of the Control Window (Deactiv.)	33-50	Terminal X57/1 Digital Input	34-30	PCD 10 Read from MCO	42-14	Feedback Type
31-00	Bypass Mode	32-73	Integral limit filter time	33-51	Terminal X57/2 Digital Input	34-4*	Inputs & Outputs	42-15	Feedback Filter
31-01	Bypass Start Time Delay	32-74	Position error filter time	33-52	Terminal X57/3 Digital Input	34-40	Digital Inputs	42-17	Tolerance Error
31-02	Bypass Trip Time Delay	32-8*	Velocity & Accel.	33-53	Terminal X57/4 Digital Input	34-41	Digital Outputs	42-18	Zero Speed Timer
31-03	Test Mode Activation	32-80	Maximum Velocity (Encoder)	33-54	Terminal X57/5 Digital Input	34-5*	Process Data	42-19	Zero Speed Limit
31-10	Bypass Status Word	32-81	Shortest Ramp	33-55	Terminal X57/6 Digital Input	34-50	Actual Position	42-2*	Safe Input
31-11	Bypass Running Hours	32-82	Ramp Type	33-56	Terminal X57/7 Digital Input	34-51	Commanded Position	42-20	Safe Function
31-19	Remote Bypass Activation	32-83	Velocity Resolution	33-57	Terminal X57/8 Digital Input	34-52	Actual Master Position	42-21	Type
32-*	MCO Basic Settings	32-84	Default Velocity	33-58	Terminal X57/9 Digital Input	34-53	Slave Index Position	42-22	Discrepancy Time
32-0*	Encoder 2	32-85	Default Acceleration	33-59	Terminal X57/10 Digital Input	34-54	Master Index Position	42-23	Stable Signal Time
32-00	Incremental Signal Type	32-86	Acc. up for limited jerk	33-60	Terminal X59/1 and X59/2 Mode	34-55	Curve Position	42-24	Restart Behaviour
32-01	Incremental Resolution	32-87	Acc. down for limited jerk	33-61	Terminal X59/1 Digital Input	34-56	Track Error	42-3*	General
32-02	Absolute Protocol	32-88	Dec. up for limited jerk	33-62	Terminal X59/2 Digital Input	34-57	Synchronizing Error	42-30	External Failure Reaction
32-03	Absolute Resolution	32-89	Dec. down for limited jerk	33-63	Terminal X59/1 Digital Output	34-58	Actual Velocity	42-31	Reset Source
		32-9*	Development	33-64	Terminal X59/2 Digital Output	34-59	Actual Master Velocity	42-33	Parameter Set Name
								42-35	S-CRC Value

42-36	Level 1 Password	99-22	HS Temp. (PC3)
42-4*	551	99-23	HS Temp. (PC4)
42-40	Type	99-24	HS Temp. (PC5)
42-41	Ramp Profile	99-25	HS Temp. (PC6)
42-42	Delay Time	99-26	HS Temp. (PC7)
42-43	Delta T	99-27	HS Temp. (PC8)
42-44	Deceleration Rate	99-3*	Performance Readouts
42-45	Delta V	99-34	Perf FastThread AOC
42-46	Zero Speed	99-35	Perf SlowThread AOC
42-47	Ramp Time	99-36	Perf IdleThread AOC
42-48	S-ramp Ratio at Decel. Start	99-37	Perf SystemIdleThread AOC
42-49	S-ramp Ratio at Decel. End	99-38	Perf CPU usage AOC (%)
42-5*	SLS	99-39	Performance IntervalCounter
42-50	Cut Off Speed	99-4*	Software Control
42-51	Speed Limit	99-40	StartupWizardState
42-52	Fail Safe Reaction	99-41	Performance Measurements
42-53	Start Ramp	99-5*	PC Debug
42-54	Ramp Down Time	99-50	PC Debug Selection
42-6*	Safe Fieldbus	99-51	PC Debug 0
42-60	Telegram Selection	99-52	PC Debug 1
42-61	Destination Address	99-53	PC Debug 2
42-8*	Status	99-54	PC Debug 3
42-80	Safe Option Status	99-55	PC Debug 4
42-81	Safe Option Status 2	99-56	Fan 1 Feedback
42-82	Safe Control Word	99-57	Fan 2 Feedback
42-83	Safe Status Word	99-58	PC Auxiliary Temp
42-85	Active Safe Func.	99-59	Power Card Temp.
42-86	Safe Option Info	99-8*	RTDC
42-88	Supported Customization File Version	99-80	tCon1 Selection
42-89	Customization File Version	99-81	tCon2 Selection
42-9*	Special	99-82	Trig Compare Selection
42-90	Restart Safe Option	99-83	Trig Compare Operator
99-*	Devel support	99-84	Trig Compare Operand
99-0*	DSP Debug	99-85	Trig Start
99-00	DAC 1 selection	99-86	Pre-trigger
99-01	DAC 2 selection	99-9*	Internal Values
99-02	DAC 3 selection	99-90	Options present
99-03	DAC 4 selection	99-91	Motor Power Internal
99-04	DAC 1 scale	99-92	Motor Voltage Internal
99-05	DAC 2 scale	99-93	Motor Frequency Internal
99-06	DAC 3 scale	600-*	PROFIsafe
99-07	DAC 4 scale	600-22	PROFIdrive/safe Tel. Selected
99-08	Test param 1	600-44	Fault Message Counter
99-09	Test param 2	600-47	Fault Number
99-10	DAC Option Slot	600-52	Fault Situation Counter
99-1*	Hardware Control	601-*	PROFIdrive 2
99-11	RF1 2	601-22	PROFIdrive Safety Channel Tel. No.
99-12	Fan		
99-1*	Software Readouts		
99-13	Idle time		
99-14	Paramdb requests in queue		
99-15	Secondary Timer at Inverter Fault		
99-16	No of Current Sensors		
99-17	tCon1 time		
99-18	tCon2 time		
99-19	Time Optimize Measure		
99-2*	Heatsink Readouts		
99-20	HS Temp. (PC1)		
99-21	HS Temp. (PC2)		

9.3 Active Filter Parameter Lists

9.3.1 Default Settings

Changes during operation:

True means that the parameter can be changed while the active filter is in operation, and *False* means that the unit must be stopped before a change can be made.

4-Set-up:

All set-up: The parameter can be set individually in each of the 4 set-ups, (1 single parameter can have 4 different data values).

1 set-up: Data value is the same in all set-ups.

SR:

Size-related.

N/A:

No default value available.

Conversion index:

This number refers to a conversion figure used when writing or reading with an active filter.

Conv. index	100	75	74	70	67	6	5	4	3	2	1	0	-1	-2	-3	-4	-5	-6
Conv. factor	1	3600000	3600	60	1/60	1000000	100000	10000	1000	100	10	1	0.1	0.01	0.001	0.0001	0.00001	0.000001

Table 9.1 Conversion Index

Data type	Description	Type
2	Integer 8	Int8
3	Integer 16	Int16
4	Integer 32	Int32
5	Unsigned 8	UInt8
6	Unsigned 16	UInt16
7	Unsigned 32	UInt32
9	Visible string	VisStr
33	Normalised value 2 bytes	N2
35	Bit sequence of 16 boolean variables	V2
54	Time difference without date	TimD

Table 9.2 Data Type and Description

9.3.2 0-** Operation/Display

Par. No. #	Parameter description	Default value	4-set-up	Change during operation	Conversion index	Type
0-0* Basic Settings						
0-01	Language	[0] English	1 set-up	TRUE	-	Uint8
0-04	Operating state at power-up (hand)	[1] Forced stop	All set-ups	TRUE	-	Uint8
0-1* Set-up Operations						
0-10	Active set-up	[1] Set-up 1	1 set-up	TRUE	-	Uint8
0-11	Edit set-up	[1] Set-up 1	All set-ups	TRUE	-	Uint8
0-12	This set-up linked to	[0] Not linked	All set-ups	FALSE	-	Uint8
0-13	Readout: Linked set-ups	0 N/A	All set-ups	FALSE	0	Uint16
0-14	Readout: Edit set-ups/channel	0 N/A	All set-ups	TRUE	0	Int32
0-2* LCP Display						
0-20	Display Line 1.1 small	30112	All set-ups	TRUE	-	Uint16
0-21	Display Line 1.2 small	30110	All set-ups	TRUE	-	Uint16
0-22	Display Line 1.3 small	30120	All set-ups	TRUE	-	Uint16
0-23	Display Line 2 large	30100	All set-ups	TRUE	-	Uint16
0-24	Display Line 3 large	30121	All set-ups	TRUE	-	Uint16
0-25	My personal menu	ExpressionLimit	1 set-up	TRUE	0	Uint16
0-4* LCP Keypad						
0-40	[Hand on] key on LCP	[1] Enabled	All set-ups	TRUE	-	Uint8
0-41	[Off] key on LCP	[1] Enabled	All set-ups	TRUE	-	Uint8
0-42	[Auto on] key on LCP	[1] Enabled	All set-ups	TRUE	-	Uint8
0-43	[Reset] key on LCP	[1] Enabled	All set-ups	TRUE	-	Uint8
0-5* Copy/Save						
0-50	LCP copy	[0] No copy	All set-ups	FALSE	-	Uint8
0-51	Set-up copy	[0] No copy	All set-ups	FALSE	-	Uint8
0-6* Password						
0-60	Main menu password	100 N/A	1 set-up	TRUE	0	Int16
0-61	Access to main menu without password	[0] Full access	1 set-up	TRUE	-	Uint8
0-65	Quick menu password	200 N/A	1 set-up	TRUE	0	Int16
0-66	Access to quick menu without password	[0] Full access	1 set-up	TRUE	-	Uint8

9.3.3 5-** Digital In/Out

Par. No. #	Parameter description	Default value	4-set-up	Change during operation	Conversion index	Type
5-0* Digital I/O mode						
5-00	Digital I/O mode	[0] PNP	All set-ups	FALSE	-	Uint8
5-01	Terminal 27 mode	[0] Input	All set-ups	TRUE	-	Uint8
5-02	Terminal 29 mode	[0] Input	All set-ups	TRUE	-	Uint8
5-1* Digital Inputs						
5-10	Terminal 18 digital input	[8] Start	All set-ups	TRUE	-	Uint8
5-11	Terminal 19 digital input	[0] No operation	All set-ups	TRUE	-	Uint8
5-12	Terminal 27 digital input	[0] No operation	All set-ups	TRUE	-	Uint8
5-13	Terminal 29 digital input	[0] No operation	All set-ups	TRUE	-	Uint8
5-16	Terminal X30/2 digital input	[0] No operation	All set-ups	TRUE	-	Uint8
5-17	Terminal X30/3 digital input	[0] No operation	All set-ups	TRUE	-	Uint8
5-18	Terminal X30/4 digital input	[0] No operation	All set-ups	TRUE	-	Uint8
5-19	Terminal 37 Safe stop	[1] Safe Stop Alarm	1 set-up	TRUE	-	Uint8
5-3* Digital Outputs						
5-30	Terminal 27 Digital output	[0] No operation	All set-ups	TRUE	-	Uint8
5-31	Terminal 29 Digital output	[0] No operation	All set-ups	TRUE	-	Uint8
5-4* Relays						
5-40	Function relay	[0] No operation	All set-ups	TRUE	-	Uint8
5-41	On delay, relay	0.30 s	All set-ups	TRUE	-2	Uint16
5-42	Off delay, relay	0.30 s	All set-ups	TRUE	-2	Uint16

9

9.3.4 8-** Comm. and Options

Par. No. #	Parameter description	Default value	4-set-up	Change during operation	Conversion index	Type
8-0* General Settings						
8-01	Control site	[0] Digital and ctrl.word	All set-ups	TRUE	-	Uint8
8-02	Control word source	null	All set-ups	TRUE	-	Uint8
8-03	Control word timeout time	1.0 s	1 set-up	TRUE	-1	Uint32
8-04	Control word timeout function	[0] Off	1 set-up	TRUE	-	Uint8
8-05	End-of-timeout Function	[1] Resume set-up	1 set-up	TRUE	-	Uint8
8-06	Reset control word timeout	[0] Do not reset	All set-ups	TRUE	-	Uint8
8-3* FC Port Settings						
8-30	Protocol	[1] FC MC	1 set-up	TRUE	-	Uint8
8-31	Address	2 N/A	1 set-up	TRUE	0	Uint8
8-32	FC port baud rate	[2] 9600 Baud	1 set-up	TRUE	-	Uint8
8-35	Minimum response delay	10 ms	All set-ups	TRUE	-3	Uint16
8-36	Max response delay	5000 ms	1 set-up	TRUE	-3	Uint16
8-37	Max liter-char delay	25 ms	1 set-up	TRUE	-3	Uint16
8-5* Digital/Bus						
8-53	Start select	[3] Logic OR	All set-ups	TRUE	-	Uint8
8-55	Set-up select	[3] Logic OR	All set-ups	TRUE	-	Uint8

9.3.5 14-** Special Functions

Par. No. #	Parameter description	Default value	4-set-up	Change during operation	Conversion index	Type
14-2* Trip Reset						
14-20	Reset mode	[0] Manual reset	All set-ups	TRUE	-	UInt8
14-21	Automatic restart time	10 s	All set-ups	TRUE	0	UInt16
14-22	Operation mode	[0] Normal operation	All set-ups	TRUE	-	UInt8
14-23	Typecode setting	null	2 set-ups	FALSE	-	UInt8
14-28	Production settings	[0] No action	All set-ups	TRUE	-	UInt8
14-29	Service code	0 N/A	All set-ups	TRUE	0	Int32
14-5* Environment						
14-50	RFI filter	[1] On	1 set-up	FALSE	-	UInt8
14-53	Fan monitor	[1] Warning	All set-ups	TRUE	-	UInt8
14-54	Bus partner	1 N/A	2 set-ups	TRUE	0	UInt16

9.3.6 15-** FC Information

Par. No. #	Parameter description	Default value	4-set-up	Change during operation	Conversion index	Type
15-0* Operating Data						
15-00	Operating hours	0 h	All set-ups	FALSE	74	UInt32
15-01	Running hours	0 h	All set-ups	FALSE	74	UInt32
15-03	Power up's	0 N/A	All set-ups	FALSE	0	UInt32
15-04	Over temp's	0 N/A	All set-ups	FALSE	0	UInt16
15-05	Over volt's	0 N/A	All set-ups	FALSE	0	UInt16
15-07	Reset running hours counter	[0] Do not reset	All set-ups	TRUE	-	UInt8
15-1* Data Log Settings						
15-10	Logging source	0	2 set-ups	TRUE	-	UInt16
15-11	Logging interval	ExpressionLimit	2 set-ups	TRUE	-3	TimD
15-12	Trigger event	[0] False	1 set-up	TRUE	-	UInt8
15-13	Logging mode	[0] Log always	2 set-ups	TRUE	-	UInt8
15-14	Samples before trigger	50 N/A	2 set-ups	TRUE	0	UInt8
15-2* Historic Log						
15-20	Historic log: Event	0 N/A	All set-ups	FALSE	0	UInt8
15-21	Historic log: Value	0 N/A	All set-ups	FALSE	0	UInt32
15-22	Historic log: Time	0 ms	All set-ups	FALSE	-3	UInt32
15-3* Fault Log						
15-30	Fault log: Error code	0 N/A	All set-ups	FALSE	0	UInt16
15-31	Fault log: Value	0 N/A	All set-ups	FALSE	0	Int16
15-32	Fault log: Time	0 s	All set-ups	FALSE	0	UInt32
15-4* Unit Identification						
15-40	FC type	0 N/A	All set-ups	FALSE	0	VisStr[6]
15-41	Power section	0 N/A	All set-ups	FALSE	0	VisStr[20]
15-42	Voltage	0 N/A	All set-ups	FALSE	0	VisStr[20]
15-43	Software version	0 N/A	All set-ups	FALSE	0	VisStr[5]
15-44	Ordered typecode string	0 N/A	All set-ups	FALSE	0	VisStr[40]
15-45	Actual typecode string	0 N/A	All set-ups	FALSE	0	VisStr[40]
15-46	Unit ordering number	0 N/A	All set-ups	FALSE	0	VisStr[8]
15-47	Power card ordering number	0 N/A	All set-ups	FALSE	0	VisStr[8]
15-48	LCP ID number	0 N/A	All set-ups	FALSE	0	VisStr[20]
15-49	SW ID control card	0 N/A	All set-ups	FALSE	0	VisStr[20]

Par. No. #	Parameter description	Default value	4-set-up	Change during operation	Conversion index	Type
15-50	SW ID power card	0 N/A	All set-ups	FALSE	0	VisStr[20]
15-51	Unit serial number	0 N/A	All set-ups	FALSE	0	VisStr[10]
15-53	Power card serial number	0 N/A	All set-ups	FALSE	0	VisStr[19]
15-6* Option Ident						
15-60	Option mounted	0 N/A	All set-ups	FALSE	0	VisStr[30]
15-61	Option SW version	0 N/A	All set-ups	FALSE	0	VisStr[20]
15-62	Option ordering number	0 N/A	All set-ups	FALSE	0	VisStr[8]
15-63	Option serial number	0 N/A	All set-ups	FALSE	0	VisStr[18]
15-70	Option in slot A	0 N/A	All set-ups	FALSE	0	VisStr[30]
15-71	Slot A option SW version	0 N/A	All set-ups	FALSE	0	VisStr[20]
15-72	Option in slot B	0 N/A	All set-ups	FALSE	0	VisStr[30]
15-73	Slot B option SW version	0 N/A	All set-ups	FALSE	0	VisStr[20]
15-74	Option in slot C0	0 N/A	All set-ups	FALSE	0	VisStr[30]
15-75	Slot C0 option SW version	0 N/A	All set-ups	FALSE	0	VisStr[20]
15-76	Option in slot C1	0 N/A	All set-ups	FALSE	0	VisStr[30]
15-77	Slot C1 option SW version	0 N/A	All set-ups	FALSE	0	VisStr[20]
15-9* Parameter Info						
15-92	Defined parameters	0 N/A	All set-ups	FALSE	0	Uint16
15-93	Modified parameters	0 N/A	All set-ups	FALSE	0	Uint16
15-98	Unit identification	0 N/A	All set-ups	FALSE	0	VisStr[40]
15-99	Parameter metadata	0 N/A	All set-ups	FALSE	0	Uint16

9.3.7 16-** Data Readouts

Par. No. #	Parameter description	Default value	4-set-up	Change during operation	Conversion index	Type
16-0* General Status						
16-00	Control word	0 N/A	All set-ups	FALSE	0	V2
16-03	Status word	0 N/A	All set-ups	FALSE	0	V2
16-3* AF Status						
16-30	DC link voltage	0 V	All set-ups	FALSE	0	Uint16
16-34	Heatsink temp.	0 °C	All set-ups	FALSE	100	Uint8
16-35	Inverter thermal	0 %	All set-ups	FALSE	0	Uint8
16-36	Inv. nom. current	ExpressionLimit	All set-ups	FALSE	-2	Uint32
16-37	Inv. max. current	ExpressionLimit	All set-ups	FALSE	-2	Uint32
16-39	Control card temp.	0 °C	All set-ups	FALSE	100	Uint8
16-40	Logging buffer full	[0] No	All set-ups	TRUE	-	Uint8
16-49	Current fault source	0 N/A	All set-ups	TRUE	0	Uint8
16-6* Inputs & Outputs						
16-60	Digital input	0 N/A	All set-ups	FALSE	0	Uint16
16-66	Digital output [bin]	0 N/A	All set-ups	FALSE	0	Int16
16-71	Relay output [bin]	0 N/A	All set-ups	FALSE	0	Int16
16-8* Fieldbus & FC Port						
16-80	Fieldbus CTW 1	0 N/A	All set-ups	FALSE	0	V2
16-84	Comm. option STW	0 N/A	All set-ups	FALSE	0	V2
16-85	FC port CTW 1	0 N/A	All set-ups	FALSE	0	V2
16-9* Diagnosis Readouts						
16-90	Alarm word	0 N/A	All set-ups	FALSE	0	Uint32
16-91	Alarm word 2	0 N/A	All set-ups	FALSE	0	Uint32
16-92	Warning word	0 N/A	All set-ups	FALSE	0	Uint32
16-93	Warning word 2	0 N/A	All set-ups	FALSE	0	Uint32
16-94	Ext. status word	0 N/A	All set-ups	FALSE	0	Uint32

9.3.8 300-** AF Settings

NOTICE

Except for parameter 300-10 Active Filter Nominal Voltage, it is not recommended to change the settings in this parameter group.

Par. No. #	Parameter description	Default value	4-set-up	Change during operation	Conversion index	Type
300-0* General Settings						
300-00	Harmonic cancellation mode	[0] Overall	All set-ups	TRUE	-	Uint8
300-01	Compensation priority	[0] Harmonics	All set-ups	TRUE	-	Uint8
300-08	Lagging reactive current	[0] Disabled	All set-ups			
300-1* Network Settings						
300-10	Active filter nominal voltage	ExpressionLimit	2 set-ups	FALSE	0	Uint32
300-2* CT Settings						
300-20	CT primary rating	ExpressionLimit	2 set-ups	FALSE	0	Uint32
300-22	CT nominal voltage	342 V	2 set-ups	FALSE	0	Uint32
300-24	CT sequence	[0] L1, L2, L3	2 set-ups	FALSE	-	Uint8
300-25	CT polarity	[0] Normal	2 set-ups	FALSE	-	Uint8
300-26	CT placement	[1] Load Current	2 set-ups	FALSE	-	Uint8
300-29	Start auto CT detection	[0] Off	All set-ups	FALSE	-	Uint8
300-3* Compensation						
300-30	Compensation points	0.0 A	All set-ups	TRUE	-1	Uint32
300-35	Cosphi reference	0.500 N/A	All set-ups	TRUE	-3	Uint16
300-4* Paralleling						
300-40	Master follower selection	[2] Not Paralleled	2 set-ups	FALSE	-	Uint8
300-41	Follower ID	1 N/A	2 set-ups	FALSE	0	Uint32
300-42	Number of follower AFs	1 N/A	2 set-ups	FALSE	0	Uint32
300-5* Sleep Mode						
300-50	Enable sleep mode	null	2 set-ups	TRUE	-	Uint8
300-51	Sleep mode trig source	[0] Mains current	All set-ups	TRUE	-	Uint8
300-52	Sleep mode wake up trigger	ExpressionLimit	All set-ups	TRUE	0	Uint32
300-53	Sleep mode sleep trigger	80 %	All set-ups	TRUE	0	Uint32

9.3.9 301-** AF Readouts

Par. No. #	Parameter description	Default value	4-set-up	Change during operation	Conversion index	Type
301-0* Output Currents						
301-00	Output current [A]	0.00 A	All set-ups	TRUE	-2	Int32
301-01	Output current [%]	0.0 %	All set-ups	TRUE	-1	Int32
301-1* Unit Performance						
301-10	THD of current [%]	0.0 %	All set-ups	TRUE	-1	Uint16
301-11	Estimated THD of voltage [%]	0.0 %	All set-ups			Uint16
301-12	Power factor	0.00 N/A	All set-ups	TRUE	-2	Uint16
301-13	Cosphi	0.00 N/A	All set-ups	TRUE	-2	Int16
301-14	Leftover currents	0.0 A	All set-ups	TRUE	-1	Uint32
301-2* Mains Status						
301-20	Mains current [A]	0 A	All set-ups	TRUE	0	Int32
301-21	Mains frequency	0 Hz	All set-ups	TRUE	0	Uint8
301-22	Fund. mains current [A]	0 A	All set-ups	TRUE	0	Int32

10 Appendix B

10.1 Abbreviations and Conventions

AC	Alternating current
AEO	Automatic energy optimisation
AMA	Automatic motor adaptation
AWG	American wire gauge
°C	Degrees celsius
DC	Direct current
EMC	Electromagnetic compatibility
ETR	Electronic thermal relay
$f_{M,N}$	Nominal motor frequency
FC	Frequency converter
I_{LIM}	Current limit
I_{INV}	Rated inverter output current
$I_{M,N}$	Nominal motor current
$I_{VLT,MAX}$	The maximum output current
$I_{VLT,N}$	The rated output current supplied by the frequency converter
IP	Ingress protection
LCP	Local control panel
N.A.	Not applicable
$P_{M,N}$	Nominal motor power
PCB	Printed circuit board
PE	Protective earth
PELV	Protective extra low voltage
Regen	Regenerative terminals
RPM	Revolutions per minute
T_{LIM}	Torque limit
$U_{M,N}$	Nominal motor voltage

Table 10.1 Abbreviations

Conventions

Numbered lists indicate procedures.

Bullet lists indicate other information and description of illustrations.

Italicised text indicates:

- Cross-reference.
- Link.
- Footnote.
- Parameter name, parameter group name, parameter option.

Index

A

A53 switch.....	51
A54 switch.....	51
Abbreviation.....	115
AC mains.....	20
Active filter.....	5
Additional resources.....	5
ADN compliance.....	15
AF Readouts.....	114
AF Settings.....	114
Airflow.....	23
Alarm log.....	57
AMA.....	51, 69, 73
AMA with T27 connected.....	63
AMA without T27 connected.....	63
AMA, successful.....	52
AMA, unsuccessful.....	52
Analog output.....	94
Analog signal.....	69
Analog speed reference.....	64
Anchoring.....	26
Application examples.....	63
Approval.....	15
Auto on.....	57, 62
Auto remote coasting.....	56
Automatic energy optimisation.....	61
Automatic motor adaptation.....	62
Automatic Motor Adaptation (AMA).....	51
Auto-reset.....	56

B

Back cooling.....	23
Bottom view.....	26
Brake	
control.....	70
resistor.....	69
Braking.....	71
Branch circuit protection.....	98
Break	
Brake cable.....	40
Brake chopper.....	40
Bus termination switch.....	51

C

Cable	
Cabling.....	38
Motor cable.....	36
Screened cable.....	39, 54
Cable length, cross-section.....	93
CE compliance mark.....	15
Circuit breaker.....	55
Closed loop.....	50
Comm. and Options.....	110
Communication option.....	72
Compliance mark, CE.....	15
Conduit.....	54
Control	
card.....	69
card performance.....	96
card, 24 V DC output.....	95
card, RS485 serial communication.....	94
characteristic.....	96
system.....	5
terminal.....	57, 59
terminals, access.....	45
wiring.....	38, 54
Control card, USB serial communication.....	96
Control terminal.....	45
Convention.....	115
Cooling.....	23
Cooling clearance.....	54
Current	
Current.....	15
distortion.....	16
rating.....	21, 69
DC current.....	36
Full load current.....	21
Fundamental current.....	15
Harmonic current.....	15
Input.....	15
Output current.....	21, 69

D

Data Readouts.....	113
DC link.....	69, 80
Default settings.....	58, 108
Definition.....	5
Delta.....	51
Derating, altitude.....	98
Digital In/Out.....	110
Digital input.....	70, 93
Digital output.....	95
Dimension.....	15
Discharge time.....	20

Disconnect switch.....	54, 56	Harmonics	
Distortion.....	6	Analysis.....	15
E		Harmonics.....	15, 16, 17
ELCB relay.....	39	distortion.....	15
Electrical installation.....	45	Overload prevention.....	15
Electrical noise.....	38	Voltage harmonics.....	16
Electromechanical brake.....	49	Heat sink.....	73
EMC.....	54	Heater.....	52
EMC-compliant installation.....	37	High voltage.....	54
Enclosure.....	15	I	
Exploded view.....	7	IEC emergency stop, Pilz safety relay.....	53
External alarm reset.....	65	Initialisation.....	58
External fan supply.....	41	Input power.....	20, 54, 68, 82
F		Input signal.....	50
Factory installed brake chopper option.....	40	Input voltage.....	56, 68
Fan.....	41	Inputs	
Fault log.....	57	Analog input.....	69
Fault message, active filter.....	80	Analog inputs.....	94
FC Information.....	111	Input power.....	38, 54
Feedback.....	50, 54, 73	Input terminal.....	50, 54, 69
F-frame option.....	52	Installation.....	54, 56
Fieldbus connection.....	43	Insulation resistance monitor.....	53
Filter capacitor.....	39	Intermediate circuit.....	69
Final set-up and test.....	51	IT main.....	39
Fourier series analysis.....	15	Items supplied.....	22
Fuse.....	36, 54, 72, 82, 98	L	
Fuse tables.....	99	Latched start/stop inverse.....	65
Fusing.....	38, 54	Leakage current (>3.5 mA).....	39
G		Lifting.....	24
Grid condition.....	97	Local control.....	57
Ground connection.....	38, 54	Local control panel (LCP).....	56
Ground wire.....	38, 54	M	
Grounding.....	38, 39, 54	Main menu.....	57
Grounding hazard.....	38	Mains	
H		connection.....	41
Hand on.....	57	input.....	33
Harmonic mitigation performance.....	97	supply (L1, L2, L3).....	93
Harmonics.....	6	terminal.....	50
		voltage.....	56
		Supply.....	15
		Manual initialisation.....	58
		Manual motor starter.....	53
		MCT 10.....	56
		Mechanical brake control.....	49, 67
		Mechanical dimension.....	90
		Menu key.....	56, 57
		Menu structure.....	57

Motor	
cable.....	39
current.....	56, 62, 73
data.....	60, 62, 69, 74
insulation.....	40
name plate.....	51
output.....	93
power.....	56, 73
protection.....	96
rotation.....	62
rotation check.....	40
speed.....	59
thermal protection.....	50
thermistor.....	66
wiring.....	54
Mounting.....	54
Multiple frequency converters.....	36
N	
Nameplate.....	22
NAMUR.....	52
Navigation key.....	56, 57, 59
NDE bearing.....	41
Noise isolation.....	54
Non-UL compliance.....	99
O	
Open loop.....	50
Operation key.....	56
Operation/Display.....	109
Optional equipment.....	5, 56
Output performance (U, V, W).....	93
Overcurrent protection.....	36
Overload protection.....	21
P	
Parallel connection, motor.....	50
Parameter menu structure.....	103
PELV.....	63
Phase loss.....	69
Planning, installation site.....	21
Point of common coupling.....	16
Potentiometer.....	65
Power.....	38
Power connection.....	36, 38
Power factor.....	54
Power ranges.....	97
Power rating.....	15
Power, input.....	68
Preset speeds.....	65
Programming.....	56, 57, 69
Protection, feature.....	96
Pulse input.....	94
Pulse start/stop.....	64
Q	
Qualified personnel.....	20
Quick menu.....	56, 57
R	
RCD.....	39
Reactive current compensation.....	97
Reference	
Reference.....	56, 63
Relay output.....	95
Reset.....	56, 57, 58, 68, 69, 70, 74, 75
Residual current device.....	52
Reversing.....	65
RFI capacitor.....	39
RFI switch.....	39
RS485.....	49, 66
Run command.....	62
S	
Safe Torque Off.....	49, 64
Screened/armoured cable.....	42
Screening, cable.....	38
Serial communication.....	57, 68, 96
Set-up.....	57, 62
Shipping damage.....	21
Short circuit	
Short-circuit ratio.....	16
Short circuit.....	70
SmartStart.....	59
Special Functions.....	111
Speed reference.....	50, 62, 64, 65
Start/stop command.....	64
Start-up.....	58, 82
Status display.....	68
Status mode.....	68
STO.....	49
Supply voltage.....	54, 72
Surrounding.....	96
Switch.....	50
Switching frequency.....	38

T

Temperature limit.....	54
Terminal function.....	41
Terminal location.....	30
Terminals	
Input terminal.....	69
Output terminal.....	54
Terminal 53.....	50
Terminal 54.....	50
Thermal motor protection.....	70
Thermistor.....	63, 70
Torque.....	35, 70
Torque characteristic.....	93
Torque, terminals.....	35
Total harmonic distortion.....	15
Transformers.....	15
Trip.....	66

U

Undervoltage.....	17
-------------------	----

V

Voltage imbalance.....	69
Voltage level.....	93
Voltage, input.....	68
VVC+.....	61

W

Wire size.....	36
Wiring.....	15
Working principle.....	6



.....
Danfoss can accept no responsibility for possible errors in catalogues, brochures and other printed material. Danfoss reserves the right to alter its products without notice. This also applies to products already on order provided that such alterations can be made without subsequential changes being necessary in specifications already agreed. All trademarks in this material are property of the respective companies. Danfoss and the Danfoss logotype are trademarks of Danfoss A/S. All rights reserved.
.....

Danfoss A/S
Ulsnaes 1
DK-6300 Graasten
vlt-drives.danfoss.com

