

GRLM-70

Dinel®

RADAR LEVEL METER „MIRANDA“

Suited to continuous level measurement of various liquids, mashes, bulk solids and powders.



HART
COMMUNICATION PROTOCOL



- Radar level meter with guided wave (TDR).
- Immediate view of the measured values on OLED or LCD display units.
- Universal use, direct mounting into containers, silos, vessels, reservoirs, etc.
- Variants with rod or rope electrode.
- Measuring range up to 40 m.
- Xi, XiT versions for usage in explosive areas, or Xt, XtT versions for usage in flammable dusts areas.
- Current output (4 ... 20 mA) with HART® protocol or output RS-485 Modbus.
- Stainless steel design suitable for the food and pharmaceutical industries.

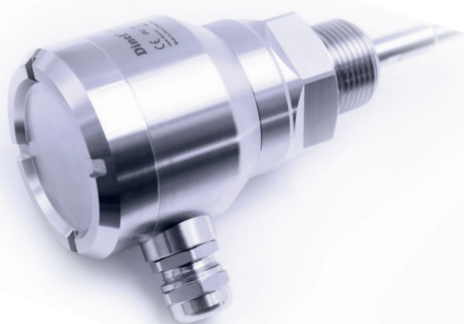

Technical specifications

Supply voltage	GRLM-70N(T)-__	18 ... 36 V DC
	GRLM-70Xi(T)-__	18 ... 30 V DC
	GRLM-70Xt(T)-__	18 ... 33 V DC
Output type	GRLM-70_--_-I	4 ... 20 mA with HART®
	GRLM-70_--_-M	RS-485 / Modbus RTU
Current consumption	GRLM-70_--_-I	4 ... 20 mA / max. 22 mA
	GRLM-70_--_-M	type 10 mA / max. 30 mA
Basic measurement accuracy (for reference reflecting surface)		± 2 mm
Error of current output ²⁾		max. 80 µA
Resolution		0,1 mm
Maximal length of measuring electrode	GRLM-70_-10, 13	8 m
	GRLM-70_-11 (12)	2 m
	GRLM-70_-20	3 m
	GRLM-70_-30 (33,34,35)	40 m
	GRLM-70_-32	15 m
Dead zone ³⁾		see instruction manual
Adjustable measuring range (SPAN)		min. 200 mm
Electrical parameters for variants Xi (XiT) - max. internal values		U _i =30 V DC; I _i =132 mA; P _i =0,99W; C=370 nF; L=0,9 mH
Measurement sensitivity (8 degrees)		low (1) - medium (3) - high (5) - user (1 - 8)
Failure indication (echo loss) adjustable in modes		3,75 mA, 4 mA, 20 mA, 22 mA, LAST ⁴⁾
Damping		1 ... 99 s
Rise time		approx. 60 s
Leakage resistance electrode - housing		10 kΩ
Coupling capacity (housing - power) / dielectric strength		5 nF/500 V AC
Maximal resistance of current output load R _{max} for voltage - 24V DC / 22V DC / 20V DC		270 Ω/180 Ω/90 Ω ⁵⁾
Maximum tensile strength of the rope electrode		1400 kg ⁶⁾
Ambient temperature range ⁷⁾		-30 ... +70 °C
Process temperature range ⁷⁾		-40 ... +200 °C
Media temperature range ⁷⁾		-40 ... +300 °C
Process pressure (for temperature +85 °C)	GRLM-70N-10 (00, 20, 30, 33, 34, 35, 36, 37)	0 ... 100 bar
	GRLM-70N-11 (12, 13)	0 ... 20 bar
	GRLM-70N-32	0 ... 5 bar
Protection class		IP67

1) Metal circular plate 0,5 m², type with reference tube GRLM-70_-20 water.

2) This error only applies to the current output version. Data outputs (HART, MODBUS) are not affected by this error.

3) Dead zone = blind zone = blocking distance at the beginning and end of the electrode.

4) During an echo failure, the display shows the last measured value and the current is held at the last valid value.

5) Including 250Ω resistor when connected with HART.

6) All ropes except the rope of GRLM-70_-32 type.

7) See instruction manual.

BASIC FEATURES AND VARIANTS

The GRLM® radar level meters are compact measuring devices consisting of two main parts – a level meter (housing) and a display module (display). The electronics transmits very short electrical pulses (0.5 ns), which are linked to a one-wire transmission line (measuring electrode). Measuring electrode can be created of rod or rope. The pulse propagates along the electrode in the form of electromagnetic wave toward the level surface, where it is partly reflected and the reflected component is returned to the receiving module of the electronics. The electronics measures the time of flight of electromagnetic wave and the instant distance to the surface level is calculated. Then based on the height of the level, the level meter current output 4 ... 20 mA is set with the HART communications or an industrial RS-485 line with Modbus RTU communications and the measured value is shown on the display.

Radar level meters with guided wave are suited to continuous level measurement of various liquid, mush and bulk-solid materials. Level meters are resistant against changes in the atmosphere (pressure, temperature, dust, steam) and to changes in medium parameters (change in dielectric constant, conductivity)

VARIANTS

code	type of electrode	length of electrode
GRLM-70_-00	Without electrode	-
GRLM-70_-10	Uncoated stainless steel rod electrode	0,5 ... 8 m
GRLM-70_-11	Fully coated stainless steel rod electrode (PFA)	0,5 ... 2 m
GRLM-70_-12	Fully coated stainless steel rod electrode (FEP)	0,5 ... 2 m
GRLM-70_-13	Semi-coated stainless steel rod electrode (FEP)	0,5 ... 8 m
GRLM-70_-20	Uncoated stainless steel rod electrode with reference tube	0,5 ... 3 m
GRLM-70_-30	Uncoated stainless steel rope electrode and weight	1 ... 40 m
GRLM-70_-32	Fully coated stainless steel rope electrode (FEP) and coated weight (FEP),	1 ... 15 m
GRLM-70_-33	Uncoated stainless steel rope electrode with anchorage	1 ... 40 m
GRLM-70_-34	Coated stainless steel rope electrode (Polyamide) and uncoated weight	1 ... 40 m
GRLM-70_-35	Coated stainless steel rope electrode (Polyamide) with uncoated anchorage	1 ... 40 m
GRLM-70_-36	Non-insulated rope electrode without weights	1 ... 40 m
GRLM-70_-37	Insulated rope electrode without weights (polyamide rope insulation)	1 ... 40 m

DIMENSIONS

GRLM-70_-00

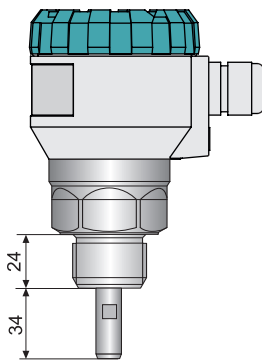

GRLM-70_-10

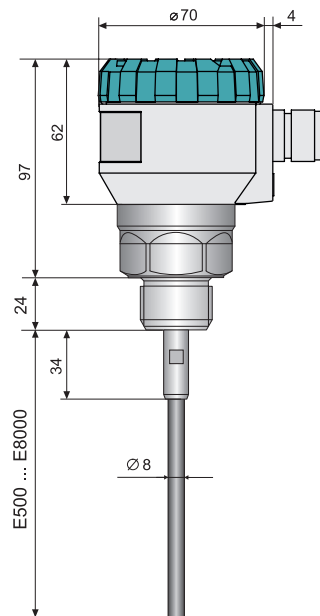

GRLM-70_-11(12)

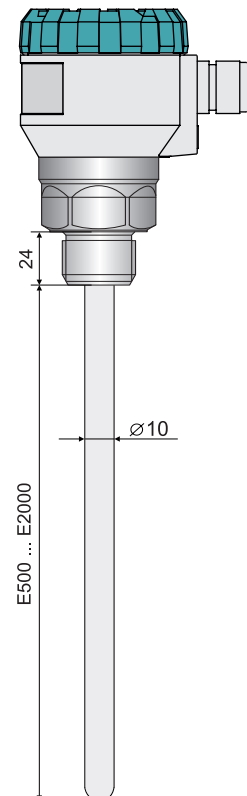

GRLM-70_13

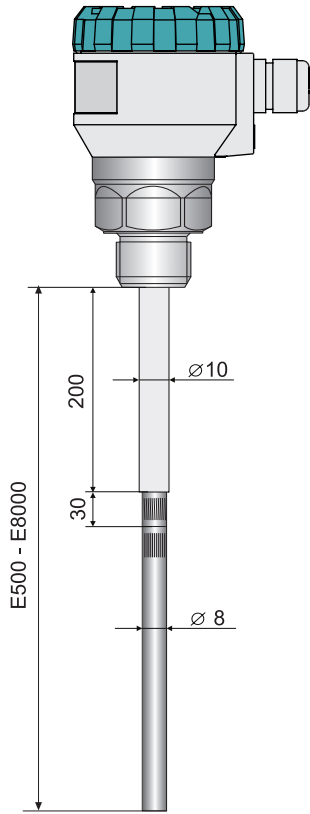

GRLM-70_20

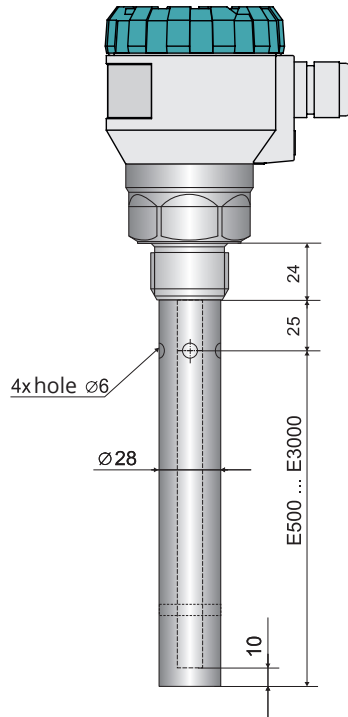

Tri- Clamp

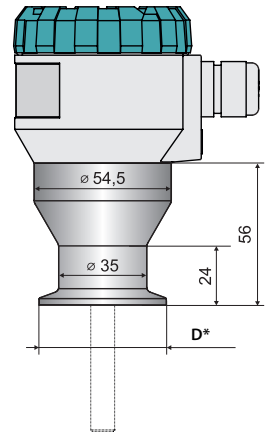

* D: Tri-Clamp Cl50 (Ø 50,5 mm)
Tri-Clamp Cl64 (Ø 64 mm)

GRLM-70_30 (33,34,35)

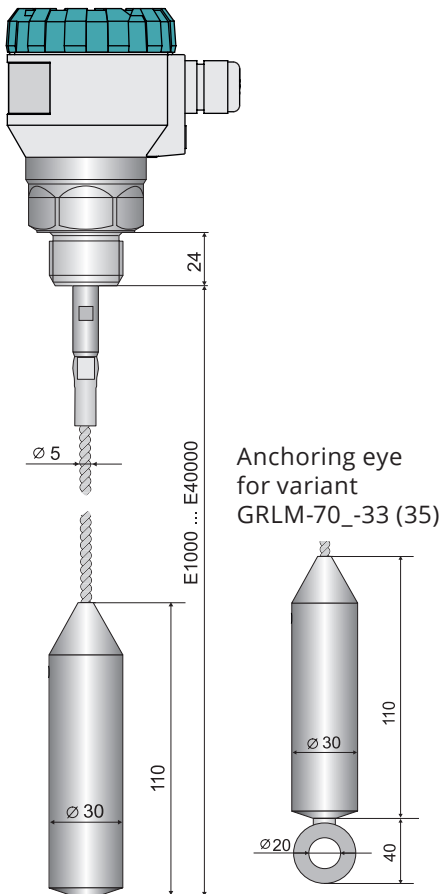

GRLM-70_32

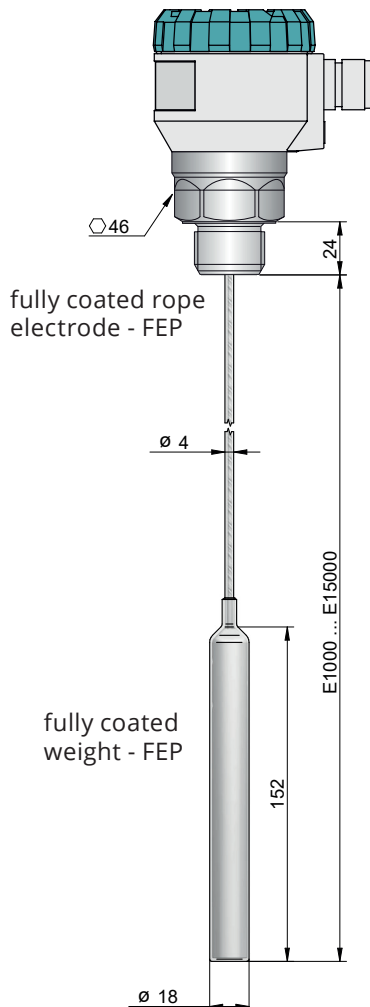

GRLM-70_36 (37)

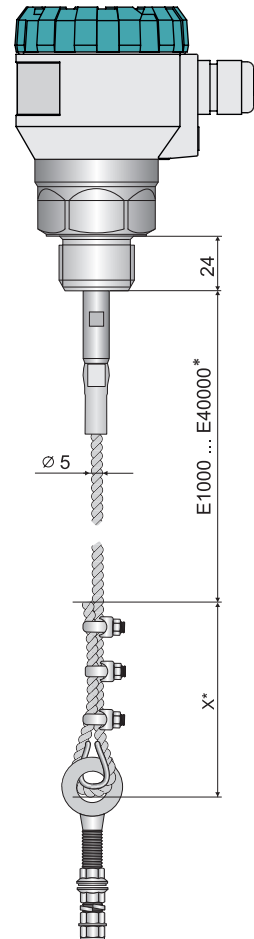

* Please refer to the instructions for the GRLM-70_36(37) version for details on rope length, attachment or shortening.

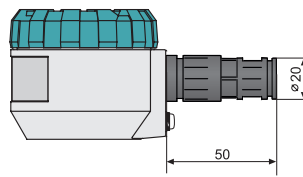
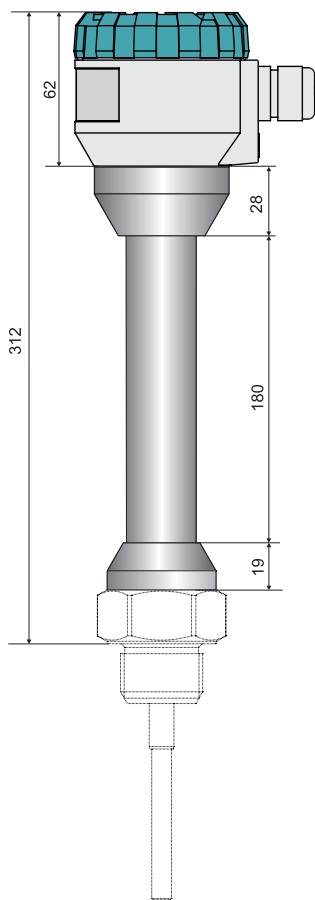

variant "H1"
with protective conductor

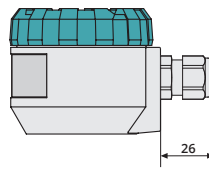

variant "B1, (D1, S1)"
with cable gland M16

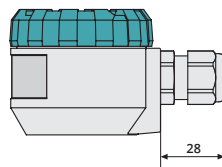

variant "B2 (B3, D2, D3)"
with cable gland M20

BASIC SPECIFICATIONS AND VARIANTS

TECHNICAL SPECIFICATIONS – DISPLAY MODULE

Type of display		matrix OLED, LCD ¹⁾
Resolution		128 x 64 pixels
Height of digits / Number of display digits of measured values		9 mm / 5 digits
Colour of display	OLED LCD	yellow black with white background light
Type of buttons		low lift membrane
Ambient temperature range	OLED LCD	-30 ... +70 °C -20 ... +70 °C
Weight		46 g

¹⁾ OLED- suitable for indoor and low-light applications.

LCD – suitable for outdoor applications particularly with direct sunlight.

USED MATERIALS

unsubmerged parts of the sensor	Variants	Standard material
Lid	all types except GRLM-70NS (70NTS) GRLM-70NS (70NTS)	aluminium alloy with powder coating stainless steel W. Nr. 1.4301 (AISI 304)
Glass	all types	polycarbonate
Body	all types except GRLM-70NS (70NTS) GRLM-70NS (70NTS)	aluminium alloy with powder coating stainless steel W. Nr. 1.4301 (AISI 304)
Display module	all types	plastic material POM
Cable gland	GRLM-70N(NT, Xi, XiT) GRLM-70Xt(XtT) GRLM-70 NS (NTS)	plastic - polyamide metal - nickel-plated brass metallic - stainless steel W. No. 1.4301 (AISI 304)

immersed parts of the sensor	Variants	Standard material
Housing	threaded head Tri-clamp	stainless steel W. Nr. 1.4404 (AISI 316 L) nickel-based alloy (W. Nr. 2.4856 / ALLOY 825) stainless steel W. Nr. 1.4404 (AISI 316 L)
Electrode	GRLM-70_-10 (11,12,13,20) GRLM-70_-30 (32,33,34,35,36,37)	stainless steel W. Nr. 1.4404 (AISI 316 L) stainless steel W. Nr. 1.4401 (AISI 316)
Electrode coating	GRLM-70_-11 GRLM-70_-12, 13 GRLM-70_-32 GRLM-70_-34, 35, 37	PFA FEP FEP PA
Reference tube	GRLM-70_-20	stainless steel W. Nr. 1.4301 (AISI 304)
Weight	GRLM-70_-30	stainless steel W. Nr. 1.4301 (AISI 304)
Weight coating	GRLM-70_-32	FEP
Anchorage	GRLM-70_-33	stainless steel W. Nr. 1.4401 (AISI 316)
Eye rings and clamps	GRLM-70_-36, 37	stainless steel W. Nr. 1.4401 (AISI 316)

PROCESS CONNECTION

type	size	marking
Pipe thread	G 1"	G1 (G1Y)
Pressure thread	NPT 1"	NPT
Jointless connection - Tri-Clamp	ø 50,5 mm ø 64 mm	CI50 CI64

DEVICE CLASSIFICATION

Level meter performance	Type of electrode	Device classification and their use in atmosphere	According to standard EN
GRLM-70N(T)	All types	Basic performance (high-temperature max. 200°C)	-
		For non-explosive atmosphere	-
GRLM-70Xi(XiT)	00, 10, 11, 12, 13, 20, 30, 32, 33	Equipment (high-temperature) protection by intrinsic safety „i” for use in potentially explosion atmosphere, II 1/2 G Ex ia IIB T5 Ga/Gb with intrinsically safe supply units	60079-0, 60079-11
		For use in hazardous area (explosive gas atmosphere) - electrode part zone 0 - housing with electronics zone 1	60079-10-1
GRLM-70Xt(XtT)	00, 10, 30, 33, 34, 35, 36, 37	Equipment dust ignition protection by enclosure „t” for use in potentially explosive atmosphere II 1/2 D Ex ta/tb IIIC T75°C...T300°C Da/Db,	60079-0, 60079-31
		For use in hazardous area (explosive dust atmosphere) - electrode part zone 20 - housing with electronics zone 21	60079-10-2

Further information can be found in the GRLM-70 manual on our website www.dinel.cz

ELECTRICAL CONNECTION

When using the M16 gland, the level meter is connected to the follow-up (evaluation) device using a suitable cable with the outer diameter of 6–8 mm by means of screw terminals located under the display module. The recommended cross section of cores for the current version $2 \times 0,5 \div 0,75 \text{ mm}^2$ and for the version with Modbus communication $2 \times 2 \times 0,25 \text{ mm}^2$ (twisted pair, shielded). In the case of the Modbus version and where it is

assumed that the device will not be at the end of the chain, we recommend using the M20 gland, which is suitable for 2 cables with the \varnothing of 5.5–7.5 mm. Plus pole (+U) is connected to the terminal (+), minus pole (0 V) to the terminal (-) and the shielding (only for shielded cables) to the terminal (≐). Communication wires A and B of the line RS-485 (for version „M“ - Modbus) are connected to the terminals A and B.

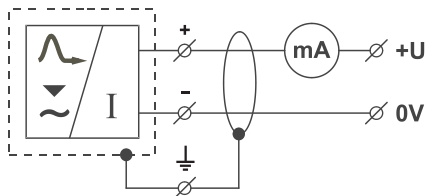

Wiring diagram of the level meter with current output GRLM-70_---I

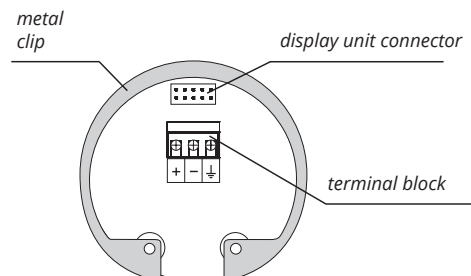

Inside view of screw terminals of the level meter with current output GRLM-70_---I

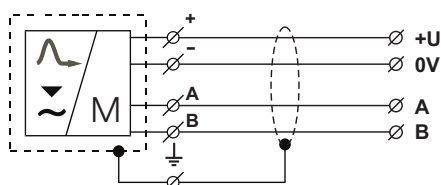

Wiring diagram of the level meter with Modbus GRLM-70_---M

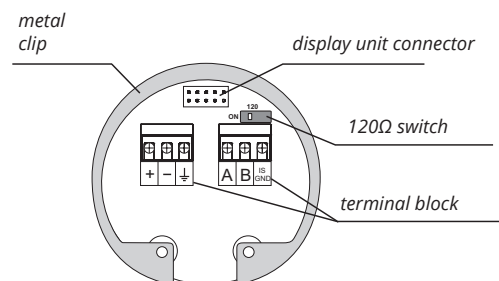

Inside view of screw terminals of the level meter with Modbus GRLM-70_---M

SETTING ELEMENTS

Settings are performed using 3 buttons located on the display module DM-70. All the settings are available in the menu of the level meter.

button

- Set-up mode access
- Confirmation of selected item in the menu
- Move the cursor in the line
- Saving of set-up data

button

- Move in the menu
- Change of values

button

- cancelling of carried out changes
- Shift one level up

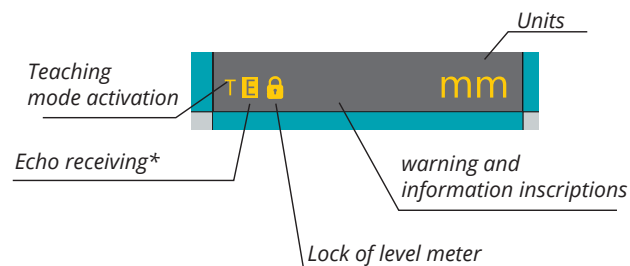
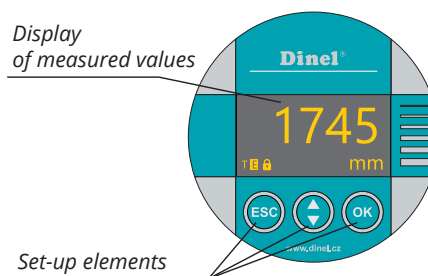





* Slow flashing while the reflected signal (echo) is received from the measured level.

ORDER CODE

GRLM-70

PERFORMANCE

N	basic performance for non-explosive area
NS	for non-explosive area, stainless steel housing and lid, can only be selected for electrical connection S1
NT	high temperature performance for non-explosive area
NTS	high temperature performance for non-explosive area, stainless steel housing and lid, only for S1
Xi	 for hazardous area (explosive gas atmosphere), can only be selected with output type I
Xt	 for hazardous area (explosive dust atmosphere), metal dustproof cable gland required D1, D2, D3
XiT	 high-temperature performance for hazardous area (explosive gas atmosphere), can only be selected with output type I
XtT	 high temperature performance for hazardous area (explosive dust atmosphere), metal dustproof cable gland required D1, D2, D3

TYPE OF ELECTRODE

00	without electrode, CI50 process connection cannot be selected
10	uncoated stainless steel rod electrode, 0,5 ... 8 m, CI50 process connection cannot be selected
11	Fully coated stainless steel rod electrode (PFA), length 0.5 ... 2 m, cannot be selected for the Xt, XtT performance and the NPT process connection cannot be selected
12	Fully coated stainless steel rod electrode (FEP), length 0.5 ... 2 m, cannot be selected for the Xt, XtT performance and the NPT process connection cannot be selected
13	Semi-coated stainless steel rod electrode (FEP), length 0.5 ... 8 m, cannot be selected for the Xt, XtT performance and the NPT process connection cannot be selected
20	Uncoated stainless steel rod electrode with reference tube, length 0.5 ... 3 m, cannot be selected for the Xt, XtT performance, the CI50 and NPT process connections cannot be selected
30	Uncoated stainless steel rope electrode and weight, length 1 ... 40 m, CI50 process connection cannot be selected
32	Fully coated rope electrode (FEP) and weight (FEP), length 1 ... 15 m, cannot be selected for the Xt, XtT performance and the NPT process connection cannot be selected
33	uncoated stainless steel rope electrode with anchorage, electrode length 1 ... 40 m, CI50 process connection cannot be selected
34	coated rope electrode (Polyamide) and uncoated weight, electrode length 1 ... 40 m, cannot be selected for performance Xi, XiT and CI50 process connection cannot be selected
35	coated rope electrode (Polyamide) and uncoated anchorage, electrode length 1 ... 40 m, cannot be selected for performance Xi, XiT and CI50 process connection cannot be selected
36	Uncoated rope electrode without weight, anchoring with rope clamps and eye ring, length 1 ... 40 m, cannot be selected for the Xi, XiT performance and the CI50 process connection
37	Coated rope electrode without weight (polyamide), anchoring with rope clamps and eye ring, length 1 ... 40 m, cannot be selected for the Xi, XiT performance and the CI50 process connection

PROCESS CONNECTION

G1	thread G1", housing material stainless steel (W. Nr. 1.4404 / AISI 316L)
G1Y	thread G1", housing material nickel-based alloy (W. Nr. 2.4856 / ALLOY 825), cannot be selected for performance type 00, 10, 13, 20, 30, 33, 34, 35, 36, 37
CI50	Tri-Clamp Ø 50,5 mm, cannot be selected for performance type 00, 10, 20, 30, 33, 34, 35, 36, 37
CI64	Tri-Clamp Ø 64 mm, cannot be selected for performance type 00, 10, 20, 30, 33, 34, 35, 36, 37
NPT	1" NPT thread cannot be selected for the 11,12, 13, 20, and 32 electrode types and cannot be selected for the NT, XiT, XtT, NTS performance

MATERIAL OF THE INNER O-RING

0	without O-ring, not selectable for electrode type 10, 20, 30, 33, 34, 35, 36, 37 and for Xt and XtT
V	material FPM, not selectable for electrode types 11, 12, 13, 32
E	material EPDM, not selectable for electrode types 11, 12, 13, 32
B	material NBR, not selectable for electrode types 11, 12, 13, 32
F	material FFPM, not selectable for electrode types 11, 12, 13, 32

OUTPUT TYPE

I	current (with HART® communication)
M	RS-485 (Modbus RTU), cannot be selected for performance Xi, XiT

ELECTRICAL CONNECTION

B1	plastic cable gland M16, not possible for the NS, NTS performance
B2	plastic cable gland M20, not possible for the NS, NTS performance
B3	plastic cable gland M20 for 2 cables, not possible for NS, NTS
D1	metal dustproof cable gland M16, not possible for the NS, NTS
D2	metal dustproof cable gland M20, not possible for the NS, NTS
D3	metal dustproof cable gland M20 for 2 cables, not possible for NS, NTS
H1	plastic cable gland for protective hose, not possible for the NS, NTS
S1	stainless steel cable gland M16, only for the NS, NTS

SET-UP ELEMENTS

D	version with OLED display
C	version with LCD display
L	without display, full lid

LENGTH OF ELECTRODE

E	electrode length in mm
----------	------------------------

GRLM-70 N - 10 - G1 - V - I - B1 - D E1000 EXAMPLE OF CODING

ACCESSORIES

1x of seal (asbestos free), other seals (PTFE, Al, etc.) See table in the manual for pressure resistance.	included in the price		
3 pcs stainless steel cable clamp (for the variants 36, 37)	included in the price		
1 pc stainless steel eye ring (for the variants 36, 37)	included in the price		
universal convertor from USB to HART	at extra cost	UHC-01	
convertor (Modbus)	at extra cost	URC-485	
display unit	at extra cost	DM-70	
fixing nuts – stainless steel G1	at extra cost		
steel welding flange	at extra cost	NN-G1 ON-G1	
extension cable for display	at extra cost	PK-70-1	
tightening rope clamp (for the variants 36, 37)	at extra cost		
mounting kit for rope anchoring (for the variants 36, 37)	at extra cost		

SAFETY, PROTECTION, COMPATIBILITY AND EXPLOSION PROOF

The level meter is equipped with protection against fault voltage on the electrode, reverse polarity, short-term overvoltage and current overload on output.

Protection against dangerous contact is provided by low safety voltage according to EN 33 2000-4-41 (SELV). EMC is ensured by conformity with standards EN 55011 (B), EN 61326-1, EN 61000-4-2 (A, 30kV), EN 61000-4-3 (A, 10V), EN 61000-4-4 (A, 2kV), EN 61000-4-5 (A, 2kV), EN 61000-4-6 (A, 10V).

Explosion proof of the GRLM – 70Xi (XiT) performance is ensured by conformity with standards EN IEC 60079-0:2018; EN 60079-11:2012, and EN 60079-26:2007. Explosion proof of GRLM – 70Xi (XiT) is verified by FTZÚ – AO 210 Ostrava – Radvanice: FTZÚ 13 ATEX 0212X.

Explosion proof of the GRLM-70Xt (XtT) performance is ensured by conformity with standards EN IEC 60079-0:2018; EN 60079-31:2014. Explosion proof of GRLM – 70Xt (XtT) is verified by FTZÚ – AO 210 Ostrava – Radvanice: FTZÚ 15 ATEX 0207X.

A declaration of conformity was issued for this device in the wording of Act No. 90/2016 Coll., as amended. The supplied electrical equipment meets the requirements of applicable government regulations on safety and electromagnetic compatibility.

Special conditions for the safe use of the GRLM – 70Xi (XiT) variant

Level meters GRLM-70Xi (XiT) are designed for connection from approved intrinsically safe circuits of power supply units (isolating repeaters) with galvanic isolation. If a device without galvanic isolation (Zener barriers) is used, it is necessary to equalize potentials between the sensor and the grounding point of the barriers.

The limit output parameters of intrinsically safe units must correspond to the limit input parameters of the level meter. When evaluating the intrinsic safety of the circuit, it is necessary to take into account the parameters of the connected cable (especially its inductance and capacity).

The electrode part of GRLM-70Xi (XiT) can be placed in zone 0. Then the housing with electronic circuitry can be placed in zone 1.

Special conditions for the safe use of the GRLM-70Xt (XtT) variant

Ambient temperature of the housing T_a : -30 °C up to +70 °C. For the maximum surface temperature, see Table on p. 55. When installing the variant with a transparent lid, the housing must be protected from direct daylight. The electrode part of GRLM-70Xt (XtT) can be placed in zone 20. Then the housing with electronic circuitry can be placed in zone 21. The housing must be installed to avoid a risk from propagation brush discharges for application in explosive dust atmosphere.

Dinel, s. r. o.

U Tescomy 249, 760 01 Zlín, Czech Republic

tel.: +420 577 002 000

email: sale@dinel.cz

www.dinel.cz

version:
07/2021

