

- For level detection of water in wells, boreholes or tanks
- Stainless steel protection basket avoids mechanical damages of electrode
- Two-wire connection directly to the relay circuit or PLC input (current switch)
- Very easy installation without any adjustment



Submersible level sensor CLS-23S is developed as reliable and low-cost solution for limit level sensing of water (or water solutions) with miniature outer dimensions without the needs of any adjustment. It fully replaces the old type CLS-18S. The connection is done by means of two wires directly to a circuit with relay or to binary input of control system.

FEATURES OF VARIANTS

- **CLS-23S-11** **Insulated (coated) short bar electrode** with stainless steel protection basket. Possible submersion down to 100 m, electrode length 30 mm.

TECHNICAL SPECIFICATIONS	
Supply voltage	6 ... 30 V DC
Supply current – OFF state	Max. 0.6 mA
Switched current (Min / Max)	3.3 / 40 mA
Remanent voltage – ON state	Max. 6 V
Output time delay	0.1 s
Ambient temperature range	-20 ... +70°C
Housing material	Plastic PP
Protection basket material	Stainless steel, plastic PP
Protection class	IP68 (1 MPa)
Cable	PVC 2x 0.75 mm
Weight (without cable)	Approx. 0.2 kg

DIMENSION DRAWING

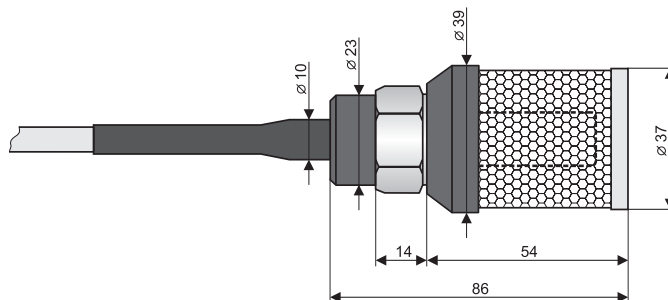

ELECTRICAL CONNECTION

Positive pole (+ U) of power supply is connected through a load (relay) to brown wire, negative pole (0V) is connected to white wire. The sensor output is protected against short circuit. Capacity loads and loads with low sleep resistance (bulb) evaluates the sensor as a short circuit. In the case of connection to evaluation unit or to binary input of the PLC the load is not applied.

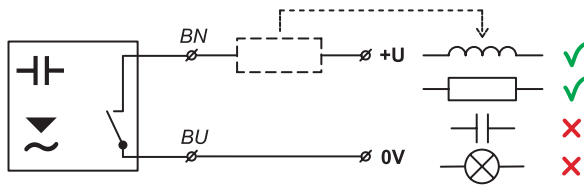

Wiring colours: BN – Brown BU – blue

Note: The sensor is equipped with unshielded cable. In the case of strong electromagnetic interference, or parallel lead with power lines, we recommend to use shielded cable, or contact the manufacturer. In case of installation in remote locations with long cable lead it is needed to insert appropriate surge protection to the line.

INSTALLATION AND RECOMMENDATIONS

Installation of the sensor is done from the top by hanging by the cable. The sensor can operate in any position. The maximum immersion depth is 100 m. The protective basket prevents pollution and damage of the electrode. It is fixed with thread and can be, if necessary (cleaning, etc.), removed.

TYPE OF OUTPUT

	Level state	Mode	Output state
Minimum level sensing		CLS-23S-11-D-SO	CLOSED
		CLS-23S-11-D-SO	OPEN
Maximum level sensing		CLS-23S-11-D-SC	CLOSED
		CLS-23S-11-D-SC	OPEN

For security reasons, we recommend to use **SO variant** (normally open, sensor closes when immersed) for **minimum level detection**. Any failure of the sensor or wiring is equally apparent as the emergency level state. Analogously – for the **maximum level detection** is recommended to use **SC variant** (normally closed, sensor opens when immersed).

AREAS OF APPLICATION

Detection of water and water solutions in boreholes, wells, reservoirs etc.

ORDER CODE

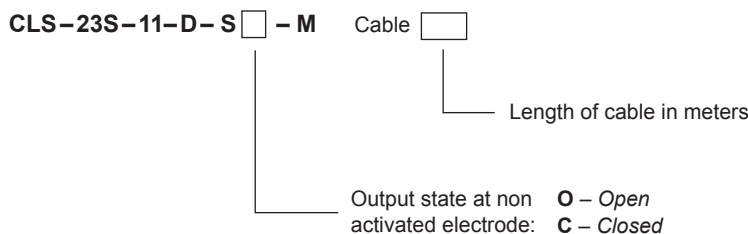

CORRECT SPECIFICATION EXAMPLES

CLS-23S-11-D-SO-M Cable 8m CLS-23S-11-D-SC-M Cable 20m

ACCESSORIES

Standard – included in the level sensors price

- 1 pc of Protection basket

Optional – for extra charge

- Extra cables (over the standard length 2 m)
-

SAFETY, PROTECTIONS AND COMPATIBILITY

The level sensor is equipped with a protection against electric shock on electrode, polarity, overvoltage and short-term current overload on the output.

Electromagnetic compatibility is provided by conformity with standards EN 55011/B, EN 61326-1, EN 61000-4-2 (8 kV), -4-3 (10 V/m), -4-4 (2 kV), -4-5 (1 kV) and -4-6 (10 V).

