

I.1 Caution Statements

Caution Statements cannot cover every potential cause of equipment damage but can highlight common causes of damage. It is the installer's responsibility to read and understand all instructions in this manual prior to installing, operating or maintaining the soft starter, to follow good electrical practice including applying appropriate personal protective equipment and to seek advice before operating this equipment in a manner other than as described in this manual.

- Isolate the soft starter completely from the power supply before attempting any work on the starter or motor.
- Cables to the control inputs must be segregated from mains voltage and motor cabling.
- Some electronic contactor coils are not suitable for direct switching with PCB mount relays. Consult the contactor manufacturer/supplier to confirm suitability.
- Do not apply incorrect voltages to the control input terminals.
- Do not connect power factor correction capacitors to the output of CSX soft starters. If static power factor correction is employed, it must be connected to the supply side of the soft starter.

The examples and diagrams in this manual are included solely for illustrative purposes. The information contained in this manual is subject to change at any time and without prior notice. In no event will responsibility or liability be accepted for direct, indirect or consequential damages resulting from the use or application of this equipment.



WARNING - ELECTRICAL SHOCK HAZARD

CSX soft starters contain dangerous voltages when connected to mains voltage. Only a competent electrician should carry out the electrical installation. Improper installation of the motor or the soft starter may cause equipment failure, serious injury or death. Follow this manual and local electrical safety codes.



GROUNDING AND BRANCH CIRCUIT PROTECTION

It is the responsibility of the user or person installing the soft starter to provide proper grounding and branch circuit protection according to local electrical safety codes.



SHORT CIRCUIT

CSX soft starters are not short circuit proof. After severe overload or short circuit, the operation of the soft starter should be fully tested.

- FR Ce manuel est également disponible en français à partir de www.aucom.com.
- DE Dieses Handbuch ist auch in deutscher Sprache aus www.aucom.com.
- IT Questo manuale è disponibile anche in italiano da www.aucom.com.
- ES Este manual también está disponible en español a partir de www.aucom.com.
- ZH 该手册也可在中国从 www.aucom.com.

Section 2 Mechanical Installation

2.1 Dimensions and Weights

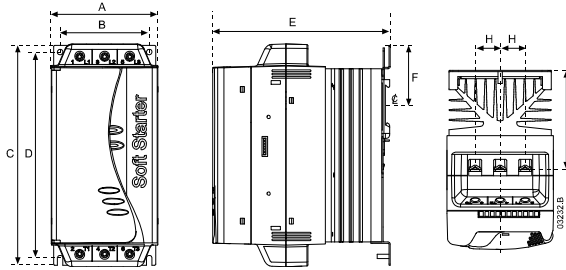

Model	A mm (inch)	B mm (inch)	C mm (inch)	D mm (inch)	E mm (inch)	F mm (inch)	G mm (inch)	H mm (inch)	Weight kg (lb)
CSX-007 CSX-015 CSX-018 CSX-022 CSX-030	98 (3.86)	82 (3.23)	203 (7.99)	188 (7.40)	165 (6.50)	55 (2.17)	90.5 (3.56)	23 (0.9)	2.2 (4.85)
CSX-037 CSX-045 CSX-055	145 (5.71)	124 (4.88)	215 (8.46)	196 (7.71)	193 (7.60)	-	110.5 (4.35)	37 (1.46)	4.0 (8.82)
CSX-075 CSX-090 CSX-110	202 (7.95)	160 (6.30)	240 (9.45)	204 (8.03)	214 (8.43)	-	114.5 (4.50)	51 (2.0)	6.1 (13.45)



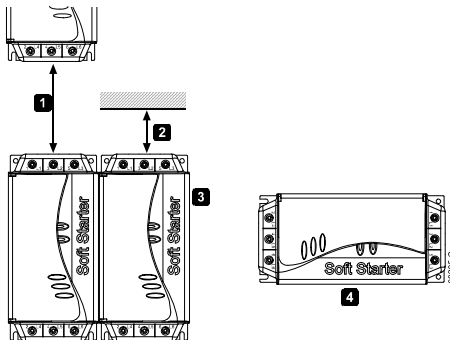







2.2 Physical Installation



1	CSX-007 ~ CSX-055: Allow 100 mm (3.94 inches) between soft starters. CSX-075 ~ CSX-110: Allow 200 mm (7.88 inches) between soft starters.
2	CSX-007 ~ CSX-055: Allow 50 mm (1.97 inches) between the soft starter and solid surfaces. CSX-075 ~ CSX-110: Allow 200 mm (7.88 inches) between the soft starter and solid surfaces.
3	Soft starters may be mounted side by side with no clearance.
4	The soft starter may be mounted on its side. Derate the soft starter's rated current by 15%.

Section 3 Electrical Installation

3.1 Power Terminations

	L1/1, L2/3, L3/5, T1/2, T2/4, T3/6 mm ² (AWG)			A1, A2, A3, 01, 02, B4, B5, 13, 14, 23, 24 mm ² (AWG)	
	007 ~ 030	037 ~ 055	075 ~ 110	007 ~ 110	
	10 - 35 (8 - 2)  14 mm (inch) (0.55)	25 - 50 (4 - 1/0)  14 mm (inch) (0.55)	N.A.	 11 26 9 8.5 (1.02) (0.33)	0.14 - 1.5 (26 - 16)  6 mm (inch) (0.24)
	10 - 35 (8 - 2)  14 mm (inch) (0.55)	25 - 50 (4 - 1/0)  14 mm (inch) (0.55)	N.A.	0.14 - 1.5 (26 - 16)  6 mm (inch) (0.24)	
	Torx (T20) 3 Nm 2.2 ft-lb	Torx (T20) 4 Nm 2.9 ft-lb	N.A.	N.A.	
	7 mm 3 Nm 2.2 ft-lb	7 mm 4 Nm 2.9 ft-lb	N.A.	3.5 mm 0.5 Nm max 4.4 in-lb max	

0218/8

3.2 Control Voltages

CSX soft starters can be supplied in either of two control voltage configurations:

CSX-xxx-xx-C1 110-240 VAC (+ 10% / - 15%) or 380-440 VAC (+ 10% / - 15%)

CSX-xxx-xx-C2 24 VAC/VDC (\pm 20%)



WARNING

Always apply control voltage before (or with) mains voltage.



CAUTION

With 24 VAC/VDC use contacts rated for low voltage and low current (gold flash or similar).

3.3 Control Circuits

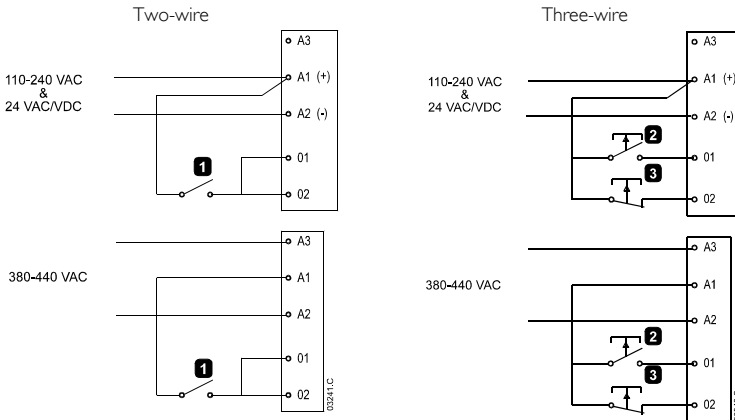

1 Start/stop. To reset a trip, close then open 02.

2 Start.

3 Stop. To reset a trip, close then open 02.



WARNING

Isolate the soft starter completely from the power supply before attempting any work on the starter or motor. Control terminals may be at phase voltage potential.

3.4 Outputs

Main Contactor Output

The Main Contactor output (terminals 13, 14) closes as soon as the soft starter receives a start command and remains closed while the soft starter is controlling the motor (until the motor starts a coast to stop, or until the end of a soft stop). The Main Contactor output will also open if the soft starter trips.

The Main Contactor output can be used to directly control a main contactor coil.

Run Output

The run output relay (terminals 23, 24) can be used to signal run status. This relay is normally open.

The relay operates when the soft start is complete, the bypass relays are closed and full voltage is being applied to the motor. The relay can be used to operate a contactor for power factor correction capacitors, or to signal soft starter run status to an automation system.

3.5 Electrical Schematics

Figure 1: Soft starter installed with a motor protection circuit breaker

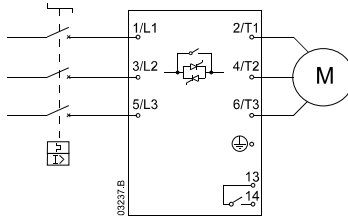

Figure 2: Soft starter installed with a motor protection circuit breaker and main contactor.

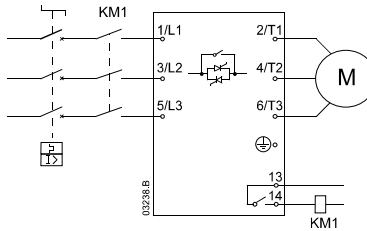
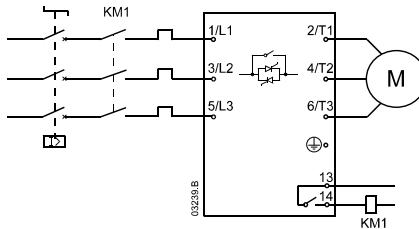
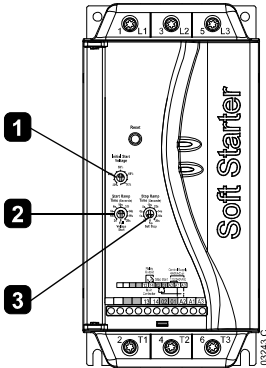

Figure 3: Soft starter installed with a system protection circuit breaker, separate overload and main contactor



M	Motor (three phase)
KM1	Main contactor
13, 14	Main contactor output

Section 4 Adjustments



- 1** Initial Start Voltage
- 2** Start Ramp Time
- 3** Stop Ramp Time

1 Initial Start Voltage

Select the Initial Start Voltage (A).

04978-A

Application	Suggested Initial Start Voltage
Centrifugal Pump	50%
Submersible Pump	60%
Screw Compressor	
Conveyor	
Crusher	70%
Fan	
Other applications	

04978-C

2 Initial Start Time

Select the Initial Start Time (B).

The start ramp defines how long the soft starter will take to increase voltage from the initial start voltage to full voltage. The Initial Start Time does not control the time the motor will take to reach full speed.

1. Set the Initial Start Time to 20 seconds.
2. Set the Initial Start Voltage as required for the application.
3. Attach a current monitoring device to output T1.
4. Start the motor under normal load conditions. Record the time required for the measured current to fall to (or below) the motor's rated full load current (t_i) then stop the motor.
5. Set Initial Start Time = t_i .

NOTE
The Initial Start Time must be long enough for the motor to reach full speed before the soft starter enters bypass mode.

04979-A

04979-C

3 Soft Stop Time

Select the soft stop ramp time (C).

Soft stop extends the time soft starter takes to reduce voltage to zero.

The ramp time does not control the time the motor will take to stop completely.

04980-A

04980-B

Section 5 Troubleshooting



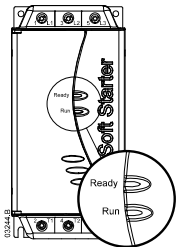

5.1 LEDs



LED Status	Ready	Run
Off	No control power	Motor not running
On	Ready	Motor running at full speed
Flash	Starter tripped	Motor starting or stopping

5.2 Trip Codes

The Ready LED will flash a different number of times to indicate the cause of the trip.

Ready LED	Description
 x 1	Power Circuit: Check mains supply (L1, L2, L3), motor circuit (T1, T2, T3), soft starter SCRs and bypass relays.
 x 6	Supply Frequency: Check mains voltage is available and supply frequency is in range.
 x 8	Network Communication Failure (between interface and network): Check network connections, settings and configuration.
 x 9	Starter Communication Failure (between starter and interface): Remove and refit accessory interface.

Supply Frequency Protection

The soft starter will trip on supply frequency if the frequency rises above 72 Hz or falls below 40 Hz for more than five seconds while the soft starter is running. These trip points are not adjustable.

In pre-start, starting and stopping modes the high and low frequency limits both apply with no time delay.

A supply frequency trip will also occur if:

- all three input phases are lost while the soft starter is running
- all three input phases fall below 120 VAC at start or while the soft starter is running
- the line contactor opens while running

5.3 Reset

Trips can be cleared by pressing the Reset button on the soft starter, sending a Reset command from the serial communications network, or by switching the control inputs.

To clear a trip via the control inputs, the soft starter requires a closed to open transition on the stop input (O2).

- In three wire control, use the external stop pushbutton to momentarily open the stop input (open AI-02).
- In two wire control, if the soft starter tripped with a start signal present, remove the start signal (open AI to O1, O2).

The Reset button is located on the front of the unit, above the adjustment switches.

The soft starter will trip again immediately if the cause of the trip still exists.

Section 6 Accessories

6.1 Finger Guard Kit

Finger guards may be specified for personnel safety and can be used on CSX soft starter models 075~110. Finger guards fit over the soft starter terminals to prevent accidental contact with live terminals. Finger guards provide IP20 protection when used with cable of diameter 22 mm or greater.

6.2 Remote Operator

The Remote Operator can control and monitor the soft starter's performance. Functionality includes:

- Operational control (Start, Stop, Reset, Quick Stop)
- Starter status monitoring (Ready, Starting, Running, Stopping, Tripped)
- Performance monitoring (motor current, motor temperature)
- Trip code display
- 4-20 mA analog output (Motor Current)

6.3 Communication Interfaces

CSX soft starters support network communication using the Profibus, DeviceNet and Modbus RTU protocols.

6.4 Pump Application Interface

The Pump Application Interface expands the soft starter's input and output functionality for applications where greater control and feedback are required.

6.5 PC Software

WinMaster is a purpose-designed software suite for control and monitoring of up to 99 soft starters.

- Operational control (Start, Stop, Reset, Quick Stop)
- Starter status monitoring (Ready, Starting, Running, Stopping, Tripped)

To use WinMaster with the CSX, the soft starter must be fitted with a Modbus Interface or a Remote Operator.

Section 7 Specifications

7.1 General Technical Data

Mains Supply

Mains voltage (L1, L2, L3)	
CSX-xxx-V4	3 x 200 VAC ~ 440 VAC (+ 10% / - 15%)
CSX-xxx-V6	3 x 200 VAC ~ 575 VAC (+ 10% / - 15%)
Mains frequency (at start)	45 Hz to 66 Hz
Rated insulation voltage	600 VAC
Form designation	Bypassed semiconductor motor starter form I

Control Voltage (A1, A2, A3)

CSX-xxx-xx-C1	110-240 VAC (+ 10% / - 15%) or 380-440 VAC (+ 10% / - 15%)
CSX-xxx-xx-C2	24 VAC/VDC (± 20%)
Current consumption (during run)	< 100 mA
Current consumption (inrush)	
CSX-xxx-xx-C1	10 A
CSX-xxx-xx-C2	2 A

Inputs

Start (terminal 01)	Normally open 150 kΩ @ 300 VAC and 5.6 kΩ @ 24 VAC/VDC
Stop (terminal 02)	Normally closed 150 kΩ @ 300 VAC and 5.6 kΩ @ 24 VAC/VDC

Outputs

Main contactor (terminals 13, 14)	Normally open 6 A, 30 VDC resistive / 2 A, 400 VAC, AC11
Run relay (terminals 23, 24)	Normally open 6 A, 30 VDC resistive / 2 A, 400 VAC, AC11

Environmental

Degree of protection CSX-007 to CSX-055	IP20
Degree of protection CSX-075 to CSX-110	IP00
Operating temperature	- 10 °C to + 60 °C
Storage temperature	-25 °C to + 60 °C (to +70 °C for less than 24 hours)
Humidity	5% to 95% Relative Humidity
Pollution degree	Pollution Degree 3
Vibration	IEC 60068 Test Fc Sinusoidal 4 Hz to 13.2 Hz: ± 1 mm displacement 13.2 Hz to 200 Hz: ± 0.7 g

EMC Emission

Equipment class (EMC)	Class A ¹
Conducted radio frequency emission	0.15 MHz to 0.5 MHz: < 90 dB (µV) 0.5 MHz to 5 MHz: < 76 dB (µV) 5 MHz to 30 MHz: 80-60 dB (µV)
Radiated radio frequency emission	30 MHz to 230 MHz: < 30 dB (µV/m) 230 MHz to 1000 MHz: < 37 dB (µV/m)

¹ This product has been designed as Class A equipment. Use of this product in domestic environments may cause radio interference, in which case the user may be required to employ additional mitigation methods.

EMC Immunity

Electrostatic discharge	4 kV contact discharge, 8 kV air discharge
Radio frequency electromagnetic field	0.15 MHz to 1000 MHz: 140 dB (µV)
Rated impulse withstand voltage (Fast transients 5/50 ns)	2 kV line to earth, 1 kV line to line
Voltage dip and short time interruption	100 ms (at 40% nominal voltage)
Harmonics and distortion	IEC61000-2-4 (Class 3), EN/IEC61800-3

Short Circuit

Rated short-circuit current CSX-007 to CSX-037	5 kA
Rated short-circuit current CSX-045 to CSX-110	10 kA

Heat Dissipation

During Start	3 watts / ampere
During Run	10 watts typical

Approvals

C✓	IEC 60947-4-2
UL / C-UL	UL 508
CE	IEC 60947-4-2
CCC	GB 14048.6
Lloyds	IEC 60947-4-2

Operational Life

CSX-007~055	1,000,000 operations
CSX-075~110	30,000 operations

7.2 Model Codes

CSX- - -

Control voltage
 C1 = 110-240 VAC & 380-440 VAC
 C2 = 24 VAC/VDC

Mains voltage
 V4 = 200 ~ 440 VAC
 V6 = 200 ~ 575 VAC

Nominal kW rating @400 VAC
 ≤ 30 kW AC53b 4-6-354
 ≥ 37 kW AC53b 4-6-594

7.3 Current Ratings

	AC53b 4-6:354 < 1000 metres		AC53b 4-20:340 < 1000 metres	
	40 °C	50 °C	40 °C	50 °C
CSX-007	18 A	17 A	17 A	15 A
CSX-015	34 A	32 A	30 A	28 A
CSX-018	42 A	40 A	36 A	33 A
CSX-022	48 A	44 A	40 A	36 A
CSX-030	60 A	55 A	49 A	45 A
	AC53b 4-6:594 < 1000 metres		AC53b 4-20:580 < 1000 metres	
	40 °C	50 °C	40 °C	50 °C
CSX-037	75 A	68 A	65 A	59 A
CSX-045	85 A	78 A	73 A	67 A
CSX-055	100 A	100 A	96 A	87 A
CSX-075	140 A	133 A	120 A	110 A
CSX-090	170 A	157 A	142 A	130 A
CSX-110	200 A	186 A	165 A	152 A

7.4 Semiconductor Fuses

Semiconductor fuses can be used with CSX soft starters to reduce the potential for damage to SCRs from transient overload currents and for Type 2 coordination. CSX soft starters have been tested to achieve Type 2 coordination with semiconductor fuses. Suitable Bussman and Ferraz semiconductor fuses are detailed below.

CSX Model	SCR I ² T (A ² S)	Ferraz Fuse European/IEC Style (North American Style)	Bussmann Fuse Square Body (170M)	Bussmann Fuse British Style (BS88)
007	1150	6.6URD30xxxA0063 (A070URD30xxx0063)	170M-1314	63 FE
015	8000	6.6URD30xxxA0125 (A070URD30xxx0125)	170M-1317	160 FEE
018	10500	6.6URD30xxxA0160 (A070URD30xxx0160)	170M-1318	160 FEE
022	15000	6.6URD30xxxA0160 (A070URD30xxx0160)	170M-1318	180 FM
030	18000	6.6URD30xxxA0160 (A070URD30xxx0160)	170M-1319	180 FM
037	51200	6.6URD30xxxA0250 (A070URD30xxx0250)	170M-1321	250 FM
045	80000	6.6URD30xxxA0315 (A070URD30xxx0315)	170M-1321	250 FM
055	97000	6.6URD30xxxA0315 (A070URD30xxx0315)	170M-1321	250 FM
075	168000	6.6URD31xxxA0450 (A070URD31xxx0450)	170M-1322	500 FMM
090	245000	6.6URD31xxxA0450 (A070URD31xxx0450)	170M-3022	500 FMM
110	320000	6.6URD31xxxA0450 (A070URD31xxx0450)	170M-3022	500 FMM

xxx = Blade Type. Contact Ferraz for options.

