

I Important User Information

Observe all necessary safety precautions when controlling the soft starter remotely. Alert personnel that machinery may start without warning.

It is the installer's responsibility to follow all instructions in this manual and to follow correct electrical practice.

Use all internationally recognised standard practice for RS485 communications when installing and using this equipment.

2 Installation

2.1 Physical installation

1. Fully pull out the top and bottom retaining clips on the interface.
2. Line up the interface with the comms port slot.
3. Push in the top and bottom retaining clips to secure the interface to the starter.

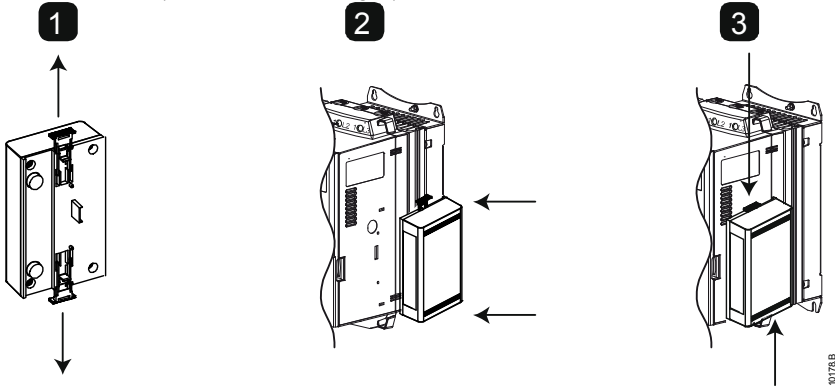

MVS and MVX:
Plug the interface onto the back of the controller.

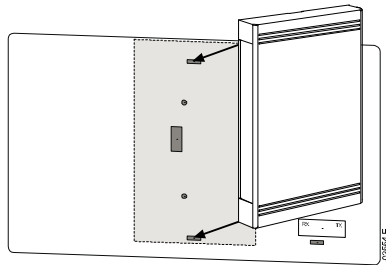

CAUTION

Remove mains and control voltage from the soft starter before attaching or removing accessories. Failure to do so may damage the equipment.

Remove the interface using the following procedure:

1. Take the interface off-line.
2. Remove control power and mains supply from the soft starter.
3. Disconnect all field wiring from the interface.
4. Fully pull out the top and bottom retaining clips on the interface.
5. Pull the interface away from the soft starter.

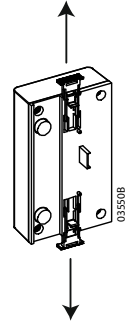

2.2 Adjustment

Network communication parameters must be set on the Modbus Interface. DIP switch settings take effect on the power-up of the Modbus Interface via the soft starter.

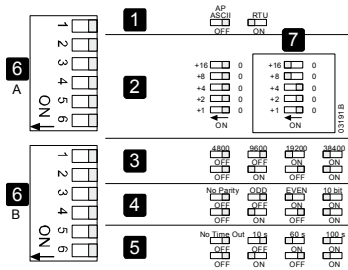

1	Protocol
2	Address
3	Baud rate
4	Parity
5	Timeout (seconds)
6	DIP switch
7	Example: Address = 24

2.3 Master Configuration

For standard Modbus 11-bit transmission, the Master must be configured for 2 stop bits with No Parity and 1 stop bit for odd or even parity.

For 10-bit transmission, the Master must be configured for 1 stop bit.

In all cases, the Master baud rate and slave address must match those set on the Modbus Interface DIP switches.

2.4 Connection

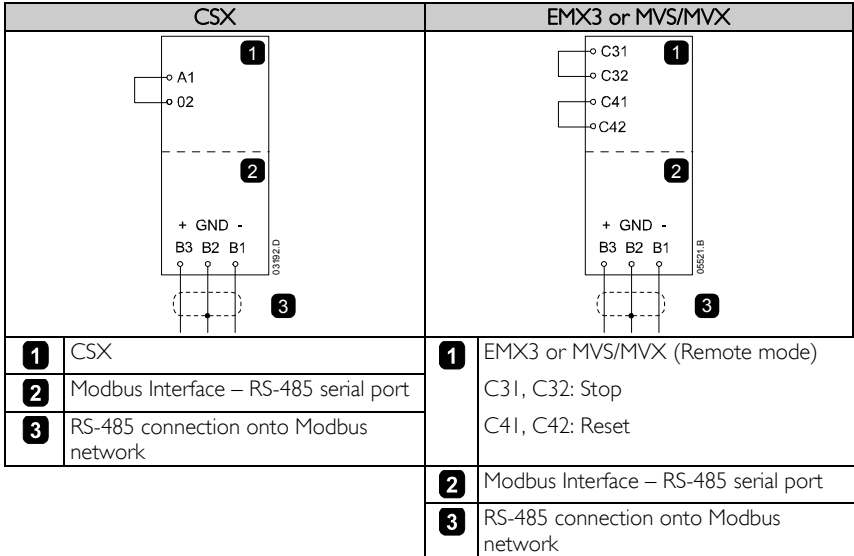

CSX: For the Modbus Interface to accept serial commands, a link must be fitted across terminals A1-02 on the soft starter.

EMX3 and MVS/MVX: Input links are required across the stop and reset inputs if the soft starter is being operated in Remote mode. In Local mode, links are not required.



NOTE

EMX3 and MVS/MVX: Parameter *Comms in Remote* selects whether the soft starter will accept Start and Stop commands from the Serial Network Master while in Remote Mode. Refer to the soft starter user manual for parameter details.

3 LEDs

The Network Status LED (I) indicates the state of the communications link between the interface and the network. LED operation is as follows:

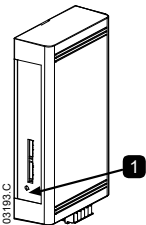

1	Off	No connection or soft starter not powered up
	On	Communication active
	Flashing	Communication inactive



NOTE

If communication is inactive, the soft starter may trip if the Communications Timeout function has been set on the interface. When communication is restored, the soft starter will require a Reset.

4 Modbus Functions

The Modbus Interface supports the following Modbus functions:

- 03 Read multiple registers
- 06 Write single register
- 16 Write multiple registers

Modbus broadcast functions are not supported.

CSX soft starters (including Remote Operator):

- Read multiple registers 40003 to 40008
- Write single register 40002

EMX3 and MVS/MVX soft starters:

- Read multiple registers starting from 40003 up to a maximum of 119 register blocks.
- Single write register 40002 or multiple write registers 40009 to 40599.



NOTE

A multiple read across register boundary 40008/40009 will result in a Modbus Error code 05 at the Master.

4.1 Modbus Register



NOTE

Some soft starters do not support some functions.

Registers 40600 and above are not compatible with CSX Series soft starters. For CSX, use registers 40002~40008.

All registers are multiple read/write unless otherwise stated.

Register	Description	Bits	Details
40002	Command (single write)	0 to 2	To send a command to the starter, write the required value: 1 = Start 2 = Stop 3 = Reset 4 = Quick stop (coast to stop) 5 = Forced communication trip 6 = Start using Parameter Set 1 ¹ 7 = Start using Parameter Set 2 ¹
		3 to 7	<i>Reserved</i>
40003	Starter status	0 to 3	1 = Ready 2 = Starting 3 = Running 4 = Stopping (including braking) 5 = Restart delay (including temperature check) 6 = Tripped 7 = Programming mode 8 = Jog forward 9 = Jog reverse
		4	1 = Positive phase sequence (only valid if bit 6 = 1)

Register	Description	Bits	Details	
		5	1 = Current exceeds FLC	
		6	0 = Uninitialised 1 = Initialised	
		7	0 = Remote Operator communications are OK 1 = Remote Operator/Communications device fault	
40004	Trip code	0 to 7	Refer to Trip Code table.	
40005 ²	Motor current	0 to 7	Average 3 phase motor current (A)	
40006	Motor temperature	0 to 7	Motor 1 temperature (thermal model)	
40007	Product information	0 to 2	Product parameter list version	
		3 to 7	Product type code ³	
40008	Serial Protocol Version	0 to 7		
40009 ⁴	Parameter management Single or multiple read or write	0 to 7	Manage soft starter programmable parameters.	
40600	Version	0 to 5	Binary protocol version number	
		6 to 8	Parameter list version number	
		9 to 15	Product type code ³	
40601	<i>Reserved</i>			
40602 ⁵	Changed parameter number	0 to 7	0 = parameters not changed 1~255 = index number of the last parameter changed	
		8 to 15	Total number of parameters available in the starter	
40603 ⁵	Changed parameter value	0 to 13	Value of the last parameter that was changed, as indicated in register 40602	
		14 to 15	<i>Reserved</i>	
40604	Starter state	0 to 4	0 = <i>Reserved</i> 1 = Ready 2 = Starting 3 = Running 4 = Stopping 5 = Not ready (restart delay, restart temperature check, run simulation) 6 = Tripped 7 = Programming mode 8 = Jog forward 9 = Jog reverse	
		5	1 = Warning	
		6	0 = Unintialised 1 = Initialised	
		7	0 = Local control 1 = Remote control	
		8	0 = Parameter(s) have changed since last parameter read 1 = No parameters have changed ⁵	

MODBUS INTERFACE

Register	Description	Bits	Details
		9	0 = Negative phase sequence 1 = Positive phase sequence
		10 to 15	Trip/warning code (refer to trip codes) ⁶
40605 ²	Current	0 to 13 14 to 15	Average rms current across all three phases <i>Reserved</i>
40606	Current	0 to 9 10 to 15	Current (% motor FLC) <i>Reserved</i>
40607	Motor temperature	0 to 7 8 to 15	Motor 1 thermal model (%) Motor 2 thermal model (%)
40608 ⁷	Power	0 to 11 12 to 13 14 to 15	Power Power scale <i>Reserved</i>
40609	% Power factor	0 to 7 8 to 15	100% = power factor of 1 <i>Reserved</i>
40610	Voltage	0 to 13 14 to 15	Average rms voltage across all three phases <i>Reserved</i>
40611 ²	Current	0 to 13 14 to 15	Phase 1 current (rms) <i>Reserved</i>
40612 ²	Current	0 to 13 14 to 15	Phase 2 current (rms) <i>Reserved</i>
40613 ²	Current	0 to 13 14 to 15	Phase 3 current (rms) <i>Reserved</i>
40614	Voltage	0 to 13 14 to 15	Phase 1 voltage (rms) <i>Reserved</i>
40615	Voltage	0 to 13 14 to 15	Phase 2 voltage (rms) <i>Reserved</i>
40616	Voltage	0 to 13 14 to 15	Phase 3 voltage (rms) <i>Reserved</i>
40617	Parameter list version	0 to 7 8 to 15	Parameter list minor revision Parameter list major version
40618	Digital Input state	0 to 15	For all inputs, 0=open, 1=closed (shorted) 0 = Start 1 = Stop 2 = Reset 3 = Input A 4 = Input B 5 = Input C, if fitted 6 = Input D, if fitted 7 to 15 = <i>Reserved</i>
40619~ 40631	<i>Reserved</i>		

¹ Ensure that the programmable input is not set to Motor Set Select before using this function.

² For models EMX3-0053B and smaller this value will be 10 times greater than the value displayed on the keypad.

³ Product type code:

4 = CSX Series

5 = MVS (two-line controller)

6 = EMX3
 10 = MVX
 11 = MVS (four-line controller)

⁴ Refer to the relevant soft starter literature for a complete parameter list. The first product parameter is always allocated to register 40009. The last product parameter is allocated to register 40XXX, where XXX = 008 plus total number of available parameters in the product.

⁵ Reading register 40603 (Changed parameter value) will reset registers 40602 (Changed parameter number) and 40604 (Parameters have changed). Always read registers 40602 and 40604 before reading register 40603.

⁶ Bits 10~15 of register 40604 report the soft starter's trip or warning code. If the value of bits 0~4 is 6, the soft starter has tripped. If bit 5 = 1, a warning has activated and the starter is continuing to operate.

⁷ Powerscale functions as follows:

0 = multiply Power by 10 to get W
 1 = multiply Power by 100 to get W
 2 = Power is represented in kW
 3 = multiply Power by 10 to get kW

4.2 Trip Codes

Trip Code	Description	CSX	CSX ⁱ	EMX3	MVS and MVX
1	Excess start time		●	●	●
2	Motor overload (thermal model)		●	●	●
3	Motor thermistor		●	●	●
4	Current imbalance		●	●	●
5	Frequency (Mains supply)	●	●	●	●
6	Phase sequence		●	●	●
7	Instantaneous overcurrent			●	●
8	Power loss/Power circuit	●	●	●	●
9	Undercurrent			●	●
10	Heatsink (starter) overtemperature			●	●
11	Motor connection			●	●
12	Input A trip/Auxiliary Trip A			●	●
13	FLC too high/FLC out of range			●	●
14	Unsupported option (function not available in inside delta)			●	
15	Starter communication (between interface and soft starter)	●	●	●	●
16	Network communication (between interface and network)	●	●	●	●
17	Internal fault x (where x is the fault code detailed in the table below).			●	●
20 ¹	Ground fault			●	●
23	Parameter out of Range			●	●
24	Input B trip/Auxiliary Trip B			●	●
25	Bypass fail (bypass contactor)			●	●
26	L1 phase loss			●	●

MODBUS INTERFACE

27	L2 phase loss			●	●
28	L3 phase loss			●	●
29	L1-T1 shorted			●	●
30	L2-T2 shorted			●	●
31	L3-T3 shorted			●	●
32	Motor 2 overload (thermal model)			●	●
33 ²	Time-overcurrent (Bypass overload)	●		●	
34	SCR overtemperature				●
35	Battery/clock			●	●
36	Thermistor circuit			●	
37	RTD A overtemperature			●	
38 ¹	RTD B overtemperature			●	
39 ¹	RTD C overtemperature			●	
40 ¹	RTD D overtemperature			●	
41 ¹	RTD E overtemperature			●	
42 ¹	RTD F overtemperature			●	
43 ¹	RTD G overtemperature			●	
45	RTD circuit fail			●	
46	Analog input trip			●	●
255	No trip	●	●	●	●

¹ Available with EMX3 only if the appropriate option card is fitted.

² For EMX3, time-overcurrent protection is only available on internally bypassed models.

4.3 Internal Fault x

The table below details the internal fault code associated with trip code 17.

Internal fault	Message displayed on the keypad
70 ~ 72	Current Read Err Lx
73	ATTENTION! Remove Mains Volts
74 ~ 76	Motor connection Tx
77 ~ 79	Firing fail SCRx
80 ~ 82	VZC Fail Px
83	Low Control Volts
84 ~ 98	Internal fault X Contact your local supplier with the fault code (X).

4.4 Examples

Command: Start

Message	Starter Address	Function Code	Register Address	Data	CRC
In	20	06	40002	1	CRC1, CRC2
Out	20	06	40002	1	CRC1, CRC2

Starter status: Running

Message	Starter Address	Function Code	Register Address	Data	CRC
In	20	03	40003	1	CRC1, CRC2
Out	20	03	2	xxxx0011	CRC1, CRC2

Trip code: Motor overload

Message	Starter Address	Function Code	Register Address	Data	CRC
In	20	03	40004	1	CRC1, CRC2
Out	20	03	2	00000010	CRC1, CRC2

Download parameter from starter

EMX3 and MVS/MVX: Read Parameter 3, *Locked Rotor Current* (Parameter 1C), 600%

Message	Starter Address	Function Code	Register Address	Data	CRC
In	20	03	40011	1	CRC1, CRC2
Out	20	03	2 (bytes)	600	CRC1, CRC2

Upload single parameter to starter

EMX3 and MVS/MVX: Write Parameter 12, *Stop Mode* (Parameter 2H), set = 1

Message	Starter Address	Function Code	Register Address	Data	CRC
In	20	06	40020	1	CRC1, CRC2
Out	20	06	40020	1	CRC1, CRC2

Upload multiple parameters to starter

EMX3 and MVS/MVX: Write Parameters 6, 7, 8 (parameters 2B *Start Ramp Time*, 2C *Initial Current*, 2D *Current Limit*). Set to values of 15 seconds, 300%, 350% respectively.

Message	Starter Address	Function Code	Register Address	Data	CRC
In	20	16	40014,3	15, 300,350	CRC1, CRC2
Out	20	16	40014,3	15, 300,350	CRC1, CRC2



NOTE

This function can only be used to upload consecutive parameter blocks. The Register Address data indicates the number of parameters to be uploaded, and the register address of the first parameter.



NOTE

Parameter information can only be uploaded/downloaded from EMX3 and MVS/MVX starters.

5 Modbus Error Codes

Code	Description	Example
01	Illegal function code	Function other than 03 or 06
02	Illegal data address	Register number invalid
03	Not readable data	Register not allowed for data reading
04	Not writable data	Register not allowed for data writing
05	Data boundary fault	Multiple data transfer across data boundary or data size more than 125
06	Invalid command code	eg writing "6" into 40003
07	Illegal parameter read	Invalid parameter number
08	Illegal parameter write	Invalid parameter number, read only, or hidden parameter
09	Unsupported command	Sending a serial command to EMX3 with parameter <i>Comms in Remote</i> = Disable control in RMT or to MVS/MVX with parameter <i>Comms in Remote</i> = Disable in Remote.
10	Local communication error	Communication error between Modbus slave and starter



NOTE

Some of the above codes are different from those defined in the Modbus Application Protocol Specification available on www.modbus.org.

6 Modbus Control via Remote Operator

The Modbus Interface can be used to connect a Remote Operator to the soft starter, enabling control via an RS-485 serial communications network. Refer to the Remote Operator instructions for details.

6.1 Grounding and Shielding

Twisted pair data cable with earth shield is recommended. The cable shield should be connected to the GND device terminal at both ends and one point of the site protective earth.

6.2 Termination Resistors

In long cable runs prone to excessive noise interference, termination resistors should be installed between the data lines at both ends of the RS485 cable. This resistance should match the cable impedance (typically 120 Ω). Do not use wire wound resistors.

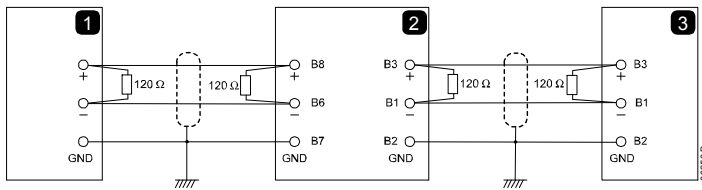

1	Network master RS-485
2	Remote Operator RS-485
3	Soft starter RS-485

6.3 RS-485 Data Cable Connection

Daisy chain connection is recommended. This is achieved by parallel connections of the data cable at the actual device terminals.

6.4 Remote Operator RS-485 Network Connection Specifications

Input impedance: 12 kΩ
 Common mode voltage range: - 7 V to + 12 V
 Input sensitivity: ± 200 mV
 Minimum differential output voltage: 1.5 V (with max loading of 54 Ω)

7 Specifications

Enclosure

Dimensions	40 mm (W) x 166 mm (H) x 90 mm (D)
Weight	250 g
Protection	IP20

Mounting

Spring-action plastic mounting clips (x 2)

Connections

Soft starter	6-way pin assembly
Network	5-way male and unpluggable female connector (supplied)
Maximum cable size	2.5 mm ²

Settings

Protocol	Modbus RTU, AP ASCII
Address range	0 to 31
Data rate (bps)	4800, 9600, 19200, 38400
Parity	None, Odd, Even, 10-bit
Timeout	None (off), 10 s, 60 s, 100 s

Certification

C✓	IEC 60947-4-2
CE	IEC 60947-4-2
RoHS	Compliant with EU Directive 2002/95/EC

