

Managing DC Energy

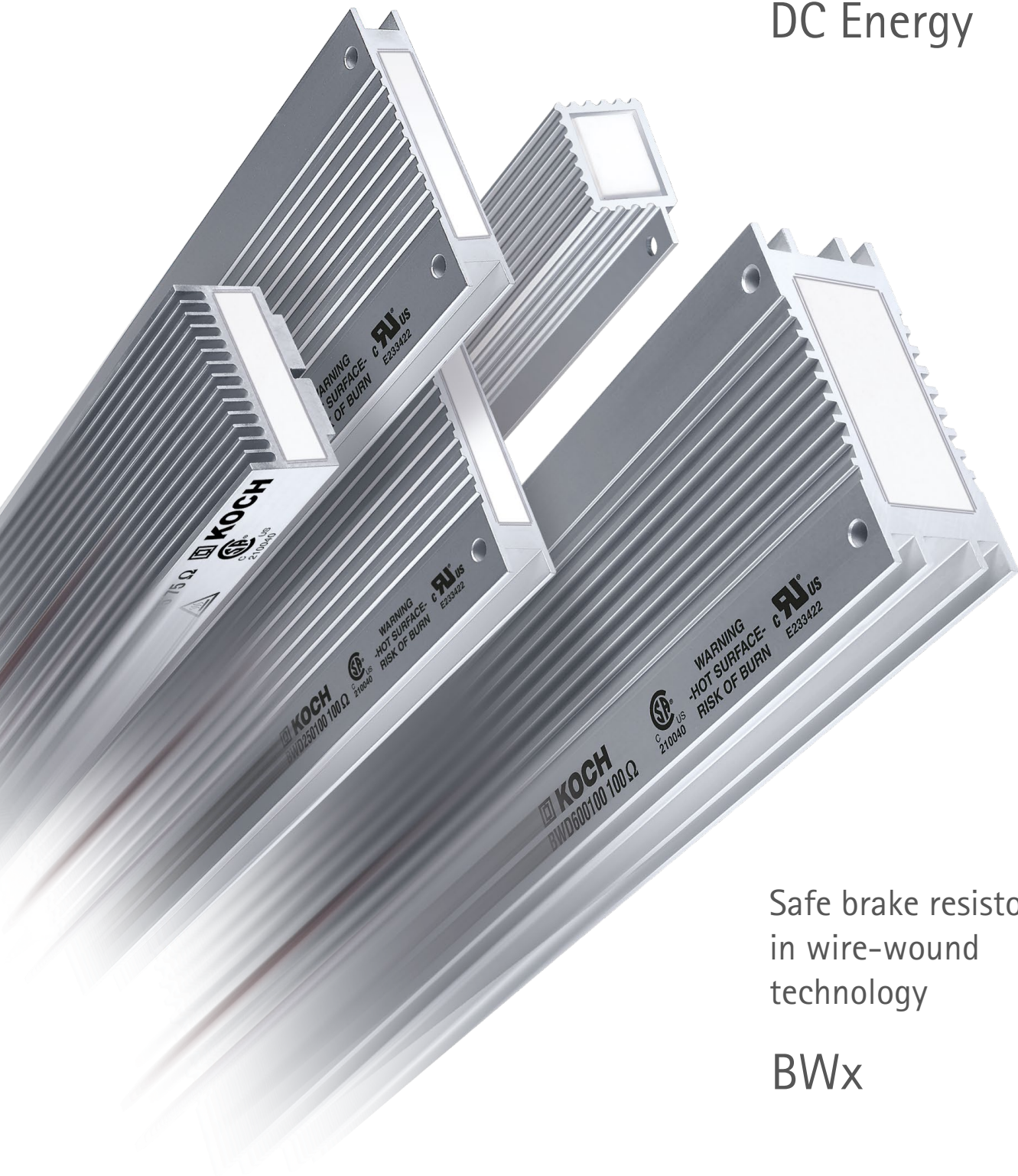

Safe brake resistors
in wire-wound
technology

BWx

Brake resistor BWx150

Short-circuit proof, „intrinsically safe“ resistor for use in inverters (brake transistors) in an aluminum case, IP65* protection class.



Rated power (W)

60 (150 with duty cycle)
ED = 35%, $\vartheta_A = 20^\circ\text{C}$

Resistance (Ohm)

75, 300

Dimensions (mm)

Enclosure: 80 x 52 x 28
Wiring: length 510±40
Ø AWG16 or 1.5 mm²
PTFE isolated, UL Style 1659

Technical specifications

($\vartheta_A = 20^\circ\text{C}$, unless otherwise specified)

Parameter	Symbol	Value	Unit	Conditions
Tolerance (resistance)		± 5	%	Room temperature
Temperature coefficient	TK	20 ... 100	10 ⁻⁶ /K	
Insulation resistance	R _{ISO}	≥ 100	MΩ	U _{mess} = 1,000 VDC
Inductance	L	≤ 30	μH	f = 300 kHz, U _{mess} = 50 mV
Capacity against enclosure	C	≤ 300	pF	f = 300 kHz, U _{mess} = 50 mV
Thermal time constant	τ	approx. 250	s	
Weight	m	230	g	
Certifications	cCSAus			Standard CSA-C22.2 and UL508
Energy absorption	Q	2.2	kJ	with 1.2 s (1% duty cycle)
		4.4	kJ	with 7.2 s (6% duty cycle)
Maximum permissible operating voltage	U _B	≤ 700 AC	V	Taking into consideration the „intrinsic safety“ according to cCSAus
		≤ 1,000 DC	V	
		≤ 600 AC	V	
		≤ 848 DC	V	
Isolation voltage	U _{iso}	≥ 4,000 AC	V	f = 50 Hz; t = 1 s
Max. permissible case temp.	ϑ _c	≤ 250	°C	unobstructed convection
Storage temperature	ϑ _s	-25 ... +85	°C	



Versions



BWD150



BWS150



BWS150 with customer specific connector

Dimensions (mm)

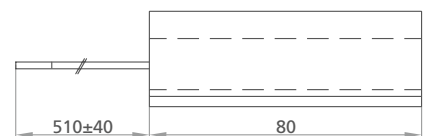
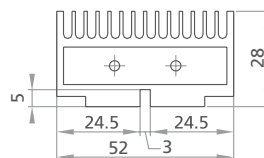

Pulse loading capacity

Brake resistor BWx150

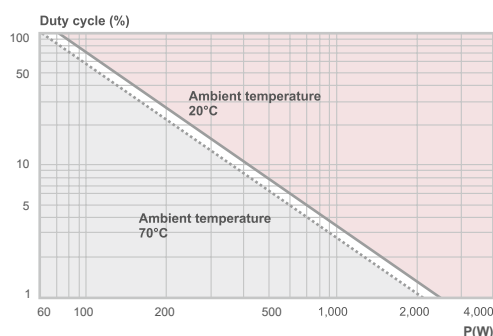

Case temperature

Brake resistor BWx150

With duty cycle ED = 100%
Maximum permissible temperature T = 250 °C

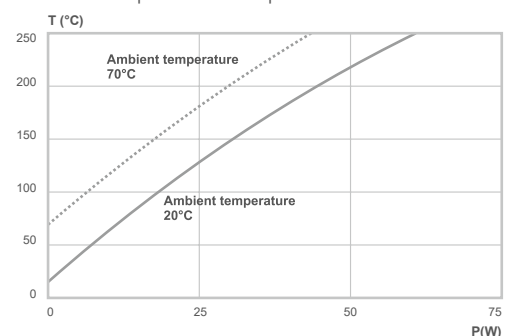

* Test conditions: Water jet from nozzle 6.3 mm inside diameter, flow rate 12.5 l / min +/- 5%, water pressure according to volume flow, distance 2.5-3m, test duration 3min

Brake resistor BWx200

Short-circuit proof, „intrinsically safe“ resistor for use in inverters (brake transistors) in an aluminum case, IP65* protection class.



Rated power (W)
50 (100 with forced cooling)

Resistance (Ohm)
90

Dimensions (mm)
Enclosure: 105 x 22 x 36.5
Wiring: length 290±20
Ø AWG16 or 1.5 mm²
PTFE isolated, UL Style 1659

Technical specifications
($\vartheta_A = 20^\circ\text{C}$, unless otherwise specified)

Parameter	Symbol	Value	Unit	Conditions
Tolerance (resistance)		± 5	%	Room temperature
Temperature coefficient	TK	40 ... 65	10 ⁻⁶ /K	
Insulation resistance	R _{ISO}	≥ 100	MΩ	U _{mess} = 1,000 VDC
Inductance	L	≤ 30	μH	f = 300 kHz, U _{mess} = 50 mV
Capacity against enclosure	C	≤ 300	pF	f = 300 kHz, U _{mess} = 50 mV
Thermal time constant	τ	approx. 700	s	Heating phase free in air
		approx. 1,000		Cooling phase free in air
Weight	m	155	g	
Certifications	cURus**			Standard CSA-C22.2 and UL508
Energy absorption	Q	2.4	kJ	with 1.2 s (1% duty cycle)
		3.6	kJ	with 7.2 s (6% duty cycle)
Maximum permissible operating voltage	U _B	≤ 700 AC	V	Taking into consideration the „intrinsic safety“ according to UL
		≤ 1,000 DC	V	
		≤ 600 AC	V	
		≤ 848 DC	V	
Isolation voltage	U _{iso}	≥ 4,000 AC	V	f = 50 Hz; t = 1 s
Max. permissible case temp.	ϑ _c	≤ 200	°C	in consideration of UL and forced cooling
Storage temperature	ϑ _s	-25 ... +85	°C	



Versions



BWD200



BWS200



BWS200 with customer specific connector

Dimensions and mounting holes (mm)

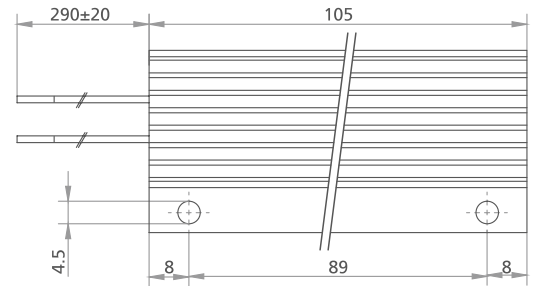
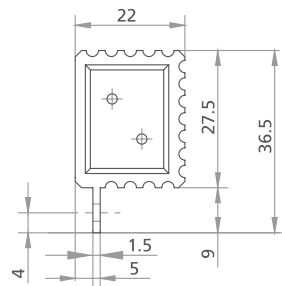

Pulse loading capacity

Brake resistor BWx200

— 120s / free in air

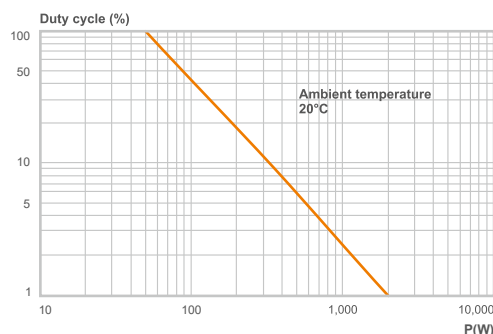

Case temperature

Brake resistor BWx200

profile temperature averaged with duty cycle ED = 100%
Maximum permissible temperature T = 250 °C

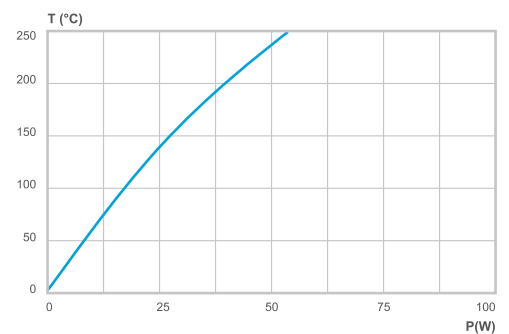

* Test conditions: Water jet from nozzle 6.3 mm inside diameter, flow rate 12.5 l / min +/- 5%, water pressure according to volume flow, distance 2.5-3m, test duration 3min
** Certification only valid in customer specific application

Brake resistor BWx250

Short-circuit proof, „intrinsically safe“ resistor for use in inverters (brake transistors) in an anodized aluminum case, IP65* protection class.



Rated power (W)
100 (250 with duty cycle
ED = 35%, $\vartheta_A = 20^\circ\text{C}$)

Resistance (Ohm)
3, 10, 24, 27, 33, 47, 72, 100, 150,
200, 220, 330, 390, 430, 620, 830

Dimensions (mm)
Enclosure: 110 x 80 x 15
Wiring: length 510±40
Ø AWG16 or 1.5 mm²
PTFE isolated, UL Style 1659



Technical specifications ($\vartheta_A = 20^\circ\text{C}$, unless otherwise specified)

Parameter	Symbol	Value	Unit	Conditions
Tolerance (resistance)		± 5	%	Room temperature
Temperature coefficient	TK	20 ... 100	10 ⁻⁶ /K	
Insulation resistance	R _{ISO}	≥ 100	MΩ	U _{mess} = 1,000 VDC
Inductance	L	≤ 30	μH	f = 300 kHz, U _{mess} = 50 mV
Capacity against enclosure	C	≤ 300	pF	f = 300 kHz, U _{mess} = 50 mV
Thermal time constant	τ	approx. 550	s	
Weight	m	280	g	
Certifications	cCSAus cURus			Standard CSA-C22.2 and UL508 Standard CSA-C22.2 and UL508
Energy absorption	Q	4 8	kJ	with 1.2 s (1% duty cycle) with 7.2 s (6% duty cycle)
Maximum permissible operating voltage	U _B	≤ 700 AC ≤ 1,000 DC ≤ 600 AC ≤ 848 DC	V V V V	Taking into consideration the „intrinsic safety“ according to cCSAus and UL
Isolation voltage	U _{iso}	≥ 4,000 AC	V	f = 50 Hz; t = 1 s
Max. permissible case temp.	ϑ _C	≤ 250	°C	unobstructed convection
Storage temperature	ϑ _S	-25 ... +85	°C	

Versions



BWD250



BWG250



BWS250



BWT250
without CSA and UL approval

Dimensions and mounting holes (mm)

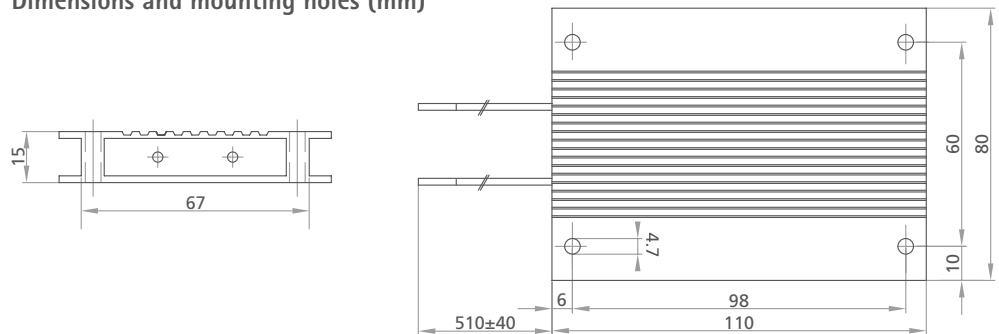

Pulse loading capacity Brake resistor BWx250

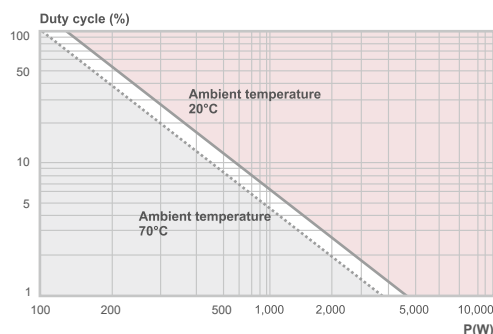

Case temperature

Brake resistor BWx250
With duty cycle ED = 100%
Maximum permissible temperature T = 250 °C

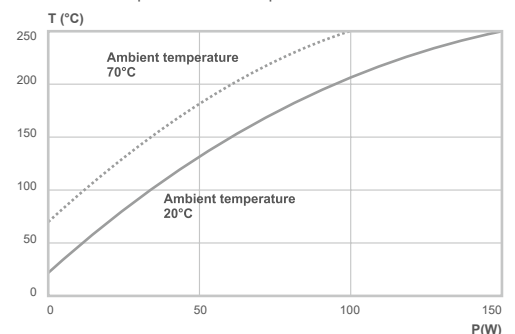

* Test conditions: Water jet from nozzle 6.3 mm inside diameter, flow rate 12.5 l / min +/- 5%, water pressure according to volume flow, distance 2.5-3m, test duration 3min

Brake resistor BWx350

Short-circuit proof, „intrinsically safe“ resistor for use in inverters (brake transistors) in an aluminum case, IP65* protection class.



Rated power (W)
75 (150 with forced cooling)

Resistance (Ohm)
45

Dimensions (mm)
Enclosure: 185 x 36 x 31.6
Wiring: length 330±20
Ø AWG16 or 1.5 mm²
PTFE isolated, UL Style 1659

Technical specifications
($\vartheta_A = 20^\circ\text{C}$, unless otherwise specified)

Parameter	Symbol	Value	Unit	Conditions
Tolerance (resistance)		± 5	%	Room temperature
Temperature coefficient	TK	40 ... 65	10 ⁻⁶ /K	
Insulation resistance	R _{ISO}	≥ 100	MΩ	U _{mess} = 1,000 VDC
Inductance	L	≤ 30	μH	f = 300 kHz, U _{mess} = 50 mV
Capacity against enclosure	C	≤ 300	pF	f = 300 kHz, U _{mess} = 50 mV
Thermal time constant	τ	approx. 750 approx. 1,080	s	Heating phase free in air Cooling phase free in air
Weight	m	257	g	
Certifications	cURus**			Standard CSA-C22.2 and UL508
Energy absorption	Q	3.8 5.4	kJ	with 1.2 s (1% duty cycle) with 7.2 s (6% duty cycle)
Maximum permissible operating voltage	U _B	≤ 700 AC ≤ 1,000 DC ≤ 600 AC ≤ 848 DC	V V V V	Taking into consideration the „intrinsic safety“ according to UL
Isolation voltage	U _{iso}	≥ 4,000 AC	V	f = 50 Hz; t = 1 s
Max. permissible case temp.	ϑ _c	≤ 200	°C	in consideration of UL and forced cooling
Storage temperature	ϑ _s	-25 ... +85	°C	



Versions



BWD350



BWS350



BWS350 with customer specific connector

Dimensions and mounting holes (mm)

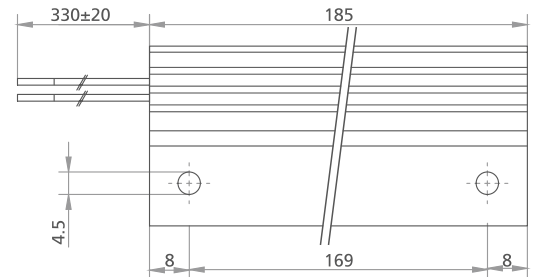
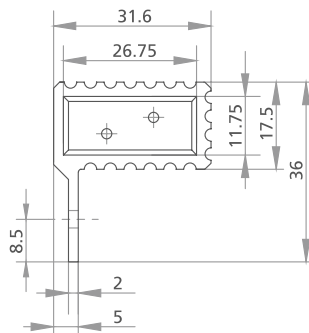

Pulse loading capacity

Brake resistor BWx350

— 120s / free in air

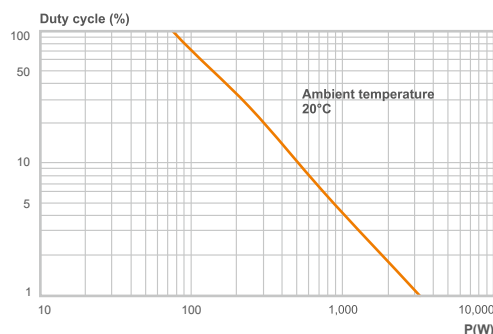

Case temperature

Brake resistor BWx350

profile temperature averaged — free in air with duty cycle ED = 100%
Maximum permissible temperature T = 250 °C

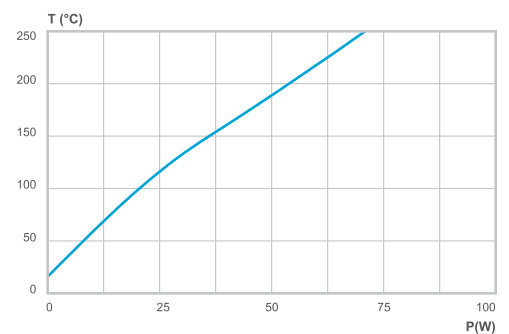

* Test conditions: Water jet from nozzle 6.3 mm inside diameter, flow rate 12.5 l / min +/- 5%, water pressure according to volume flow, distance 2.5-3m, test duration 3min
** Certification only valid in customer specific application

Brake resistor BWx375

Short-circuit proof, „intrinsically safe“ resistor for use in inverters (brake transistors) in an aluminum case, IP65* protection class.



Rated power (W)
70 (150 with forced cooling)

Resistance (Ohm)
90

Dimensions (mm)
Enclosure: 185 x 22 x 36.5
Wiring: length 290±20
Ø AWG16 or 1.5 mm²
PTFE isolated, UL Style 1659

Technical specifications ($\vartheta_A = 20^\circ\text{C}$, unless otherwise specified)

Parameter	Symbol	Value	Unit	Conditions
Tolerance (resistance)		± 5	%	Room temperature
Temperature coefficient	TK	40 ... 65	10 ⁻⁶ /K	
Insulation resistance	R _{ISO}	≥ 100	MΩ	U _{mess} = 1,000 VDC
Inductance	L	≤ 30	μH	f = 300 kHz, U _{mess} = 50 mV
Capacity against enclosure	C	≤ 300	pF	f = 300 kHz, U _{mess} = 50 mV
Thermal time constant	τ	approx. 850 approx. 1,200	s	Heating phase free in air Cooling phase free in air
Weight	m	260	g	
Certifications	cURus**			Standard CSA-C22.2 and UL508
Energy absorption	Q	3.6 5.0	kJ	with 1.2 s (1% duty cycle) with 7.2 s (6% duty cycle)
Maximum permissible operating voltage	U _B	≤ 700 AC ≤ 1,000 DC ≤ 600 AC ≤ 848 DC	V V V V	Taking into consideration the „intrinsic safety“ according to UL
Isolation voltage	U _{iso}	≥ 4,000 AC	V	f = 50 Hz; t = 1 s
Max. permissible case temp.	ϑ _c	≤ 200	°C	in consideration of UL and forced cooling
Storage temperature	ϑ _s	-25 ... +85	°C	



Versions



BWD375



BWS375



BWS375 with customer specific connector

Dimensions and mounting holes (mm)

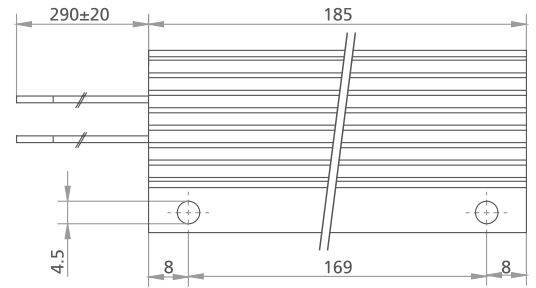
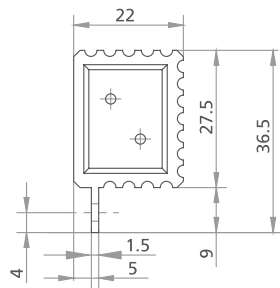

Pulse loading capacity

Brake resistor BWx375

— 120s / free in air

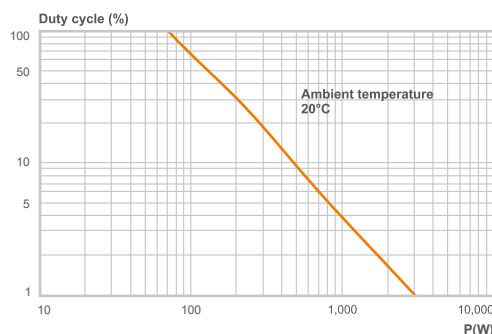

Case temperature

Brake resistor BWx375

profile temperature averaged — free in air with duty cycle ED = 100%
Maximum permissible temperature T = 250 °C

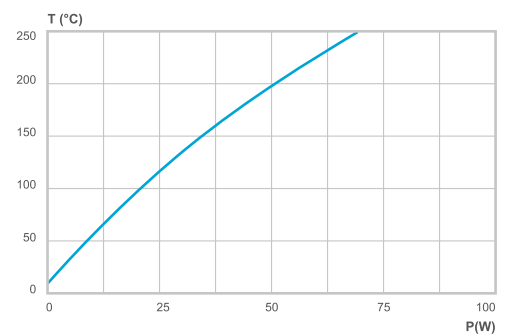

* Test conditions: Water jet from nozzle 6.3 mm inside diameter, flow rate 12.5 l / min +/- 5%, water pressure according to volume flow, distance 2.5-3m, test duration 3min
** Certification only valid in customer specific application

Brake resistor BWx500

Short-circuit proof, „intrinsically safe“ resistor for use in inverters (brake transistors) in an anodized aluminum case, IP65* protection class.



Rated power (W)

200 (500 with duty cycle)
ED = 35%, $\vartheta_A = 20^\circ\text{C}$

Resistance (Ohm)

10, 12, 15, 22, 27, 35, 40, 47, 50, 60, 72, 100, 130, 150, 160, 200, 210, 240, 300, 310, 430, 620

Dimensions (mm)

Enclosure: 216 x 80 x 15
Wiring: length 510±40
Ø AWG16 or 1.5 mm²
PTFE isolated, UL Style 1659



Technical specifications

($\vartheta_A = 20^\circ\text{C}$, unless otherwise specified)

Parameter	Symbol	Value	Unit	Conditions
Tolerance (resistance)		± 5	%	Room temperature
Temperature coefficient	TK	20 ... 100	10 ⁻⁶ /K	
Insulation resistance	R _{ISO}	≥ 100	MΩ	U _{mess} = 1,000 VDC
Inductance	L	≤ 30	μH	f = 300 kHz, U _{mess} = 50 mV
Capacity against enclosure	C	≤ 300	pF	f = 300 kHz, U _{mess} = 50 mV
Thermal time constant	τ	approx. 550	s	
Weight	m	550	g	
Certifications	cCSAus cURus			Standard CSA-C22.2 and UL508 Standard CSA-C22.2 and UL508
Energy absorption	Q	7.5 15	kJ	with 1.2 s (1% duty cycle) with 7.2 s (6% duty cycle)
Maximum permissible operating voltage	U _B	≤ 700 AC ≤ 1,000 DC ≤ 600 AC ≤ 848 DC	V V V V	Taking into consideration the „intrinsic safety“ according to cCSAus and UL
Isolation voltage	U _{iso}	≥ 4,000 AC	V	f = 50 Hz; t = 1 s
Max. permissible case temp.	ϑ _C	≤ 250	°C	unobstructed convection
Storage temperature	ϑ _S	-25 ... +85	°C	

Versions



BWD500



BWG500



BWS500



BWT500
without CSA and UL approval

Dimensions and mounting holes (mm)

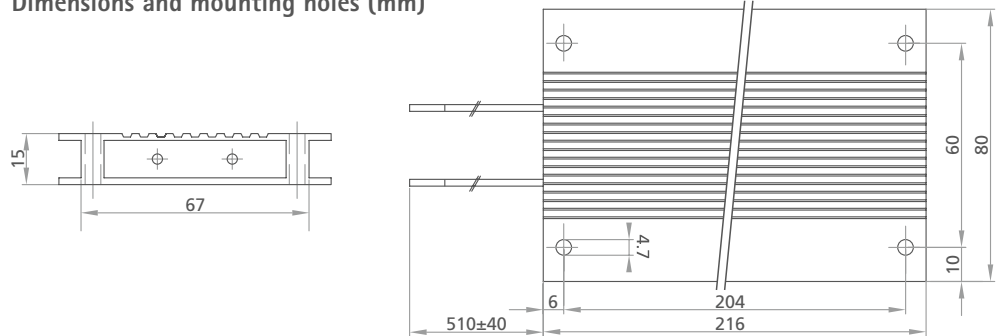

Pulse loading capacity

Brake resistor BWx500

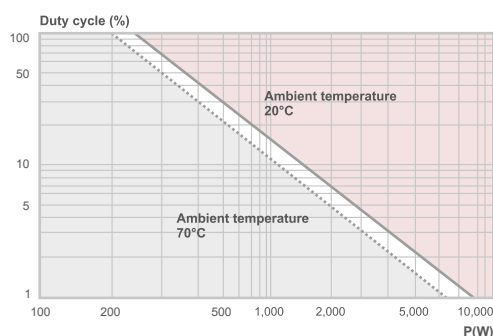

Case temperature

Brake resistor BWx500

With duty cycle ED = 100%
Maximum permissible temperature T = 250 °C

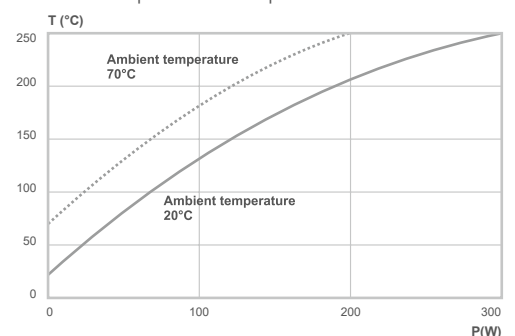

* Test conditions: Water jet from nozzle 6.3 mm inside diameter, flow rate 12.5 l / min +/- 5%, water pressure according to volume flow, distance 2.5-3m, test duration 3min

Brake resistor BWx600

Short-circuit proof, „intrinsically safe“ resistor for use in inverters (brake transistors) in an anodized aluminum case, IP65* protection class.



Rated power (W)
240 (600 with duty cycle
ED = 35%, $\vartheta_A = 20^\circ\text{C}$)

Resistance (Ohm)
5, 10, 14, 18, 22, 27, 33, 47, 72,
80, 100, 150, 200, 220, 300

Dimensions (mm)
Enclosure: 216 x 80 x 30
Wiring: length 510±40
Ø AWG16 or 2.5 mm²
PTFE isolated, UL Style 1659

Technical specifications ($\vartheta_A = 20^\circ\text{C}$, unless otherwise specified)

Parameter	Symbol	Value	Unit	Conditions
Tolerance (resistance)		± 5	%	Room temperature
Temperature coefficient	TK	20 ... 100	10 ⁻⁶ /K	
Insulation resistance	R _{ISO}	≥ 100	MΩ	U _{mess} = 1,000 VDC
Inductance	L	≤ 30	μH	f = 300 kHz, U _{mess} = 50 mV
Capacity against enclosure	C	≤ 300	pF	f = 300 kHz, U _{mess} = 50 mV
Thermal time constant	τ	approx. 600	s	
Weight	m	1,050	g	
Certifications	cCSAus cURus			Standard CSA-C22.2 and UL508 Standard CSA-C22.2 and UL508
Energy absorption	Q	13 26	kJ	with 1.2 s (1% duty cycle) with 7.2 s (6% duty cycle)
Maximum permissible operating voltage	U _B	≤ 700 AC ≤ 1,000 DC ≤ 600 AC ≤ 848 DC	V V V V	Taking into consideration the „intrinsic safety“ according to cCSAus and UL
Isolation voltage	U _{iso}	≥ 4,000 AC	V	f = 50 Hz; t = 1 s
Max. permissible case temp.	ϑ _C	≤ 250	°C	unobstructed convection
Storage temperature	ϑ _S	-25 ... +85	°C	



Versions



BWD600

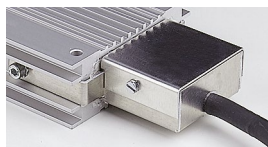

BWG600



BWS600



BWT600
without CSA and UL approval

Dimensions and mounting holes (mm)

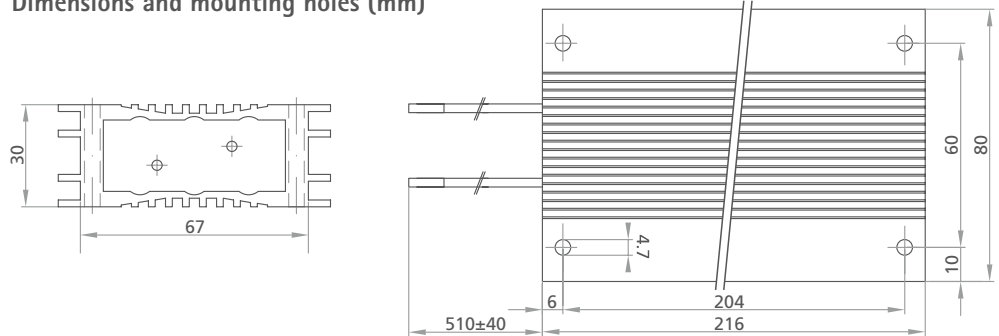

Pulse loading capacity Brake resistor BWx600

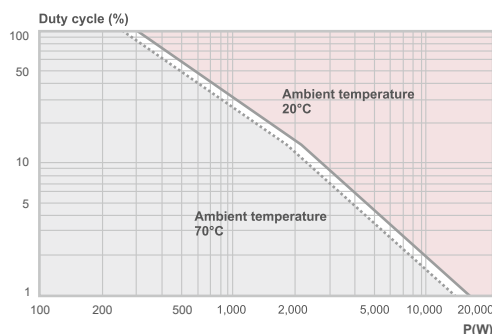

Case temperature

Brake resistor BWx600
With duty cycle ED = 100%
Maximum permissible temperature T = 250 °C

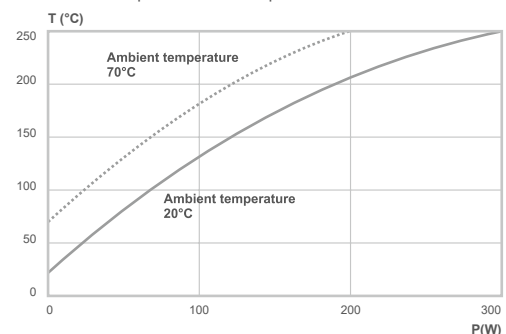

* Test conditions: Water jet from nozzle 6.3 mm inside diameter, flow rate 12.5 l / min +/- 5%, water pressure according to volume flow, distance 2.5-3m, test duration 3min

Brake resistor BWx1000

Short-circuit proof, „intrinsically safe“ resistor for use in inverters (brake transistors) in an anodized aluminum case, IP65* protection class.



Rated power (W)
400 (1.000 with duty cycle
ED = 35%, $\vartheta_A = 20^\circ\text{C}$)

Resistance (Ohm)
5, 10, 14, 18, 22, 27, 33, 47, 72,
80, 100, 150, 200, 220, 300

Dimensions (mm)
Enclosure: 216 x 80 x 30
Wiring: length 510±40
Ø AWG16 or 2.5 mm²
PTFE isolated, UL Style 1659

Technical specifications
($\vartheta_A = 20^\circ\text{C}$, unless otherwise specified)

Parameter	Symbol	Value	Unit	Conditions
Tolerance (resistance)		± 5	%	Room temperature
Temperature coefficient	TK	20 ... 100	10 ⁻⁶ /K	
Insulation resistance	R _{ISO}	≥ 100	MΩ	U _{mess} = 1,000 VDC
Inductance	L	≤ 30	μH	f = 300 kHz, U _{mess} = 50 mV
Capacity against enclosure	C	≤ 300	pF	f = 300 kHz, U _{mess} = 50 mV
Thermal time constant	τ	approx. 850	s	
Weight	m	1,050	g	
Energy absorption	Q	13	kJ	with 1.2 s (1% duty cycle)
		26	kJ	with 7.2 s (6% duty cycle)
Maximum permissible operating voltage	U _B	≤ 700 AC	V	Taking into consideration the „intrinsic safety“
Isolation voltage	U _{ISO}	≤ 1,000 DC	V	f = 50 Hz; t = 1 s
Max. permissible case temp.	ϑ _C	≤ 300	°C	unobstructed convection
Storage temperature	ϑ _S	-25 ... +85	°C	



Versions



BWD1000

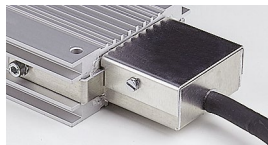

BWG1000



BWS1000



BWT1000

Dimensions and mounting holes (mm)

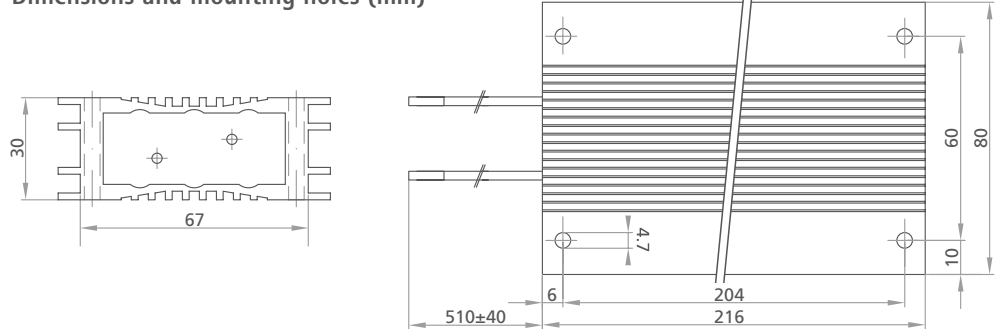

**Pulse loading capacity
Brake resistor BWx1000**

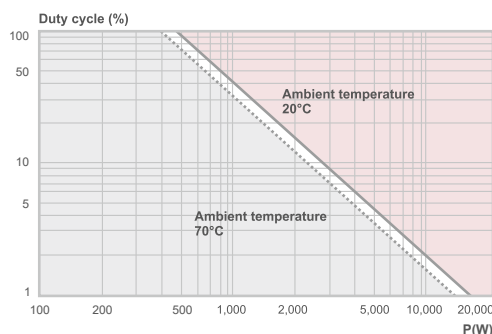

Case temperature

Brake resistor BWx1000
With duty cycle ED = 100%
Maximum permissible temperature T = 300 °C

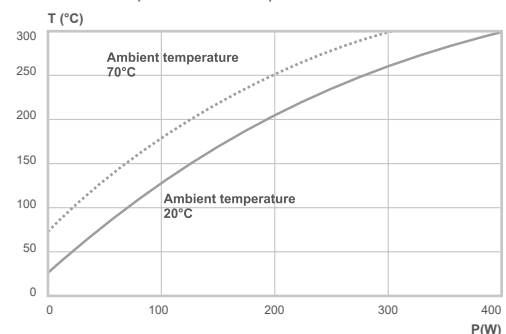

* Test conditions: Water jet from nozzle 6.3 mm inside diameter, flow rate 12.5 l / min +/- 5%, water pressure according to volume flow, distance 2.5-3m, test duration 3min

Managing DC Energy

Active Energy Management Solutions and Safe Brake Resistors for Electric Drives

We offer:

- **Tested product quality**
- **Certified processes**
– we undergo regular inspections by third parties
- **Individual application support**
– owing to our modular system we can offer more than 60.000 solutions
- **Machine-specific implementation**
– we match our products with your machines
- **High reaction rate**
– we provide you with a suitable offer in the shortest possible time
- **Short delivery times**
– all components are available from stock
- **On-time deliveries every time**
– we deliver on schedule in optimal lot sizes
- **Reliable partner**
– we strive for long-term business relationships
- **Direct customer relationships**

www.brakeenergy.com



www.brakeenergy.com



www.facebook.com/michaelkochgmbh



blog.bremsenergie.de



www.xing.com/companies/michaelkochgmbh



www.newsletter.bremsenergie.de



www.youtube.com/user/MichaelKochGmbH



Appstore



www.linkedin.com/company/michael-koch-gmbh

We look forward to hearing from you!



Michael Koch GmbH, Zum Grenzgraben 28, D-76698 Ubstadt-Weiher
Phone (+49) 7251 / 96 26 20, Fax (+49) 7251 / 96 26 21
www.brakeenergy.com, mail@brakeenergy.com

Technische Änderungen vorbehalten. MK_DAT_BWX_DEU_R00_0

