

VACON[®] 100
VACON[®] 100 FLOW
AC DRIVES

INSTALLATION MANUAL

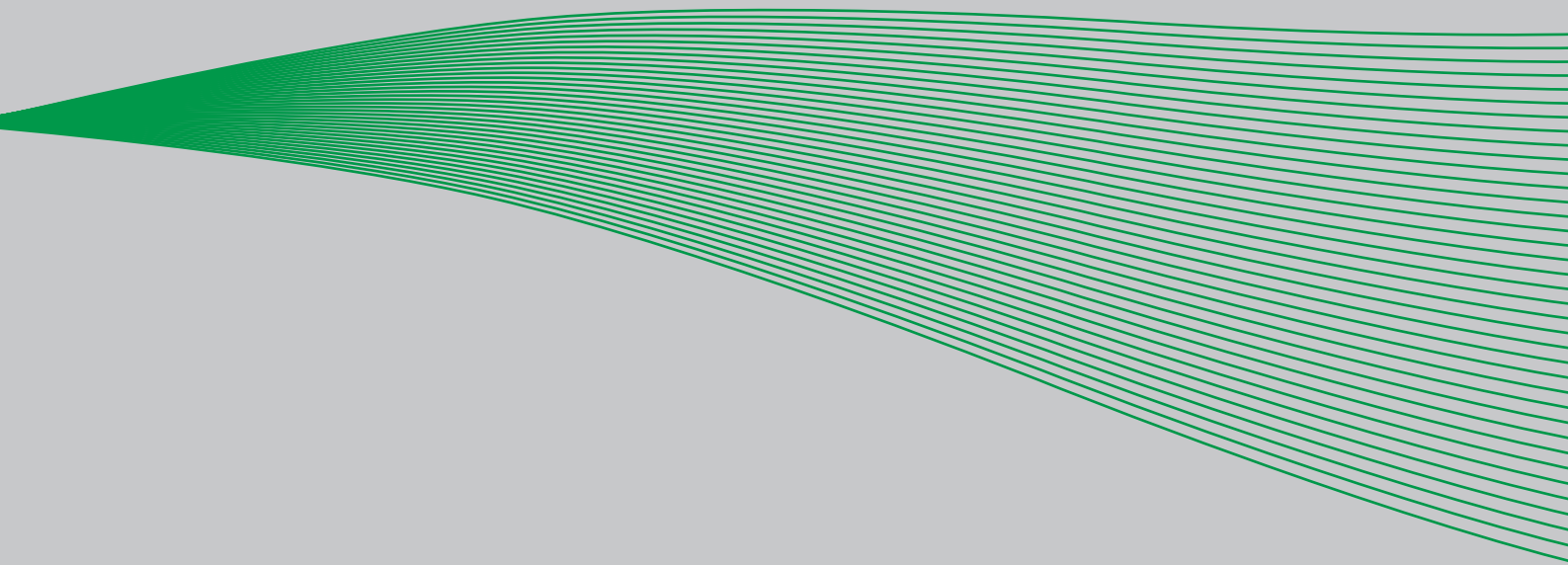

TABLE OF CONTENTS

Document: DPD00873D
 Order code: DOC-INS04123+DLUK
 Rev. D
 Version release date: 7.11.12

1. Approvals	3
1.1 EC Declaration of conformity	3
1.2 UL approval	3
1.3 C-tick approval	3
2. Safety	5
2.1 Danger	5
2.2 Warnings	6
2.3 Earthing and earth fault protection	7
2.4 Electro-magnetic compatibility (EMC).....	8
2.5 Compability with RCDs.....	8
3. Receipt of delivery.....	9
3.1 Type designation code.....	10
3.2 Unpacking and lifting the AC drive	11
3.2.1 Lifting frames MR8 and MR9	11
3.3 Accessories	13
3.3.1 Frame MR4.....	13
3.3.2 Frame MR5.....	13
3.3.3 Frame MR6.....	14
3.3.4 Frame MR7.....	14
3.3.5 Frame MR8.....	14
3.3.6 Frame MR9.....	15
3.4 'Product modified' sticker.....	16
3.5 Disposal.....	16
4. Mounting.....	17
4.1 Dimensions.....	17
4.1.1 Wall mount	17
4.1.2 Flange mount	24
4.2 Cooling.....	33
5. Power cabling.....	35
5.1 UL standards on cabling	37
5.1.1 Cable dimensioning and selection.....	37
5.2 Brake resistor cables.....	42
5.3 Cable installation	42
5.3.1 Frames MR4 to MR7.....	43
5.3.2 Frames MR8 and MR9.....	49
5.4 Installation in corner-grounded network	59
6. Control unit	60
6.1 Control unit cabling.....	61
6.1.1 Control cable sizing.....	61
6.1.2 Control terminals and DIP switches.....	62
6.2 Fieldbus connection	64
6.2.1 Prepare for use through ethernet	65
6.2.2 Prepare for use through RS485.....	66
6.3 Option board installation.....	70
6.4 Battery installation for Real Time Clock (RTC).....	73

6.5	Galvanic isolation barriers	74
7.	Commissioning	75
7.1	Commissioning of the drive	76
7.2	Running the motor	76
7.2.1	Cable and motor insulation checks	77
7.3	Installation in it system	78
7.3.1	Frames MR4 to MR6.....	78
7.3.2	Frames MR7 and MR8.....	79
7.3.3	Frame MR9	80
7.4	Maintenance	82
8.	Technical data, Vacon 100.....	83
8.1	AC drive power ratings.....	83
8.1.1	Mains voltage 208-240 V	83
8.1.2	Mains voltage 380-500 V	84
8.1.3	Definitions of overloadability	85
8.1.4	Brake resistor ratings	86
8.2	Vacon 100 - technical data	88
8.2.1	Technical information on control connections	91
9.	Technical data, Vacon 100 FLOW	93
9.1	AC drive power ratings.....	93
9.1.1	Mains voltage 208-240 V	93
9.1.2	Mains voltage 380-500 V	94
9.1.3	Definitions of overloadability	95
9.2	Vacon 100 FLOW - technical data	96
9.2.1	Technical information on control connections	99

1. APPROVALS

Approvals granted to this Vacon product are listed on the following pages.

1.1 EC DECLARATION OF CONFORMITY

Find the EC Declaration of Conformity on the next page.

1.2 UL APPROVAL

cULus approval file number E171278.

1.3 C-TICK APPROVAL

C-tick approval file number N16307.



EC DECLARATION OF CONFORMITY

We

Manufacturer's name: Vacon Oyj
Manufacturer's address: P.O.Box 25
Runsorintie 7
FIN-65381 Vaasa
Finland

hereby declare that the product

Product name: Vacon 100 AC drive
Model designation: Vacon 0100-3L-0003-5...0310-5
Vacon 0100-3L-0003-2...0310-2

has been designed and manufactured in accordance with the following standards:

Safety: EN 61800-5-1 (2007)
EN 60204 -1 (2009) (as relevant)

EMC: EN61800-3 (2004)
EN61000-3-12

and conforms to the relevant safety provisions of the Low Voltage Directive (2006/95/EC) and EMC Directive 2004/108/EC.

It is ensured through internal measures and quality control that the product conforms at all times to the requirements of the current Directive and the relevant standards.

In Vaasa, 29th of February, 2012

A handwritten signature in black ink, appearing to read "Vesa Laisi".

Vesa Laisi
President

The year the CE marking was affixed: 2012

9226.emf



2. SAFETY

This manual contains clearly marked cautions and warnings which are intended for your personal safety and to avoid any unintentional damage to the product or connected appliances.

Please read the information included in cautions and warnings carefully.

The cautions and warnings are marked as follows:

Table 1. Warning signs

	= DANGER! Dangerous voltage
	= WARNING or CAUTION
	= Caution! Hot surface

2.1 DANGER



The **components of the power unit are live** when the drive is connected to mains potential. Coming into contact with this voltage is **extremely dangerous** and may cause death or severe injury.



The **motor terminals U, V, W and the brake resistor terminals are live** when the AC drive is connected to mains, even if the motor is not running.



After disconnecting the AC drive from the mains, **wait** 5 minutes before doing any work on the connections of the drive. Do not open the cover before this time has expired. After expiration of this time, use a measuring equipment to absolutely ensure that no voltage is present. **Always ensure absence of voltage before starting any electrical work!**



The control I/O-terminals are isolated from the mains potential. However, the **relay outputs and other I/O-terminals may have a dangerous control voltage** present even when the AC drive is disconnected from mains.



Before connecting the AC drive to mains make sure that the front and cable covers of the drive are closed.



During a coast stop (see Application Manual), the motor is still generating voltage to the drive. Therefore, do not touch the components of the AC drive before the motor has completely stopped. Wait 5 minutes before starting any work on the drive.

2.2 WARNINGS



The AC drive is meant for **fixed installations only**.



Do not perform any measurements when the AC drive is connected to the mains.



The **touch current** of the AC drives exceeds 3.5 mA AC. According to standard EN 61800-5-1, a **reinforced protective ground connection** must be ensured. See Chapter 2.3.



If the AC drive is used as a part of a machine, the **machine manufacturer is responsible** for providing the machine with a **supply disconnecting device** (EN 60204-1).



Only **spare parts** delivered by Vacon can be used.



At power-up, power brake or fault reset **the motor will start immediately** if the start signal is active, unless the pulse control for Start/Stop logic has been selected. Furthermore, the I/O functionalities (including start inputs) may change if parameters, applications or software are changed. Disconnect, therefore, the motor if an unexpected start can cause danger.



The **motor starts automatically** after automatic fault reset if the autoreset function is activated. See the Application Manual for more detailed information.



Prior to measurements on the motor or the motor cable, disconnect the motor cable from the AC drive.



Do not touch the components on the circuit boards. Static voltage discharge may damage the components.



Check that the **EMC level** of the AC drive corresponds to the requirements of your supply network. See Chapter 7.3.



In a domestic environment, this product may cause radio interference in which case supplementary mitigation measures may be required.



The AC drives are suitable for use on a circuit capable of delivering not more than 100,000 rms symmetrical amperes, 600 V maximum.

2.3 EARTHING AND EARTH FAULT PROTECTION



CAUTION!

The AC drive must always be earthed with an earthing conductor connected to the earthing terminal marked with \oplus .

The touch current of the drive exceeds 3.5 mA AC. According to EN 61800-5-1, one or more of the following conditions for the associated protective circuit shall be satisfied:

A fixed connection and

- a) the **protective earthing conductor** shall have a cross-sectional area of at least 10 mm² Cu or 16 mm² Al.

or

- b) an automatic disconnection of the supply in case of discontinuity of the **protective earthing conductor**. See Chapter 5.

or

- c) provision of an additional terminal for a second **protective earthing conductor** of the same cross-sectional area as the original **protective earthing conductor**.

Table 2. Protective earthing conductor cross-section

Cross-sectional area of phase conductors (S) [mm ²]	Minimum cross-sectional area of the corresponding protective earthing conductor [mm ²]
$S \leq 16$	S
$16 < S \leq 35$	16
$35 < S$	$S/2$

The values above are valid only if the protective earthing conductor is made of the same metal as the phase conductors. If this is not so, the cross-sectional area of the protective earthing conductor shall be determined in a manner which produces a conductance equivalent to that which results from the application of this table.

The cross-sectional area of every protective earthing conductor which does not form a part of the supply cable or cable enclosure shall, in any case, be not less than

- 2.5 mm² if mechanical protection is provided or
- 4 mm² if mechanical protection is not provided. For cord-connected equipment, provisions shall be made so that the protective earthing conductor in the cord shall, in the case of failure of the strain-relief mechanism, be the last conductor to be interrupted.

However, always follow the local regulations for the minimum size of the protective earthing conductor.

NOTE: Due to the high capacitive currents present in the AC drive, fault current protective switches may not function properly.



Do not perform any voltage withstand tests on any part of the AC drive. There is a certain procedure according to which the tests shall be performed. Ignoring this procedure may result in damaged product.

2.4 ELECTRO-MAGNETIC COMPATIBILITY (EMC)

The AC drives comply with IEC 61000-3-12 provided that the short-circuit power S_{SC} is greater than or equal to $120 R_{SCE}$ at the interface point between the user's supply and the public system. It is the responsibility of the installer or user of the equipment to ensure, by consultation with the distribution network operator if necessary, that the equipment is connected only to a supply with a short-circuit power S_{SC} greater than or equal to $120 R_{SCE}$.

2.5 COMPABILITY WITH RCDS



If a fault protection relay is used, it must be of at least type B, preferably B+ (according to EN 50178), with a trip level of 300 mA. This is for protection, not for touch protection in grounded systems.

3. RECEIPT OF DELIVERY

Check the correctness of delivery by comparing your order data to the drive information found on the package label. If the delivery does not correspond to your order, contact the supplier immediately. See Chapter 3.1.

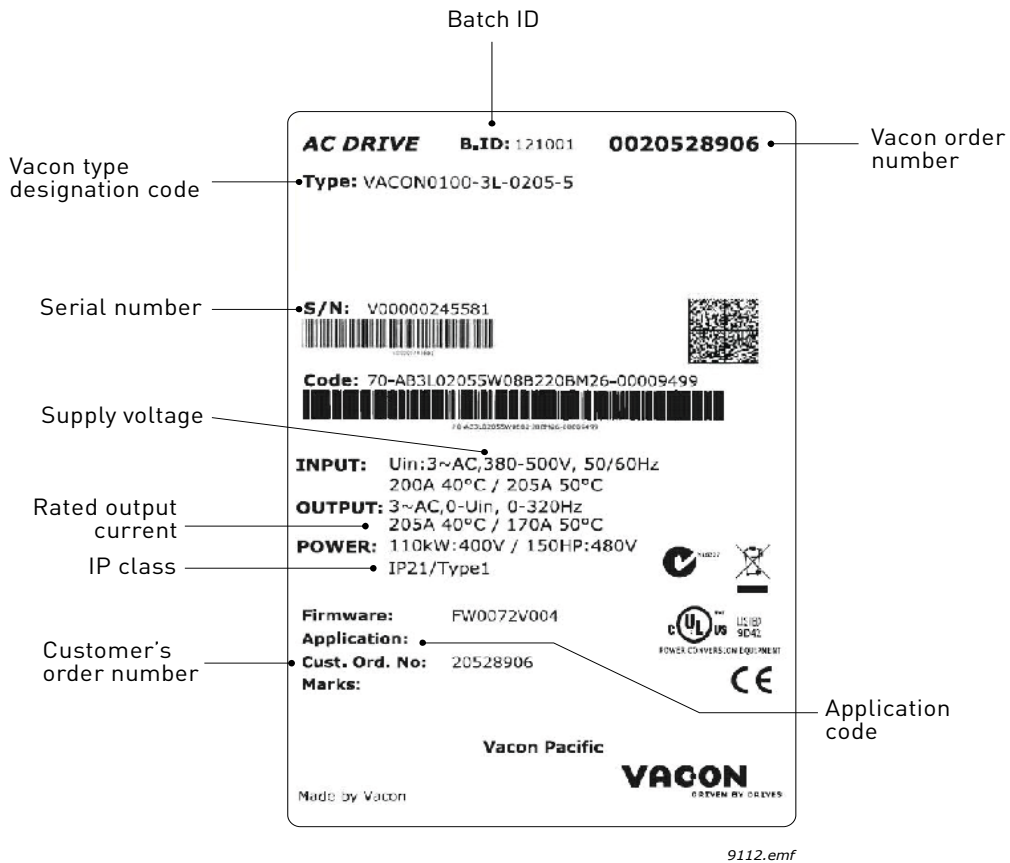

Figure 1. Vacon package label

3.1 TYPE DESIGNATION CODE

Vacon type designation code is formed of a nine-segment code and optional +codes. Each segment of the type designation code uniquely corresponds to the product and options you have ordered. The code is of the following format:

VACON0100-3L-0061-5 +xxxx +yyyy
VACON0100-3L-0061-FLOW +xxxx +yyyy

VACON

This segment is common for all products.

0100

Product range:

0100 = Vacon 100

3L

Input/Function:

3L = Three-phase input

0061

Drive rating in ampere; e.g. 0061 = 61 A

5

Supply voltage:

2 = 208-240 V

5 = 380-500 V

FLOW

Only for Vacon 100 FLOW drives

+xxxx +yyyy

Additional codes. (Several options possible)

Examples of additional codes:

+IP54

AC drive with IP protection class IP54

3.2 UNPACKING AND LIFTING THE AC DRIVE

The weights of the AC drives vary greatly according to the size. You may need to use a piece of special lifting equipment to move the drive from its package. Note the weights of each individual frame size in Table below.

Table 3. Frame weights

Frame	Weight, IP21/IP54 [kg]	Weight, IP00 [kg]	Weight, IP21/IP54 [lb.]	Weight, IP00 [lb.]
MR4	6.0		13.2	
MR5	10.0		22.0	
MR6	20.0		44.1	
MR7	37.5		82.7	
MR8	66.0	62.0	145.5	136.7
MR9	108.0	97.0	238.1	213.8

If you decide to use a piece of lifting equipment see picture below for recommendations to lift the drive.

3.2.1 LIFTING FRAMES MR8 AND MR9

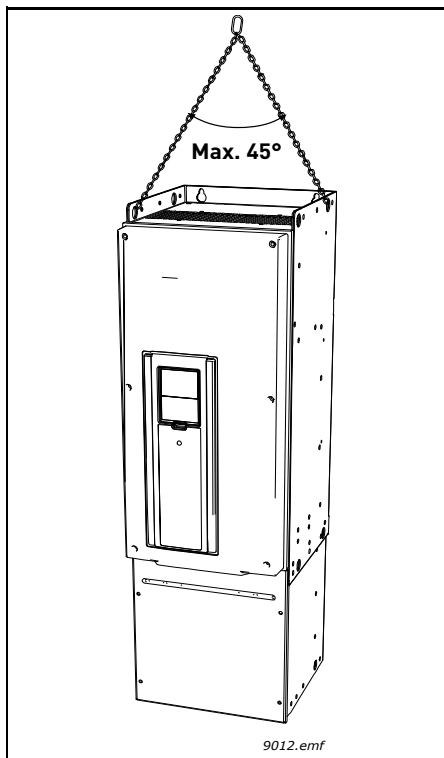

NOTE: First detach the drive from the pallet it has been bolted to.

NOTE: Place the lifting hooks symmetrically in at least two holes. The lifting device must be able to carry weight of the drive.

NOTE: The maximum allowed lifting angle is 45 degrees.

Figure 2. Lifting bigger frames

Vacon 100 AC drives have undergone scrupulous tests and quality checks at the factory before they are delivered to the customer. However, after unpacking the product, check that no signs of transport damages are to be found on the product and that the delivery is complete.

Should the drive have been damaged during the shipping, please contact primarily the cargo insurance company or the carrier.

3.3 ACCESSORIES

After having opened the transport package and lifted the drive out, check immediately that these various accessories were included in the delivery. The contents of the *accessories bag* differ by drive size and IP protections class:

3.3.1 FRAME MR4

Table 4. Contents of accessories bag, MR4

Item	Quantity	Purpose
M4x16 screw	11	Screws for power cable clamps (6), control cable clamps (3), grounding clamps (2)
M4x8 screw	1	Screw for optional grounding
M5x12 screw	1	Screw for drive external grounding
Control cable grounding lamella	3	Control cable grounding
EMC cable clamps, size M25	3	Clamping power cables
Grounding clamp	2	Power cable grounding
'Product modified' label	1	Information about modifications
IP21: Cable grommet	3	Cable run-through sealing
IP54: Cable grommet	6	Cable run-through sealing

3.3.2 FRAME MR5

Table 5. Contents of accessories bag, MR5

Item	Quantity	Purpose
M4x16 screw	13	Screws for power cable clamps (6), control cable clamps (3), grounding clamps (4)
M4x8 screw	1	Screw for optional grounding
M5x12 screw	1	Screw for drive external grounding
Control cable grounding lamella	3	Control cable grounding
EMC cable clamps, size M25	1	Clamping brake cable
EMC cable clamps, size M32	2	Clamping power cables
Grounding clamp	2	Power cable grounding
'Product modified' label	1	Information about modifications
IP21: Cable grommet, hole diameter 25.3 mm	1	Cable run-through sealing
IP54: Cable grommet, hole diameter 25.3 mm	4	Cable run-through sealing
Cable grommet, hole diameter 33.0 mm	2	Cable run-through sealing

NOTE! Dynamic braking and brake resistor is not supported in Vacon 100 FLOW.

3.3.3 FRAME MR6*Table 6. Contents of accessories bag, MR6*

Item	Quantity	Purpose
M4x20 screw	10	Screws for power cable clamps (6) and grounding clamps (4)
M4x16 screw	3	Screws for control cable clamps
M4x8 screw	1	Screw for optional grounding
M5x12 screw	1	Screw for drive external grounding
Control cable grounding lamella	3	Control cable grounding
EMC cable clamps, size M32	1	Clamping brake resistor cable
EMC cable clamps, size M40	2	Clamping power cables
Grounding clamp	2	Power cable grounding
'Product modified' label	1	Information about modifications
Cable grommet, hole diameter 33.0 mm	1	Cable run-through sealing
Cable grommet, hole diameter 40.3 mm	2	Cable run-through sealing
IP54: Cable grommet, hole diameter 25.3 mm	3	Cable run-through sealing

NOTE! Dynamic braking and brake resistor is not supported in Vacon 100 FLOW.

3.3.4 FRAME MR7*Table 7. Contents of accessories bag, MR7*

Item	Quantity	Purpose
M6x30 slotted nut	6	Nuts for power cable clamps
M4x16 screw	3	Screws for control cable clamps
M6x12 screw	1	Screw for drive external grounding
Control cable grounding lamella	3	Control cable grounding
EMC cable clamps, size M50	3	Clamping power cables
Grounding clamp	2	Power cable grounding
'Product modified' label	1	Information about modifications
Cable grommet, hole diameter 50.3 mm	3	Cable run-through sealing
IP54: Cable grommet, hole diameter 25.3 mm	3	Cable run-through sealing

3.3.5 FRAME MR8*Table 8. Contents of accessories bag, MR8*

Item	Quantity	Purpose
M4x16 screw	3	Screws for control cable clamps

Table 8. Contents of accessories bag, MR8

Item	Quantity	Purpose
Control cable grounding lamella	3	Control cable grounding
Cable lugs KP40	3	Clamping power cables
Cable insulator	11	Avoiding contact between cables
Cable grommet, hole diameter 25.3 mm	4	Control cable run-through sealing
IP00: Touch protection shield	1	Avoiding contact with live parts
IP00: M4x8 screw	2	Fixing the touch protection shield

3.3.6 FRAME MR9

Table 9. Contents of accessories bag, MR9

Item	Quantity	Purpose
M4x16 screw	3	Screws for control cable clamps
Control cable grounding lamella	3	Control cable grounding
Cable lugs KP40	5	Clamping power cables
Cable insulator	10	Avoiding contact between cables
Cable grommet, hole diameter 25.3 mm	4	Control cable run-through sealing
IP00: Touch protection shield	1	Avoiding contact with live parts
IP00: M4x8 screw	2	Fixing the touch protection shield

3.4 'PRODUCT MODIFIED' STICKER

In the Accessories bag included in the delivery you will find a silver *Product modified* sticker. The purpose of the sticker is to notify the service personnel about the modifications made in the AC drive. Attach the sticker on the side of the AC drive to avoid losing it. Should the AC drive be later modified mark the change on the sticker.

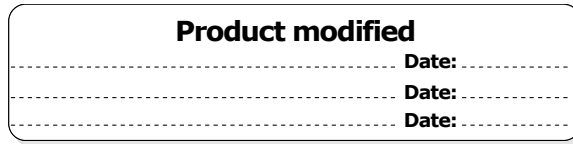

9004.emf

Figure 3. 'Product modified' sticker

3.5 DISPOSAL

	<p>When the device reaches the end of its operating life do not dispose of it as a part of standard household garbage. Main components of the product can be recycled, but some need to be fragmented to separate different types of materials and components that need to be treated as special waste from electrical and electronic components. To ensure environmentally sound and safe recycling treatment, the product can be taken to appropriate recycling center or returned to the manufacturer.</p> <p>Observe local and other applicable laws as they may mandate special treatment for specific components or special treatment may be ecologically sensible.</p>
--	---

4. MOUNTING

The AC drive must be mounted in vertical position on the wall or on the back plane of a cubicle. Ensure that the flatness variation shall not exceed 3 mm. Should the conditions of the mounting place require horizontal mounting, the functionalities within the given nominal values stated in Chapter 8 cannot be guaranteed.

The AC drive shall be fixed with the screws and other possible components included in the delivery.

4.1 DIMENSIONS

4.1.1 WALL MOUNT

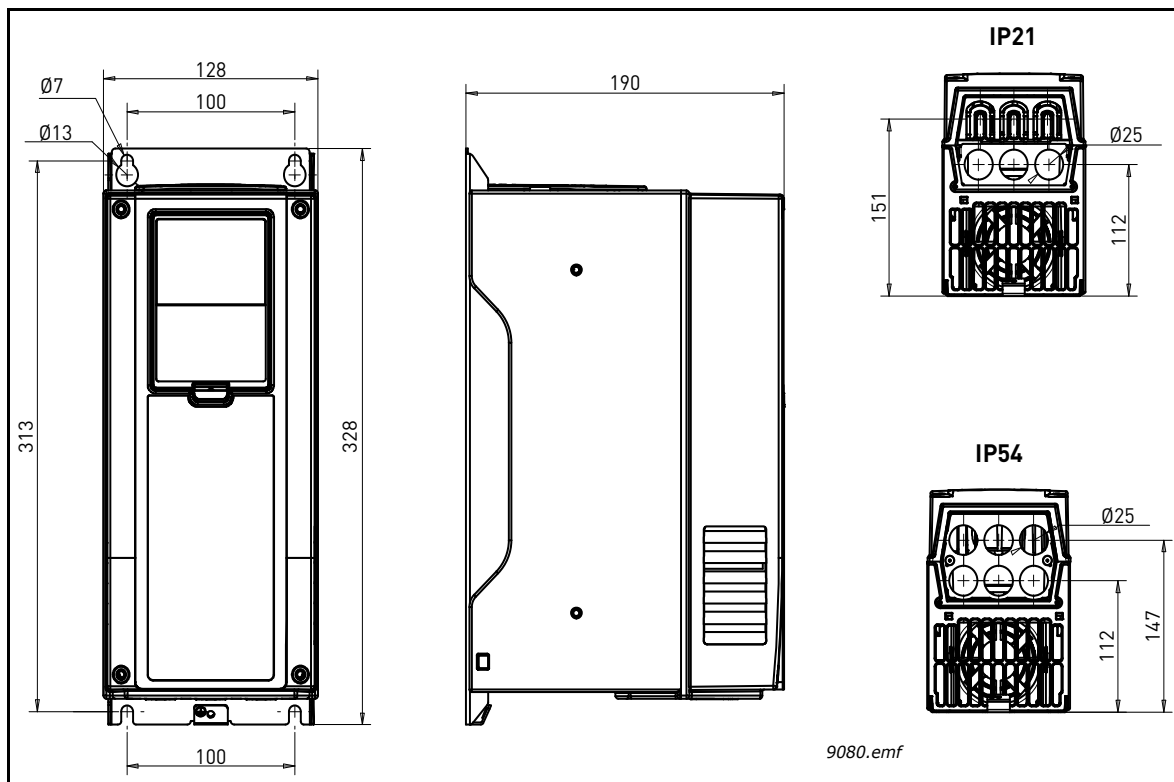

Figure 4. Vacon AC drive dimensions, MR4, wall mount

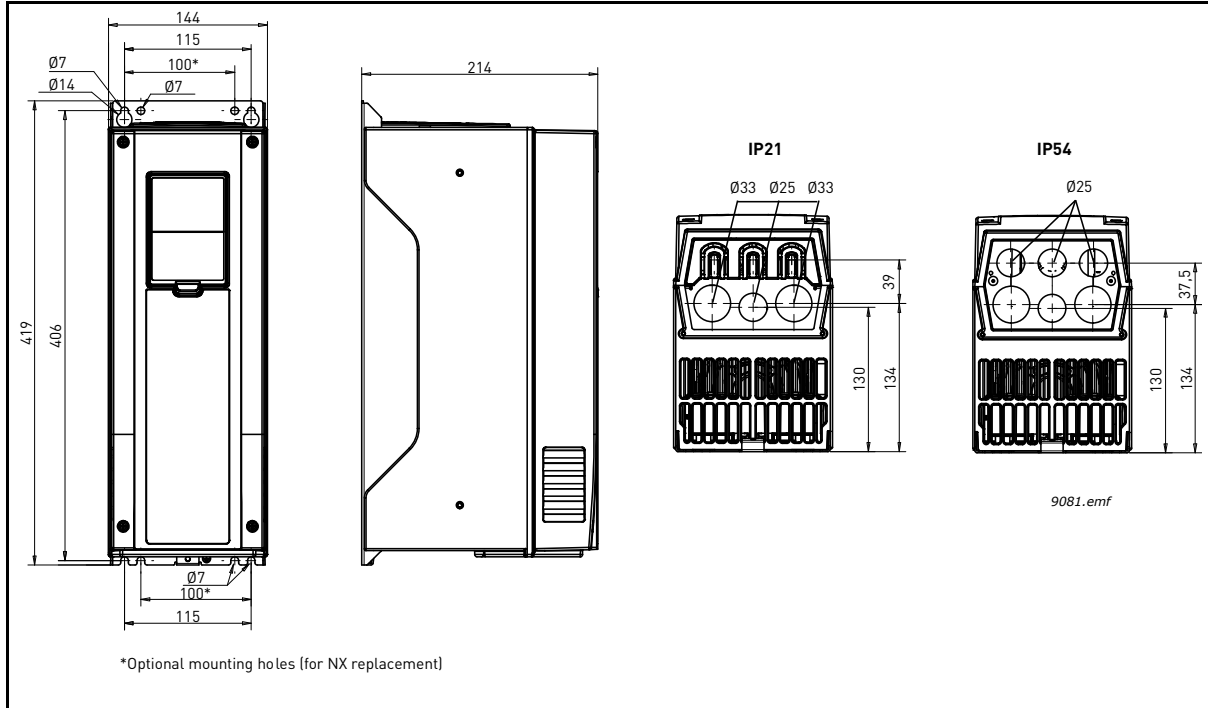

Figure 5. Vacon AC drive dimensions, MR5, wall mount

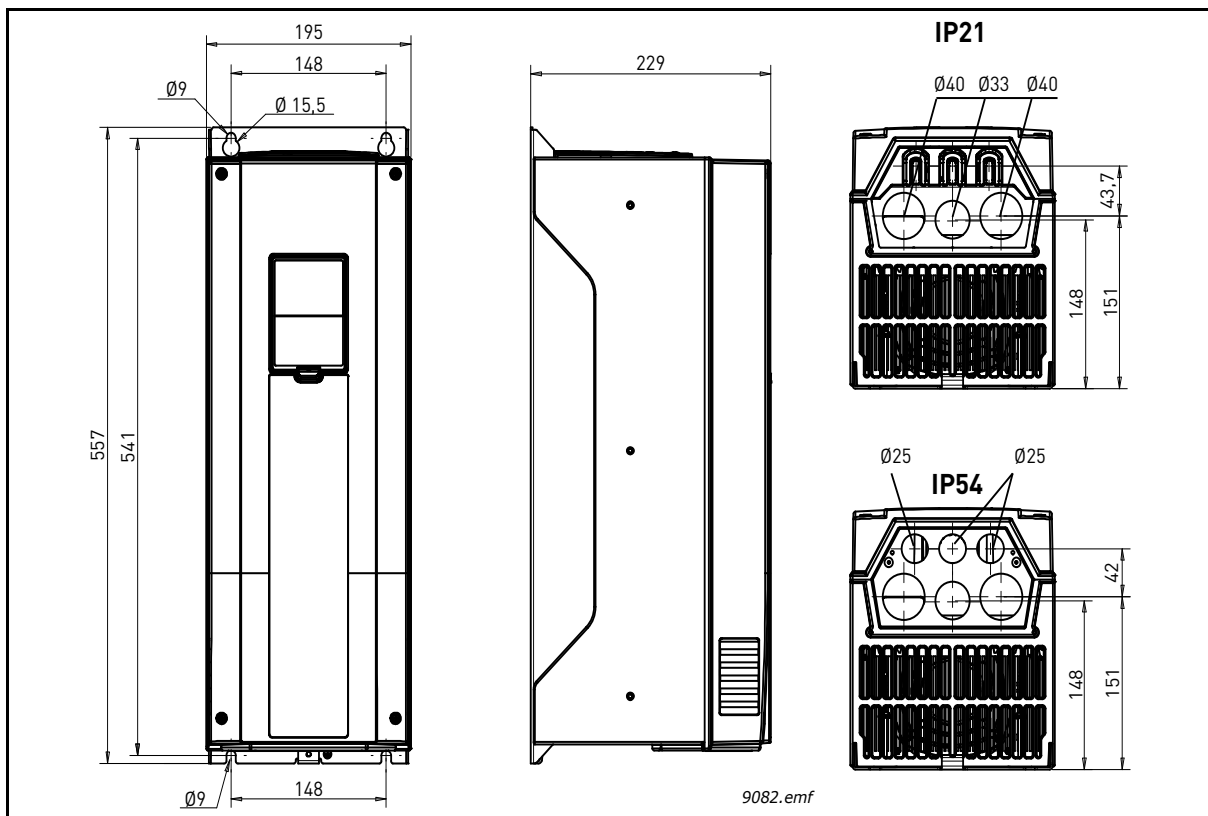

Figure 6. Vacon AC drive dimensions, MR6, wall mount

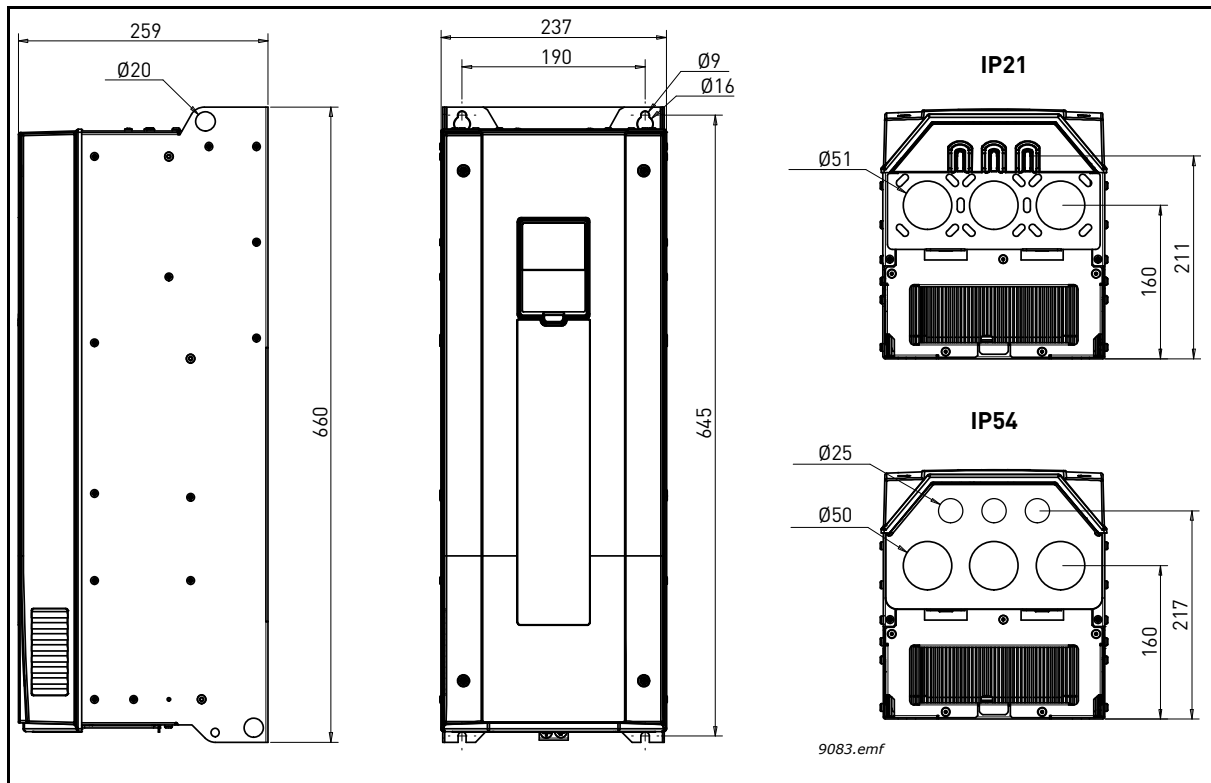

Figure 7. Vacon AC drive dimensions, MR7, wall mount

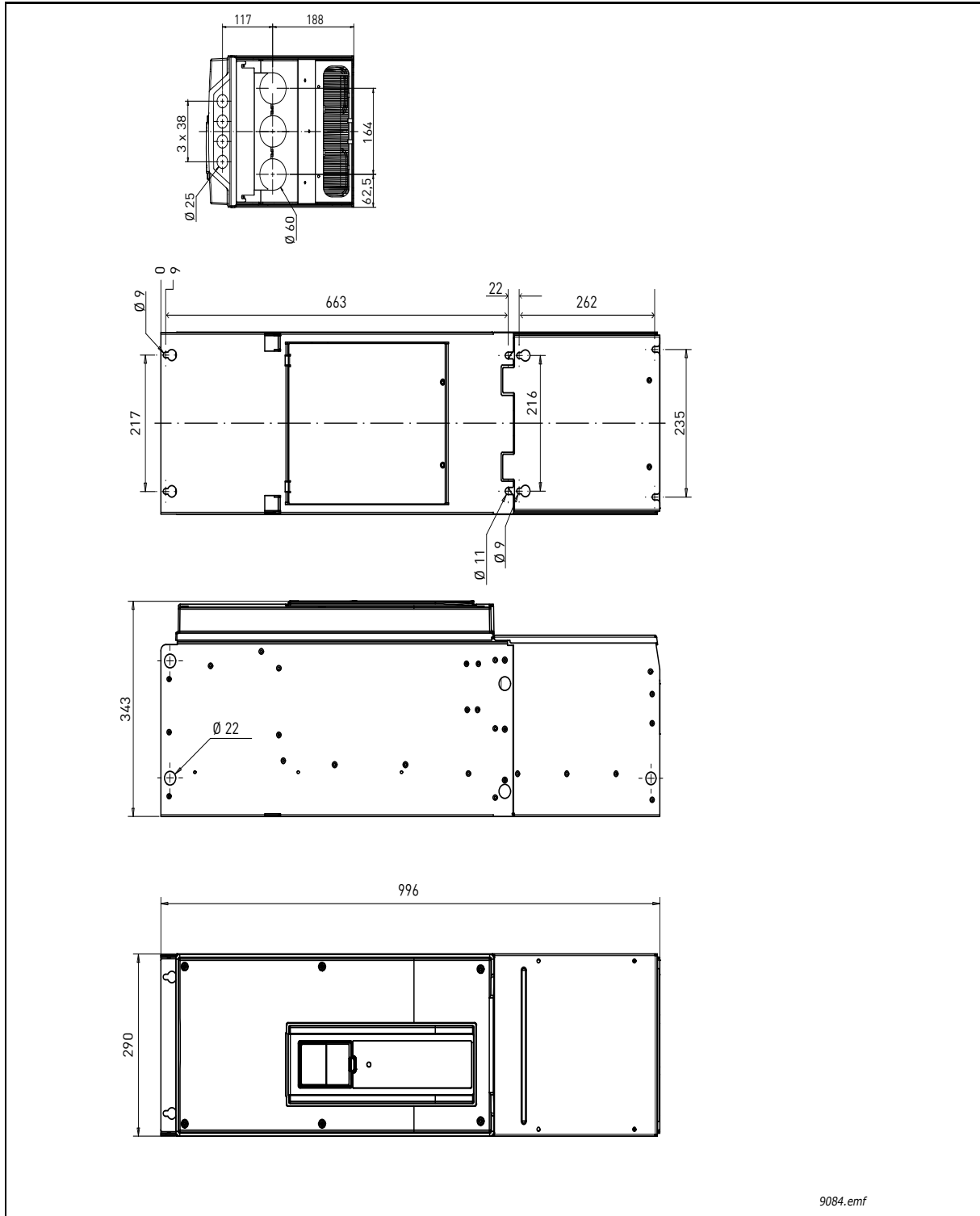

Figure 8. Vacon AC drive dimensions, MR8 IP21 and IP54

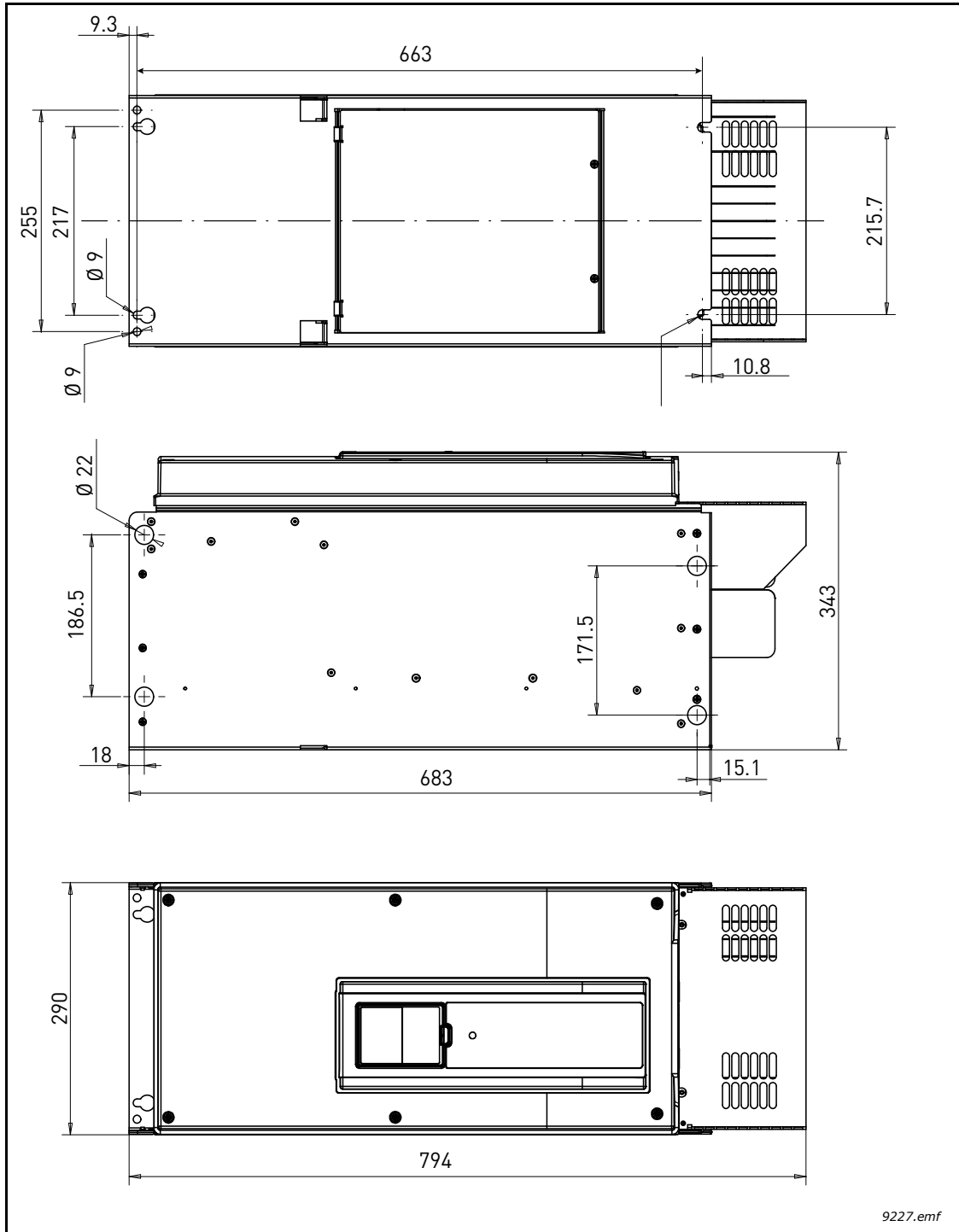

Figure 9. Vacon AC drive dimensions, MR8 IP00

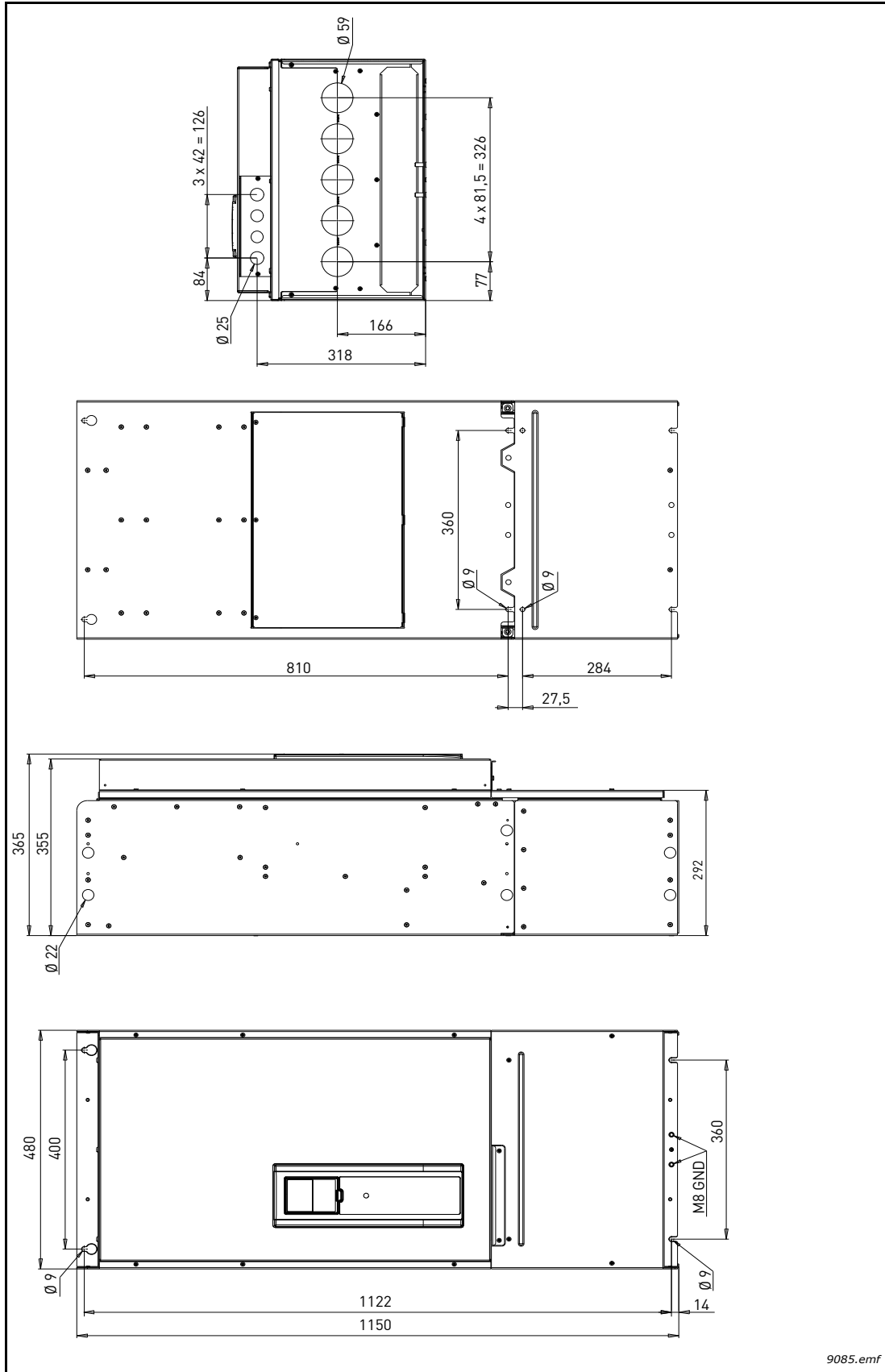

Figure 10. Vacon AC drive dimensions, MR9 IP21 and IP54

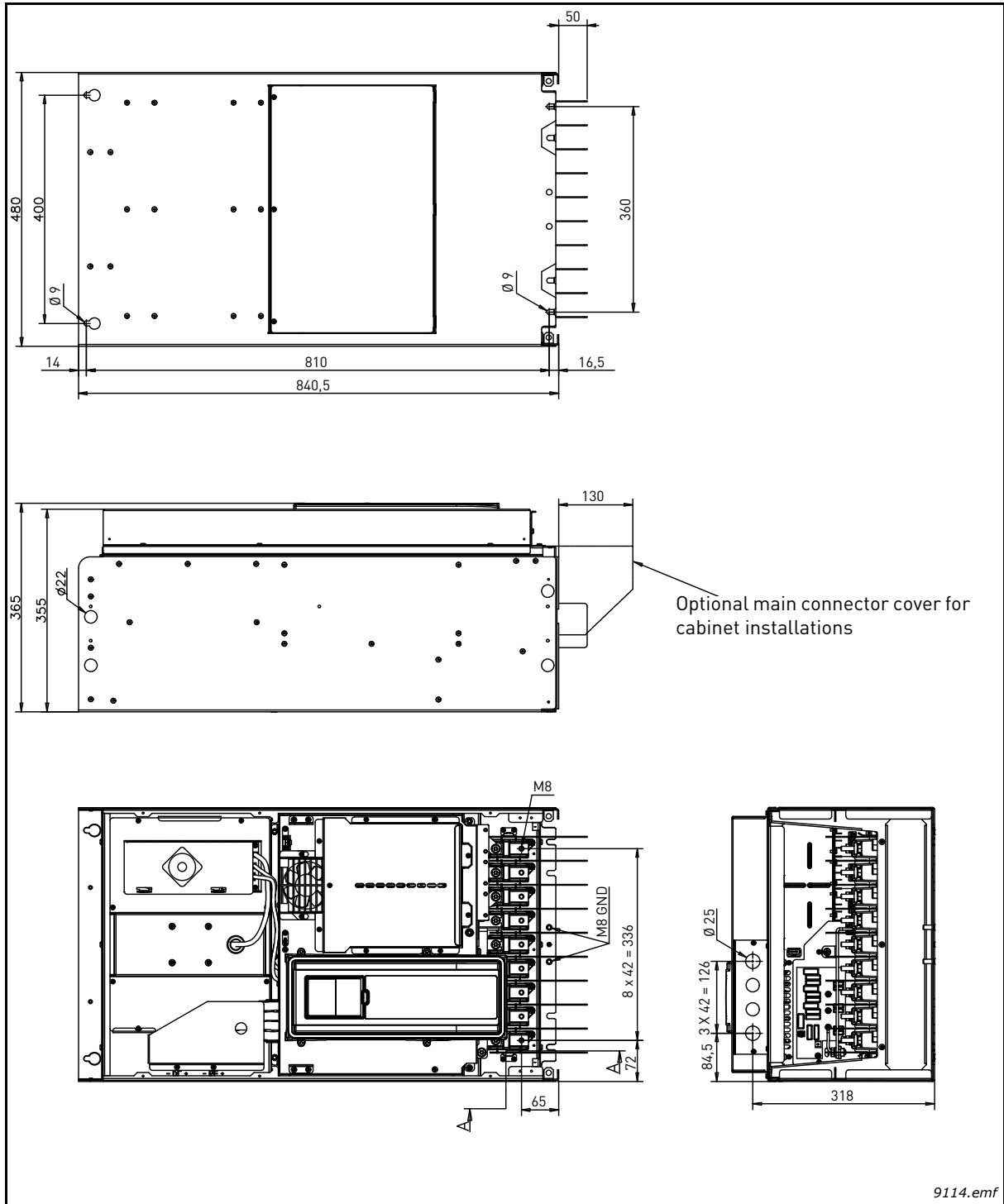

Figure 11. Vacon AC drive dimensions, MR9 IP00

4.1.2 FLANGE MOUNT

The AC drive can also be recessed into the cabinet wall or similar surface. A special *flange mount option* is available for this purpose. For an example of a flange-mounted drive, see Figure 12. Note the IP classes of different sections in figure below.

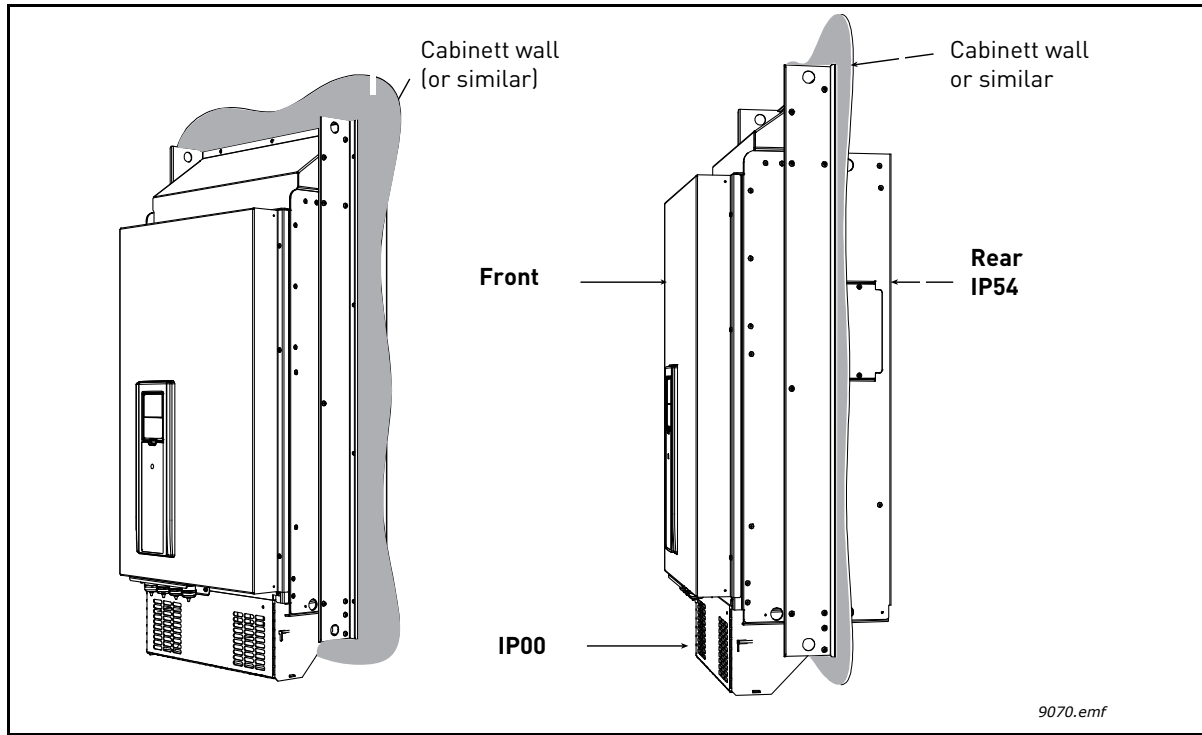

Figure 12. Example of flange mount (frame MR9)

4.1.2.1 FLANGE MOUNT - FRAMES MR4 TO MR9

Figure 19. presents the dimensions of the opening and drive outline with flange. Figures 13. - 18. present dimensions of the drives with the flange mount option.

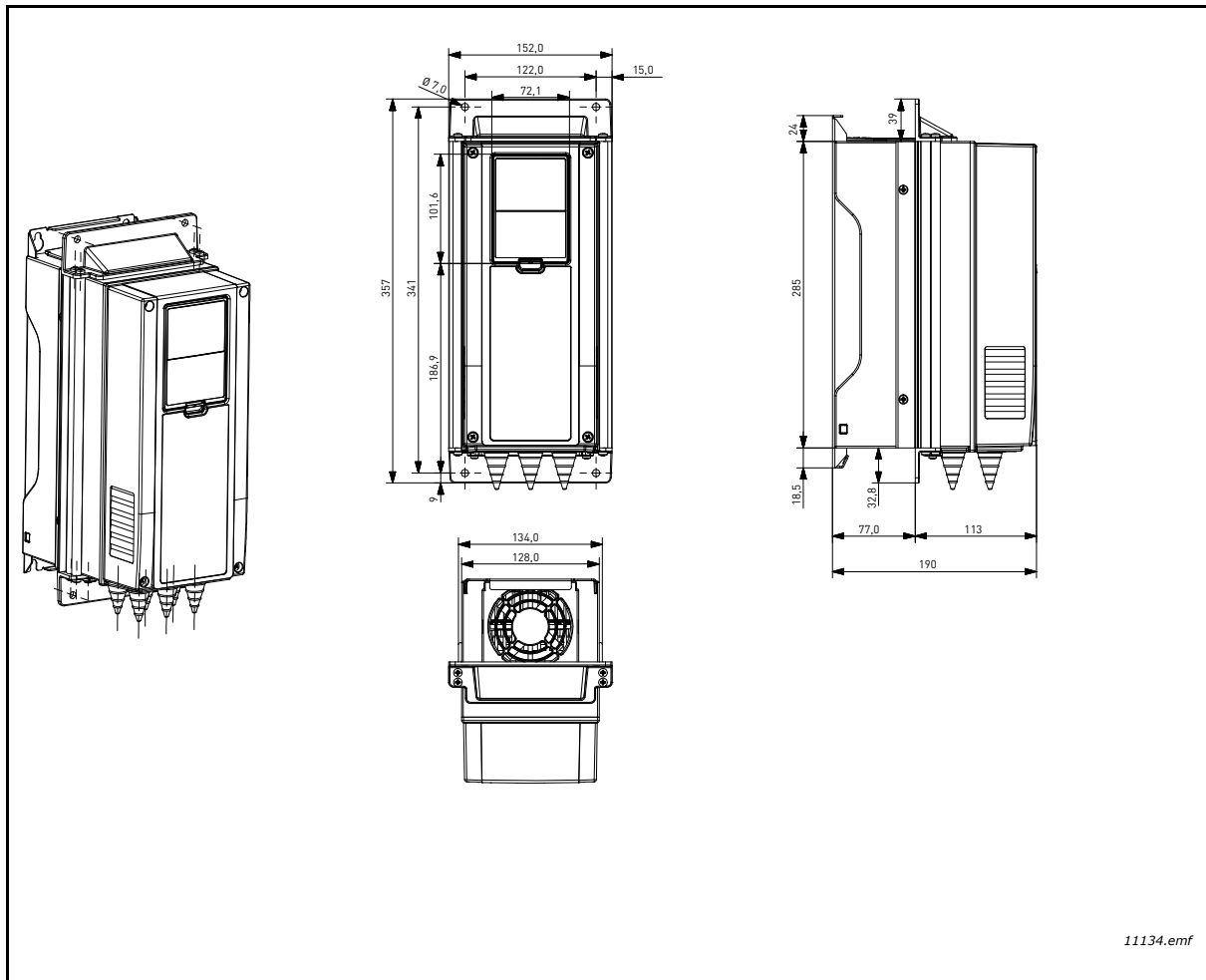
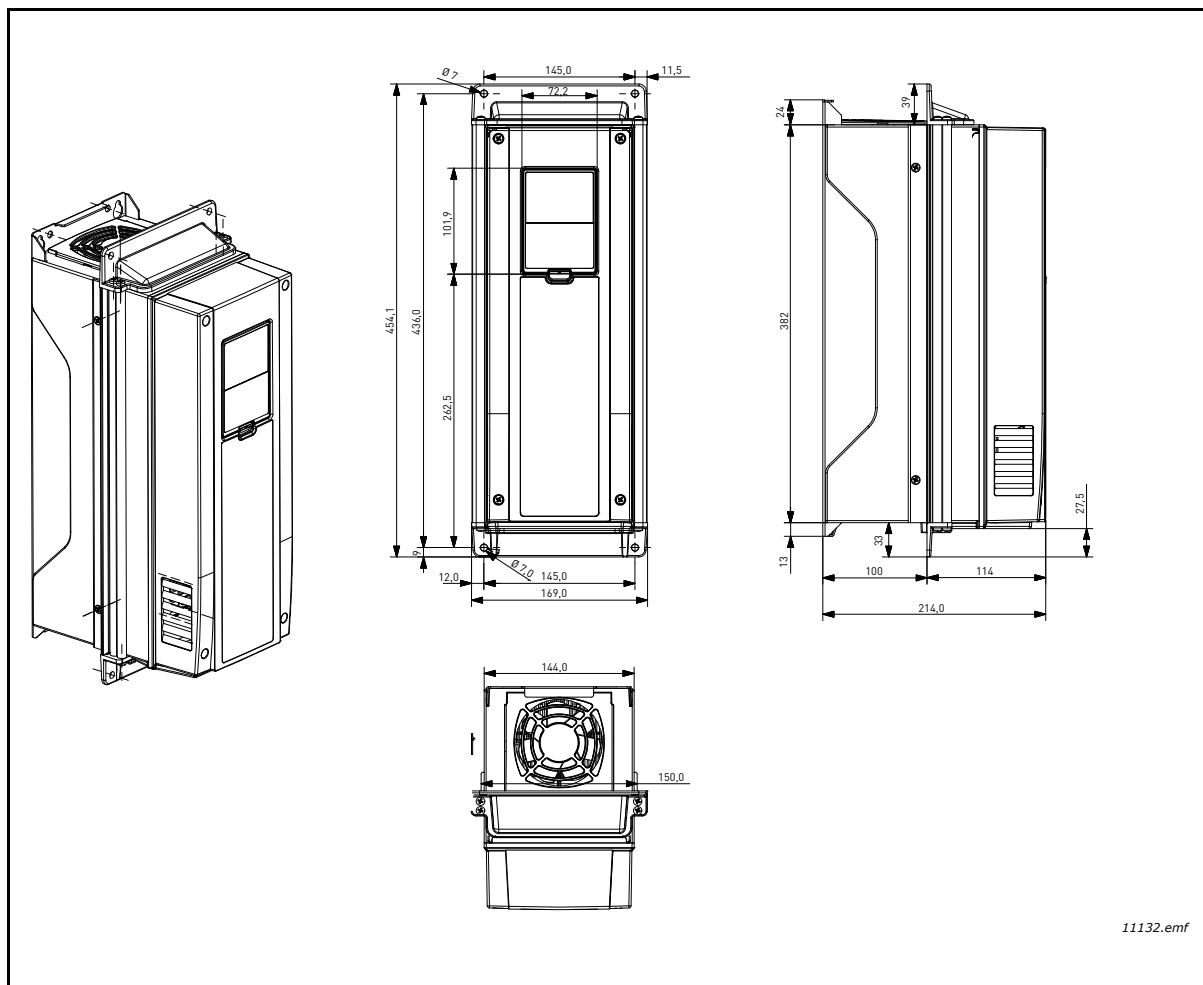
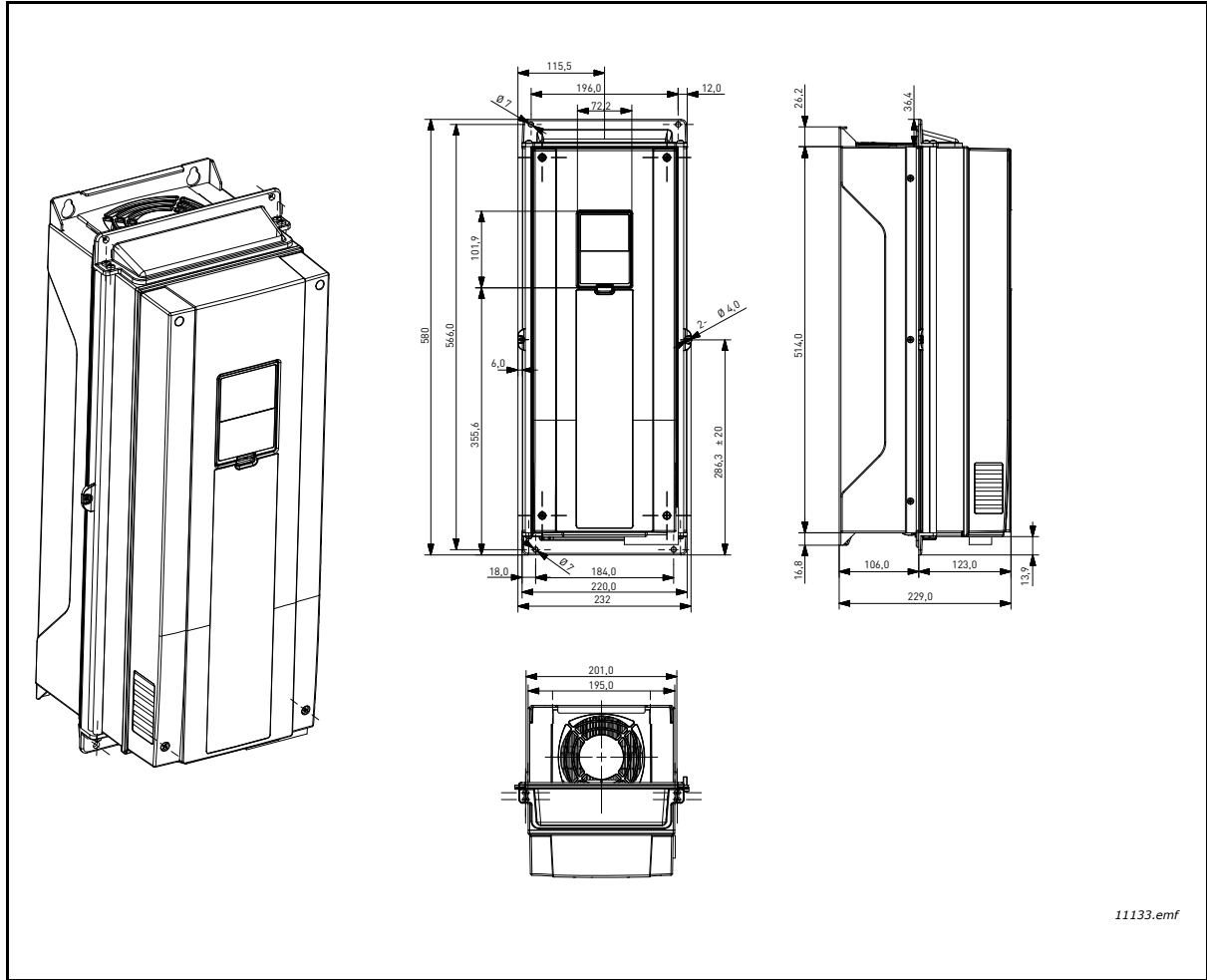

Figure 13. MR4, flange mount, dimensions



11132.emf

Figure 14. MR5, flange mount, dimensions



11133.emf

Figure 15. MR6, flange mount, dimensions

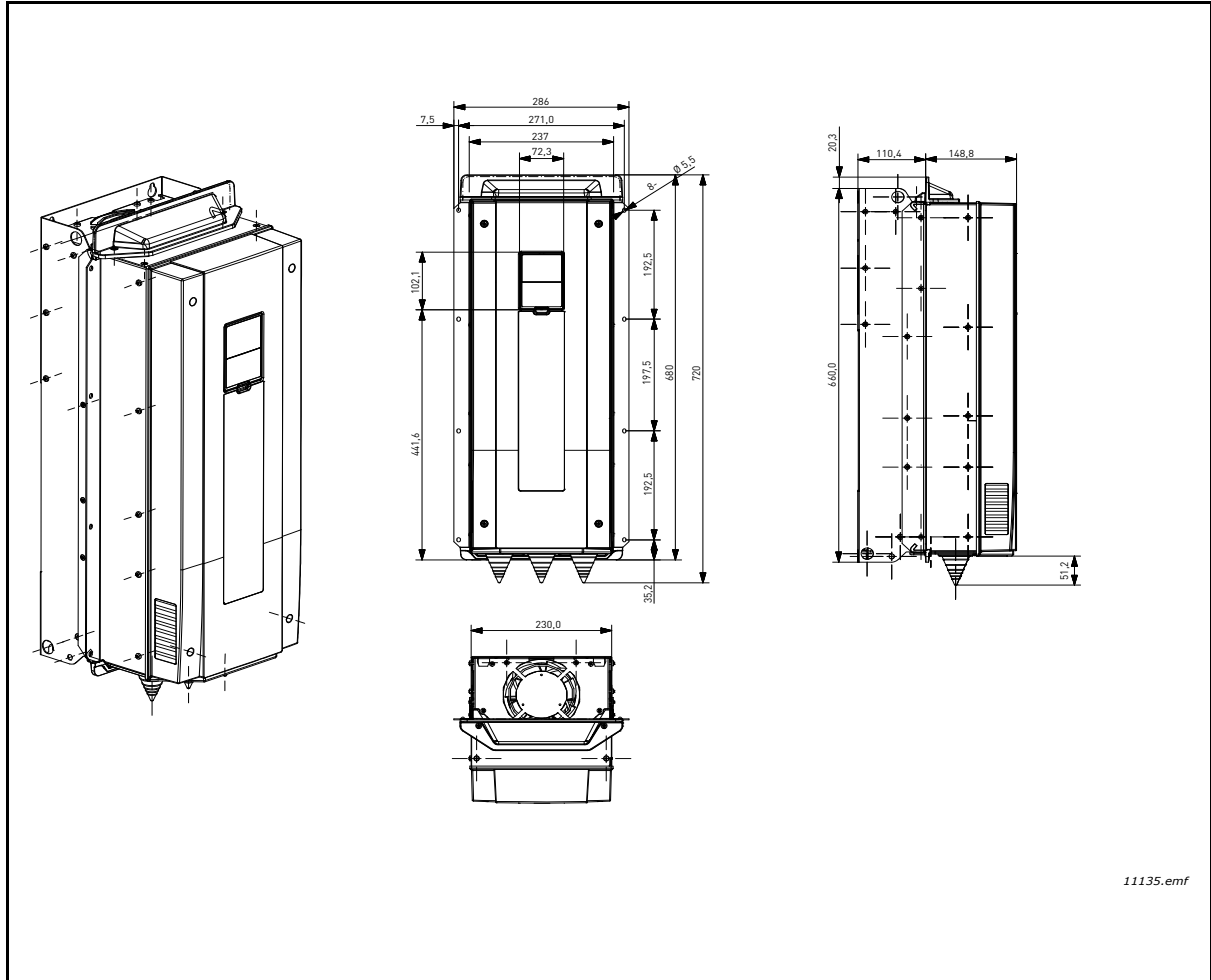

11135.emf

Figure 16. MR7, flange mount, dimensions

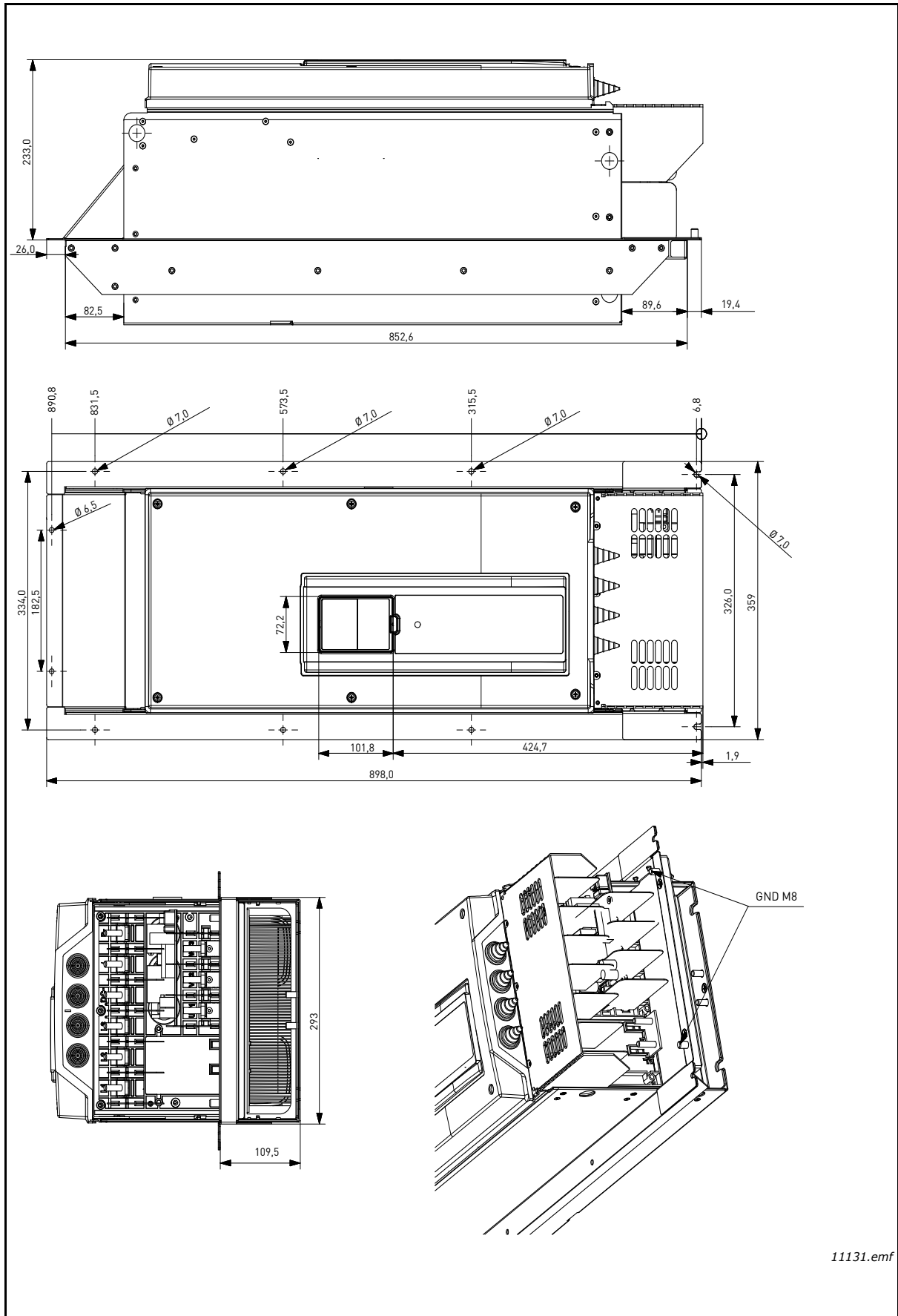

11131.emf

Figure 17. MR8, flange mount, dimensions

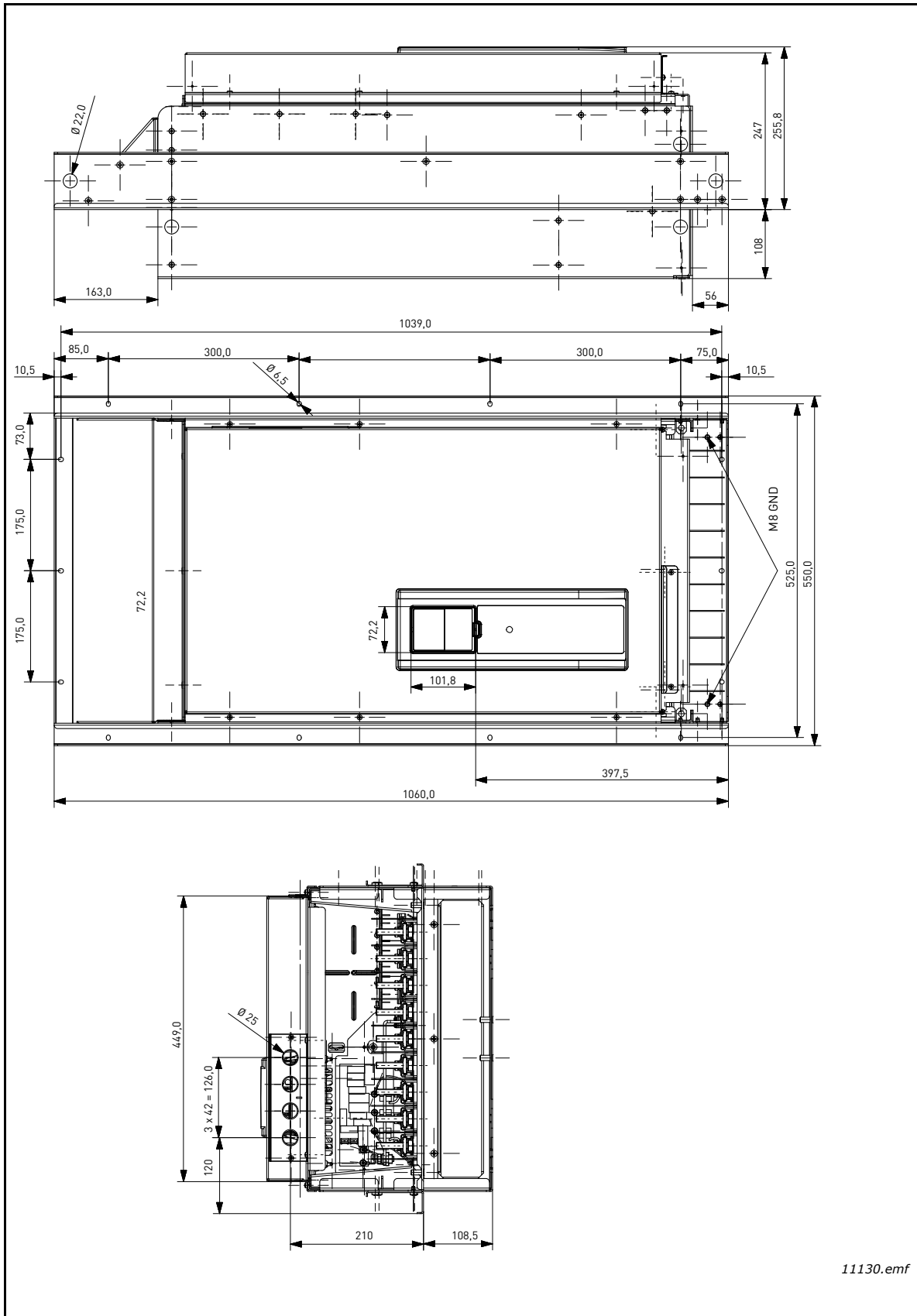

Figure 18. MR9, flange mount, dimensions

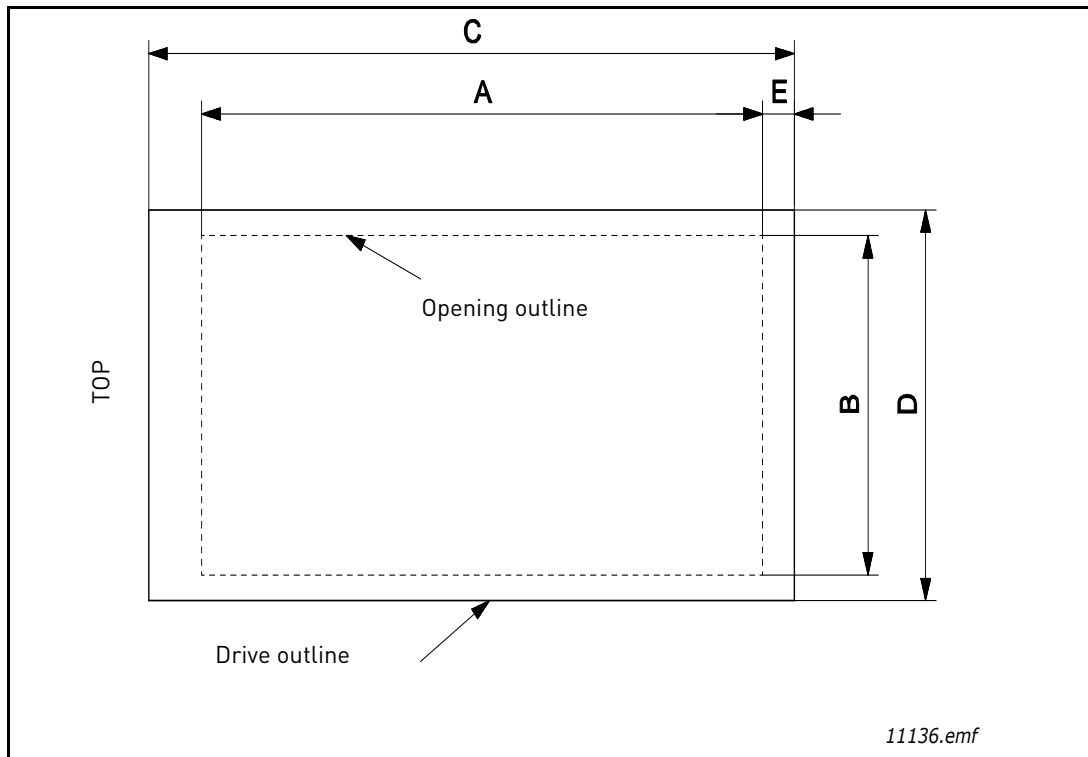

Figure 19. Flange mount cutout dimensions for MR4 to MR9

Table 10: Flange mount cutout dimensions for MR4 to MR9

Frame	A	B	C	D	E
MR4	315	137	357	152	24
MR5	408	152	454	169	23
MR6	541	203	580	220	23
MR7	655	240	680	286	13
MR8	859	298	898	359	18
MR9	975	485	1060	550	54

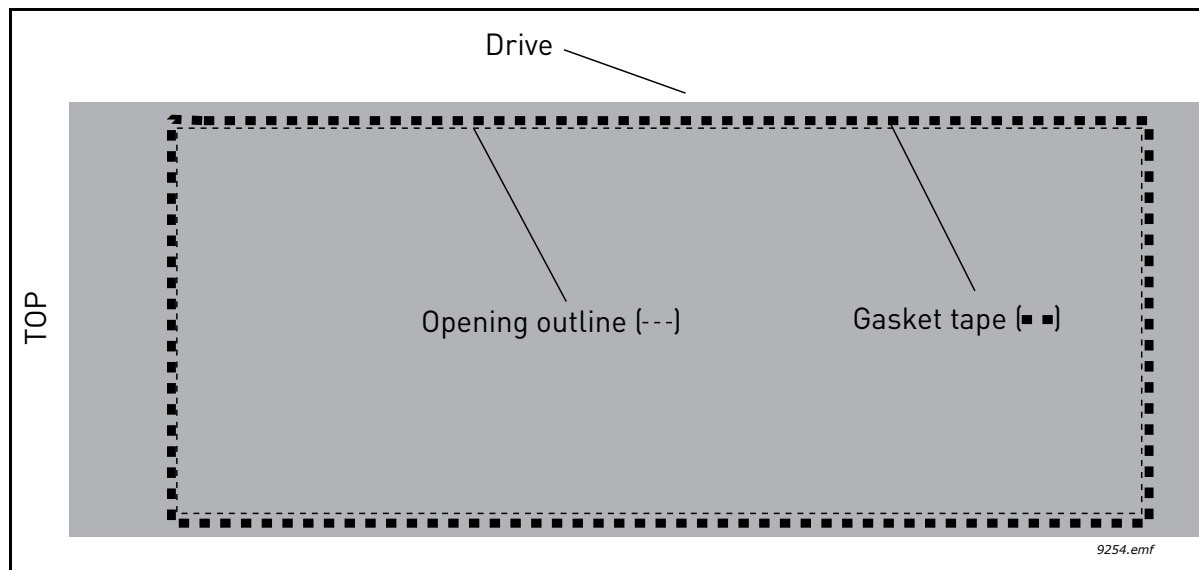

Figure 20. Sealing of the cutout for MR8 and MR9

4.2 COOLING

The AC drives produce heat in operation and are cooled down by air circulated by a fan. Enough free space shall therefore be left around the AC drive to ensure sufficient air circulation and cooling. Different acts of maintenance also require certain amount of free space.

Make sure that the temperature of the cooling air does not exceed the maximum ambient temperature of the drive.

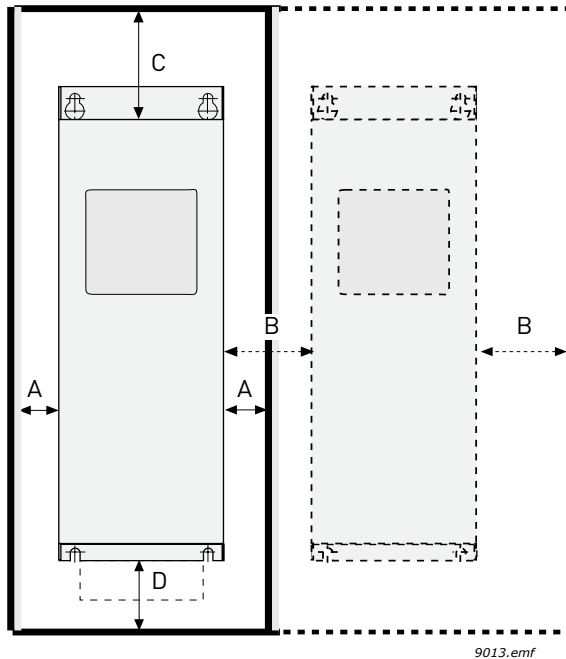

Table 11. Min. clearances around AC drive

Min clearance [mm]				
Type	A*	B*	C	D
MR4	20	20	100	50
MR5	20	20	120	60
MR6	20	20	160	80
MR7	20	20	250	100
MR8	20	20	300	150
MR9	20	20	350	200

*. Min clearances A and B for drives with IP54 enclosure is **0 mm**.

Figure 21. Installation space

- A** = clearance around the AC drive (see also B)
- B** = distance from one AC drive to another or distance to cabinet wall
- C** = free space above the AC drive
- D** = free space underneath the AC drive

Table 12. Required cooling air

Type	Cooling air required [m ³ /h]
MR4	45
MR5	75
MR6	190
MR7	185
MR8	335
MR9	621

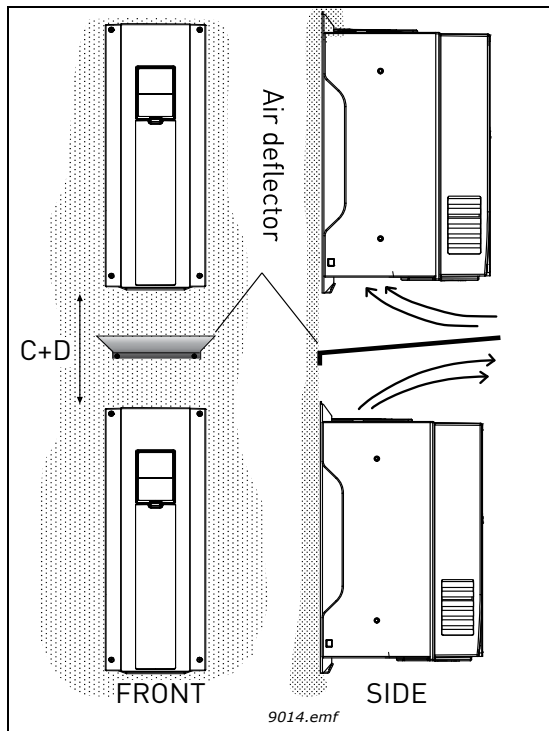

Note that if several units are mounted **above** each other the required free space equals $C + D$ (see Figure 22.). Moreover, the outlet air used for cooling by the lower unit must be directed away from the air intake of the upper unit by means of e.g. a piece of metal plate fixed to cabinet wall between the drives as shown in Figure 22. In addition, when planning the air circulation inside cabinets, recirculation of the air has to be avoided.

Figure 22. Installation space when drives are mounted on top of each other

5. POWER CABLING

The mains cables are connected to terminals L1, L2 and L3 and the motor cables to terminals marked with U, V and W. See principal connection diagram in Figure 23. See also Table 13 for the cable recommendations for different EMC levels.

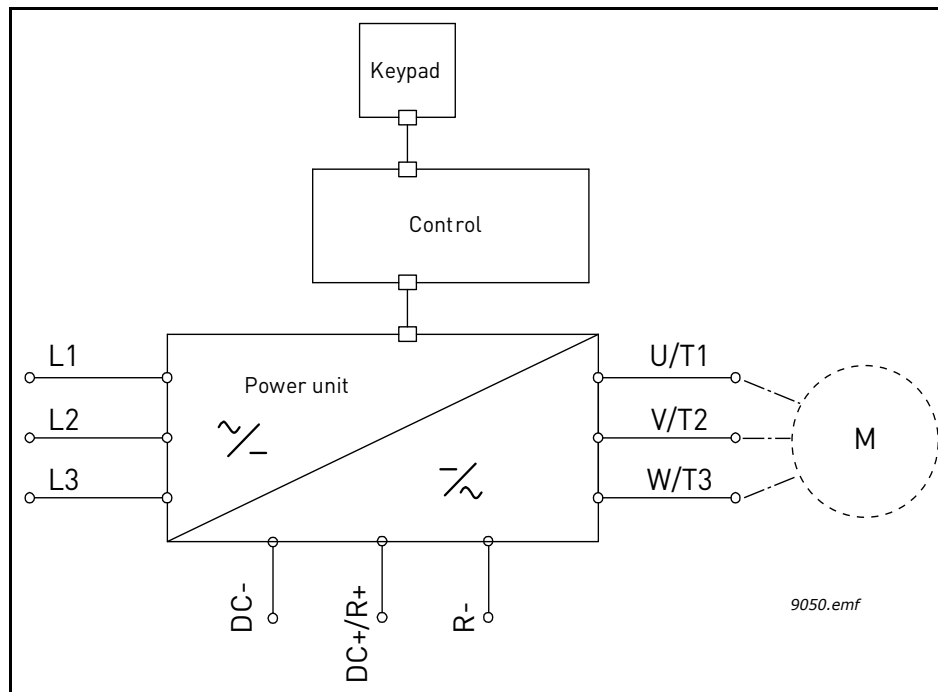

Figure 23. Principal connection diagram

Use cables with heat resistance of at least +70 °C. The cables and the fuses must be dimensioned according to the AC drive nominal OUTPUT current which you can find on the rating plate.

Table 13: Cable types required to meet standards

Cable type	EMC levels		
	1 st environment	2nd environment	
	Category C2	Category C3	Level C4
Mains cable	1	1	1
Motor cable	3*	2	2
Control cable	4	4	4

- 1 = Power cable intended for fixed installation and the specific mains voltage. Shielded cable not required. (MCMK or similar recommended).
- 2 = Symmetrical power cable equipped with concentric protection wire and intended for the specific mains voltage. (MCMK or similar recommended). See Figure 24.
- 3 = Symmetrical power cable equipped with compact low-impedance shield and intended for the specific mains voltage. [MCCMK, EMCCK or similar recommended; Recommended cable transfer impedance (1...30MHz) max. 100mohm/m]. See Figure 24.
*360° earthing of the shield with cable glands in **motor end** needed for EMC level C2.
- 4 = Screened cable equipped with compact low-impedance shield (JAMAK, SAB/ÖZCuY-0 or similar).

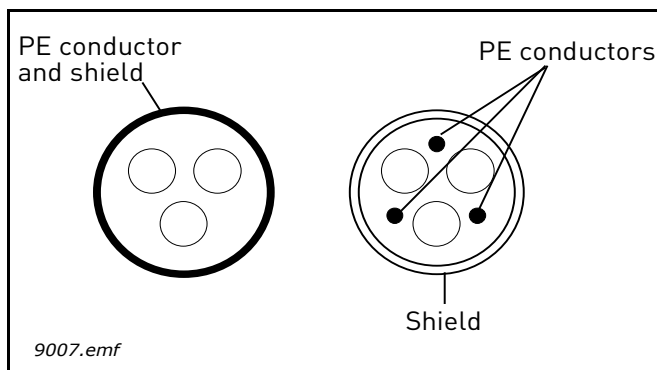

Figure 24.

NOTE: The EMC requirements are fulfilled at factory defaults of switching frequencies (all frames).

NOTE: If safety switch is connected the EMC protection shall be continuous over the whole cable installation.

5.1 UL STANDARDS ON CABLING

To meet the UL (Underwriters Laboratories) regulations, use a UL-approved copper cable with a minimum heat-resistance +60/75 °C. Use Class 1 wire only.

The units are suitable for use on a circuit capable of delivering not more than 100,000 rms symmetrical amperes, 600 V maximum.

5.1.1 CABLE DIMENSIONING AND SELECTION

Table shows the minimum dimensions of the Cu/Al-cables and the corresponding fuse sizes. Recommended fuse types are gG/gL.

These instructions apply only to cases with one motor and one cable connection from the AC drive to the motor. In any other case, ask the factory for more information.

5.1.1.1 CABLE AND FUSE SIZES

The recommended fuse types are gG/gL (IEC 60269-1) or class T (UL & CSA). The fuse voltage rating should be selected according to the supply network. The final selection should be made according to local regulations, cable installation conditions and cable specification. Bigger fuses than what is recommended below shall not be used.

Check that the fuse operating time is less than 0.4 seconds. Operating time depends on used fuse type and impedance of the supply circuit. Consult the factory about faster fuses. The manufacturer offers recommendations also for high speed J (UL & CSA), aR (UL recognized, IEC 60269-4) and gS (IEC 60269-4) fuse ranges.

Table 14. Cable and fuse sizes for Vacon 100

Frame	Type	I _L [A]	Fuse (gG/gL) [A]	Mains, motor and brake resistor* cable Cu [mm ²]	Terminal cable size			
					Main terminal [mm ²]	Earth terminal [mm ²]		
MR4	0003 2—0004 2	3.7—4.8	6	3*1.5+1.5	1—6 solid	1—6		
	0003 5—0004 5	3.4—4.8			1—4 stranded			
	0006 2—0008 2	6.6—8.0			1—6 solid			
0005 5—0008 5	5.6—8.0	1—4 stranded						
MR5	0011 2—0012 2	11.0—12.5	10	3*2.5+2.5	1—6 solid	1—6		
	0009 5—0012 5	9.6—12.0			1—4 stranded			
	0018 2	18.0			20		3*6+6	1—10 Cu
0016 5	16.0							
0024 2	24.0	25	3*6+6	1—10 Cu		1—10		
0023 5	23.0							
MR6	0031 2	31.0	32	3*10+10	1—10 Cu	1—10		
	0031 5	31.0						
	0038 5	38.0			40		3*10+10	2.5—50 Cu/Al
0048 2	48.0	50	3*16+16 (Cu) 3*25+16 (Al)	2.5—50 Cu/Al		2.5—35		
0046 5	46.0							
MR7	0062 2	62.0	63	3*25+16 (Cu) 3*35+10 (Al)	2.5—50 Cu/Al	2.5—35		
	0061 5	61.0						
	0075 2	75,0			80		3*35+16 (Cu) 3*50+16 (Al)	6-70 mm ² Cu/Al
0072 5	72,0							
0088 2	88,0	100	3*35+16 (Cu) 3*70+21 (Al)	6-70 mm ² Cu/Al		6-70 mm ²		
0087 5	87,0							
0105 2	105,0			125	3*50+25 (Cu) 3*70+21 (Al)		6-70 mm ² Cu/Al	6-70 mm ²
0105 5								
0140 2	140,0	160	3*70+35 (Cu) 3*95+29 (Al)			Bolt size M8	Bolt size M8	
0140 5								
0170 2	170,0			200	3*95+50 (Cu) 3*150+41 (Al)	Bolt size M8		Bolt size M8
0170 5								
0205 2	205,0	250	3*120+70 (Cu) 3*185+57 (Al)			Bolt size M8	Bolt size M8	
0205 5								

Table 14. Cable and fuse sizes for Vacon 100

Frame	Type	I_L [A]	Fuse (gG/gL) [A]	Mains, motor and brake resistor* cable Cu [mm ²]	Terminal cable size	
					Main terminal [mm ²]	Earth terminal [mm ²]
MR9	0261 2	261,0	315	3*185+95 (Cu)	Bolt size M8	Bolt size M8
	0261 5			2*3*120+41 (Al)		
	0310 2	310,0	350	2*3*95+50 (Cu)	Bolt size M8	Bolt size M8
	0310 5			2*3*120+41 (Al)		

*. If you use a multi-conductor cable, **NOTE** that one of the conductors of the brake resistor cable remains unconnected. Use of single cable is also allowed provided that the minimum cable cross-sectional area given in this table is observed.

The cable dimensioning is based on the criteria of the International Standard **IEC60364-5-52**: Cables must be PVC-isolated; Max ambient temperature +30 °C, max temperature of cable surface +70 °C; Use only cables with concentric copper shield; Max number of parallel cables is 9.

When using cables in parallel, **NOTE HOWEVER** that the requirements of both the cross-sectional area and the max number of cables must be observed.

For important information on the requirements of the earthing conductor, see chapter Earthing and earth fault protection of the standard.

For the correction factors for each temperature, see International Standard **IEC60364-5-52**.

NOTE! Dynamic braking and brake resistor is not supported in Vacon 100 FLOW.

5.1.1.2 CABLE AND FUSE SIZES, NORTH AMERICA

The recommended fuse types are gG/gL (IEC 60269-1) or class T (UL & CSA). The fuse voltage rating should be selected according to the supply network. The final selection should be made according to local regulations, cable installation conditions and cable specification. Bigger fuses than what is recommended below shall not be used.

Check that the fuse operating time is less than 0.4 seconds. Operating time depends on used fuse type and impedance of the supply circuit. Consult the factory about faster fuses. Vacon offers recommendations also for high speed J (UL & CSA), aR (UL recognized, IEC 60269-4) and gS (IEC 60269-4) fuse ranges.

Table 15. Cable and fuse sizes for Vacon 100

Frame	Type	I_L [A]	Fuse (class T) [A]	Mains, motor, brake resistor* and ground cable, Cu	Terminal cable size	
					Main terminal	Earth terminal
MR4	0003 2 0003 5	3,7 3.4	6	AWG14	AWG24-AWG10	AWG17-AWG10
	0004 2 0004 5	4.8	6	AWG14	AWG24-AWG10	AWG17-AWG10
	0006 2 0005 5	6.6 5.6	10	AWG14	AWG24-AWG10	AWG17-AWG10
	0008 2 0008 5	8.0	10	AWG14	AWG24-AWG10	AWG17-AWG10
	0011 2 0009 5	11.0 9.6	15	AWG14	AWG24-AWG10	AWG17-AWG10
	0012 2 0012 5	12.5 12.0	20	AWG14	AWG24-AWG10	AWG17-AWG10
MR5	0018 2 0016 5	18.0 16.0	25	AWG10	AWG20-AWG5	AWG17-AWG8
	0024 2 0023 5	24.0 23.0	30	AWG10	AWG20-AWG5	AWG17-AWG8
	0031 2 0031 5	31.0	40	AWG8	AWG20-AWG5	AWG17-AWG8
MR6	0038 5	38.0	50	AWG4	AWG13-AWG0	AWG13-AWG2
	0048 2 0046 5	48.0 46.0	60	AWG4	AWG13-AWG0	AWG13-AWG2
	0062 2 0061 5**	62.0 61.0	80	AWG4	AWG13-AWG0	AWG13-AWG2
MR7	0075 2 0072 5	75,0 72,0	100	AWG2	AWG9-AWG2/0	AWG9-AWG2/0
	0088 2 0087 5	88,0 87,0	110	AWG1	AWG9-AWG2/0	AWG9-AWG2/0
	0105 2 0105 5	105,0	150	AWG1/0	AWG9-AWG2/0	AWG9-AWG2/0

Table 15. Cable and fuse sizes for Vacon 100

Frame	Type	I_L [A]	Fuse (class T) [A]	Mains, motor, brake resistor* and ground cable, Cu	Terminal cable size	
					Main terminal	Earth terminal
MR8	0140 2 0140 5	140,0	200	AWG3/0	AWG1-350 kcmil	AWG1-350 kcmil
	0170 2 0170 5	170,0	225	250 kcmil	AWG1-350 kcmil	AWG1-350 kcmil
	0205 2 0205 5	205,0	250	350 kcmil	AWG1-350 kcmil	AWG1-350 kcmil
MR9	0261 2 0261 5	261,0	350	2*250 kcmil	AWG1-350 kcmil	AWG1-350 kcmil
	0310 2 0310 5	310,0	400	2*350 kcmil	AWG1-350 kcmil	AWG1-350 kcmil

*. If you use a multi-conductor cable, **NOTE** that one of the conductors of the brake resistor cable remains unconnected. Use of single cable is also allowed provided that the minimum cable cross-sectional area given in this table is observed.

** The 500 V models require 90-degree wire to meet UL regulations

The cable dimensioning is based on the criteria of the Underwriters' Laboratories UL508C: Cables must be PVC-isolated; Max ambient temperature +30 °C, max temperature of cable surface +70 °C; Use only cables with concentric copper shield; Max number of parallel cables is 9.

When using cables in parallel, **NOTE HOWEVER** that the requirements of both the cross-sectional area and the max number of cables must be observed.

For important information on the requirements of the earthing conductor, see standard Underwriters' Laboratories UL508C. For the correction factors for each temperature, see the instructions of standard Underwriters' Laboratories UL508C.

NOTE! Dynamic braking and brake resistor is not supported in Vacon 100 FLOW.

5.2 BRAKE RESISTOR CABLES

Vacon 100 AC drives are equipped with terminals for an optional external brake resistor. These terminals are marked with **R+** and **R-** (MR4-MR6) or **DC+/R+** and **R-** (MR7 and bigger). The recommended sizes for the brake resistor cables are listed in tables on page 38 to 40.

	If you use a multi-conductor cable, NOTE that one of the conductors of the brake resistor cable remains unconnected! Cut off the remaining conductor in order to avoid contact with a conducting component.
---	--

See brake resistor ratings on page 81.

	Please notice, in MR7-9 drives, only drives with +DBIN in the type code has the brake chopper option installed for dynamic braking. MR4-6 always has brake chopper for dynamic braking as standard.
---	---

NOTE! Dynamic braking and brake resistor is not supported in Vacon 100 FLOW.

5.3 CABLE INSTALLATION

- Before starting, check that none of the components of the AC drive is live. Read carefully the warnings in Chapter 2.
- Place the motor cables sufficiently far from other cables
- Avoid placing the motor cables in long parallel lines with other cables.
- If the motor cables run in parallel with other cables note the minimum distances between the motor cables and other cables given in table below.

Distance between cables, [m]	Shielded cable, [m]
0.3	≤ 50
1.0	≤ 200

- The given distances also apply between the motor cables and signal cables of other systems.
- The maximum lengths of motor cables (shielded) are 100 m (MR4), 150 m (MR5 and MR6) and 200 m (MR7 to MR9).
- The motor cables should cross other cables at an angle of 90 degrees.
- If cable insulation checks are needed, see chapter Cable and motor insulation checks.

Start the cable installation according to the instructions below:

5.3.1 FRAMES MR4 TO MR7

1 Strip the motor, mains and brake resistor cables as advised below.

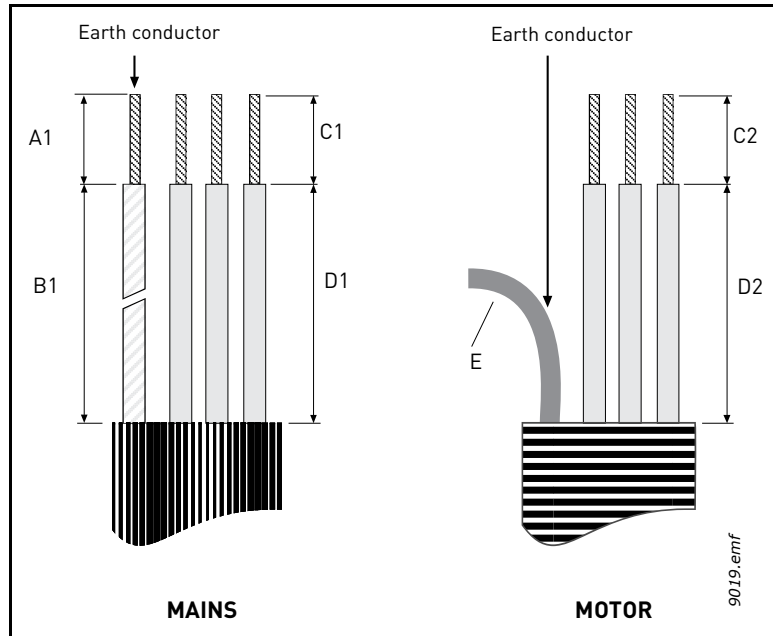

Figure 25. Stripping of cables

Table 16. Cables stripping lengths [mm]

Frame	A1	B1	C1	D1	C2	D2	E
MR4	15	35	10	20	7	35	Leave as short as possible
MR5	20	40	10	30	10	40	
MR6	20	90	15	60	15	60	
MR7	20	80	20	80	20	80	

NOTE! Dynamic braking and brake resistor is not supported in Vacon 100 FLOW.

2 Open the cover of the AC drive.

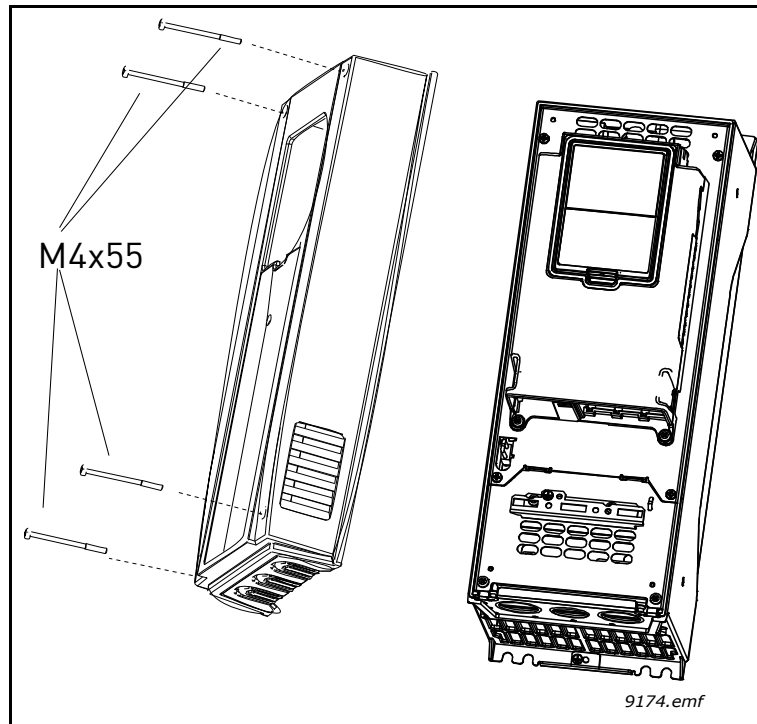

Figure 26. Opening cover

3 Remove the screws of the cable protection plate. Do not open the cover of the power unit!

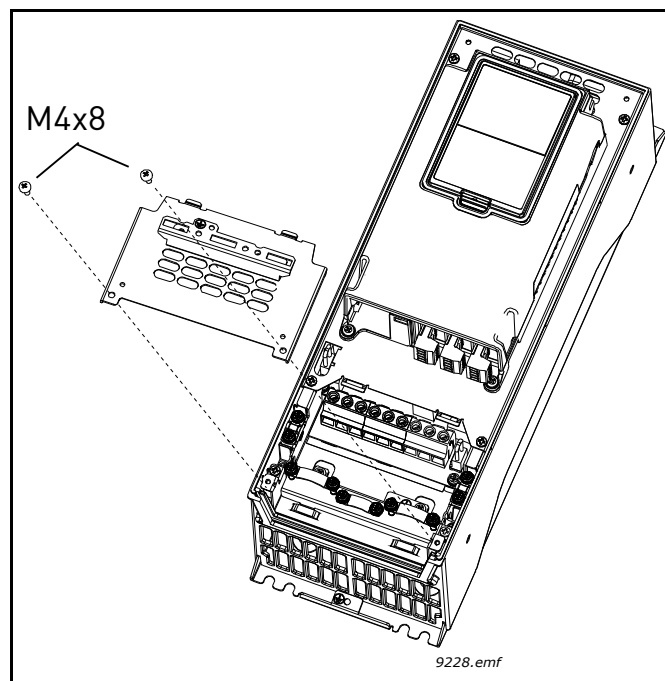

Figure 27. Removing screws

4

Insert the cable grommets (included in the delivery) in the openings of the cable entry plate (included) as shown in the picture (Picture EU version).

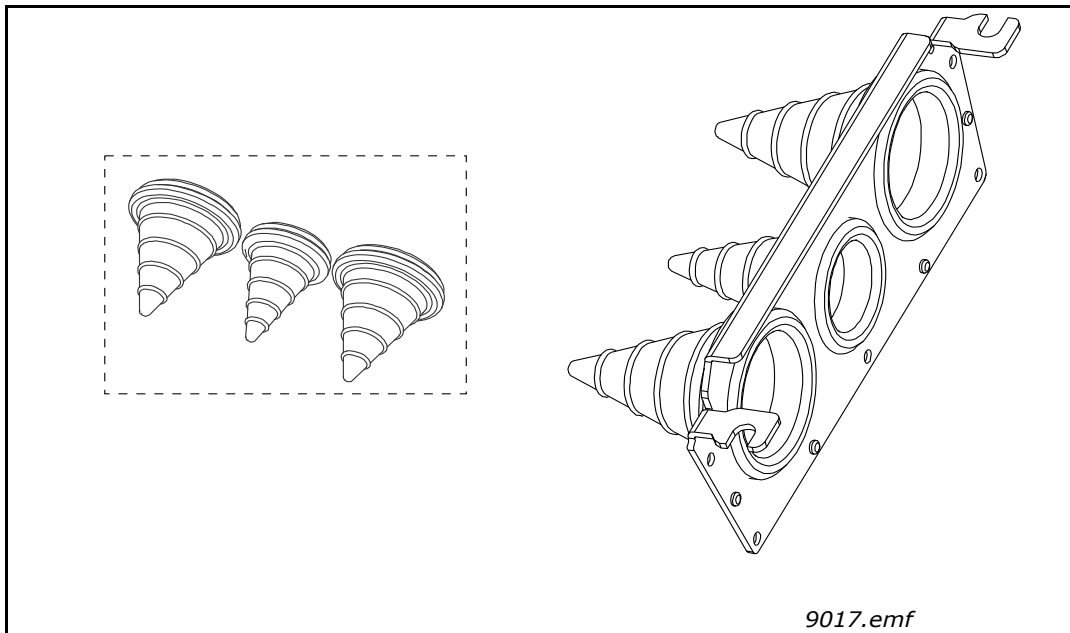

Figure 28. Examples of cable entry plates with grommets, IP21

5

- Insert the cables - supply cable, motor cable and optional brake cable - in the openings of the cable entry plate.
- Then cut the rubber grommets open to slide the cables through. Should the grommets fold in while inserting the cable, just draw the cable back a bit to straighten the grommets up.
- Do not cut the grommet openings wider than what is necessary for the cables you are using.

IMPORTANT NOTE FOR IP54 INSTALLATION:

To meet the requirements of the enclosure class IP54, the connection between the grommet and the cable must be tight. Therefore, lead the first bit of the cable out of the grommet **straight** before letting it bend. If this is not possible, the tightness of the connection must be ensured with insulation tape or a cable tie.

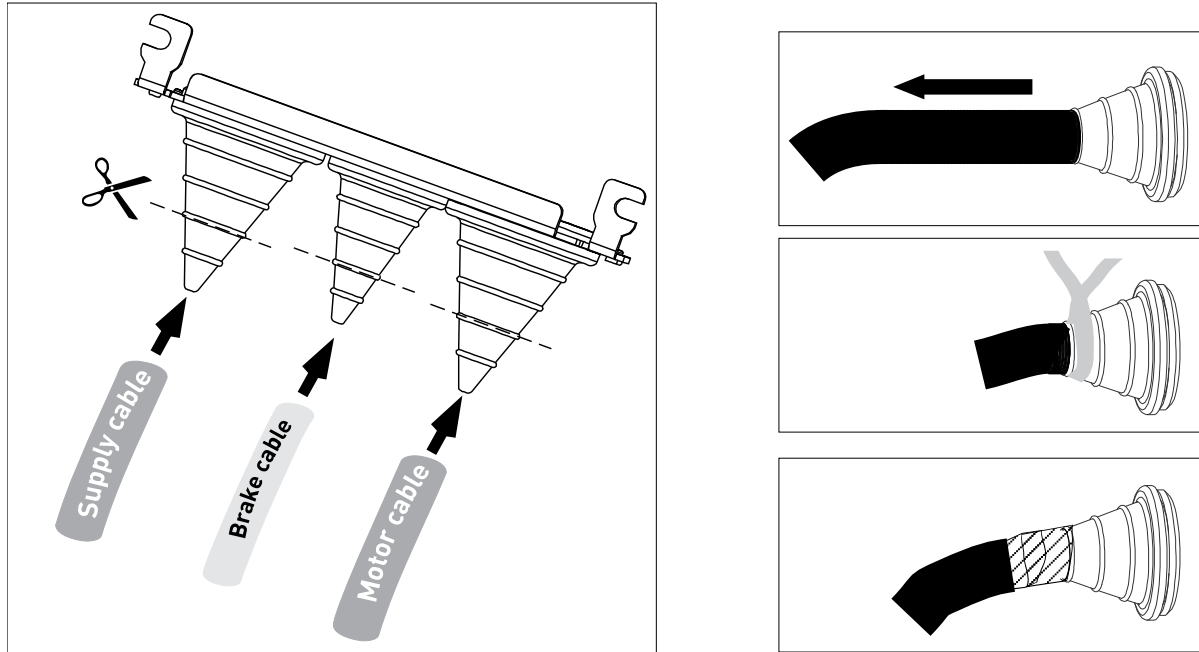

9071.emf

Figure 29. Grommet cutting and sealing

6 Detach the cable clamps and the grounding clamps (Figure 30) and place the cable entry plate with the cables in the groove on the AC drive frame (Figure 31).

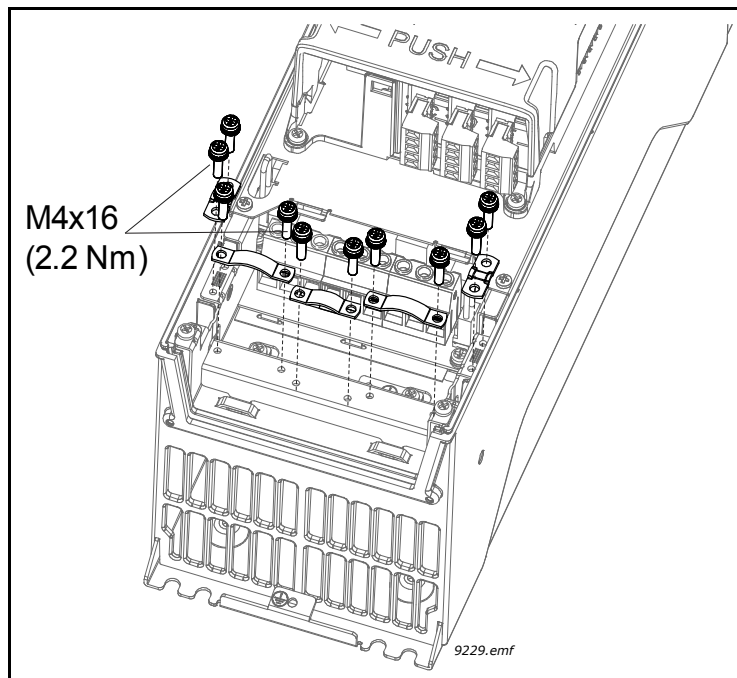

9229.emf

Figure 30. Detaching cable clamps

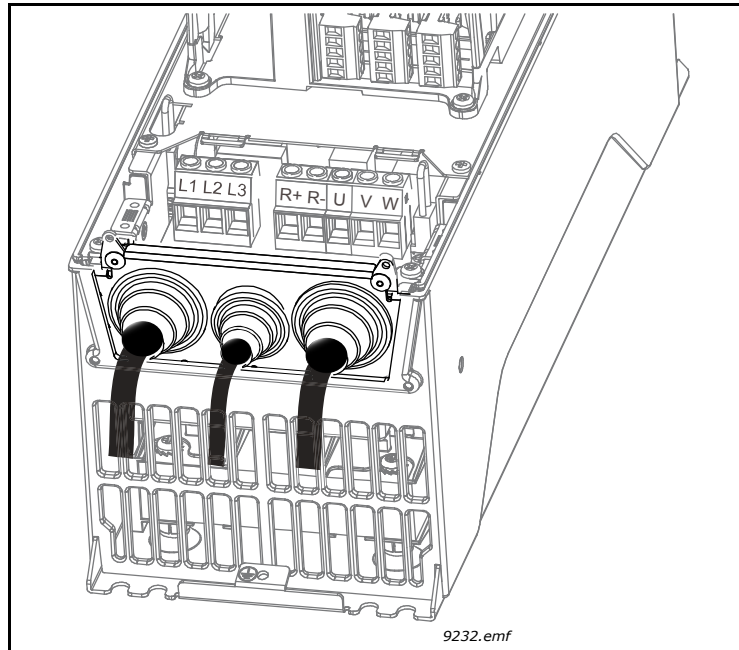

Figure 31. Cable entry plate and cables

7

Connect the stripped cables (see Figure 25 and Table) as shown in Figure 32.

- Expose the shield of all three cables in order to make a 360-degree connection with the cable clamp (1).
- Connect the (phase) conductors of the supply, brake and motor cables into their respective terminals (2).
- Form the rest of the cable shield of all three cables into “pigtails” and make a grounding connection with a clamp as shown in Figure 32 (3). Make the pigtails **just long enough** to reach and be fixed to the terminal - not longer.

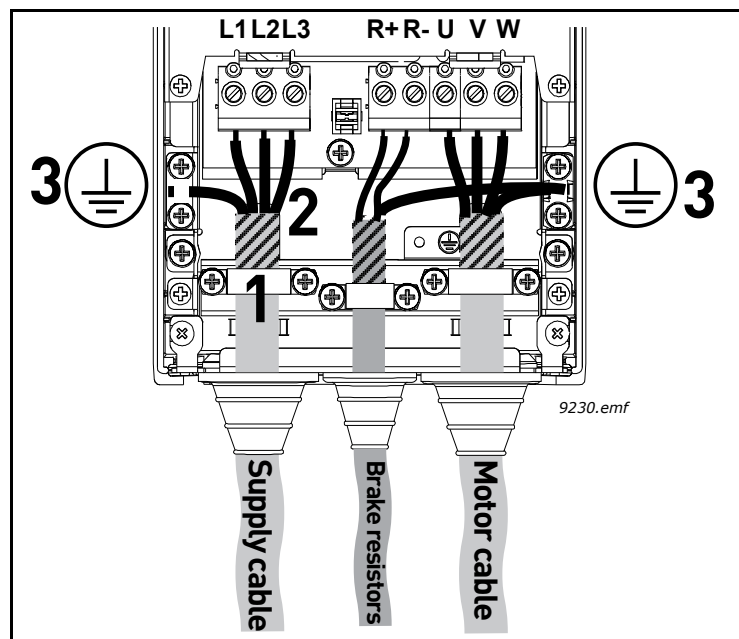



Figure 32. Cable connection

Tightening torques of cable terminals:

Table 17. Tightening torques of terminals

Frame	Type	Tightening torque [Nm]/[lb-in.] Power and motor terminals		Tightening torque [Nm]/[lb-in.] EMC grounding clamps		Tightening torque, [Nm]/[lb-in.] Grounding terminals	
		[Nm]	lb-in.	[Nm]	lb-in.	[Nm]	lb-in.
MR4	0003 2—0012 2 0003 5—0012 5	0.5—0.6	4.5—5.3	1.5	13.3	2.0	17.7
MR5	0018 2—0031 2 0016 5—0031 5	1.2—1.5	10.6—13.3	1.5	13.3	2.0	17.7
MR6	0048 2—0062 2 0038 5—0061 5	10	88.5	1.5	13.3	2.0	17.7
MR7	0075 2—0105 2 0072 5—0105 5	8/15*	70.8/132.8*	1.5	13.3	8/15*	70.8/132.8*

*. Cable clamping (Ouneva Pressure Terminal Connector)

8	<p>Check the connection of the earth cable to the motor and the AC drive terminals marked with .</p> <p>NOTE: Two protective conductors are required according to standard EN61800-5-1. See Figure 33 and chapter Earthing and earth fault protection. Use an M5 size screw and tighten it to 2.0 Nm (17.7 lb-in.).</p>
----------	--

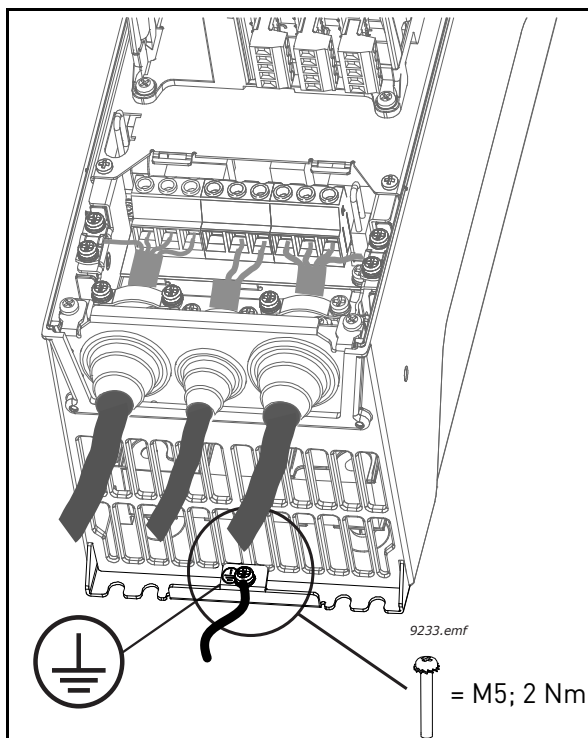
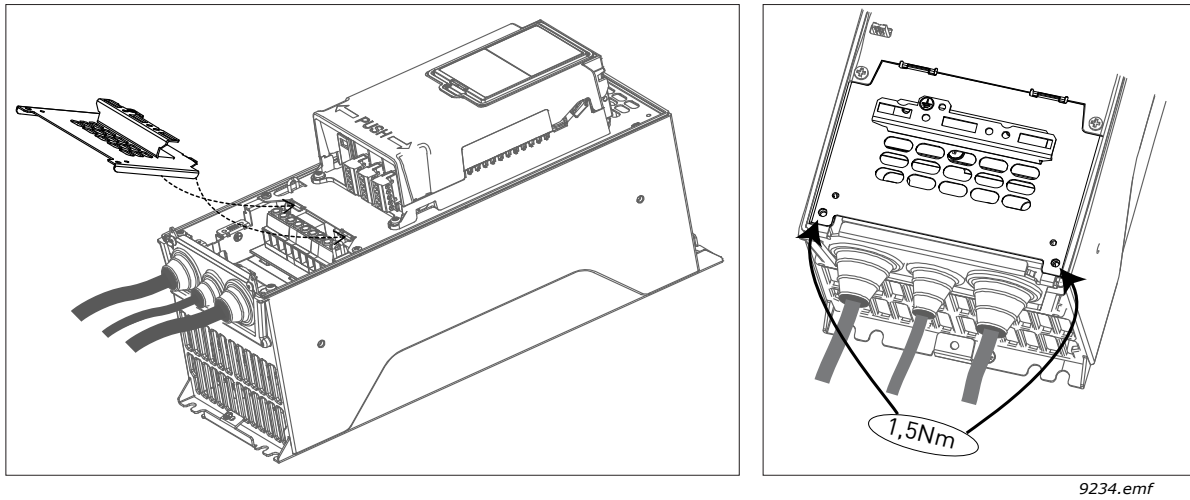

Figure 33. Additional protective earthing connector

9 Re-mount the cable protection plate (Figure 34) and the cover of the AC drive.



9234.emf

Figure 34. Re-mounting of cover components

5.3.2 FRAMES MR8 AND MR9

1 Strip the motor, mains and brake resistor cables as advised below.

NOTE! Dynamic braking and brake resistor is not supported in Vacon 100 FLOW.

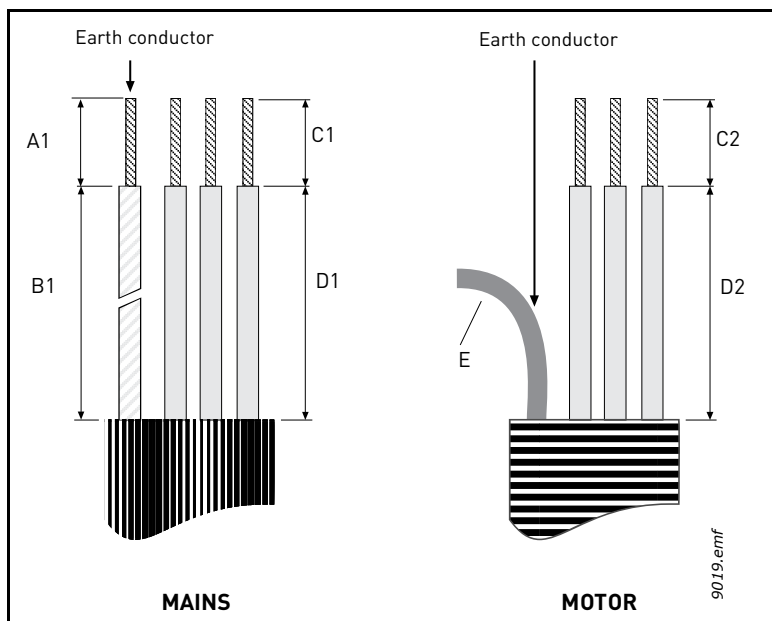

Figure 35. Stripping of cables

Table 18. Cables stripping lengths [mm]

Frame	A1	B1	C1	D1	C2	D2	E
MR8	40	180	25	300	25	300	Leave as short as possible
MR9	40	180	25	300	25	300	

2 MR9 only: Remove the main cover of the AC drive.

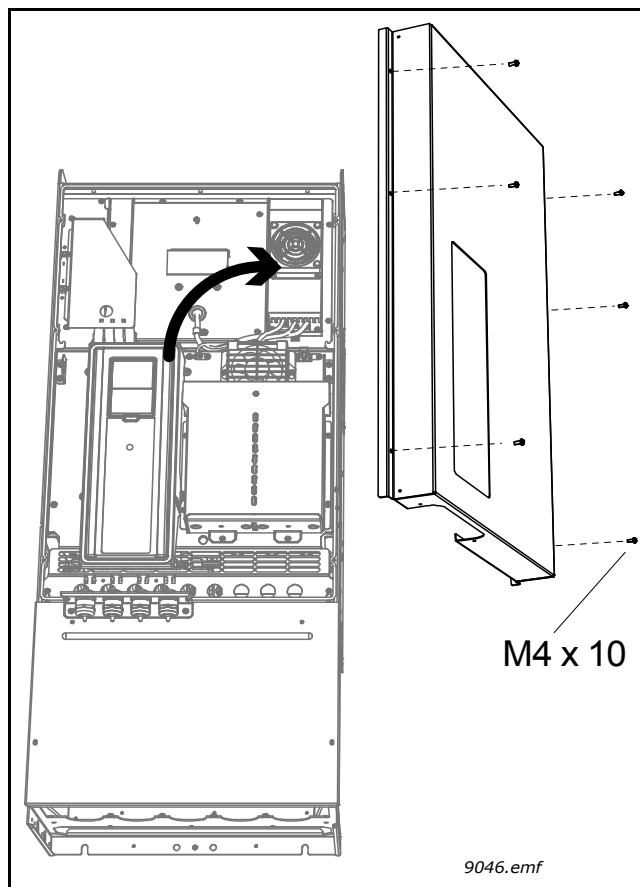

Figure 36. Removing main cover (MR9)

3 Remove the cable cover (1) and the cable fitting plate (2).

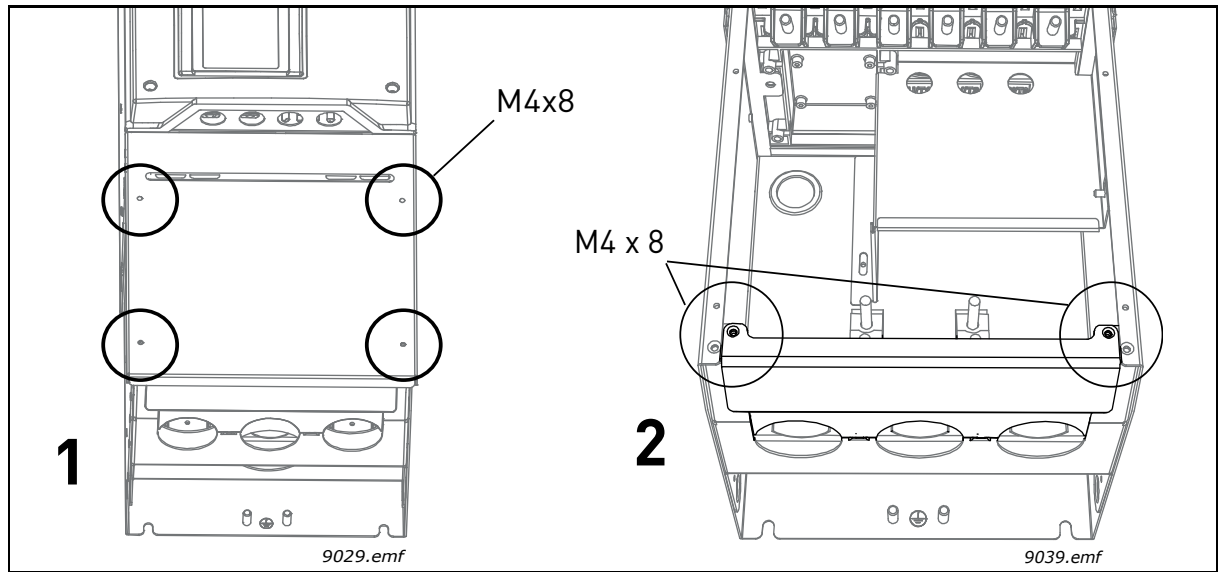

Figure 37. Removing cable cover and cable fitting plate (MR8).

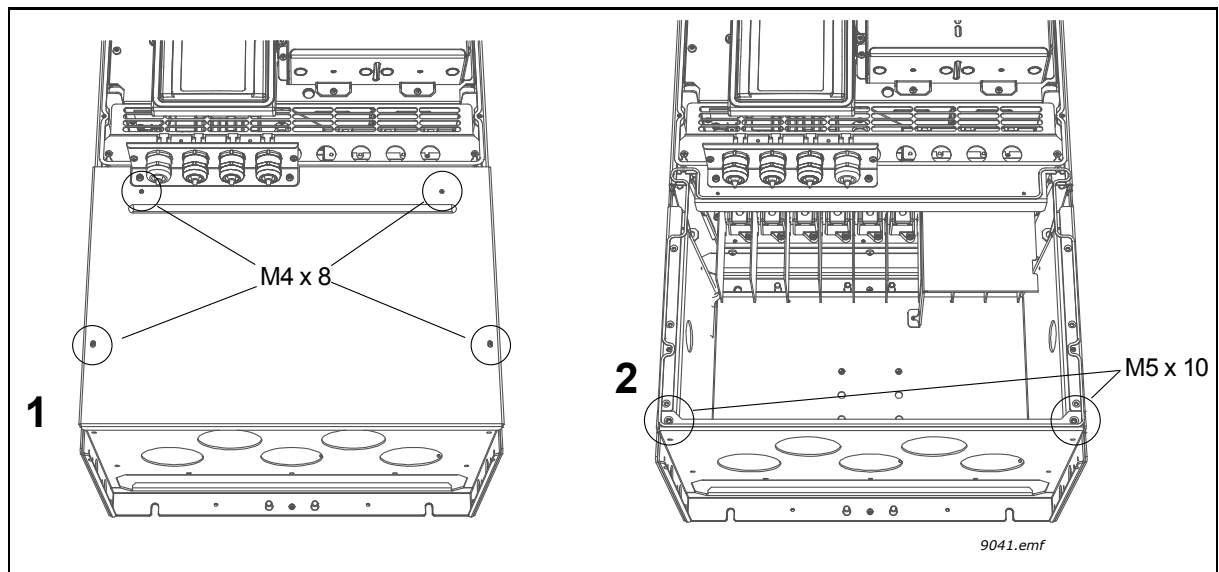

Figure 38. Removing cable cover and cable fitting plate (MR9).

4 MR9 only: Loosen the screws and remove the sealing plate.

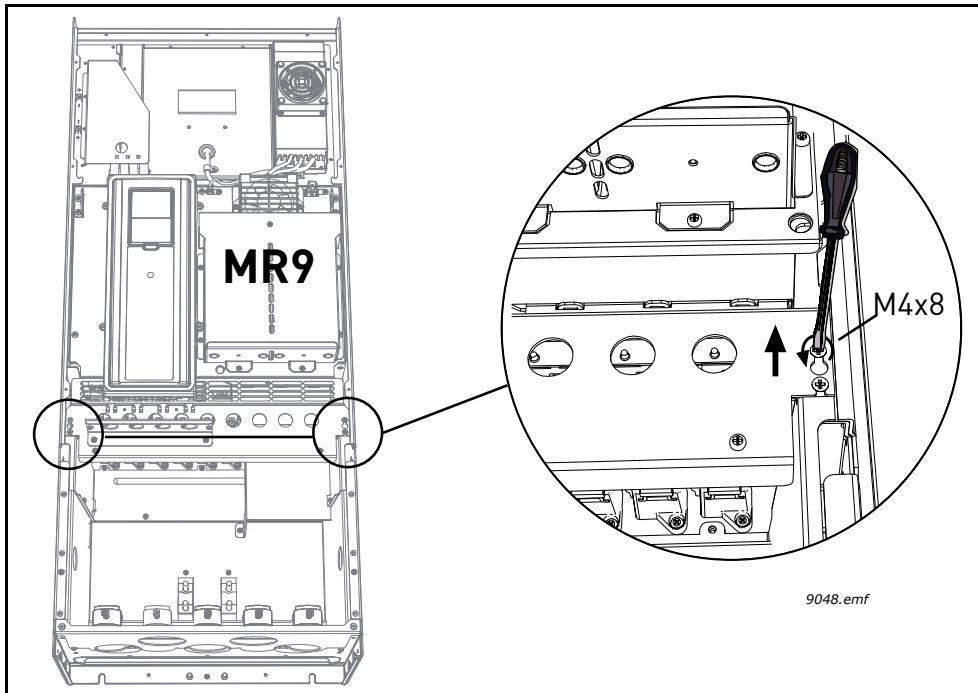

Figure 39. Removing sealing plate (MR9)

5 Remove the EMC shield plate.

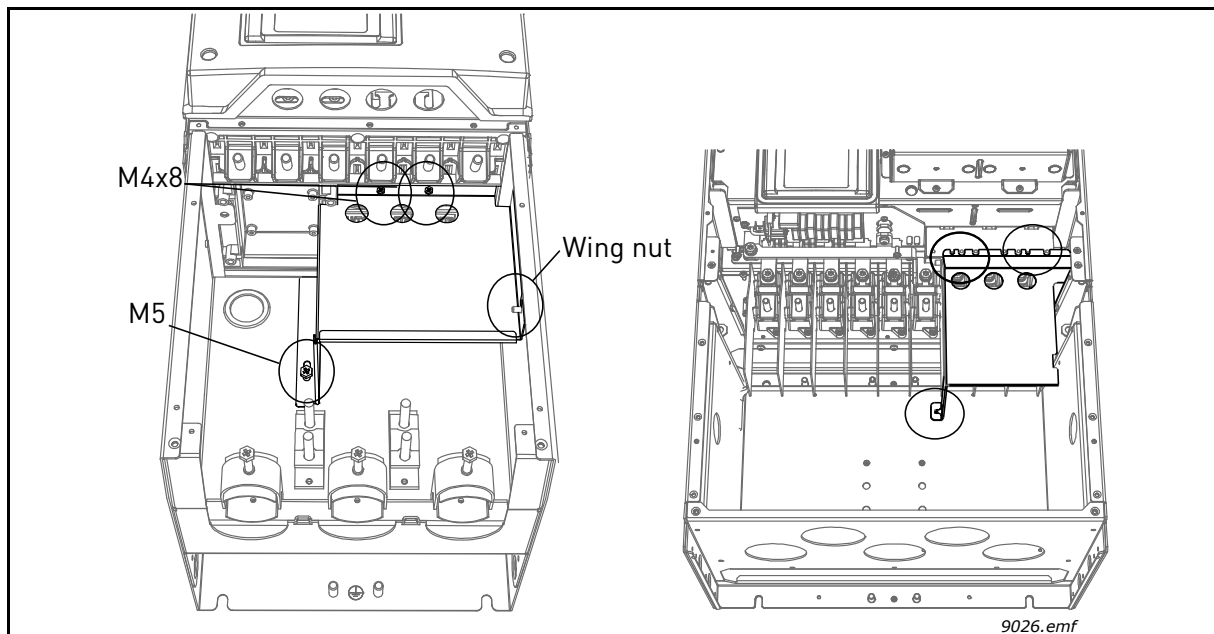

Figure 40. Removing EMC shield plate, left: MR8, right: MR9

6

Locate the terminals. **OBSERVE** the exceptional placement of motor cable terminals especially in frame MR8!

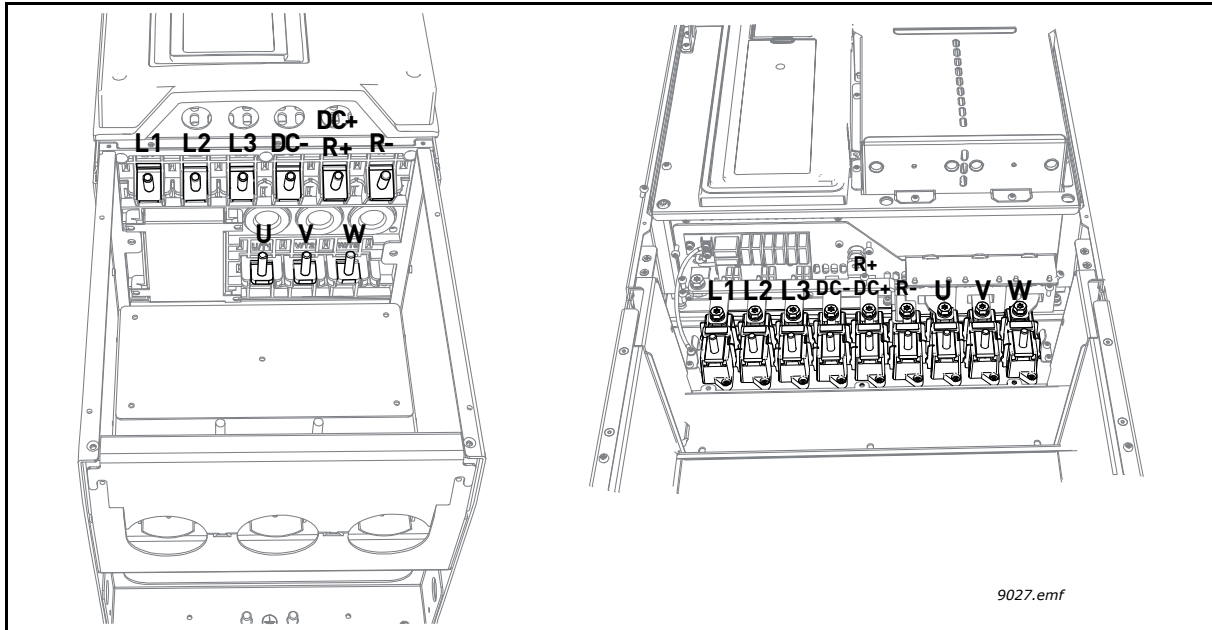

Figure 41. Power terminals, left: MR8, right: MR9

7

Cut the rubber grommets open to slide the cables through. Should the grommets fold in while inserting the cable, just draw the cable back a bit to straighten the grommets up. Do not cut the grommet openings wider than what is necessary for the cables you are using.

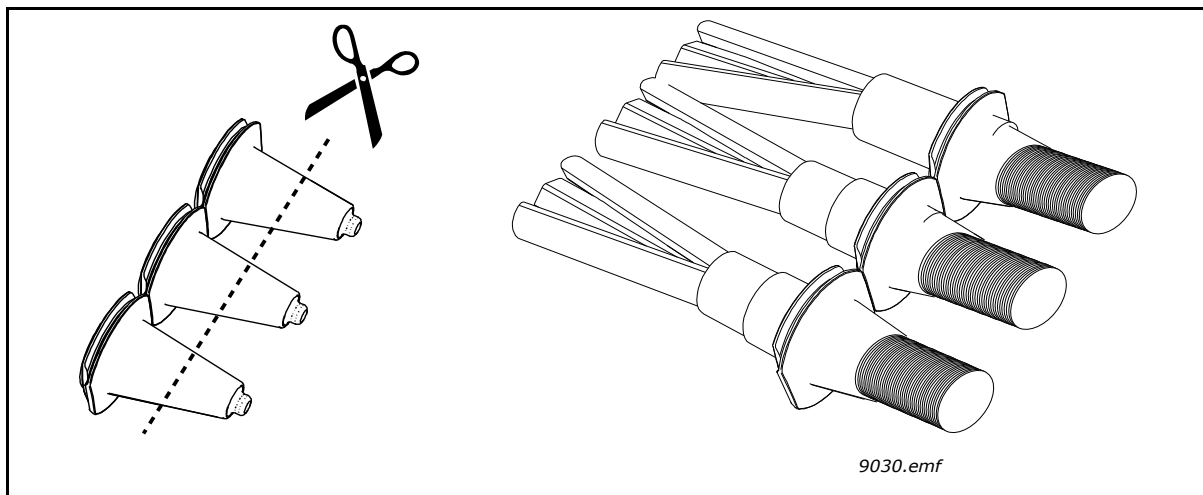

Figure 42. Cutting the cable grommets

8 Place the grommet with the cable so that the frame end plate fits in the groove on the grommet, see Figure 43.
 To meet the requirements of the enclosure class IP54, the connection between the grommet and the cable must be tight. Therefore, lead the first bit of the cable out of the grommet **straight** before letting it bend. If this is not possible, the tightness of the connection must be ensured with insulation tape or a cable tie. As an example, see Figure 29.

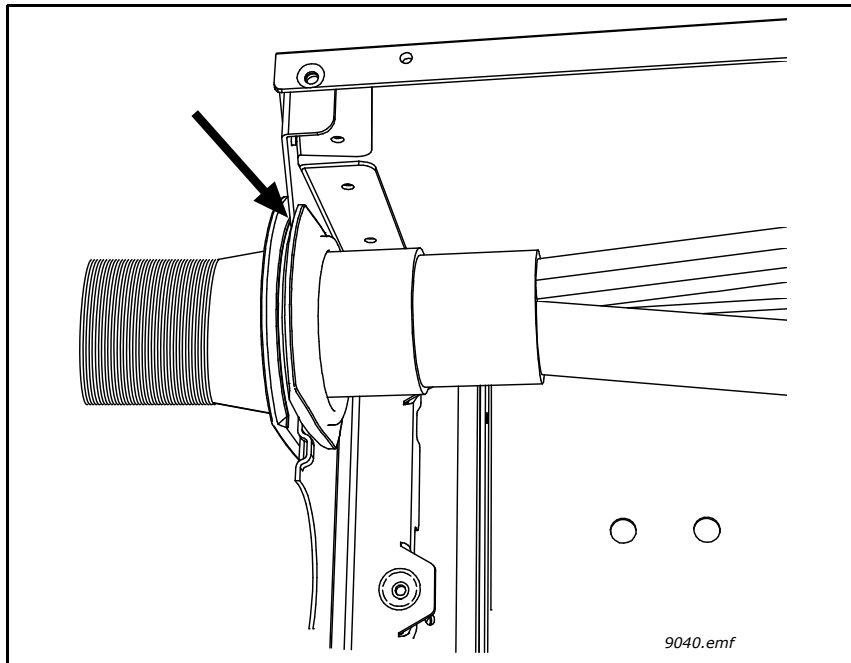

Figure 43. Placing the grommet

9 If you use thick cables insert the cable insulators in between the terminals in order to avoid contact between the cables.

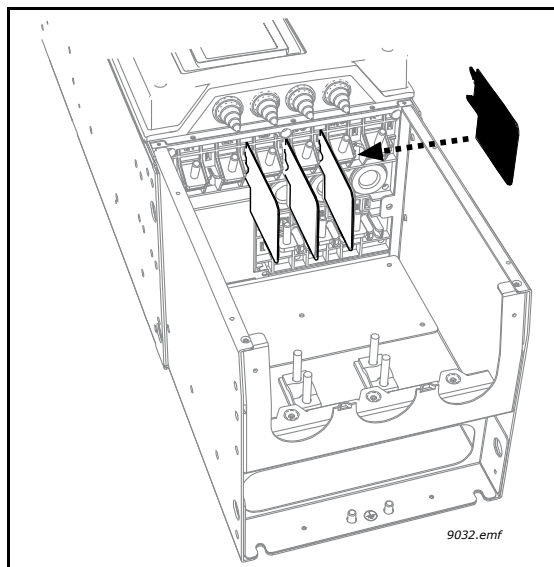

Figure 44. Inserting the cable insulators

10

Connect the cables stripped as shown in Figure 35.

- Connect the (phase) conductors of the supply, brake and motor cables into their respective terminals (a).
- Form the rest of the cable shield of all cables into "pigtails" and make a grounding connection as shown in Figure 45 (b) using the clamp from the *Accessories bag*.
- **NOTE:** If you use several cables on one connector observe the position of cable lugs on top of each other. See Figure 46 below.

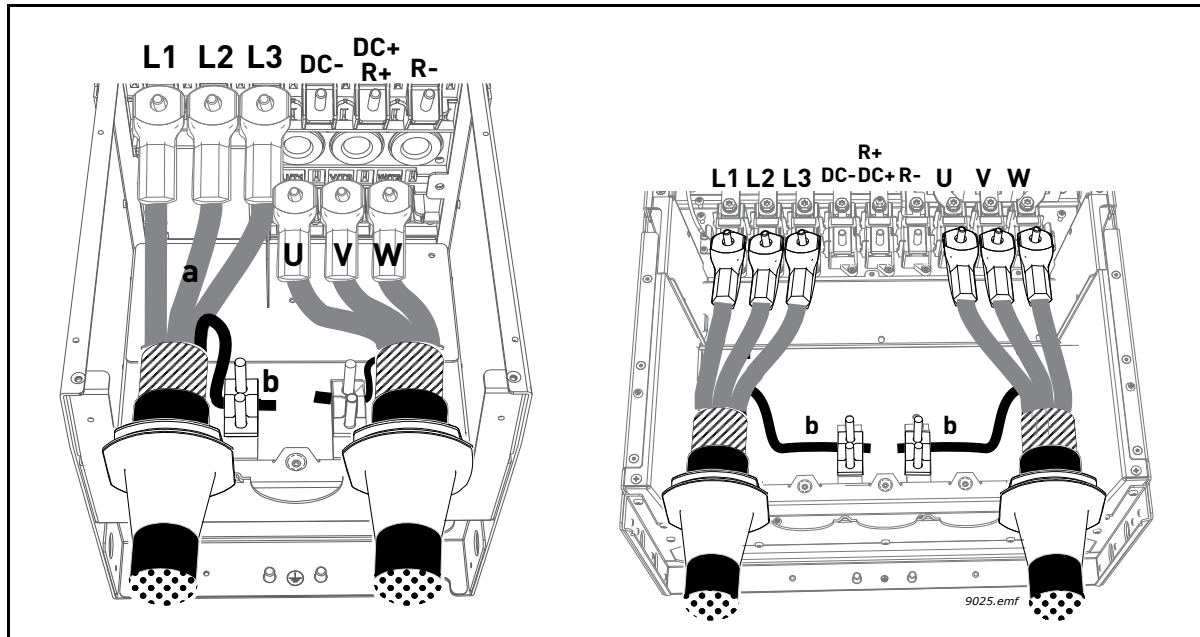

Figure 45. Connecting power cables, left: MR8, right: MR9

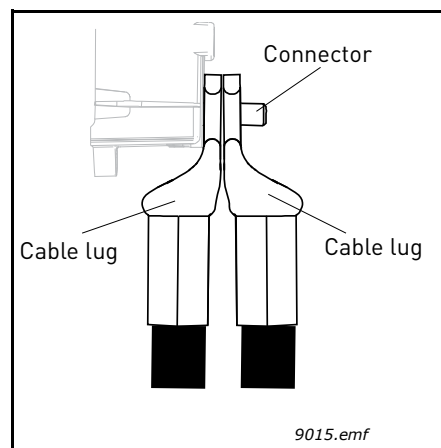

Figure 46. Placing two cable lugs on top of each other

Tightening torques of cable terminals:

Table 19. Tightening torques of terminals

Frame	Type	Tightening torque [Nm]/[lb-in.] Power and motor terminals		Tightening torque [Nm]/[lb-in.] EMC grounding clamps		Tightening torque, [Nm]/[lb-in.] Grounding terminals	
		[Nm]	lb-in.	[Nm]	lb-in.	[Nm]	lb-in.
MR8	0140 2—0205 2	20	177	1.5	13.3	20	177
	0140 5—0205 5						
MR9	0261 2—0310 2	20	177	1.5	13.3	20	177
	0261 5—0310 5						

11	Expose the shield of all three cables in order to make a 360-degree connection with the cable clamp.
-----------	--

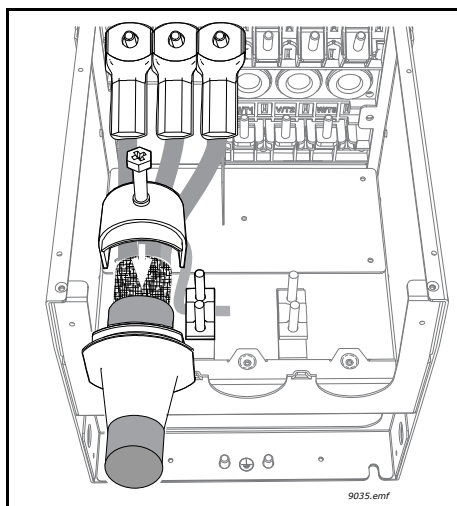

Figure 47. Exposing cable shields

12	Remount now first the EMC shield plate (see Figure 40) and then the sealing plate for MR9 (see Figure 39).
-----------	--

13 Re-attach then the cable fitting plate and then the cable cover.

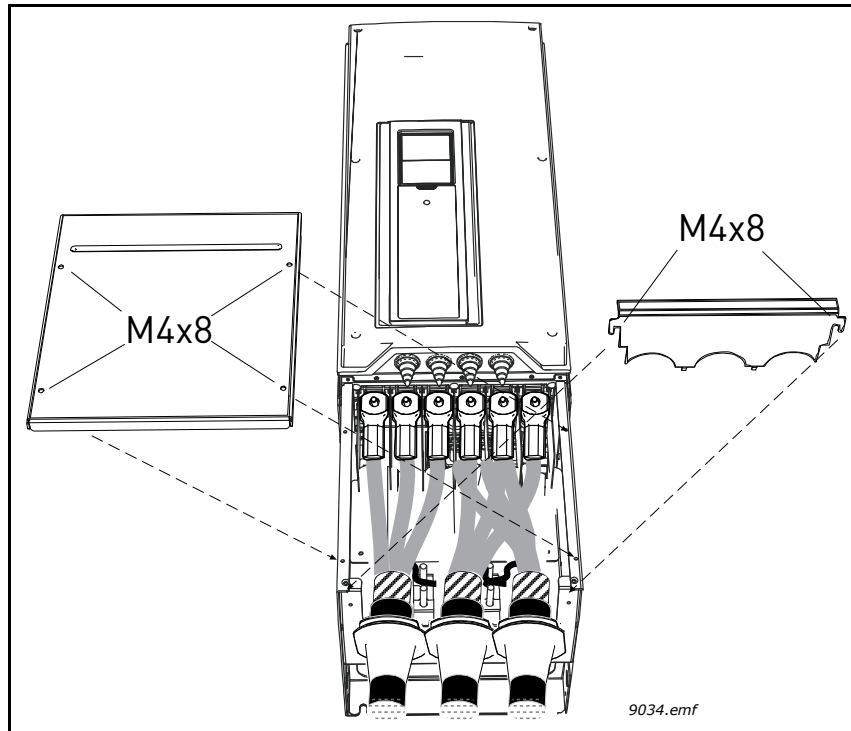

Figure 48. Reattaching cable fitting plate and cover

14 **MR9 only:** Now re-mount the main cover (unless you want to make the control connections first).

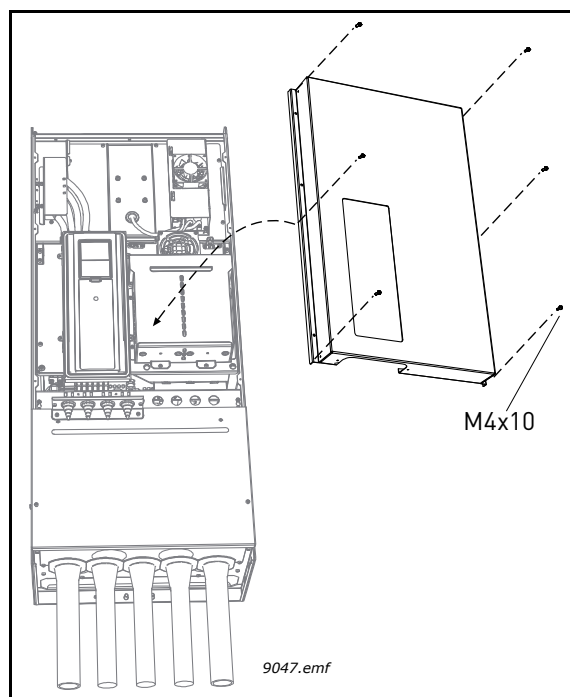



Figure 49. Re-mounting the main cover (MR9)

15

Check the connection of the earth cable to the motor and the AC drive terminals marked with .

NOTE: Two protective conductors are required according to standard EN61800-5-1. See chapter Earthing and earth fault protection.

Connect the protective conductor using a cable shoe and an M8 screw (included in the *Accessories bag*) on **either** of the screw connectors as advised in Figure 50.

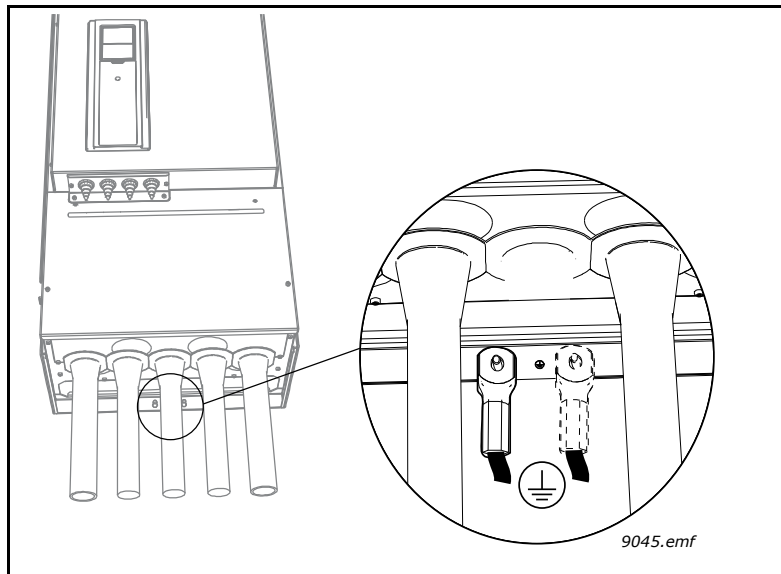

Figure 50. Connecting the protective conductor

5.4 INSTALLATION IN CORNER-GROUNDED NETWORK

Corner grounding is allowed for the drive types rating from 72 A to 310 A at 380...500 V supply and from 75 A to 310 A at 208...240 V supply.

In these circumstances the EMC protection class must be changed to level C4 following the instructions in Chapter 7.3 of this manual.

Corner grounding is not allowed for the drive types with rating from 3.4 A to 61 A at 380...500 V supply and 3.7 A to 62 A with 208...240 V supply.

6. CONTROL UNIT

The control unit of the AC drive consists of the standard boards and additional boards (option boards, see Chapter 6.3) connected to the slot connectors of the control board.

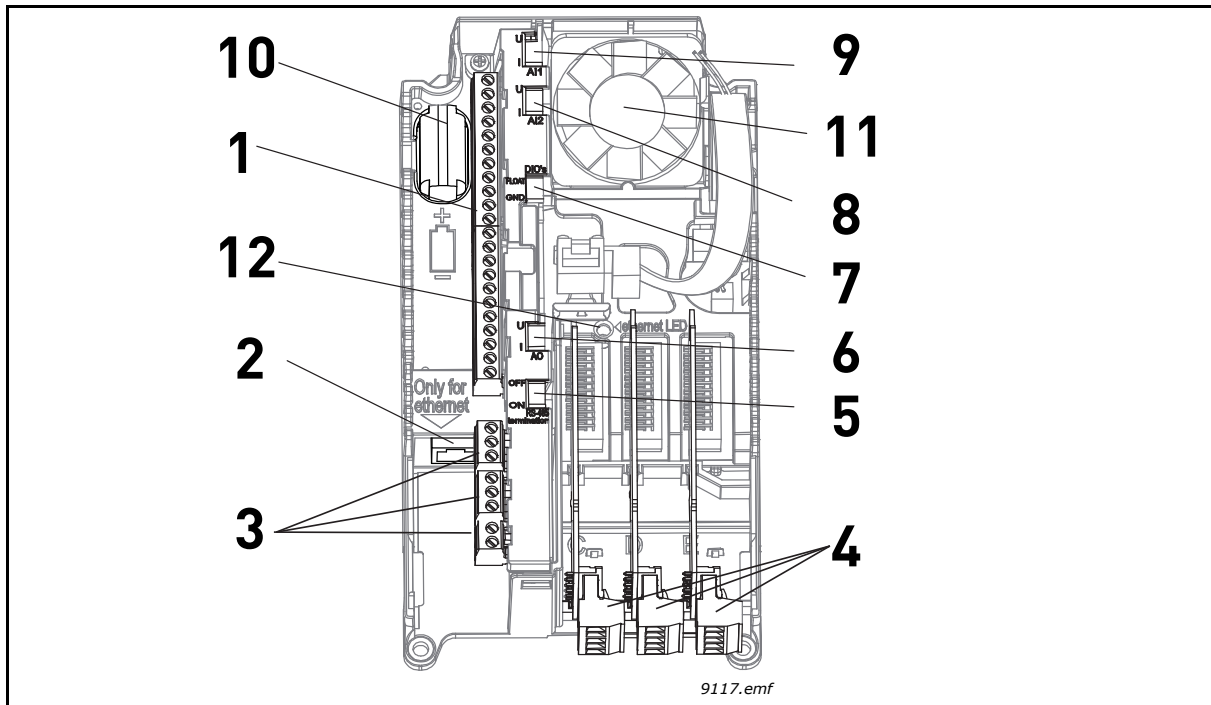

Figure 51. Location of control unit components

Locations of essential control unit components:

- 1 = Terminals for standard I/O connections; See Chapter 6.1.
- 2 = Ethernet connection
- 3 = Terminals for three relays connections (or optionally two relays and a termistor); See Chapter 6.1.
- 4 = Optional boards; See Chapter 6.3
- 5 = DIP switch for RS485 bus termination; See Chapter 6.2.2
- 6 = DIP switch for Analogue output signal selection; See Chapter 8.2.1
- 7 = DIP switch for isolating digital inputs from ground, see Chapter 6.1.2.2
- 8 = DIP switch for Analogue input 2 signal selection; See Chapter 8.2.1
- 9 = DIP switch for Analogue input 1 signal selection; See Chapter 8.2.1
- 10 = RTC Battery
- 11 = Fan (in frames MR4 and MR5 and protection class IP54 only)
- 12 = Ethernet led status

When delivered from the factory, the control unit of the AC drive contains the standard controlling interface - the control terminals of the control board and the relay board - unless otherwise specifically ordered. On the next pages you will find the arrangement of the control I/O and the relay terminals, the general wiring diagram and the control signal descriptions.

The control board can be powered externally (+24 VDC, 1000 mA, $\pm 10\%$) by connecting the external power source to terminal #30, see page 62. This voltage is sufficient for parameter setting and for keeping the control unit active. Note however that the measurements of the main circuit (e.g. DC-link voltage, unit temperature) are not available when the mains is not connected.

6.1 CONTROL UNIT CABLING

The standard control unit connections are presented in Figure 52 below. The control board is equipped with 22 fixed control I/O terminals and the relay board with 8. All signal descriptions are given in Figure 52.

6.1.1 CONTROL CABLE SIZING

The control cables shall be at least 0.5 mm² screened multicore cables, see Table . The maximum terminal wire size is 2.5 mm² for the relay and other terminals.

Find the tightening torques of the control and relay board terminals in Table below.

Table 20. Control cable tightening torques

Terminal screw	Tightening torque	
	Nm	lb-in.
All I/O and relay terminals (screw M3)	0.5	4.5

6.1.2 CONTROL TERMINALS AND DIP SWITCHES

The terminals of the *Basic I/O board* and the *Relay boards* are described below. For more information on the connections, see Chapter 8.2.1.

The terminals shown on shadowed background are assigned for signals with optional functions selectable with DIP switches. See more information in Chapter 6.1.2.1 on page 63.

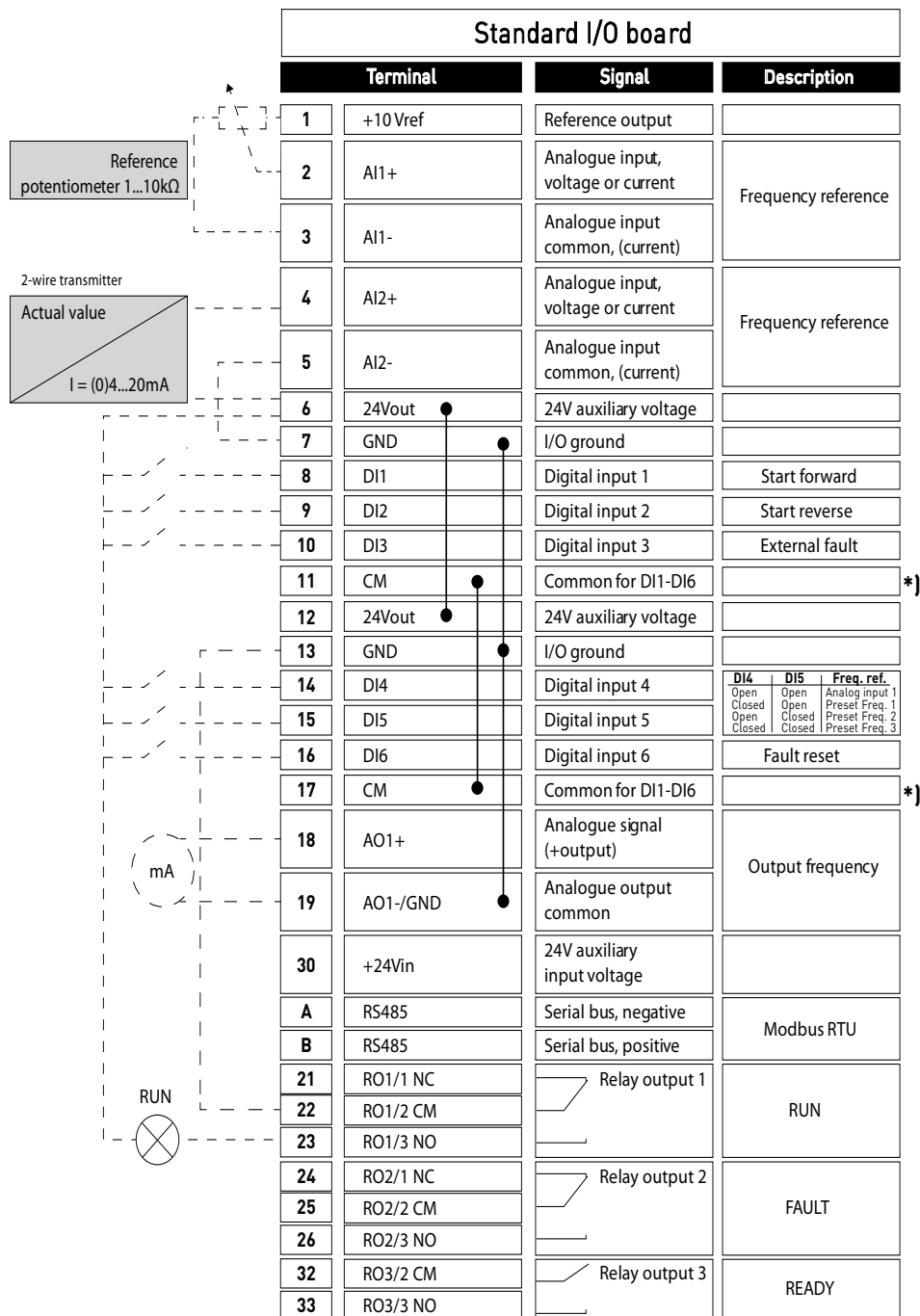

9111.emf

Figure 52. Control I/O terminal signals on basic I/O board and connection example

*Digital inputs can be isolated from ground with a DIP switch, see Chapter 6.1.2.2.

6.1.2.1 SELECTION OF TERMINAL FUNCTIONS WITH DIP SWITCHES

The shadowed terminals in Figure 52 allow for three functional selections each with the so-called *dip switches*. The switches have two positions, up and down. See figure to locate the switches and make appropriate selections for your requirements.

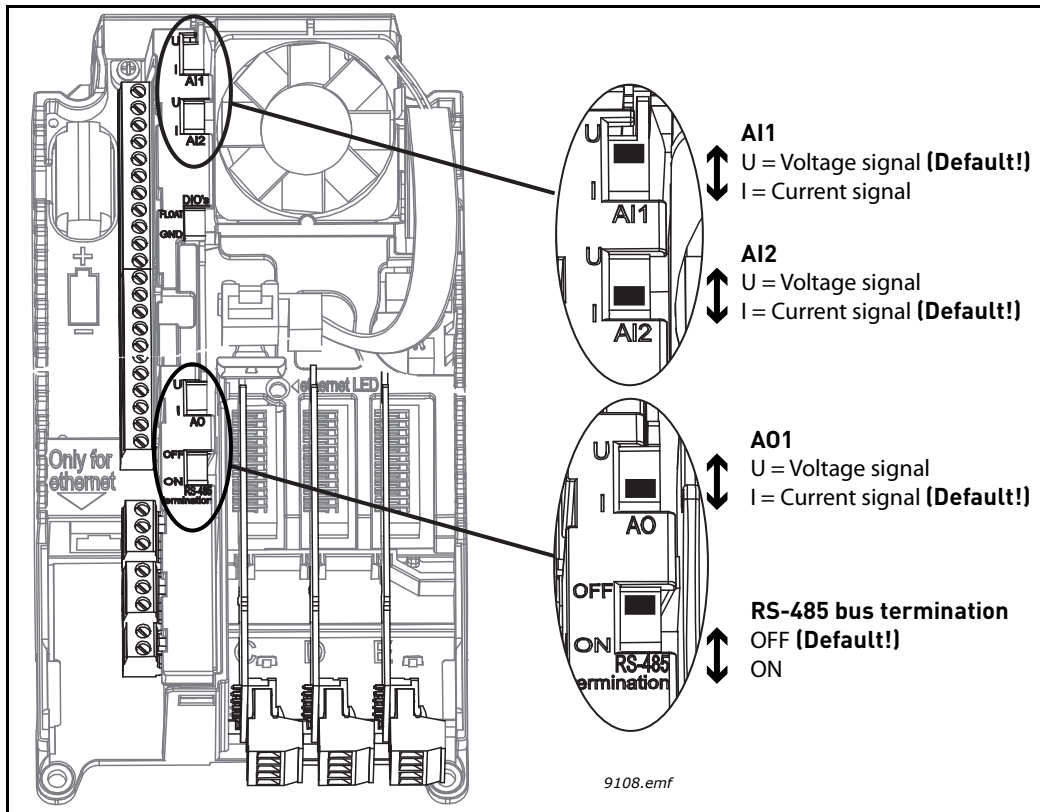

Figure 53. Dip switches

6.1.2.2 ISOLATING DIGITAL INPUTS FROM GROUND

The digital inputs (terminals 8-10 and 14-16) on the basic I/O board can be isolated from ground by changing the position of a dip switch on the control board. See Figure 54.

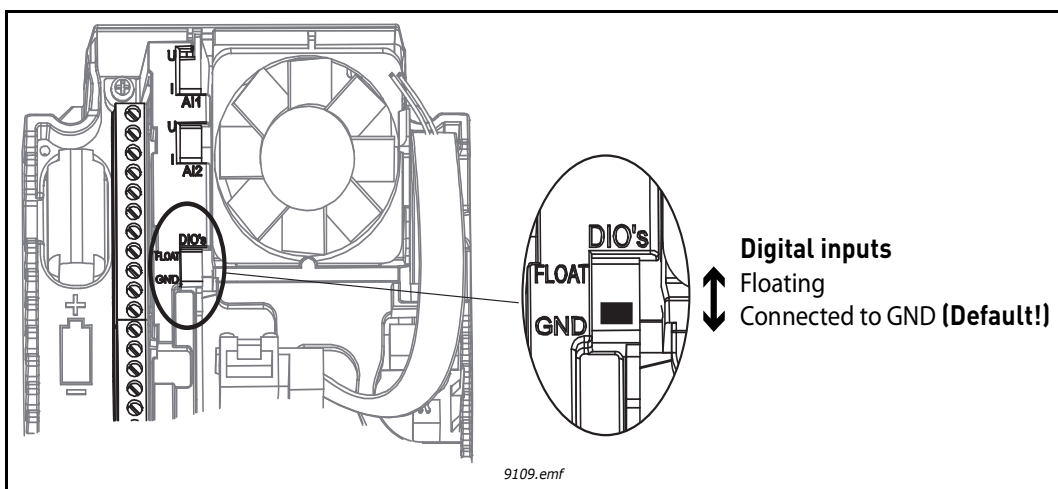

Figure 54. Change position of this jumper to isolate the digital inputs from ground.

6.2 FIELDBUS CONNECTION

The AC drive can be connected to fieldbus either through RS485 or Ethernet. The connection for RS485 is on the basic I/O board (terminals A and B) and the connection for Ethernet is under the drive cover, left to the control keypad. See Figure 55.

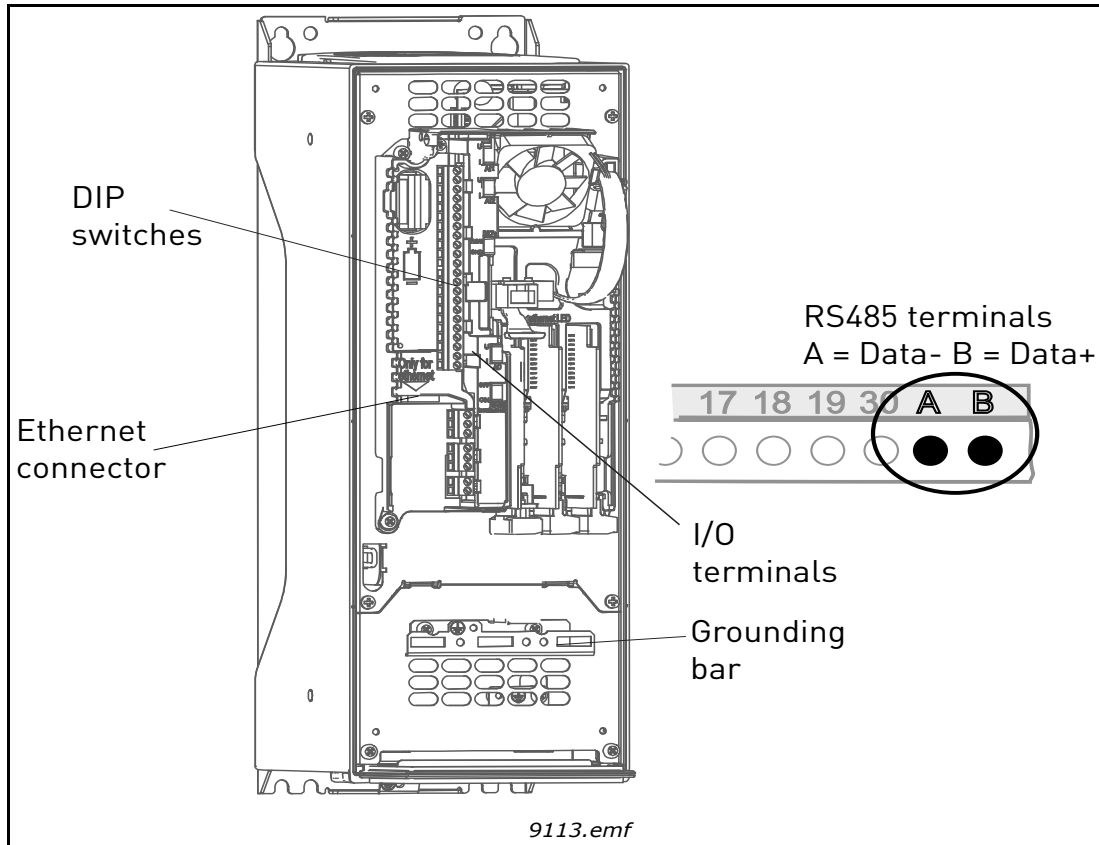

Figure 55. Ethernet and RS485 connections

6.2.1 PREPARE FOR USE THROUGH ETHERNET

6.2.1.1 ETHERNET CABLE DATA

Table 21. Ethernet cable data

Connector	Shielded RJ45 connector; NOTE: Max length of the connector 40mm.
Cable type	CAT5e STP
Cable length	Max .100m

1 Connect the Ethernet cable (see specification on page 65) to its terminal and run the cable through the rubber grommets as other I/O cables.

2

Protection class IP21: Cut free the opening on the AC drive cover for the Ethernet cable.

Protection class IP54: Cut the rubber grommets open to slide the cables through. Should the grommets fold in while inserting the cable, just draw the cable back a bit to straighten the grommets up. Do not cut the grommet openings wider than what is necessary for the cables you are using.

IMPORTANT: To meet the requirements of the enclosure class IP54, the connection between the grommet and the cable must be tight. Therefore, lead the first bit of the cable out of the grommet **straight** before letting it bend. If this is not possible, the tightness of the connection must be ensured with insulation tape or a cable tie.

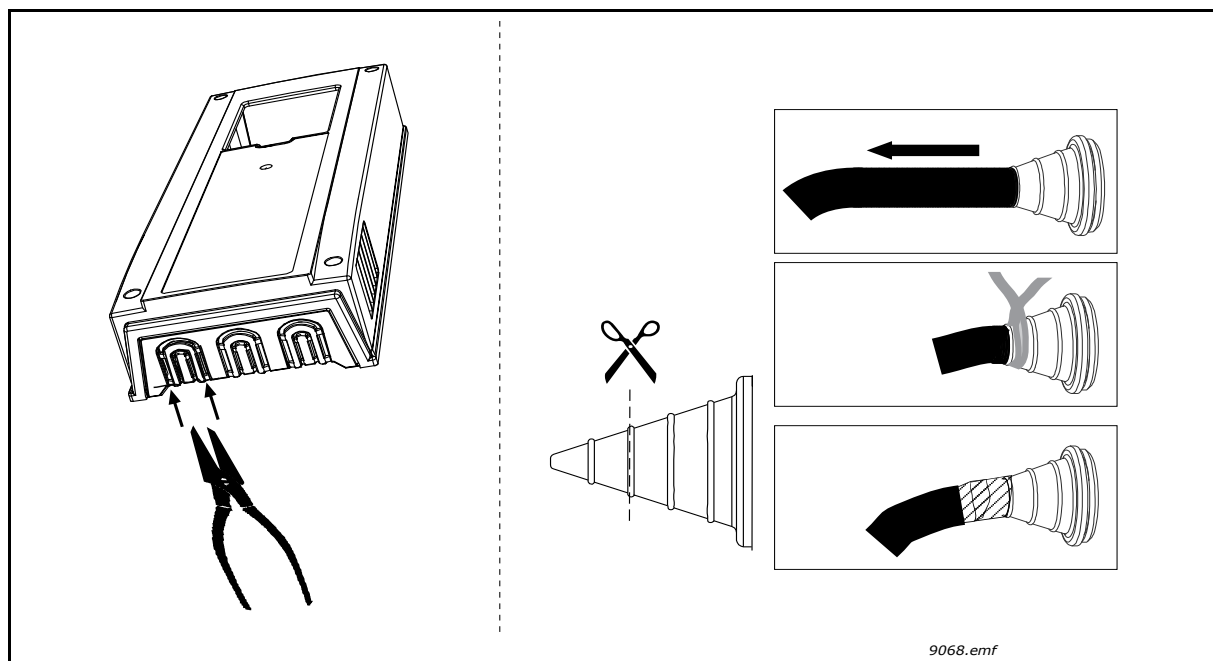

Figure 56. Leading the cables, left: IP21, right: IP54

3 Remount the AC drive cover. **NOTE:** When planning the cable runs, remember to keep the distance between the Ethernet cable and the motor cable at a **minimum of 30 cm.**

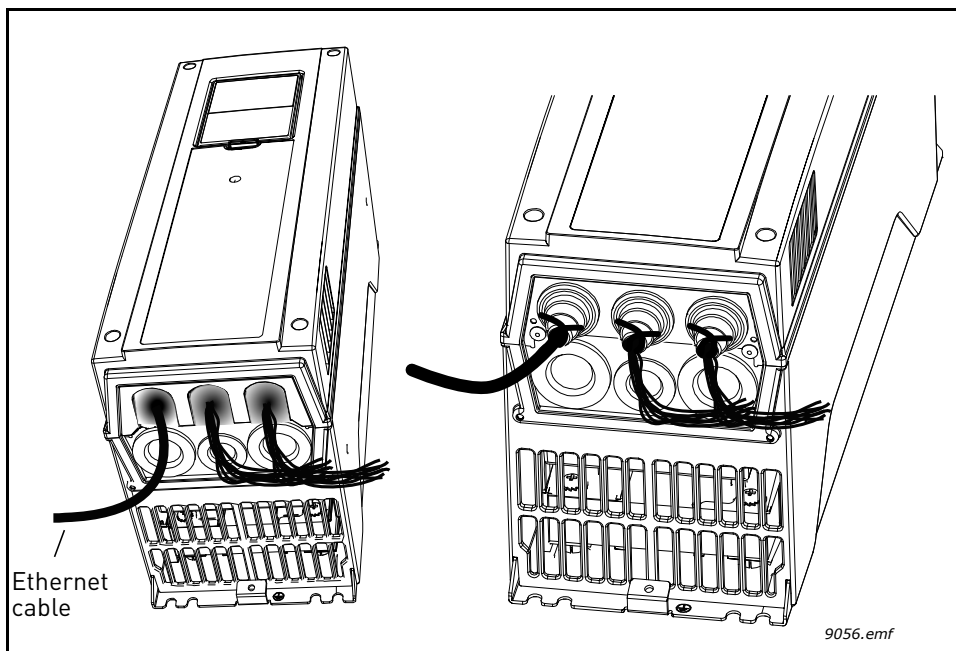

Figure 57. Distance between cables, left: IP21, right: IP54

For more detailed information, see the user’s manual of the fieldbus you are using.

6.2.2 PREPARE FOR USE THROUGH RS485

6.2.2.1 RS485 CABLE DATA

Table 22. RS485 cable data

Connector	2.5 mm ²
Cable type	STP (Shielded Twisted Pair), type Belden 9841 or similar
Cable length	Depends on the used fieldbus. See respective bus manual.

Strip about 15 mm of the RS485 cable (see specification on page 66) and cut off the grey cable shield. Remember to do this for both bus cables. Leave no more than 10 mm of the cable outside the terminal block and strip the cables at about 5 mm to fit in the terminals. See picture below.

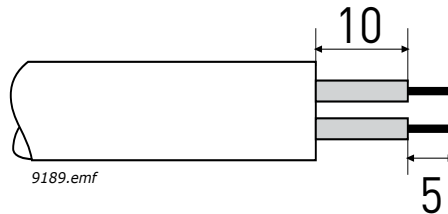

1

Also strip the cable now at such a distance from the terminal that you can fix it to the frame with the grounding clamp. Strip the cable at a maximum length of 15 mm. **Do not strip the aluminum cable shield!**

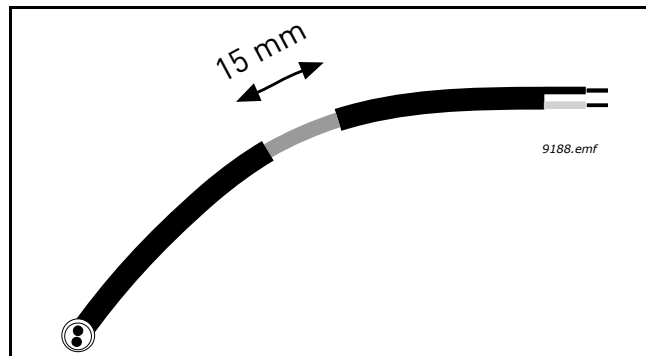

2

Then connect the cable to its appropriate terminals on Vacon 100 AC drive standard terminal block, terminals **A and B** (A = negative, B = positive). See Figure 58.

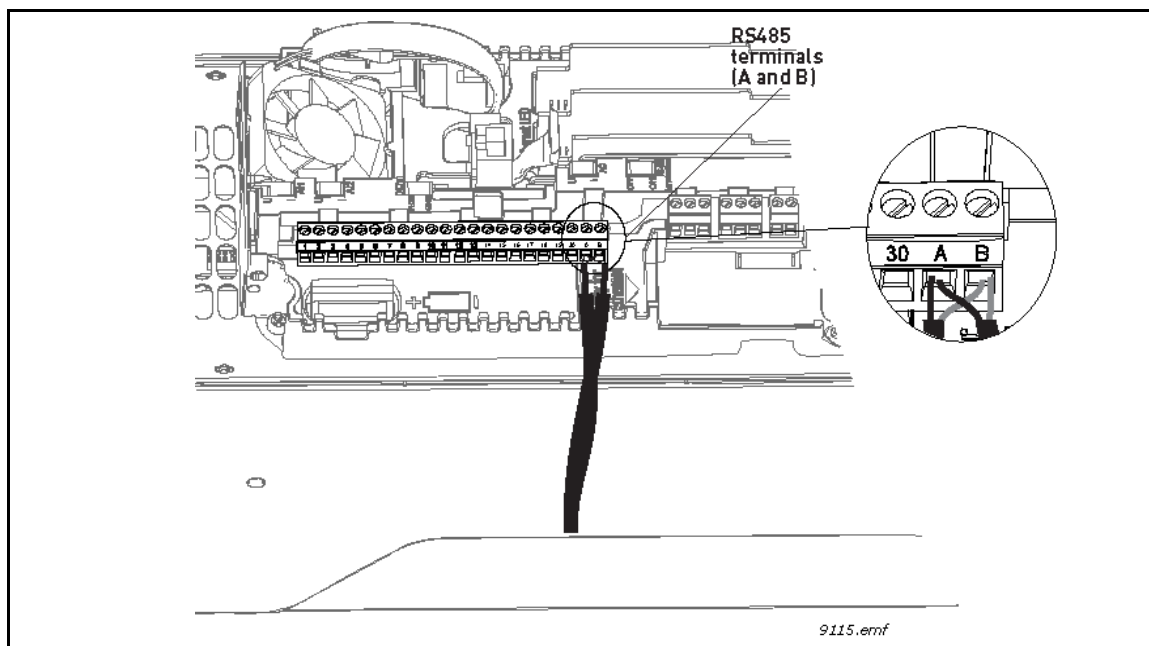
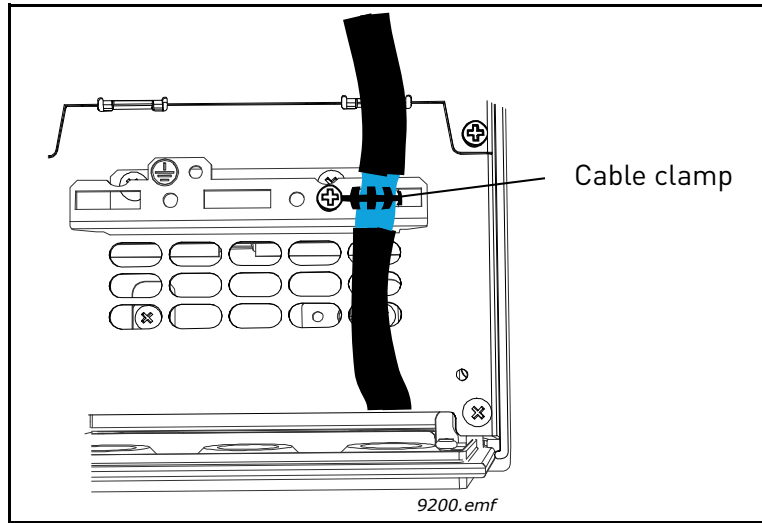

Figure 58. Connecting the RS485 cable

3

Using the cable clamp included in the delivery of the drive, ground the shield of the RS485 cable to the frame of the AC drive.



4

If the AC drive is the last device on the bus, the bus termination must be set. Locate the DIP switches to the right of the control keypad of the drive and turn the switch for the RS485 bus termination resistor to position ON. Biasing is built in the termination resistor (resistance = 120 ohm). See also step 7 on page 69.

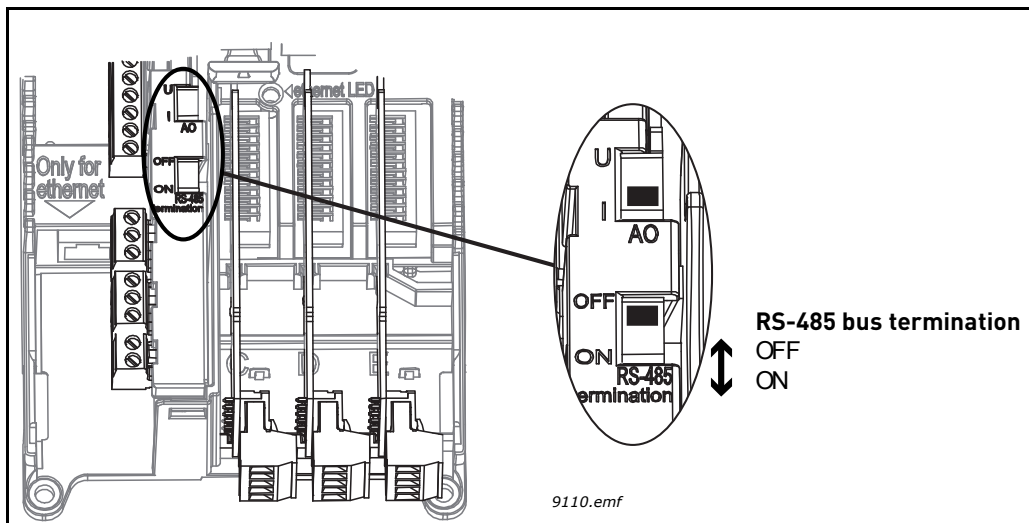

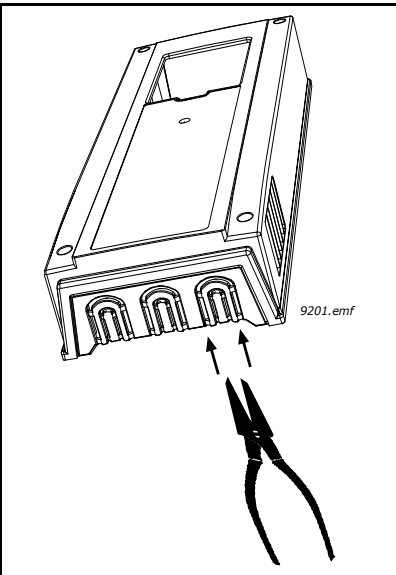
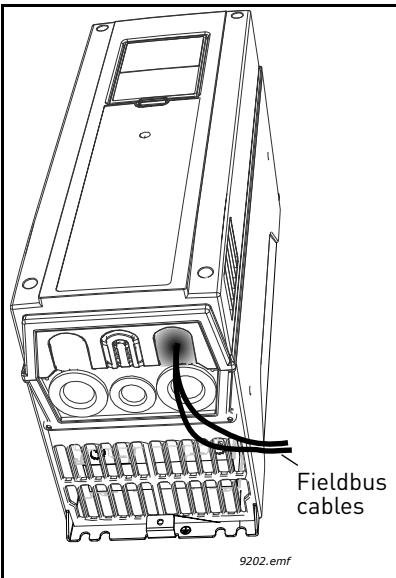
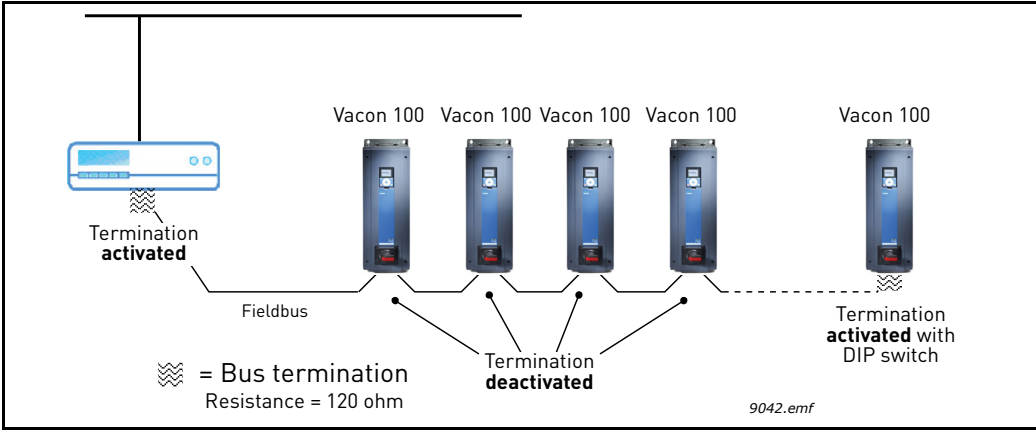
<p style="text-align: center; font-size: 2em; font-weight: bold;">5</p>	<p>Unless already done for the other control cables, cut free the opening on the AC drive cover for the RS485 cable (protection class IP21).</p>	
<p style="text-align: center; font-size: 2em; font-weight: bold;">6</p>	<p>Remount the AC drive cover and run the RS485 cables as shown in picture. NOTE: When planning the cable runs, remember to keep the distance between the Ethernet, I/O and Fieldbus cables and the motor cable at a minimum of 30 cm. It is recommended to route the fieldbus cables away from the power cables as shown in the picture.</p>	
<p style="text-align: center; font-size: 2em; font-weight: bold;">7</p>	<p>The bus termination must be set for the first and the last device of the fieldbus line. See picture below. See also step 4 on page 68. We recommend that the first device on the bus and, thus, terminated was the Master device.</p> 	

6.3 OPTION BOARD INSTALLATION



NOTE! It is not allowed to add or replace option boards or fieldbus boards on an AC drive with the power switched on. This may damage the boards.

The option boards are placed in the board slots on the drive.

The table below gives information about which option board can be placed in which board slot on the drive.

Table 23. Option board compatibilities for board slots

Option board type	Board description	Insertable in slots
OPTB1	I/O expander board	C, D, E
OPTB2	Thermistor relay board	C, D, E
OPTB4	I/O expander board	C, D, E
OPTB5	Relay board	C, D, E
OPTB9	I/O expander board	C, D, E
OPTBF	I/O expander board	C, D, E
OPTBH	Temperature measurement board	C, D, E
OPTBJ	Safe Torque-Off board	E
OPTC4	LonWorks fieldbus board	D, E
OPTE3	Profibus DPV1 fieldbus board	D, E
OPTE5	Profibus DPV1 fieldbus board (D type connector)	E
OPTE6	CanOpen fieldbus board	D, E
OPTE7	DeviceNet fieldbus board	D, E

1

Open the cover of the AC drive.



The relay outputs and other I/O-terminals may have a dangerous control voltage present even when the drive is disconnected from mains.

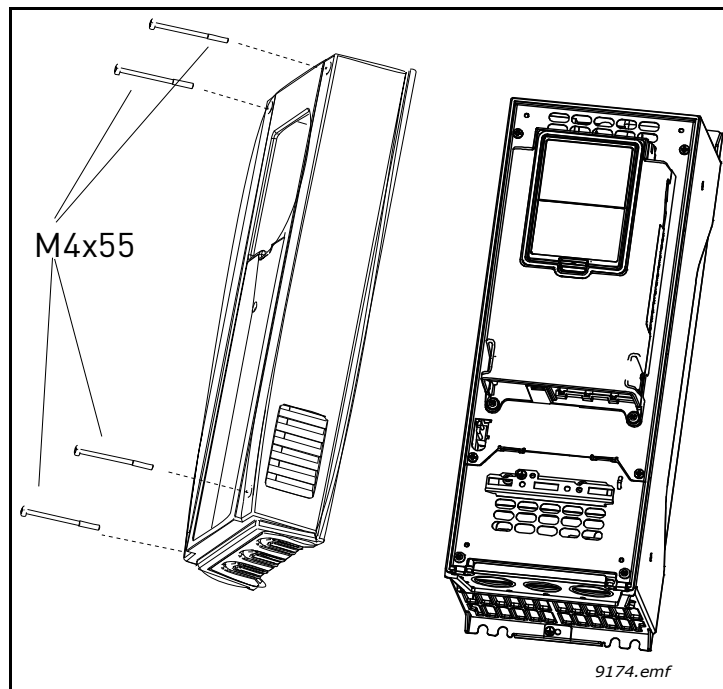
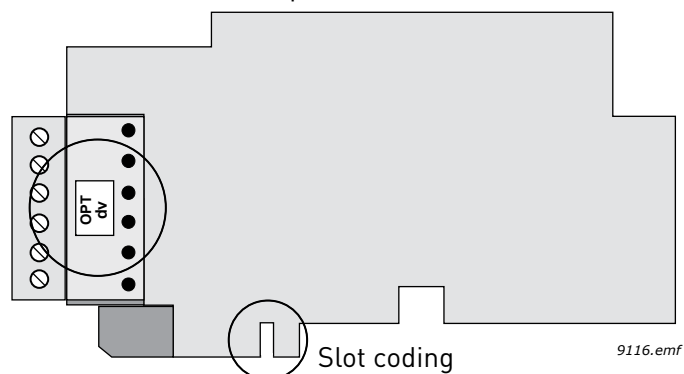

Figure 59. Opening the main cover

2

Make sure that the sticker on the connector of the board says "dv" (dual voltage). This indicates that the board is compatible with Vacon 100. See below:



NOTE: Incompatible boards cannot be installed on Vacon 100. Compatible boards have a slot coding that enable the placing of the board (see above)

3

To reveal the option board slots, open the control unit cover as shown in picture below.

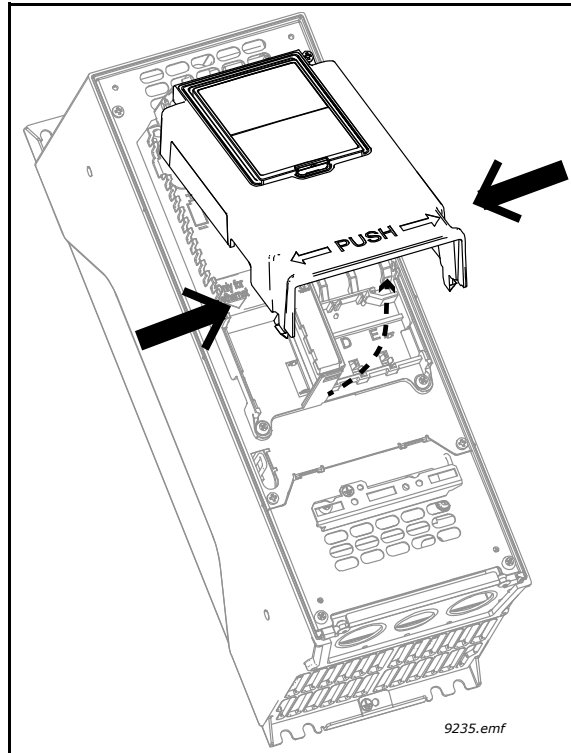

4

Install the option board into the appropriate slot **C**, **D** or **E** (see Table 23 on page 70 and Figure below). Close the cover of the control unit and remount the keypad.

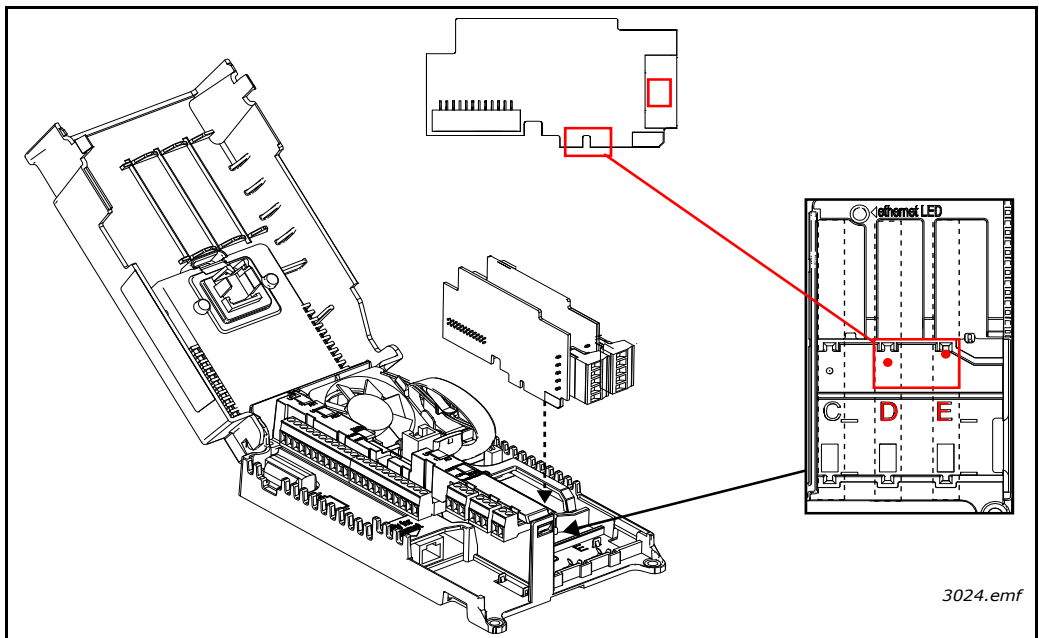

6.4 BATTERY INSTALLATION FOR REAL TIME CLOCK (RTC)

Enabling the functions of the *Real Time Clock (RTC)* requires that an optional battery is installed in the drive.

Use ½ AA battery with voltage of 3.6 V and capacity of 1000...1200 mAh (e.g. Panasonic BR-1/2 AA or Vitzrocell SB-AA02). The battery will last approximately ten years.

The place for the battery can be found in all frames left to the control keypad (see Figure 51).

Detailed information on the functions of the *Real Time Clock (RTC)* can be found in the Vacon 100 Application Manual.

6.5 GALVANIC ISOLATION BARRIERS

The control connections are isolated from the mains potential and the GND terminals are permanently connected to ground. See Figure 60.

The digital inputs are galvanically isolated from the I/O ground. The relay outputs are additionally double-isolated from each other at 300VAC (EN-50178).

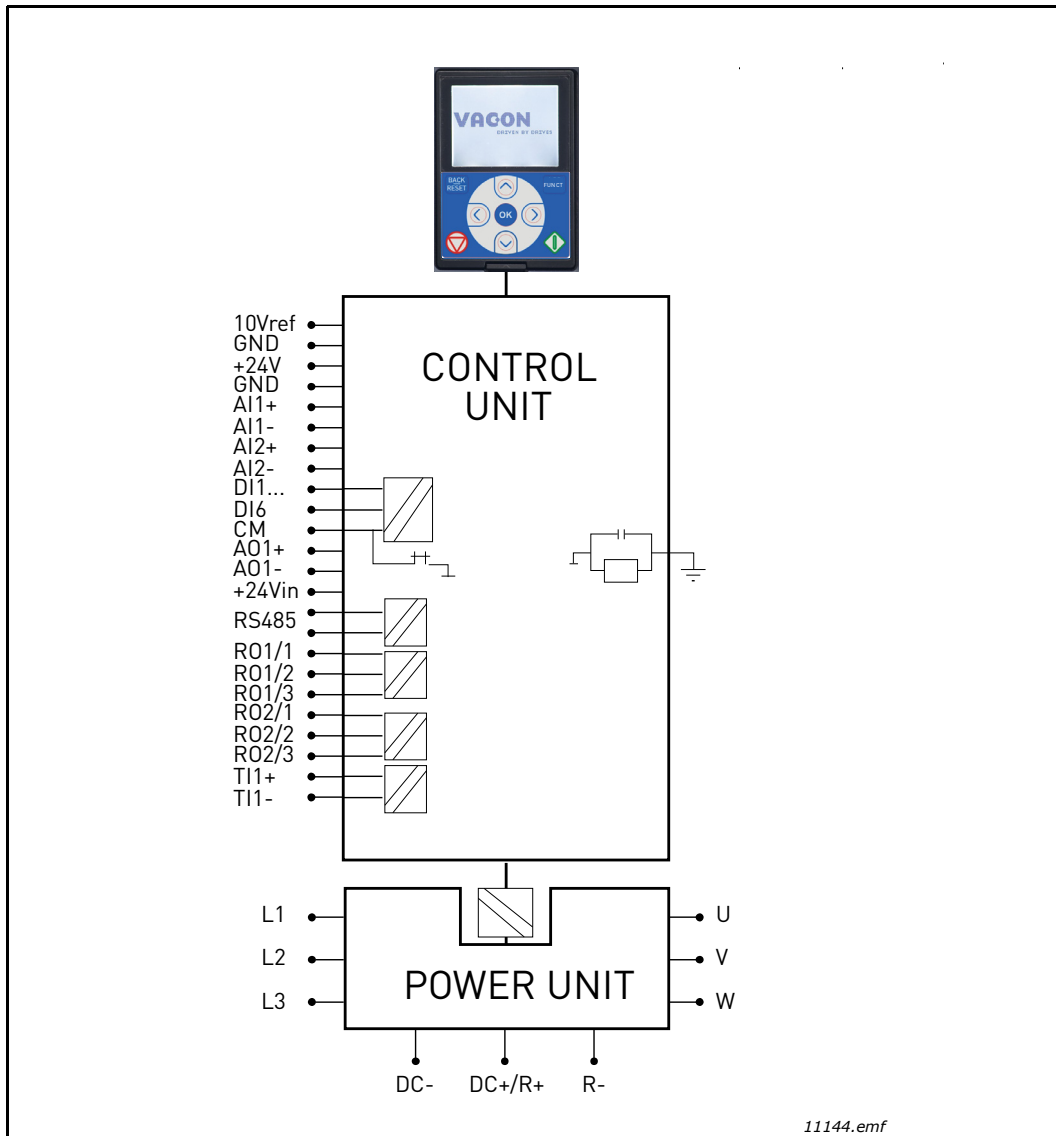

Figure 60. Galvanic isolation barriers

7. COMMISSIONING

Before commissioning, note the following directions and warnings:



Internal components and circuit boards of Vacon 100 (except for the galvanically isolated I/O terminals) are live when it is connected to mains potential. **Coming into contact with this voltage is extremely dangerous and may cause death or severe injury.**



The motor terminals **U, V, W** and the brake resistor terminals (**R+/R-** (MR4-MR6) or **DC+/R+** and **R-** (MR7 and bigger)) **are live** when Vacon 100 is connected to mains, **even if the motor is not running.**



The control I/O-terminals are isolated from the mains potential. However, the **relay outputs and other I/O-terminals may have a dangerous control voltage** present even when Vacon 100 is disconnected from mains.



Do not make any connections to or from the AC drive when it is connected to the mains.



After disconnecting the AC drive from the mains, **wait** 5 minutes before doing any work on the connections of Vacon100. Do not open the cover before this time has expired. After expiration of this time, use a measuring equipment to absolutely ensure that no voltage is present. **Always ensure absence of voltage before electrical work!**



Before connecting the AC drive to mains make sure that the front and cable covers of Vacon 100 are closed.

NOTE! Dynamic braking and brake resistor is not supported in Vacon 100 FLOW, but brake resistor terminals might still be live and carry a hazardous voltage.

7.1 COMMISSIONING OF THE DRIVE

Read carefully the safety instructions in Chapter 2 and above and follow them.

After the installation:

- Check that both the AC drive and the motor are **grounded**.
- Check that the mains, brake and motor cables **comply with the requirements** given in Chapter 5.1.1.
- Check that the control cables are **located as far as possible** from the power cables, see Chapter 5.3.
- Check that the **shields** of the shielded cables are **connected to protective earth** marked with .
- Check the **tightening torques** of all terminals
- Check that the **wires do not touch** the electrical components of the drive.
- Check that the common inputs of digital input groups are connected to +24 V or ground of the I/O terminal or the external supply.
- Check the **quality and quantity** of cooling air (Chapter 4.2 and Table 12).
- Check the inside of the AC drive for **condensation**.
- Check the installation space for **foreign objects**.
- Check that all Start/Stop switches connected to the I/O terminals are in Stop-position.**
- Before connecting the AC drive to mains: Check **mounting and condition** of all fuses and other protective devices.
- Run the Startup Wizard (see the Application Manual).

7.2 RUNNING THE MOTOR

MOTOR RUN CHECK LIST



Before starting the motor, check that the motor is **mounted properly** and ensure that the machine connected to the motor allows the motor to be started.



Set the maximum motor speed (frequency) according to the motor and the machine connected to it.



Before reversing the motor make sure that this can be done safely.



Make sure that no power correction capacitors are connected to the motor cable.



Make sure that the motor terminals are not connected to mains potential.

7.2.1 CABLE AND MOTOR INSULATION CHECKS

1. Motor cable insulation checks
Disconnect the motor cable from terminals U, V and W of the AC drive and from the motor. Measure the insulation resistance of the motor cable between each phase conductor as well as between each phase conductor and the protective ground conductor. The insulation resistance must be $>1\text{ M}\Omega$ at ambient temperature of $20\text{ }^{\circ}\text{C}$.
2. Mains cable insulation checks
Disconnect the mains cable from terminals L1, L2 and L3 of the AC drive and from the mains. Measure the insulation resistance of the mains cable between each phase conductor as well as between each phase conductor and the protective ground conductor. The insulation resistance must be $>1\text{ M}\Omega$ at ambient temperature of $20\text{ }^{\circ}\text{C}$.
3. Motor insulation checks
Disconnect the motor cable from the motor and open the bridging connections in the motor connection box. Measure the insulation resistance of each motor winding. The measurement voltage must equal at least the motor nominal voltage but not exceed 1000 V . The insulation resistance must be $>1\text{ M}\Omega$ at ambient temperature of $20\text{ }^{\circ}\text{C}$. Always follow the instructions of the motor manufacturer.

7.3 INSTALLATION IN IT SYSTEM

If your supply network is an IT (impedance-grounded) system but your AC drive is EMC-protected according to class C2 you need to modify the EMC protection of the AC drive to EMC-level C4. This is done by removing the built-in EMC jumpers with a simple procedure described below:

	<p>Warning! Do not perform any modifications on the AC drive when it is connected to mains.</p>
---	---

7.3.1 FRAMES MR4 TO MR6

1	<p>Remove the main cover of the AC drive (see page 44) and locate the jumpers connecting the built-in RFI-filters to ground. See Figure 61.</p>
---	---

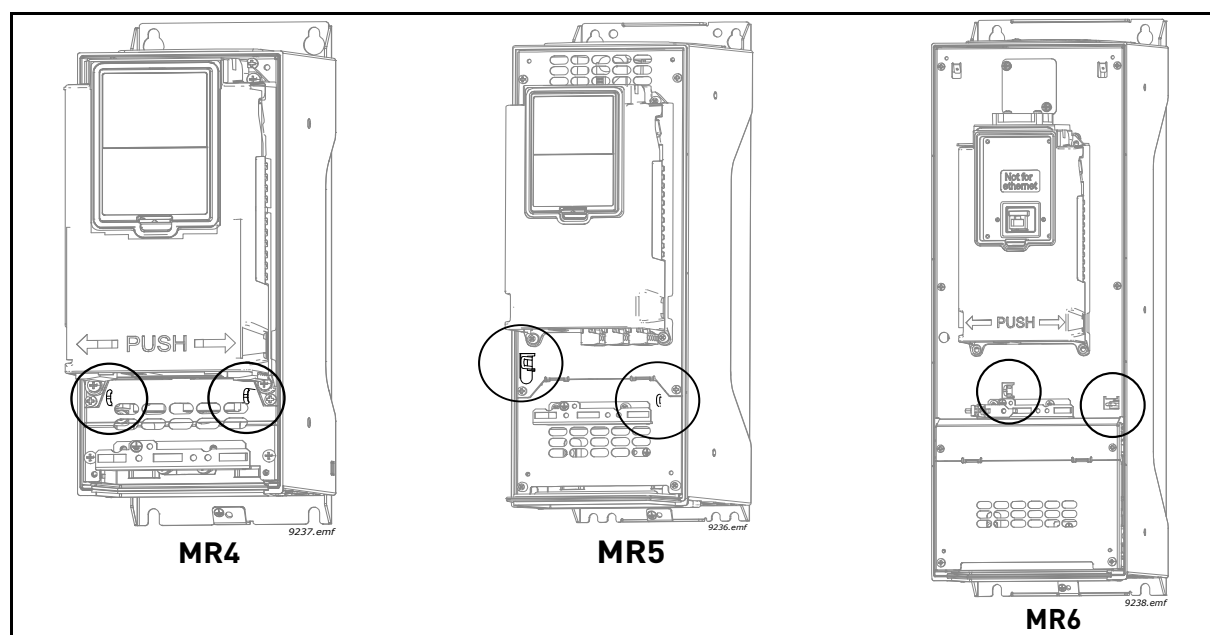

Figure 61. Locations of the EMC-jumpers in frames MR4 to MR6

2	<p>Disconnect the RFI-filters from ground by removing the EMC-jumpers. NOTE! The cable cover must be removed in MR4 and MR5 before the jumper(s) can be reached. See Figure 62.</p>
---	---

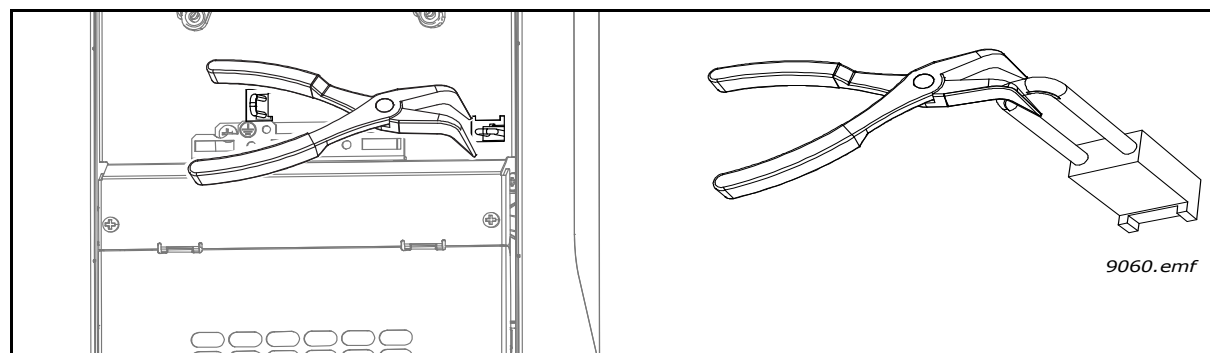

Figure 62. Removing the jumper, MR6 as example

7.3.2 FRAMES MR7 AND MR8

Follow the procedure described below to modify the EMC protection of the AC drive of frames MR7 and MR8 to EMC-level C4.

- | | |
|----------|---|
| 1 | Remove the main cover of the AC drive and locate the jumper. MR8 only: Push down the grounding arm. See Figure 63. |
|----------|---|

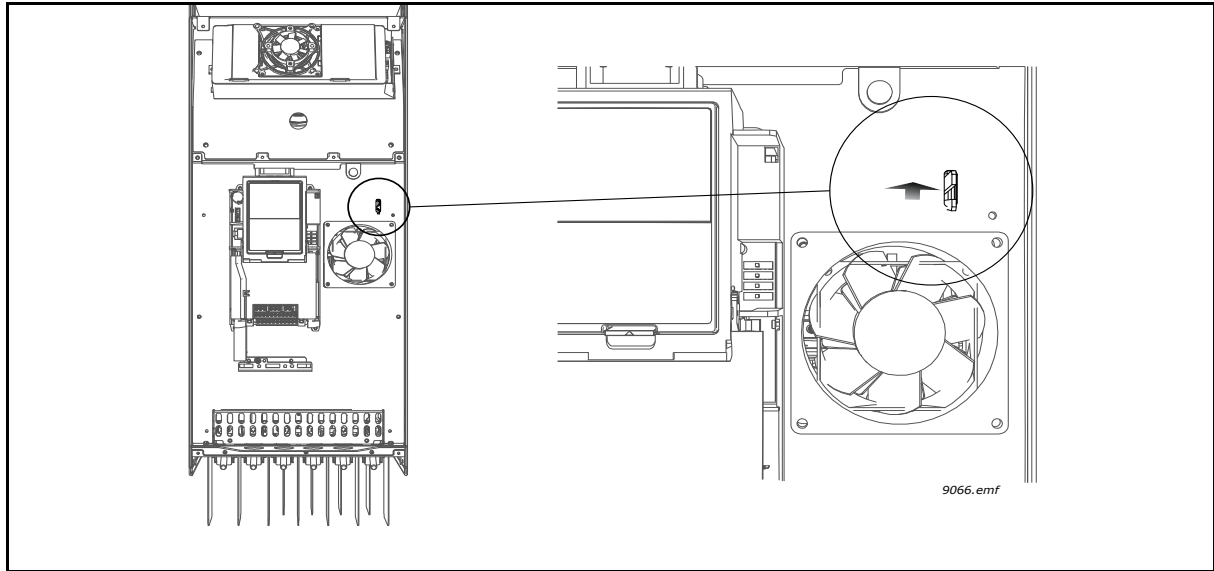

Figure 63. Grounding arm, MR8

- | | |
|----------|--|
| 2 | MR7 and MR8: Locate the EMC box under the cover. Remove the screws of the box cover to expose the EMC-jumper. Detach the jumper and re-fix the box cover. |
|----------|--|

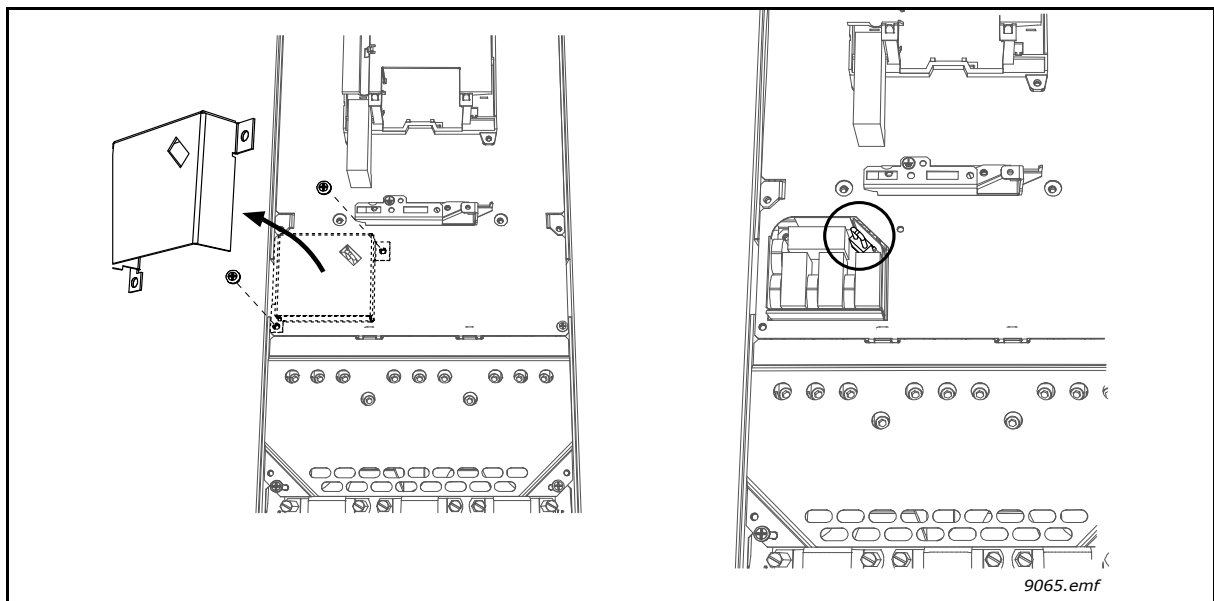

Figure 64. Detaching the EMC jumper, MR7-8

3 Additionally for MR7, locate the DC grounding busbar between connectors R- and U and detach the busbar from the frame by undoing the M4 screw.

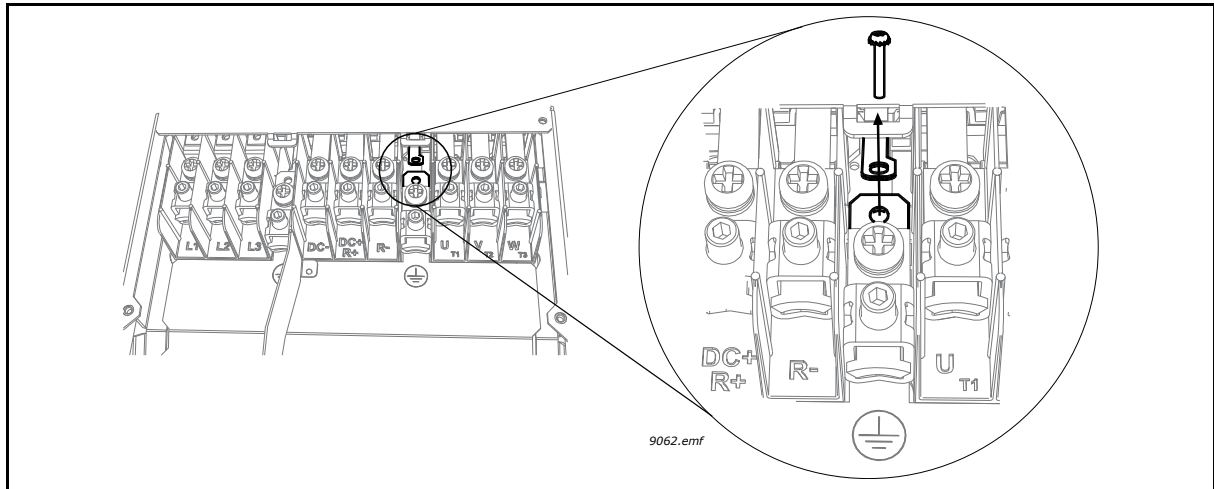

Figure 65. MR7: Detaching the DC grounding busbar from frame

7.3.3 FRAME MR9

Follow the procedure described below to modify the EMC protection of the AC drive of frame MR9 to EMC-level C4.

1 Find the connector in the accessories bag. Remove the main cover of the AC drive and locate the place for the connector next to the fan. Push the connector in its place. See Figure 66.

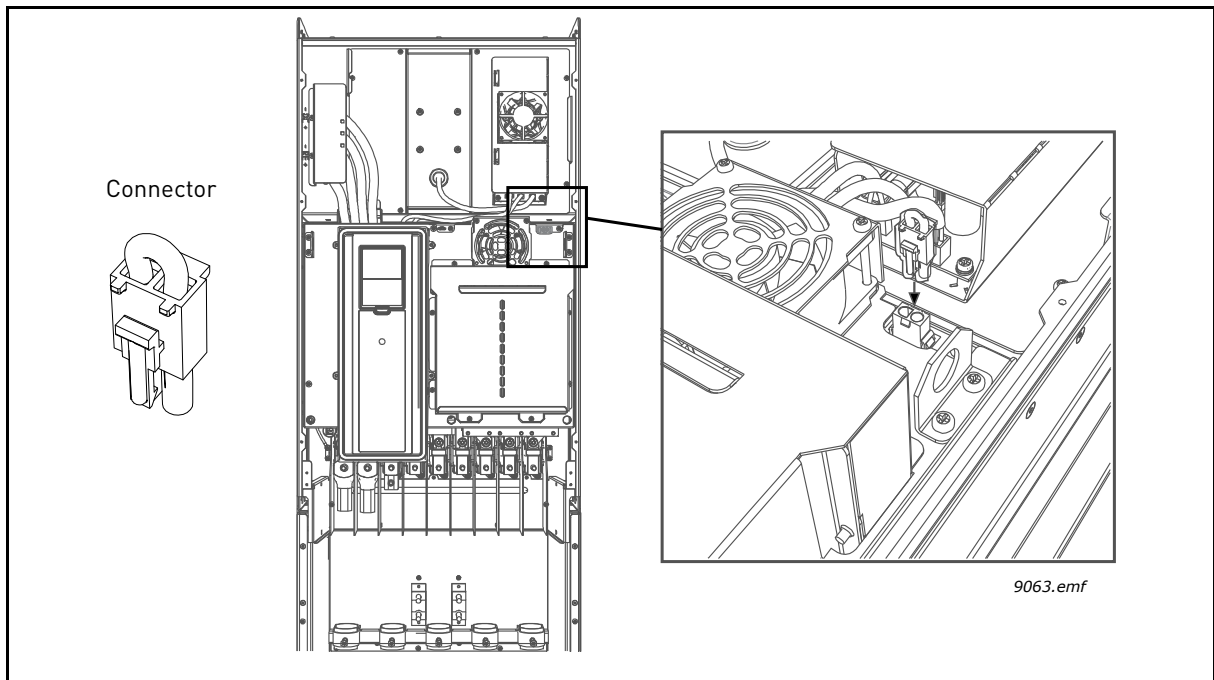

Figure 66. Placing the connector

2	Further remove the extension box cover, the touch shield and the I/O plate with I/O grommet plate. Locate the EMC jumper on the EMC board (see magnification below) and remove it.
----------	--

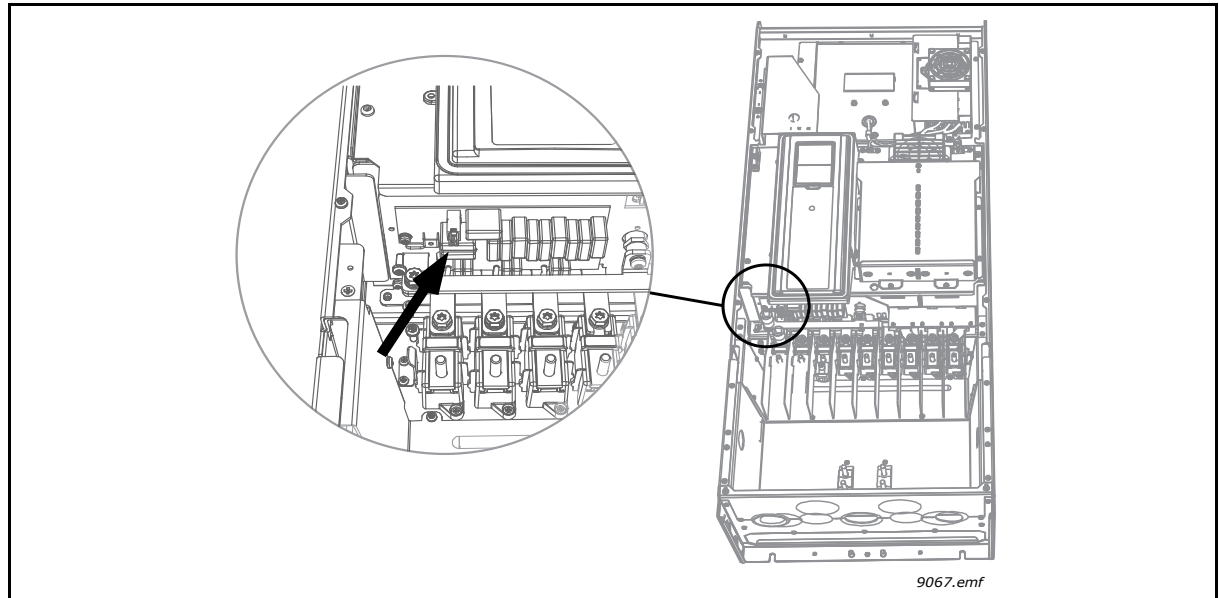

Figure 67. Removing the EMC jumper

	CAUTION! Before connecting the AC drive to mains make sure that the EMC protection class settings of the drive are appropriately made.
	NOTE! After having performed the change write 'EMC level modified' on the sticker included in the Vacon 100 delivery (see below) and note the date. Unless already done, attach the sticker close to the name plate of the AC drive.
	<div style="border: 1px solid black; border-radius: 10px; padding: 10px; width: fit-content; margin: 0 auto;"> <p style="text-align: center; margin: 0;">Product modified</p> <p style="text-align: right; margin: 0;">Date:</p> <p style="text-align: right; margin: 0;">Date:</p> <p style="text-align: right; margin: 0;">Date:DDMMYY </p> </div> <p style="text-align: right; margin-top: 5px;"><small>9005.emf</small></p>

7.4 MAINTENANCE

In normal conditions, the AC drive is maintenance-free. However, regular maintenance is recommended to ensure a trouble-free operation and a long lifetime of the drive. We recommend to follow the table below for maintenance intervals.

NOTE: Because of capacitor type (thin film capacitors), reforming of capacitors is not necessary.

Maintenance interval	Maintenance action
Regularly and according to general maintenance interval	<ul style="list-style-type: none"> • Check tightening torques of terminals • Check filters
6...24 months (depending on environment)	<ul style="list-style-type: none"> • Check input and output terminals and control I/O terminals. • Check operation of cooling fan • Check for corrosion on terminals, busbars and other surfaces • Check door filters in case of cabinet installation
24 months (depending on the environment)	<ul style="list-style-type: none"> • Clean heatsink and cooling tunnel
3...6 years	<ul style="list-style-type: none"> • Change internal IP54 fan
6...10 years	<ul style="list-style-type: none"> • Change main fan
10 years	<ul style="list-style-type: none"> • Replace the RTC battery

NOTE! See the service manual for information on cleaning tools.

8. TECHNICAL DATA, VACON 100

8.1 AC DRIVE POWER RATINGS

8.1.1 MAINS VOLTAGE 208-240 V

Table 24. Power ratings of Vacon 100, supply voltage 208-240 V

Mains voltage 208-240V, 50-60 Hz, 3~										
Drive type	Loadability					Motor shaft power				
	Low*		High*		Max current I _S 2s	230 V supply		230 V supply		
	Continuous current I _L [A]	10% over-load current [A]	Continuous current I _H [A]	50% over-load current [A]		10% over-load 40°C [kW]	50% over-load 50°C [kW]	10% over-load 40°C [hp]	50% over-load 50°C [hp]	
MR4	0003	3.7	4.1	2.6	3.9	5.2	0.55	0.37	0.75	0.5
	0004	4.8	5.3	3.7	5.6	7.4	0.75	0.55	1.0	0.75
	0007	6.6	7.3	4.8	7.2	9.6	1.1	0.75	1.5	1.0
	0008	8.0	8.8	6.6	9.9	13.2	1.5	1.1	2.0	1.5
	0011	11.0	12.1	8.0	12.0	16.0	2.2	1.5	3.0	2.0
	0012	12.5	13.8	9.6	16.5	19.6	3.0	2.2	4.0	3.0
MR5	0018	18.0	19.8	12.5	18.8	25.0	4.0	3.0	5.0	4.0
	0024	24.0	26.4	18.0	27.0	36.0	5.5	4.0	7.5	5.0
	0031	31.0	34.1	25.0	37.5	46.0	7.5	5.5	10.0	7.5
MR6	0048	48.0	52.8	31.0	46.5	62.0	11.0	7.5	15.0	10.0
	0062	62.0	68.2	48.0	72.0	96.0	15.0	11.0	20.0	15.0
MR7	0075	75.0	82.5	62.0	93.0	124.0	18.5	15.0	25.0	20.0
	0088	88.0	96.8	75.0	112.5	150.0	22.0	18.5	30.0	25.0
	0105	105.0	115.5	88.0	132.0	176.0	30.0	22.0	40.0	30.0
MR8	0140	143.0	154.0	114.0	171.0	210.0	37.0	30.0	50.0	40.0
	0170	170.0	187.0	140.0	210.0	280.0	45.0	37.0	60.0	50.0
	0205	208.0	225.5	170.0	255.0	340.0	55.0	45.0	75.0	60.0
MR9	0261	261.0	287.1	211.0	316.5	410.0	75.0	55.0	100.0	75.0
	0310	310.0	341.0	251.0	376.5	502.0	90.0	75.0	125.0	100.0

* See Chapter 8.1.3.

NOTE! The rated currents in given ambient temperatures (in Table 28) are achieved only when the switching frequency is equal to or less than the factory default.

NOTE! For cyclical loads such as e.g. lifts and winches, please contact Vacon for dimensioning.

8.1.2 MAINS VOLTAGE 380-500 V

Table 25. Power ratings of Vacon 100, supply voltage 380-500 V

Mains voltage 380-500V, 50-60 Hz, 3~										
Drive type	Loadability					Motor shaft power				
	Low*		High*		Max current I _S 2s	400 V supply		480 V supply		
	Continuous current I _L [A]	10% overload current [A]	Continuous current I _H [A]	50% overload current [A]		10% overload 40°C [kW]	50% overload 50°C [kW]	10% overload 40°C [hp]	50% overload 50°C [hp]	
MR4	0003	3.4	3.7	2.6	3.9	5.2	1.1	0.75	1.5	1.0
	0004	4.8	5.3	3.4	5.1	6.8	1.5	1.1	2.0	1.5
	0005	5.6	6.2	4.3	6.5	8.6	2.2	1.5	3.0	2.0
	0008	8.0	8.8	5.6	8.4	11.2	3.0	2.2	4.0	3.0
	0009	9.6	10.6	8.0	12.0	16.0	4.0	3.0	5.0	4.0
MR5	0012	12.0	13.2	9.6	14.4	19.2	5.5	4.0	7.5	5.0
	0016	16.0	17.6	12.0	18.0	24.0	7.5	5.5	10.0	7.5
	0023	23.0	25.3	16.0	24.0	32.0	11.0	7.5	15.0	10.0
MR6	0031	31.0	34.1	23.0	34.5	46.0	15.0	11.0	20.0	15.0
	0038	38.0	41.8	31.0	46.5	62.0	18.5	15.0	25.0	20.0
	0046	46.0	50.6	38.0	57.0	76.0	22.0	18.5	30.0	25.0
MR7	0061	61.0	67.1	46.0	69.0	92.0	30.0	22.0	40.0	30.0
	0072	72.0	79.2	61.0	91.5	122.0	37.0	30.0	50.0	40.0
	0087	87.0	95.7	72.0	108.0	144.0	45.0	37.0	60.0	50.0
MR8	0105	105.0	115.5	87.0	130.5	174.0	55.0	45.0	75.0	60.0
	0140	140.0	154.0	105.0	157.5	210.0	75.0	55.0	100.0	75.0
	0170	170.0	187.0	140.0	210.0	280.0	90.0	75.0	125.0	100.0
MR9	0205	205.0	225.5	170.0	255.0	340.0	110.0	90.0	150.0	125.0
	0261	261.0	287.1	205.0	307.5	410.0	132.0	110.0	200.0	150.0
	0310	310.0	341.0	251.0	376.5	502.0	160.0	132.0	250.0	200.0

* See Chapter 8.1.3.

NOTE! The rated currents in given ambient temperatures (in Table 28) are achieved only when the switching frequency is equal to or less than the factory default.

NOTE! For cyclical loads such as e.g. lifts and winches, please contact Vacon for dimensioning.

8.1.3 DEFINITIONS OF OVERLOADABILITY

Low overload = Following continuous operation at rated output current, 110% rated output current (I_L) for 1 min, followed by a period of load current less than rated current, and of such duration that the r.m.s output current, over the duty cycle, does not exceed rated output current (I_L).

Example: If the duty cycle requires 110% rated current for 1 min in every 10min, the remaining 9 min must be at approximately 98% rated current or less to maintain an r.m.s value $\geq 100\%$.

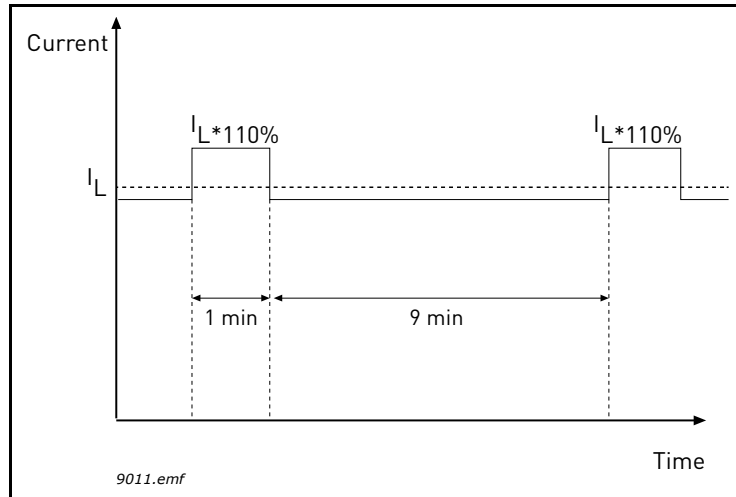

Figure 68. Low overload

High overload = Following continuous operation at rated output current, 150 % rated output current (I_H) for 1 min, followed by a period of load current less than rated current, and of such duration that the r.m.s output current, over the duty cycle, does not exceed rated output current (I_H).

Example: If the duty cycle requires 150% rated current for 1 min in every 10 min, the remaining 9 min must be at approximately 92% rated current or less to maintain an r.m.s value $\geq 100\%$.

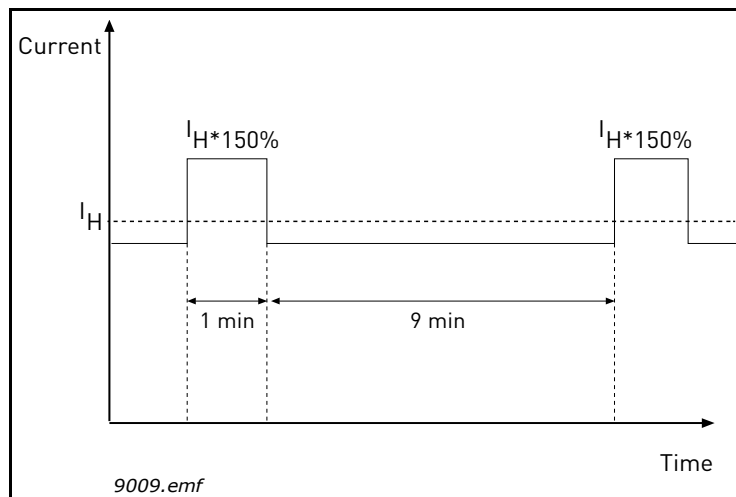

Figure 69. High overload

NOTE! For more information, please refer to IEC61800-2 (IEC:1998) Standard.

8.1.4 BRAKE RESISTOR RATINGS

Make sure that the resistance is higher than the minimum resistance defined. The power handling capacity must be sufficient for the application.

Recommended brake resistor types and calculated resistances for Vacon 100 AC drives:

Frame	Duty cycle	Type of brake resistor	Resistance [ohm]
MR4	Light duty*	BRR 0022 LD 5	63.0
	Heavy duty*	BRR 0022 HD 5	63.0
MR5	Light duty	BRR 0031 LD 5	41.0
	Heavy duty	BRR 0031 HD 5	41.0
MR6	Light duty	BRR 0045 LD 5	21.0
	Heavy duty	BRR 0045 HD 5	21.0
MR7	Light duty	BRR 0061 LD 5	14.0
	Heavy duty	BRR 0061 HD 5	14.0
MR8	Light duty	BRR 0105 LD 5	6.5
	Heavy duty	BRR 0105 HD 5	6.5
MR9	Light duty	BRR 0300 LD 5	3.3
	Heavy duty	BRR 0300 HD 5	3.3

* **Light duty** cycle for brake resistor cyclic use (one LD pulse within 120-second period). The light duty resistor is rated for a 5-second ramp from full power to zero; **Heavy duty** cycle for brake resistor cyclic use (one HD pulse within 120-second period). The heavy duty resistor is rated for a 3-second full power braking with a 7-second ramp to zero.

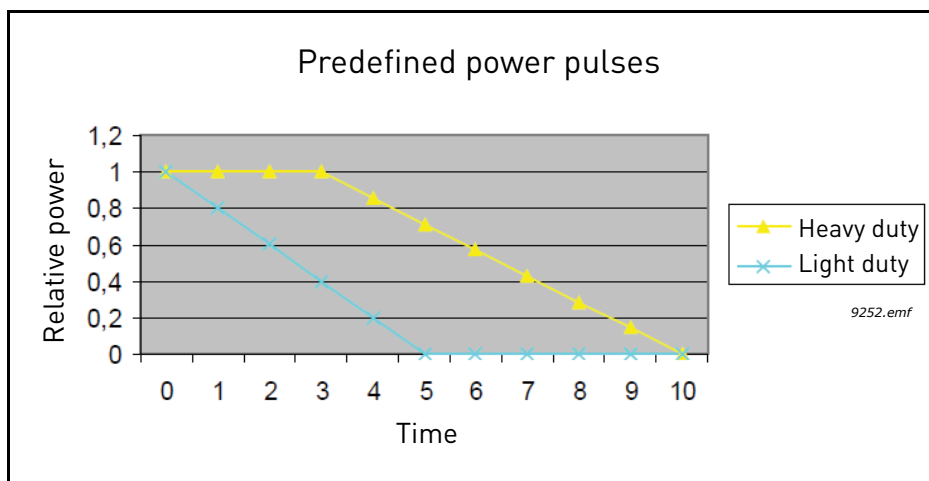

Figure 70. LD and HD pulse shapes

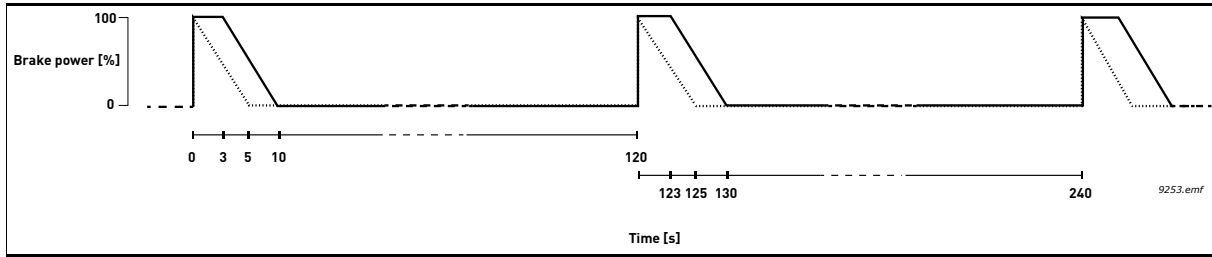

Figure 71. Duty cycles of LD and HD pulses

Table 26. Minimum resistance value and braking power with recommended resistor types, mains voltage 208-240V

Mains voltage 208-240 V, 50/60 Hz, 3~		
Frame	Brake min. resistance [ohm]	Brake power* @405 Vdc [kW]
MR4	30.0	2.6
MR5	20.0	3.9
MR6	10.0	7.8
MR7	5.5	11.7
MR8	3.0	25.2
MR9	1.4	49.7

* With recommended resistor types

Table 27. Minimum resistance value and braking power with recommended resistor types, mains voltage 380-500V

Mains voltage 380-500 V, 50/60 Hz, 3~		
Type	Brake min. resistance [ohm]	Brake power* @845 Vdc [kW]
MR4	63.0	11.3
MR5	41.0	17.0
MR6	21.0	34.0
MR7	14.0	51.0
MR8	6.5	109.9
MR9	3.3	216.4

* With recommended resistor types

8.2 VACON 100 - TECHNICAL DATA

Table 28. Vacon 100 technical data

Mains connection	Input voltage U_{in}	208...240 V; 380...500 V; -10%...+10%
	Input frequency	50...60 Hz -5...+10%
	Connection to mains	Once per minute or less
	Starting delay	6 s (MR4 to MR6); 8 s (MR7 to MR9)
Motor connection	Output voltage	$0-U_{in}$
	Continuous output current	I_L : Ambient temperature max. +40 °C overload $1.1 \times I_L$ (1 min./10 min) I_H : Ambient temperature max. +50 °C overload $1.5 \times I_H$ (1 min./10 min)
	Output frequency	0...320 Hz (standard)
	Frequency resolution	0.01 Hz
Control characteristics	Switching frequency (see parameter P3.1.2.3)	MR4-6: 1.5...10 kHz; Defaults: MR4-6: 6 kHz (except 0012 2, 0031 2, 0062 2, 0012 5, 0031 5 and 0061 5: 4 kHz) MR7-9: 1.5...6 kHz; Defaults: MR7: 4 kHz MR8: 3 kHz MR9: 2 kHz Automatic switching frequency derating in case of overload.
	Frequency reference	
	Analogue input	Resolution 0.1% (10-bit), accuracy $\pm 1\%$
	Panel reference	Resolution 0.01 Hz
	Field weakening point	8...320 Hz
	Acceleration time	0.1...3000 sec
	Deceleration time	0.1...3000 sec

Table 28. Vacon 100 technical data

Ambient conditions	Ambient operating temperature	I _L current: -10°C (no frost)...+40 °C I _H current: -10°C (no frost)...+50 °C Max. operating temperature: +50 °C
	Storage temperature	-40 °C...+70 °C
	Relative humidity	0...95% R _H , non-condensing, non-corrosive
	Air quality: • chemical vapours • mechanical particles	Tested according to IEC 60068-2-60 Test Ke: Flowing mixed gas corrosion test, Method 1 (H ₂ S [hydrogen sulfide] and SO ₂ [sulfur dioxide]) Designed according to: IEC 60721-3-3, unit in operation, class 3C3 (IP21/UL Type 1 Models 3C2) IEC 60721-3-3, unit in operation, class 3S2
Ambient conditions (cont.)	Altitude	100% load capacity (no derating) up to 1,000 m 1-% derating for each 100m above 1,000 m <u>Max. altitudes:</u> 208...240 V: 4,000 m (TN and IT systems) 380...500 V: 4,000 m (TN and IT systems) <u>Voltage for relay outputs:</u> Up to 3,000 m : Allowed up to 240 V 3,000 m...4,000 m: Allowed up to 120 V <u>Corner-grounding:</u> up to 2,000 m only (see Chapter 5.4.)
	Vibration EN61800-5-1/ EN60068-2-6	5...150 Hz Displacement amplitude 1 mm (peak) at 5...15.8 Hz (MR4...MR9) Max acceleration amplitude 1 G at 15.8...150 Hz (MR4...MR9)
	Shock EN61800-5-1 EN60068-2-27	UPS Drop Test (for applicable UPS weights) Storage and shipping: max 15 G, 11 ms (in package)
	Enclosure class	IP21/Type 1 standard in entire kW/HP range IP54/Type 12 option NOTE! Keypad or panel adapter required for IP54/Type 12
EMC (at default settings)	Immunity	Fulfils EN61800-3 (2004), first and second environment
	Emissions	+EMC2: EN61800-3 (2004), Category C2 The drive can be modified for IT-networks. See Chapter 7.3 on page 78.
Noise level	Average noise level (min...max) sound pressure level in dB(A)	MR4: 45...56 MR7: 43...73 MR5: 57...65 MR8: 58...73 MR6: 63...72 MR9: 54...75 Sound pressure depends on the cooling fan speed which is controlled in accordance with the drive temperature.
Safety		EN 61800-5-1 (2007), CE; (see unit name-plate for more detailed approvals)

Table 28. Vacon 100 technical data

Protections	Overvoltage trip limit	240-volt drives: 456 VDC 500-volt drives: 911 VDC
	Undervoltage trip limit	Depends on supply voltage (0,8775*supply voltage): Supply voltage 240 V: Trip limit 211 VDC Supply voltage 400 V: Trip limit 351 VDC Supply voltage 500 V: Trip limit 421 VDC
	Earth fault protection	Yes
	Mains supervision	Yes
	Motor phase supervision	Yes
	Overcurrent protection	Yes
	Unit overtemperature protection	Yes
	Motor overload protection	Yes
	Motor stall protection	Yes
	Motor underload protection	Yes
Short-circuit protection of +24 V and +10 V reference voltages	Yes	



8.2.1 TECHNICAL INFORMATION ON CONTROL CONNECTIONS

Table 29. Technical information on standard I/O board

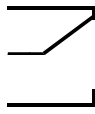
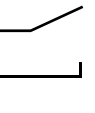
Standard I/O board		
Terminal	Signal	Technical information
1	Reference output	+10 V, +3%; Maximum current 10 mA
2	Analogue input, voltage or current	Analogue input channel 1 0- +10 V (Ri = 200 kΩ) 4-20 mA (Ri =250 Ω) Resolution 0.1 %, accuracy ±1 % Selection V/mA with dip-switches (see page 63) Short-circuited protected.
3	Analogue input common (current)	Differential input if not connected to ground; Allows ±20 V differential mode voltage to GND
4	Analogue input, voltage or current	Analogue input channel 2 Default: 4-20 mA (Ri =250 Ω) 0-10 V (Ri=200kΩ) Resolution 0.1 %, accuracy ±1 % Selection V/mA with dip-switches (see page 63) Short-circuited protected.
5	Analogue input common (current)	Differential input if not connected to ground; Allows 20V differential mode voltage to GND
6	24 V aux. voltage	+24 V, ±10%, max volt. ripple < 100 mVrms; max. 250 mA Short-circuit protected.
7	I/O ground	Ground for reference and controls (connected internally to frame earth through 1 MΩ)
8	Digital input 1	Positive or negative logic Ri = min. 5 kΩ 0...5 V = "0" 15...30 V = "1"
9	Digital input 2	
10	Digital input 3	
11	Common A for DIN1-DIN6	Digital inputs can be disconnected from ground, see Chapter 6.1.2.2.
12	24 V aux. voltage	+24 V, ±10%, max volt. ripple < 100mVrms; max. 250 mA Short-circuit protected
13	I/O ground	Ground for reference and controls (connected internally to frame earth through 1 MΩ)
14	Digital input 4	Positive or negative logic Ri = min. 5 kΩ 0...5 V = "0" 15...30 V = "1"
15	Digital input 5	
16	Digital input 6	
17	Common A for DIN1-DIN6	Digital inputs can be isolated from ground, see Chapter 6.1.2.2.
18	Analogue signal (+output)	Analogue output channel 1, selection 0 -20 mA, load <500 Ω Default: 0-20 mA 0-10 V Resolution 0.1 %, accuracy ±2 % Selection V/mA with dip-switches (see page 63) Short-circuited protected.
19	Analogue output common	
30	24V auxiliary input voltage	Can be used as external power backup for the control unit.
A	RS485	Differential receiver/transmitter Set bus termination with dip switches (see page 63). Termination resistance = 220 ohm.
B	RS485	

Standard relay board (+SBF3)		
Terminal	Signal	Technical information
21	 Relay output 1*	Change-over contact (SPDT) relay. 5,5 mm isolation between channels. Switching capacity 24 VDC/8 A 250 VAC/8 A 125 VDC/0.4 A Min.switching load 5 V/10 mA
22		
23		
24	 Relay output 2*	Change-over contact (SPDT) relay. 5,5 mm isolation between channels. Switching capacity 24 VDC/8 A 250 VAC/8 A 125 VDC/0.4 A Min.switching load 5 V/10 mA
25		
26		
32	 Relay output 3*	Normally-open (NO or SPST) contact relay. 5,5 mm isolation between channels. Switching capacity 24 VDC/8 A 250 VAC/8 A 125 VDC/0.4 A Min.switching load 5 V/10 mA
33		

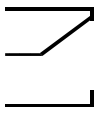
* If 230 VAC is used as control voltage from the output relays, the control circuitry must be powered with a separate isolation transformer to limit short circuit current and overvoltage spikes. This is to prevent welding on the relay contacts. Refer to standard EN 60204-1, section 7.2.9.

Optional relay board (+SBF4)		
Terminal	Signal	Technical information
21	 Relay output 1*	Change-over contact (SPDT) relay. 5,5 mm isolation between channels. Switching capacity 24 VDC/8 A 250 VAC/8 A 125 VDC/0.4 A Min.switching load 5 V/10 mA
22		
23		
24	 Relay output 2*	Change-over contact (SPDT) relay. 5,5 mm isolation between channels. Switching capacity 24 VDC/8 A 250 VAC/8 A 125 VDC/0.4 A Min.switching load 5 V/10 mA
25		
26		
28	T11+	Thermistor input. Rtrip = 4.7 kΩ (PTC); Measuring voltage 3.5V
29	T11-	

* If 230 VAC is used as control voltage from the output relays, the control circuitry must be powered with a separate isolation transformer to limit short circuit current and overvoltage spikes. This is to prevent welding on the relay contacts. Refer to standard EN 60204-1, section 7.2.9.

9. TECHNICAL DATA, VACON 100 FLOW

9.1 AC DRIVE POWER RATINGS

9.1.1 MAINS VOLTAGE 208-240 V

Table 30. Power ratings of Vacon 100 FLOW, supply voltage 208-240 V

Mains voltage 208-240 V, 50-60 Hz, 3~						
Drive type	*Loadability			Motor shaft power		
	Continuous current I_L [A]	10% overload current [A]	Max current I_S 2s	230 V supply	230 V supply	
				10% overload 40 °C [kW]	10% overload 40 °C [hp]	
MR4	0003	3.7	4.1	5.2	0.55	0.75
	0004	4.8	5.3	7.4	0.75	1.0
	0007	6.6	7.3	9.6	1.1	1.5
	0008	8.0	8.8	13.2	1.5	2.0
	0011	11.0	12.1	16.0	2.2	3.0
MR5	0012	12.5	13.8	19.6	3.0	4.0
	0018	18.0	19.8	25.0	4.0	5.0
	0024	24.0	26.4	36.0	5.5	7.5
MR6	0031	31.0	34.1	46.0	7.5	10.0
	0048	48.0	52.8	62.0	11.0	15.0
MR7	0062	62.0	68.2	96.0	15.0	20.0
	0075	75.0	82.5	124.0	18.5	25.0
	0088	88.0	96.8	150.0	22.0	30.0
MR8	0105	105.0	115.5	176.0	30.0	40.0
	0140	143.0	154.0	210.0	37.0	50.0
	0170	170.0	187.0	280.0	45.0	60.0
MR9	0205	208.0	225.5	340.0	55.0	75.0
	0261	261.0	287.1	410.0	75.0	100.0
	0310	310.0	341.0	502.0	90.0	125.0

* See Chapter 9.1.3.

NOTE! The rated currents in given ambient temperatures (in Table 32) are achieved only when the switching frequency is equal to or less than the factory default.

NOTE! For cyclical loads, please contact Vacon for dimensioning.

9.1.2 MAINS VOLTAGE 380-500 V

Table 31. Power ratings of Vacon 100 FLOW, supply voltage 380-500 V

Mains voltage 380-500V, 50-60 Hz, 3~						
Drive type	*Loadability			Motor shaft power		
	Continuous current I_L [A]	10% overload current [A]	Max current I_S 2s	400 V supply	480 V supply	
				10% overload 40 °C [kW]	10% overload 40 °C [hp]	
MR4	0003	3.4	3.7	5.2	1.1	1.5
	0004	4.8	5.3	6.8	1.5	2.0
	0005	5.6	6.2	8.6	2.2	3.0
	0008	8.0	8.8	11.2	3.0	4.0
	0009	9.6	10.6	16.0	4.0	5.0
MR5	0012	12.0	13.2	19.2	5.5	7.5
	0016	16.0	17.6	24.0	7.5	10.0
	0023	23.0	25.3	32.0	11.0	15.0
MR6	0031	31.0	34.1	46.0	15.0	20.0
	0038	38.0	41.8	62.0	18.5	25.0
	0046	46.0	50.6	76.0	22.0	30.0
MR7	0061	61.0	67.1	92.0	30.0	40.0
	0072	72.0	79.2	122.0	37.0	50.0
	0087	87.0	95.7	144.0	45.0	60.0
MR8	0105	105.0	115.5	174.0	55.0	75.0
	0140	140.0	154.0	210.0	75.0	100.0
	0170	170.0	187.0	280.0	90.0	125.0
MR9	0205	205.0	225.5	340.0	110.0	150.0
	0261	261.0	287.1	410.0	132.0	200.0
	0310	310.0	341.0	502.0	160.0	250.0

* See Chapter 9.1.3.

NOTE! The rated currents in given ambient temperatures (in Table 32) are achieved only when the switching frequency is equal to or less than the factory default.

NOTE! For cyclical loads, please contact Vacon for dimensioning.

9.1.3 DEFINITIONS OF OVERLOADABILITY

Low overload = Following continuous operation at rated output current, 110% rated output current (I_L) for 1 min, followed by a period of load current less than rated current, and of such duration that the r.m.s output current, over the duty cycle, does not exceed rated output current (I_L).

Example: If the duty cycle requires 110% rated current for 1 min in every 10min, the remaining 9 min must be at approximately 98% rated current or less to maintain an r.m.s value $\geq 100\%$.

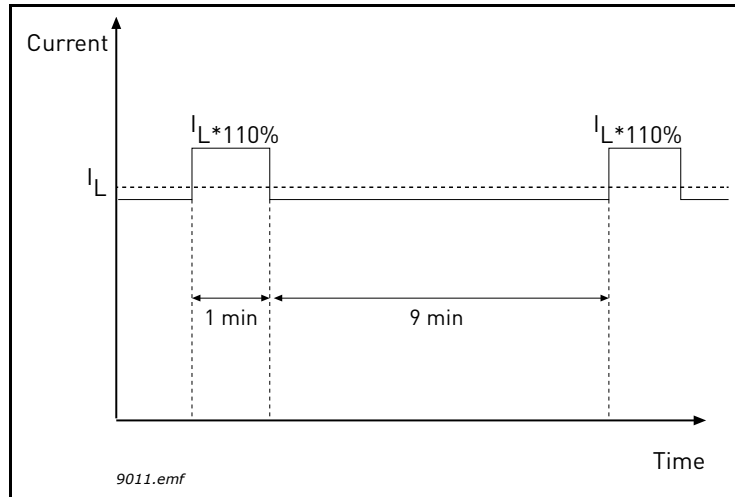

Figure 72. Low overload

NOTE! For more information, please refer to IEC61800-2 (IEC:1998) Standard.

9.2 VACON 100 FLOW - TECHNICAL DATA

Table 32. Vacon 100 FLOW technical data

Mains connection	Input voltage U_{in}	208...240 V; 380...500 V; -10%...+10%
	Input frequency	50...60 Hz -5...+10%
	Connection to mains	Once per minute or less
	Starting delay	6 s (MR4 to MR6); 8 s (MR7 to MR9)
Motor connection	Output voltage	0- U_{in}
	Continuous output current	I_L : Ambient temperature max. +40 °C overload 1.1 x I_L (1 min./10 min)
	Output frequency	0...320 Hz (standard)
	Frequency resolution	0.01 Hz
Control characteristics	Switching frequency (see parameter P3.1.2.3)	MR4-6: 1.5...10 kHz; Defaults: MR4-6: 6 kHz (except 0012 2, 0031 2, 0062 2, 0012 5, 0031 5 and 0061 5: 4 kHz) MR7-9: 1.5...6 kHz; Defaults: MR7: 4 kHz MR8: 3 kHz MR9: 2 kHz Automatic switching frequency derating in case of overload.
	<u>Frequency reference</u>	
	Analogue input	Resolution 0.1% (10-bit), accuracy ±1%
	Panel reference	Resolution 0.01 Hz
	Field weakening point	8...320 Hz
	Acceleration time	0.1...3000 sec
Deceleration time	0.1...3000 sec	

Table 32. Vacon 100 FLOW technical data

Ambient conditions	Ambient operating temperature	I _L current: -10 °C (no frost)...+40 °C Up to 50 °C with derating (1,5%/1°C)
	Storage temperature	-40 °C...+70 °C
	Relative humidity	0...95% R _H , non-condensing, non-corrosive
	Air quality: • chemical vapours • mechanical particles	Tested according to IEC 60068-2-60 Test Ke: Flowing mixed gas corrosion test, Method 1 (H ₂ S [hydrogen sulfide] and SO ₂ [sulfur dioxide]) Designed according to: IEC 60721-3-3, unit in operation, class 3C3 (IP21/UL Type 1 Models 3C2) IEC 60721-3-3, unit in operation, class 3S2
Ambient conditions (cont.)	Altitude	100% load capacity (no derating) up to 1,000 m 1-% derating for each 100m above 1,000 m <u>Max. altitudes:</u> 208...240 V: 4,000 m (TN and IT systems) 380...500 V: 4,000 m (TN and IT systems) <u>Voltage for relay outputs:</u> Up to 3,000 m : Allowed up to 240 V 3,000 m...4,000 m: Allowed up to 120 V <u>Corner-grounding:</u> up to 2,000 m only (see Chapter 5.4.)
	Vibration EN61800-5-1/ EN60068-2-6	5...150 Hz Displacement amplitude 1 mm (peak) at 5...15.8 Hz (MR4...MR9) Max acceleration amplitude 1 G at 15.8...150 Hz (MR4...MR9)
	Shock EN61800-5-1 EN60068-2-27	UPS Drop Test (for applicable UPS weights) Storage and shipping: max 15 G, 11 ms (in package)
	Enclosure class	IP21/Type 1 standard in entire kW/HP range IP54/Type 12 option NOTE! Keypad or panel adapter required for IP54/Type 12
EMC (at default settings)	Immunity	Fulfills EN61800-3 (2004), first and second environment
	Emissions	+EMC2: EN61800-3 (2004), Category C2 The drive can be modified for IT-networks. See Chapter 7.3 on page 78.
Noise level	Average noise level (min...max) sound pressure level in dB(A)	MR4: 45...56 MR7: 43...73 MR5: 57...65 MR8: 58...73 MR6: 63...72 MR9: 54...75 Sound pressure depends on the cooling fan speed which is controlled in accordance with the drive temperature.
Safety		EN 61800-5-1 (2007), CE; (see unit name-plate for more detailed approvals)

Table 32. Vacon 100 FLOW technical data

Protections	Overvoltage trip limit	240-volt drives: 456 VDC 500-volt drives: 911 VDC
	Undervoltage trip limit	Depends on supply voltage (0,8775*supply voltage): Supply voltage 240 V: Trip limit 211 VDC Supply voltage 400 V: Trip limit 351 VDC Supply voltage 500 V: Trip limit 421 VDC
	Earth fault protection	Yes
	Mains supervision	Yes
	Motor phase supervision	Yes
	Overcurrent protection	Yes
	Unit overtemperature protection	Yes
	Motor overload protection	Yes
	Motor stall protection	Yes
	Motor underload protection	Yes
	Short-circuit protection of +24 V and +10 V reference voltages	Yes



9.2.1 TECHNICAL INFORMATION ON CONTROL CONNECTIONS

Table 33. Technical information on standard I/O board

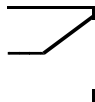
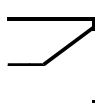
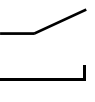
Standard I/O board		
Terminal	Signal	Technical information
1	Reference output	+10 V, +3%; Maximum current 10 mA
2	Analogue input, voltage or current	Analogue input channel 1 0- +10 V (Ri = 200 kΩ) 4-20 mA (Ri =250 Ω) Resolution 0.1 %, accuracy ±1 % Selection V/mA with dip-switches (see page 63) Short-circuited protected.
3	Analogue input common (current)	Differential input if not connected to ground; Allows ±20 V differential mode voltage to GND
4	Analogue input, voltage or current	Analogue input channel 2 Default: 4-20 mA (Ri =250 Ω) 0-10 V (Ri=200kΩ) Resolution 0.1 %, accuracy ±1 % Selection V/mA with dip-switches (see page 63) Short-circuited protected.
5	Analogue input common (current)	Differential input if not connected to ground; Allows 20V differential mode voltage to GND
6	24 V aux. voltage	+24 V, ±10%, max volt. ripple < 100 mVrms; max. 250 mA Short-circuit protected.
7	I/O ground	Ground for reference and controls (connected internally to frame earth through 1 MΩ)
8	Digital input 1	Positive or negative logic Ri = min. 5 kΩ 0...5 V = "0" 15...30 V = "1"
9	Digital input 2	
10	Digital input 3	
11	Common A for DIN1-DIN6	Digital inputs can be disconnected from ground, see Chapter 6.1.2.2.
12	24 V aux. voltage	+24 V, ±10%, max volt. ripple < 100mVrms; max. 250 mA Short-circuit protected
13	I/O ground	Ground for reference and controls (connected internally to frame earth through 1 MΩ)
14	Digital input 4	Positive or negative logic Ri = min. 5 kΩ 0...5 V = "0" 15...30 V = "1"
15	Digital input 5	
16	Digital input 6	
17	Common A for DIN1-DIN6	Digital inputs can be isolated from ground, see Chapter 6.1.2.2.
18	Analogue signal (+output)	Analogue output channel 1, selection 0 -20 mA, load <500 Ω Default: 0-20 mA 0-10 V Resolution 0.1 %, accuracy ±2 % Selection V/mA with dip-switches (see page 63) Short-circuited protected.
19	Analogue output common	
30	24V auxiliary input voltage	Can be used as external power backup for the control unit.
A	RS485	Differential receiver/transmitter Set bus termination with dip switches (see page 63). Termination resistance = 220 ohm.
B	RS485	

Standard relay board (+SBF3)		
Terminal	Signal	Technical information
21	 Relay output 1*	Change-over contact (SPDT) relay. 5,5 mm isolation between channels. Switching capacity 24 VDC/8 A 250 VAC/8 A 125 VDC/0.4 A Min.switching load 5 V/10 mA
22		
23		
24	 Relay output 2*	Change-over contact (SPDT) relay. 5,5 mm isolation between channels. Switching capacity 24 VDC/8 A 250 VAC/8 A 125 VDC/0.4 A Min.switching load 5 V/10 mA
25		
26		
32	 Relay output 3*	Normally-open (NO or SPST) contact relay. 5,5 mm isolation between channels. Switching capacity 24 VDC/8 A 250 VAC/8 A 125 VDC/0.4 A Min.switching load 5 V/10 mA
33		

* If 230 VAC is used as control voltage from the output relays, the control circuitry must be powered with a separate isolation transformer to limit short circuit current and overvoltage spikes. This is to prevent welding on the relay contacts. Refer to standard EN 60204-1, section 7.2.9.

Optional relay board (+SBF4)		
Terminal	Signal	Technical information
21	 Relay output 1*	Change-over contact (SPDT) relay. 5,5 mm isolation between channels. Switching capacity 24 VDC/8 A 250 VAC/8 A 125 VDC/0.4 A Min.switching load 5 V/10 mA
22		
23		
24	 Relay output 2*	Change-over contact (SPDT) relay. 5,5 mm isolation between channels. Switching capacity 24 VDC/8 A 250 VAC/8 A 125 VDC/0.4 A Min.switching load 5 V/10 mA
25		
26		
28	T11+	Thermistor input. Rtrip = 4.7 kΩ (PTC); Measuring voltage 3.5V
29	T11-	

* If 230 VAC is used as control voltage from the output relays, the control circuitry must be powered with a separate isolation transformer to limit short circuit current and overvoltage spikes. This is to prevent welding on the relay contacts. Refer to standard EN 60204-1, section 7.2.9.

VACON[®]

DRIVEN BY DRIVES

Find your nearest Vacon office
on the Internet at:

www.vacon.com



Document ID:



D P D 0 0 8 7 3 D

Manual authoring:
documentation@vacon.com

Vacon Plc.
Runsorintie 7
65380 Vaasa
Finland

Order code:



D O C - I N S 0 4 1 2 3 + D L U K

Subject to change without prior notice
© 2012 Vacon Plc.

Rev. D