

**VACON 100**  
AC DRIVES

# APPLICATION MANUAL

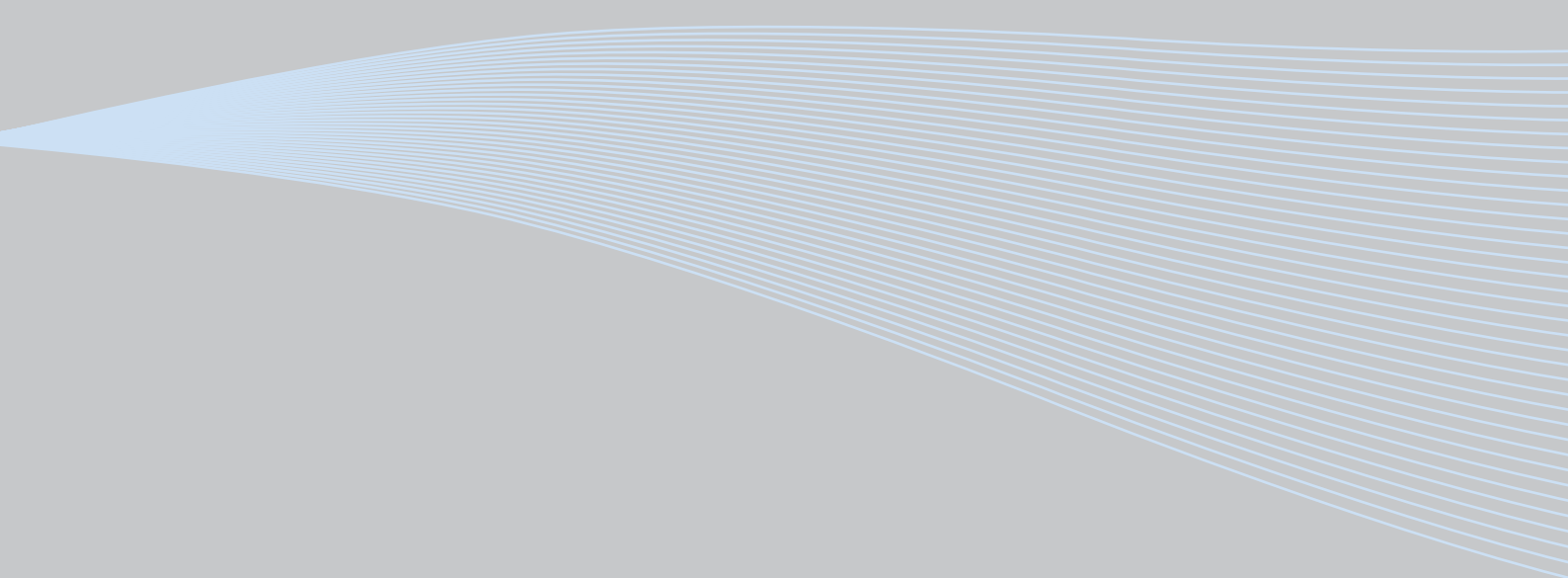



# INDEX

Document: DPD00927D

Version release date: 5.5.12

Corresponds to software package FW0072V003.vcx

<b>1. Vacon 100 - Startup .....</b>	<b>2</b>
1.1 Startup Wizard.....	2
1.2 I/O Configuration Wizard .....	4
1.2.1 Standard I/O Configuration .....	5
1.2.2 Local-Remote I/O Configuration .....	6
1.2.3 PID Control I/O Configuration .....	7
1.3 PID Mini-Wizard .....	8
1.4 Multi-pump mini-wizard .....	9
1.5 Fire mode wizard.....	10
<b>2. Keypad of the drive .....</b>	<b>11</b>
2.1 Buttons .....	11
2.2 Display .....	11
2.3 Navigation on keypad .....	11
2.4 Vacon graphical keypad .....	13
2.4.1 Using the graphical keypad.....	13
2.5 Vacon text keypad.....	20
2.5.1 Keypad display.....	20
2.5.2 Using the text keypad .....	21
2.6 Menu structure.....	24
2.6.1 Quick setup.....	25
2.6.2 Monitor .....	25
2.6.3 Parameters.....	27
2.6.4 Diagnostics .....	27
2.6.5 I/O and hardware.....	30
2.6.6 User settings .....	35
2.6.7 Favorites .....	36
2.6.8 User levels.....	36
<b>3. Vacon 100 Application.....</b>	<b>38</b>
3.1 Specific functions of Vacon AC drive.....	38
3.2 Control connections, factory settings .....	39
3.3 Quick setup parameter group .....	40
3.4 Monitor group.....	42
3.4.1 Multimonitor .....	42
3.4.2 Trend curve .....	42
3.4.3 Basic .....	44
3.4.4 I/O .....	45
3.4.5 Temperature inputs .....	45
3.4.6 Extras & advanced.....	46
3.4.7 Timer functions monitoring .....	48
3.4.8 PID-controller monitoring .....	48
3.4.9 External PID-controller monitoring.....	49
3.4.10 Multi-pump monitoring.....	49
3.4.11 Maintenance counters.....	49
3.4.12 Fieldbus data monitoring .....	50
3.4.13 Programming of digital and analogue inputs.....	51
3.4.14 Group 3.1: Motor settings .....	58
3.4.15 Group 3.2: Start/Stop setup .....	64
3.4.16 Group 3.3: References.....	66
3.4.17 Group 3.4: Ramps & Brakes Setup .....	75

3.4.18 Group 3.5: I/O Configuration .....	77
3.4.19 Group 3.6: Fieldbus Data Mapping .....	88
3.4.20 Group 3.7: Prohibit Frequencies .....	89
3.4.21 Group 3.8: Supervisions .....	90
3.4.22 Group 3.9: Protections .....	91
3.4.23 Group 3.10: Automatic reset .....	98
3.4.24 Group 3.11: Application settings .....	99
3.4.25 Group 3.12: Timer functions .....	100
3.4.26 Group 3.13: PID-controller 1 .....	106
3.4.27 Group 3.14: External PID-controller .....	117
3.4.28 Group 3.15: Multi-pump .....	121
3.4.29 Group 3.16: Maintenance counters .....	123
3.4.30 Group 3.17: Fire mode.....	124
3.4.31 Group 3.18: Motor preheat parameters.....	126
3.4.32 Group 3.20: Mechanical brake .....	127
3.4.33 Group 3.21: Pump control .....	128
3.5 Additional parameter information .....	131
3.6 Fault tracing .....	186
3.6.1 Fault appears .....	186
3.6.2 Fault history .....	187
3.6.3 Fault codes .....	188

# 1. VACON 100 - STARTUP

**NOTE!** This manual includes a large amount of parameter tables. Below you can find the column names and their explanations:

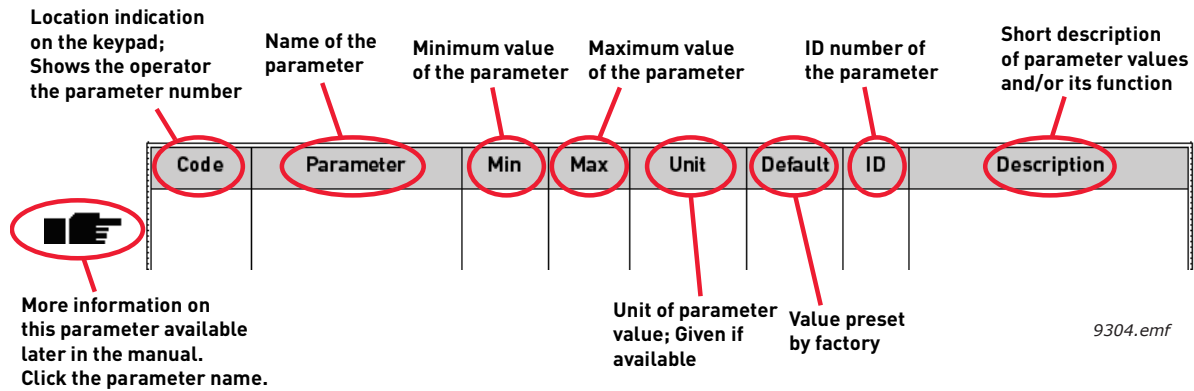

## 1.1 STARTUP WIZARD

In the *Startup Wizard*, you will be prompted for essential information needed by the drive so that it can start controlling your process. In the Wizard, you will need the Left/Right and Up/Down arrow buttons, the OK button and the Back/Reset button. See Chapter 2.1 for button descriptions.

Note! Pressing the Back/Reset button, you can return to the previous question in the Wizard. If pressed at the first question, the Startup Wizard will be cancelled.

Once you have connected power to your Vacon 100 AC drive, follow these instructions to easily set up your drive.

**NOTE:** You can have your AC drive equipped with a keypad with either a graphical or a text keypad.

<b>1</b>	Language selection (P6.1)	Depends on language package
----------	---------------------------	-----------------------------

<b>2</b>	Daylight saving* (P5.5.5)	Russia US EU OFF
<b>3</b>	Time* (P5.5.2)	hh:mm:ss
<b>4</b>	Year* (P5.5.4)	yyyy
<b>5</b>	Date* (P5.5.3)	dd.mm.

\* These questions appear if battery is installed

<b>6</b>	Run Startup Wizard (B1.1)?	Yes No
----------	----------------------------	-----------

Push the OK button unless you want to set all parameter values manually.

<b>7</b>	Set value for <i>P3.1.1.1 Motor nominal voltage</i> (according to nameplate)	<i>Range: Varies</i>
<b>8</b>	Set value for <i>P3.1.1.2 Motor nominal frequency</i> (according to nameplate)	8.00...320.00 Hz
<b>9</b>	Set value for <i>P3.1.1.3 Motor nominal speed</i> (according to nameplate)	<i>Range: 24...19,200 rpm</i>
<b>10</b>	Set value for <i>P3.1.1.4 Motor nominal current</i> (according to nameplate)	<i>Range: Varies</i>
<b>11</b>	Set value for <i>P3.1.1.5 Motor Cos Phi</i> (according to nameplate)	<i>Range: 0.30...1.00</i>
<b>12</b>	Set value for <i>P3.3.1.1 Minimum frequency reference</i>	<i>Range: 0.00...50.00 Hz</i>
<b>13</b>	Set value for <i>P3.3.1.2 Maximum frequency reference</i>	<i>Range: 0.00...320.00 Hz</i>
<b>14</b>	Set value for <i>P3.4.1.2 Acceleration time 1</i>	<i>Range: 0.1...300.0 s</i>
<b>15</b>	Set value for <i>P3.4.1.3 Deceleration time 1</i>	<i>Range: 0.1...300.0 s</i>

Now the Startup Wizard is done.

The Startup Wizard can be re-initiated by activating the parameter *Restore factory defaults* (par. P6.5.1) in the Parameter backup submenu (M6.5) OR choosing *Activate* for parameter B1.1.2 in the Quick setup / Wizards menu.

## 1.2 I/O CONFIGURATION WIZARD

I/O configuration wizard is activated in the Quick Setup / Wizards menu (B1.1.1).

This wizard is intended for the easy configuration of the drives standard I/O by selecting one of the preset I/O configurations.

**Note!** If you already have done some I/O configurations, please check them after running the wizard!

Following preset I/O configurations can be selected:

1 = Standard I/O

2 = Local-Remote I/O

3 = PID Control I/O

See the detailed configurations from the next pages.

1.2.1 STANDARD I/O CONFIGURATION

Standard I/O board																		
Terminal	Signal	Description																
1	+10 Vref	Reference output																
2	AI1+	Analogue input, voltage or current	Frequency reference															
3	AI1-	Analogue input common, (current)																
4	AI2+	Analogue input, voltage or current	Frequency reference															
5	AI2-	Analogue input common, (current)																
6	24Vout	24V auxiliary voltage																
7	GND	I/O ground																
8	DI1	Digital input 1	Start forward															
9	DI2	Digital input 2	Start reverse															
10	DI3	Digital input 3	External fault															
11	CM	Common for DI1-DI6	*)															
12	24Vout	24V auxiliary voltage																
13	GND	I/O ground																
14	DI4	Digital input 4	<table border="1"> <tr> <th>DI4</th> <th>DI5</th> <th>Freq. ref.</th> </tr> <tr> <td>Open</td> <td>Open</td> <td>Analog input 1</td> </tr> <tr> <td>Closed</td> <td>Open</td> <td>Preset Freq. 1</td> </tr> <tr> <td>Open</td> <td>Closed</td> <td>Preset Freq. 2</td> </tr> <tr> <td>Closed</td> <td>Closed</td> <td>Preset Freq. 3</td> </tr> </table>	DI4	DI5	Freq. ref.	Open	Open	Analog input 1	Closed	Open	Preset Freq. 1	Open	Closed	Preset Freq. 2	Closed	Closed	Preset Freq. 3
DI4	DI5	Freq. ref.																
Open	Open	Analog input 1																
Closed	Open	Preset Freq. 1																
Open	Closed	Preset Freq. 2																
Closed	Closed	Preset Freq. 3																
15	DI5	Digital input 5																
16	DI6	Digital input 6																
17	CM	Common for DI1-DI6	*)															
18	AO1+	Analogue signal (+output)																
19	AO1-/GND	Analogue output common	Output frequency															
30	+24Vin	24V auxiliary input voltage																
A	RS485	Serial bus, negative	Modbus RTU															
B	RS485	Serial bus, positive																
21	RO1/1 NC	Relay output 1	RUN															
22	RO1/2 CM																	
23	RO1/3 NO																	
24	RO2/1 NC	Relay output 2	FAULT															
25	RO2/2 CM																	
26	RO2/3 NO																	
32	RO3/2 CM	Relay output 3	READY															
33	RO3/3 NO																	

9301.emf

\*) Digital inputs can be isolated from the ground with a DIP switch, see figure below

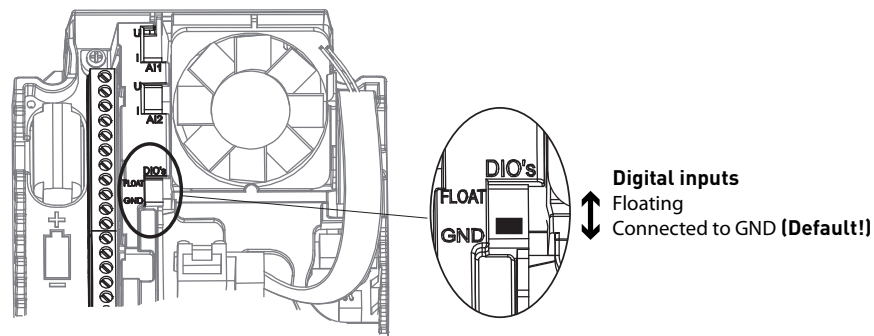

9109.emf



1.2.2 LOCAL-REMOTE I/O CONFIGURATION

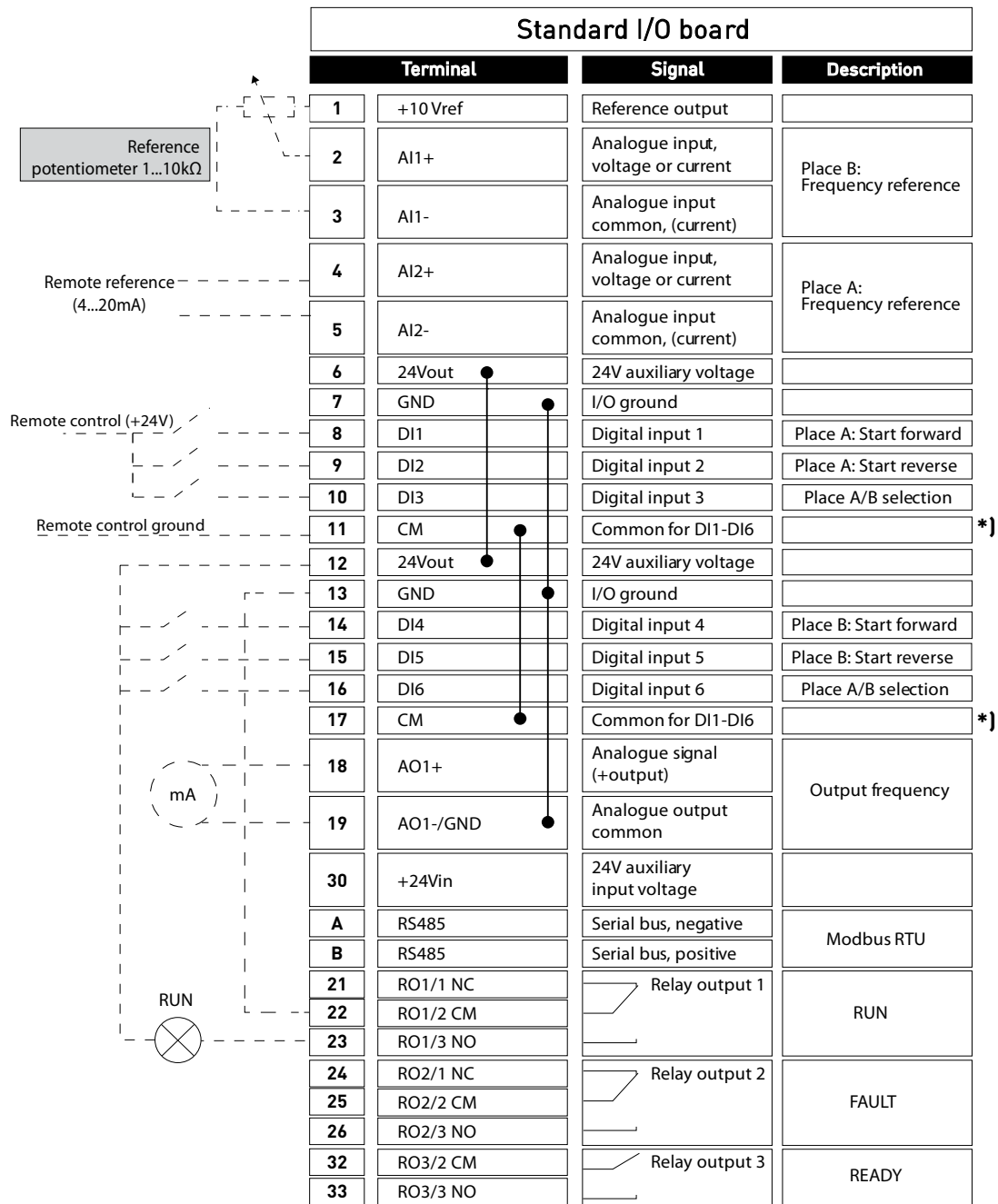

9302.emf

\*) Digital inputs can be isolated from the ground with a DIP switch, see figure below

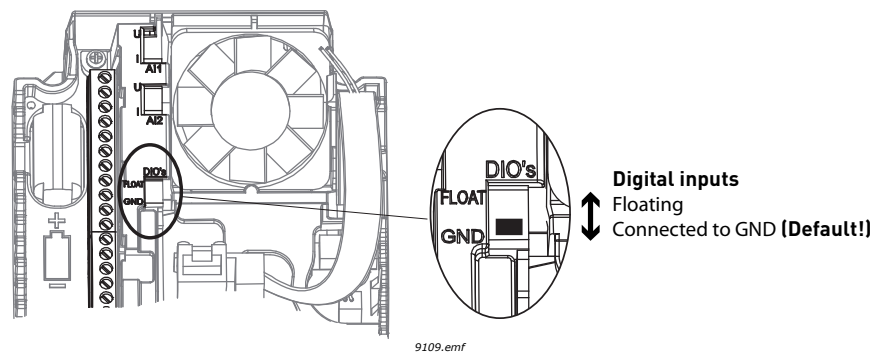

9109.emf

1.2.3 PID CONTROL I/O CONFIGURATION

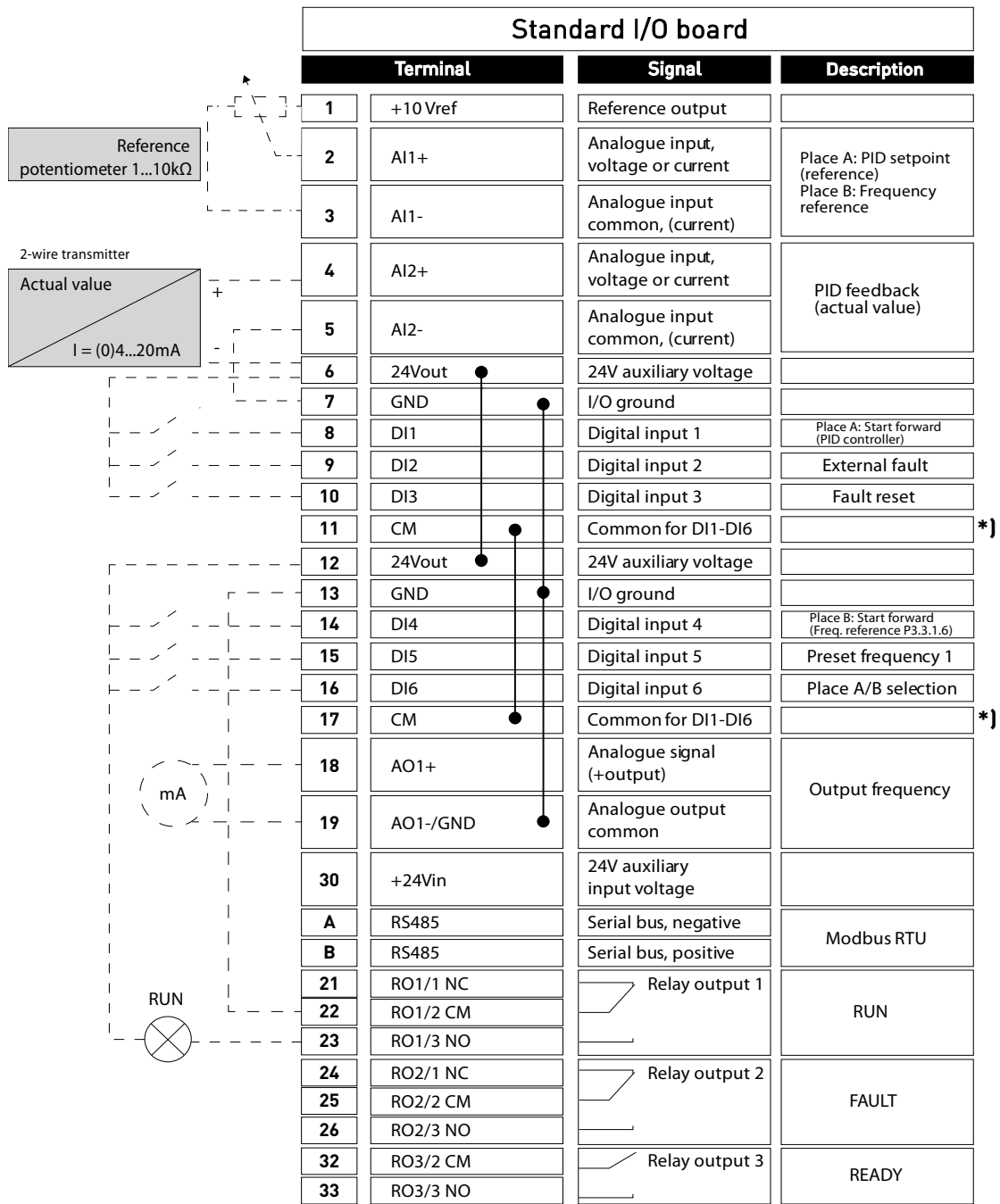

9303.emf

\*) Digital inputs can be isolated from the ground with a DIP switch, see figure below

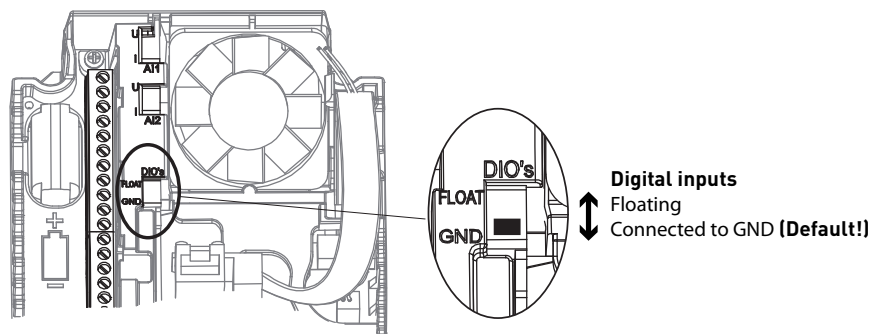

9109.emf

### 1.3 PID MINI-WIZARD

The *PID mini wizard* is activated in the *Quick Setup/Wizards* menu (B1.1.3). This wizard presupposes that you are going to use the PID controller in the "one feedback / one setpoint" mode. The control place will be I/O A and the default process unit '%'.

The *PID mini wizard* asks for the following values to be set:

<b>1</b>	Process unit selection (P3.13.1.4)	Several selections.
----------	------------------------------------	---------------------

If any other process unit than '%' is selected the following questions appear: If not the Wizard will directly jump to step 5.

<b>2</b>	Process unit min (P3.13.1.5)	Depends on selection at step 1.
<b>3</b>	Process unit max (P3.13.1.6)	Depends on selection at step 1.
<b>4</b>	Process unit decimals (P3.13.1.7)	0...4

<b>5</b>	Feedback 1 source selection (P3.13.3.3)	See page 107 for selections.
----------	-----------------------------------------	------------------------------

If one of the analogue input signals is selected the question 6 appears. Otherwise you will be taken to question 7.

<b>6</b>	Analogue input signal range	0 = 0...10V / 0...20mA 1 = 2...10V / 4...20mA See page 80.
----------	-----------------------------	------------------------------------------------------------------

<b>7</b>	Error inversion (P3.13.1.8)	0 = Normal 1 = Inverted
<b>8</b>	Setpoint source selection (P3.13.2.6)	See page 105 for selections.

If one of the analogue input signals is selected the question 9 appears. Otherwise you will be taken to question 11.

If either of the options Keypad Setpoint 1 or 2 is chosen the question 10 will appear.

<b>9</b>	Analogue input signal range	0 = 0...10V / 0...20mA 1 = 2...10V / 4...20mA See page 80.
<b>10</b>	Keypad setpoint (P3.13.2.1/ P3.13.2.2)	Depends on selection at step 1.

<b>11</b>	Sleep function?	No Yes
-----------	-----------------	-----------

If option 'Yes' is selected you will be prompted for three more values:

<b>12</b>	Sleep frequency limit 1 (P3.13.5.1)	0.00...320.00 Hz
<b>13</b>	Sleep delay 1 (P3.13.5.2)	0...3000 s

<b>14</b>	Wake-up level 1 (P3.13.5.6)	Range depends on selected process unit.
-----------	-----------------------------	-----------------------------------------

#### 1.4 MULTI-PUMP MINI-WIZARD

The Multi-Pump mini-wizard asks the most important questions for setting up a Multi-Pump system. The PID mini-wizard always precedes the Multi-Pump mini-wizard. The keypad will guide you through the questions as in chapter then to be followed by the set of questions below:

<b>15</b>	Number of motors (P3.15.1)	1...6
<b>16</b>	Interlock function (P3.15.2)	0 = Not used 1 = Enabled
<b>17</b>	Autochange (P3.15.4)	0 = Disabled 1 = Enabled

If Autochange function is enabled the following three questions will appear. If Autochange will not be used the Wizard jumps directly to question 21.

<b>18</b>	Include FC (P3.15.3)	0 = Disabled 1 = Enabled
<b>19</b>	Autochange interval (P3.15.5)	0.0...3000.0 h
<b>20</b>	Autochange: Frequency limit (P3.15.6)	0.00...50.00 Hz

<b>21</b>	Bandwidth (P3.15.8)	0...100%
<b>22</b>	Bandwidth delay (P3.15.9)	0...3600 s

After this, the keypad will show the digital input and relay output configuration done by the application (graphical keypad only). Write these values down for future reference.

The Multi-Pump Wizard can be re-initiated by choosing *Activate* for parameter B1.1.4 in the Quick setup / Wizards menu.

### 1.5 FIRE MODE WIZARD

Fire Mode Wizard is intended for easy commissioning of the Fire Mode function. The Fire Mode Wizard can be initiated by choosing *Activate* for parameter B1.4 in the Quick setup menu.

**NOTE!** Read some important information about the password and warranty issues in chapter 3.4.30 before you proceed.

<b>1</b>	Fire Mode frequency source (P3.17.2)	Several selections.
----------	--------------------------------------	---------------------

If any other source than '*Fire mode frequency*' is selected the wizard will jump directly to question 3.

<b>2</b>	Fire Mode frequency (P3.17.3)	8.00 Hz...MaxFreqRef (P3.3.1.2)
<b>3</b>	Signal activation?	Should the signal activate on opening or closing contact? 0 = Open contact 1 = Closed contact
<b>4</b>	Fire Mode activation on OPEN (P3.17.4)/ Fire Mode activation on CLOSE (P3.17.5)	Choose the digital input to activate Fire mode. See also chapter 3.4.13.
<b>5</b>	Fire Mode reverse (P3.17.6)	Choose the digital input to activate the reverse direction in Fire mode. DigIn Slot0.1 = Always direction FORWARD DigIn Slot0.2 = Always direction REVERSE
<b>6</b>	Fire Mode password (P3.17.1)	Choose password to enable the Fire Mode function. 1234 = Enable test mode 1002 = Enable Fire Mode

## 2. KEYPAD OF THE DRIVE

The control keypad is the interface between the Vacon 100 AC drive and the user. With the control keypad it is possible to control the speed of a motor, to supervise the state of the equipment and to set the AC drive's parameters.

There are two keypad types you can choose for your user interface: *Keypad with graphical display* and *Text keypad*.

### 2.1 BUTTONS

The button section of the keypad is identical for both keypad types.

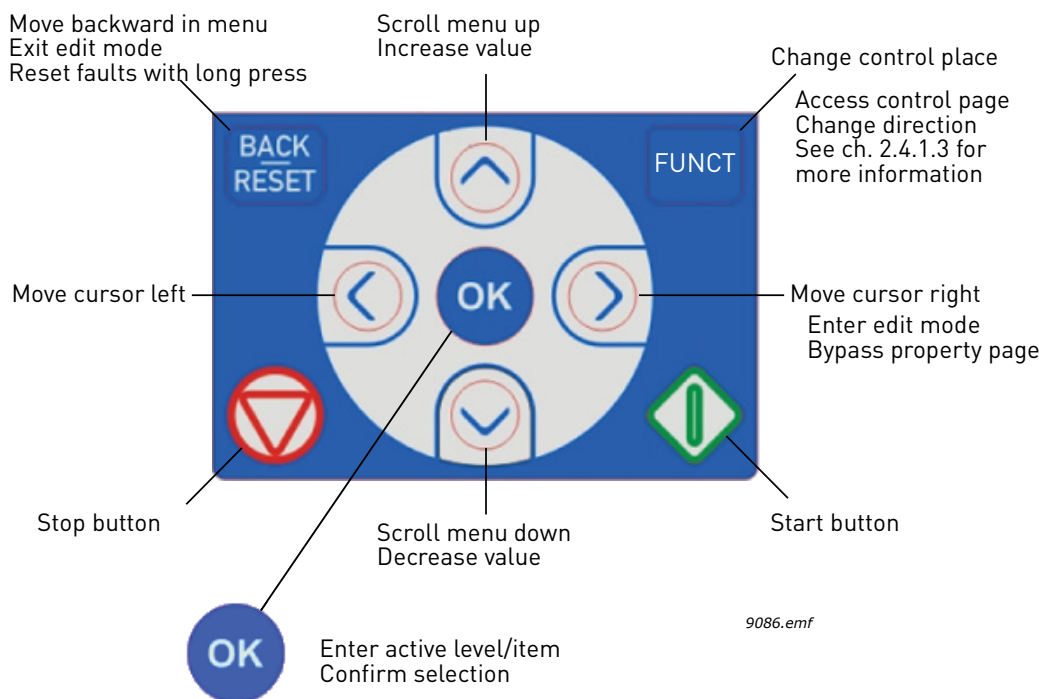

Figure 1. Keypad buttons

### 2.2 DISPLAY

The keypad display indicates the status of the motor and the drive and any irregularities in motor or drive functions. On the display, the user sees information about the drive and his present location in the menu structure and the item displayed.

### 2.3 NAVIGATION ON KEYPAD

The data on the control keypad are arranged in menus and submenus. Use the Up and Down arrows to move between the menus. Enter the group/item by pressing the OK button and return to the former level by pressing the Back/Reset button.

**The Location field indicates your current location. The Status field gives information about the present status of the drive.** See Figure 3.

The basic menu structure is depicted on page 12.

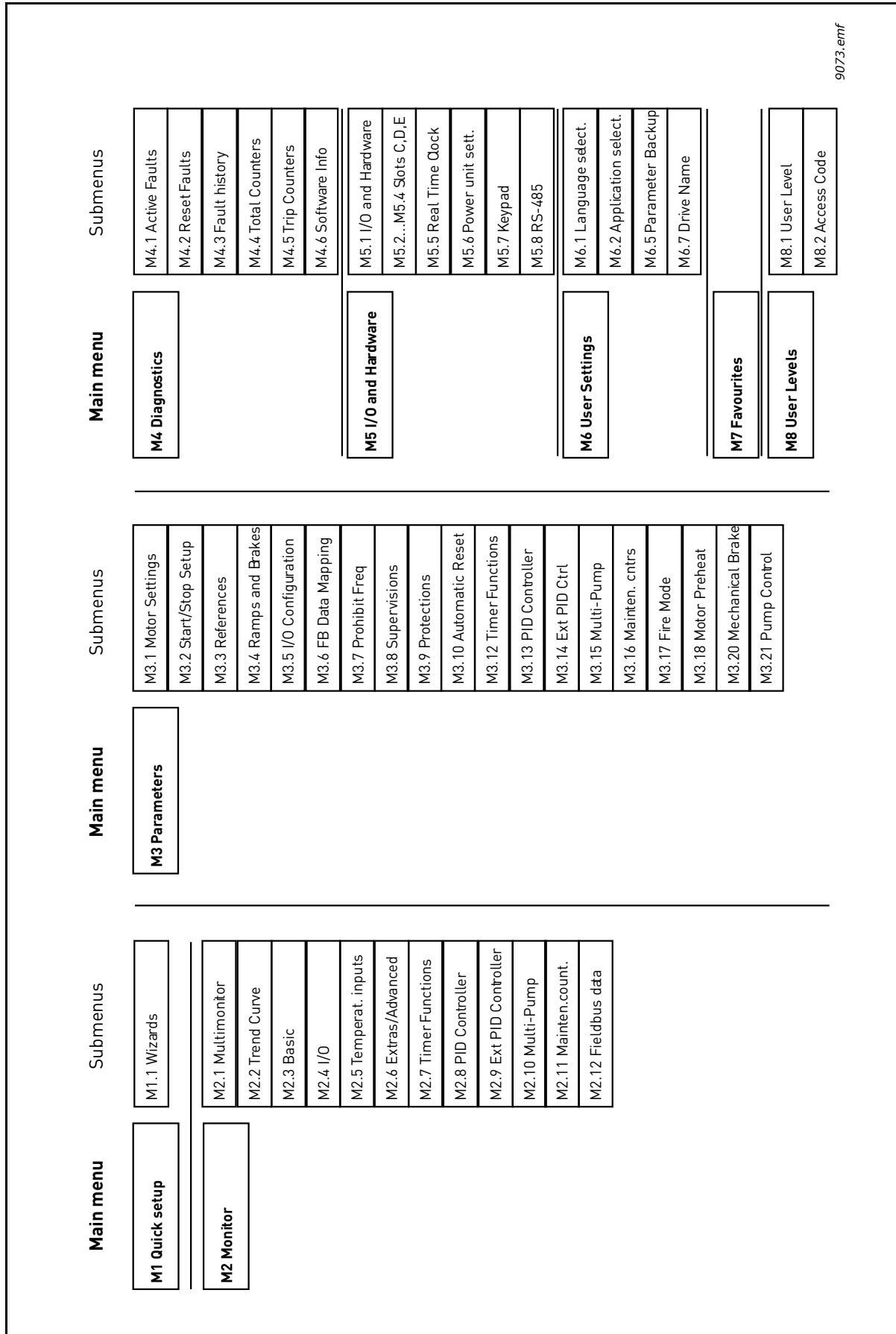

Figure 2. Keypad navigation chart

## 2.4 VACON GRAPHICAL KEYPAD

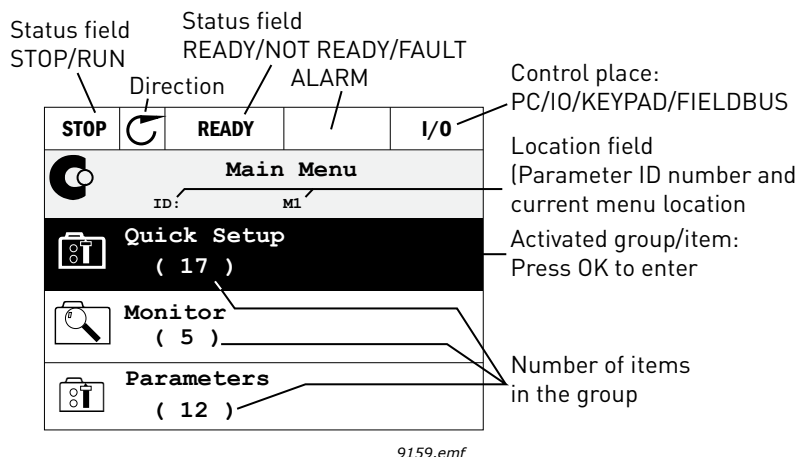

Figure 3. Main menu

### 2.4.1 USING THE GRAPHICAL KEYPAD

#### 2.4.1.1 Editing values

The selectable values can be accessed and edited in two different ways on the graphical keypad.

#### Parameters with one valid value

Typically, one parameter is set one value. The value is selected either from a list of values (see example below) or the parameter is given a numerical value from a defined range (e.g. 0.00...50.00 Hz).

Change value of a parameter following the procedure below:

1. Locate the parameter.
2. Enter the *Edit* mode.
3. Set new value with the arrow buttons up/down. You can also move from digit to digit with the arrow buttons left/right if the value is numerical and then change the value with the arrow buttons up/down.
4. Confirm change with OK button or ignore change by returning to previous level with Back/Reset button.



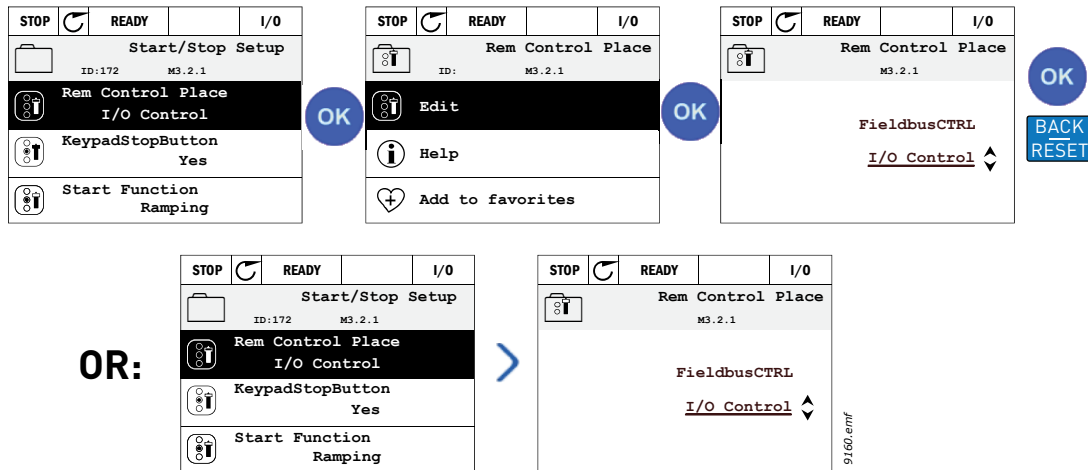

Figure 4. Typical editing of values on graphical keypad (text value)



Figure 5. Typical editing of values on graphical keypad (numerical value)

### Parameters with checkbox selection

Some parameters allow selecting several values. Make a checkbox selection at each value you wish to activate as instructed below.

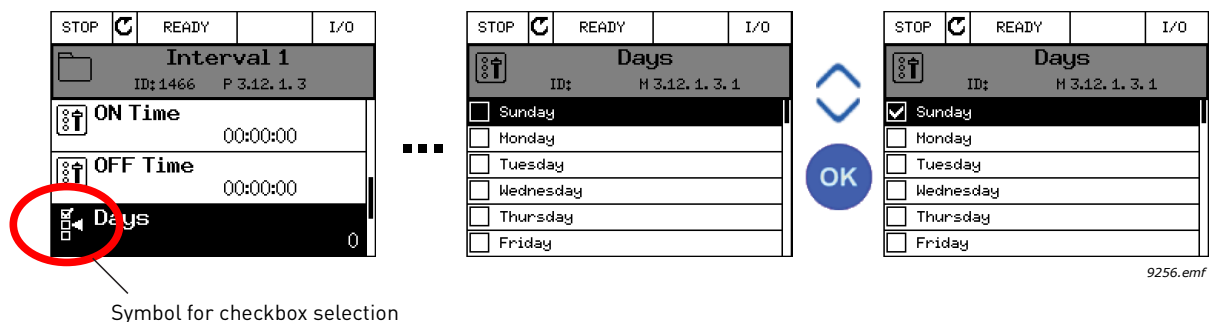

Symbol for checkbox selection

Figure 6. Applying the checkbox value selection on graphical keypad

### 2.4.1.2    Resetting fault

Instructions for how to reset a fault can be found in chapter 3.6.1 on page 184.

### 2.4.1.3    Function button

The FUNCT button is used for four functions:

1. to quickly access the Control page,
2. to easily change between the Local (Keypad) and Remote control places,
3. to change the rotation direction and
4. to quickly edit a parameter value.

## **Control places**

The *control place* is the source of control where the drive can be started and stopped. Every control place has its own parameter for selecting the frequency reference source. The *Local control place* is always the keypad. The *Remote control place* is determined by parameter P3.2.1 (I/O or Fieldbus). The selected control place can be seen on the status bar of the keypad.

## **Remote control place**

I/O A, I/O B and Fieldbus can be used as remote control places. I/O A and Fieldbus have the lowest priority and can be chosen with parameter P3.2.1 (*Rem Control Place*). I/O B, again, can bypass the remote control place selected with parameter P3.2.1 using a digital input. The digital input is selected with parameter P3.5.1.7 (*I/O B Ctrl Force*).

## **Local control**

Keypad is always used as control place while in local control. Local control has higher priority than remote control. Therefore, if, for example, bypassed by parameter P3.5.1.7 through digital input while in *Remote*, the control place will still switch to Keypad if *Local* is selected. Switching between Local and Remote Control can be done by pressing the FUNCT-button on the keypad or by using the "Local/Remote" (ID211) parameter.

## **Changing control places**

Change of control place from *Remote* to *Local* (keypad).

1. Anywhere in the menu structure, push the *FUNCT* button.
2. Push the *Arrow up* or the *Arrow down* button to select *Local/Remote* and confirm with the *OK* button.
3. On the next display, select *Local* or *Remote* and again confirm with the *OK* button.
4. The display will return to the same location as it was when the *FUNCT* button was pushed. However, if the Remote control place was changed to Local (Keypad) you will be prompted for keypad reference.

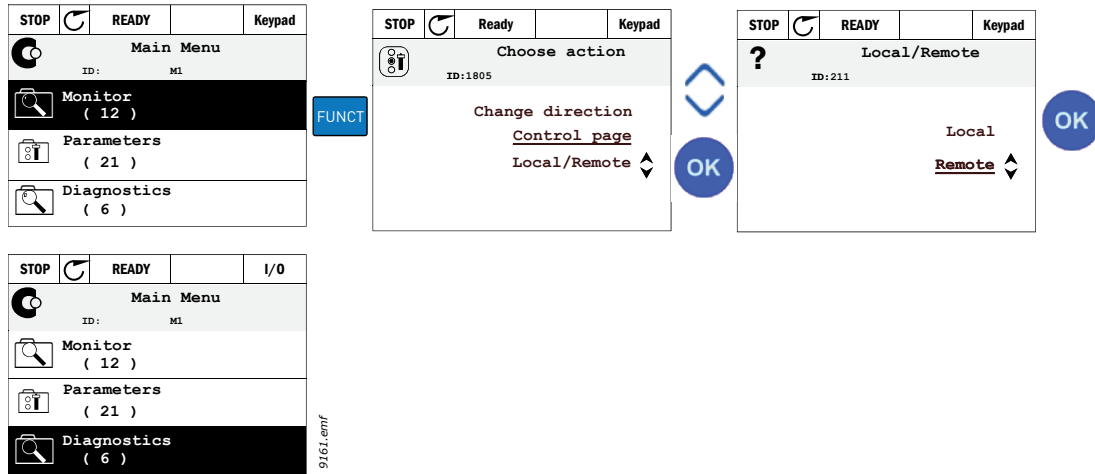

Figure 7. Changing control places

### Accessing the control page

The *Control page* is meant for easy operation and monitoring of the most essential values.

1. Anywhere in the menu structure, push the *FUNCT* button.
2. Push the *Arrow up* or the *Arrow down* button to select *Control page* and confirm with the *OK* button.
3. The control page appears

If keypad control place and keypad reference are selected to be used you can set the *Keypad reference* after having pressed the *OK* button. If other control places or reference values are used the display will show Frequency reference which is not editable. The other values on the page are Multimonitoring values. You can choose which values appear here for monitoring (for this procedure, see page 26).

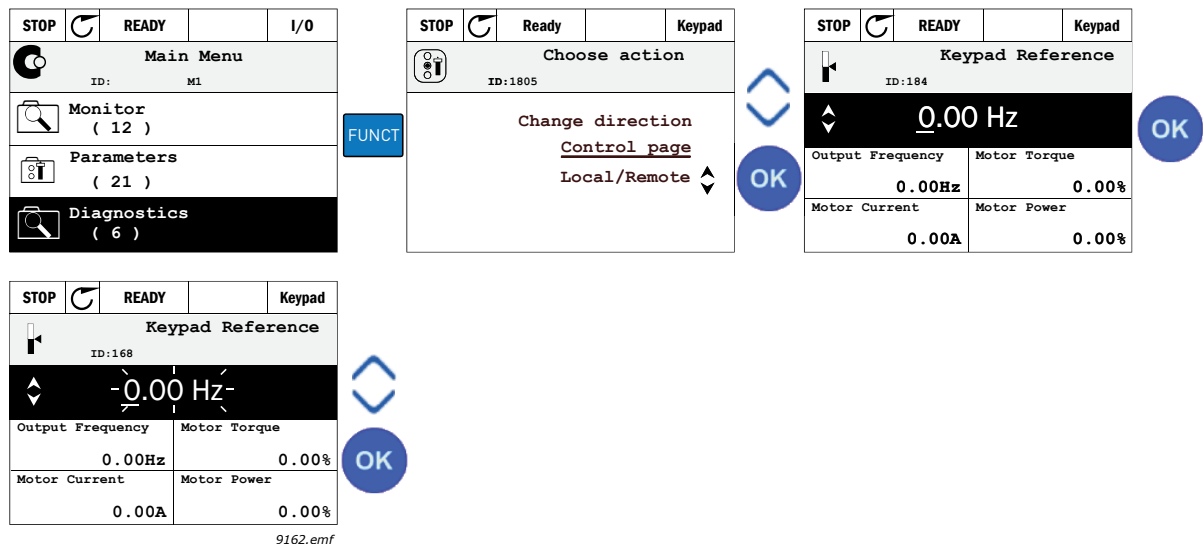
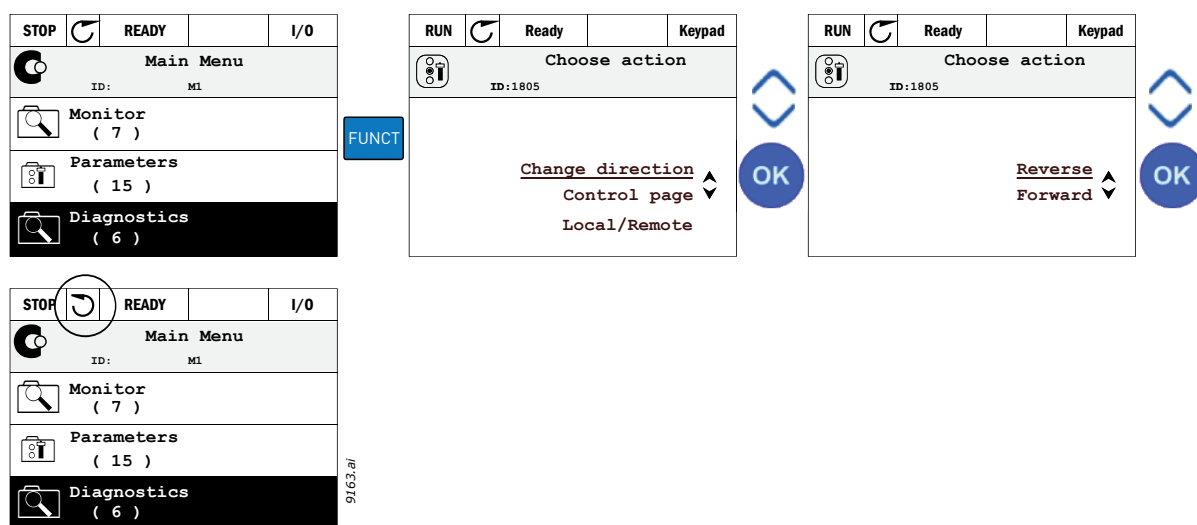

Figure 8. Accessing Control page

### Changing direction

Rotation direction of the motor can quickly be changed by applying the FUNCT button. **NOTE!** *Changing direction* command is not visible in the menu unless the selected control place is *Local*.

1. Anywhere in the menu structure, push the Funct button.
2. Push the Arrow up or the Arrow down button to select Change direction and confirm with the OK button.
3. Then choose the direction you wish to run the motor to. The actual rotation direction is blinking. Confirm with the OK button.
4. The rotation direction changes immediately and the arrow indication in the status field changes.



### Quick edit

Through the *Quick edit* functionality you can quickly access the desired parameter by entering the parameter's ID number.

1. Anywhere in the menu structure, push the FUNCT button.
2. Push the Arrow up or the Arrow down buttons to select Quick Edit and confirm with the OK button.
3. Then enter the ID number of parameter or monitoring value you wish to access. Press OK button to confirm.
4. Requested Parameter/Monitoring value appears on the display (in editing/monitoring mode.)

### 2.4.1.4 Copying parameters

**NOTE:** This feature is available in graphical keypad only.

The parameter copy function can be used to copy parameters from one drive to another.

The parameters are first saved to the keypad, then the keypad is detached and connected to another drive. Finally the parameters are downloaded to the new drive restoring them from the keypad.

Before any parameters can successfully be copied from the keypad to the drive, the drive **has to be stopped** before the parameters are uploaded.

- First go into *User settings* menu and locate the *Parameter backup* submenu. In the *Parameter backup* submenu, there are three possible functions to be selected:
- *Restore factory defaults* will re-establish the parameter settings originally made at the factory.
- By selecting *Save to keypad* you can copy all parameters to the keypad.
- *Restore from keypad* will copy all parameters from keypad to a drive.

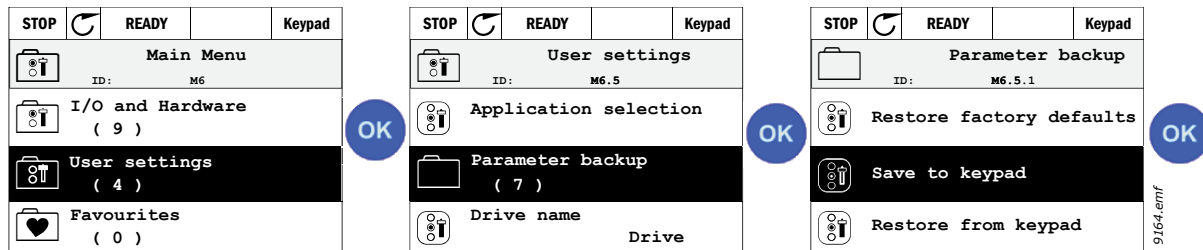

Figure 9. Parameter copy

**NOTE:** If the keypad is changed between drives of different sizes, the copied values of these parameters will not be used:

- Motor nominal current (P3.1.1.4)
- Motor nominal voltage (P3.1.1.1)
- Motor nominal speed (P3.1.1.3)
- Motor nominal power (P3.1.1.6)
- Motor nominal frequency (P3.1.1.2)
- Motor cos phii (P3.1.1.5)
- Switching frequency (P3.1.2.3)
- Motor current limit (P3.1.3.1)
- Stall current limit (P3.9.3.2)
- Maximum frequency (P3.3.1.2)
- Field weakening point frequency (P3.1.4.2)
- U/f midpoint frequency (P3.1.4.4)
- Zero frequency voltage (P3.1.4.6)
- Start magnetizing current (P3.4.3.1)
- DC brake current (P3.4.4.1)
- Flux braking current (P3.4.5.2)
- Motor thermal time constant (P3.9.2.4)

### 2.4.1.5 Comparing parameters

With this function, the user can compare the active parameter set with one of these four sets:

- Set 1 (B6.5.4: Save to Set 1, see ch. 2.6.6.1 )
- Set 2 (B6.5.6: Save to Set 2, see ch. 2.6.6.1)
- Defaults (Factory defaults, see ch. 2.6.6.1)
- Keypad set (B6.5.2: Save to Keypad, see ch. 2.6.6.1)

See figure below.

**NOTE!** If the parameter set to be compared with has not been saved, the display shows: “Comparing failed”

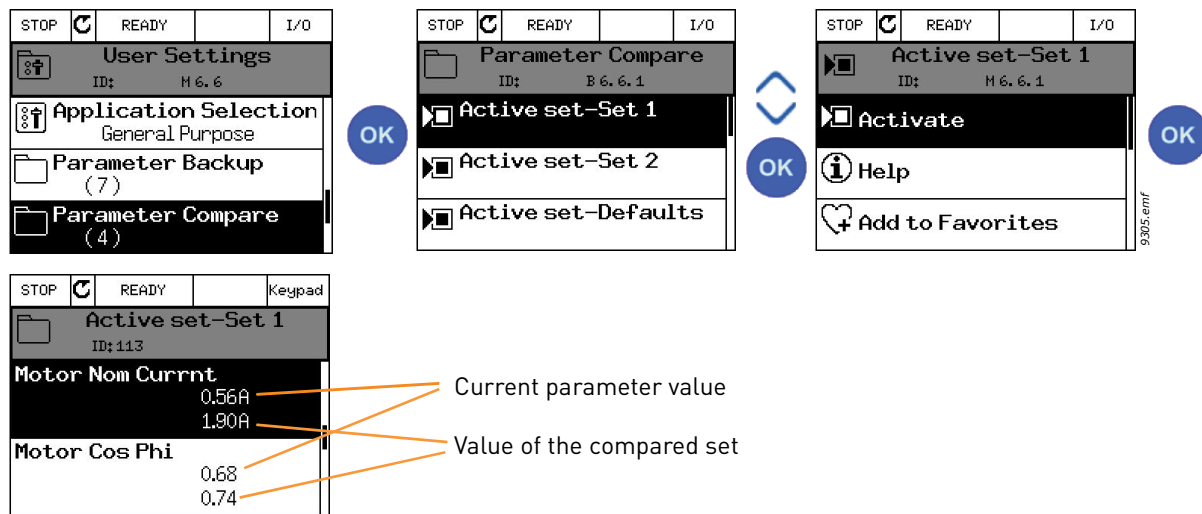

Figure 10. Parameter compare

2.4.1.6 Help texts

The graphical keypad features instant help and information displays for various items. All parameters offer an instant help display. Select Help and press the OK button. Text information is also available for faults, alarms and the startup wizard.

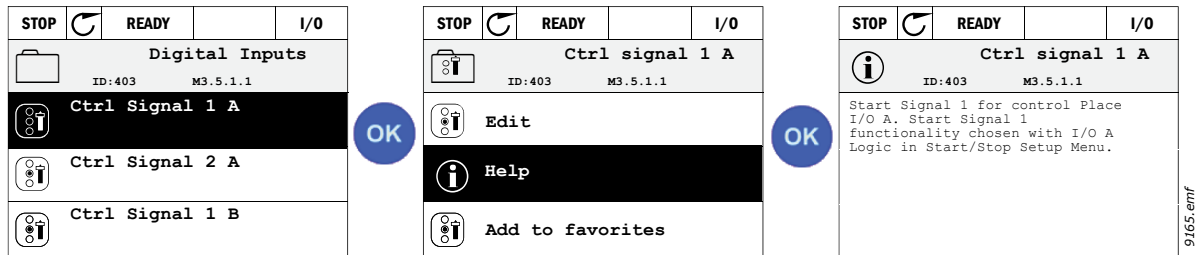

Figure 11. Help text example

2.4.1.7 Adding item to favorites

You might need to refer to certain parameter values or other items often. Instead of locating them one by one in the menu structure, you may want to add them to a folder called *Favorites* where they can easily be reached.

To remove an item from the Favorites, see chapter 2.6.7.

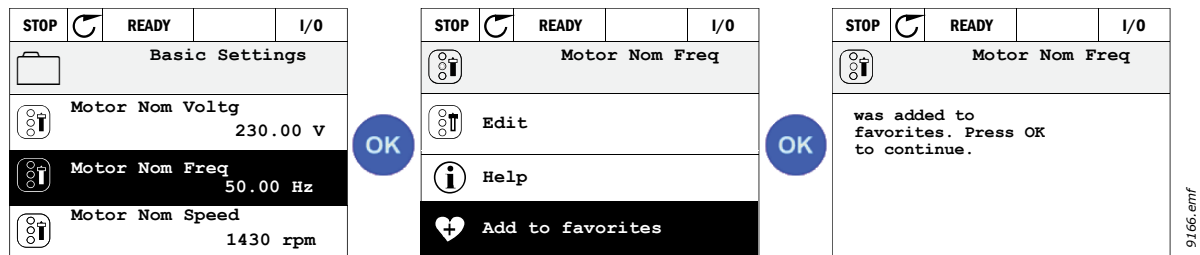

Figure 12. Adding item to Favorites

## 2.5 VACON TEXT KEYPAD

You can also choose a so-called *Text keypad* for your user interface. It has mainly the same functionalities as the graphical keypad although some of these are somewhat limited.

### 2.5.1 KEYPAD DISPLAY

The keypad display indicates the status of the motor and the drive and any irregularities in motor or drive functions. On the display, the user sees information about the drive and his present location in the menu structure and the item displayed. If the text on the text line is too long to fit in the display, the text will scroll from left to right to reveal the whole text string.

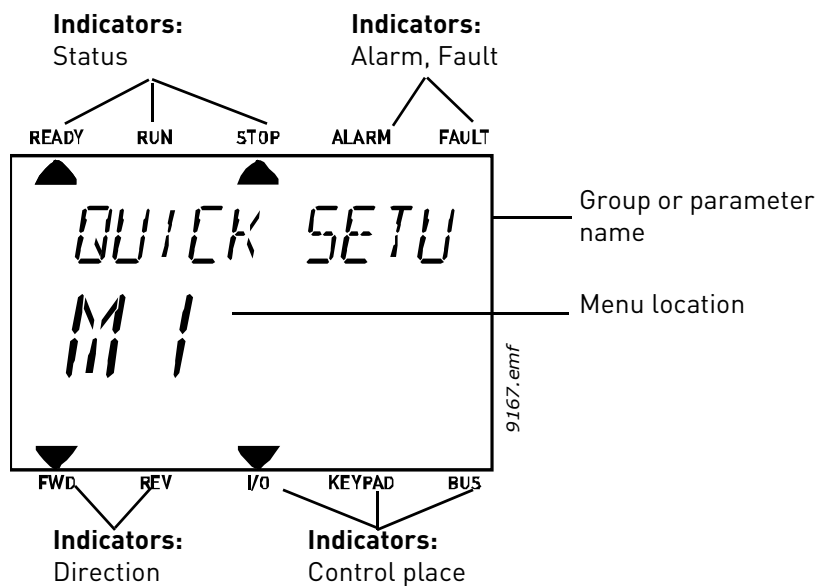



## 2.5.2 USING THE TEXT KEYPAD

### 2.5.2.1 Editing values

Change value of a parameter following the procedure below:

1. Locate the parameter.
2. Enter the Edit mode by pressing OK.
3. Set new value with the arrow buttons up/down. You can also move from digit to digit with the arrow buttons left/right if the value is numerical and change then the value with the arrow buttons up/down.
4. Confirm change with OK button or ignore change by returning to previous level with Back/Reset button.

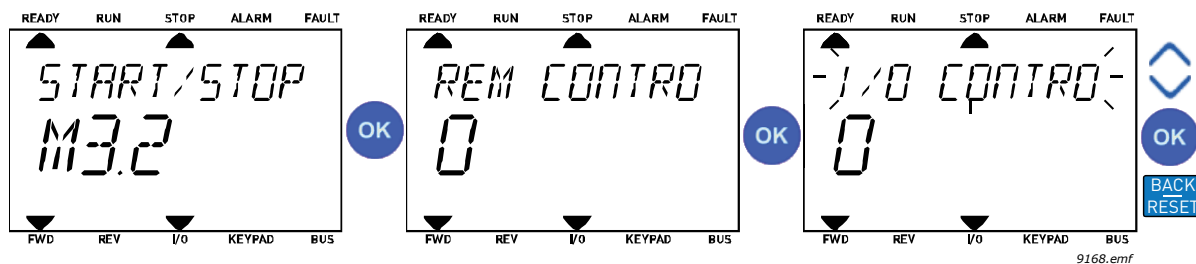

Figure 13. Editing values

### 2.5.2.2 Resetting fault

Instructions for how to reset a fault can be found in chapter 3.6.1 on page 184.

### 2.5.2.3 Function button

The FUNCT button is used for four functions:

#### Control places

The *control place* is the source of control where the drive can be started and stopped. Every control place has its own parameter for selecting the frequency reference source. The *Local control place* is always the keypad. The *Remote control place* is determined by parameter P3.2.1 (I/O or Fieldbus). The selected control place can be seen on the status bar of the keypad.

#### Remote control place

I/O A, I/O B and Fieldbus can be used as remote control places. I/O A and Fieldbus have the lowest priority and can be chosen with parameter P3.2.1 (*Rem Control Place*). I/O B, again, can bypass the remote control place selected with parameter P3.2.1 using a digital input. The digital input is selected with parameter P3.5.1.7 (*I/O B Ctrl Force*).

#### Local control

Keypad is always used as control place while in local control. Local control has higher priority than remote control. Therefore, if, for example, bypassed by parameter P3.5.1.7 through digital input while in *Remote*, the control place will still switch to Keypad if *Local* is selected. Switching between Local and Remote Control can be done by pressing the FUNCT-button on the keypad or by using the "Local/Remote" (ID211) parameter.

### Changing control places

Change of control place from *Remote* to *Local* (keypad).

1. Anywhere in the menu structure, push the *FUNCT* button.
2. Using the arrow buttons, select *Local/Remote* and confirm with the *OK* button.
3. On the next display, select *Local* or *Remote* and again confirm with the *OK* button.
4. The display will return to the same location as it was when the *FUNCT* button was pushed. However, if the *Remote* control place was changed to *Local* (Keypad) you will be prompted for keypad reference.

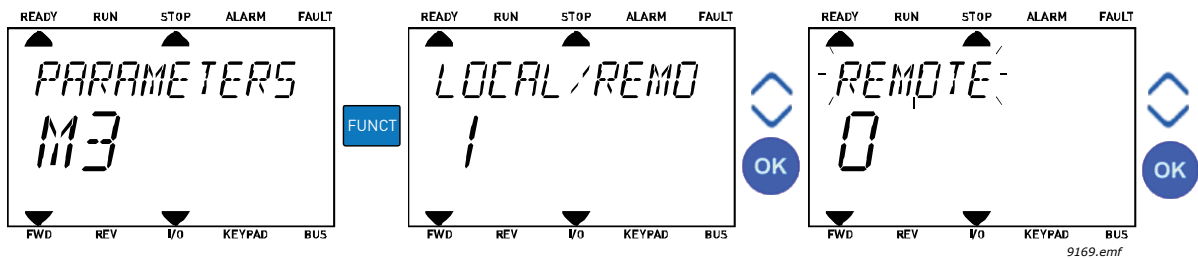

Figure 14. Changing control places

### Accessing the control page

The *Control page* is meant for easy operation and monitoring of the most essential values.

1. Anywhere in the menu structure, push the *FUNCT* button.
2. Push the *Arrow up* or the *Arrow down* button to select *Control page* and confirm with the *OK* button.
3. The control page appears  
 If keypad control place and keypad reference are selected to be used you can set the *Keypad reference* after having pressed the *OK* button. If other control places or reference values are used the display will show Frequency reference which is not editable.

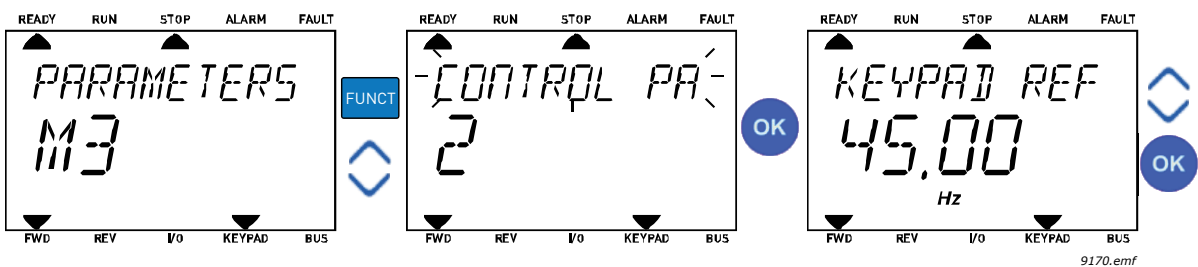

Figure 15. Accessing Control page

## Changing direction

Rotation direction of the motor can quickly be changed by applying the FUNCT button. **NOTE!** *Changing direction* command is not visible in the menu unless the selected control place is *Local*.

1. Anywhere in the menu structure, push the Funct button.
2. Push the Arrow up or the Arrow down button to select Change direction and confirm with the OK button.
3. Then choose the direction you wish to run the motor to. The actual rotation direction is blinking. Confirm with the OK button.
4. The rotation direction changes immediately and the arrow indication in the status field changes.

## Quick edit

Through the *Quick edit* functionality you can quickly access the desired parameter by entering the parameter's ID number.

1. Anywhere in the menu structure, push the FUNCT button.
2. Push the Arrow up or the Arrow down buttons to select Quick Edit and confirm with the OK button.
3. Then enter the ID number of parameter or monitoring value you wish to access. Press OK button to confirm.
4. Requested Parameter/Monitoring value appears on the display (in editing/monitoring mode.)

## 2.6 MENU STRUCTURE

Click on and select the item you wish to receive more information about (electronic manual).

*Table 1. Keypad menus*

<b>Quick setup</b>	See chapter 3.3.
<b>Monitor</b>	Multi-monitor*
	Trend curve*
	Basic
	I/O
	Extras/Advanced
	Timer functions
	PID Controller
	External PID Controller
	Multi-Pump
	Maintenance counters
	Fieldbus data
<b>Parameters</b>	See chapter 3.
<b>Diagnostics</b>	Active faults
	Reset faults
	Fault history
	Total counters
	Trip counters
	Software info
<b>I/O and hardware</b>	Basic I/O
	Slot C
	Slot D
	Slot E
	Real time clock
	Power unit settings
	Keypad
	RS-485
	Ethernet
<b>User settings</b>	Language selections
	Application selection
	Parameter backup*
	Drive name
	Parameter compare
<b>Favorites *</b>	See chapter 2.4.1.7.
<b>User levels</b>	See chapter 2.6.8.

\*. Not available in text keypad

### 2.6.1 QUICK SETUP

The Quick Setup group includes the different wizards and quick setup parameters of the Vacon 100 Application. More detailed information on the parameters of this group you will find in chapter 3.3.

### 2.6.2 MONITOR

#### Multi-monitor

**NOTE:** This menu is not available in text keypad.

On the multi-monitor page, you can collect four to nine values that you wish to monitor. The number of the monitored items can be selected with parameter 3.11.4.



Figure 16. Multi-monitoring page

Change the monitored value by activating the value cell (with arrow buttons left/right) and clicking OK. Then choose a new item on the Monitoring values list and click OK again.

#### Trend curve

The *Trend Curve* feature is a graphical presentation of two monitor values at a time.

#### Basic

The basic monitoring values are the actual values of selected parameters and signals as well as statuses and measurements.

#### I/O

Statuses and levels of various input and output signal values can be monitored here. See chapter 3.4.4.

#### Extras/Advanced

Monitoring of different advanced values, e.g. fieldbus values. See chapter 3.4.6.

#### Timer functions

Monitoring of timer functions and the Real Time Clock. See chapter 3.4.7.

#### PID Controller

Monitoring of PID controller values. See chapter 3.4.8.

**External PID Controller**

Monitoring of external PID controller values. See chapter 3.4.9.

**Multi-Pump**

Monitoring of values related to the use of several drives. See chapter 3.4.10.

**Maintenance counters**

Monitoring of values related to Maintenance counters. See chapter 3.4.11.

**Fieldbus data**

Fieldbus data shown as monitor values for debugging purposes at e.g. fieldbus commissioning. See chapter 3.4.12.

### 2.6.3 PARAMETERS

Through this submenu, you can reach the application parameter groups and parameters. More information on parameters in chapter 3.

### 2.6.4 DIAGNOSTICS

Under this menu, you can find *Active faults*, *Reset faults*, *Fault history*, *Counters* and *Software info*.

#### 2.6.4.1 Active faults

Table 2.

Menu	Function	Note
<b>Active faults</b>	When a fault/faults appear(s), the display with the name of the fault starts to blink. Press OK to return to the Diagnostics menu. The <i>Active faults</i> submenu shows the number of faults. Select the fault and push OK to see the fault-time data.	The fault remains active until it is cleared with the Reset button (push for 2 s) or with a reset signal from the I/O terminal or fieldbus or by choosing <i>Reset faults</i> (see below). The memory of active faults can store the maximum of 10 faults in the order of appearance.

#### 2.6.4.2 Reset faults

Table 3.

Menu	Function	Note
<b>Reset faults</b>	In this menu you can reset faults. For closer instructions, see chapter 3.6.1.	 <b>CAUTION!</b> Remove external Control signal before resetting the fault to prevent unintentional restart of the drive.

#### 2.6.4.3 Fault history

Table 4.

Menu	Function	Note
<b>Fault history</b>	40 latest faults are stored in the Fault history.	Entering the Fault history and clicking OK on the selected fault shows the fault time data (details).

2.6.4.4 Total counters

Table 5. Diagnostics menu, Total counters parameters

Code	Parameter	Min	Max	Unit	Default	ID	Description
V4.4.1	Energy counter			Varies		2291	Amount of energy taken from supply network. No reset. <b>NOTE FOR TEXT KEYPAD:</b> The highest energy unit shown on the standard keypad is <i>MW</i> . Should the counted energy exceed 999.9 MW, no unit is shown on the keypad.
V4.4.3	Operating time (graphical keypad)			a d hh:min		2298	Control unit operating time
V4.4.4	Operating time (text keypad)			a			Control unit operating time in total years
V4.4.5	Operating time (text keypad)			d			Control unit operating time in total days
V4.4.6	Operating time (text keypad)			hh:min:ss			Control unit operating time in hours, minutes and seconds
V4.4.7	Run time (graphical keypad)			a d hh:min		2293	Motor running time
V4.4.8	Run time (text keypad)			a			Motor running time in total years
V4.4.9	Run time (text keypad)			d			Motor running time in total days
V4.4.10	Run time (text keypad)			hh:min:ss			Motor running time in hours, minutes and seconds
V4.4.11	Power on time (graphical keypad)			a d hh:min		2294	Amount of time the power unit has been powered so far. No reset.
V4.4.12	Power on time (text keypad)			a			Power on time in total years
V4.4.13	Power on time (text keypad)			d			Power on time in total days
V4.4.14	Power on time (text keypad)			hh:min:ss			Power on time in hours, minutes and seconds
V4.4.15	Start command counter					2295	The number of times the power unit has been started.



2.6.4.5 Trip counters

Table 6. Diagnostics menu, Trip counters parameters

Code	Parameter	Min	Max	Unit	Default	ID	Description
P4.5.1	Energy trip counter			Varies		2296	Resettable energy counter. <b>NOTE:</b> The highest energy unit shown on the standard keypad is <i>MW</i> . Should the counted energy exceed 999.9 MW, no unit is shown on the keypad. <b>To reset the counter:</b> <u>Standard text keypad:</u> Apply a long (4 s) push on the OK button. <u>Graphical keypad:</u> Push OK once. <i>Reset counter</i> page will appear. Push OK once again.
P4.5.3	Operating time (graphical keypad)			a d hh:min		2299	Resettable. See P4.5.1.
P4.5.4	Operating time (text keypad)			a			Operating time in total years
P4.5.5	Operating time (text keypad)			d			Operating time in total days
P4.5.6	Operating time (text keypad)			hh:min:ss			Operating time in hours, minutes and seconds

2.6.4.6 Software info

Table 7. Diagnostics menu, Software info parameters

Code	Parameter	Min	Max	Unit	Default	ID	Description
V4.6.1	Software package (graphical keypad)						Code for software identification
V4.6.2	Software package ID (text keypad)						
V4.6.3	Software package version (text keypad)						
V4.6.4	System load	0	100	%		2300	Load on control unit CPU.
V4.6.5	Application name (graphical keypad)						Name of application.
V4.6.6	Application ID						Application code.
V4.6.7	Application version						

### 2.6.5 I/O AND HARDWARE

Various options-related settings are located in this menu. Note that the values in this menu are raw values i.e. not scaled by the application.

#### 2.6.5.1 Basic I/O

Monitor here the statuses of inputs and outputs.

Table 8. I/O and Hardware menu, Basic I/O parameters

Code	Parameter	Min	Max	Unit	Default	ID	Description
V5.1.1	Digital input 1	0	1		0		Status of digital input signal
V5.1.2	Digital input 2	0	1		0		Status of digital input signal
V5.1.3	Digital input 3	0	1		0		Status of digital input signal
V5.1.4	Digital input 4	0	1		0		Status of digital input signal
V5.1.5	Digital input 5	0	1		0		Status of digital input signal
V5.1.6	Digital input 6	0	1		0		Status of digital input signal
V5.1.7	Analogue input 1 mode	1	3		3		Shows the selected (with jumper) mode for Analogue input signal 1 = 0...20mA 3 = 0...10V
V5.1.8	Analogue input 1	0	100	%	0.00		Status of analogue input signal
V5.1.9	Analogue input 2 mode	1	3		3		Shows the selected (with jumper) mode for Analogue input signal 1 = 0...20mA 3 = 0...10V
V5.1.10	Analogue input 2	0	100	%	0.00		Status of analogue input signal
V5.1.11	Analogue output 1 mode	1	3		1		Shows the selected (with jumper) mode for Analogue output signal 1 = 0...20mA 3 = 0...10V
V5.1.12	Analogue output 1	0	100	%	0.00		Status of analogue output signal
V5.1.13	Relay output 1	0	1		0		Status of relay output signal
V5.1.14	Relay output 2	0	1		0		Status of relay output signal
V5.1.15	Relay output 3	0	1		0		Status of relay output signal

### 2.6.5.2 Option board slots

The parameters of this group depend on the option board installed. If no option board is placed in slots C, D or E, no parameters are visible. See chapter 3.4.13 for the location of the slots.

As an option board is removed, info text 39 *Device removed* will appear on the display. See Table 137.

Table 9. Option board-related parameters

Menu	Function	Note
Slot C	Settings	Option board related settings.
	Monitoring	Monitor option board-related info.
Slot D	Settings	Option board related settings.
	Monitoring	Monitor option board-related info.
Slot E	Settings	Option board related settings.
	Monitoring	Monitor option board-related info.

### 2.6.5.3 Real time clock

Table 10. I/O and Hardware menu, Real time clock parameters

Code	Parameter	Min	Max	Unit	Default	ID	Description
V5.5.1	Battery state	1	3		2	2205	Status of battery. 1 = Not installed 2 = Installed 3 = Change battery
P5.5.2	Time			hh:mm:ss		2201	Current time of day
P5.5.3	Date			dd.mm.		2202	Current date
P5.5.4	Year			yyyy		2203	Current year
P5.5.5	Daylight saving	1	4		1	2204	Daylight saving rule 1 = Off 2 = EU; Starts on last Sunday in March, ends last Sunday in October 3 = US; Start on 2nd Sunday in March, ends on 1st Sunday in November 4 = Russia (permanent)

### 2.6.5.4 Power unit settings

#### Fan

The fan operates in optimized or always-on mode. In the optimized mode, fan speed is controlled according to the drive's internal logic that receives data from temperature measurements and the fan stops in 5 minutes when the drive is in Ready state. In always-on mode, the fan runs in full speed, without stopping.

Table 11. Power unit settings, Fan

Code	Parameter	Min	Max	Unit	Default	ID	Description
P5.6.1.1	Fan control mode	0	1		1	2377	0 = Always on 1 = Optimized

#### Brake chopper

Table 12. Power unit settings, Brake chopper

Code	Parameter	Min	Max	Unit	Default	ID	Description
P5.6.2.1	Brake chopper mode	0	3		0		0 = Disabled 1 = Enabled (Run) 2 = Enabled (Run & Stop) 3 = Enabled (Run, no testing)

#### Sine filter

Sine filter support restricts overmodulation depth and prevents thermal management functions from decreasing switching frequency.

Table 13. Power unit settings, Sine filter

Code	Parameter	Min	Max	Unit	Default	ID	Description
P5.6.4.1	Sine filter	0	1		0		0 = Disabled 1 = Enabled

## 2.6.5.5 Keypad

Table 14. I/O and Hardware menu, Keypad parameters

Code	Parameter	Min	Max	Unit	Default	ID	Description
P5.7.1	Timeout time	0	60	min	0		Time after which the display returns to page defined with parameter P5.7.2. 0 = Not used
P5.7.2	Default page	0	4		0		The page the keypad shows when the drive is powered on or when the time defined with P5.7.1 has expired. If the value is set to 0 the page last visited is shown. 0 = None 1 = Enter menu index 2 = Main menu 3 = Control page 4 = Multimonitor
P5.7.3	Menu index						Set menu index for desired page and activate with parameter P5.7.2 = 1.
P5.7.4	Contrast*	30	70	%	50		Set contrast of the display (30...70%).
P5.7.5	Backlight time	0	60	min	5		Set the time until the back-light of the display turns off (0...60 min). If set to 0, back-light is always on.

\*. Only available with graphical keypad

2.6.5.6 Fieldbus

Parameters related to different fieldbus boards can also be found in the *I/O and Hardware* menu. These parameters are explained in more detail in the respective fieldbus manual.

Table 15.

Submenu level 1	Submenu level 2	Submenu level 3	Submenu level 4	
<b>RS-485</b>	Common settings	Protocol	NA	
<b>Ethernet</b>	Common settings	IP address mode	NA	
		IP address	NA	
		Subnet mask	NA	
		Default gateway	NA	
		MAC address	NA	
	Modbus/TCP	Common settings	Connection limit	
			Slave address	
			Communication timeout	
	BacNet IP	Settings	Instance number	
			Communication timeout	
			Protocol in use	
			BBMD IP	
			BBMD port	
			Time to live	
		Monitoring	FB protocol status	
Communication status				
Actual instance				
		Control Word		
		Status Word		

### 2.6.6 USER SETTINGS

Table 16. User settings menu, General settings

Code	Parameter	Min	Max	Unit	Default	ID	Description
P6.1	Language selections	Varies	Varies		Varies	802	Depends on language package.
P6.2	Application selection					801	Select the application to be used.
M6.5	Parameter backup	See chapter 2.6.6.1 below.					
M6.6	Parameter compare						
P6.7	Drive name						Give name of drive if needed.

#### 2.6.6.1 Parameter backup

Table 17. User settings menu, Parameter backup parameters

Code	Parameter	Min	Max	Unit	Default	ID	Description
P6.5.1	Restore factory defaults					831	Restores default parameter values and initiates the Startup Wizard when activated
P6.5.2	Save to keypad*	0	1		0		Save parameter values to keypad to e.g. copy them to another drive. 0 = No 1 = Yes
P6.5.3	Restore from keypad*						Load parameter values from keypad to the drive.
B6.5.4	Save to Set 1						Store a customised parameter set (all parameters included in the application)
B6.5.5	Restore from Set 1						Load the customised parameter set to the drive.
B6.5.6	Save to Set 2						Store another customised parameter set (all parameters included in the application)
B6.5.7	Restore from Set 2						Load the customised parameter set 2 to the drive.

\*. Only available with graphical keypad

### 2.6.7 FAVORITES

**NOTE:** This menu is not available in text keypad.

Favorites are typically used to collect a set of parameters or monitoring signals from any of the keypad menus. You can add items or parameters to the Favorites folder, see chapter 2.4.1.7.

To remove an item or a parameter from the Favorites folder, do the following:

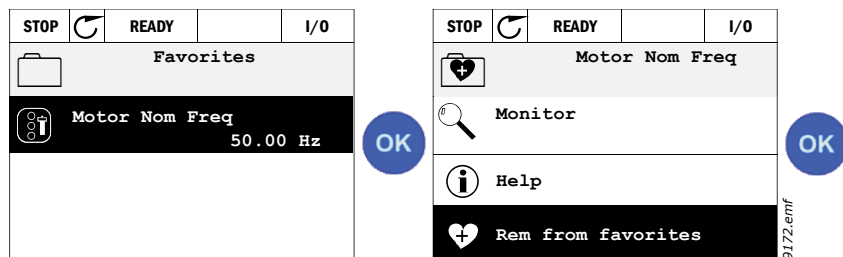

### 2.6.8 USER LEVELS

User level parameters are intended to restrict the visibility of parameters and to prevent unauthorized and inadvertent parameterization on the keypad.

Table 18. User level parameters

Code	Parameter	Min	Max	Unit	Default	ID	Description
P8.1	User level	1	3		1	1194	1 = Normal; All menus visible in the Main menu 2 = Monitoring; Only Monitor, and User Levels menus are visible in the main menu 3 = Favorites; Only Favorites and User Levels menus are visible in the Main menu
P8.2	Access code	0	99999		0	2362	If set to other value than 0 before switching to monitoring when e.g. user level <i>Normal</i> is active, the access code will be asked when trying to switch back to <i>Normal</i> . Can therefore be used to prevent unauthorized parameterization on the keypad. <b>NOTE!</b> Do not lose the code! If the code is lost, please contact the nearest service center/partner.

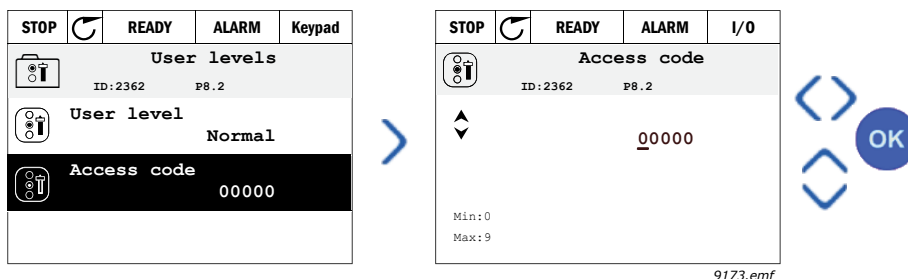



## 3. VACON 100 APPLICATION

The Vacon AC drive contains a preloaded Vacon 100 application for instant use.

The parameters of this application are listed in chapter 3.4.13 of this manual and explained in more detail in chapter 3.5.

### 3.1 SPECIFIC FUNCTIONS OF VACON AC DRIVE

#### Features

- **Extensive wizards** for start-up, PID-control, Multi-pump and Fire Mode used to facilitate commissioning
- **'Funct' button** for easy change between Local (keypad) and Remote control place. The remote control place is selectable by parameter (I/O or Fieldbus)
- **8 preset frequencies**
- **Motor potentiometer** functions
- **Joystick control**
- **Jogging function**
- 2 programmable **ramp times**, 2 **supervisions** and 3 ranges of **prohibited frequencies**
- **Forced stop**
- **Control page** for easy operation and monitoring of the most essential values.
- **Fieldbus** data mapping
- **Automatic reset**
- Different **pre-heat modes** used to avoid condensation problems
- **Maximum output frequency 320Hz**
- **Real-time clock and timer functions** available (optional battery required). Possible to program 3 time channels to achieve different functions on the drive (e.g. Start/Stop and Preset frequencies)
- **External PID-controller** available. Can be used to control e.g. a valve using the AC drive's I/O
- **Sleep mode function** which automatically enables and disables drive running with user defined levels to save energy.
- **2-zone PID-controller** (2 different feedback signals; minimum and maximum control)
- **Two setpoint sources** for the PID-control. Selectable with digital input
- **PID setpoint boost function**
- **Feedforward function** to improve the response to the process changes
- **Process value supervision**
- **Multi-Pump control**
- **Maintenance** counter
- **Pump control functions:** Priming Pump Control, Jockey Pump Control, Pump Impeller Auto-Cleaning, Pump Input Pressure Supervision and Frost Protection function

### 3.2 CONTROL CONNECTIONS, FACTORY SETTINGS

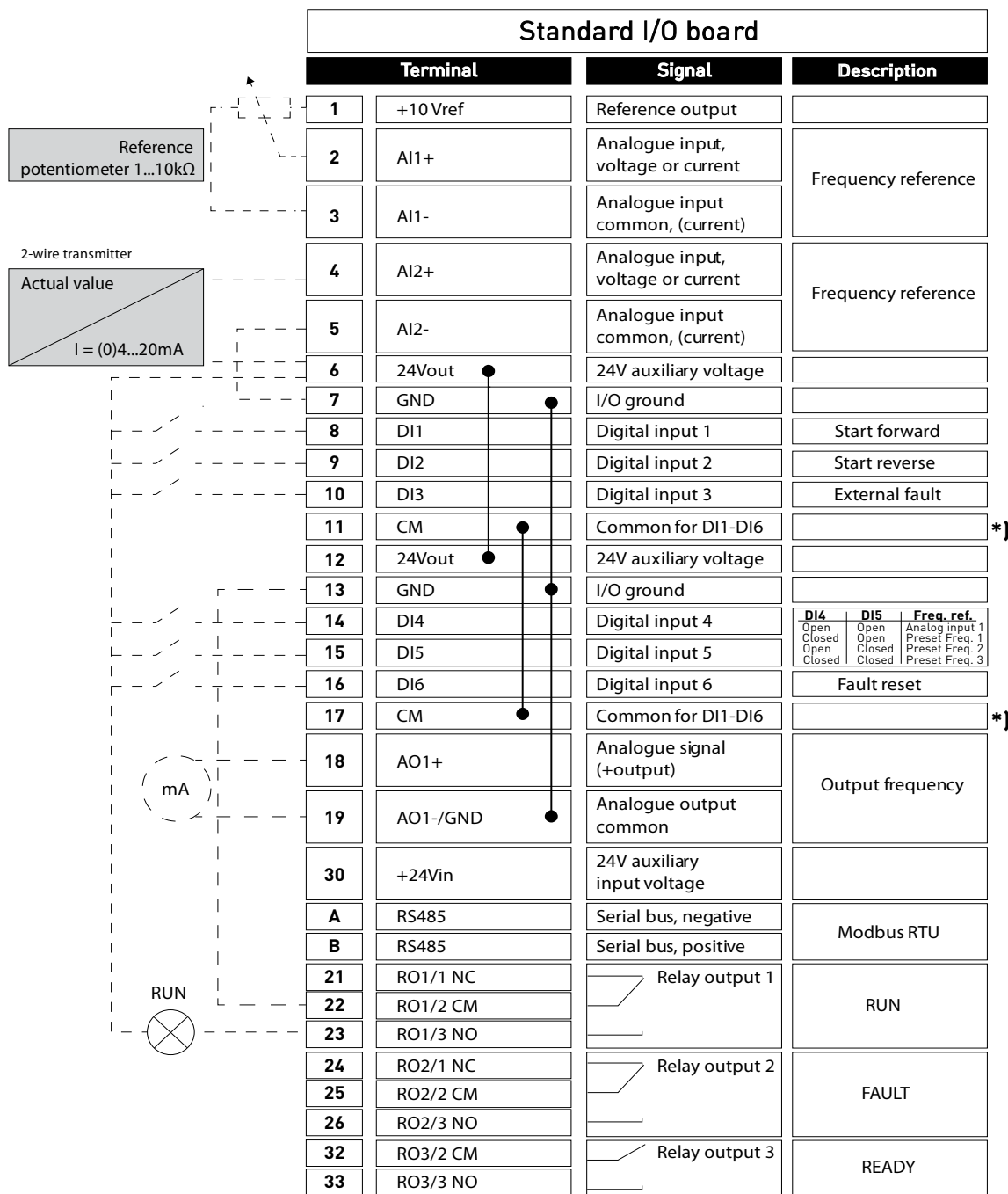

9111.emf

\* ) Digital inputs can be isolated from the ground with a DIP switch, see figure below:

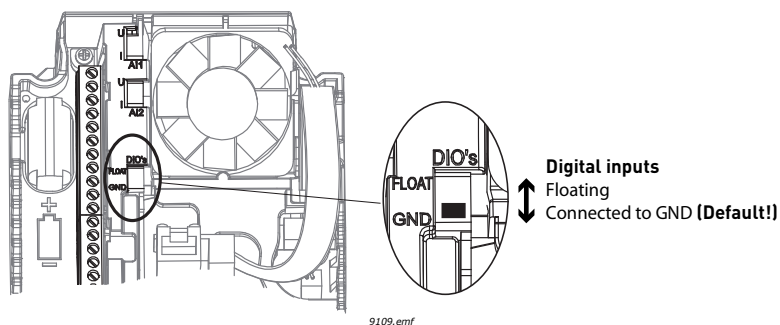

9109.emf

### 3.3 QUICK SETUP PARAMETER GROUP

The Quick Setup parameter group is a collection of parameters that are most commonly used during installation and commissioning. They are collected in the first parameter group so that they can be found fast and easily. They can, however, be also reached and edited in their actual parameter groups. Changing a parameter value in the Quick setup group also changes the value of this parameter in its actual group

In the Quick Setup parameter group you will find the different wizards of the Vacon 100 Application. The wizards help you to quickly set up your drive for use prompting you for a number of essential data.

Table 19. Quick setup parameter group, wizards

Code	Parameter	Min	Max	Unit	Default	ID	Description
1.1.1	I/O Configuration wizard	0	1		0	1673	0 = Do not activate 1 = Activate Choosing <b>Activate</b> initiates the IO configuration Wizard (see chapter 1.2)
1.1.2	Startup wizard	0	1		0	1170	0 = Do not activate 1 = Activate Choosing <b>Activate</b> initiates the Startup Wizard (see chapter 1.1).
1.1.3	PID Mini-Wizard	0	1		0	1670	Choosing <b>Activate</b> initiates the PID Mini-Wizard (see chapter 1.3).
1.1.4	Multi-pump Wizard	0	1		0	1671	Choosing <b>Activate</b> initiates the Multi-pump Wizard (see chapter 1.4).
1.1.5	Fire mode Wizard	0	1		0	1672	Choosing <b>Activate</b> initiates the Fire mode Wizard (see chapter 1.5).

Table 20. Quick setup parameter group, parameters

Code	Parameter	Min	Max	Unit	Default	ID	Description
1.2	Motor Nominal Voltage	0,0	20,0	V	0.0	110	Find this value $U_n$ on the rating plate of the motor. Note also used connection (Delta/Star).
1.3	Motor nominal frequency	0.0	2.0	Hz	0.0	111	Find this value $f_n$ on the rating plate of the motor.
1.4	Motor nominal speed	0	1	rpm	0	112	Find this value $n_n$ on the rating plate of the motor.
1.5	Motor nominal current	Varies	Varies	A		113	Find this value $I_n$ on the rating plate of the motor.
1.6	Motor Cos Phi	0.30	1.00			120	Find this value on the rating plate of the motor
1.7	Motor Nominal Power	Varies	Varies	kW/hp		116	Find this value $P_n$ on the rating plate of the motor
1.8	Motor current limit	Varies	Varies	A		107	Maximum motor current from AC drive

Table 20. Quick setup parameter group, parameters

1.9	Minimum frequency reference	0.00	P3.3.1.2	Hz	0.00	101	Minimum allowed frequency reference
1.10	Maximum frequency reference	P3.3.1.1	320.00	Hz	50.00	102	Maximum allowed frequency reference
1.11	Acceleration time 1	0.1	300.0	s	5.0	103	Defines the time required for the output frequency to increase from zero frequency to maximum frequency
1.12	Deceleration time 1	0.1	300.0	s	5.0	104	Defines the time required for the output frequency to increase from maximum frequency to zero frequency
1.13	Remote control place	0	1			172	Selection of remote control place (start/stop). Can be used to change back to remote control from Vacon Live e.g. in case of a broken panel. 0=I/O control 1=Fieldbus control
1.14	I/O control reference A selection	0	9		5	117	Selection of ref source when control place is I/O A 0 = Preset Frequency 0 1 = Keypad reference 2 = Fieldbus 3 = AI1 4 = AI2 5 = AI1+AI2 6 = PID 1 reference 7 = Motor potentiometer 8 = Joystick reference 9 = Jogging reference
1.15	Preset frequency 1	P3.3.1.1	P3.3.1.2	Hz	10.00	105	Select with digital input: Preset frequency selection 0 (P3.3.3.10)
1.16	Preset frequency 2	P3.3.1.1	P3.3.1.2	Hz	15.00	106	Select with digital input: Preset frequency selection 1 (P3.3.3.11)



### 3.4 MONITOR GROUP

Vacon 100 AC drive provides you with a possibility to monitor the actual values of parameters and signals as well as statuses and measurements. Some of the values to be monitored are customizable.

#### 3.4.1 MULTIMONITOR

On the multi-monitor page, you can collect four to nine values that you wish to monitor. The number of the monitored items can be selected with parameter 3.11.4. See page 26 for more information.

#### 3.4.2 TREND CURVE

The *Trend Curve* feature is a graphical presentation of two monitor values at a time.

Selecting values to monitor starts logging the values. In the Trend curve submenu, you can view the trend curve, make the signal selections, give the minimum and maximum settings, Sampling interval and choose whether to use Autoscaling or not.

Change values to monitor following the procedure below:

1. Locate the *Trend curve* menu in the *Monitor* menu and press OK.
2. Further enter the menu *View trend curve* by pressing OK again.
3. The current selections to monitor are *FreqReference* and *Motor speed* visible at the bottom of the display.
4. Only two values can be monitored as trend curves simultaneously. Select the one of the current values you wish to change with the arrow buttons and press OK.
5. Browse the list of given monitoring values with the arrow buttons, select the one you wish and press OK.
6. The trend curve of the changed value can be seen on the display.

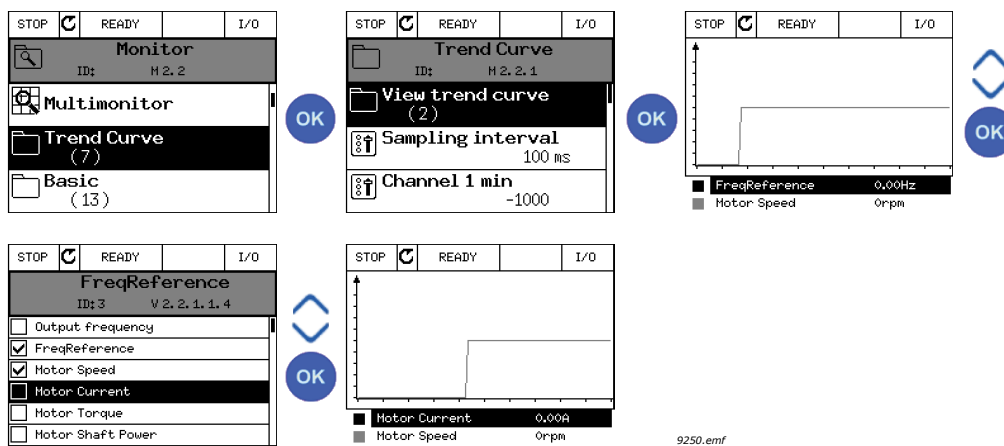

The *Trend Curve* feature also allows you to halt the progression of the curve and read the exact individual values.

1. In Trend curve view, select the display with the arrow button up (the frame of the display turns bold) and press OK at the desired point of the progressing curve. A vertical hairline appears on the display.
2. The display freezes and the values at the bottom of the display correspond to the location of the hairline.
3. Use the arrow buttons left and right to move the hairline to see the exact values of some other location.

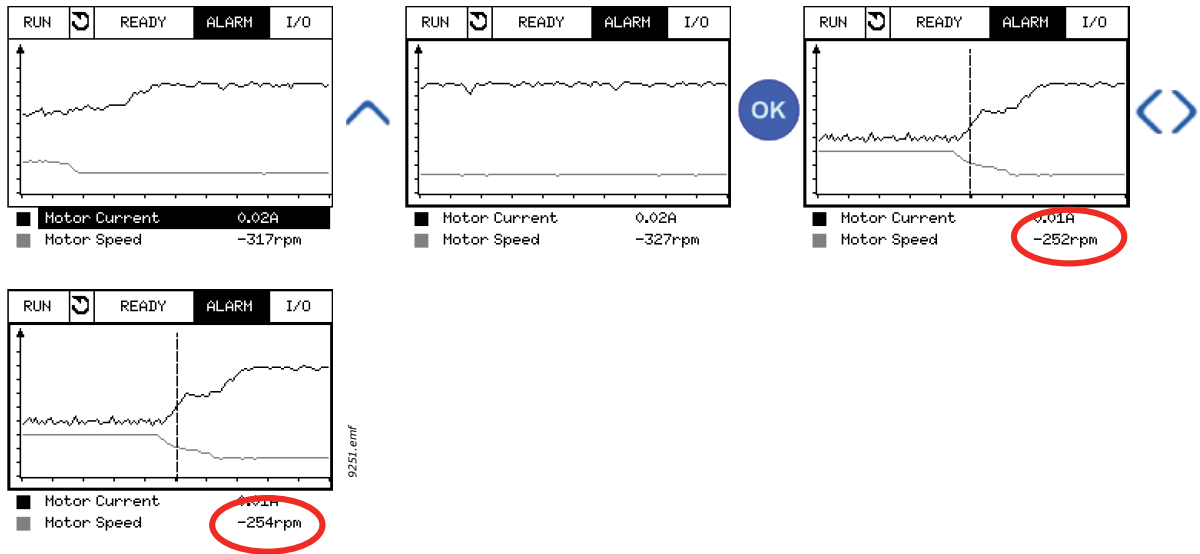

Table 21. Trend curve parameters

Code	Parameter	Min	Max	Unit	Default	ID	Description
M2.2.1	View Trend curve						Enter this menu to select and monitor values for viewing in curve form.
P2.2.2	Sampling interval	100	432000	ms	100	2368	Set here the sampling interval.
P2.2.3	Channel 1 min	-214748	1000		-1000	2369	Used by default for scaling. Adjustments might be necessary.
P2.2.4	Channel 1 max	-1000	214748		1000	2370	Used by default for scaling. Adjustments might be necessary.
P2.2.5	Channel 2 min	-214748	1000		-1000	2371	Used by default for scaling. Adjustments might be necessary.
P2.2.6	Channel 2 max	-1000	214748		1000	2372	Used by default for scaling. Adjustments might be necessary.
P2.2.7	Autoscale	0	1		0	2373	The selected signal is automatically scaled between min and max values if this parameter is given value 1.

**3.4.3 BASIC**

See Table 22 in which the basic monitoring values are presented.

**NOTE!**  
 Only standard I/O board statuses are available in the Monitor menu. Statuses for all I/O board signals can be found as raw data in the I/O and Hardware system menu.  
 Check expander I/O board statuses when required in the I/O and Hardware system menu.

*Table 22. Monitoring menu items*

Code	Monitoring value	Unit	Scale	ID	Description
V2.3.1	Output frequency	Hz	0.01	1	Output frequency to motor
V2.3.2	Frequency reference	Hz	0.01	25	Frequency reference to motor control
V2.3.3	Motor speed	rpm	1	2	Motor actual speed in rpm
V2.3.4	Motor current	A	Varies	3	
V2.3.5	Motor torque	%	0.1	4	Calculated shaft torque
V2.3.7	Motor shaft power	%	0.1	5	Calculated motor shaft power in %
V2.3.8	Motor shaft power	kW/hp	Varies	73	Calculated motor shaft power in kW or hp. Units depends on the unit selection parameter.
V2.3.9	Motor voltage	V	0.1	6	Output voltage to motor
V2.3.10	DC link voltage	V	1	7	Measured voltage in the drive's DC-link
V2.3.11	Unit temperature	°C	0.1	8	Heatsink temperature in °C or °F
V2.3.12	Motor temperature	%	0.1	9	Calculated motor temperature in percent of nominal working temperature.
V2.3.13	Motor Preheat		1	1228	Status of Motor preheat function. 0 = OFF 1 = Heating (feeding DC-current)
V2.3.14	Torque reference	%	0.1	18	Final torque reference to motor control.

## 3.4.4 I/O

Table 23. I/O signal monitoring

Code	Monitoring value	Unit	Scale	ID	Description
V2.4.1	Slot A DIN 1, 2, 3		1	15	Shows the status of digital inputs 1-3 in slot A (standard I/O)
V2.4.2	Slot A DIN 4, 5, 6		1	16	Shows the status of digital inputs 4-6 in slot A (standard I/O)
V2.4.3	Slot B RO 1, 2, 3		1	17	Shows the status of relay inputs 1-3 in slot B
V2.4.4	Analogue input 1	%	0.01	59	Input signal in percent of used range. Slot A.1 as default.
V2.4.5	Analogue input 2	%	0.01	60	Input signal in percent of used range. Slot A.2 as default.
V2.4.6	Analogue input 3	%	0.01	61	Input signal in percent of used range. Slot D.1 as default.
V2.4.7	Analogue input 4	%	0.01	62	Input signal in percent of used range. Slot D.2 as default.
V2.4.8	Analogue input 5	%	0.01	75	Input signal in percent of used range. Slot E.1 as default.
V2.4.9	Analogue input 6	%	0.01	76	Input signal in percent of used range. Slot E.2 as default.
V2.4.10	Slot A A01	%	0.01	81	Analog output signal in percent of used range. Slot A (standard I/O)

## 3.4.5 TEMPERATURE INPUTS

**NOTE!** This parameter group is visible only with an option board for temperature measurement (OPT-BH) installed.

Table 24. Monitored values of temperature inputs

Code	Monitoring value	Unit	Scale	ID	Description
V2.5.1	Temperature input 1	°C	0.1	50	Measured value of Temperature input 1. The list of temperature inputs is formed of 6 first available temperature inputs starting from slot A continuing to slot E. If the input is available but no sensor is connected the maximum value is shown because measured resistance is endless. The value can be forced to its min value instead by hardwiring the input.
V2.5.2	Temperature input 2	°C	0.1	51	Measured value of Temperature input 2. See above.
V2.5.3	Temperature input 3	°C	0.1	52	Measured value of Temperature input 3. See above.
V2.5.4	Temperature input 4	°C	0.1	69	Measured value of Temperature input 4. See above.
V2.5.5	Temperature input 5	°C	0.1	70	Measured value of Temperature input 5. See above.
V2.5.6	Temperature input 6	°C	0.1	71	Measured value of Temperature input 6. See above.



3.4.6 EXTRAS & ADVANCED

Table 25. Advanced values monitoring

Code	Monitoring value	Unit	Scale	ID	Description
V2.6.1	Drive Status Word		1	43	Bit coded word B1=Ready B2=Run B3=Fault B6=RunEnable B7=AlarmActive B10=DC Current in stop B11=DC Brake Active B12=RunRequest B13=MotorRegulatorActive
V2.6.2	Ready status		1	78	Bit coded information about ready criteria. Useful for debugging when the drive is not in ready status. Values are visible as checkboxes on graphical keypad. If checked (☑), the value is active. B0: RunEnable high B1: No fault active B2: Charge switch closed B3: DC voltage within limits B4: Power manager initialized B5: Power unit is not blocking start B6: System software is not blocking start
V2.6.3	Application Status Word1		1	89	Bit coded statuses of application. Values are visible as checkboxes on graphical keypad. If checked (☑), the value is active. B0=Interlock 1 B1=Interlock 2 B2=Reserved B3=Ramp 2 active B4=Mechanical brake control B5=I/O A control active B6=I/O B control active B7=Fieldbus Control Active B8=Local control active B9=PC control active B10=Preset frequencies active B11=Jogging active B12=Fire Mode active B13=Motor Preheat active B14=Quick stop active B15=Drive stopped from keypad
V2.6.4	Application Status Word2		1	90	Bit coded status of application. Values are visible as checkboxes on graphical keypad. If checked (☑), the value is active. B0=Acc/Dec prohibited B1=Motor switch open B5=Jockey pump active B6=Priming pump active B7=Input pressure supervision (Alarm/Fault) B8=Frost protection (Alarm/Fault) B9=Autocleaning active

Table 25. Advanced values monitoring

Code	Monitoring value	Unit	Scale	ID	Description
V2.6.5	DIN Status Word 1		1	56	16-bit word where each bit represents the status of one digital input. 6 digital inputs from every slot are read. Word 1 starts from input 1 in slot A (bit0) and goes all the way to input 4 in slot C (bit15).
V2.6.6	DIN Status Word 2		1	57	16-bit word where each bit represents the status of one digital input. 6 digital inputs from every slot are read. Word 1 starts from input 5 in slot C (bit0) and goes all the way to input 6 in slot E (bit13).
V2.6.7	Motor current 1 decimal		0.1	45	Motor current monitor value with fixed number of decimals and less filtering. Can be used e.g. for fieldbus purposes to always get the right value regardless of frame size, or for monitoring when less filtering time is needed for the motor current.
V2.6.8	Frequency reference source		1	1495	Shows the momentary frequency reference source. 0=PC 1=Preset Freqs 2=Keypad Reference 3=Fieldbus 4=AI1 5=AI2 6=AI1+AI2 7=PID Controller 8=Motor Potentiom. 9=Joystick 10=Jogging 100=Not defined 101=Alarm,PresetFreq 102=Autocleaning
V2.6.9	Last active fault code		1	37	The fault code of latest activated fault that has not been reset.
V2.6.10	Last active fault ID		1	95	The fault ID of latest activated fault that has not been reset.
V2.6.11	Last active alarm code		1	74	The alarm code of latest activated alarm that has not been reset.
V2.6.12	Last active alarm ID		1	94	The alarm ID of latest activated alarm that has not been reset.

### 3.4.7 TIMER FUNCTIONS MONITORING

Here you can monitor values of timer functions and the Real Time Clock.

Table 26. Monitoring of timer functions

Code	Monitoring value	Unit	Scale	ID	Description
V2.7.1	TC 1, TC 2, TC 3		1	1441	Possible to monitor the statuses of the three Time Channels (TC)
V2.7.2	Interval 1		1	1442	Status of timer interval
V2.7.3	Interval 2		1	1443	Status of timer interval
V2.7.4	Interval 3		1	1444	Status of timer interval
V2.7.5	Interval 4		1	1445	Status of timer interval
V2.7.6	Interval 5		1	1446	Status of timer interval
V2.7.7	Timer 1	s	1	1447	Remaining time on timer if active
V2.7.8	Timer 2	s	1	1448	Remaining time on timer if active
V2.7.9	Timer 3	s	1	1449	Remaining time on timer if active
V2.7.10	Real time clock			1450	hh:mm:ss

### 3.4.8 PID-CONTROLLER MONITORING

Table 27. PID-controller value monitoring

Code	Monitoring value	Unit	Scale	ID	Description
V2.8.1	PID1 setpoint	Varies	According to P3.13.1.7	20	PID controller setpoint value in process units. Process unit is selected with a parameter.
V2.8.2	PID1 feedback	Varies	According to P3.13.1.7	21	PID controller feedback value in process units. Process unit is selected with a parameter.
V2.8.3	PID1 error value	Varies	According to P3.13.1.7	22	PID controller error value. Deviation of feedback from setpoint in process units. Process unit is selected with a parameter.
V2.8.4	PID1 output	%	0.01	23	PID output in percent (0..100%). This value can be fed e.g. to Motor Control (Frequency reference) or Analogue output
V2.8.5	PID1 status		1	24	0=Stopped 1=Running 3=Sleep mode 4=In dead band (see page 104)

### 3.4.9 EXTERNAL PID-CONTROLLER MONITORING

Table 28. External PID-controller value monitoring

Code	Monitoring value	Unit	Scale	ID	Description
V2.9.1	ExtPID setpoint	Varies	According to P3.14.1.10	83	External PID controller setpoint value in process units. Process unit is selected with a parameter.
V2.9.2	ExtPID feedback	Varies	According to P3.14.1.10	84	External PID controller feedback value in process units. Process unit is selected with a parameter.
V2.9.3	ExtPID error value	Varies	According to P3.14.1.10	85	External PID controller Error value. Deviation of feedback from setpoint in process units. Process unit is selected with a parameter.
V2.9.4	ExtPID output	%	0.01	86	External PID controller output in percent (0..100%). This value can be fed e.g. to Analogue output.
V2.9.5	ExtPID status		1	87	0=Stopped 1=Running 2=In dead band (see page 104)

### 3.4.10 MULTI-PUMP MONITORING

Table 29. Multi-pump monitoring

Code	Monitoring value	Unit	Scale	ID	Description
V2.10.1	Motors running		1	30	The number of motors running when Multi-Pump function is used.
V2.10.2	Autochange		1	1113	Informs the user if autochange is requested.

### 3.4.11 MAINTENANCE COUNTERS

Table 30. Maintenance counter monitoring

Code	Monitoring value	Unit	Scale	ID	Description
V2.11.1	Maintenance counter 1	h/ kRev	Varies	1101	Status of maintenance counter in revolutions multiplied by 1000, or hours. For configuration and activation of this counter, see chapter Group 3.16: Maintenance counters on page 121.

3.4.12 FIELDBUS DATA MONITORING

Table 31. Fieldbus data monitoring

Code	Monitoring value	Unit	Scale	ID	Description
V2.12.1	FB Control Word		1	874	Fieldbus control word used by application in bypass mode/format. Depending on the fieldbus type or profile the data can be modified before sent to application.
V2.12.2	FB speed reference		Varies	875	Speed reference scaled between minimum and maximum frequency at the moment it was received by the application. Minimum and maximum frequencies can be changed after the reference was received without affecting the reference.
V2.12.3	FB data in 1		1	876	Raw value of process data in 32-bit signed format
V2.12.4	FB data in 2		1	877	Raw value of process data in 32-bit signed format
V2.12.5	FB data in 3		1	878	Raw value of process data in 32-bit signed format
V2.12.6	FB data in 4		1	879	Raw value of process data in 32-bit signed format
V2.12.7	FB data in 5		1	880	Raw value of process data in 32-bit signed format
V2.12.8	FB data in 6		1	881	Raw value of process data in 32-bit signed format
V2.12.9	FB data in 7		1	882	Raw value of process data in 32-bit signed format
V2.12.10	FB data in 8		1	883	Raw value of process data in 32-bit signed format
V2.12.11	FB Status Word		1	864	Fieldbus status word sent by application in bypass mode/format. Depending on the FB type or profile the data can be modified before sent to the FB.
V2.12.12	FB speed actual		0.01	865	Actual speed in %. 0 and 100% correspond to minimum and maximum frequencies respectively. This is continuously updated depending on the momentary min and max frequencies and the output frequency.
V2.12.13	FB data out 1		1	866	Raw value of process data in 32-bit signed format
V2.12.14	FB data out 2		1	867	Raw value of process data in 32-bit signed format
V2.12.15	FB data out 3		1	868	Raw value of process data in 32-bit signed format
V2.12.16	FB data out 4		1	869	Raw value of process data in 32-bit signed format
V2.12.17	FB data out 5		1	870	Raw value of process data in 32-bit signed format
V2.12.18	FB data out 6		1	871	Raw value of process data in 32-bit signed format
V2.12.19	FB data out 7		1	872	Raw value of process data in 32-bit signed format
V2.12.20	FB data out 8		1	873	Raw value of process data in 32-bit signed format

**3.4.13 PROGRAMMING OF DIGITAL AND ANALOGUE INPUTS**

The programming of inputs in the Vacon 100 General-Purpose Application is very flexible. The available inputs on the standard and optional I/O can be used for various functions according to the operator's choice.

The available I/O can be expanded with optional boards to be inserted in board slots C, D and E. More information about the installation of optional boards you will find in the Installation manual.

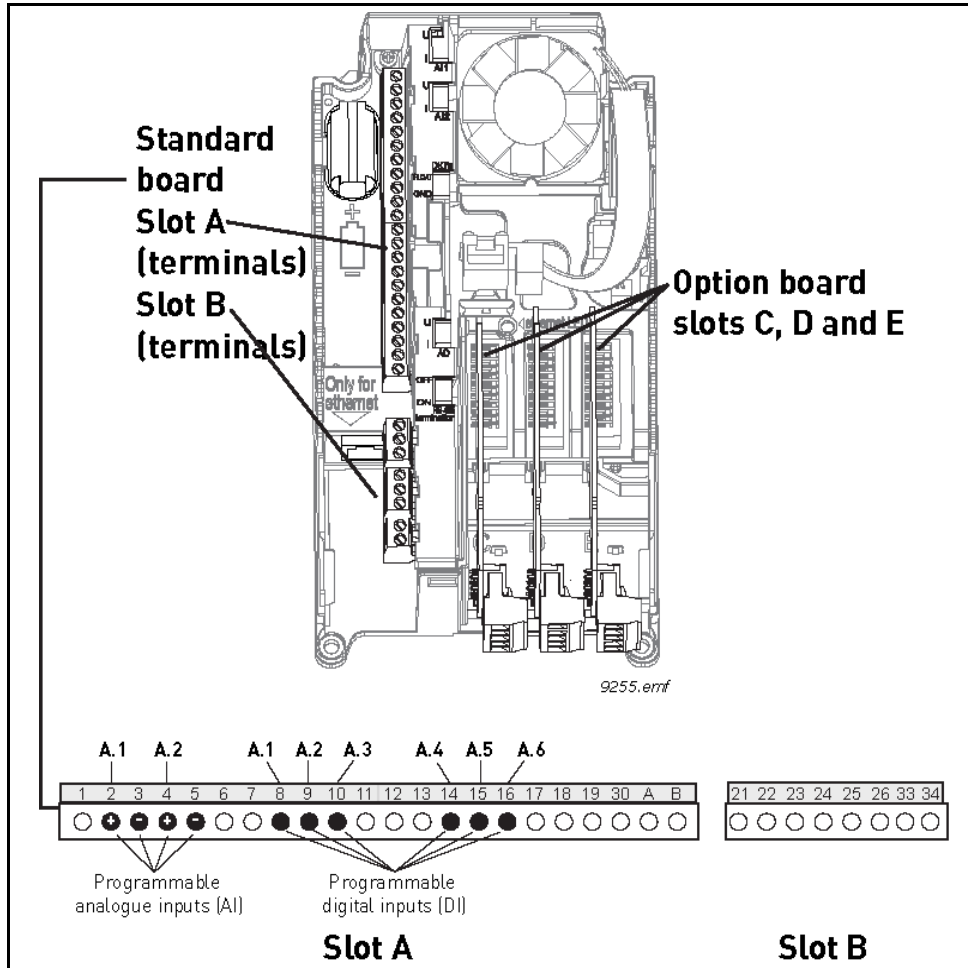

Figure 16. Board slots and programmable inputs

3.4.13.1 Digital inputs

The applicable functions for digital inputs are arranged as parameters in parameter group M3.5.1. The value given to the parameter is a reference to the digital input you choose to use for the function. The list of functions that you can assign to the available digital inputs is presented on page 77.

Example

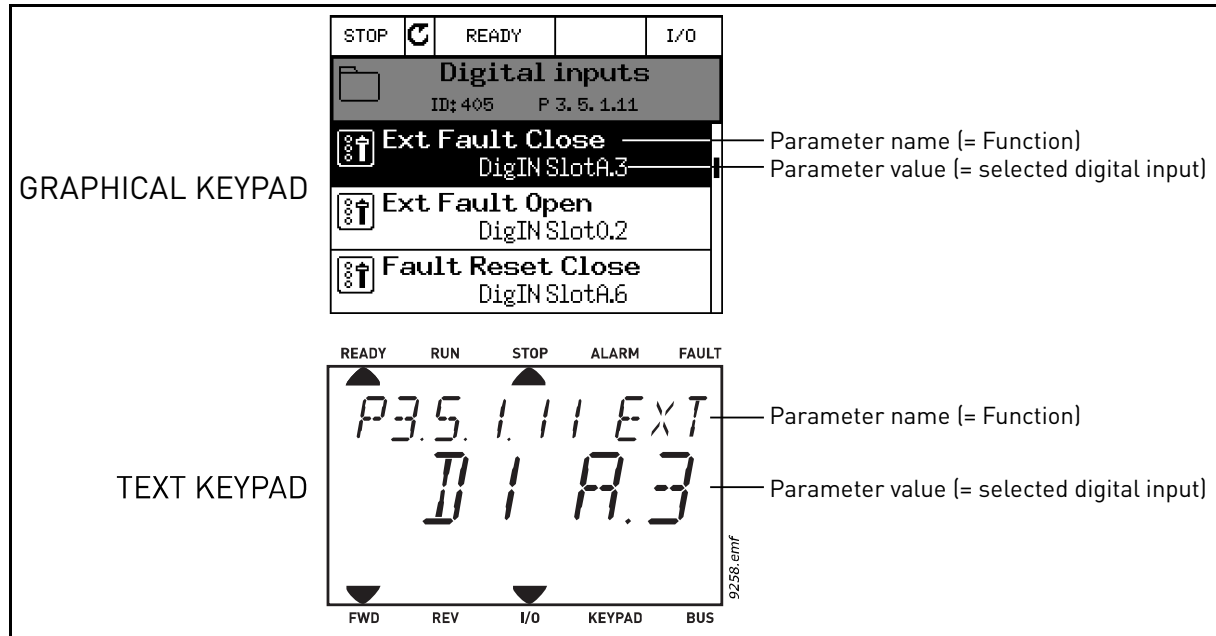

Figure 17.

Given the standard I/O board compilation on the Vacon 100 AC drive, there are 6 digital inputs available (Slot A terminals 8, 9, 10, 14, 15 and 16). In the programming view, these inputs are referred to as follows:

Table 32.

Input type (Graphical keypad)	Input type (Text keypad)	Slot	Input #	Explanation
DigIN	dl	A.	1	Digital input #1 (terminal 8) on board in Slot A (standard I/O board).
DigIN	dl	A.	2	Digital input #2 (terminal 9) on board in Slot A (standard I/O board).
DigIN	dl	A.	3	Digital input #3 (terminal 10) on board in Slot A (standard I/O board).
DigIN	dl	A.	4	Digital input #4 (terminal 14) on board in Slot A (standard I/O board).
DigIN	dl	A.	5	Digital input #5 (terminal 15) on board in Slot A (standard I/O board).
DigIN	dl	A.	6	Digital input #6 (terminal 16) on board in Slot A (standard I/O board).

In the example 17, the function *External fault close* located in menu M3.5.1 as parameter P3.5.1.11, is by default given the value *DigIN SlotA.3* (graphical keypad) or *dI A.3* (text keypad).

This means that the function *External fault close* is now controlled with a digital signal to digital input DI3 (terminal 10).

This is what is shown in the parameter list on page 77.

Code	Parameter	Default	ID	Description
P3.5.1.11	External fault close	DigIN SlotA.3	405	FALSE = OK TRUE = External fault

Assume you need to change the selected input. Instead of DI3 you wish to use DI6 (terminal 16) on the standard I/O. Do as instructed here:

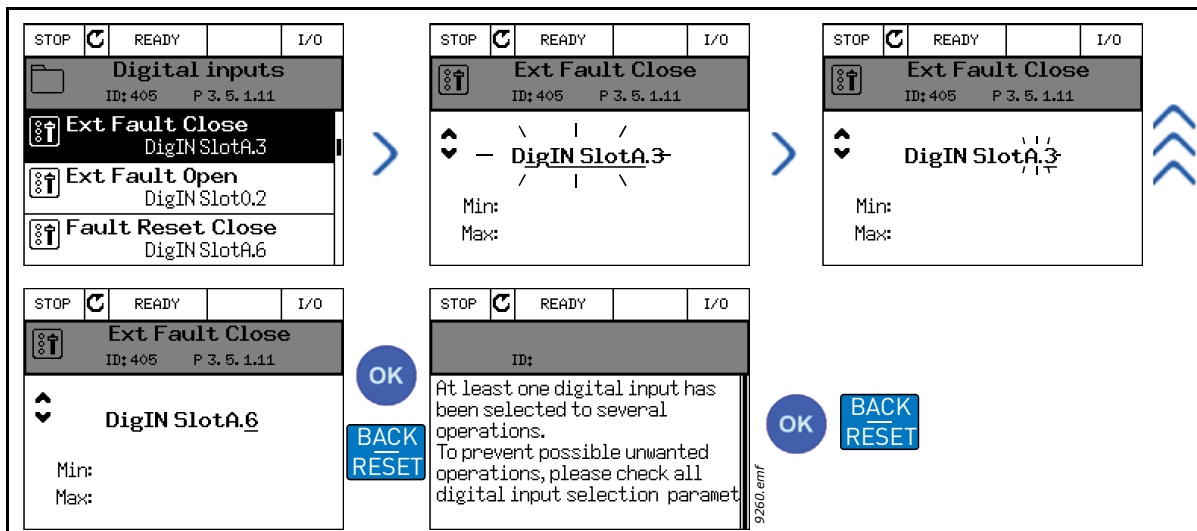

Figure 18. Programming digital inputs with graphical keypad

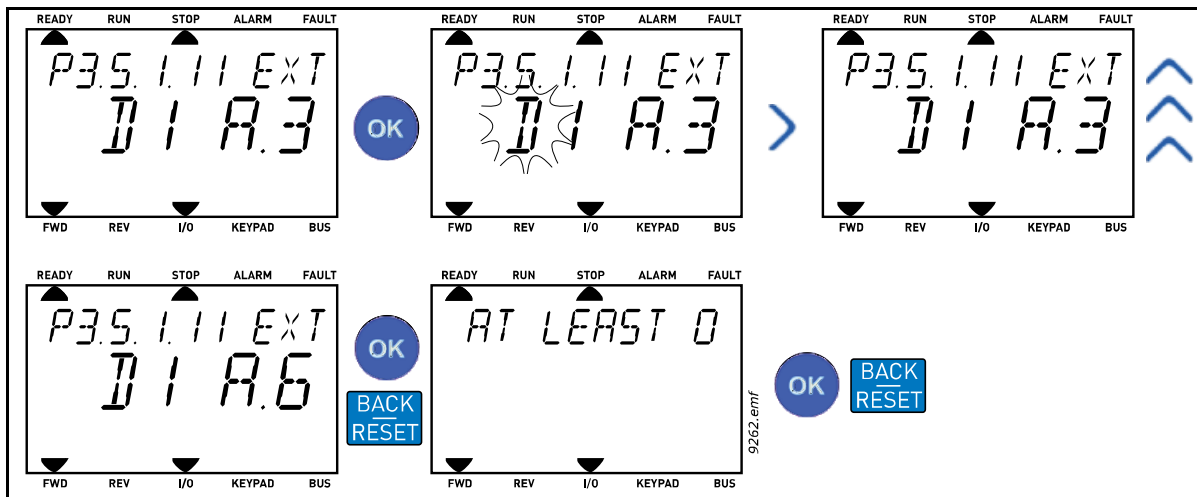

Figure 19. Programming digital inputs with text keypad



Table 33. Programming digital inputs

PROGRAMMING INSTRUCTIONS	
Graphical keypad	Text keypad
1. Select the parameter and push the <i>Arrow right</i> button.	1. Select the parameter and push the <i>OK</i> button.
2. You are now in the <i>Edit</i> mode as the slot value <i>DigIN SlotA.</i> is blinking and underlined. (Should you have more digital inputs available in your I/O, for example, through inserted option boards in slots <b>C</b> , <b>D</b> or <b>E</b> , they can also be selected here.). See 16.	2. You are now in the <i>Edit</i> mode as the letter <i>d</i> is blinking. (Should you have more digital inputs available in your I/O, for example, through inserted option boards in slots <b>C</b> , <b>D</b> or <b>E</b> , they can also be selected here.). See 16.
3. Push the <i>Arrow right</i> button again to activate the terminal value 3.	3. Push the <i>Arrow right</i> button to activate the terminal value 3. The letter <i>d</i> stops blinking.
4. Push the <i>Arrow up</i> button three times to change the terminal value to 6. Confirm with <i>OK</i> button.	4. Push the <i>Arrow up</i> button three times to change the terminal value to 6. Confirm with <i>OK</i> button.
5. <b>NOTE!</b> If the digital input DI6 was already used for some other function a message is displayed. You might then want to change either of these selections.	5. <b>NOTE!</b> If the digital input DI6 was already used for some other function a message will scroll through the display. You might then want to change either of these selections.

Now, the function *External fault close* is controlled with a digital signal to digital input DI6 (terminal 16).

<b>NOTE!</b>	The function is not assigned to any terminal, or, the the input is set to be always FALSE, if its value is <i>DigIN Slot0.1</i> (graphical keypad) or <i>dI 0.1</i> (text keypad). This is the default value of the majority of parameters in group M3.5.1.  On the other hand, some inputs have been by default set to be always TRUE. Their value shows <i>DigIN Slot0.2</i> (graphical keypad) or <i>dI 0.2</i> (text keypad).
<b>NOTE!</b>	Also <i>Time Channels</i> can be assigned to digital inputs. See more information on page 98.

3.4.13.2 Analogue inputs

The target input for the analogue frequency reference signal can also be chosen from the available analogue inputs.

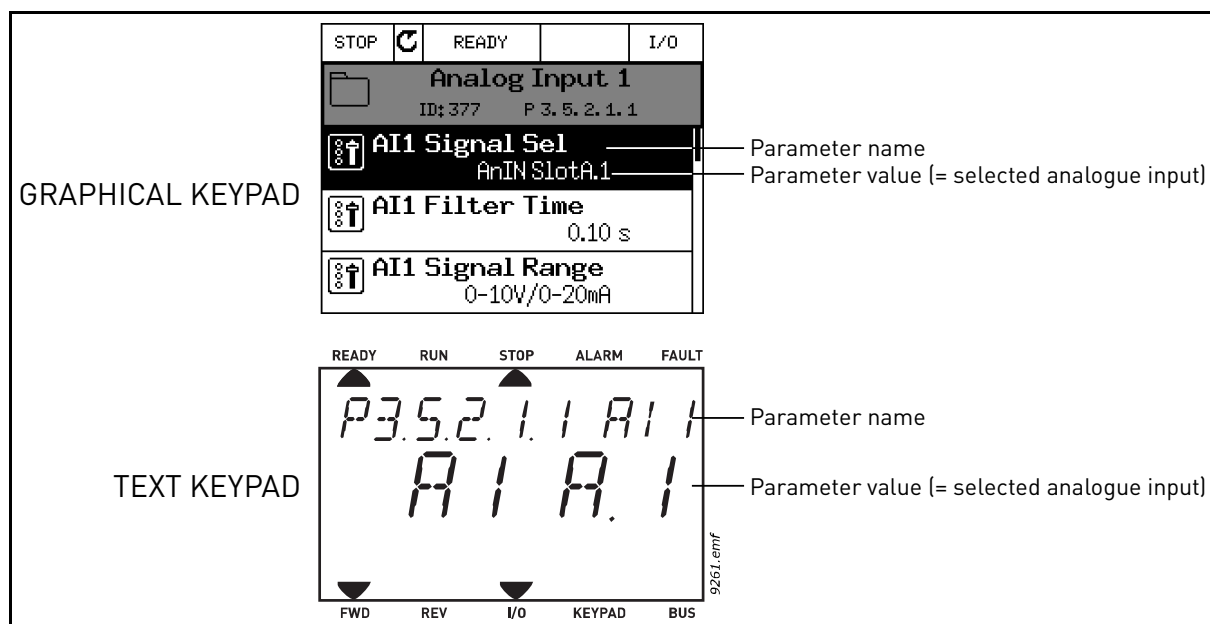

Figure 20.

Given the standard I/O board compilation on the Vacon 100 AC drive, there are 2 analogue inputs available (Slot A terminals 2/3 and 4/5). In the programming view, these inputs are referred to as follows:

Table 34. Programming analogue inputs

Input type (Graphical keypad)	Input type (Text keypad)	Slot	Input #	Explanation
AnIN	AI	A.	1	Analogue input #1 (terminals 2/3) on board in Slot A (standard I/O board).
AnIN	AI	A.	2	Analogue input #2 (terminals 4/5) on board in Slot A (standard I/O board).

In the example 20, the parameter *AI1 signal selection* located in menu M3.5.2.1 with parameter code P3.5.2.1.1, is by default given the value *AnIN SlotA.1* (graphical keypad) or *AI A.1* (text keypad). This means that the target input for the analogue frequency reference signal AI1 is now the analogue input in terminals 2/3. Whether the signal is voltage or current, must be determined with the *dip switches*. See the Installation manual for more information.

This is what is shown in the parameter list on page 80:

Code	Parameter	Min	Max	Unit	Default	ID	Description
P3.5.2.1.1	AI1 signal selection				AnIN SlotA.1	377	Connect the AI1 signal to the analogue input of your choice with this parameter. Programmable. See page 51.

Assume you need to change the selected input. Instead of AI1 you wish to use the analogue input on your option board in slot C. Do as instructed here:

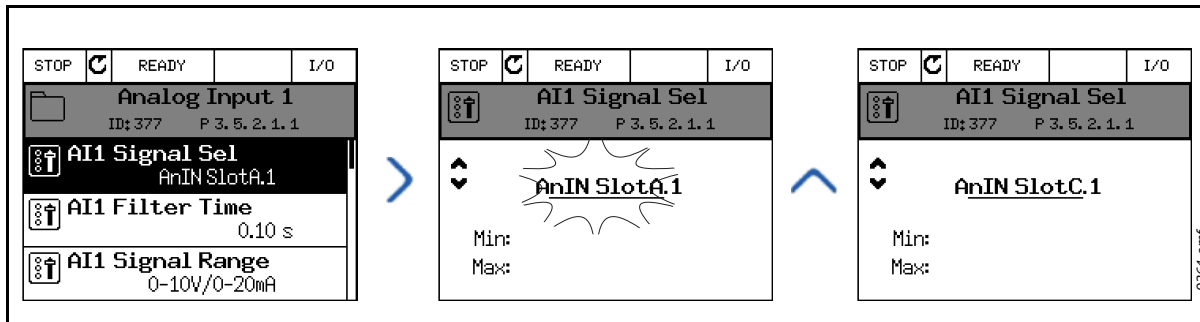

Figure 21. Programming analogue inputs with graphical keypad

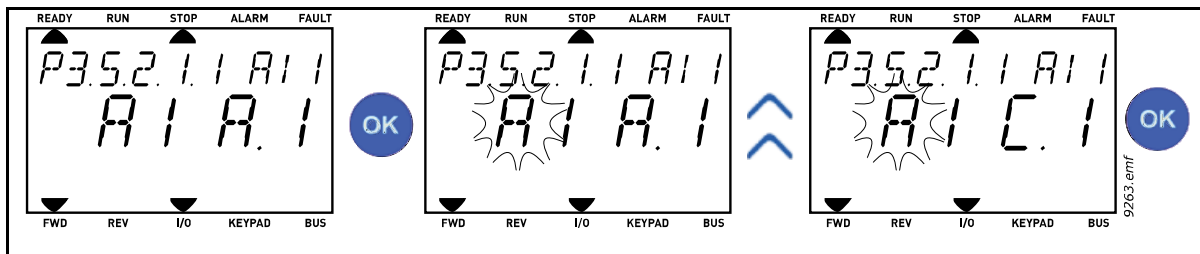

Figure 22. Programming analogue inputs with text keypad

PROGRAMMING INSTRUCTIONS	
Graphical keypad	Text keypad
1. Select the parameter and push the <i>Arrow right</i> button.	1. Select the parameter and push the <i>OK</i> button.
2. You are now in the <i>Edit</i> mode as the slot value <i>AnIN SlotA.</i> is blinking and underlined.	2. You are now in the <i>Edit</i> mode as the letter <i>A</i> is blinking.
3. Push the <i>Arrow up</i> button once to change the slot value to <i>AnIN SlotC.</i> Confirm with <i>OK</i> button.	3. Push the <i>Arrow up</i> button once to change the slot value to <i>C.</i> Confirm with <i>OK</i> button.

3.4.13.3 Descriptions of signal sources

Table 35. Descriptions of signal sources

Source	Function
Slot0.#	<p><b>Digital inputs:</b>                      A digital signal can be forced to a constant FALSE or TRUE state using this functionality.                      For example, some signals have been set to be always in TRUE state by manufacturer, e.g parameter P3.5.1.15 (Run enable). Unless changed, Run enable signal is always on.                      # = 1: Always FALSE                      # = 2-10: Always TRUE</p> <p><b>Analogue inputs</b> (used for testing purposes):                      # = 1: Analogue input = 0% signal strength                      # = 2: Analogue input = 20% signal strength                      # = 3: Analogue input = 30% signal strength                      etc.                      # = 10: Analogue input = 100% signal strength</p>
SlotA.#	Number (#) corresponds to digital input in slot A.
SlotB.#	Number (#) corresponds to digital input in slot B.
SlotC.#	Number (#) corresponds to digital input in slot C.
SlotD.#	Number (#) corresponds to digital input in slot D.
SlotE.#	Number (#) corresponds to digital input in slot E.
TimeChannel.#	Number (#) corresponds to: 1=Time Channel1, 2=Time Channel2, 3=Time Channel3
Fieldbus CW.#	Number (#) refers to Control Word bit number.
FieldbusPD.#	Number (#) refers to Process Data 1 bit number.

3.4.13.4 Default assignments of digital and analogue inputs in Vacon 100 application

Digital and analogue inputs are assigned certain functions by the factory. In this application, the default assignments are:

Table 36. Default assignments of inputs

Input	Terminal(s)	Reference	Assigned function	Parameter code
D11	8	A.1	Control signal 1 A	P3.5.1.1
D12	9	A.2	Control signal 2 A	P3.5.1.2
D13	10	A.3	External fault close	P3.5.1.11
D14	14	A.4	Preset frequency selection 0	P3.5.1.21
D15	15	A.5	Preset frequency selection 1	P3.5.1.22
D16	16	A.6	External fault close	P3.5.1.13
A11	2/3	A.1	A11 signal selection	P3.5.2.1.1
A12	4/5	A.2	A12 signal selection	P3.5.2.2.1

**3.4.1.4 GROUP 3.1: MOTOR SETTINGS**

3.4.14.1 Group 3.1.1: Motor nameplate

*Table 37. Motor nameplate parameters*

Code	Parameter	Min	Max	Unit	Default	ID	Description
P3.1.1.1	Motor nominal voltage	Varies	Varies	V	Varies	110	Find this value $U_n$ on the rating plate of the motor. Note also used connection (Delta/Star).
P3.1.1.2	Motor nominal frequency	8.00	320.00	Hz	Varies	111	Find this value $f_n$ on the rating plate of the motor.
P3.1.1.3	Motor nominal speed	24	19200	rpm	Varies	112	Find this value $n_n$ on the rating plate of the motor.
P3.1.1.4	Motor nominal current	Varies	Varies	A	Varies	113	Find this value $I_n$ on the rating plate of the motor.
P3.1.1.5	Motor Cos Phi	0.30	1.00		0.74	120	Find this value on the rating plate of the motor
P3.1.1.6	Motor nominal power	Varies	Varies	kW	Varies	116	Find this value $P_n$ on the rating plate of the motor.

3.4.14.2 Motor Control Settings

*Table 38. Motor control settings*

Code	Parameter	Min	Max	Unit	Default	ID	Description
P3.1.2.1	Control mode	0	2		0	600	0 = U/f Freq ctrl open loop 1 = Speed control open loop 2 = Torque control open loop
P3.1.2.2	Motor type	0	1		0	650	0 = Induction motor 1 = PM motor
P3.1.2.3	Switching frequency	1.5	Varies	kHz	Varies	601	Increasing the switching frequency reduces the capacity of the AC drive. It is recommended to use a lower frequency when the motor cable is long in order to minimize capacitive currents in the cable. Motor noise can also be minimised using a high switching frequency.

Table 38. Motor control settings





Code	Parameter	Min	Max	Unit	Default	ID	Description
 P3.1.2.4	Identification	0	2		0	631	The automatic motor identification calculates or measures the motor parameters that are needed for optimum motor and speed control. 0 = No action 1 = At standstill 2 = With rotation <b>NOTE:</b> Motor nameplate parameters in menu M3.1.1 Motor Nameplate has to be set before executing the identification.
P3.1.2.5	Magnetizing current	0.0	2*I <sub>H</sub>	A	0.0	612	Motor magnetizing current (no-load current). The values of the U/f parameters are identified by the magnetizing current if given before the identification run. If this value is set to zero, magnetizing current will be internally calculated.
 P3.1.2.6	Motor switch	0	1		0	653	Enabling this function prevents the drive from tripping when the motor switch is closed and opened e.g. using flying start. 0 = Disabled 1 = Enabled
 P3.1.2.7	Load drooping	0.00	50.00	%	0.00	620	The drooping function enables speed drop as a function of load. Drooping will be defined in percent of nominal speed at nominal load.
P3.1.2.8	Load drooping time	0.00	2.00	s	0.00	656	Load drooping is used in order to achieve a dynamic speed drooping because of changing load. This parameter defines the time during which the speed is restored to the level it was before the load increase.
P3.1.2.9	Load drooping mode	0	1		0	1534	0 = Normal; Load drooping factor is constant through the whole frequency range 1 = Linear removal; Load drooping is removed linearly from nominal frequency to zero frequency
 P3.1.2.10	Overvoltage control	0	1		1	607	0 = Disabled 1 = Enabled
 P3.1.2.11	Undervoltage control	0	1		1	608	0 = Disabled 1 = Enabled

Table 38. Motor control settings

Code	Parameter	Min	Max	Unit	Default	ID	Description
P3.1.2.12	Energy optimization	0	1		0	666	The drive searches for the minimum motor current in order to save energy and to lower the motor noise. This function can be used e.g. in fan and pump applications 0 = Disabled 1 = Enabled
P3.1.2.13	Stator voltage adjust	50.0	150.0	%	100.0	659	Parameter for adjusting the stator voltage in permanent magnet motors.



3.4.14.3 Limits

Table 39. Motor limit settings

Code	Parameter	Min	Max	Unit	Default	ID	Description
P3.1.3.1	Motor current limit	Varies	Varies	A	Varies	107	Maximum motor current from AC drive
P3.1.3.2	Motor torque limit	0.0	300.0	%	300.0	1287	Maximum motoring side torque limit
P3.1.3.3	Generator torque limit	0.0	300.0	%	300.0	1288	Maximum generating side torque limit
P3.1.3.4	Motor power limit	0.0	300.0	%	300.0	1290	Maximum motoring side power limit
P3.1.3.5	Generator power limit	0.0	300.0	%	300.0	1289	Maximum generating side power limit

3.4.14.4 Open loop settings

Table 40. Open loop settings

Code	Parameter	Min	Max	Unit	Default	ID	Description
P3.1.4.1	U/f ratio	0	2		0	108	Type of U/f curve between zero frequency and the field weakening point. 0=Linear 1=Squared 2=Programmable
P3.1.4.2	Field weakening point frequency	8.00	P3.3.1.2	Hz	Varies	602	The field weakening point is the output frequency at which the output voltage reaches the field weakening point voltage
P3.1.4.3	Voltage at field weakening point	10.00	200.00	%	100.00	603	Voltage at field weakening point in % of motor nominal voltage
P3.1.4.4	U/f midpoint frequency	0.00	P3.1.4.2	Hz	Varies	604	Provided that the programmable U/f curve has been selected (par. P3.1.4.1), this parameter defines the middle point frequency of the curve.
P3.1.4.5	U/f midpoint voltage	0.0	100.0	%	100.0	605	Provided that the programmable U/f curve has been selected (par. P3.1.4.1), this parameter defines the middle point voltage of the curve.
P3.1.4.6	Zero frequency voltage	0.00	40.00	%	Varies	606	This parameter defines the zero frequency voltage of the U/f curve. The default value varies according to unit size.



Table 40. Open loop settings

Code	Parameter	Min	Max	Unit	Default	ID	Description
P3.1.4.7	Flying start options	0	1		0	1590	Checkbox selection: B0 = Search shaft frequency from same direction as frequency reference. B1 = Disable AC scanning B4 = Use frequency reference for initial guess B5 = Disable DC pulses
P3.1.4.8	Flying start scan current	0.0	100.0	%	45.0	1610	Defined in percentage of motor nominal current.
P3.1.4.9	Auto torque boost	0	1		0	109	XXXXXXXX
P3.1.4.10	Torque boost motor gain	0.0	100.0	%	0.0	665	Scaling factor for motoring side IR-compensation when torque boost is used.
P3.1.4.11	Torque boost generator gain	0.0	100.0	%	100.0	667	Scaling factor for generating side IR-compensation when torque boost is used.
M3.1.4.12	I/f start	This menu includes three parameters. See chapter below.					

**I/f start**

The *I/f Start* function is typically used with permanent magnet motors (PM) to start the motor with constant current control. This is useful with high power motors in which the resistance is low and the tuning of the U/f curve difficult.

Applying the I/f Start function may also prove useful in providing sufficient torque for the motor at startup.

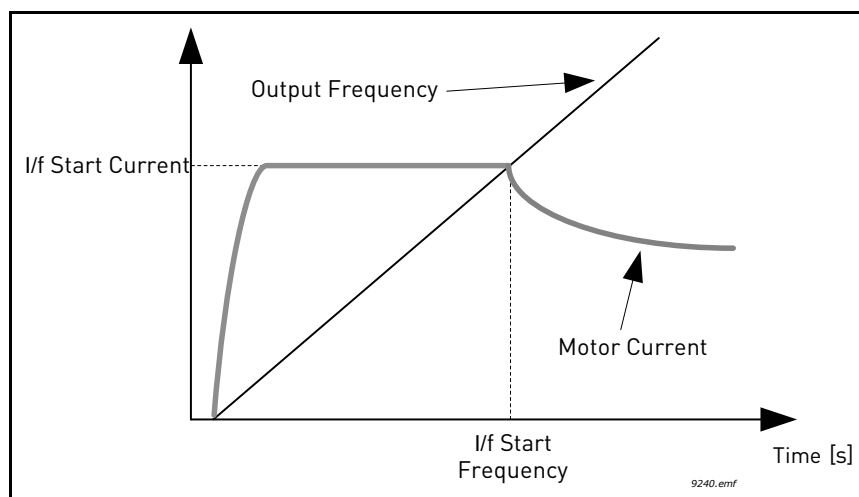

Figure 23. I/f start

Table 41. I/f start parameters

Code	Parameter	Min	Max	Unit	Default	ID	Description
P3.1.4.12.1	I/f start	0	1		0	534	0 = Disabled 1 = Enabled
P3.1.4.12.2	I/f start frequency	0.0	P3.1.1.2	%	15.0	535	Output frequency limit below which the defined I/f start current is fed to motor.
P3.1.4.12.3	I/f start current	0.0	100.0	%	80.0	536	The current fed to the motor when the I/f start function is activated.

**3.4.15 GROUP 3.2: START/STOP SETUP**

Start/Stop commands are given differently depending on the control place.

**Remote control place (I/O A):** Start, stop and reverse commands are controlled by 2 digital inputs chosen with parameters P3.5.1.1 and P3.5.1.2. The functionality/logic for these inputs is then selected with parameter P3.2.6 (in this group).

**Remote control place (I/O B):** Start, stop and reverse commands are controlled by 2 digital inputs chosen with parameters P3.5.1.4 and P3.5.1.5. The functionality/logic for these inputs is then selected with parameter P3.2.7 (in this group).

**Local control place (Keypad):** Start and stop commands come from the keypad buttons, while the direction of rotation is selected by the parameter P3.3.1.9.

**Remote control place (Fieldbus):** Start, stop and reverse commands come from fieldbus.

Table 42. Start/Stop Setup menu

Code	Parameter	Min	Max	Unit	Default	ID	Description
P3.2.1	Remote control place	0	1		0	172	Selection of remote control place (start/stop). Can be used to change back to remote control from Vacon Live e.g. in case of a broken panel. 0=I/O control 1=Fieldbus control
P3.2.2	Local/Remote	0	1		0	211	Switch between local and remote control places 0=Remote 1=Local
P3.2.3	Keypad stop button	0	1		0	114	0=Stop button always enabled (Yes) 1=Limited function of Stop button (No)
P3.2.4	Start function	0	1		0	505	0=Ramping 1=Flying start
P3.2.5	Stop function	0	1		0	506	0=Coasting 1=Ramping
P3.2.6	I/O A start/stop logic	0	4		1	300	<b>Logic = 0:</b> Ctrl sgn 1 = Forward Ctrl sgn 2 = Backward <b>Logic = 1:</b> Ctrl sgn 1 = Forward (edge) Ctrl sgn 2 = Inverted Stop Ctrl sgn 3 = Bckwrđ (edge) <b>Logic = 2:</b> Ctrl sgn 1 = Forward (edge) Ctrl sgn 2 = Bckwrđ (edge) <b>Logic = 3:</b> Ctrl sgn 1 = Start Ctrl sgn 2 = Reverse <b>Logic = 4:</b> Ctrl sgn 1 = Start (edge) Ctrl sgn 2 = Reverse
P3.2.7	I/O B start/stop logic	0	4		1	363	See above.
P3.2.8	Fieldbus start logic	0	1		0	889	0=Rising edge required 1=State

Table 42. Start/Stop Setup menu

Code	Parameter	Min	Max	Unit	Default	ID	Description
P3.2.9	Start delay	0.000	60.000	s	0.000	524	The delay between the start command and the actual start of the drive can be given with this parameter.
P3.2.10	Remote to Local function	0	2		2	181	Choose whether to copy the Run state and Reference when changing from Remote to Local (keypad) control: 0 = Keep Run 1 = Keep Run & Reference 2 = Stop

**3.4.16 GROUP 3.3: REFERENCES**

**3.4.16.1 Frequency reference**

The frequency reference source is programmable for all control places except *PC*, which always takes the reference from the PC tool.

**Remote control place (I/O A):** The source of frequency reference can be selected with parameter P3.3.1.5.

**Remote control place (I/O B):** The source of frequency reference can be selected with parameter P3.3.1.6.

**Local control place (Keypad):** If the default selection for parameter P3.3.1.7 is used the reference set with parameter P3.3.1.8 applies.

**Remote control place (Fieldbus):** The frequency reference comes from fieldbus if the default value for parameter P3.3.1.10 is kept.

*Table 43. Frequency reference parameters*

Code	Parameter	Min	Max	Unit	Default	ID	Description
P3.3.1.1	Minimum frequency reference	0.00	P3.3.1.2	Hz	0.00	101	Minimum allowed frequency reference
P3.3.1.2	Maximum frequency reference	P3.3.1.1	320.00	Hz	50.00	102	Maximum allowed frequency reference
P3.3.1.3	Positive frequency reference limit	-320.0	320.0	Hz	320.00	1285	Final frequency reference limit for positive direction.
P3.3.1.4	Negative frequency reference limit	-320.0	320.0	Hz	-320.00	1286	Final frequency reference limit for negative direction. <b>NOTE:</b> This parameter can be used e.g. to prevent motor from running in reverse direction.
P3.3.1.5	I/O control reference A selection	0	9		5	117	Selection of ref source when control place is I/O A 0 = Preset Frequency 0 1 = Keypad reference 2 = Fieldbus 3 = AI1 4 = AI2 5 = AI1+AI2 6 = PID 1 reference 7 = Motor potentiometer 8 = Joystick reference 9 = Jogging reference
P3.3.1.6	I/O control reference B selection	0	9		3	131	Selection of ref source when control place is I/O B. See above. <b>NOTE:</b> I/O B control place can only be forced active with digital input (P3.5.1.7).

Table 43. Frequency reference parameters

Code	Parameter	Min	Max	Unit	Default	ID	Description
P3.3.1.7	Keypad Ctrl Reference selection	0	9		1	121	Selection of ref source when control place is keypad: 0 = Preset Frequency 0 1 = Keypad 2 = Fieldbus 3 = AI1 4 = AI2 5 = AI1+AI2 6 = PID 1 reference 7 = Motor potentiometer 8 = Joystick 9 = Jogging reference
P3.3.1.8	Keypad reference	0.00	P3.3.1.2	Hz	0.00	184	The frequency reference can be adjusted on the keypad with this parameter.
P3.3.1.9	Keypad direction	0	1		0	123	Motor rotation when control place is keypad 0 = Forward 1 = Reverse
P3.3.1.10	Fieldbus control reference selection	0	9		2	122	Selection of ref source when control place is Fieldbus: 0 = Preset frequency 0 1 = Keypad 2 = Fieldbus 3 = AI1 4 = AI2 5 = AI1+AI2 6 = PID 1 reference 7 = Motor potentiometer 8 = Joystick 9 = Jogging reference

3.4.16.2 Torque reference

When parameter P3.1.2.1 [Control mode] is set to '2/OL' *Torque Control*, the drive's speed reference is used as the maximum speed limit and the motor produces torque within the speed limit to achieve the torque reference.

In Torque control mode, the motor speed is limited to the drive's maximum output frequency (P3.3.1.2).

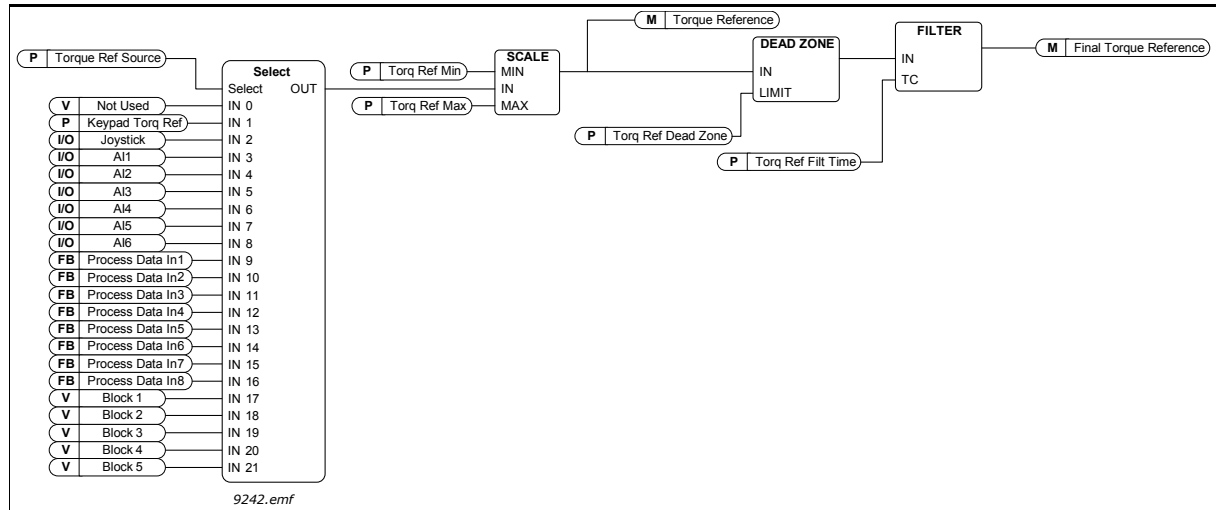

Figure 24. Torque reference chain

Table 44. Torque reference parameters

Code	Parameter	Min	Max	Unit	Default	ID	Description
P3.3.2.1	Torque reference selection	0	21		0	641	Selection of torque reference. The torque reference is scaled between the values of P3.3.2.2 and P3.3.2.3. 0 = Not used 1 = Keypad 2 = Joystick 3 = AI1 4 = AI2 5 = AI3 6 = AI4 7 = AI5 8 = AI6 9 = ProcessDataIn 1 10 = ProcessDataIn 2 11 = ProcessDataIn 3 12 = ProcessDataIn 4 13 = ProcessDataIn 5 14 = ProcessDataIn 6 15 = ProcessDataIn 7 16 = ProcessDataIn 8 17=Block 1 Out 18=Block 2 Out 19=Block 3 Out 20=Block 4 Out 21=Block 5 Out <b>NOTE!</b> If you are using any fieldbus protocol where the torque reference can be given in [Nm] -units, option ProcessDataIn1 must be selected to this parameter.

Table 44. Torque reference parameters

Code	Parameter	Min	Max	Unit	Default	ID	Description
P3.3.2.2	Torque minimum reference	-300.0	300.0	%	0.0	643	Torque reference corresponding the minimum value of reference signal.
P3.3.2.3	Torque maximum reference	-300.0	300.0	%	100.0	642	Torque reference corresponding the maximum value of reference signal. <b>NOTE!</b> Used as maximum allowed torque reference for negative and positive values.
P3.3.2.4	Torque reference filter time	0.00	300.00	s	0.00	1244	Defines the filtering time for the final torque reference.
P3.3.2.5	Torque reference dead zone	0.0	300.0	%	0.0	1246	Small values of the torque reference around zero can be ignored by setting this value greater than zero. When the torque reference is between zero to plus/minus this parameter, the reference is forced to zero.
P3.3.2.6	Keypad torque reference	0.0	100.0	%	0.0	1439	Used when P3.3.2.1 is set to '1'. The value of this parameter is limited between P3.3.2.3 and P3.3.2.2.
M3.3.2.7	Torque control Open Loop	This menu includes three parameters, see table below.					

**Torque control Open Loop**













Table 45. Torque control Open Loop parameters

Code	Parameter	Min	Max	Unit	Default	ID	Description
P3.3.2.7.1	Open Loop torque control minimum frequency	0.0	P3.3.1.2	Hz	3.0	636	Output frequency limit below which the drive operates in frequency control mode.
P3.3.2.7.2	Open Loop torque control P gain	0.0	32000.0		0.01	639	Defines the P gain for the torque controller in open loop control mode. P-Gain value 1.0 causes a 1-Hz change in the output frequency when the torque error is 1% of the motor nominal torque.
P3.3.2.7.3	Open Loop torque control I gain	0.0	32000.0		2.0	640	Defines the I gain for the torque controller in open loop control mode. I-Gain value 1.0 causes the integration to reach 1.0 Hz in 1 second when the torque error is 1% of the motor nominal torque.



3.4.16.3 Preset frequencies

Table 46. Preset frequencies parameters

Code	Parameter	Min	Max	Unit	Default	ID	Description
 P3.3.3.1	Preset frequency mode	0	1		0	182	0 = Binary coded 1 = Number of inputs. Preset frequency is selected according to how many of preset speed digital inputs are active
 P3.3.3.2	Preset frequency 0	P3.3.1.1	P3.3.1.2	Hz	5.00	180	Basic preset frequency 0 when selected by Control reference parameter (P3.3.1.5).
 P3.3.3.3	Preset frequency 1	P3.3.1.1	P3.3.1.2	Hz	10.00	105	Select with digital input: Preset frequency selection 0 (P3.3.3.10)
 P3.3.3.4	Preset frequency 2	P3.3.1.1	P3.3.1.2	Hz	15.00	106	Select with digital input: Preset frequency selection 1 (P3.3.3.11)
 P3.3.3.5	Preset frequency 3	P3.3.1.1	P3.3.1.2	Hz	20.00	126	Select with digital inputs: Preset frequency selection 0 & 1
 P3.3.3.6	Preset frequency 4	P3.3.1.1	P3.3.1.2	Hz	25.00	127	Select with digital input: Preset frequency selection 2 (P3.3.3.12)
 P3.3.3.7	Preset frequency 5	P3.3.1.1	P3.3.1.2	Hz	30.00	128	Select with digital inputs: Preset frequency selection 0 & 2
 P3.3.3.8	Preset frequency 6	P3.3.1.1	P3.3.1.2	Hz	40.00	129	Select with digital inputs: Preset frequency selection 1 & 2
 P3.3.3.9	Preset frequency 7	P3.3.1.1	P3.3.1.2	Hz	50.00	130	Select with digital inputs: Preset frequency selection 0 & 1 & 2
 P3.3.3.10	Preset frequency selection 0				DigIN SlotA.4	419	Binary selector for Preset speeds (0-7). See parameters P3.3.3.2 to P3.3.3.9.
 P3.3.3.11	Preset frequency selection 1				DigIN SlotA.5	420	Binary selector for Preset speeds (0-7). See parameters P3.3.3.2 to P3.3.3.9.
 P3.3.3.12	Preset frequency selection 2				DigIN Slot0.1	421	Binary selector for Preset speeds (0-7). See parameters P3.3.3.2 to P3.3.3.9.

3.4.16.4 Motor potentiometer parameters

With a motor potentiometer function, the user can increase and decrease the output frequency. By connecting a digital input to parameter P3.3.4.1 (*Motor potentiometer UP*) and having the digital input signal active, the output frequency will rise as long as the signal is active. The parameter P3.3.4.2 (*Motor potentiometer DOWN*) works vice versa, decreasing the output frequency.

The rate how the output frequency either rises or falls when Motor Potentiometer Up or Down is activated is determined by the *Motor potentiometer ramp time* (P3.3.4.3)

The Motor potentiometer reset parameter (P3.3.4.4) is used to choose whether to reset (set to MinFreq) the Motor Potentiometer frequency reference when stopped or when powered down.

Motor potentiometer frequency reference is available in all control places in menu Group 3.3: References. The motor potentiometer reference can be changed only when the drive is in run state.



Table 47. Motor potentiometer parameters

Code	Parameter	Min	Max	Unit	Default	ID	Description
P3.3.4.1	Motor potentiometer UP				DigIN Slot0.1	418	FALSE = Not active TRUE = Active (Motor potentiometer reference INCREASES until the contact is opened)
P3.3.4.2	Motor potentiometer DOWN				DigIN Slot0.1	417	FALSE = Not active TRUE = Active (Motor potentiometer reference DECREASES until the contact is opened)
P3.3.4.3	Motor potentiometer ramp time	0.1	500.0	Hz/s	10.0	331	Rate of change in the motor potentiometer reference when increased or decreased with parameters P3.3.4.1 or P3.3.4.2.
P3.3.4.4	Motor potentiometer reset	0	2		1	367	Motor potentiometer frequency reference reset logic. 0 = No reset 1 = Reset if stopped 2 = Reset if powered down

3.4.16.5 Joystick control parameters

The Joystick function is, as its name implies, used when the forward and reverse rotation of the drive is linearly controlled in both directions by a joystick. Motor control through a joystick is possible by connecting the joystick signal to one of the analogue inputs and setting the other joystick parameters.

Table 48. Joystick control parameters

Code	Parameter	Min	Max	Unit	Default	ID	Description
 P3.3.5.1	Joystick signal selection	0	6		0	451	0=Not Used 1=AI1 (0-100%) 2=AI2 (0-100%) 3=AI3 (0-100%) 4=AI4 (0-100%) 5=AI5 (0-100%) 6=AI6 (0-100%)
 P3.3.5.2	Joystick dead zone	0.0	20.0	%	2.0	384	When reference is between zero to zero plus/minus this parameter reference is forced to zero.
 P3.3.5.3	Joystick sleep delay	0.00	300.00	s	0.00	386	The AC drive is stopped if the joystick signal has been in the dead zone defined by P3.3.5.2 for the amount of time set with this parameter.

3.4.16.6 Jogging parameters

The Jogging function is used for momentary overriding of normal control. This function can be used e.g. for controlling the process slowly to a certain state or position during maintenance work without a need to change the drive’s control place or other parameterization.

Jogging function can be activated only when the drive is in stop state. The Jogging function will start the drive at selected reference without additional start command regardless of the control place. Two bi-directional frequency references can be used. Jogging function can be activated either from the fieldbus or by digital input signals. Jogging function has its own ramp time which will be used always when jogging is active.

Jogging can be activated from Fieldbus in bypass mode by Control Word bits 10 and 11.

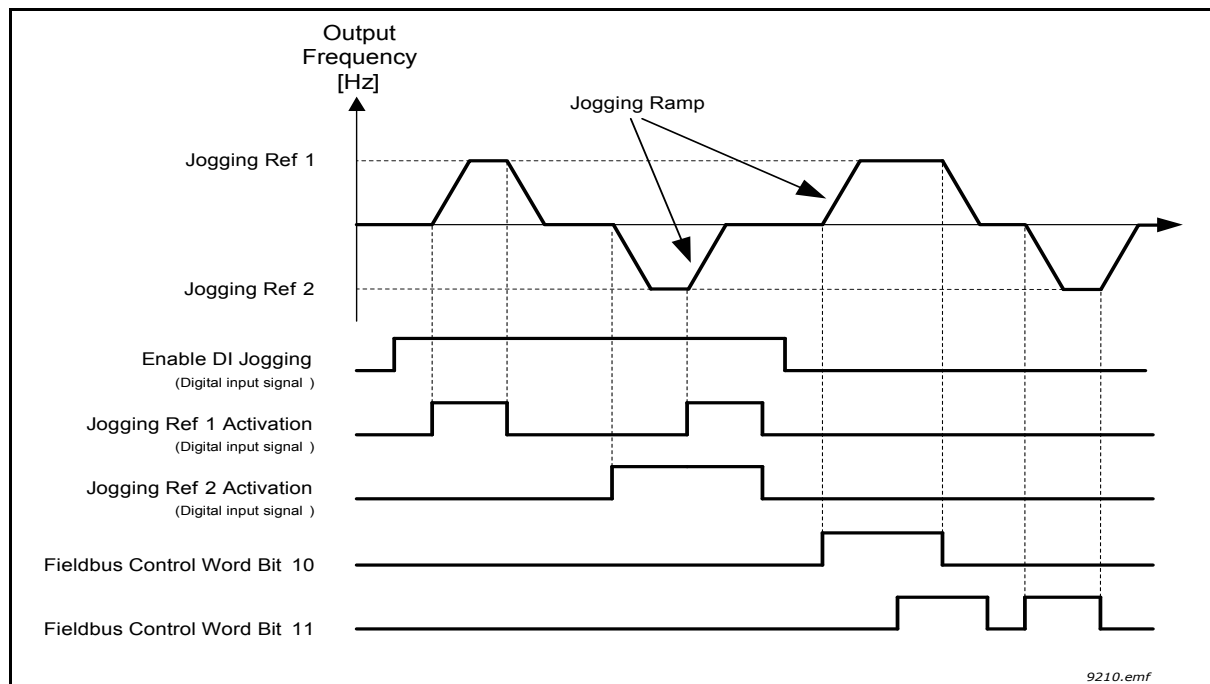

Figure 25. Jogging parameters

Table 49. Jogging parameters

Code	Parameter	Min	Max	Unit	Default	ID	Description
P3.3.6.1	Enable DI jogging	Varies	Varies		DigIN Slot0.1	532	Enables jogging function from digital inputs. Does not affect jogging from fieldbus. <b>NOTE:</b> Jogging can be enabled only when the drive is in stop state.
P3.3.6.2	Activate jogging reference 1	Varies	Varies		DigIN Slot0.1	530	Connect to digital input to activate par. P3.3.6.4. <b>NOTE:</b> The drive will start if the input is activated!
P3.3.6.3	Activate jogging reference 2	Varies	Varies		DigIN Slot0.1	531	Connect to digital input to activate par. P3.3.6.5. <b>NOTE:</b> The drive will start if the input is activated!
P3.3.6.4	Jogging reference 1	-MaxRef	MaxRef	Hz	0.00	1239	Defines the frequency reference when jogging reference 1 is activated (P3.3.6.2).
P3.3.6.5	Jogging reference 2	-MaxRef	MaxRef	Hz	0.00	1240	Defines the frequency reference when jogging reference 2 is activated (P3.3.6.3).
P3.3.6.6	Jogging ramp	0.1	300.0	s	10.0	1257	This parameter defines the acceleration and deceleration times when jogging is active.

**3.4.17 GROUP 3.4: RAMPS & BRAKES SETUP**

**3.4.17.1 Ramp 1**

*Table 50. Ramp 1 setup*

Code	Parameter	Min	Max	Unit	Default	ID	Description
P3.4.1.1	Ramp 1 shape	0.0	100.0	%	0.0	500	The start and the end of acceleration and deceleration ramps can be smoothed with this parameter.
P3.4.1.2	Acceleration time 1	0.1	300.0	s	5.0	103	Defines the time required for the output frequency to increase from zero frequency to maximum frequency
P3.4.1.3	Deceleration time 1	0.1	300.0	s	5.0	104	Defines the time required for the output frequency to decrease from maximum frequency to zero frequency

**3.4.17.2 Ramp 2**

*Table 51. Ramp 2 setup*

Code	Parameter	Min	Max	Unit	Default	ID	Description
P3.4.2.1	Ramp 2 shape	0.0	100.0	%	0.0	501	The start and the end of acceleration and deceleration ramps can be smoothed with this parameter.
P3.4.2.2	Acceleration time 2	0.1	300.0	s	10.0	502	Defines the time required for the output frequency to increase from zero frequency to maximum frequency
P3.4.2.3	Deceleration time 2	0.1	300.0	s	10.0	503	Defines the time required for the output frequency to decrease from maximum frequency to zero frequency
P3.4.2.4	Ramp 2 selection	Varies	Varies		DigIN Slot0.1	408	Used for switching between ramps 1 and 2. FALSE = Ramp 1 shape, acceleration time 1 and deceleration time 1. TRUE = Ramp 2 shape, acceleration time 2 and Deceleration time 2.

3.4.17.3 Start magnetization

Table 52. Start magnetization parameters

Code	Parameter	Min	Max	Unit	Default	ID	Description
P3.4.3.1	Start magnetizing current	0.00	Varies	A	Varies	517	Defines the DC current fed into motor at start. Disabled if set to 0.
P3.4.3.2	Start magnetizing time	0,00	600,00	s	0,00	516	This parameter defines the time for how long DC current is fed to motor before acceleration starts.

3.4.17.4 DC brake

Table 53. DC-brake parameters

Code	Parameter	Min	Max	Unit	Default	ID	Description
P3.4.4.1	DC brake current	Varies	Varies	A	Varies	507	Defines the current injected into the motor during DC-braking. 0 = Disabled
P3.4.4.2	DC braking time at stop	0,00	600,00	s	0,00	508	Determines if braking is ON or OFF and the braking time of the DC-brake when the motor is stopping.
P3.4.4.3	Frequency to start DC braking at ramp stop	0,10	10,00	Hz	1,50	515	The output frequency at which the DC-braking is applied.

3.4.17.5 Flux braking

Table 54. Flux braking parameters

Code	Parameter	Min	Max	Unit	Default	ID	Description
P3.4.5.1	Flux braking	0	1		0	520	0=Disabled 1=Enabled
P3.4.5.2	Flux braking current	0	Varies	A	Varies	519	Defines the current level for flux braking.

### 3.4.18 GROUP 3.5: I/O CONFIGURATION

#### 3.4.18.1 Default assignments of programmable inputs

Table 55 below presents the default assignments of programmable digital and analogue inputs in Vacon 100 General-Purpose application.

Table 55. Default assignments of inputs

Input	Terminal(s)	Reference	Assigned function	Parameter code
D11	8	A.1	Control signal 1 A	P3.5.1.1
D12	9	A.2	Control signal 2 A	P3.5.1.2
D13	10	A.3	External fault close	P3.5.1.11
D14	14	A.4	Preset frequency selection 0	P3.5.1.21
D15	15	A.5	Preset frequency selection 1	P3.5.1.22
D16	16	A.6	External fault close	P3.5.1.13
A11	2/3	A.1	A11 signal selection	P3.5.2.1.1
A12	4/5	A.2	A12 signal selection	P3.5.2.2.1

#### 3.4.18.2 Digital inputs

Digital inputs are very flexible to use. Parameters are functions that are connected to the required digital input terminal (see chapter 3.4.13). The digital inputs are represented as, for example, *DigIN Slot A.2*, meaning the second input on slot A.

It is also possible to connect the digital inputs to time channels which are also represented as terminals.

**NOTE!** The statuses of digital inputs and the digital output can be monitored in the Multimonitoring view, see chapter 3.4.1.

Table 56. Digital input settings

Code	Parameter	Default	ID	Description
P3.5.1.1	Control signal 1 A	DigIN SlotA.1	403	Ctrl signal 1 when control place is I/O A (FWD)
P3.5.1.2	Control signal 2 A	DigIN SlotA.2	404	Ctrl signal 2 when control place is I/O A (REV)
P3.5.1.3	Control signal 3 A	DigIN Slot0.1	434	Ctrl signal 3 when control place is I/O A
P3.5.1.4	Control signal 1 B	DigIN Slot0.1	423	Start signal 1 when control place is I/O B
P3.5.1.5	Control signal 2 B	DigIN Slot0.1	424	Start signal 2 when control place is I/O B
P3.5.1.6	Control signal 3 B	DigIN Slot0.1	435	Start signal 3 when control place is I/O B
P3.5.1.7	I/O B control force	DigIN Slot0.1	425	TRUE = Force the control place to I/O B
P3.5.1.8	I/O B reference force	DigIN Slot0.1	343	TRUE = Used frequency reference is specified by I/O reference B parameter (P3.3.1.6).
P3.5.1.9	Fieldbus control force	DigIN Slot0.1	411	Force control to fieldbus
P3.5.1.10	Keypad control force	DigIN Slot0.1	410	Force control to keypad
P3.5.1.11	External fault close	DigIN SlotA.3	405	FALSE = OK TRUE = External fault
P3.5.1.12	External fault open	DigIN Slot0.2	406	FALSE = External fault TRUE = OK



Table 56. Digital input settings

Code	Parameter	Default	ID	Description
P3.5.1.13	Fault reset close	DigIN SlotA.6	414	Resets all active faults when TRUE
P3.5.1.14	Fault reset open	DigIN Slot0.1	213	Resets all active faults when FALSE
P3.5.1.15	Run enable	DigIN Slot0.2	407	Must be on to set drive in Ready state
P3.5.1.16	Run interlock 1	DigIN Slot0.2	1041	Drive may be ready but start is blocked as long as interlock is on (Damper interlock).
P3.5.1.17	Run interlock 2	DigIN Slot0.2	1042	As above.
P3.5.1.18	Motor preheat ON	DigIN Slot0.1	1044	FALSE = No action TRUE = Uses the motor preheat DC-Current in Stop state. Used when parameter P3.18.1 is set to 2.
P3.5.1.19	Ramp 2 selection	DigIN Slot0.1	408	Used for switching between ramps 1 and 2. FALSE = Ramp 1 shape, acceleration time 1 and deceleration time 1. TRUE = Ramp 2 shape, acceleration time 2 and Deceleration time 2.
P3.5.1.20	Acc/Dec prohibit	DigIN Slot0.1	415	No acceleration or deceleration possible until the contact is opened.
P3.5.1.21	Preset frequency selection 0	DigIN SlotA.4	419	Binary selector for Preset speeds (0-7). See page 70.
P3.5.1.22	Preset frequency selection 1	DigIN SlotA.5	420	Binary selector for Preset speeds (0-7). See page 70.
P3.5.1.23	Preset frequency selection 2	DigIN Slot0.1	421	Binary selector for Preset speeds (0-7). See page 70.
P3.5.1.24	Motor potentiometer UP	DigIN Slot0.1	418	FALSE = Not active TRUE = Active (Motor potentiometer reference INCREASES until the contact is opened)
P3.5.1.25	Motor potentiometer DOWN	DigIN Slot0.1	417	FALSE = Not active TRUE = Active (Motor potentiometer reference DECREASES until the contact is opened)
P3.5.1.26	Quick stop activation	DigIN Slot0.2	1213	FALSE = Activated. See parameter group Quick Stop (page 93) in order to configure these functions.
P3.5.1.27	Timer 1	DigIN Slot0.1	447	Rising edge starts Timer 1 programmed in Group 3.12: Timer functions parameter group
P3.5.1.28	Timer 2	DigIN Slot0.1	448	See above
P3.5.1.29	Timer 3	DigIN Slot0.1	449	See above
P3.5.1.30	PID1 setpoint boost	DigIN Slot0.1	1046	FALSE = No boost TRUE = Boost
P3.5.1.31	PID1 select setpoint	DigIN Slot0.1	1047	FALSE = Setpoint 1 TRUE = Setpoint 2
P3.5.1.32	External PID start signal	DigIN Slot0.2	1049	FALSE = PID2 in stop mode TRUE = PID2 regulating This parameter will have no effect if the external PID-controller is not enabled in Group 3.14: External PID-controller.
P3.5.1.33	External PID select setpoint	DigIN Slot0.1	1048	FALSE = Setpoint 1 TRUE = Setpoint 2
P3.5.1.34	Motor 1 interlock	DigIN Slot0.1	426	FALSE = Not active TRUE = Active
P3.5.1.35	Motor 2 interlock	DigIN Slot0.1	427	FALSE = Not active TRUE = Active

Table 56. Digital input settings

Code	Parameter	Default	ID	Description
P3.5.1.36	Motor 3 interlock	DigIN Slot0.1	428	FALSE = Not active TRUE = Active
P3.5.1.37	Motor 4 interlock	DigIN Slot0.1	429	FALSE = Not active TRUE = Active
P3.5.1.38	Motor 5 interlock	DigIN Slot0.1	430	FALSE = Not active TRUE = Active
P3.5.1.39	Motor 6 interlock	DigIN Slot0.1	486	FALSE = Not active TRUE = Active
P3.5.1.40	Reset maintenance counter	DigIN Slot0.1	490	TRUE = Reset
P3.5.1.41	Enable DI jogging	DigIN Slot0.1	532	Enables jogging function from digital inputs. Does not affect jogging from fieldbus.
P3.5.1.42	Jogging reference 1 activation	DigIN Slot0.1	530	Connect to digital input to activate par. P3.3.6.4. <b>NOTE:</b> The drive will start if the input is activated!
P3.5.1.43	Jogging reference 2 activation	DigIN Slot0.1	531	Connect to digital input to activate par. P3.3.6.5. <b>NOTE:</b> The drive will start if the input is activated!
P3.5.1.44	Mechanical brake feedback	DigIN Slot0.1	1210	Connect this input signal to the auxiliary contact of the mechanical brake. If the contact is not closed within given time the drive will generate a brake fault. See page 120.
P3.5.1.45	Fire mode activation OPEN	DigIN Slot0.2	1596	Activates the Fire Mode if enabled by correct password. FALSE = Fire Mode active TRUE = No action
P3.5.1.46	Fire mode activation CLOSE	DigIN Slot0.1	1619	Activates the Fire Mode if enabled by correct password. FALSE = No action TRUE = Fire Mode active
P3.5.1.47	Fire mode reverse	DigIN Slot0.1	1618	Reverse command of rotation direction while running in Fire Mode. This function has no effect in normal operation. FALSE = Forward TRUE = Reverse
P3.5.1.48	Auto-cleaning activation	DigIN Slot0.1	1715	Start the Auto-cleaning sequence. The sequence will be aborted if activation signal is removed before the sequence has been completed. <b>NOTE!</b> The drive will start if the input is activated!

3.4.18.3 Analogue inputs

**NOTE!** The number of usable analogue inputs depends on your (option) board setup. The standard I/O board embodies 2 analogue inputs.

**Analogue input 1**

Table 57. Analogue input 1 settings

Code	Parameter	Min	Max	Unit	Default	ID	Description
P3.5.2.1.1	AI1 signal selection				AnIN SlotA.1	377	Connect the AI1 signal to the analogue input of your choice with this parameter. Programmable. See page 51.
P3.5.2.1.2	AI1 signal filter time	0.00	300.00	s	0.1	378	Filter time for analogue input.
P3.5.2.1.3	AI1 signal range	0	1		0	379	0 = 0...10V / 0...20mA 1 = 2...10V / 4...20mA
P3.5.2.1.4	AI1 custom. min	-160.00	160.00	%	0.00	380	Custom range min setting 20% = 4-20 mA/2-10 V
P3.5.2.1.5	AI1 custom. max	-160.00	160.00	%	100.00	381	Custom range max setting
P3.5.2.1.6	AI1 signal inversion	0	1		0	387	0 = Normal 1 = Signal inverted

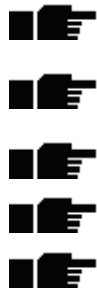

**Analogue input 2**

Table 58. Analogue input 2 settings

Code	Parameter	Min	Max	Unit	Default	ID	Description
P3.5.2.2.1	AI2 signal selection				AnIN SlotA.2	388	See P3.5.2.1.1.
P3.5.2.2.2	AI2 signal filter time	0.00	300.00	s	0.1	389	See P3.5.2.1.2.
P3.5.2.2.3	AI2 signal range	0	1		1	390	See P3.5.2.1.3
P3.5.2.2.4	AI2 custom. min	-160.00	160.00	%	0.00	391	See P3.5.2.1.4.
P3.5.2.2.5	AI2 custom. max	-160.00	160.00	%	100.00	392	See P3.5.2.1.5.
P3.5.2.2.6	AI2 signal inversion	0	1		0	398	See P3.5.2.1.6.

**Analogue input 3**

Table 59. Analogue input 3 settings

Code	Parameter	Min	Max	Unit	Default	ID	Description
P3.5.2.3.1	AI3 signal selection				AnIN SlotD.1	141	See P3.5.2.1.1.
P3.5.2.3.2	AI3 signal filter time	0.00	300.00	s	0.1	142	See P3.5.2.1.2.
P3.5.2.3.3	AI3 signal range	0	1		0	143	See P3.5.2.1.3
P3.5.2.3.4	AI3 custom. min	-160.00	160.00	%	0.00	144	See P3.5.2.1.4.
P3.5.2.3.5	AI3 custom. max	-160.00	160.00	%	100.00	145	See P3.5.2.1.5.
P3.5.2.3.6	AI3 signal inversion	0	1		0	151	See P3.5.2.1.6.

**Analogue input 4***Table 60. Analogue input 4 settings*

Code	Parameter	Min	Max	Unit	Default	ID	Description
P3.5.2.4.1	AI4 signal selection				AnIN SlotD.2	152	See P3.5.2.1.1.
P3.5.2.4.2	AI4 signal filter time	0.00	300.00	s	0.1	153	See P3.5.2.1.2.
P3.5.2.4.3	AI4 signal range	0	1		0	154	See P3.5.2.1.3.
P3.5.2.4.4	AI4 custom. min	-160.00	160.00	%	0.00	155	See P3.5.2.1.4.
P3.5.2.4.5	AI4 custom. max	-160.00	160.00	%	100.00	156	See P3.5.2.1.5.
P3.5.2.4.6	AI4 signal inversion	0	1		0	162	See P3.5.2.1.6.

**Analogue input 5***Table 61. Analogue input 5 settings*

Code	Parameter	Min	Max	Unit	Default	ID	Description
P3.5.2.5.1	AI5 signal selection				AnIN SlotE.1	188	See P3.5.2.1.1.
P3.5.2.5.2	AI5 signal filter time	0.00	300.00	s	0.1	189	See P3.5.2.1.2.
P3.5.2.5.3	AI5 signal range	0	1		0	190	See P3.5.2.1.3.
P3.5.2.5.4	AI5 custom. min	-160.00	160.00	%	0.00	191	See P3.5.2.1.4.
P3.5.2.5.5	AI5 custom. max	-160.00	160.00	%	100.00	192	See P3.5.2.1.5.
P3.5.2.5.6	AI5 signal inversion	0	1		0	198	See P3.5.2.1.6.

**Analogue input 6***Table 62. Analogue input 6 settings*

Code	Parameter	Min	Max	Unit	Default	ID	Description
P3.5.2.6.1	AI6 signal selection				AnIN SlotE.2	199	See P3.5.2.1.1.
P3.5.2.6.2	AI6 signal filter time	0.00	300.00	s	0.1	200	See P3.5.2.1.2.
P3.5.2.6.3	AI6 signal range	0	1		0	201	See P3.5.2.1.3.
P3.5.2.6.4	AI6 custom. min	-160.00	160.00	%	0.00	202	See P3.5.2.1.4.
P3.5.2.6.5	AI6 custom. max	-160.00	160.00	%	100.00	203	See P3.5.2.1.5.
P3.5.2.6.6	AI6 signal inversion	0	1		0	209	See P3.5.2.1.6.

3.4.18.4 *Digital outputs, slot B (Standard)*

Table 63. Digital output settings on standard I/O board

Code	Parameter	Min	Max	Unit	Default	ID	Description
P3.5.3.2.1	Basic R01 function	0	56		2	11001	Function sel. for Basic R01: 0 = None 1 = Ready 2 = Run 3 = General fault 4 = General fault inverted 5 = General alarm 6 = Reversed 7 = At speed 8 = Thermistor fault 9 = Motor regulator active 10 = Start signal active 11 = Keypad control active 12 = I/O B control activated 13 = Limit supervision 1 14 = Limit supervision 2 15 = Fire Mode active 16 = Jogging activated 17 = Preset speed active 18 = Quick stop activated 19 = PID in Sleep mode 20 = PID soft fill active 21 = PID supervision limits 22 = Ext. PID superv. limits 23 = Input press. alarm/fault 24 = Frost prot. alarm/fault 25 = Motor 1 control 26 = Motor 2 control 27 = Motor 3 control 28 = Motor 4 control 29 = Motor 5 control 30 = Motor 6 control 31 = RTC time chnl 1 control 32 = RTC time chnl 2 control 33 = RTC time chnl 3 control 34 = FB ControlWord B13 35 = FB ControlWord B14 36 = FB ControlWord B15 37 = FB ProcessData1.B0 38 = FB ProcessData1.B1 39 = FB ProcessData1.B2 40 = Maintenance alarm 41 = Maintenance fault 42 = Mechanical brake (Open brake command) 43 = Mech. brake inverted 44 = Block 1 Out 45 = Block 2 Out 46 = Block 3 Out 47 = Block 4 Out 48 = Block 5 Out 49 = Block 6 Out 50 = Block 7 Out 51 = Block 8 Out 52 = Block 9 Out 53 = Block 10 Out 54 = Jockey pump control 55 = Priming pump control 56 = Auto-cleaning active
							M3.5.3.2.2

Table 63. Digital output settings on standard I/O board

Code	Parameter	Min	Max	Unit	Default	ID	Description
M3.5.3.2.3	Basic R01 OFF delay	0.00	320.00	s	0.00	11003	OFF delay for relay
M3.5.3.2.4	Basic R02 function	0	56		3	11004	See P3.5.3.2.1
M3.5.3.2.5	Basic R02 ON delay	0.00	320.00	s	0.00	11005	See M3.5.3.2.2.
M3.5.3.2.6	Basic R02 OFF delay	0.00	320.00	s	0.00	11006	See M3.5.3.2.3.
M3.5.3.2.7	Basic R03 function	0	56		1	11007	See P3.5.3.2.1. Not visible if only 2 output relays are installed

#### 3.4.18.5 Expander slots C, D and E digital outputs

Shows only parameters for existing outputs on option boards placed in slots C, D and E. Selections as in Standard R01 (P3.5.3.2.1).

This group or these parameters are not visible if no digital outputs exist in slots C, D or E.

3.4.18.6 Analogue outputs, Slot A (Standard)

Table 64. Standard I/O board analogue output settings

Code	Parameter	Min	Max	Unit	Default	ID	Description
P3.5.4.1.1	A01 function	0	31		2	10050	0=TEST 0% (Not used) 1=TEST 100% 2=Output freq (0 -fmax) 3=Freq reference (0-fmax) 4=Motor speed (0 - Motor nominal speed) 5=Output current (0-I <sub>nMotor</sub> ) 6=Motor torque (0-T <sub>nMotor</sub> ) 7=Motor power (0-P <sub>nMotor</sub> ) 8=Motor voltage (0-U <sub>nMotor</sub> ) 9=DC link voltage (0-1000V) 10=PID Setpoint (0-100%) 11=PID Feedback (0-100%) 12=PID1 output (0-100%) 13=Ext.PID output (0-100%) 14=ProcessDataIn1 (0-100%) 15=ProcessDataIn2 (0-100%) 16=ProcessDataIn3 (0-100%) 17=ProcessDataIn4 (0-100%) 18=ProcessDataIn5 (0-100%) 19=ProcessDataIn6 (0-100%) 20=ProcessDataIn7 (0-100%) 21=ProcessDataIn8 (0-100%) 22=Block 1 out (0-100%) 23=Block 2 out (0-100%) 24=Block 3 out (0-100%) 25=Block 4 out (0-100%) 26=Block 5 out (0-100%) 27=Block 6 out (0-100%) 28=Block 7 out (0-100%) 29=Block 8 out (0-100%) 30=Block 9 out (0-100%) 31=Block 10 out (0-100%)
P3.5.4.1.2	A01 filter time	0.0	300.0	s	1.0	10051	Filtering time of analogue output signal. See P3.5.2.1.2 0 = No filtering
P3.5.4.1.3	A01 minimum	0	1		0	10052	0 = 0 mA / 0V 1 = 4 mA / 2V Signal type (current/voltage) selected with dip switches. Note the difference in analogue output scaling in parameter P3.5.4.1.4. See also parameter P3.5.2.1.3.
P3.5.4.1.4	A01 minimum scale	Varies	Varies	Varies	0.0	10053	Min scale in process unit (depends on selection of A01 function).
P3.5.4.1.5	A01 maximum scale	Varies	Varies	Varies	0.0	10054	Max scale in process unit (depends on selection of A01 function)

### 3.4.18.7 Expander slots D to E analogue outputs

Shows only parameters for existing outputs on option boards placed in slots C, D and E. Selections as in Standard A01 (P3.5.4.1.1).

This group or these parameters are not visible if no digital outputs exist in slots C, D or E.



3.4.19 GROUP 3.6: FIELDBUS DATA MAPPING

Table 65. Fieldbus data mapping

Code	Parameter	Min	Max	Unit	Default	ID	Description
P3.6.1	Fieldbus data out 1 selection	0	35000		1	852	Data sent to fieldbus can be chosen with parameter and monitor value ID numbers. The data is scaled to unsigned 16-bit format according to the format on keypad. E.g. 25.5 on keypad equals 255.
P3.6.2	Fieldbus data out 2 selection	0	35000		2	853	Select Process Data Out with parameter ID
P3.6.3	Fieldbus data out 3 selection	0	35000		3	854	Select Process Data Out with parameter ID
P3.6.4	Fieldbus data out 4 selection	0	35000		4	855	Select Process Data Out with parameter ID
P3.6.5	Fieldbus data out 5 selection	0	35000		5	856	Select Process Data Out with parameter ID
P3.6.6	Fieldbus data out 6 selection	0	35000		6	857	Select Process Data Out with parameter ID
P3.6.7	Fieldbus data out 7 selection	0	35000		7	858	Select Process Data Out with parameter ID
P3.6.8	Fieldbus data out 8 selection	0	35000		37	859	Select Process Data Out with parameter ID

Fieldbus process data out

Default values for Process Data Out to monitor through fieldbus are listed in Table 66.

Table 66. Fieldbus Process Data Out

Data	Value	Scale
Process Data Out 1	Output frequency	0.01 Hz
Process Data Out 2	Motor speed	1 rpm
Process Data Out 3	Motor current	0.1 A
Process Data Out 4	Motor torque	0.1 %
Process Data Out 5	Motor power	0.1 %
Process Data Out 6	Motor voltage	0.1 V
Process Data Out 7	DC-link voltage	1 V
Process Data Out 8	Last active fault code	1

**Example:** Value '2500' for *Output Frequency* corresponds to '25.00 Hz' (scaling value is 0.01).

All monitoring values listed in chapter 3.4 are given the scaling value.

### 3.4.20 GROUP 3.7: PROHIBIT FREQUENCIES

In some systems it may be necessary to avoid certain frequencies due to mechanical resonance problems. By setting up prohibit frequencies it is possible to skip these ranges. When the (input) frequency reference is increased, the internal frequency reference is kept at the low limit until the (input) reference is above the high limit.

Table 67. Prohibit frequencies

Code	Parameter	Min	Max	Unit	Default	ID	Description
P3.7.1	Prohibit frequency range 1 low limit	-1,00	320,00	Hz	0,00	509	0 = Not used
P3.7.2	Prohibit frequency range 1 high limit	0,00	320,00	Hz	0,00	510	0 = Not used
P3.7.3	Prohibit frequency range 2 low limit	0,00	320,00	Hz	0,00	511	0 = Not used
P3.7.4	Prohibit frequency range 2 high limit	0,00	320,00	Hz	0,00	512	0 = Not used
P3.7.5	Prohibit frequency range 3 low limit	0,00	320,00	Hz	0,00	513	0 = Not used
P3.7.6	Prohibit frequency range 3 high limit	0,00	320,00	Hz	0,00	514	0 = Not used
P3.7.7	Ramp time factor	0,1	10,0	Times	1,0	518	Multiplier of the currently selected ramp time between prohibit frequency limits.

**3.4.21 GROUP 3.8: SUPERVISIONS**

Choose here:

1. one or two (P3.8.1/P3.8.5) signal values for supervision.
2. whether the low or high limits are supervised (P3.8.2/P3.8.6)
3. the actual limit values (P3.8.3/P3.8.7).
4. the hystereses for the set limit values (P3.8.4/P3.8.8).

*Table 68. Supervision settings*

Code	Parameter	Min	Max	Unit	Default	ID	Description
P3.8.1	Supervision #1 item selection	0	17		0	1431	0 = Output frequency 1 = Frequency reference 2 = Motor current 3 = Motor torque 4 = Motor power 5 = DC-link voltage 6 = Analogue input 1 7 = Analogue input 2 8 = Analogue input 3 9 = Analogue input 4 10 = Analogue input 5 11 = Analogue input 6 12 = Temperature input 1 13 = Temperature input 2 14 = Temperature input 3 15 = Temperature input 4 16 = Temperature input 5 17 = Temperature input 6
P3.8.2	Supervision #1 mode	0	2		0	1432	0 = Not used 1 = Low limit supervision (output active under limit) 2 = High limit supervision (output active over limit)
P3.8.3	Supervision #1 limit	-50.00	50.00	Varies	25.00	1433	Supervision limit for selected item. Unit appears automatically.
P3.8.4	Supervision #1 limit hysteresis	0.00	50.00	Varies	5.00	1434	Supervision limit hysteresis for selected item. Unit is set automatically.
P3.8.5	Supervision #2 item selection	0	17		1	1435	See P3.8.1
P3.8.6	Supervision #2 mode	0	2		0	1436	See P3.8.2
P3.8.7	Supervision #2 limit	-50.00	50.00	Varies	40.00	1437	See P3.8.3
P3.8.8	Supervision #2 limit hysteresis	0.00	50.00	Varies	5.00	1438	See P3.8.4

## 3.4.22 GROUP 3.9: PROTECTIONS

3.4.22.1 *General*

Table 69. General protections settings

Code	Parameter	Min	Max	Unit	Default	ID	Description
P3.9.1.2	Response to external fault	0	3		2	701	0 = No action 1 = Alarm 2 = Fault (Stop according to stop function) 3 = Fault (Stop by coasting)
P3.9.1.3	Response to input phase fault	0	1		0	730	0 = 3-phase support 1 = 1-phase support <b>NOTE!</b> If 1-phase supply is used, 1-phase support must be selected.
P3.9.1.4	Undervoltage fault	0	1		0	727	0 = Fault stored in history 1 = Fault not stored in history
P3.9.1.5	Response to output phase fault	0	3		2	702	See P3.9.1.2
P3.9.1.6	Response to Fieldbus communication fault	0	5		3	733	0 = No action 1 = Alarm 2 = Alarm + preset fault frequency (par. P3.9.1.12) 3 = Fault (Stop according to stop function) 4 = Fault (Stop by coasting)
P3.9.1.7	Slot communication fault	0	3		2	734	See P3.9.1.2
P3.9.1.8	Thermistor fault	0	3		0	732	See P3.9.1.2
P3.9.1.9	PID Soft Fill fault	0	3		2	748	See P3.9.1.2
P3.9.1.10	Response to PID1 supervision fault	0	3		2	749	See P3.9.1.2
P3.9.1.11	Response to external PID supervision fault	0	3		2	757	See P3.9.1.2
P3.9.1.12	Earth fault	0	3		3	703	See P3.9.1.2 <b>NOTE!</b> This fault can be configured in frames MR7 to MR9 only.
P3.9.1.13	Preset alarm frequency	P3.3.1.1	P3.3.1.2	Hz	25.00	183	This frequency used when fault response (in Group 3.9: Protections) is Alarm+preset frequency



**3.4.22.2 Motor thermal protections**

The motor thermal protection is to protect the motor from overheating. The AC drive is capable of supplying higher than nominal current to the motor. If the load requires this high current there is a risk that the motor will be thermally overloaded. This is the case especially at low frequencies. At low frequencies the cooling effect of the motor is reduced as well as its capacity. If the motor is equipped with an external fan the load reduction at low speeds is small.



The motor thermal protection is based on a calculated model and it uses the output current of the drive to determine the load on the motor.

The motor thermal protection can be adjusted with parameters, which are presented below.

The thermal stage of the motor can be monitored on the control keypad display. See chapter 3.4.

	<b>NOTE!</b> If you use long motor cables (max. 100m) together with small drives ( $\leq 1.5$ kW) the motor current measured by the drive can be much higher than the actual motor current due to capacitive currents in the motor cable. Consider this when setting up the motor thermal protection functions.
	<b>CAUTION!</b> The calculated model does not protect the motor if the airflow to the motor is reduced by blocked air intake grill. The model starts from zero if the control board is powered off.

*Table 70. Motor thermal protection settings*

Code	Parameter	Min	Max	Unit	Default	ID	Description
P3.9.2.1	Motor thermal protection	0	3		2	704	0 = No action 1 = Alarm 2 = Fault (Stop according to stop mode) 3 = Fault (Stop by coasting) If available, use the motor thermistor to protect the motor. Choose then value 0 for this parameter.
P3.9.2.2	Ambient temperature	-20.0	100.0	°C	40.0	705	Ambient temperature in °C
 P3.9.2.3	Zero speed cooling factor	5.0	150.0	%	Varies	706	Defines the cooling factor at zero speed in relation to the point where the motor is running at nominal speed without external cooling.
 P3.9.2.4	Motor thermal time constant	1	200	min	Varies	707	The time constant is the time within which the calculated thermal stage has reached 63% of its final value.
 P3.9.2.5	Motor thermal loadability	10	150	%	100	708	

3.4.22.3 Motor stall protection

The motor stall protection protects the motor from short time overload situations such as one caused by a stalled shaft. The reaction time of the stall protection can be set shorter than that of motor thermal protection. The stall state is defined with two parameters, P3.9.3.2 (*Stall current*) and P3.9.3.4 (*Stall frequency limit*). If the current is higher than the set limit and the output frequency is lower than the set limit the stall state is true. There is actually no real indication of the shaft rotation. Stall protection is a type of overcurrent protection.

	<p><b>NOTE!</b> If you use long motor cables (max. 100m) together with small drives (<math>\leq 1.5</math> kW) the motor current measured by the drive can be much higher than the actual motor current due to capacitive currents in the motor cable. Consider this when setting up the stall protection functions.</p>
-----------------------------------------------------------------------------------	--------------------------------------------------------------------------------------------------------------------------------------------------------------------------------------------------------------------------------------------------------------------------------------------------------------------------

Table 71. Motor stall protection settings

Code	Parameter	Min	Max	Unit	Default	ID	Description
P3.9.3.1	Motor stall fault	0	3		0	709	0 = No action 1 = Alarm 2 = Fault (Stop according to stop mode) 3 = Fault (Stop by coasting)
P3.9.3.2	Stall current	0.00	5.2	A	3.7	710	For a stall stage to occur, the current must have exceeded this limit.
P3.9.3.3	Stall time limit	1.00	120.00	s	15.00	711	This is the maximum time allowed for a stall stage.
P3.9.3.4	Stall frequency limit	1.00	P3.3.1.2	Hz	25.00	712	For a stall state to occur, the output frequency must have remained below this limit for a certain time.

3.4.22.4 Motor underload protection

The purpose of the motor underload protection is to ensure that there is load on the motor when the drive is running. If the motor loses its load there might be a problem in the process, e.g. a broken belt or a dry pump.

Motor underload protection can be adjusted by setting the underload curve with parameters P3.9.4.2 (*Underload protection: Field weakening area load*) and P3.9.4.3 (*Zero frequency load*). The underload curve is a squared curve set between the zero frequency and the field weakening point. The protection is not active below 5Hz (the underload time counter is stopped).

The torque values for setting the underload curve are set in percentage which refers to the nominal torque of the motor. The motor's name plate data, parameter motor nominal current and the drive's nominal current IH are used to find the scaling ratio for the internal torque value. If other than nominal motor is used with the drive, the accuracy of the torque calculation decreases.

	<p><b>NOTE!</b> If you use long motor cables (max. 100m) together with small drives (<math>\leq 1.5</math> kW) the motor current measured by the drive can be much higher than the actual motor current due to capacitive currents in the motor cable. Consider this when setting up the motor underload protection functions.</p>
-----------------------------------------------------------------------------------	------------------------------------------------------------------------------------------------------------------------------------------------------------------------------------------------------------------------------------------------------------------------------------------------------------------------------------

Table 72. Motor underload protection settings

Code	Parameter	Min	Max	Unit	Default	ID	Description
P3.9.4.1	Underload fault	0	3		0	713	0 = No action 1 = Alarm 2 = Fault (Stop according to stop mode) 3 = Fault (Stop by coasting)
P3.9.4.2	Underload protection: Field weakening area load	10.0	150.0	%	50.0	714	This parameter gives the value for the minimum torque allowed when the output frequency is above the field weakening point.
P3.9.4.3	Underload protection: Zero frequency load	5.0	150.0	%	10.0	715	This parameter gives value for the minimum torque allowed with zero frequency. If you change the value of parameter P3.1.1.4 this parameter is automatically restored to the default value.
P3.9.4.4	Underload protection: Time limit	2.00	600.00	s	20.00	716	This is the maximum time allowed for an underload state to exist.

3.4.22.5 *Quick stop*

Table 73. Quick stop settings

Code	Parameter	Min	Max	Unit	Default	ID	Description
P3.9.5.1	Quick stop mode	0	2		1	1276	Method to stop the drive if the Quick stop function is activated from DI or fieldbus 0 = Coasting 1 = Quick stop deceleration time 2 = Stop according to Stop function (P3.2.5)
P3.9.5.2	Quick stop activation	Varies	Varies		DigIN Slot0.2	1213	FALSE = Activated
P3.9.5.3	Quick stop deceleration time	0.1	300.0	s	3.0	1256	
P3.9.5.4	Response to Quick stop fault	0	2		1	744	0 = No action 1 = Alarm 2 = Fault (Stop according to Quick stop mode)



3.4.22.6 *Temperature input fault 1*

**NOTE!** This parameter group is visible only with an option board for temperature measurement (OPT-BH) installed.

Table 74. Temperature input fault 1 settings

Code	Parameter	Min	Max	Unit	Default	ID	Description
P3.9.6.1	Temperature signal 1	0	63		0	739	Selection of signals to use for alarm and fault triggering. B0 = Temperature Signal 1 B1 = Temperature Signal 2 B2 = Temperature Signal 3 B3 = Temperature Signal 4 B4 = Temperature Signal 5 B5 = Temperature Signal 6 Max value is taken of the chosen signals and used for alarm/fault triggering. <b>NOTE!</b> Only 6 first temperature inputs are supported (counting boards from slot A to slot E).
P3.9.6.2	Alarm limit 1	-30.0	200.0	°C	120.0	741	Temperature limit for triggering alarm. <b>NOTE!</b> Only inputs chosen with parameter P3.9.6.1 are compared.
P3.9.6.3	Fault limit 1	-30.0	200.0	°C	120.0	742	Temperature limit for triggering alarm. <b>NOTE!</b> Only inputs chosen with parameter P3.9.6.1 are compared.
P3.9.6.4	Fault limit response 1	0	3		2	740	0 = No response 1 = Alarm 2 = Fault (Stop according to stop mode) 3 = Fault (Stop by coasting)

3.4.22.7 Temperature input fault 2

**NOTE!** This parameter group is visible only with an option board for temperature measurement (OPTBH) installed.

Table 75. Temperature input fault 2 settings

Code	Parameter	Min	Max	Unit	Default	ID	Description
P3.9.6.5	Temperature signal 2	0	63		0	763	Selection of signals to use for alarm and fault triggering. B0 = Temperature Signal 1 B1 = Temperature Signal 2 B2 = Temperature Signal 3 B3 = Temperature Signal 4 B4 = Temperature Signal 5 B5 = Temperature Signal 6 Max value is taken of the chosen signals and used for alarm/fault triggering. <b>NOTE!</b> Only 6 first temperature inputs are supported [counting boards from slot A to slot E].
P3.9.6.6	Alarm limit 2	-30.0	200.0	°C	120.0	764	Temperature limit for triggering alarm. <b>NOTE!</b> Only inputs chosen with parameter P3.9.6.5 are compared.
P3.9.6.7	Fault limit 2	-30.0	200.0	°C	120.0	765	Temperature limit for triggering alarm. <b>NOTE!</b> Only inputs chosen with parameter P3.9.6.5 are compared.
P3.9.6.8	Fault limit response 2	0	3		2	766	0 = No response 1 = Alarm 2 = Fault (Stop according to stop mode) 3 = Fault (Stop by coasting)

3.4.22.8 AI low protection

Table 76. AI low protection settings

Code	Parameter	Min	Max	Unit	Default	ID	Description
P3.9.8.1	Analogue input low protection	0	2			767	0 = No protection 1 = Protection enabled in Run state 2 = Protection enabled in Run and Stop state
P3.9.8.2	Analogue input low fault	0	5		0	700	0=No action 1=Alarm 2=Alarm + preset fault frequency (par. P3.9.1.13) 3=Alarm + previous frequency reference 4=Fault (Stop according to stop mode) 5=Fault (Stop by coasting)

## 3.4.23 GROUP 3.10: AUTOMATIC RESET

Table 77. Autoreset settings

Code	Parameter	Min	Max	Unit	Default	ID	Description
P3.10.1	Automatic reset	0	1		0	731	0 = Disabled 1 = Enabled
P3.10.2	Restart function	0	1		1	719	The start mode for Automatic reset is selected with this parameter: 0 = Flying start 1 = According to par. P3.2.4
P3.10.3	Wait time	0.10	10000.00	s	0.50	717	Wait time before the first reset is executed.
P3.10.4	Trial time	0.00	10000.00	s	60.00	718	When the trial time has elapsed, and the fault is still active, the drive will trip to fault.
P3.10.5	Number of trials	1	10		4	759	<b>NOTE:</b> Total number of trials (irrespective of fault type). If the drive is not able to be reset within this number of trials and the set trial time a fault will be generated.
P3.10.6	Autoreset: Undervoltage	0	1		1	720	Autoreset permitted? 0 = No 1 = Yes
P3.10.7	Autoreset: Overvoltage	0	1		1	721	Autoreset permitted? 0 = No 1 = Yes
P3.10.8	Autoreset: Overcurrent	0	1		1	722	Autoreset permitted? 0 = No 1 = Yes
P3.10.9	Autoreset: AI low	0	1		1	723	Autoreset permitted? 0 = No 1 = Yes
P3.10.10	Autoreset: Unit over-temperature	0	1		1	724	Autoreset permitted? 0 = No 1 = Yes
P3.10.11	Autoreset: Motor over-temperature	0	1		1	725	Autoreset permitted? 0 = No 1 = Yes
P3.10.12	Autoreset: External fault	0	1		0	726	Autoreset permitted? 0 = No 1 = Yes
P3.10.13	Autoreset: Underload fault	0	1		0	738	Autoreset permitted? 0 = No 1 = Yes

## 3.4.24 GROUP 3.11: APPLICATION SETTINGS

Code	Parameter	Min	Max	Unit	Default	ID	Description
P3.11.1	Password	0	9999		0	1806	Administrator password
P3.11.2	C/F selection	0	1		0	1197	0 = Celsius 1 = Fahrenheit All temperature-related parameters and monitoring values are presented in the selected unit.
P3.11.3	kW/hp selection	0	1		0	1198	0 = kW 1 = hp All power-related parameters and monitoring values are presented in the selected unit
P3.11.4	Multimonitor view	0	2		1	1196	Division of keypad display into sections in Multimonitor view. 0 = 2x2 sections 1 = 3x2 sections 2 = 3x3 sections

Table 78. Application settings

**3.4.25 GROUP 3.12: TIMER FUNCTIONS**

The time functions (Time Channels) in the Vacon 100 give you the possibility to program functions to be controlled by the internal RTC (Real Time Clock). Practically every function that can be controlled by a digital input can also be controlled by a Time Channel. Instead of having an external PLC controlling a digital input you can program the "closed" and "opened" intervals of the input internally.

**NOTE!** The functions of this parameter group can be made the fullest advantage of only if the battery (option) has been installed and the Real Time Clock settings have been properly made during the Startup Wizard (see page 2 and page 3). **It is not recommended** to use these function without battery backup because the drive's time and date settings will be reset at every power down if no battery for the RTC is installed.

**Time channels**

The on/off logic for the *Time channels* is configured by assigning *Intervals* or/and *Timers* to them. One *Time channel* can be controlled by many *Intervals* or *Timers* by assigning as many of these as needed to the *Time channel*.

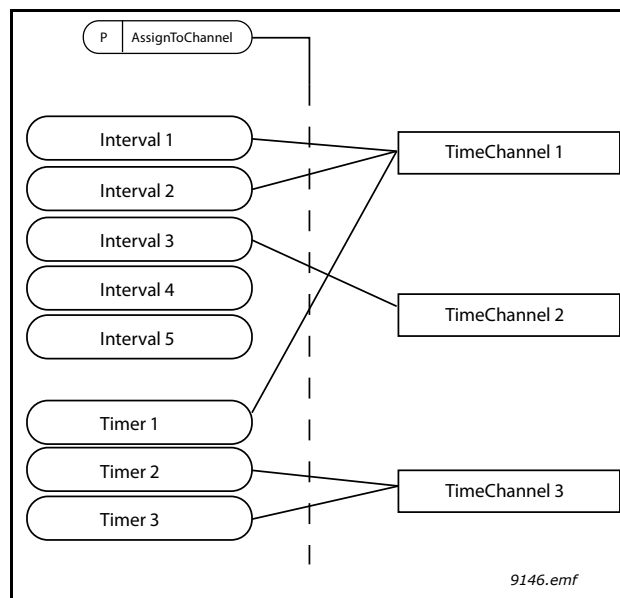

Figure 26. The intervals and timers can be assigned to time channels in a flexible way. Every interval and timer has its own parameter for assigning to a time channel.

**Intervals**

Every interval is given an "ON Time" and "OFF Time" with parameters. This is the daily time that the interval will be active during the days set with "From Day" and "To Day" parameters. E.g. the parameter setting below means that the interval is active from 7 am to 9 am every weekday (Monday to Friday). The Time Channel to which this Interval is assigned will be seen as a closed "virtual digital input" during that period.

- ON Time:** 07:00:00
- OFF Time:** 09:00:00
- From Day:** Monday
- To Day:** Friday

### Timers

Timers can be used to set a Time Channel active during a certain time by a command from a digital input (or a Time Channel).

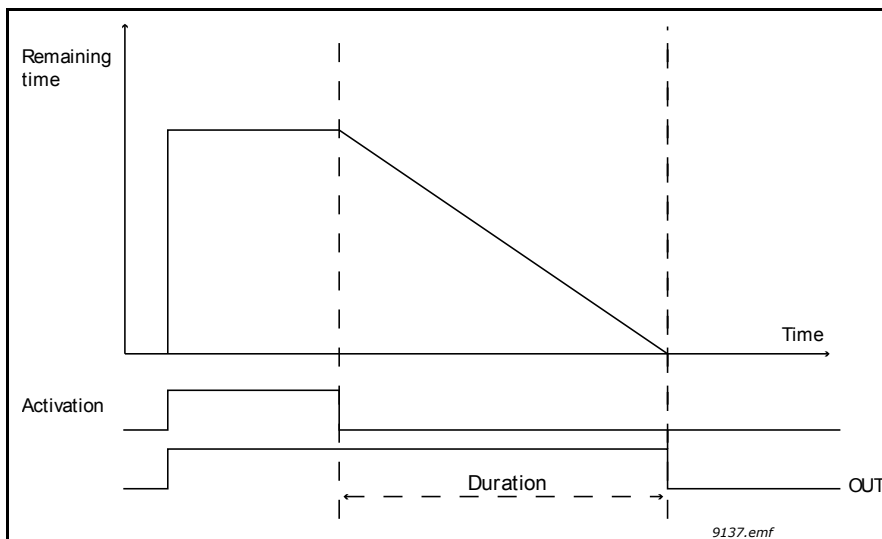

Figure 27. Activation signal comes from a digital input or " a virtual digital input" such as a Time channel. The Timer counts down from falling edge.

The below parameters will set the Timer active when Digital Input 1 on Slot A is closed and keep it active for 30s after it is opened.

**Duration:** 30s  
**Timer:** DigIn SlotA.1

**Tip:** A duration of 0 seconds can be used for simply overriding a Time channel activated from a digital input without any off delay after the falling edge.

### EXAMPLE

#### Problem:

We have an AC drive for air conditioning in a warehouse. It needs to run between 7am - 5pm on weekdays and 9am - 1pm on weekends. Additionally, we need to be able to manually force the drive to run outside working hours if there are people in the building and to leave it running for 30 min afterwards.

#### Solution:

We need to set up two intervals, one for weekdays and one for weekends. A Timer is also needed for activation outside the office hours. An example of configuration below.

#### Interval 1:

- P3.12.1.1: ON Time: **07:00:00**
- P3.12.1.2: OFF Time: **17:00:00**
- P3.12.1.3: Days: **Monday, Tuesday, Wednesday, Thursday, Friday**
- P3.12.1.4: Assign to channel: **Time channel 1**

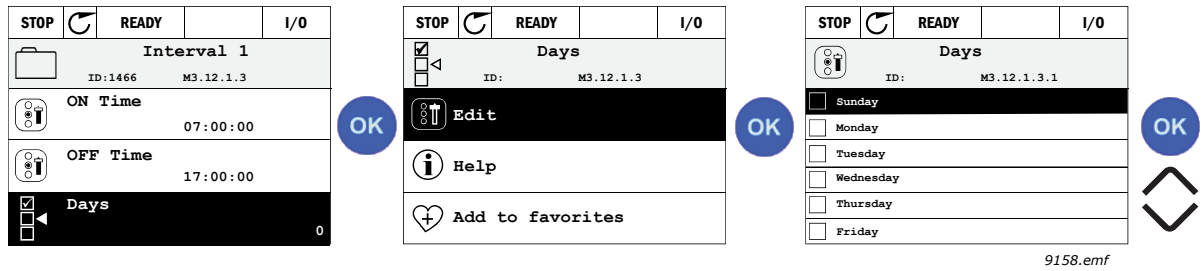

**Interval 2:**

- P3.12.2.1: *ON Time:* **09:00:00**
- P3.12.2.2: *OFF Time:* **13:00:00**
- P3.12.2.3: *Days:* **Saturday, Sunday**
- P3.12.2.4: *AssignToChannel:* **Time channel 1**

**Timer 1**

The manual bypassing can be handled by a digital input 1 on slot A (by a different switch or connection to lighting).

- P3.12.6.1: *Duration:* **1800s** (30min)
- P3.12.6.3: *Assign to channel:* **Time channel 1**

P3.12.6.2: *Timer 1: DigIn SlotA.1* (Parameter located in digital inputs menu.)

Finally select the Channel 1 for the I/O Run command.

P3.5.1.1: *Control signal 1 A:* **Time Channel 1**

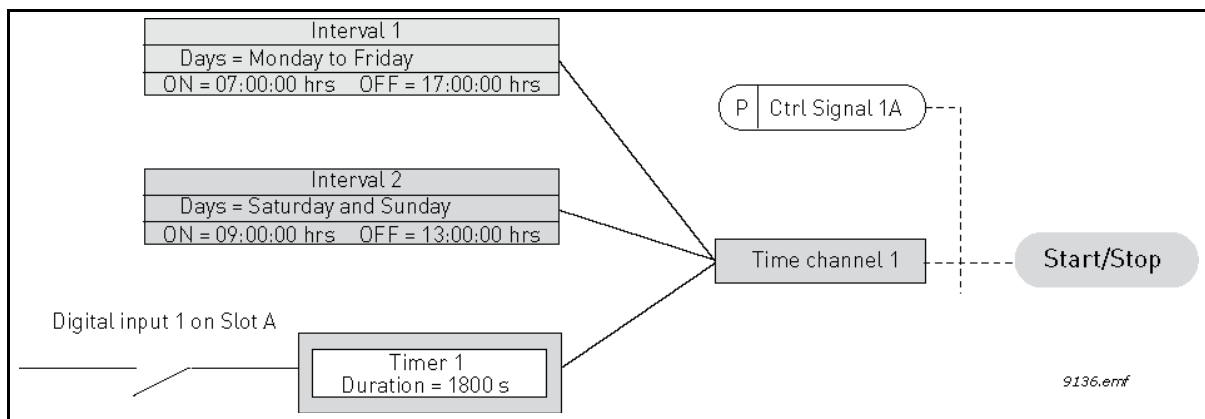

Figure 28. Final configuration where Time channel 1 is used as control signal for start command instead of a digital input.

3.4.25.1 Interval 1

Table 79. Timer functions, Interval 1

Code	Parameter	Min	Max	Unit	Default	ID	Description
P3.12.1.1	ON time	00:00:00	23:59:59	hh:mm:ss	00:00:00	1464	ON time
P3.12.1.2	OFF time	00:00:00	23:59:59	hh:mm:ss	00:00:00	1465	OFF time
P3.12.1.3	Days					1466	Days of week when active. Checkbox selection: B0 = Sunday B1 = Monday B2 = Tuesday B3 = Wednesday B4 = Thursday B5 = Friday B6 = Saturday
P3.12.1.4	Assign to channel					1468	Select affected time channel (1-3) Checkbox selection: B0 = Time channel 1 B1 = Time channel 2 B2 = Time channel 3

3.4.25.2 Interval 2

Table 80. Timer functions, Interval 2

Code	Parameter	Min	Max	Unit	Default	ID	Description
P3.12.2.1	ON time	00:00:00	23:59:59	hh:mm:ss	00:00:00	1469	See Interval 1
P3.12.2.2	OFF time	00:00:00	23:59:59	hh:mm:ss	00:00:00	1470	See Interval 1
P3.12.2.3	Days					1471	See Interval 1
P3.12.2.4	Assign to channel					1473	See Interval 1

3.4.25.3 Interval 3

Table 81. Timer functions, Interval 3

Code	Parameter	Min	Max	Unit	Default	ID	Description
P3.12.3.1	ON time	00:00:00	23:59:59	hh:mm:ss	00:00:00	1474	See Interval 1
P3.12.3.2	OFF time	00:00:00	23:59:59	hh:mm:ss	00:00:00	1475	See Interval 1
P3.12.3.3	Days					1476	See Interval 1
P3.12.3.4	Assign to channel					1478	See Interval 1



3.4.25.4 Interval 4

Table 82. Timer functions, Interval 4

Code	Parameter	Min	Max	Unit	Default	ID	Description
P3.12.4.1	ON time	00:00:00	23:59:59	hh:mm:ss	00:00:00	1479	See Interval 1
P3.12.4.2	OFF time	00:00:00	23:59:59	hh:mm:ss	00:00:00	1480	See Interval 1
P3.12.4.3	Days					1481	See Interval 1
P3.12.4.4	Assign to channel					1483	See Interval 1

3.4.25.5 Interval 5

Table 83. Timer functions, Interval 5

Code	Parameter	Min	Max	Unit	Default	ID	Description
P3.12.5.1	ON time	00:00:00	23:59:59	hh:mm:ss	00:00:00	1484	See Interval 1
P3.12.5.2	OFF time	00:00:00	23:59:59	hh:mm:ss	00:00:00	1485	See Interval 1
P3.12.5.3	Days					1486	See Interval 1
P3.12.5.4	Assign to channel					1488	See Interval 1

3.4.25.6 Timer 1

Table 84. Timer functions, Timer 1

Code	Parameter	Min	Max	Unit	Default	ID	Description
P3.12.6.1	Duration	0	72000	s	0	1489	The time the timer will run when activated. (Activated by DI)
P3.12.6.2	Timer 1				DigINSlot 0.1	447	Rising edge starts Timer 1 programmed in Group 3.12: Timer functions parameter group.
P3.12.6.3	Assign to channel					1490	Select affected time channel (1-3) Checkbox selection: B0 = Time channel 1 B1 = Time channel 2 B2 = Time channel 3

3.4.25.7 *Timer 2**Table 85. Timer functions, Timer 2*

Code	Parameter	Min	Max	Unit	Default	ID	Description
P3.12.7.1	Duration	0	72000	s	0	1491	See Timer 1
P3.12.7.2	Timer 2				DigINSlot 0.1	448	See Timer 1
P3.12.7.3	Assign to channel					1492	See Timer 1

3.4.25.8 *Timer 3**Table 86. Timer functions, Timer 3*

Code	Parameter	Min	Max	Unit	Default	ID	Description
P3.12.8.1	Duration	0	72000	s	0	1493	See Timer 1
P3.12.8.2	Timer 3				DigINSlot 0.1	448	See Timer 1
P3.12.8.3	Assign to channel					1494	See Timer 1

3.4.26 GROUP 3.13: PID-CONTROLLER 1

3.4.26.1 Basic settings

Table 87. PID controller 1 basic settings

Code	Parameter	Min	Max	Unit	Default	ID	Description
P3.13.1.1	PID gain	0.00	1000.00	%	100.00	118	If the value of the parameter is set to 100% a change of 10% in the error value causes the controller output to change by 10%.
P3.13.1.2	PID integration time	0.00	600.00	s	1.00	119	If this parameter is set to 1,00s a change of 10% in the error value causes the controller output to change by 10.00%/s.
P3.13.1.3	PID derivation time	0.00	100.00	s	0.00	132	If this parameter is set to 1,00s a change of 10% in the error value during 1.00 s causes the controller output to change by 10.00%.
P3.13.1.4	Process unit selection	1	38		1	1036	Select unit for actual value.
P3.13.1.5	Process unit min	Varies	Varies	Varies	0	1033	Value in Process units at 0% feedback or setpoint. This scaling is done for monitoring purpose only. The PID controller still uses the percentage internally for feedbacks and setpoints.
P3.13.1.6	Process unit max	Varies	Varies	Varies	100	1034	See above.
P3.13.1.7	Process unit decimals	0	4		2	1035	Number of decimals for process unit value
P3.13.1.8	Error inversion	0	1		0	340	0 = Normal (Feedback < Setpoint -> Increase PID output) 1 = Inverted (Feedback < Setpoint -> Decrease PID output)
P3.13.1.9	Dead band	Varies	Varies	Varies	0	1056	Dead band area around the setpoint in process units. The PID output is locked if the feedback stays within the deadband area for a pre-defined time.
P3.13.1.10	Dead band delay	0.00	320.00	s	0.00	1057	If the feedback stays within the dead band area for a pre-defined time, the output is locked.

3.4.26.2 Setpoints

Table 88. Setpoints settings

Code	Parameter	Min	Max	Unit	Default	ID	Description
P3.13.2.1	Keypad setpoint 1	Varies	Varies	Varies	0	167	
P3.13.2.2	Keypad setpoint 2	Varies	Varies	Varies	0	168	
P3.13.2.3	Setpoint ramp time	0.00	300.0	s	0.00	1068	Defines the rising and falling ramp times for setpoint changes. (Time to change from minimum to maximum)
P3.13.2.4	PID1 setpoint boost activation	Varies	Varies		DigIN Slot0.1	1046	FALSE = No boost TRUE = Boost
P3.13.2.5	PID1 select setpoint	Varies	Varies		DigIN Slot0.1	1047	FALSE = Setpoint 1 TRUE = Setpoint 2
P3.13.2.6	Setpoint source 1 selection	0	32		1	332	0 = Not used 1 = Keypad setpoint 1 2 = Keypad setpoint 2 3 = AI1 4 = AI2 5 = AI3 6 = AI4 7 = AI5 8 = AI6 9 = ProcessDataIn1 10 = ProcessDataIn2 11 = ProcessDataIn3 12 = ProcessDataIn4 13 = ProcessDataIn5 14 = ProcessDataIn6 15 = ProcessDataIn7 16 = ProcessDataIn8 17 = Temperature input 1 18 = Temperature input 2 19 = Temperature input 3 20 = Temperature input 4 21 = Temperature input 5 22 = Temperature input 6 23 = Block 1 Out 24 = Block 2 Out 25 = Block 3 Out 26 = Block 4 Out 27 = Block 5 Out 28 = Block 6 Out 29 = Block 7 Out 30 = Block 8 Out 31 = Block 9 Out 32 = Block 10 Out AI's and ProcessDataIn are handled as percent (0.00-100.00%) and scaled according to Setpoint minimum and maximum. <b>NOTE:</b> ProcessDataIn signals use 2 decimals. <b>NOTE:</b> If temperature inputs are selected, setpoint minimum and maximum scaling parameters needs to be set -50..200 C

Table 88. Setpoints settings

P3.13.2.5	Setpoint 1 minimum	-200.00	200.00	%	0.00	1069	Minimum value at analogue signal minimum.
P3.13.2.6	Setpoint 1 maximum	-200.00	200.00	%	100.00	1070	Maximum value at analogue signal maximum.
P3.13.2.10	Setpoint 1 boost	-2.0	2.0	x	1.0	1071	The setpoint can be boosted with a digital input.
P3.13.2.11	Setpoint source 2 selection	0	22		2	431	See par. P3.13.2.6
P3.13.2.12	Setpoint 2 minimum	-200.00	200.00	%	0.00	1073	Minimum value at analogue signal minimum.
P3.13.2.13	Setpoint 2 maximum	-200.00	200.00	%	100.00	1074	Maximum value at analogue signal maximum.
P3.13.2.17	Setpoint 2 boost	-2.0	2.0	x	1.0	1078	See P3.13.2.10.

3.4.26.3 *Feedbacks*

Table 89. Feedback settings

Code	Parameter	Min	Max	Unit	Default	ID	Description
P3.13.3.1	Feedback function	1	9		1	333	1=Only Source1 in use 2=SQRT(Source1);(Flow=Constant x SQRT(Pressure)) 3= SQRT(Source1- Source 2) 4= SQRT(Source 1) + SQRT (Source 2) 5= Source 1 + Source 2 6= Source 1 - Source 2 7=MIN (Source 1, Source 2) 8=MAX (Source 1, Source 2) 9=MEAN (Source 1, Source 2)
P3.13.3.2	Feedback function gain	-1000.0	1000.0	%	100.0	1058	Used e.g. with selection 2 in <i>Feedback function</i>
P3.13.3.3	Feedback 1 source selection	0	30		2	334	0 = Not used 1 = AI1 2 = AI2 3 = AI3 4 = AI4 5 = AI5 6 = AI6 7 = ProcessDataIn1 8 = ProcessDataIn2 9 = ProcessDataIn3 10 = ProcessDataIn4 11 = ProcessDataIn5 12 = ProcessDataIn6 13 = ProcessDataIn7 14 = ProcessDataIn8 15 = Temperature input 1 16 = Temperature input 2 17 = Temperature input 3 18 = Temperature input 4 19 = Temperature input 5 20 = Temperature input 6 21 = Block 1 Out 22 = Block 2 Out 23 = Block 3 Out 24 = Block 4 Out 25 = Block 5 Out 26 = Block 6 Out 27 = Block 7 Out 28 = Block 8 Out 29 = Block 9 Out 30 = Block 10 Out AI's and ProcessDataIn are handled as % (0.00-100.00%) and scaled according to Feedback min and max. <b>NOTE:</b> ProcessDataIn use two decimals. <b>NOTE:</b> If temperature inputs are selected, feedback minimum and maximum scaling parameters needs to be set -50..200 C

Table 89. Feedback settings

P3.13.3.4	Feedback 1 minimum	-200.00	200.00	%	0.00	336	Minimum value at analogue signal minimum.
P3.13.3.5	Feedback 1 maximum	-200.00	200.00	%	100.00	337	Maximum value at analogue signal maximum.
P3.13.3.6	Feedback 2 source selection	0	20		0	335	See P3.13.3.3
P3.13.3.7	Feedback 2 minimum	-200.00	200.00	%	0.00	338	Minimum value at analogue signal minimum.
M3.13.3.8	Feedback 2 maximum	-200.00	200.00	%	100.00	339	Maximum value at analogue signal maximum.

**3.4.26.4 Feedforward**

Feedforward usually needs accurate process models, but in some simple cases a gain + offset type of feedforward is enough. The feedforward part does not use any feedback measurements of the actual controlled process value (water level in the example on page 165). Vacon feedforward control uses other measurements which are indirectly affecting the controlled process value.

Table 90. Feedforward settings

Code	Parameter	Min	Max	Unit	Default	ID	Description
P3.13.4.1	Feedforward function	1	9		1	1059	See P3.13.3.1.
P3.13.4.2	Feedforward function gain	-1000	1000	%	100.0	1060	See P3.13.3.2
P3.13.4.3	Feedforward 1 source selection	0	25		0	1061	See P3.13.3.3
P3.13.4.4	Feedforward 1 minimum	-200.00	200.00	%	0.00	1062	See P3.13.3.4
P3.13.4.5	Feedforward 1 maximum	-200.00	200.00	%	100.00	1063	See P3.13.3.5
P3.13.4.6	Feedforward 2 source selection	0	25		0	1064	See P3.13.3.6
P3.13.4.7	Feedforward 2 min	-200.00	200.00	%	0.00	1065	See P3.13.3.7
P3.13.4.8	Feedforward 2 max	-200.00	200.00	%	100.00	1066	See M3.13.3.8

**3.4.26.5 Sleep function**

This function will put the drive into sleep mode if the frequency stays below the sleep limit for a longer time than that set with the Sleep Delay.

Table 91. Sleep function settings

Code	Parameter	Min	Max	Unit	Default	ID	Description
P3.13.5.1	Sleep frequency limit 1	0.00	320.00	Hz	0.00	1016	Drive goes to sleep mode when the output frequency stays below this limit for a time greater than that defined by parameter <i>Sleep delay</i> .

Table 91. Sleep function settings

P3.13.5.2	Sleep delay 1	0	3000	s	0	1017	The minimum amount of time the frequency has to remain below the Sleep level before the drive is stopped.
P3.13.5.3	Wake-up level 1			Varies	0.0000	1018	Defines the level for the PID feedback value wake-up supervision. Uses selected process units.
P3.13.5.4	Sleep frequency limit 2	0.00	320.00	Hz	0.00	1075	See P3.13.5.1.
P3.13.5.5	Sleep delay 2	0	3000	s	0	1076	See P3.13.5.2.
P3.13.5.6	Wake-up level 2			Varies	0.0000	1077	See P3.13.5.3.

3.4.26.6 Feedback supervision

Feedback supervision is used to control that the *PID Feedback value* (process actual value) stays within predefined limits. With this function you can e.g. detect a major pipe burst and stop unnecessary flooding. See more on page 165.

Table 92. Feedback supervision parameters

Code	Parameter	Min	Max	Unit	Default	ID	Description
P3.13.6.1	Enable feedback supervision	0	1		0	735	0 = Disabled 1 = Enabled
P3.13.6.2	Upper limit	Varies	Varies	Varies	Varies	736	Upper actual/process value supervision
P3.13.6.3	Lower limit	Varies	Varies	Varies	Varies	758	Lower actual/process value supervision
P3.13.6.4	Delay	0	30000	s	0	737	If the desired value is not reached within this time a fault or alarm is created.
P3.13.6.5	Response to PID1 supervision fault	0	3		2	749	0 = No action 1 = Alarm 2 = Fault (Stop according to stop mode) 3 = Fault (Stop by coasting)

3.4.26.7 Pressure loss compensation

Table 93. Pressure loss compensation parameters

Code	Parameter	Min	Max	Unit	Default	ID	Description
P3.13.7.1	Enable setpoint 1	0	1		0	1189	Enables pressure loss compensation for setpoint 1. 0 = Disabled 1 = Enabled
P3.13.7.2	Setpoint 1 max compensation	Varies	Varies	Varies	Varies	1190	Value added proportionally to the frequency. Setpoint compensation = Max compensation * (FreqOut - MinFreq)/(MaxFreq - MinFreq)
P3.13.7.3	Enable setpoint 2	0	1		0	1191	See P3.13.7.1.
P3.13.7.4	Setpoint 2 max compensation	Varies	Varies	Varies	Varies	1192	See P3.13.7.2.



3.4.26.8 Soft fill

The process is brought to a certain level (P3.13.8.3) at slow frequency (P3.13.8.2) before the PID controller starts to control. In addition, you can also set a timeout for the soft fill function. If the set level is not reached within the timeout a fault is triggered. This function can be used e.g. to fill the empty pipe line slowly in order to avoid "water hammers" that could otherwise break the pipes.

It is recommended to use the Soft Fill function always when using the Multi Pump functionality.

Table 94. Soft fill settings

Code	Parameter	Min	Max	Unit	Default	ID	Description
P3.13.8.1	Enable soft fill	0	1		0	1094	0 = Disabled 1 = Enabled
P3.13.8.2	Soft fill frequency	0.00	50.00	Hz	20.00	1055	The drive accelerates to this frequency before starting to control.
P3.13.8.3	Soft fill level	Varies	Varies	Varies	0.0000	1095	The drive runs at the PID start frequency until the feedback reaches this value. At this point the controller starts to regulate (depending on acting mode).
P3.13.8.4	Soft fill timeout	0	30000	s	0	1096	If the desired value is not reached within this time a fault or alarm is created. 0 = No timeout ( <b>NOTE!</b> No fault triggered if value '0' is set)
P3.13.8.5	PID Soft Fill timeout response	0	3		2	738	0 = No action 1 = Alarm 2 = Fault (Stop according to stop mode) 3 = Fault (Stop by coasting)

**3.4.26.9 Input pressure supervision**

The *Input pressure supervision* function is used to supervise that there is enough water in the inlet of the pump, to prevent the pump from sucking air or causing suction cavitation. This function requires a pressure sensor to be installed on the pump inlet, see 29.

If the pump inlet pressure falls below the defined alarm limit, an alarm will be triggered and the pump output pressure reduced by decreasing the PID controller setpoint value. If the inlet pressure still keeps falling below the fault limit, the pump is stopped and a fault will be triggered.

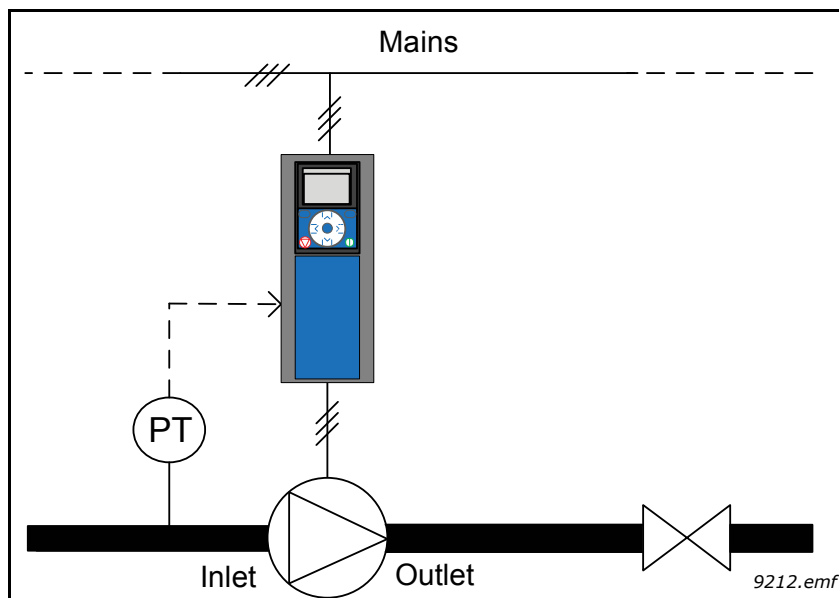

Figure 29. Location of pressure sensor

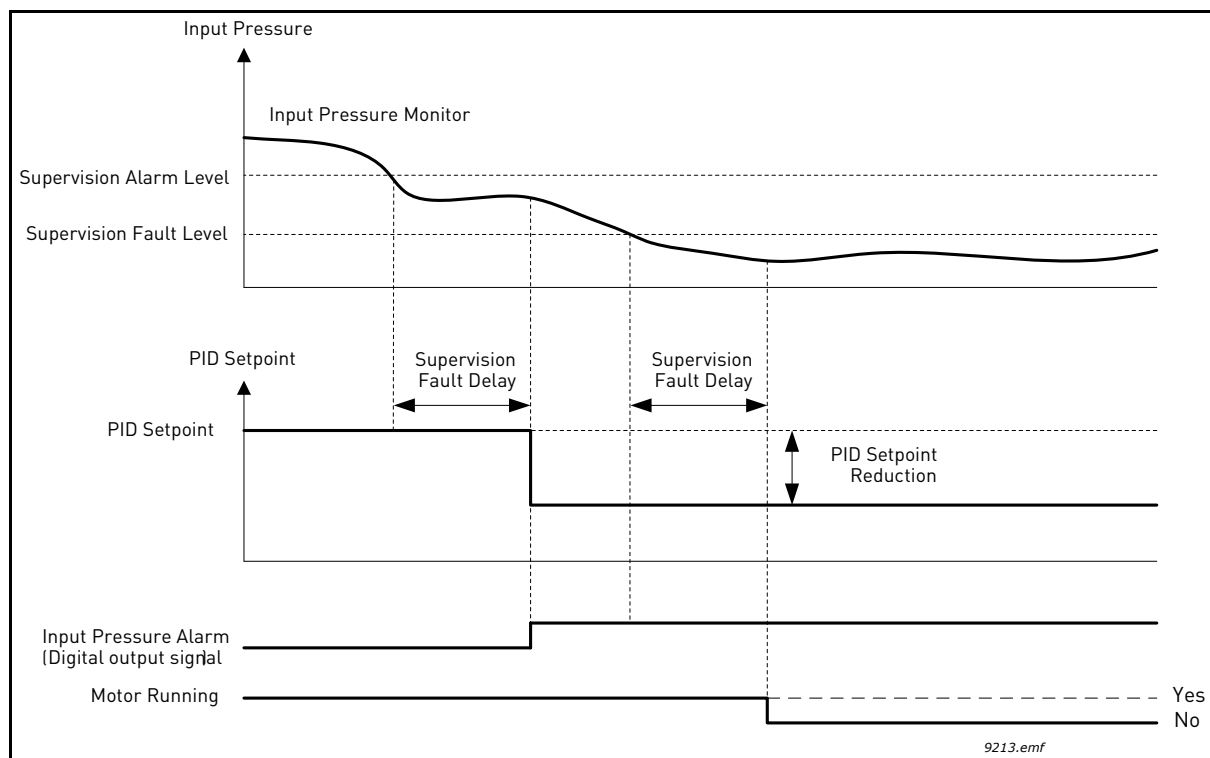

Figure 30. Input pressure supervision

Table 95. Input pressure supervision parameters

Code	Parameter	Min	Max	Unit	Default	ID	Description
P3.13.9.1	Enable supervision	0	1		0	1685	0 = Disabled 1 = Enabled Enables the Input Pressure Supervision.
P3.13.9.2	Supervision signal	0	23		0	1686	The source of input pressure measurement signal: 0=Analogue input 1 1=Analogue input 2 2=Analogue input 3 3=Analogue input 4 4=Analogue input 5 5=Analogue input 6 6=ProcessDataIn1 (0-100%) 7=ProcessDataIn2 (0-100%) 8=ProcessDataIn3 (0-100%) 9=ProcessDataIn4 (0-100%) 10=ProcessDataIn5 (0-100%) 11=ProcessDataIn6 (0-100%) 12=ProcessDataIn7 (0-100%) 13=ProcessDataIn8 (0-100%) 14 = Block 1 Out 15 = Block 2 Out 16 = Block 3 Out 17 = Block 4 Out 18 = Block 5 Out 19 = Block 6 Out 20 = Block 7 Out 21 = Block 8 Out 22 = Block 9 Out 23 = Block 10 Out
P3.13.9.3	Supervision unit selection	0	8	Varies	2	1687	Select unit for supervision. The supervision signal (P3.13.9.2) can be scaled to process units on the panel.
P3.13.9.4	Supervision unit decimals	0	4		2	1688	Choose how many decimals to show.
P3.13.9.5	Supervision unit minimum value	Varies	Varies	Varies	Varies	1689	Unit min and max parameters are the signal values corresponding to e.g. 4mA and 20mA respectively (scaled linearly between these).
P3.13.9.6	Supervision unit maximum value	Varies	Varies	Varies	Varies	1690	
P3.13.9.7	Supervision alarm level	Varies	Varies	Varies	Varies	1691	Alarm (Fault ID 1363) will be launched if supervision signal stays below the alarm level longer than the time defined by parameter P3.13.9.9.
P3.13.9.8	Supervision fault level	Varies	Varies	Varies	Varies	1692	Fault (Fault ID 1409) will be launched if supervision signal stays below the fault level longer than the time defined by parameter P3.13.9.9.

Table 95. Input pressure supervision parameters

Code	Parameter	Min	Max	Unit	Default	ID	Description
P3.13.9.9	Supervision fault delay	0.00	60.00	s	5.00	1693	Delay time to launch the <i>Input pressure supervision alarm</i> or <i>fault</i> if the supervision signal stays below the alarm/fault level longer than defined by this parameter.
P3.13.9.10	PID setpoint reduction	0.0	100.0	%	10.0	1694	Defines the rate of the PID controller setpoint reduction when the Input pressure supervision alarm is active.
V3.13.9.11	Input pressure	Varies	Varies	Varies	Varies	1695	Monitoring value for selected Input pressure supervision signal. Scaling value according to P3.13.9.4.

#### 3.4.26.10 Frost protection

The Frost Protection –function is used to protect the pump from frost damages by running the pump at constant Frost Protection Frequency if the pump is in sleep mode and the measured temperature of the pump goes below defined protection temperature. This function requires a temperature transducer or a temperature sensor to be installed on the pump covering or the pipe line near the pump.

Table 96. Frost protection parameters

Code	Parameter	Min	Max	Unit	Default	ID	Description
P3.13.10.1	Frost protection	0	1		0	1704	0 = Disabled 1 = Enabled
P3.13.10.2	Temperature signal	0	29		6	1705	0=Temperature Input 1 (-50..200 C) 1=Temperature Input 2 (-50..200 C) 2=Temperature Input 3 (-50..200 C) 3=Temperature Input 4 (-50..200 C) 4=Temperature Input 5 (-50..200 C) 5=Temperature Input 6 (-50..200 C) 6=Analogue input 1 7=Analogue input 2 8=Analogue input 3 9=Analogue input 4 10=Analogue input 5 11=Analogue input 6 12=ProcessDataIn1 (0-100%) 13=ProcessDataIn2 (0-100%) 14=ProcessDataIn3 (0-100%) 15=ProcessDataIn4 (0-100%) 16=ProcessDataIn5 (0-100%) 17=ProcessDataIn6 (0-100%) 18=ProcessDataIn7 (0-100%) 19=ProcessDataIn8 (0-100%) 20 = Block 1 Out 21 = Block 2 Out 22 = Block 3 Out 23 = Block 4 Out 24 = Block 5 Out 25 = Block 6 Out 26 = Block 7 Out 27 = Block 8 Out 28 = Block 9 Out 29 = Block 10 Out
P3.13.10.3	Temperature signal minimum	-100.0	P3.13.10.4	°C/°F	-50.0 (°C)	1706	Temperature value corresponding to minimum value of selected temperature signal.
P3.13.10.4	Temperature signal maximum	P3.13.10.3	300.0	°C/°F	200.0 (°C)	1707	Temperature value corresponding to maximum value of selected temperature signal.
P3.13.10.5	Frost Protection Temperature	P3.13.10.3	P3.13.10.4	°C/°F	5.00	1708	Temperature limit below which the Frost Protection function will be activated.
P3.13.10.6	Frost Protection Frequency	0.0	Varies	Hz	10.0	1710	Constant frequency reference which is used when the Frost Protection function is activated
V3.13.10.7	Frost temperature monitoring	Varies	Varies	°C/°F		1711	Monitoring value for measured temperature signal in Frost Protection function. Scaling value: 0.1

**3.4.27 GROUP 3.14: EXTERNAL PID-CONTROLLER****3.4.27.1 Basic settings**

For more detailed information, see chapter 3.4.26.

*Table 97. Basic settings for external PID-controller*

Code	Parameter	Min	Max	Unit	Default	ID	Description
P3.14.1.1	Enable external PID	0	1		0	1630	0 = Disabled 1 = Enabled
P3.14.1.2	Start signal				DigIN Slot0.2	1049	FALSE = PID2 in stop mode TRUE = PID2 regulating This parameter will have no effect if PID2 controller is not enabled in the Basic menu for PID2
P3.14.1.3	Output in Stop	0.0	100.0	%	0.0	1100	The output value of the PID controller in % of its maximum output value while it is stopped from digital input
P3.14.1.4	PID gain	0.00	1000.00	%	100.00	1631	
P3.14.1.5	PID integration time	0.00	600.00	s	1.00	1632	
P3.14.1.6	PID derivation time	0.00	100.00	s	0.00	1633	
P3.14.1.7	Process unit selection	0	37		0	1635	
P3.14.1.8	Process unit min	Varies	Varies	Varies	0	1664	
P3.14.1.9	Process unit max	Varies	Varies	Varies	100	1665	
P3.14.1.10	Process unit decimals	0	4		2	1666	
P3.14.1.11	Error inversion	0	1		0	1636	
P3.14.1.12	Dead band	Varies	Varies	Varies	0.0	1637	
P3.14.1.13	Dead band delay	0.00	320.00	s	0.00	1638	

3.4.27.2 Setpoints

Table 98. External PID-controller, setpoints

Code	Parameter	Min	Max	Unit	Default	ID	Description
P3.14.2.1	Keypad setpoint 1	0.00	100.00	Varies	0.00	1640	
P3.14.2.2	Keypad setpoint 2	0.00	100.00	Varies	0.00	1641	
P3.14.2.3	Setpoint ramp time	0.00	300.00	s	0.00	1642	
P3.14.2.4	Select setpoint	Varies	Varies		DigIN Slot0.1	1048	FALSE = Setpoint 1 TRUE = Setpoint 2
P3.14.2.5	Setpoint source 1 selection	0	32		1	1643	0 = Not Used 1 = Keypad Setpoint 1 2 = Keypad Setpoint 2 3 = AI1 4 = AI2 5 = AI3 6 = AI4 7 = AI5 8 = AI6 9 = ProcessDataIn1 10 = ProcessDataIn2 11 = ProcessDataIn3 12 = ProcessDataIn4 13 = ProcessDataIn5 14 = ProcessDataIn6 15 = ProcessDataIn7 16 = ProcessDataIn8 17 = Temperature Input 1 18 = Temperature Input 2 19 = Temperature Input 3 20 = Temperature Input 4 21 = Temperature Input 5 22 = Temperature Input 6 23 = Block 1 Out 24 = Block 2 Out 25 = Block 3 Out 26 = Block 4 Out 27 = Block 5 Out 28 = Block 6 Out 29 = Block 7 Out 30 = Block 8 Out 31 = Block 9 Out 32 = Block 10 Out AI's and ProcessDataIn are handled as percent (0.00-100.00%) and scaled according to Setpoint minimum and maximum. <b>NOTE:</b> ProcessDataIn signals use 2 decimals. <b>NOTE:</b> If temperature inputs are selected, setpoint minimum and maximum scaling parameters needs to be set -50..200 C
P3.14.2.6	Setpoint 1 minimum	-200.00	200.00	%	0.00	1644	Minimum value at analogue signal minimum.
P3.14.2.7	Setpoint 1 maximum	-200.00	200.00	%	100.00	1645	Maximum value at analogue signal maximum.

Table 98. External PID-controller, setpoints

P3.14.2.8	Setpoint source 2 selection	0	22		0	1646	See P3.14.2.5.
P3.14.2.9	Setpoint 2 minimum	-200.00	200.00	%	0.00	1647	Minimum value at analogue signal minimum.
P3.14.2.10	Setpoint 2 maximum	-200.00	200.00	%	100.00	1648	Maximum value at analogue signal maximum.



3.4.27.3 Feedbacks

For more detailed information, see chapter 3.4.26.

*Table 99. External PID-controller, feedbacks*

Code	Parameter	Min	Max	Unit	Default	ID	Description
P3.14.3.1	Feedback function	1	9		1	1650	
P3.14.3.2	Feedback function gain	-1000.0	1000.0	%	100.0	1651	
P3.14.3.3	Feedback 1 source selection	0	25		1	1652	See P3.13.3.3.
P3.14.3.4	Feedback 1 minimum	-200.00	200.00	%	0.00	1653	Minimum value at analogue signal minimum.
P3.14.3.5	Feedback 1 maximum	-200.00	200.00	%	100.00	1654	Maximum value at analogue signal maximum.
P3.14.3.6	Feedback 2 source selection	0	25		2	1655	See P3.13.3.6.
P3.14.3.7	Feedback 2 minimum	-200.00	200.00	%	0.00	1656	Minimum value at analogue signal minimum.
P3.14.3.8	Feedback 2 maximum	-200.00	200.00	%	100.00	1657	Maximum value at analogue signal maximum.

3.4.27.4 Process supervision

For more detailed information, see chapter 3.4.26.

*Table 100. External PID-controller, process supervision*

Code	Parameter	Min	Max	Unit	Default	ID	Description
P3.14.4.1	Enable supervision	0	1		0	1659	0 = Disabled 1 = Enabled
P3.14.4.2	Upper limit	Varies	Varies	Varies	Varies	1660	
P3.14.4.3	Lower limit	Varies	Varies	Varies	Varies	1661	
P3.14.4.4	Delay	0	30000	s	0	1662	If the desired value is not reached within this time a fault or alarm is activated.
P3.14.4.5	Response to external PID supervision fault	0	3		2	757	See P3.9.1.2

**3.4.28 GROUP 3.15: MULTI-PUMP**

The Multi-pump functionality allows you to control up to 4 motors (pumps, fans) with PID controller 1. The AC drive is connected to one motor which is the "regulating" motor connecting and disconnecting the other motors to/from the mains, by means of contactors controlled with relays when needed in order to maintain the right setpoint. The Autochange function controls the order/priority in which the motors are started in order to guarantee their equal wear. The controlling motor can be included in the autochange and interlocks logic, or, it may be selected to always functions as Motor 1. Motors can be taken out of use momentarily, e.g. for service, using the motor Interlock function. See page 170.

*Table 101. Multi-pump parameters*

Code	Parameter	Min	Max	Unit	Default	ID	Description
P3.15.1	Number of motors	1	6		1	1001	Total number of motors (pumps/fans) used in multi-pump system
P3.15.2	Interlock function	0	1		1	1032	Enable/Disable use of interlocks. Interlocks are used to tell the system if a motor is connected or not. 0 = Disabled 1 = Enabled
P3.15.3	Include FC	0	1		1	1028	Include the AC drive in the autochange and interlocking system. 0 = Disabled 1 = Enabled
P3.15.4	Autochange	0	1		1	1027	Disable/enable rotation of starting order and priority of motors. 0 = Disabled 1 = Enabled
P3.15.5	Autochange interval	0.0	3000.0	h	48.0	1029	After the expiry of the time defined with this parameter, the autochange function takes place if the capacity used lies below the level defined with parameters P3.15.6 and P3.15.7.
P3.15.6	Autochange: Frequency limit	0.00	P3.3.1.2	Hz	25.00	1031	These parameters define the level below which the capacity used must remain so that the autochange can take place.
P3.15.7	Autochange: Motor limit	1	6		1	1030	
P3.15.8	Bandwidth	0	100	%	10	1097	Percentage of the setpoint. E.g.: Setpoint = 5 bar, Bandwidth = 10%: As long as the feedback value stays within 4.5...5.5 bar motor disconnection or removal will not take place.
P3.15.9	Bandwidth delay	0	3600	s	10	1098	With feedback outside the bandwidth, this time must pass before pumps are added or removed.
P3.15.10	Motor 1 interlock	Varies	Varies		DigIN Slot0.1	426	FALSE = Not active TRUE = Active



Table 101. Multi-pump parameters

Code	Parameter	Min	Max	Unit	Default	ID	Description
P3.15.11	Motor 2 interlock	Varies	Varies		DigIN Slot0.1	427	FALSE = Not active TRUE = Active
P3.15.12	Motor 3 interlock	Varies	Varies		DigIN Slot0.1	428	FALSE = Not active TRUE = Active
P3.15.13	Motor 4 interlock	Varies	Varies		DigIN Slot0.1	429	FALSE = Not active TRUE = Active
P3.15.14	Motor 5 interlock	Varies	Varies		DigIN Slot0.1	430	FALSE = Not active TRUE = Active
P3.15.15	Motor 6 interlock	Varies	Varies		DigIN Slot0.1	486	FALSE = Not active TRUE = Active
M3.15.16	Overpressure supervision	See chapter 3.4.28.1 below.					

**3.4.28.1 Overpressure supervision**

The *Overpressure supervision* function is used for pressure supervision in a Multi-Pump system. E.g. when the main valve of the pump system is rapidly closed the pressure in the pipelines will increase quickly. The pressure might even rise too fast for the PID controller to react. The Overpressure supervision is used to prevent the pipes from bursting by quickly stopping the running of auxiliary motors in the Multi-Pump system.

Table 102. Overpressure supervision parameters

Code	Parameter	Min	Max	Unit	Default	ID	Description
P3.15.16.1	Enable overpressure supervision	0	1		0	1698	0 = Disabled 1 = Enabled
P3.15.16.2	Supervision alarm level	0.00	100.00	%	0.00	1699	Set the overpressure alarm level here.

**3.4.29 GROUP 3.16: MAINTENANCE COUNTERS**

The maintenance counter is a way of indicating the operator that maintenance needs to be carried out. For example, a belt needs to be replaced or oil in a gearbox should be changed.

There are two different modes for the maintenance counters, hours or revolutions\*1000. The counters are only incremented during Run mode in either case. **NOTE:** Revolutions are based on motor speed which is only an estimate (integration every second).

When the counter exceeds the limit an alarm or fault will be triggered respectively. Individual maintenance alarm and fault signals can be connected to a digital/relay output.

When maintenance has been carried out the counter can be reset through either a digital input or a parameter B3.16.4.

*Table 103. Maintenance counter parameters*

Code	Parameter	Min	Max	Unit	Default	ID	Description
P3.16.1	Counter 1 mode	0	2		0	1104	0 = Not used 1 = Hours 2 = Revolutions*1000
P3.16.2	Counter 1 alarm limit	214748 3647	80000	h/kRev	0	1105	When to trig a maintenance alarm for counter 1. 0 = Not used
P3.16.3	Counter 1 fault limit	214748 3647	80000	h/kRev	0	1106	When to trig a maintenance fault for counter 1. 0 = Not used
B3.16.4	Counter 1 reset	0	1		0	1107	Activate to reset counter 1.
P3.16.5	Counter 1 DI reset	Varies	Varies		0	490	TRUE = Reset

**3.4.30 GROUP 3.17: FIRE MODE**

When the *Fire mode* is activated the drive will reset all upcoming faults and continue running at the given speed as long as it is possible. The drive ignores all commands from keypad, field-buses and PC tool, excluding *Fire mode activation*, *Fire mode reverse*, *Run enable*, *Run interlock1* and *Run interlock 2* signals from I/O.

The Fire mode function has two operational modes, *Test* mode and *Enabled* mode. The operational mode can be selected by entering different passwords to parameter P3.17.1. In the Test mode, upcoming errors will not be reset automatically and the drive will stop when faults occur.

When the Fire mode function is activated, an alarm is shown on the keypad.

**NOTE! THE WARRANTY IS VOID IF THIS FUNCTION IS ACTIVATED!** Test Mode can be used to test the Fire Mode -function without voiding the warranty. For more information and a more detailed description of this function, see page 176.

*Table 104. Fire mode parameters*

Code	Parameter	Min	Max	Unit	Default	ID	Description
P3.17.1	Fire Mode password	0	9999		0	1599	1002 = Enabled 1234 = Test mode
P3.17.2	Fire Mode frequency source	0	18		0	1617	Selection of reference source when Fire Mode is active. This enables selection of e.g. AI1 or PID controller as reference source also while operating in Fire Mode. 0 = Fire Mode frequency 1 = Preset speeds 2 = Keypad 3 = Fieldbus 4 = AI1 5 = AI2 6 = AI1 + AI2 7 = PID1 8 = Motor potentiometer 9 = Block 1 Out 10 = Block 2 Out 11 = Block 3 Out 12 = Block 4 Out 13 = Block 5 Out 14 = Block 6 Out 15 = Block 7 Out 16 = Block 8 Out 17 = Block 9 Out 18 = Block 10 Out
P3.17.3	Fire Mode frequency	8.00	P3.3.1.2	Hz	50.00	1598	Frequency used when Fire Mode is activated.
P3.17.4	Fire Mode activation on OPEN				DigIN Slot0.2	1596	FALSE = Fire Mode active TRUE = No action
P3.17.5	Fire Mode activation on CLOSE				DigIN Slot0.1	1619	FALSE = No action TRUE = Fire Mode active
P3.17.6	Fire Mode reverse				DigIN Slot0.1	1618	Reverse command of rotation direction while running in Fire Mode. This function has no effect in normal operation. DigIN Slot0.1 = Forward DigIN Slot0.2 = Reverse



Table 104. Fire mode parameters

V3.17.7	Fire Mode status	0	3		0	1597	Monitoring value (see also Table 22) 0=Disabled 1=Enabled 2=Activated (Enabled + DI Open) 3=Test Mode Scaling value: 1
V3.17.8	Fire Mode counter					1679	Shows how many times the Fire mode has been activated in Enabled mode. This counter cannot be reset. Scaling value: 1

**3.4.31 GROUP 3.18: MOTOR PREHEAT PARAMETERS**

Motor Preheat function is intended to keep the drive and motor warm in Stop state by injecting DC current to the motor e.g. to prevent condensation. Motor preheat can be activated either always in Stop state, by digital input or when drive heatsink temperature or motor temperature goes below a defined temperature.

Table 105. Motor preheat parameters

Code	Parameter	Min	Max	Unit	Default	ID	Description
P3.18.1	Motor preheat function	0	4		0	1225	0 = Not used 1 = Always in stop state 2 = Controlled by DI 3 = Temperature limit 4 = Temperature limit (Measured motor temperature) <b>NOTE!</b> Function 4 requires temperature measurement option board to be installed.
P3.18.2	Preheat temperature limit	-20	100	°C	0	1226	<i>Motor preheat</i> switches on when the heatsink temperature or measured motor temperature goes below this level provided that P3.18.1 is set to selections 3 or 4.
P3.18.3	Motor preheat current	0	1.85	A	Varies	1227	DC current for pre-heating of motor and drive in stop state. Activated according to P3.18.1.
P3.18.4	Motor preheat ON	Varies	Varies		DigIN Slot0.1	1044	FALSE = No action TRUE = Preheat activated in Stop state Used when parameter P3.18.1 is set to 2. <b>NOTE!</b> Also <i>Time channels</i> can be connected to PreHeat ON provided that DIN Control (selection 2 for parameter P3.18.1) is used.
P3.18.5	Preheat motor temperature	0	6		0	1045	Motor temperature measurement signal selection. 0 = Not Used 1 = Temperature Input 1 2 = Temperature Input 2 3 = Temperature Input 3 4 = Temperature Input 4 5 = Temperature Input 5 6 = Temperature Input 6 <b>NOTE!</b> This parameter is not available if temperature measurement option board is not installed.



3.4.32 GROUP 3.20: MECHANICAL BRAKE

Mechanical brake control is used to control an external mechanical brake by a digital output signal. Brake open/close command can be selected as a function of the digital output. The status of the mechanical brake can also be supervised if a brake feedback signal is connected to one of the drive's digital inputs and the supervision is enabled.

Table 106. Mechanical brake parameters

Code	Parameter	Min	Max	Unit	Default	ID	Description
P3.20.1	Brake control	0	2		0	1541	0 = Disabled 1 = Enabled 2 = Enabled with brake status supervision
P3.20.2	Brake mechanical delay	0.00	60.00	s	0.00	353	Mechanical delay required to open the brake
P3.20.3	Brake opening frequency limit	P3.20.4	P3.3.1.2	Hz	2.00	1535	Frequency limit for opening the mechanical brake
P3.20.4	Brake closing frequency limit	P3.3.1.1	P3.3.1.2	Hz	2.00	1539	Frequency limit for closing the mechanical brake
P3.20.5	Brake current limit	0.0	Varies	A	0.0	1085	Mechanical brake will close immediately if motor current is below this value.
P3.20.6	Brake fault delay	0.00	60.00	s	2.00	352	If correct brake feedback signal is not received within this delay a brake fault is generated. <b>NOTE!</b> This delay is only used if the value of par. P3.20.1 is set to 2.
P3.20.7	Response to Brake fault	0	3		0	1316	0 = No action 1 = Alarm 2 = Fault (Stop according to stop mode) 3 = Fault (Stop by coasting)
P3.20.8	Brake feedback				DigIN Slot0.1	1210	Connect this input signal to the auxiliary contact of the mechanical brake. If the contact is not closed within given time the drive will generate a brake fault.





3.4.33 GROUP 3.21: PUMP CONTROL

3.4.33.1 Auto-cleaning

The Auto-cleaning function is used to remove any dirt or other material that may have attached to the pump impeller. Auto-cleaning is used e.g. in wastewater systems to keep up the performance of the pump. Auto Cleaning function can also be used to clear the blocked pipe or valve.

Table 107. Auto-cleaning parameters

Code	Parameter	Min	Max	Unit	Default	ID	Description
P3.21.1.1	Cleaning function	0	1		0	1714	0=Disabled 1=Enabled
P3.21.1.2	Cleaning activation				DigIN Slot0.1	1715	Digital input signal used to start the Auto Cleaning sequence. Auto-cleaning sequence will be aborted if activation signal is removed before the sequence has been completed. <b>NOTE:</b> The drive will start if the input is activated!
P3.21.1.3	Cleaning cycles	1	100		5	1716	Number of forward/reverse cleaning cycles.
P3.21.1.4	Clean forward frequency	0.00	50.00	Hz	45.00	1717	Forward direction frequency in Auto-cleaning cycle.
P3.21.1.5	Clean forward time	0.00	320.00	s	2.00	1718	Running time for forward direction frequency in Auto-cleaning cycle.
P3.21.1.6	Clean reverse frequency	0.00	50.00	Hz	45.00	1719	Reverse direction frequency in Auto-cleaning cycle.
P3.21.1.7	Clean reverse time	0.00	320.00	s	0.00	1720	Running time for reverse direction frequency in Auto-cleaning cycle
P3.21.1.8	Cleaning acceleration time	0.1	300.0	s	0.1	1721	Motor acceleration time when Auto-cleaning is active
P3.21.1.9	Cleaning deceleration time	0.1	300.0	s	0.1	1722	Motor deceleration time when Auto-cleaning is active

3.4.33.2 *Jockey pump*

Jockey pump is a smaller pump used to keep up the pressure in the pipeline e.g. during night time when the main pump is in sleep mode.

Table 108. Jockey pump parameters

Code	Parameter	Min	Max	Unit	Default	ID	Description
P3.21.2.1	Jockey function	0	2		0	1674	0 = Not used 1 = PID sleep: Jockey pump runs continuously when PID sleep is active 2 = PID sleep (level): Jockey pump starts at predefined levels when PID sleep is active
P3.21.2.2	Jockey start level	0.00	100.00	%	0.00	1675	Jockey pump will start when PID Sleep is active and PID feedback signal goes below the level defined by this parameter. <b>NOTE!</b> This parameter is used only if P3.21.2.1 = 2 (PID Sleep(Level))
P3.21.2.3	Jockey stop level	0.00	100.00	%	0.00	1676	Jockey pump will stop when PID Sleep is active and PID feedback signal exceeds the level defined by this parameter or PID-controller wakes from sleep. <b>NOTE!</b> This parameter is used only if P3.21.2.1 = 2 PID Sleep(Level)



3.4.33.3 Priming pump

Priming pump is a smaller pump which is used to prime the inlet of the bigger main pump to prevent the main pump from sucking air.

The priming pump function is used to control a smaller priming pump by the digital output signal. A delay time can be defined to start the priming pump before the main pump is started. Priming pump will run continuously as long the main pump is running.

*Table 109. Priming pump parameters*

Code	Parameter	Min	Max	Unit	Default	ID	Description
P3.21.3.1	Priming function	0	1		0	1677	0=Disabled 1=Enabled
P3.21.3.2	Priming time	0.0	320.0	s	3.0	1678	Defines the time to start the priming pump before the main pump is started.



### 3.5 ADDITIONAL PARAMETER INFORMATION

Due to its user-friendliness and simplicity of use, the most parameters of the Vacon 100 Application only require a basic description which is given in the parameter tables in chapter 3.4.13.

In this chapter, you will find additional information on certain most advanced parameters of the Vacon 100 Application. Should you not find the information you need contact your distributor.

#### P3.1.1.2 MOTOR NOMINAL FREQUENCY

**NOTE!** When this parameter is changed, parameters P3.1.4.2 and P3.1.4.3 will be automatically initialized depending on the selected motor type. See Table 112.

##### P3.1.2.1 CONTROL MODE

Table 110.

Selection number	Selection name	Description
0	U/f control (open loop)	Drive frequency reference is set to output frequency without slip compensation. Motor actual speed is finally defined by motor load.
1	Speed control (open loop)	Drive frequency reference is set to motor speed reference. The motor speed is remains the same regardless of motor load. Slip is compensated.
2	Torque control (open loop)	Speed reference is used as maximum speed limit and the motor produces torque within speed limit to achieve torque reference.

##### P3.1.2.2 MOTOR TYPE

This parameter defines the used motor type.

Table 111.

Selection number	Selection name	Description
0	Induction motor (IM)	Select if an induction motor is used.
1	Permanent Magnet Motor (PM)	Select if a permanent magnet motor is used.

When this parameter is changed, parameters P3.1.4.2 and P3.1.4.3 will be automatically initialized according to the selected motor type.

See Table 112 for the initialization values:

Table 112.

Parameter	Induction Motor (IM)	Permanent Magnet Motor (PM)
P3.1.4.2 (Field weakening point frequency)	Motor nominal frequency	Internally calculated
P3.1.4.3 (Voltage at field weakening point)	100,0%	Internally calculated

**P3.1.2.4 IDENTIFICATION**

The automatic motor identification calculates or measures the motor parameters that are needed for optimum motor and speed control.

Identification Run is a part of tuning the motor and the drive specific parameters. It is a tool for commissioning and service of the drive with the aim to find as good parameter values as possible for most drives.

**NOTE:** Motor nameplate parameters has to be set before executing the identification run.

Table 113.

Selection number	Selection name	Description
0	No action	No identification requested.
1	Identification at standstill	The drive is run without speed to identify the motor parameters. The motor is supplied with current and voltage but with zero frequency. U/f ratio is identified.
2	Identification with motor rotating	The drive is run with speed to identify the motor parameters. U/f ratio and magnetization current are identified. <b>NOTE:</b> This identification run must be performed with no load on the motor shaft for accurate results.

The automatic identification is activated by setting this parameter to desired value and giving a start command in the requested direction. The start command to the drive has to be given within 20 s. If no start command is given within this time the identification run is cancelled, the parameter will be reset to its default setting and an *Identification* alarm will be launched.

The identification run can be stopped at any time with normal stop command and the parameter is reset to its default setting. An *Identification* alarm will be launched if the identification run has failed.

**NOTE:** New start command (Rising edge) is required to start the drive after identification.

**P3.1.2.6 MOTOR SWITCH**

This function is typically used if there is a switch between the drive and the motor. Such switches are often found in residential and industrial applications to make sure that an electrical circuit can be completely de-energized from the motor for service or maintenance.

When this parameter is enabled and the motor switch is opened to disconnect the running motor, the drive detects the loss of motor without tripping. It is not necessary to make any changes in the run command or the reference signal to the drive from the process control station. When the motor is re-connected after completed maintenance by closing the switch, the drive detects the motor connection and runs the motor to the reference speed as per the process commands.

If the motor is rotating when re-connected, the drive detects the speed of the running motor through its *Flying start* feature and then controls it to desired speed as per the process commands.

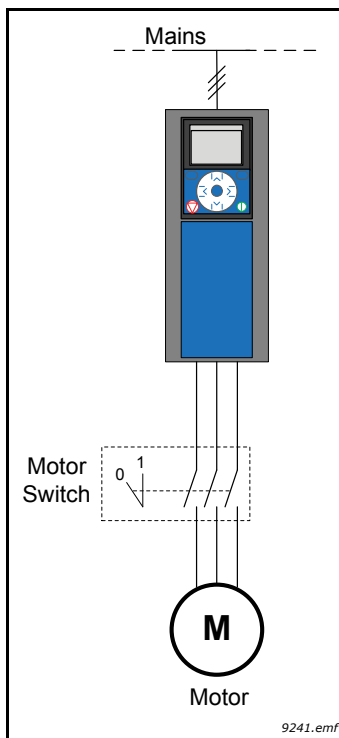

Figure 31. Motor switch

**P3.1.2.7 LOAD DROOPING**

The drooping function enables speed drop as a function of load. This parameter sets that amount corresponding to the nominal torque of the motor.

This function is used e.g. when balanced load is needed for mechanically connected motors or dynamic speed drooping is needed because of changing load.

E.g. if load drooping is set to 10% for a motor with a nominal frequency of 50 Hz and the motor is loaded with nominal load (100 % of torque) the output frequency is allowed to decrease 5 Hz from the frequency reference.

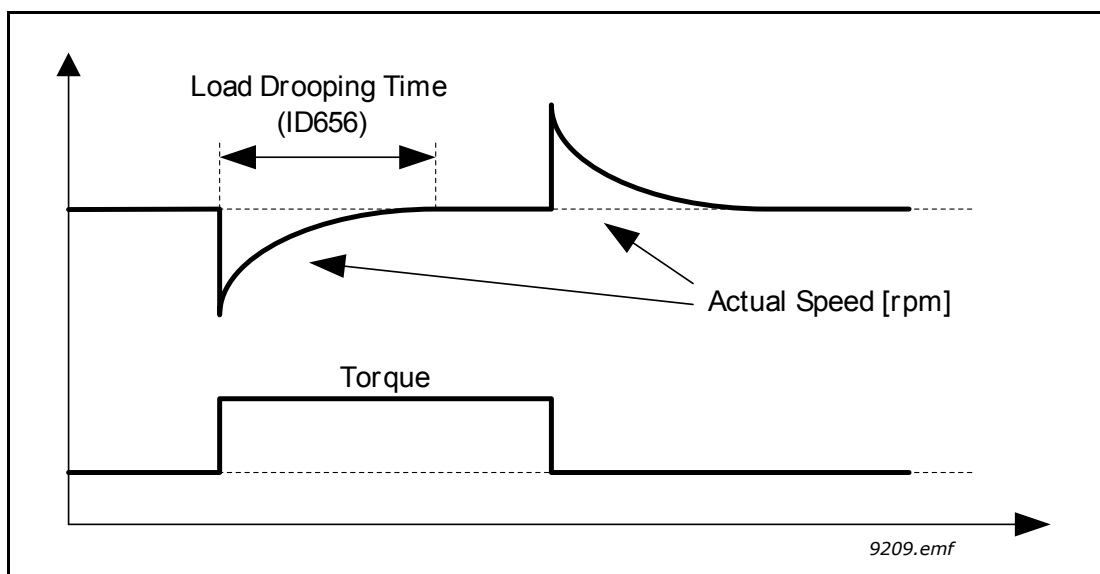

Figure 32. Load drooping

**P3.1.2.10    OVERVOLTAGE CONTROL****P3.1.2.11    UNDERVOLTAGE CONTROL**

These parameters allow the under-/overvoltage controllers to be switched out of operation. This may be useful, for example, if the mains supply voltage varies more than -15% to +10% and the application will not tolerate this over-/undervoltage. In this case, the regulator controls the output frequency taking the supply fluctuations into account.

**P3.1.2.13    STATOR VOLTAGE ADJUST**

**NOTE!** This parameter will be automatically set during the identification run. It is recommended to make the identification run, if possible. See parameter P3.1.2.4.

*Stator voltage adjust* parameter is used only when *Permanent magnet motor (PM motor)* has been selected for parameter P3.1.2.2. This parameter has no affect if *Induction motor* has been selected. With an induction motor in use, the value has been internally forced to 100% and it cannot be changed.

When the value of parameter P3.1.2.2 (Motor type) parameter is changed to *PMS Motor*, the parameters P3.1.4.2 (Field weakening point frequency) and P3.1.4.3 (Voltage at field weakening point) will be automatically extended up to the limits of the drive's full output voltage, retaining the defined U/f-ratio. This internal extension is done to avoid running the PMS motor in the field weakening area because the PMS motor nominal voltage is typically much lower than the full output voltage capability of the drive.

PMS motor nominal voltage typically represents the motor's back-EMF voltage at nominal frequency, but depending on the motor manufacturer, it may represent e.g. the stator voltage at nominal load.

This parameter gives an easy way to adjust the drive's U/f curve near to the motor's back-EMF curve without needing to change several U/f curve parameters.

The Stator voltage adjust parameter defines the drive's output voltage in percent of the motor's nominal voltage at the motor's nominal frequency.

The U/f curve of the drive is typically tuned slightly above the back-EMF curve of the motor. The motor current increases the more the drive's U/f-curve differs from the motor's back-EMF - curve.

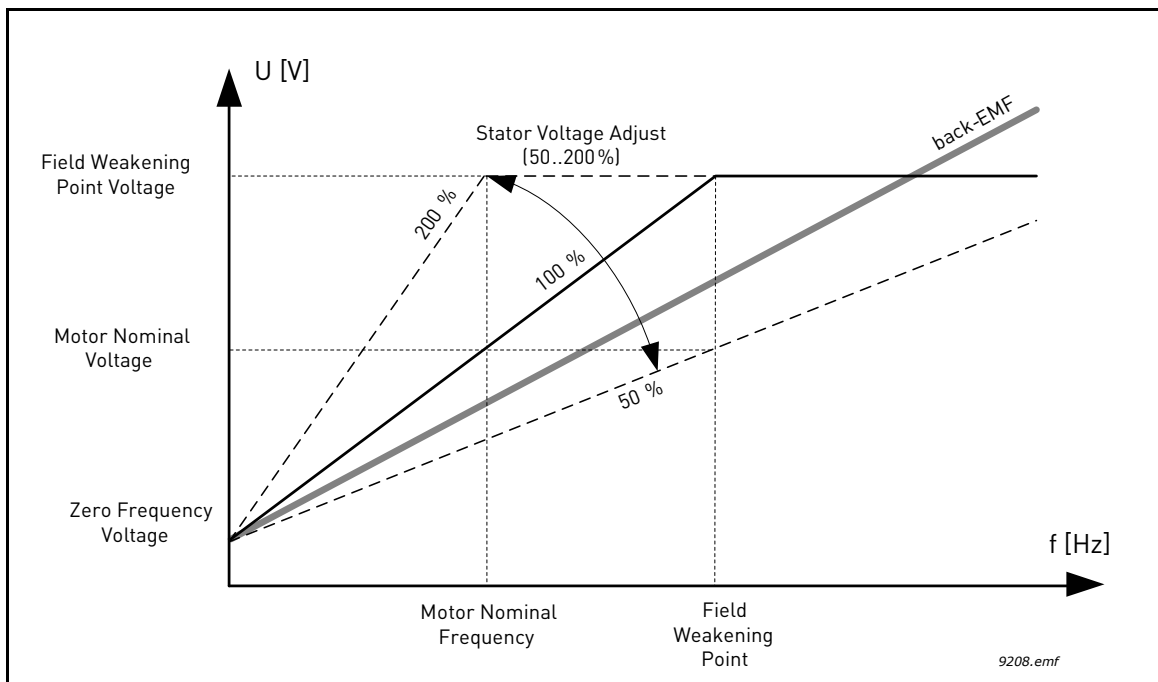

Figure 33. Principle of Stator voltage adjustment

**P3.1.3.1 MOTOR CURRENT LIMIT**

This parameter determines the maximum motor current from the AC drive. The parameter value range differs from size to size.

When the current limit is active the drive output frequency is decreased.

**NOTE:** This is not an overcurrent trip limit.

**P3.1.4.1 U/F RATIO**

Table 114.

Selection number	Selection name	Description
0	Linear	The voltage of the motor changes linearly as a function of output frequency from zero frequency voltage (P3.1.4.6) to the field weakening point (FWP) voltage (P3.1.4.3) at FWP frequency (P3.1.4.2) This default setting should be used if there is no special need for another setting.
1	Squared	The voltage of the motor changes from zero point voltage (P3.1.4.6) following a squared curve form from zero to the field weakening point (P3.1.4.2) The motor runs undermagnetised below the field weakening point and produces less torque. Squared U/f ratio can be used in applications where torque demand is proportional to the square of the speed, e.g. in centrifugal fans and pumps.



Table 114.

Selection number	Selection name	Description
2	Programmable	The U/f curve can be programmed with three different points (see 35 ): Zero frequency voltage (P1), Midpoint voltage/frequency (P2) and Fieldweakening point (P3). Programmable U/f curve can be used if more torque is needed at low frequencies. The optimal settings can automatically be achieved with Motor identification run (P3.1.2.4).

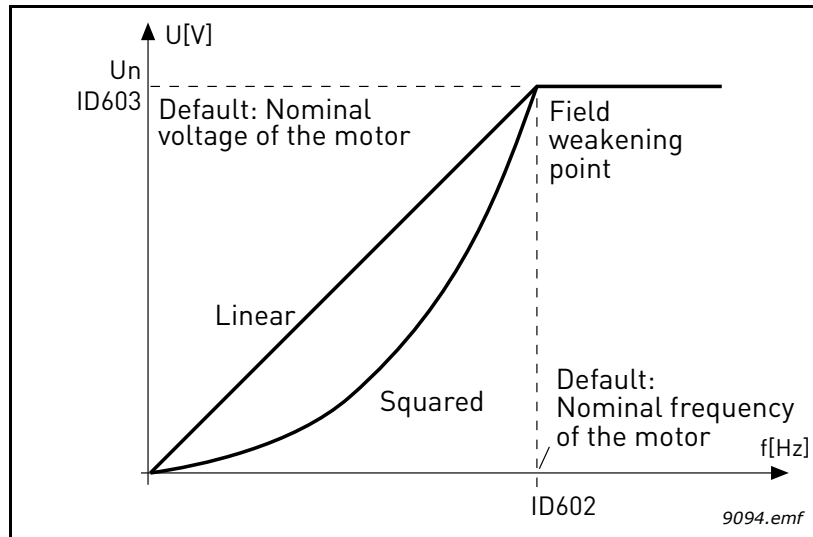

Figure 34. Linear and squared change of motor voltage

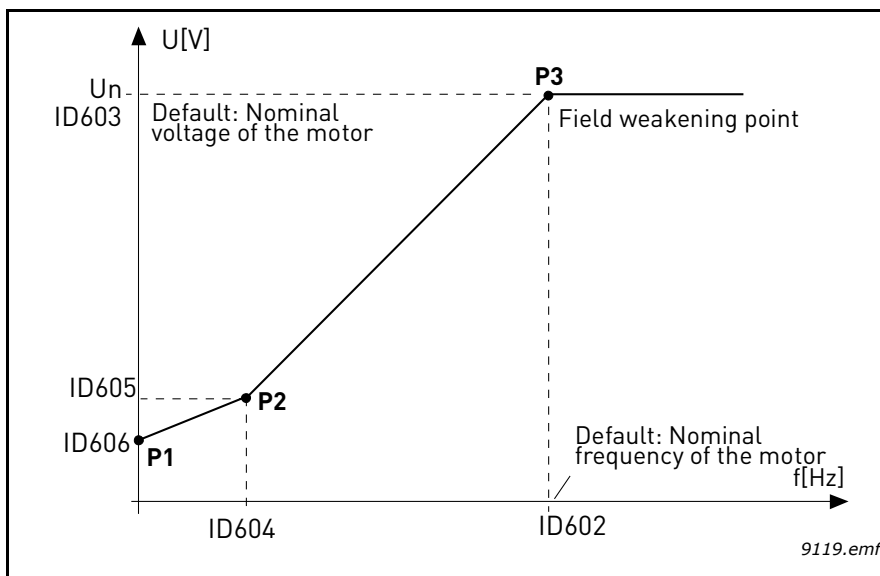

Figure 35. Programmable U/f curve

<b>NOTE!</b>	This parameter is forced to value '1' <i>Linear</i> when parameter <i>Motor type</i> is set to value '1' <i>Permanent Magnet Motor (PM)</i> .
<b>NOTE!</b>	When this parameter is changed, parameters P3.1.4.2, P3.1.4.3, P3.1.4.4, P3.1.4.5 and P3.1.4.6 will be automatically set to their default values if parameter P3.1.2.2 is set to '0' <i>Induction Motor (IM)</i> .

**P3.1.4.3 VOLTAGE AT FIELD WEAKENING POINT**

Above the frequency at the field weakening point, the output voltage remains at the set maximum value. Below the frequency at the field weakening point, the output voltage depends on the setting of the U/f curve parameters. See parameters P3.1.4.1, P3.1.4.4 and P3.1.4.5.

When the parameters P3.1.1.1 and P3.1.1.2 (*Motor nominal voltage* and *Motor nominal frequency*) are set, the parameters P3.1.4.2 and P3.1.4.3 are automatically given the corresponding values. If you need different values for the field weakening point and the maximum output voltage, change these parameters **after** setting the parameters P3.1.1.1 and P3.1.1.2.

**P3.1.4.9 AUTOMATIC TORQUE BOOST**

Automatic torque boost can be used in applications where starting torque is high due to starting friction, e.g. in conveyors.

The voltage to the motor changes proportionally to required torque which makes the motor produce more torque at start and when running at low frequencies.

Even with linear U/f curve, the torque boost has an affect but the best result will be achieved after the identification run when programmable U/f curve is activated.

**P3.1.4.12.1 I/F START**

If the function is activated, the drive is set to current control mode and a constant current defined by P3.1.4.11.3 is fed to the motor until the drive output frequency exceeds the level defined with P3.1.4.11.2. When the output frequency has increased above I/f Start Frequency level, drive operation mode is changed smoothly back to normal U/f –control mode.

**P3.1.4.12.2 I/F START FREQUENCY**

I/f start function is used when the drive’s output frequency is below this frequency limit. When the output frequency exceeds this limit, the drive operation mode is changed back to normal U/f control mode.

**P3.1.4.12.3 I/F START CURRENT**

This parameter defines the current to be fed to the motor when the I/f start function is activated.

**P3.2.5 STOP FUNCTION**

Table 115.

Selection number	Selection name	Description
0	Coasting	The motor is allowed to stop on its own inertia. The control by the drive is discontinued and the drive current drops to zero as soon as the stop command is given.
1	Ramp	After the Stop command, the speed of the motor is decelerated according to the set deceleration parameters to zero speed.

**P3.2.6 I/O A START/STOP LOGIC**

Values 0...4 offer possibilities to control the starting and stopping of the AC drive with digital signal connected to digital inputs. CS = Control signal.

The selections including the text 'edge' shall be used to exclude the possibility of an unintentional start when, for example, power is connected, re-connected after a power failure, after a fault reset, after the drive is stopped by Run Enable (Run Enable = False) or when the control place is changed to I/O control. **The Start/Stop contact must be opened before the motor can be started.**

The used stop mode is *Coasting* in all examples.

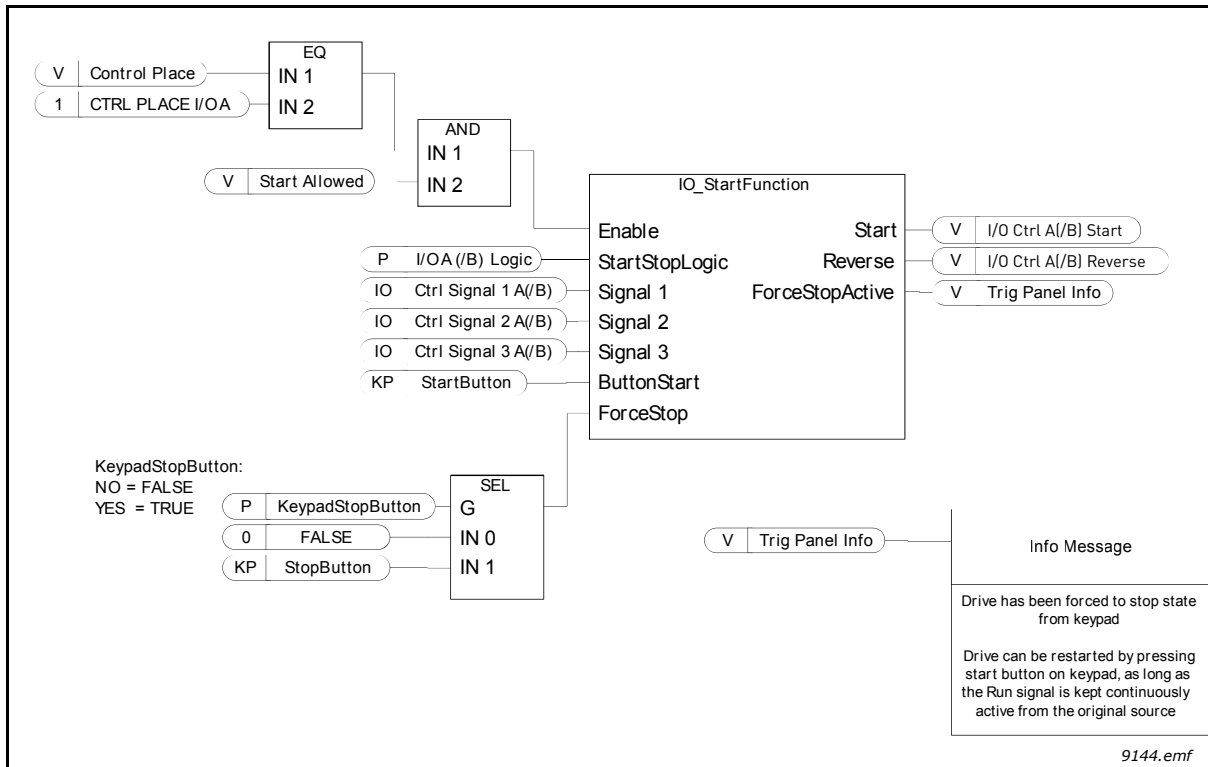

Figure 36. I/O A Start/Stop logic, block diagram

Table 116.

Selection number	Selection name	Note
0	CS1: Forward CS2: Backward	The functions take place when the contacts are closed.

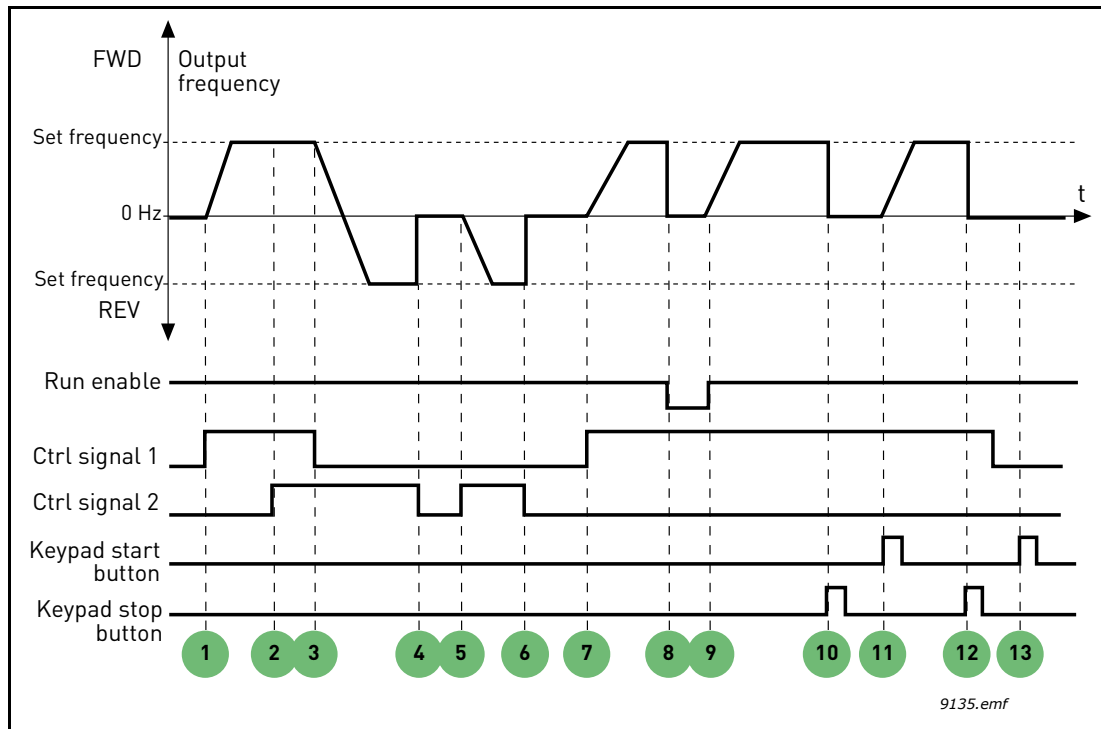

Figure 37. I/O A Start/Stop logic = 0

**Explanations:**

Table 117.

1	Control signal (CS) 1 activates causing the output frequency to rise. The motor runs forward.	8	Run enable signal is set to FALSE, which drops the frequency to 0. The run enable signal is configured with parameter P3.5.1.15.
2	CS2 activates which, however, has no effect on the output frequency because the first selected direction has the highest priority.	9	Run enable signal is set to TRUE, which causes the frequency to rise towards the set frequency because CS1 is still active.
3	CS1 is inactivated which causes the direction to start changing (FWD to REV) because CS2 is still active.	10	Keypad stop button is pressed and the frequency fed to the motor drops to 0. (This signal only works if P3.2.3 Keypad stop button = Yes)
4	CS2 inactivates and the frequency fed to the motor drops to 0.	11	The drive starts through pushing the Start button on the keypad.
5	CS2 activates again causing the motor to accelerate (REV) towards the set frequency.	12	The keypad stop button is pushed again to stop the drive.
6	CS2 inactivates and the frequency fed to the motor drops to 0.	13	The attempt to start the drive through pushing the Start button is not successful because CS1 is inactive.
7	CS1 activates and the motor accelerates (FWD) towards the set frequency		

Table 118.

Selection number	Selection name	Note
1	CS1: Forward (edge) CS2: Inverted stop CS3: Backward (edge)	For 3-wire control (pulse control)

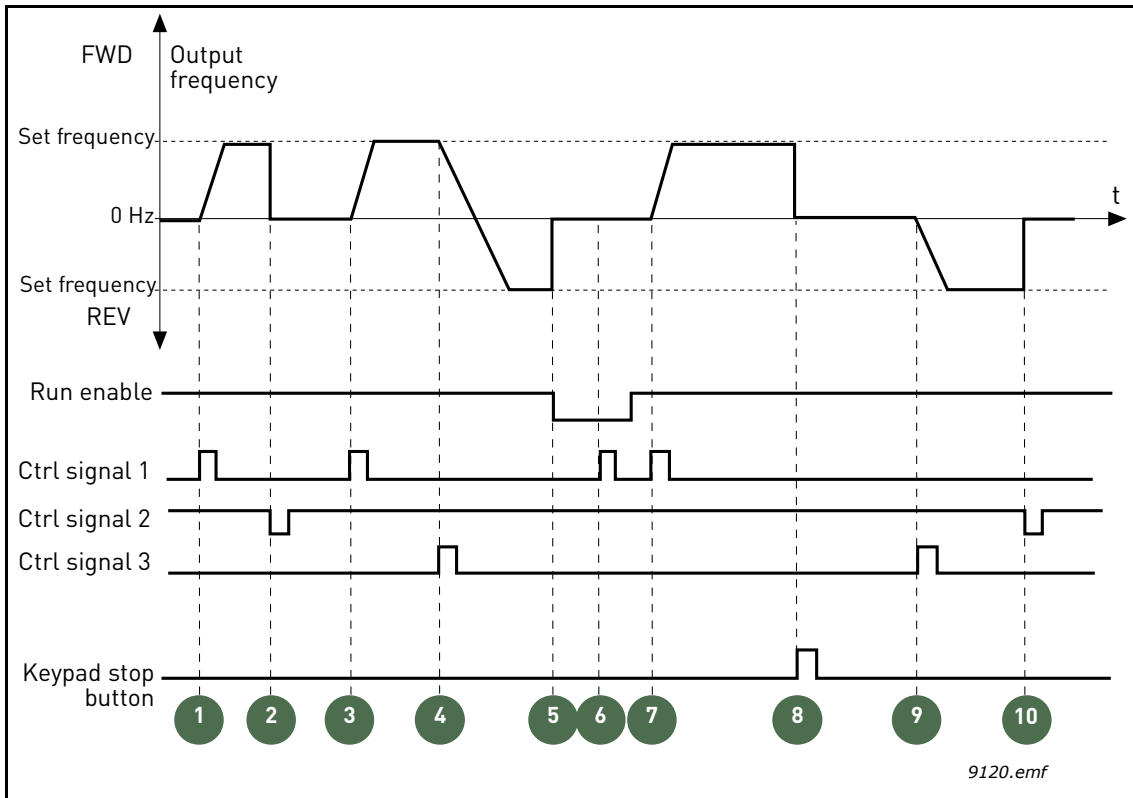

Figure 38. I/O A Start/Stop logic = 1

**Explanations:**

Table 119.

1	Control signal (CS) 1 activates causing the output frequency to rise. The motor runs forward.	6	Start attempt with CS1 is not successful because Run enable signal is still FALSE.
2	CS2 inactivates causing the frequency to drop to 0.	7	CS1 activates and the motor accelerates (FWD) towards the set frequency because the Run enable signal has been set to TRUE.
3	CS1 activates causing the output frequency to rise again. The motor runs forward.	8	Keypad stop button is pressed and the frequency fed to the motor drops to 0. (This signal only works if P3.2.3 Keypad stop button = Yes)
4	CS3 activates causing the direction to start changing (FWD to REV).	9	CS3 activates causing the motor to start and run backwards.
5	Run enable signal is set to FALSE, which drops the frequency to 0. The run enable signal is configured with parameter P3.5.1.15.	10	CS2 inactivates causing the frequency to drop to 0.

Table 120.

Selection number	Selection name	Note
2	CS1: Forward (edge) CS2: Backward (edge)	Shall be used to exclude the possibility of an unintentional start. The Start/Stop contact must be opened before the motor can be restarted.

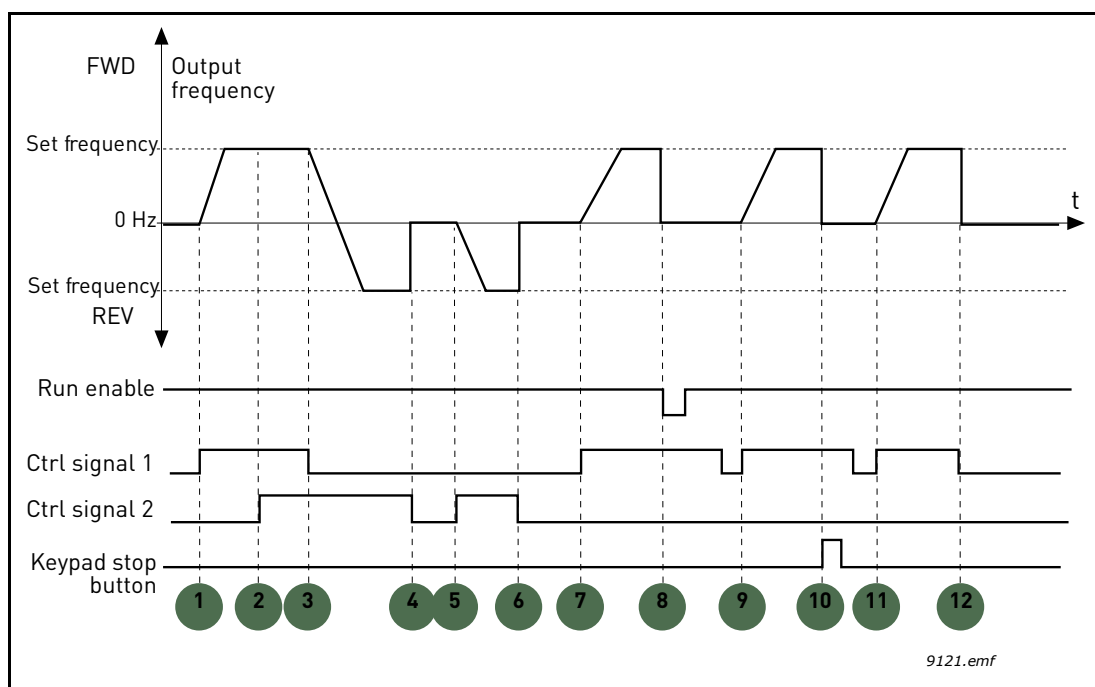

Figure 39. I/O A Start/Stop logic = 2

Explanations:

Table 121.

1	Control signal (CS) 1 activates causing the output frequency to rise. The motor runs forward.	7	CS1 activates and the motor accelerates (FWD) towards the set frequency
2	CS2 activates which, however, has no effect on the output frequency because the first selected direction has the highest priority.	8	Run enable signal is set to FALSE, which drops the frequency to 0. The run enable signal is configured with parameter P3.5.1.15.
3	CS1 is inactivated which causes the direction to start changing (FWD to REV) because CS2 is still active.	9	Run enable signal is set to TRUE, which, unlike if value 0 is selected for this parameter, has no effect because rising edge is required to start even if CS1 is active.
4	CS2 inactivates and the frequency fed to the motor drops to 0.	10	Keypad stop button is pressed and the frequency fed to the motor drops to 0. (This signal only works if P3.2.3 Keypad stop button = Yes)
5	CS2 activates again causing the motor to accelerate (REV) towards the set frequency.	11	CS1 is opened and closed again which causes the motor to start.
6	CS2 inactivates and the frequency fed to the motor drops to 0.	12	CS1 inactivates and the frequency fed to the motor drops to 0.

Table 122.

Selection number	Selection name	Note
3	CS1: Start CS2: Reverse	

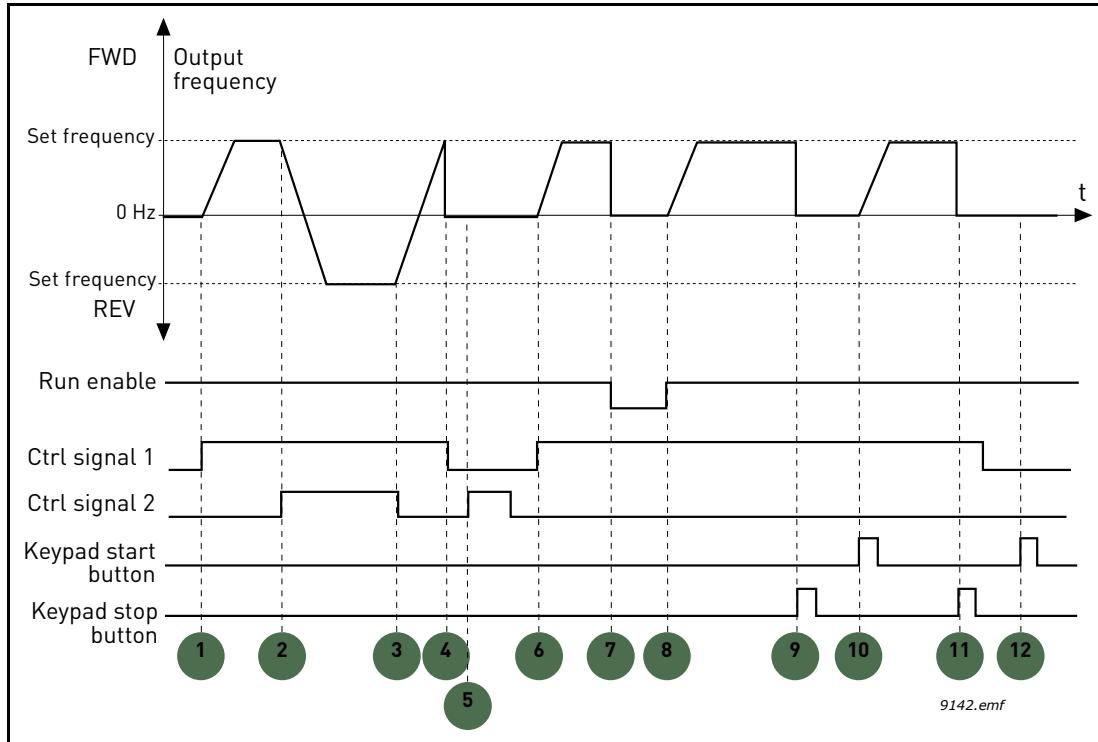

Figure 40. I/O A Start/Stop logic = 3

Table 123.

1	Control signal (CS) 1 activates causing the output frequency to rise. The motor runs forward.	7	Run enable signal is set to FALSE, which drops the frequency to 0. The run enable signal is configured with parameter P3.5.1.15.
2	CS2 activates which causes the direction to start changing (FWD to REV).	8	Run enable signal is set to TRUE, which causes the frequency to rise towards the set frequency because CS1 is still active.
3	CS2 is inactivated which causes the direction to start changing (REV to FWD) because CS1 is still active.	9	Keypad stop button is pressed and the frequency fed to the motor drops to 0. (This signal only works if P3.2.3 Keypad stop button = Yes)
4	Also CS1 inactivates and the frequency drops to 0.	10	The drive starts through pushing the Start button on the keypad.
5	Despite the activation of CS2, the motor does not start because CS1 is inactive.	11	The drive is stopped again with the stop button on the keypad.
6	CS1 activates causing the output frequency to rise again. The motor runs forward because CS2 is inactive.	12	The attempt to start the drive through pushing the Start button is not successful because CS1 is inactive.

Table 124.

Selection number	Selection name	Note
4	CS1: Start (edge) CS2: Reverse	Shall be used to exclude the possibility of an unintentional start. The Start/Stop contact must be opened before the motor can be restarted.

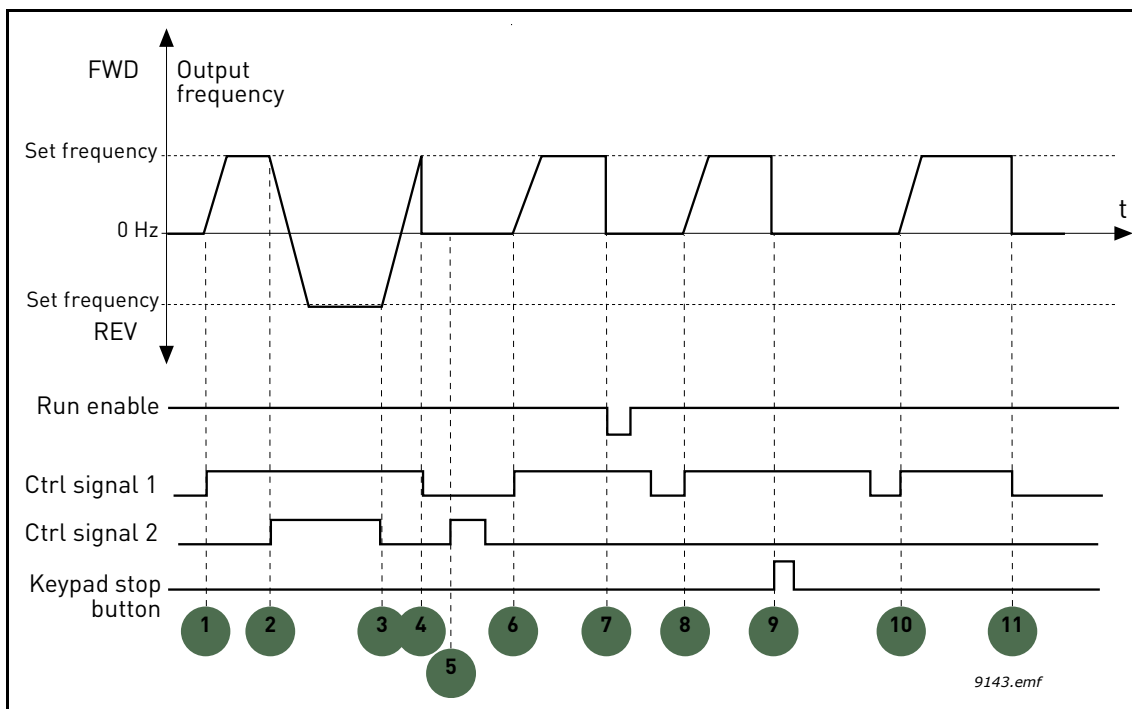

Figure 41. I/O A Start/Stop logic = 4

Table 125.

1	Control signal (CS) 1 activates causing the output frequency to rise. The motor runs forward because CS2 is inactive.	7	Run enable signal is set to FALSE, which drops the frequency to 0. The run enable signal is configured with parameter P3.5.1.15.
2	CS2 activates which causes the direction to start changing (FWD to REV).	8	Before a successful start can take place, CS1 must be opened and closed again.
3	CS2 is inactivated which causes the direction to start changing (REV to FWD) because CS1 is still active.	9	Keypad stop button is pressed and the frequency fed to the motor drops to 0. (This signal only works if P3.2.3 Keypad stop button = Yes)
4	Also CS1 inactivates and the frequency drops to 0.	10	Before a successful start can take place, CS1 must be opened and closed again.
5	Despite the activation of CS2, the motor does not start because CS1 is inactive.	11	CS1 inactivates and the frequency drops to 0.
6	CS1 activates causing the output frequency to rise again. The motor runs forward because CS2 is inactive.		



**P3.3.2.2 TORQUE MINIMUM REFERENCE**  
**P3.3.2.3 TORQUE MAXIMUM REFERENCE**

These parameters define the scaling of selected torque reference signal. For instance, the analogue input signal is scaled between the *Torque Reference Minimum* and the *Torque Reference Maximum* as shown in Figure 42.

Parameter P3.3.2.3 defines the maximum allowed torque reference for positive and negative values.

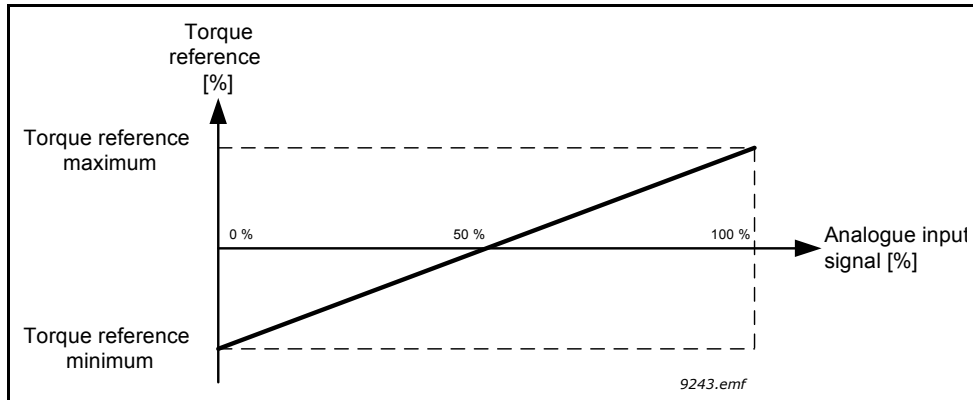

Figure 42. Torque reference signal scaling

**P3.3.3.1 PRESET FREQUENCY MODE**

You can use the preset frequency parameters to define certain frequency references in advance. These references are then applied by activating/inactivating digital inputs connected to parameters P3.3.3.10, P3.3.3.11 and P3.3.3.12 (*Preset frequency selection 0, Preset frequency selection 1 and Preset frequency selection 2*). Two different logics can be selected:

Table 126.

Selection number	Selection name	Note
0	Binary coded	Combine activated inputs according to Table 128 to choose the Preset frequency needed.
1	Number (of inputs used)	According to how many of the inputs assigned for <i>Preset frequency selections</i> are active you can apply the <i>Preset frequencies</i> 1 to 3.

**P3.3.3.2 TO P3.3.3.9 PRESET FREQUENCIES 0 TO 7**

**Value '0' selected for parameter P3.3.3.1:**

Preset frequency 0 can be chosen as reference by selecting value 1 for parameter P3.3.1.5.

Other preset frequencies 1 to 7 are selected as reference by dedicating digital inputs for parameters P3.3.3.10, P3.3.3.11 and/or P3.3.3.12. Combinations of active digital inputs determine the used preset frequency according to Table 128 below.

The values of the preset frequencies are automatically limited between the minimum and maximum frequencies (P3.3.1.1 and P3.3.1.2). See table below.

Preset frequency 0:

Table 127.

Required action	Activated frequency
Choose value 1 for parameter P3.3.1.5	Preset frequency 0

Preset frequencies 1 to 7:

Table 128. Selection of preset frequencies; ■ = input activated

Activate digital input for parameter			Activated frequency
P3.3.3.12	P3.3.3.11	P3.3.3.10	Preset frequency 1
P3.3.3.12	P3.3.3.11	P3.3.3.10	Preset frequency 2
P3.3.3.12	P3.3.3.11	P3.3.3.10	Preset frequency 3
P3.3.3.12	P3.3.3.11	P3.3.3.10	Preset frequency 4
P3.3.3.12	P3.3.3.11	P3.3.3.10	Preset frequency 5
P3.3.3.12	P3.3.3.11	P3.3.3.10	Preset frequency 6
P3.3.3.12	P3.3.3.11	P3.3.3.10	Preset frequency 7

**Value '1' selected for parameter P3.3.3.1:**

According to how many of the inputs assigned for Preset frequency selections are active, you can apply the Preset frequencies 1 to 3.

Table 129. Selection of preset frequencies; ■ = input activated

Activated input			Activated frequency
P3.3.3.12	P3.3.3.11	P3.3.3.10	Preset frequency 1
P3.3.3.12	P3.3.3.11	P3.3.3.10	Preset frequency 1
P3.3.3.12	P3.3.3.11	P3.3.3.10	Preset frequency 1
P3.3.3.12	P3.3.3.11	P3.3.3.10	Preset frequency 2
P3.3.3.12	P3.3.3.11	P3.3.3.10	Preset frequency 2
P3.3.3.12	P3.3.3.11	P3.3.3.10	Preset frequency 2
P3.3.3.12	P3.3.3.11	P3.3.3.10	Preset frequency 3

**P3.3.3.10 PRESET FREQUENCY SELECTION 0**

**P3.3.3.11 PRESET FREQUENCY SELECTION 1**

**P3.3.3.12 PRESET FREQUENCY SELECTION 2**

Connect a digital input to these functions (see chapter 3.4.13) to be able to apply Preset frequencies 1 to 7 (see Table 128 and pages 70, 78 and 143).

**P3.3.4.1 MOTOR POTENTIOMETER UP**  
**P3.3.4.2 MOTOR POTENTIOMETER DOWN**

With a motor potentiometer, the user can increase and decrease the output frequency. By connecting a digital input to parameter P3.3.4.1 (*Motor potentiometer UP*) and having the digital input signal active, the output frequency will rise as long as the signal is active. The parameter P3.3.4.2 (*Motor potentiometer DOWN*) works vice versa, decreasing the output frequency.

The rate how the output frequency either rises or falls when Motor Potentiometer Up or Down is activated is determined by the *Motor potentiometer ramp time* (P3.3.4.3) and the Ramp acceleration/deceleration times (P3.4.1.2/P3.4.1.3).

The Motor potentiometer reset parameter (P3.3.4.4) will set the frequency reference to zero if activated.

**P3.3.4.4 MOTOR POTENTIOMETER RESET**

Defines the logic for resetting the motor potentiometer frequency reference.

Selection number	Selection name	Note
0	No reset	The previous motor potentiometer frequency reference is kept past the stop state and stored to memory in case of powerdown.
1	Stop state	Motor potentiometer frequency reference is set to zero when the drive is in stop state or the drive is powered down.
2	Powered down	Motor potentiometer frequency reference is set to zero only in a powerdown situation.

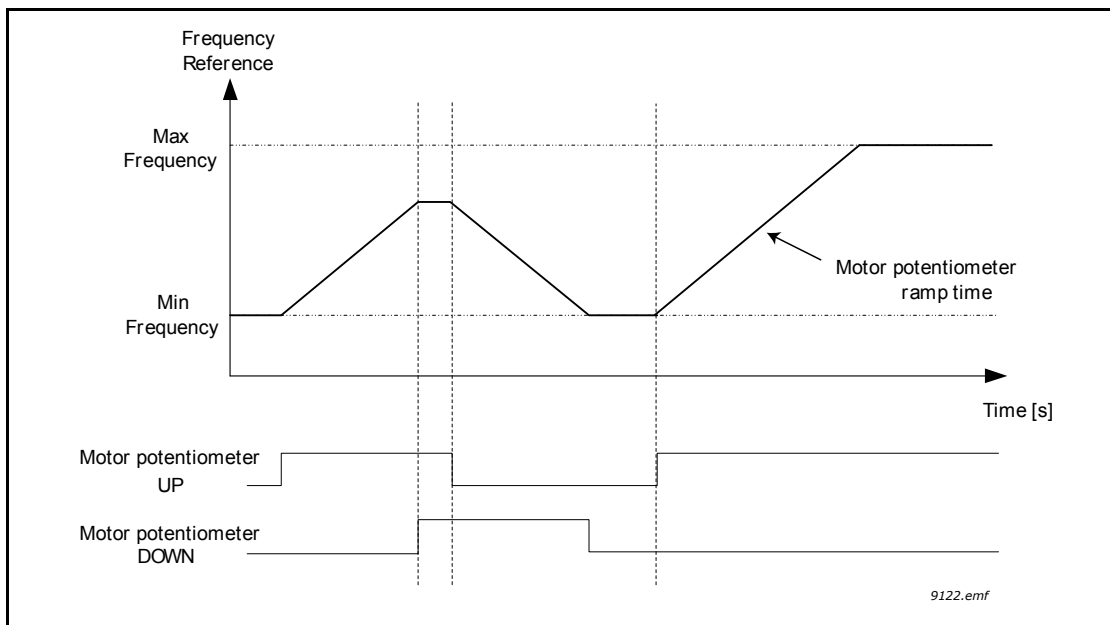

Figure 43. Motor potentiometer parameters

**P3.3.5.1 JOYSTICK SIGNAL SELECTION**

**P3.3.5.2 JOYSTICK DEAD ZONE**

**P3.3.5.3 JOYSTICK SLEEP DELAY**

When the joystick control is turned from reverse to forward, the output frequency falls linearly to the selected minimum frequency (joystick in middle position) and stays there until the joystick is turned towards the forward command. It depends on the value of *Joystick dead zone* how much the joystick must be turned to start the increase of the frequency towards the selected maximum frequency. The small values of the reference around zero can be ignored by setting this value greater than zero. When the reference is between zero to zero plus/minus this parameter, the reference is forced to zero.

If the value of parameter P3.3.5.2 is 0, the frequency starts to increase linearly immediately when the joystick/potentiometer is turned towards the forward command from the middle position. When the control is changed from forward to reverse, the frequency follows the same pattern the other way round. See 44 .

The AC drive is stopped if the joystick signal has been in the dead zone defined by P3.3.5.2 for the amount of time set with P3.3.5.3.

	<p><b>NOTE!</b> It's highly recommended to use the Joystick functions with analog inputs of the type and range -10V...+10V. If a wire breaks the input will stay at 0V which corresponds to 50% and the zero frequency reference. A range of 0 to 10V would correspond to 0% , which means that the motor would rush towards negative maximum frequency reference instead.</p>
-----------------------------------------------------------------------------------	--------------------------------------------------------------------------------------------------------------------------------------------------------------------------------------------------------------------------------------------------------------------------------------------------------------------------------------------------------------------------------

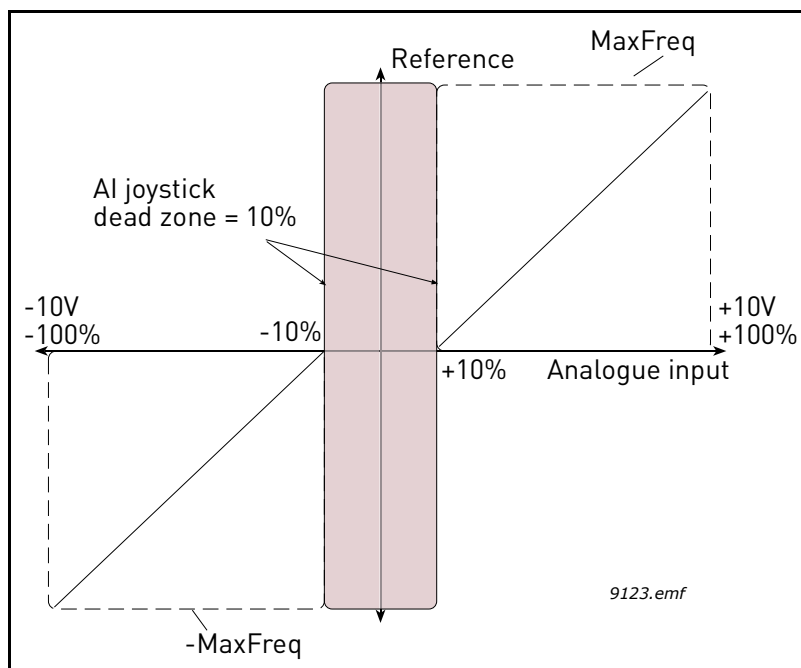

Figure 44. Joystick function

**P3.3.6.1 ENABLE DI JOGGING**

This parameter defines the digital input signal which is used to enable jogging commands from digital inputs. This signal does not affect on jogging command which are coming from Fieldbus.

**P3.3.6.2 JOGGING REFERENCE 1 ACTIVATION**  
**P3.3.6.3 JOGGING REFERENCE 2 ACTIVATION**

These parameters define the digital input signals which are used to select the frequency reference for Jogging function and force the drive to start. These digital input signals can be used only when Enable DI Jogging signal is active.

The jogging frequency references are bidirectional and the reverse command does not affect the direction of the jogging reference.

**NOTE:** The drive will start if Enable DI Jogging signal and this digital input is activated.

**NOTE:** Drive will stop if both two activation signals are active at the same time.

**P3.3.6.4 JOGGING REFERENCE 1**  
**P3.3.6.5 JOGGING REFERENCE 2**

These parameters define the frequency references for jogging function. References are bidirectional and reverse command does not affect the direction of jogging references. Reference for forward direction is defined as a positive value and reverse direction as a negative value.

Jogging function can be activated either by digital input signals or from Fieldbus in bypass mode by Control Word bits 10 and 11.

**P3.4.1.1 RAMP 1 SHAPE**  
**P3.4.2.1 RAMP 2 SHAPE**

The start and end of acceleration and deceleration ramps can be smoothed with these parameters. Setting value 0.0% gives a linear ramp shape which causes acceleration and deceleration to act immediately to the changes in the reference signal.

Setting value 1.0...100.0% for this parameter produces an S-shaped acceleration/deceleration. The acceleration time is determined with parameters P3.4.1.2 and P3.4.1.3. See 45.

These parameters are used to reduce mechanical erosion and current spikes when the reference is changed.

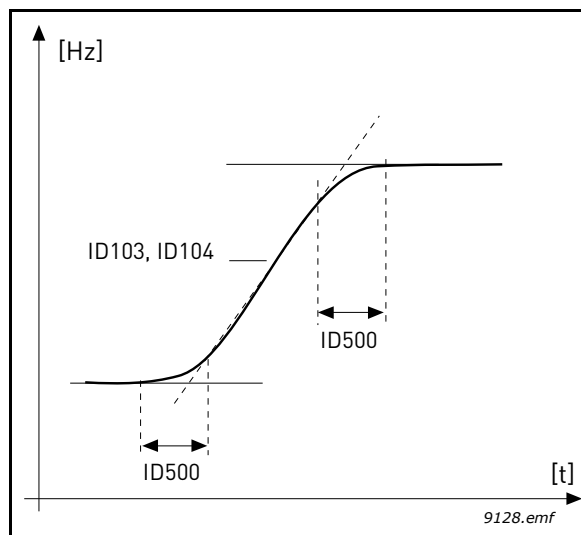

Figure 45. Acceleration/Deceleration (S-shaped)

### **P3.4.5.1 FLUX BRAKING**

Instead of DC braking, flux braking is a useful way to raise the braking capacity in cases where additional brake resistors are not needed.

When braking is needed, the frequency is reduced and the flux in the motor is increased, which in turn increases the motor's capability to brake. Unlike DC braking, the motor speed remains controlled during braking.

The flux braking can be set ON or OFF.

**NOTE:** Flux braking converts the energy into heat at the motor, and should be used intermittently to avoid motor damage.

### **P3.5.1.15 RUN ENABLE**

Contact open: Start of motor **disabled**

Contact closed: Start of motor **enabled**

The AC drive is stopped according to the selected function at P3.2.5. The follower drive will always coast to stop.

**P3.5.1.16 RUN INTERLOCK 1**  
**P3.5.1.17 RUN INTERLOCK 2**

The drive cannot be started if any of the interlocks are open.

The function could be used for a damper interlock, preventing the drive to start with damper closed.

**P3.5.2.1.2 AI1 SIGNAL FILTER TIME**

When this parameter is given a value greater than 0 the function that filters out disturbances from the incoming analogue signal is activated.

**NOTE: Long filtering time makes the regulation response slower!**

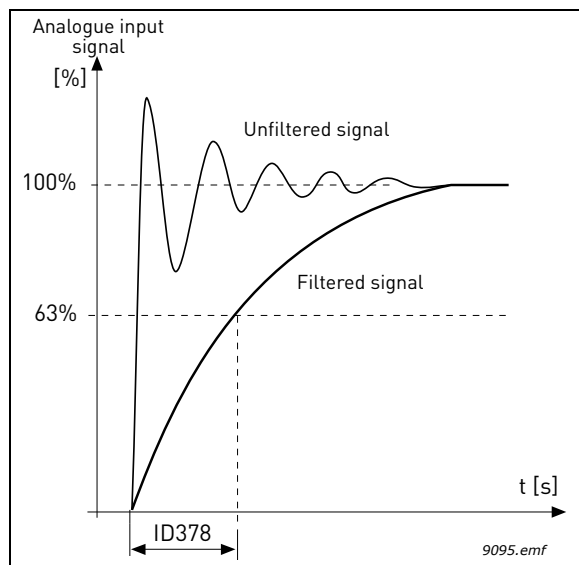

Figure 46. AI1 signal filtering

**P3.5.2.1.3 AI1 SIGNAL RANGE**

The signal range for the analogue signal can be selected as:

Type of the analogue input signal (current or voltage) is selected by the dip switches on the control board (see Installation manual).

In the following examples, the analogue input signal is used as a frequency reference. The figures show how the scaling of the analogue input signal is changed depending on the setting of this parameter.

Selection number	Selection name	Description
0	0...10 V/0...20 mA	Analogue input signal range 0...10V or 0...20mA (depending on dip switch settings on the control board). Input signal used 0...100 %.

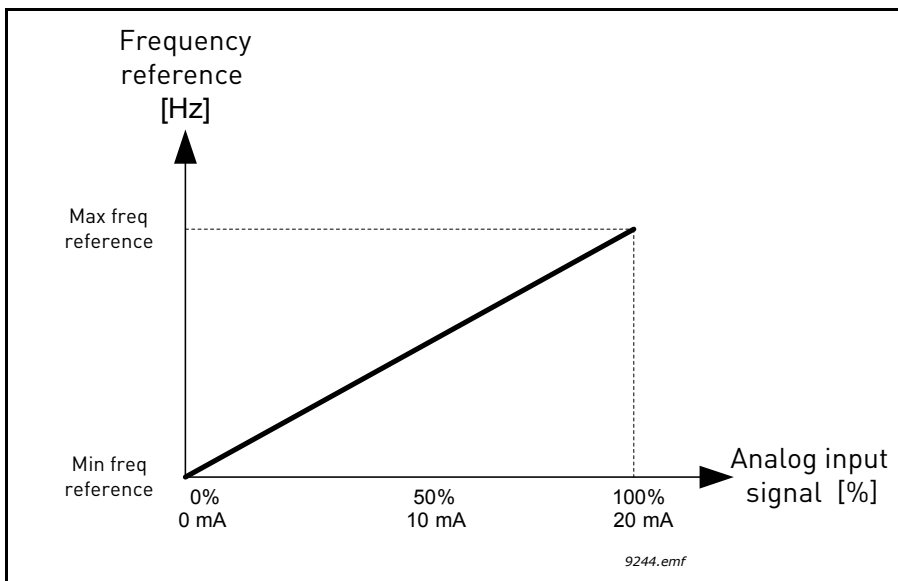

Figure 47. Analogue input signal range, selection '0'

Selection number	Selection name	Description
1	2...10 V/4...20 mA	Analogue input signal range 2...10V or 4...20mA (depending on dip switch settings on the control board). Input signal used 20...100 %.

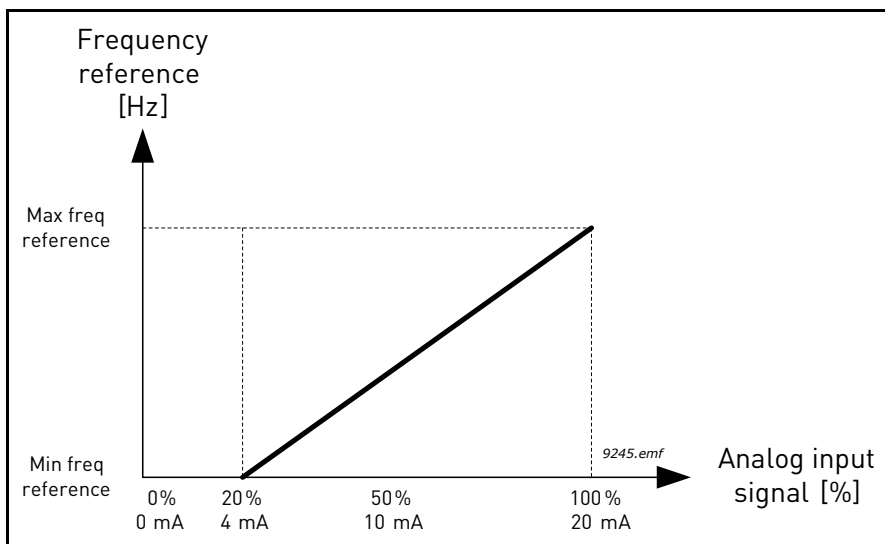

Figure 48. Analogue input signal range, selection '1'

**P3.5.2.1.4 AI1 CUSTOM. MIN**  
**P3.5.2.1.5 AI1 CUSTOM. MAX**

These parameters allow you to freely adjust the analogue input signal range between -160...160%.

**Example:** If the analogue input signal is used as frequency reference and these parameters are set to 40...80%, the frequency reference is changed between the Minimum frequency reference and the Maximum frequency reference when the analogue input signal is changed between 8...16 mA.



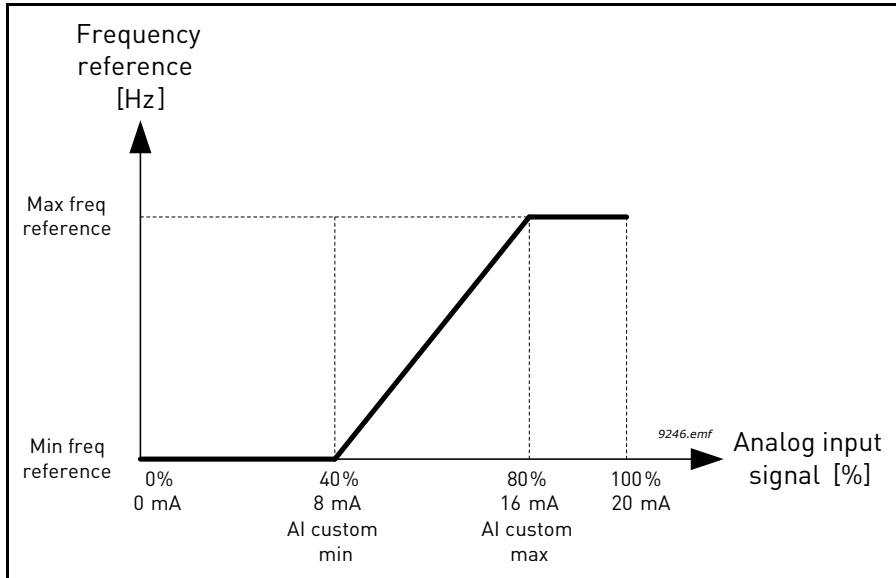

Figure 49. AI signal custom min/max

**P3.5.2.1.6 AI1 SIGNAL INVERSION**

Invert the analogue signal with this parameter.

In the following examples, the analogue input signal is used as frequency reference. The figures show how the scaling of the analogue input signal is changed depending on the setting of this parameter.

Selection number	Selection name	Description
0	Normal	No inversion. The analogue input signal value 0% corresponds to the Minimum frequency reference and the analogue input signal value 100% to the Maximum frequency reference.

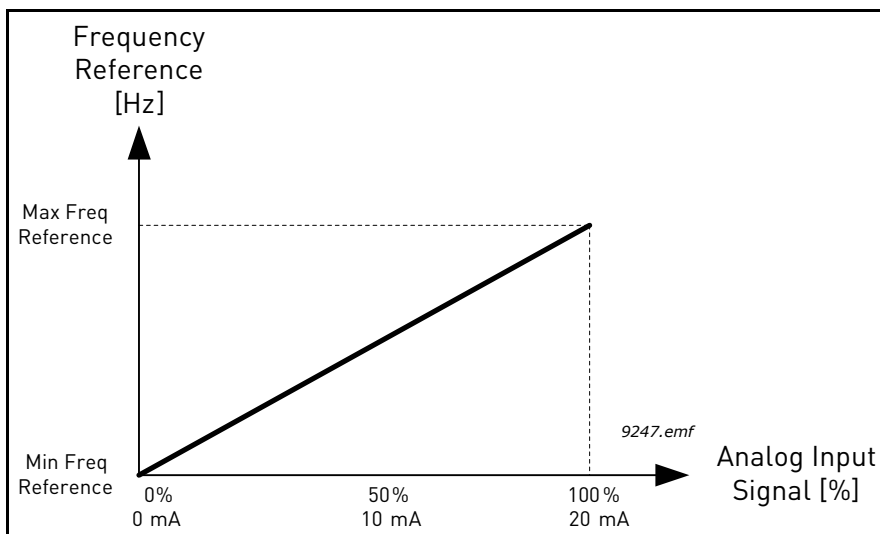

Figure 50. AI signal inversion, selection '0'

Selection number	Selection name	Description
1	Inverted	Signal inverted. The analogue input signal value 0% corresponds to the Maximum frequency reference and the analogue input signal value 100% to the Minimum frequency reference.

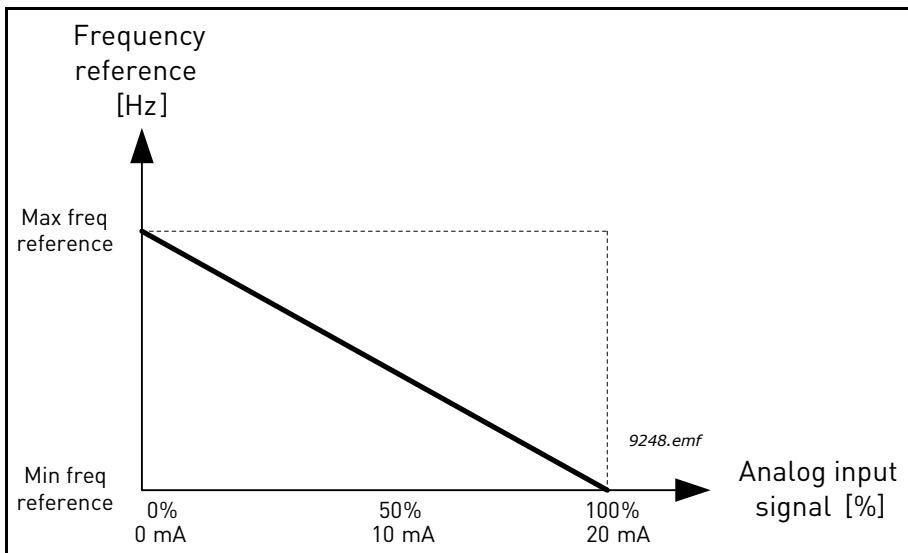

Figure 51. AI signal inversion, selection '1'

**P3.5.3.2.1 BASIC RO1 FUNCTION**

Table 130. Output signals via RO1

Selection	Selection name	Description
0	Not used	Output not used
1	Ready	The AC drive is ready to operate
2	Run	The AC drive operates (motor is running)
3	General fault	A fault trip has occurred
4	General fault inverted	A fault trip has <b>not</b> occurred
5	General alarm	An alarm has been initiated
6	Reversed	The reverse command has been given
7	At speed	The output frequency has reached the set frequency reference
8	Thermistor fault	A thermistor fault has occurred.
9	Motor regulator activated	One of the limit regulators (e.g. current limit, torque limit) is activated
10	Start signal active	Drive start command is active.
11	Keypad control active	Keypad control selected (active control place is keypad).
12	I/O control B active	I/O control place B selected (active control place is I/O B)

Table 130. Output signals via RO1

Selection	Selection name	Description
13	Limit supervision 1	Activates if the signal value falls below or exceeds the set supervision limit (P3.8.3 or P3.8.7) depending on the selected function.
14	Limit supervision 2	
15	Fire Mode active	Fire Mode function is active.
16	Jogging active	Jogging function is active.
17	Preset Frequency active	The preset frequency has been selected with digital input signals.
18	Quick Stop active	Quick Stop function has been activated.
19	PID in Sleep mode	PID-controller is in Sleep mode.
20	PID Soft Fill activated	PID-controller Soft Fill function is activated.
21	PID feedback supervision	PID-controller feedback value is beyond the supervision limits. See chapter 3.4.26.6.
22	ExtPID feedback supervision	External PID-controller feedback value is beyond the supervision limits. See chapter 3.4.27.4.
23	Input pressure alarm	The input pressure signal value of the pump has fallen below the value defined with parameter P3.13.9.7. See chapter 3.4.26.9.
24	Frost protection alarm	The pump's measured temperature has fallen below the level defined with parameter P3.13.10.5. See chapter 3.4.26.10.
25	Motor 1 control	Contact control for <i>Multi-pump</i> function
26	Motor 2 control	Contact control for <i>Multi-pump</i> function
27	Motor 3 control	Contact control for <i>Multi-pump</i> function
28	Motor 4 control	Contact control for <i>Multi-pump</i> function
29	Motor 5 control	Contact control for <i>Multi-pump</i> function
30	Motor 6 control	Contact control for <i>Multi-pump</i> function
31	Time channel 1	Status of Time channel 1
32	Time channel 2	Status of Time channel 2
33	Time channel 3	Status of Time channel 3
34	Fieldbus Control Word bit 13	Digital (relay) output control from Fieldbus control word bit 13.
35	Fieldbus Control Word bit 14	Digital (relay) output control from Fieldbus control word bit 14.
36	Fieldbus Control Word bit 15	Digital (relay) output control from Fieldbus control word bit 15.
37	Fieldbus Process Data In1 bit 0	Digital (relay) output control from Fieldbus Process Data In1, bit 0.
38	Fieldbus Process Data In1 bit 1	Digital (relay) output control from Fieldbus Process Data In1, bit 1.
39	Fieldbus Process Data In1 bit 2	Digital (relay) output control from Fieldbus Process Data In1, bit 2.
40	Maintenance counter 1 alarm	Maintenance counter has reached the alarm limit defined with parameter P3.16.2. See chapter 3.4.29.
41	Maintenance Counter 1 Fault	Maintenance counter has reached the alarm limit defined with parameter P3.16.3. See chapter 3.4.29.

Table 130. Output signals via RO1

Selection	Selection name	Description
42	Mechanical brake control	'Open Mechanical Brake' -command. See chapter 3.4.32.
43	Mechanical brake control (Inverted)	'Open Mechanical Brake' -command (inverted). See chapter 3.4.32.
44	Block 1 Out	Output of programmable Block 1. See parameter menu M3.19 Block Programming.
45	Block 2 Out	Output of programmable Block 2. See parameter menu M3.19 Block Programming.
46	Block 3 Out	Output of programmable Block 3. See parameter menu M3.19 Block Programming.
47	Block 4 Out	Output of programmable Block 4. See parameter menu M3.19 Block Programming.
48	Block 5 Out	Output of programmable Block 5. See parameter menu M3.19 Block Programming.
49	Block 6 Out	Output of programmable Block 6. See parameter menu M3.19 Block Programming.
50	Block 7 Out	Output of programmable Block 7. See parameter menu M3.19 Block Programming.
51	Block 8 Out	Output of programmable Block 8. See parameter menu M3.19 Block Programming.
52	Block 9 Out	Output of programmable Block 9. See parameter menu M3.19 Block Programming.
53	Block 10 Out	Output of programmable Block 10. See parameter menu M3.19 Block Programming.
54	Jockey pump control	Control signal for external jockey pump. See chapter 3.4.33.2.
55	Priming pump control	Control signal for external priming pump. See chapter 3.4.33.3.
56	Auto-cleaning active	Pump auto-cleaning function is activated.

### P3.5.4.1.1 AO1 FUNCTION

This parameter defines the content of the analogue output signal 1. The scaling of the analogue output signal depends on the selected signal. See Table 131.

Table 131. AO1 signal scaling

Selection	Selection name	Description
0	Test 0% (Not used)	Analogue output is forced either to 0% or 20% depending on parameter P3.5.4.1.3.
1	TEST 100%	Analogue output is forced to 100% signal (10V / 20mA).
2	Output frequency	Actual output frequency from zero to Maximum frequency reference.
3	Frequency reference	Actual frequency reference from zero to Maximum frequency reference.
4	Motor speed	Actual motor speed from zero to Motor nominal speed.
5	Output current	Drive output current from zero to Motor nominal current.

Table 131. AO1 signal scaling

Selection	Selection name	Description
6	Motor torque	Actual motor torque from zero to motor nominal torque (100%).
7	Motor power	Actual motor power from zero to Motor nominal power (100%).
8	Motor voltage	Actual motor voltage from zero to Motor nominal voltage.
9	DC-link voltage	Actual DC-link voltage 0...1000V.
10	PID Setpoint	PID Controller actual setpoint value (0...100%).
11	PID Feedback	PID Controller actual feedback value (0...100%).
12	PID output	PID controller output (0...100%).
13	ExtPID output	External PID controller output (0...100%).
14	Fieldbus Process Data In 1	Fieldbus Process Data In 1 from 0...10000 (corresponding 0...100.00%).
15	Fieldbus Process Data In 2	Fieldbus Process Data In 2 from 0...10000 (corresponding 0...100.00%).
16	Fieldbus Process Data In 3	Fieldbus Process Data In 3 from 0...10000 (corresponding 0...100.00%).
17	Fieldbus Process Data In 4	Fieldbus Process Data In 4 from 0...10000 (corresponding 0...100.00%).
18	Fieldbus Process Data In 5	Fieldbus Process Data In 5 from 0...10000 (corresponding 0...100.00%).
19	Fieldbus Process Data In 6	Fieldbus Process Data In 6 from 0...10000 (corresponding 0...100.00%).
20	Fieldbus Process Data In 7	Fieldbus Process Data In 7 from 0...10000 (corresponding 0...100.00%).
21	Fieldbus Process Data In 8	Fieldbus Process Data In 8 from 0...10000 (corresponding 0...100.00%).
22	Block 1 Out	Output of programmable Block 1 from 0...10000 (corresponding 0...100,00%). See parameter menu M3.19 Block Programming.
23	Block 2 Out	Output of programmable Block 2 from 0...10000 (corresponding 0...100,00%). See parameter menu M3.19 Block Programming.
24	Block 3 Out	Output of programmable Block 3 from 0...10000 (corresponding 0...100,00%). See parameter menu M3.19 Block Programming.
25	Block 4 Out	Output of programmable Block 4 from 0...10000 (corresponding 0...100,00%). See parameter menu M3.19 Block Programming.
26	Block 5 Out	Output of programmable Block 5 from 0...10000 (corresponding 0...100,00%). See parameter menu M3.19 Block Programming.
27	Block 6 Out	Output of programmable Block 6 from 0...10000 (corresponding 0...100,00%). See parameter menu M3.19 Block Programming.
28	Block 7 Out	Output of programmable Block 7 from 0...10000 (corresponding 0...100,00%). See parameter menu M3.19 Block Programming.

Table 131. AO1 signal scaling

Selection	Selection name	Description
29	Block 8 Out	Output of programmable Block 8 from 0...10000 (corresponding 0...100,00%). See parameter menu M3.19 Block Programming
30	Block 9 Out	Output of programmable Block 9 from 0...10000 (corresponding 0...100,00%). See parameter menu M3.19 Block Programming
31	Block 10 Out	Output of programmable Block 10 from 0...10000 (corresponding 0...100,00%). See parameter menu M3.19 Block Programming

**P3.5.4.1.4 AO1 MINIMUM SCALE**

**P3.5.4.1.5 AO1 MAXIMUM SCALE**

These parameters can be used to freely adjust the analogue output signal scaling. The scale is defined in process units and it depends on the selection of parameter P3.5.4.1.1.

**Example:** The drive's output frequency is selected for the content of the analogue output signal and parameters P3.5.4.1.4 and P3.5.4.1.5 are set to 10...40 Hz.

When the drive's output frequency changes between 10 and 40 Hz the analogue output signal changes between 0...20 mA.

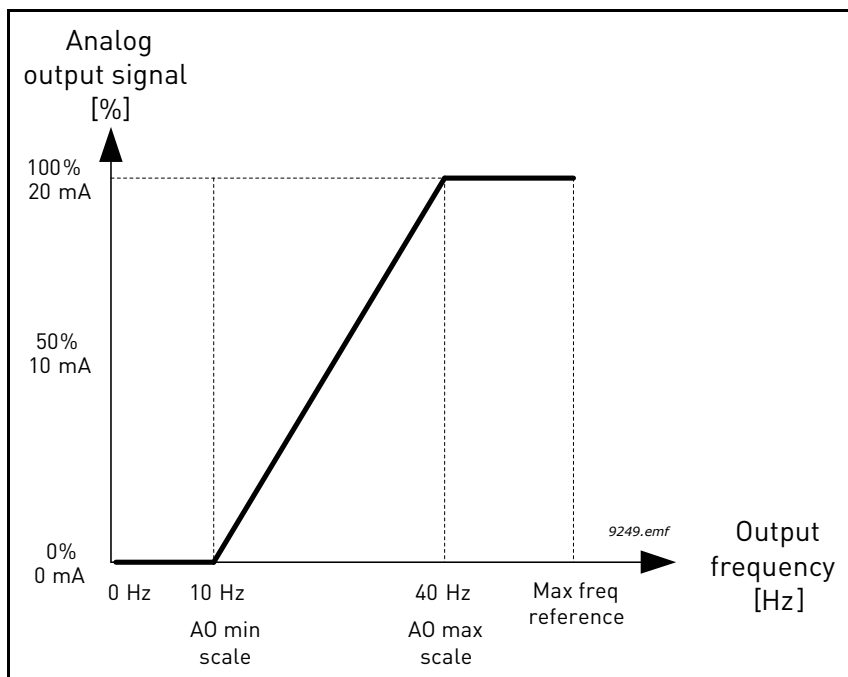

Figure 52. AO1 signal scaling

- P3.7.1**      **PROHIBIT FREQUENCY RANGE 1 LOW LIMIT**
- P3.7.2**      **PROHIBIT FREQUENCY RANGE 1 HIGH LIMIT**
- P3.7.3**      **PROHIBIT FREQUENCY RANGE 2 LOW LIMIT**
- P3.7.4**      **PROHIBIT FREQUENCY RANGE 2 HIGH LIMIT**
- P3.7.5**      **PROHIBIT FREQUENCY RANGE 3 LOW LIMIT**
- P3.7.6**      **PROHIBIT FREQUENCY RANGE 3 HIGH LIMIT**

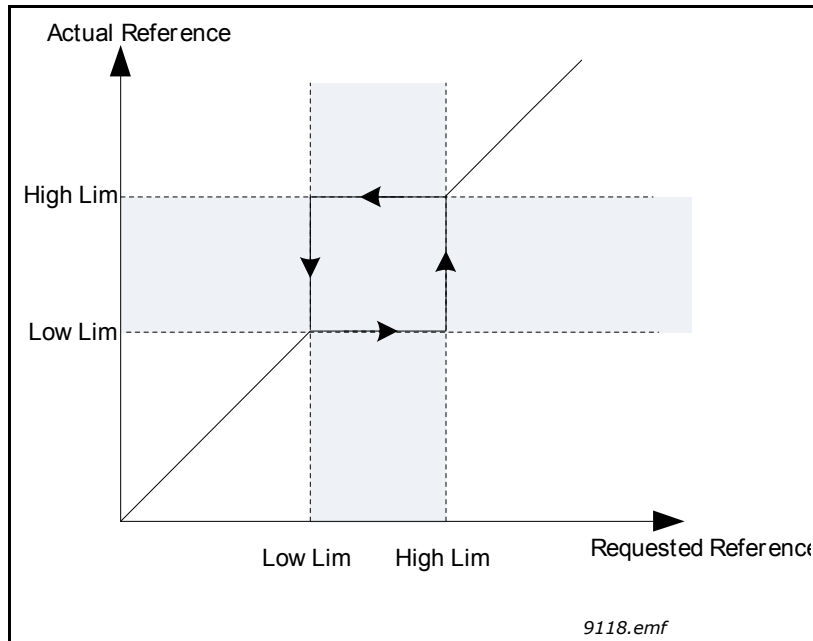

Figure 53. Prohibited frequencies

**P3.7.7**      **RAMP TIME FACTOR**

The *Ramp time factor* defines the acceleration/deceleration time when the output frequency is in a prohibited frequency range. The *Ramp time factor* is multiplied with the value of parameters P3.4.1.2/P3.4.1.3 (*Ramp acceleration/deceleration time*). For example the value 0.1 makes the acceleration/deceleration time ten times shorter.

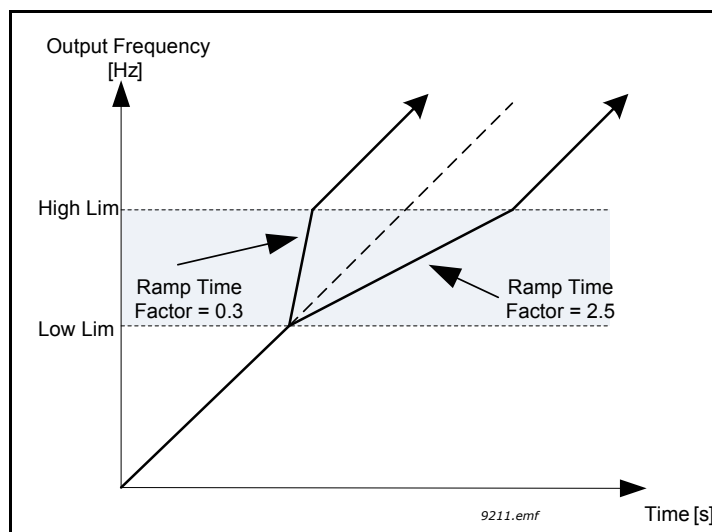

Figure 54. Ramp time factor

**P3.9.1.2 RESPONSE TO EXTERNAL FAULT**

An alarm message or a fault action and message is generated by an external fault external fault signal in one of the programmable digital inputs (DI3 by default) using parameters P3.5.1.11 and P3.5.1.12. The information can also be programmed into any of the relay outputs.

**P3.9.2.3 ZERO SPEED COOLING FACTOR**

Defines the cooling factor at zero speed in relation to the point where the motor is running at nominal speed without external cooling. See 55.

The default value is set assuming that there is no external fan cooling the motor. If an external fan is used this parameter can be set to 90% (or even higher).

If you change the parameter P3.1.1.4 (*Motor nominal current*), this parameter is automatically restored to the default value.

Setting this parameter does not affect the maximum output current of the drive which is determined by parameter P3.1.3.1 alone.

The corner frequency for the thermal protection is 70% of the motor nominal frequency (P3.1.1.2).

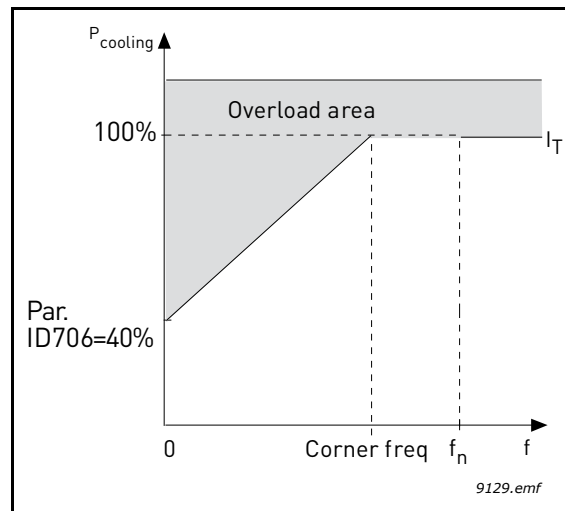

Figure 55. Motor thermal current  $I_T$  curve

**P3.9.2.4 MOTOR THERMAL TIME CONSTANT**

This is the thermal time constant of the motor. The bigger the motor, the bigger the time constant. The time constant is the time within which the calculated thermal stage has reached 63% of its final value.

The motor thermal time is specific to the motor design and it varies between different motor manufacturers. The default value of the parameter varies from size to size.

If the motor's t6-time (t6 is the time in seconds the motor can safely operate at six times the rated current) is known (given by the motor manufacturer) the time constant parameter can be set basing on it. As a rule of thumb, the motor thermal time constant in minutes equals to 2\*t6. If the drive is in stop stage the time constant is internally increased to three times the set parameter value. The cooling in stop stage is based on convection and the time constant is increased.

See 57.



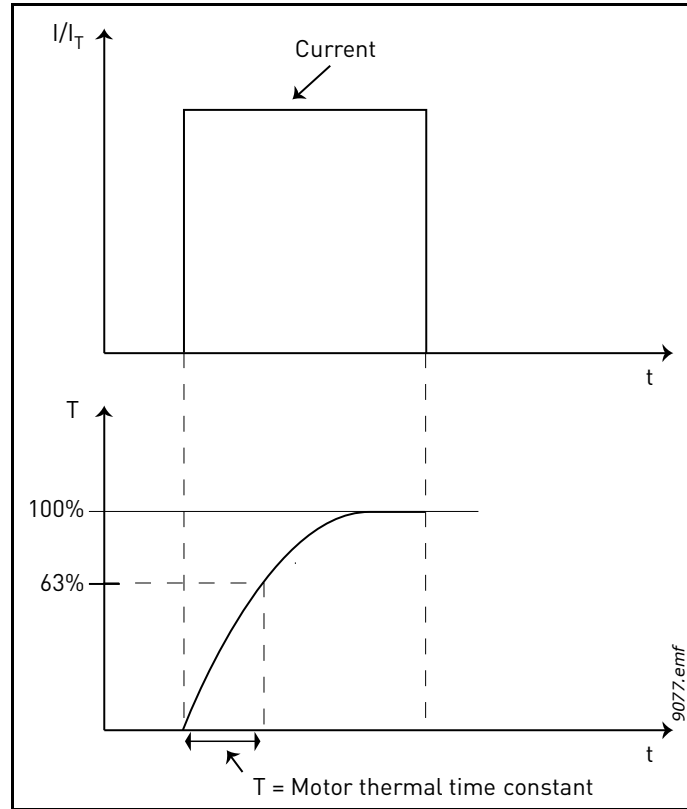

Figure 56. Motor thermal time constant

**P3.9.2.5 MOTOR THERMAL LOADABILITY**

Setting value to 130% means that the nominal temperature will be reached with 130% of motor nominal current.

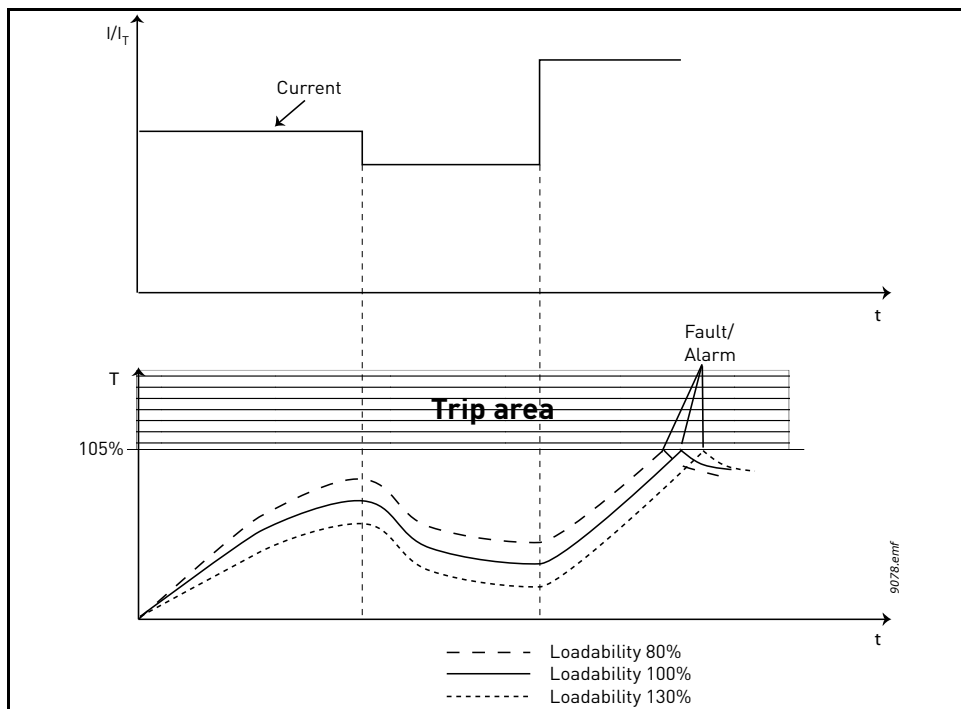

Figure 57. Motor temperature calculation

**P3.9.3.2 STALL CURRENT**

The current can be set to  $0.0...2 \cdot I_L$ . For a stall stage to occur, the current must have exceeded this limit. See 58. If parameter P3.1.3.1 *Motor current limit* is changed, this parameter is automatically calculated to 90% of the current limit. See page 91.

**NOTE!** In order to guarantee desired operation, this limit must be set below the current limit.

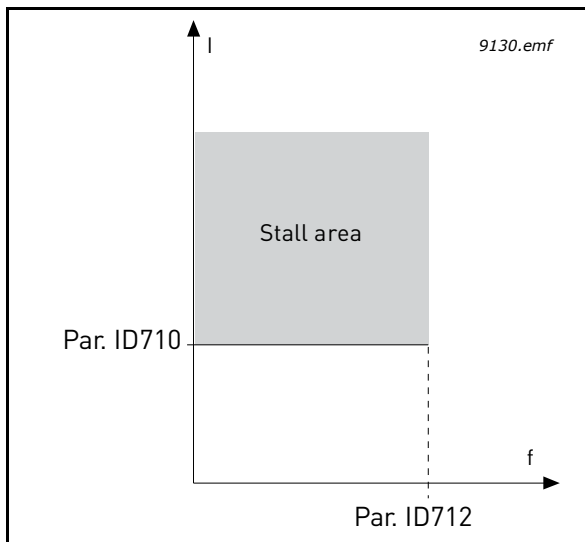

Figure 58. Stall characteristics settings

**P3.9.3.3 STALL TIME LIMIT**

This time can be set between 1.0 and 120.0s.

This is the maximum time allowed for a stall stage. The stall time is counted by an internal up/down counter.

If the stall time counter value goes above this limit the protection will cause a trip (see P3.9.3.1). See page 91.

**P3.9.4.2 UNDERLOAD PROTECTION: FIELD WEAKENING AREA LOAD**

The torque limit can be set between 10.0-150.0 %  $\times T_{nMotor}$ .

This parameter gives the value for the minimum torque allowed when the output frequency is above the field weakening point. See 59.

If you change parameter P3.1.1.4 (*Motor nominal current*) this parameter is automatically restored to the default value. See page 92.

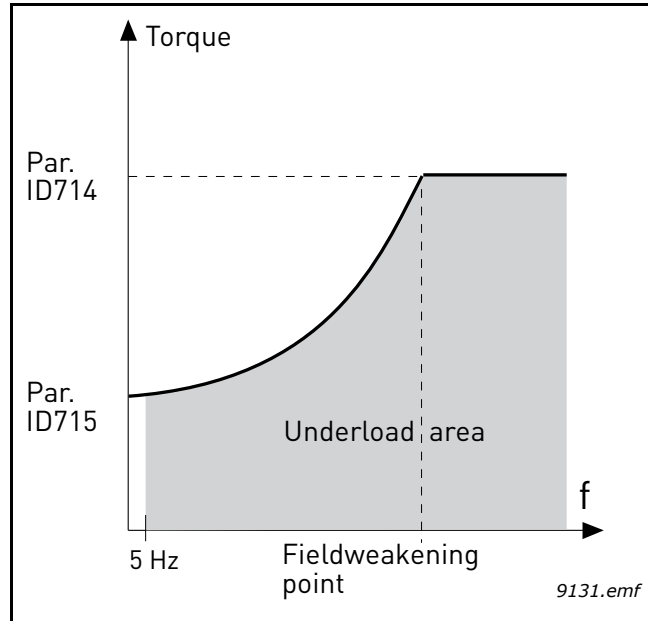

Figure 59. Setting of minimum load

**P3.9.4.4 UNDERLOAD PROTECTION: TIME LIMIT**

This time can be set between 2.0 and 600.0 s.

This is the maximum time allowed for an underload state to exist. An internal up/down counter counts the accumulated underload time. If the underload counter value goes above this limit the protection will cause a trip according to parameter P3.9.4.1). If the drive is stopped the underload counter is reset to zero. See 60 and page 92.

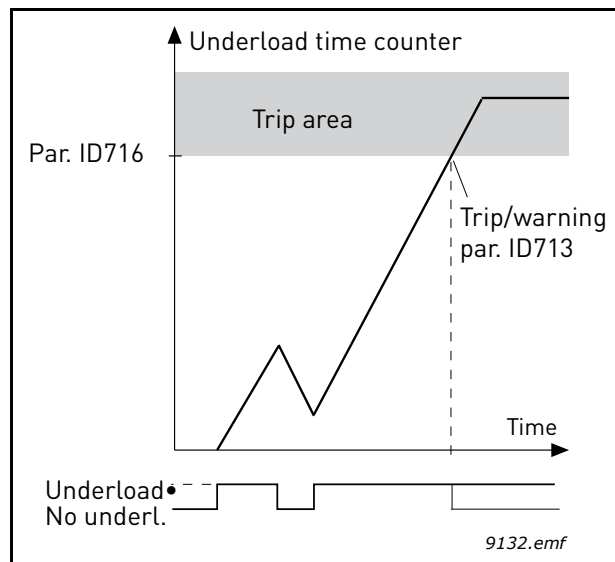

Figure 60. Underload time counter function

**P3.9.5.1 QUICK STOP MODE**  
**P3.5.1.26 QUICK STOP ACTIVATION**  
**P3.9.5.3 QUICK STOP DECELERATION TIME**  
**P3.9.5.4 RESPONSE TO QUICK STOP FAULT**

The *Quick stop* function is a way to stop the drive in an exceptional manner from I/O or Fieldbus in an exceptional situation. The drive can be made to decelerate and stop according to separately defined method when the *Quick stop* is activated. An alarm or fault response, depending if a reset is required for restart, can also be set to leave a mark that a quick stop has been requested in the fault history.

**NOTE!** *Quick stop* is not an emergency stop or safety function! It is advised that an emergency stop physically cuts the power supply to the motor.

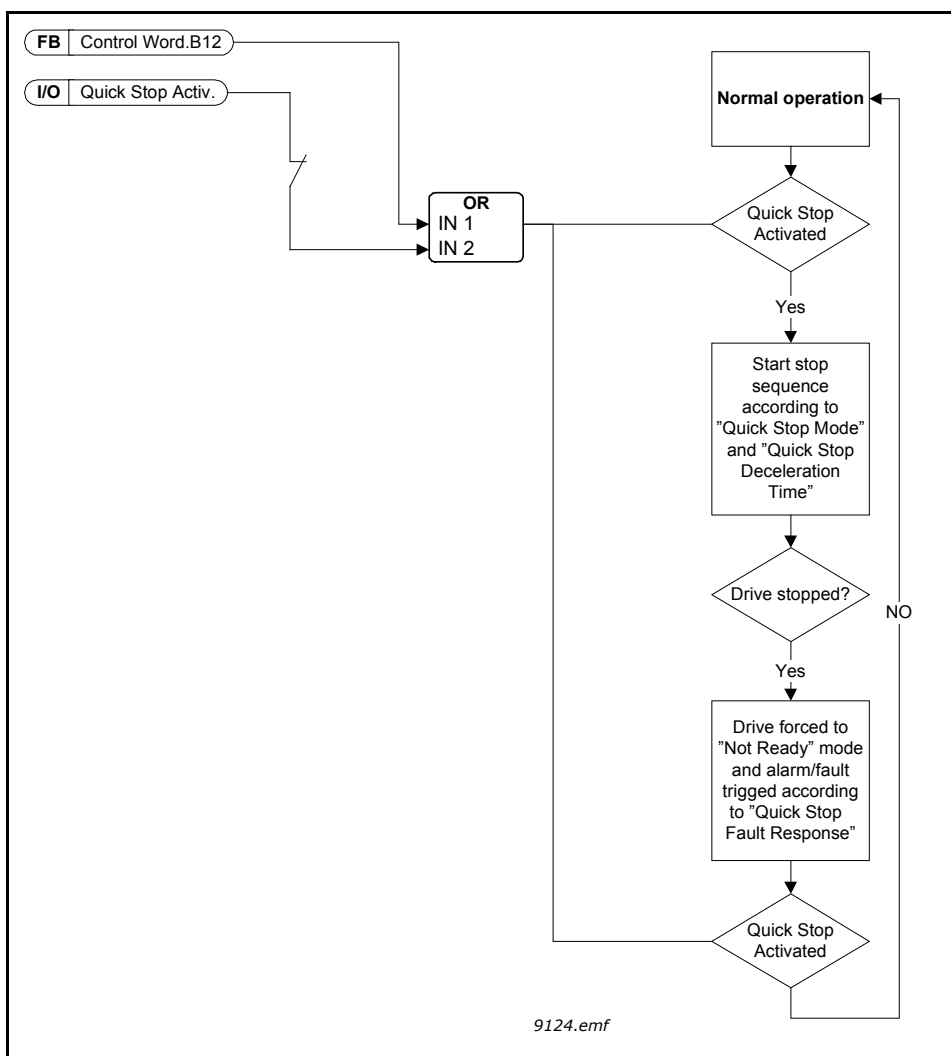

Figure 61. Quick stop logic

**P3.9.8.1 ANALOQUE INPUT LOW PROTECTION**

This parameter defines if the AI Low Protection is used or not.

AI Low protection is used to detect analog input signal failures if the input signal used as frequency reference or torque reference or PID/ExtPID controllers are configured to use analog input signals.

The user can select if the protection is enabled only when the drive is in Run state or respectively in both Run and Stop states. Response for the AI Low Fault can be selected by parameter P3.9.8.2 AI Low Fault.

Table 132. AI low protection settings

Selection number	Selection name	Description
1	Protection disabled	
2	Protection enabled in Run state	The protection is enabled only when the drive is in run state
3	Protection enabled in Run and Stop	Protection is enabled in both, run and stop states

**P3.9.8.2 ANALOQUE INPUT LOW FAULT**

This parameter defines the response for F50 - AI Low Fault (Fault ID: 1050) if AI Low Protection is enabled by parameter 3.9.8.1.

AI Low protection monitors the signal level of analogue inputs 1-6. AI Low fault or alarm is generated if parameter P3.9.8.1 AI Low Protection is Enabled and analogue input signal falls below 50% of the defined minimum signal range for 3 seconds.

Table 133.

Selection number	Selection name	Description
1	Alarm	
2	Alarm	P3.9.1.13 is set to frequency reference
3	Alarm	The last valid frequency is kept as frequency reference
4	Fault	Stop according to Stop mode P3.2.5
5	Fault	Stop by coasting

**NOTE:** AI Low Fault response 3 (Alarm + Previous Freq) can be used only if analog input 1 or analog input 2 is used as frequency reference.

**P3.10.1 AUTOMATIC RESET**

Activate the *Automatic reset* after fault with this parameter.

**NOTE:** Automatic reset is allowed for certain faults only. By giving the parameters P3.10.6 to P3.10.13 the value **0** or **1** you can either allow or deny the automatic reset after the respective faults.

**P3.10.3 WAIT TIME**  
**P3.10.4 AUTOMATIC RESET: TRIAL TIME**  
**P3.10.5 NUMBER OF TRIALS**

The Automatic reset function keeps resetting the faults appearing during the time set with this parameter. If the number of faults during the trial time exceed the value of parameter P3.10.5 a permanent fault is generated. Otherwise the fault is cleared after the trial time has elapsed and the next fault starts the trial time count again.

Parameter P3.10.5 determines the maximum number of automatic fault reset attempts during the trial time set by this parameter. The time count starts from the first autoreset. The maximum number is independent of the fault type.

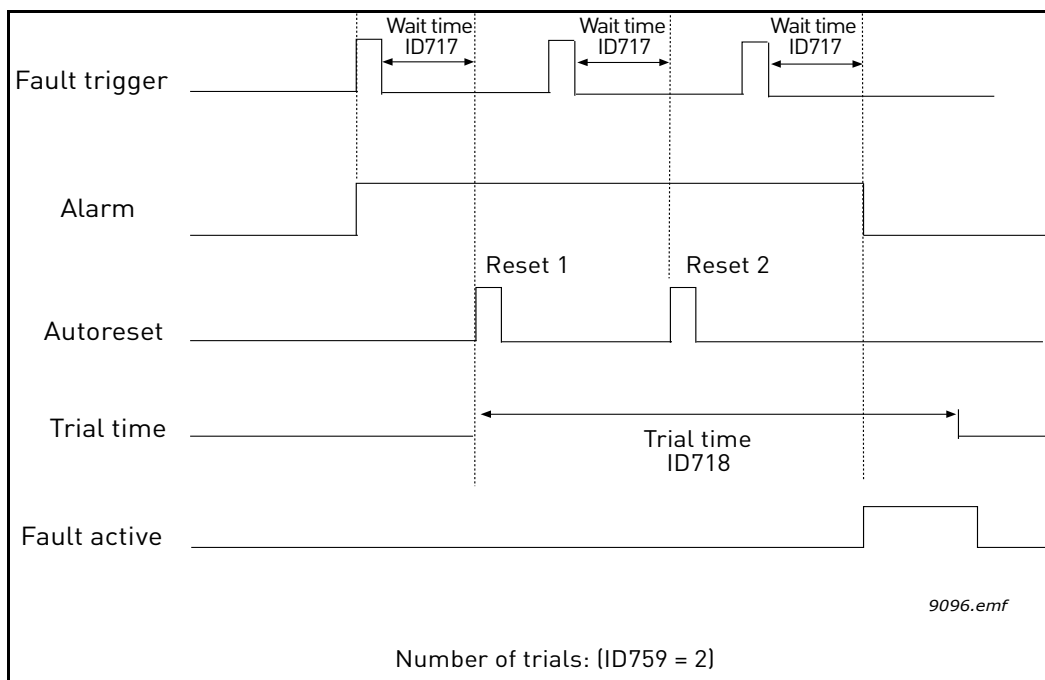

Figure 62. Automatic reset function

**P3.13.1.9 DEAD BAND**  
**P3.13.1.10 DEAD BAND DELAY**

The PID controller output is locked if the actual value stays within the deadband area around the reference for a predefined time. This function will prevent unnecessary movement and wear on actuators, e.g. valves.

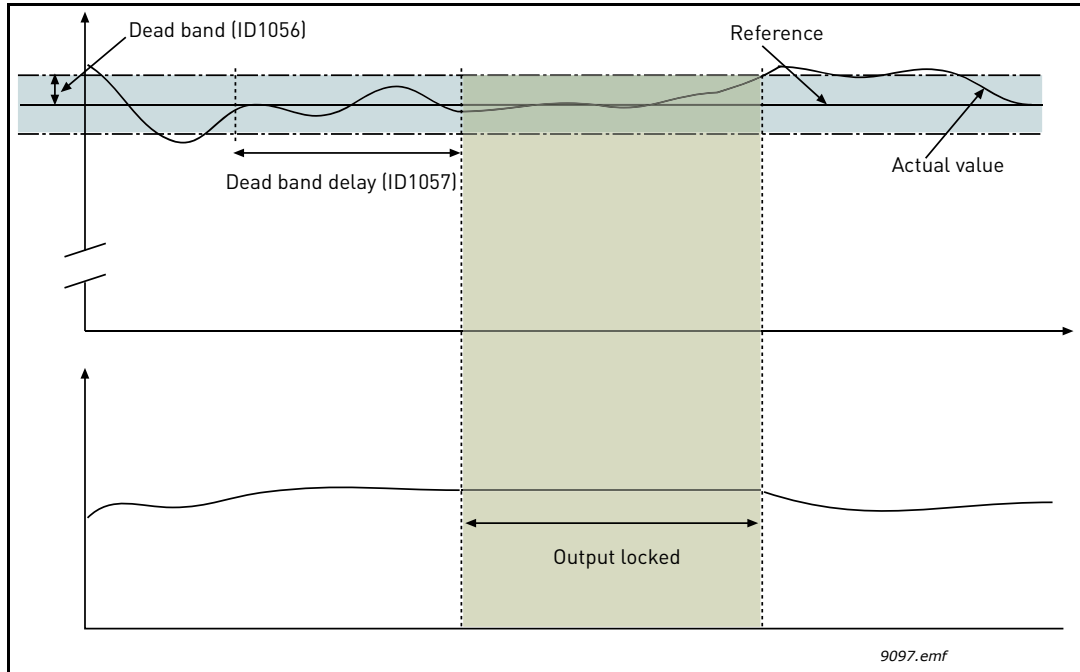

Figure 63. Dead band

**P3.13.5.1 SLEEP FREQUENCY LIMIT 1**

**P3.13.5.2 SLEEP DELAY 1**

**P3.13.5.3 WAKE-UP LEVEL 1**

This function will put the drive into sleep mode if the frequency stays below the sleep limit for a longer time than that set with the Sleep Delay (P3.13.5.2). This means that the start command remains on, but the run request is turned off. When the actual value goes below, or above, the wake-up level depending on the set acting mode the drive will activate the run request again if the start command is still on.

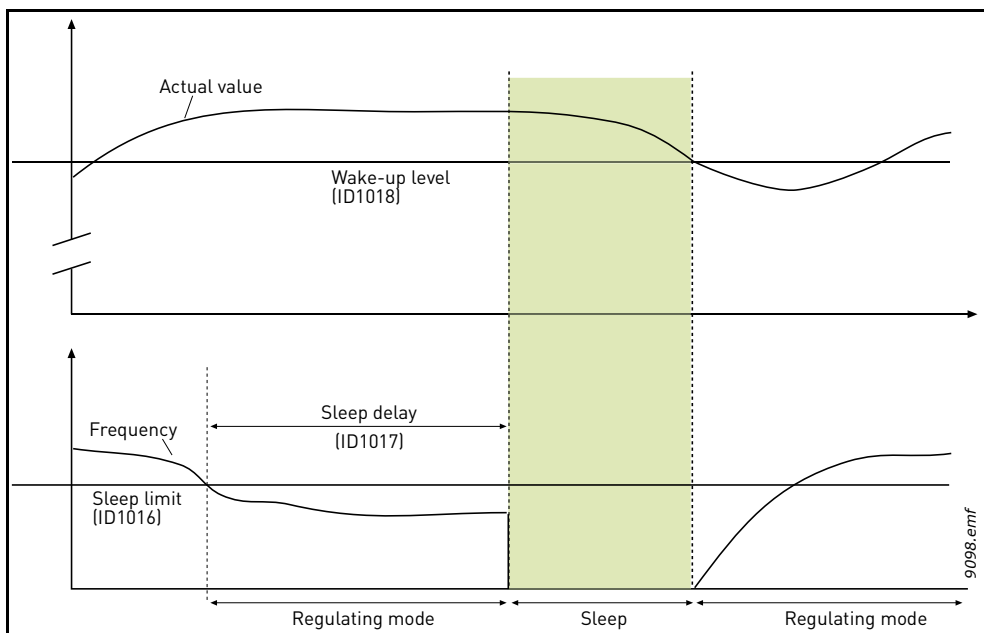

Figure 64. Sleep limit, Sleep delay, Wake-up level

**P3.13.4.1 FEEDFORWARD FUNCTION**

Feedforward usually needs accurate process models, but in some simple cases a gain + offset type of feedforward is enough. The feedforward part does not use any feedback measurements of the actual controlled process value (water level in the example on page 165). Vacon feedforward control uses other measurements which are indirectly affecting the controlled process value.

**Example 1:**

Controlling the water level of a tank by means of flow control. The desired water level has been defined as a setpoint and the actual level as feedback. The control signal acts on the incoming flow.

The outflow could be thought of as a disturbance that can be measured. Based on the measurements of the disturbance, we can try to compensate for this disturbance by simple feedforward control (gain and offset) which is added to the PID output.

This way the controller would react much faster to changes in the outflow than if you just had measured the level.

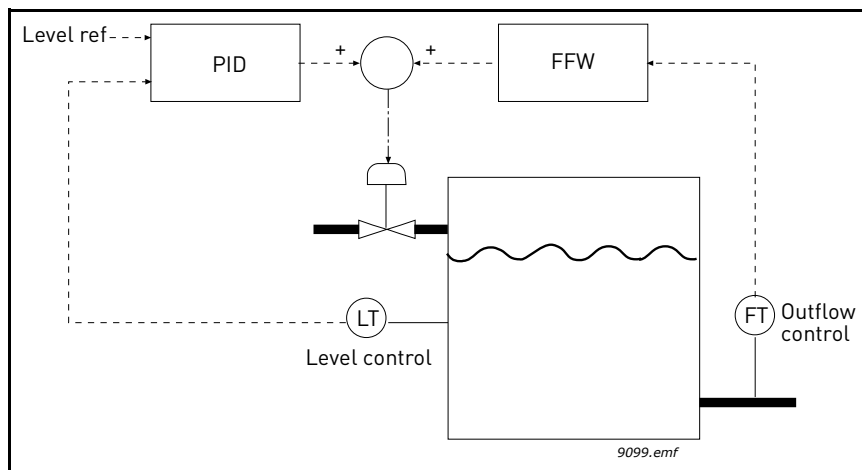

Figure 65. Feedforward control

**P3.13.6.1 ENABLE FEEDBACK SUPERVISION**

These parameters define the range within which the PID Feedback signal value is supposed to stay in a normal situation. If the PID Feedback signal goes above or below the defined supervision range for longer time than what is defined as the *Delay*, a PID Supervision fault (F101) will be triggered.



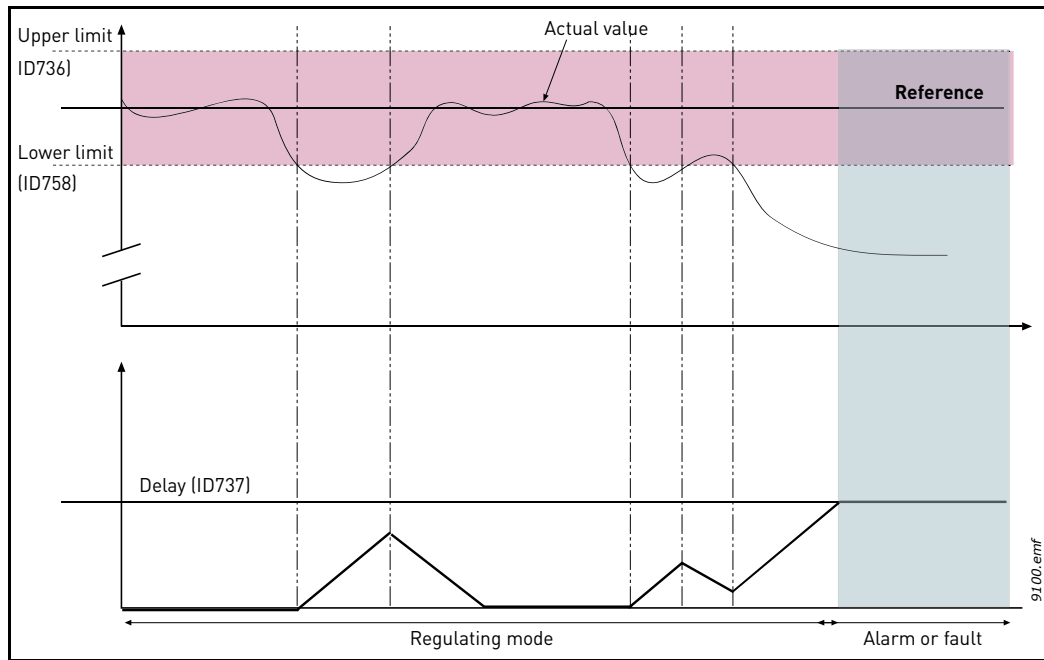
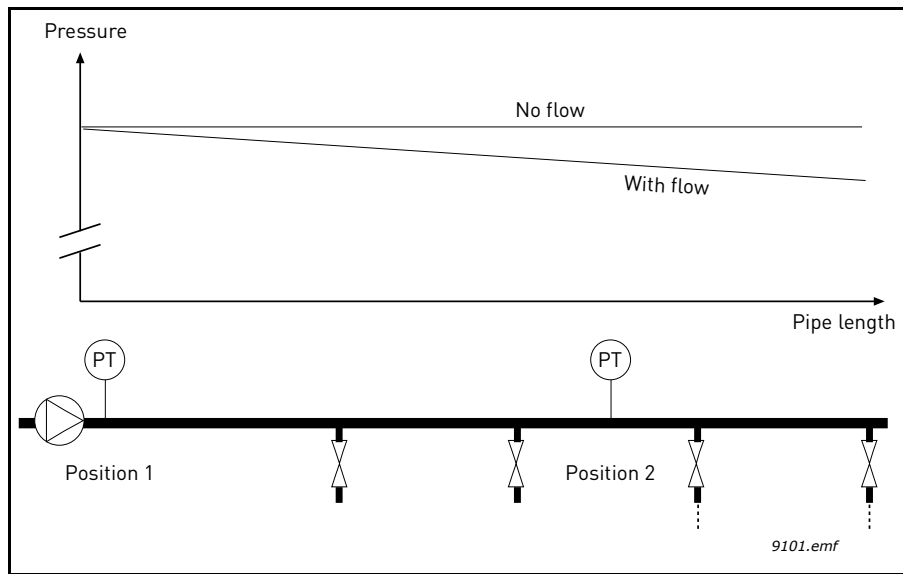

Figure 66. Feedback supervision

Upper and lower limits around the reference are set. When the actual value goes above or below these a counter starts counting up towards the Delay (P3.13.6.4). When the actual value is within the allowed area the same counter counts down instead. Whenever the counter is higher than the Delay an alarm or fault (depending on the selected response with parameter P3.13.6.5) is generated.

**PRESSURE LOSS COMPENSATION**



*Figure 67. Position of pressure sensor*

If pressurizing a long pipe with many outlets, the best place for the sensor would probably be halfway down the pipe (Position 2). However, sensors might, for example, be placed directly after the pump. This will give the right pressure directly after the pump, but farther down in the pipe the pressure will drop depending on the flow.

**P3.13.7.1 ENABLE SETPOINT 1**  
**P3.13.7.2 SETPOINT 1 MAX COMPENSATION**

The sensor is placed in Position 1. The pressure in the pipe will remain constant when we have no flow. However, with flow, the pressure will drop farther down in the pipe. This can be compensated by raising the setpoint as the flow increases. In this case, the flow is estimated by the output frequency and the setpoint is linearly increased with the flow as in the figure below.

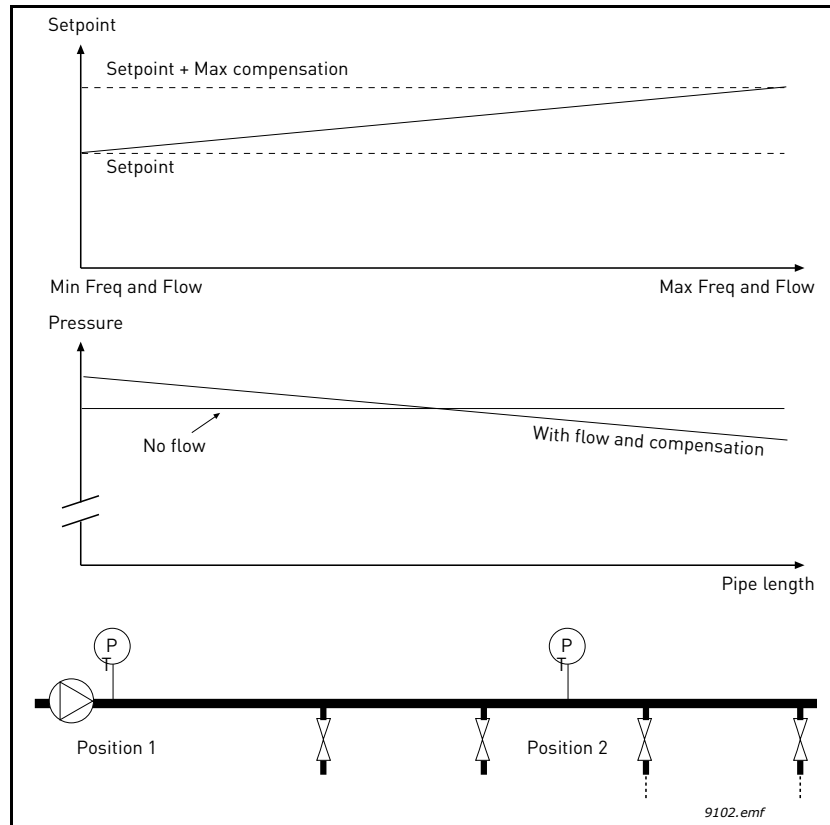

Figure 68. Enable setpoint 1 for pressure loss compensation

**SOFT FILL**

- P3.13.8.1**    **ENABLE SOFT FILL**
- P3.13.8.2**    **SOFT FILL FREQUENCY**
- P3.13.8.3**    **SOFT FILL LEVEL**
- P3.13.8.4**    **SOFT FILL TIMEOUT**

The drive runs at the soft fill frequency (par. P3.13.8.2) until the feedback value reaches the soft fill level set parameter P3.13.8.3. After this the drive starts to regulate, bump less, from the soft fill frequency. If the soft fill level is not reached within the timeout (P3.13.8.4) an alarm or fault is triggered (according to the set Soft Fill timeout response (P3.9.1.9)).

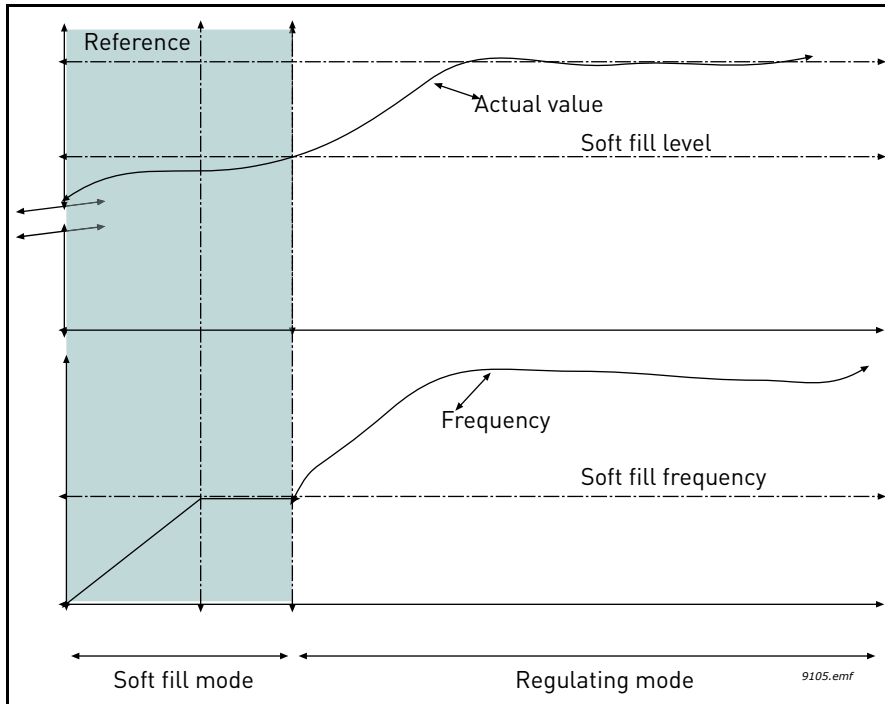

Figure 69. Soft fill function

### MULTI-PUMP USE

A motor/motors are connected/disconnected if the PID controller is not able to keep the process value or feedback within the defined bandwidth around the setpoint.

Criteria for connecting/adding motors (also see 70):

- Feedback value outside the bandwidth area.
- Regulating motor running at a “close-to-max” frequency (-2Hz)
- Conditions above are fulfilled for a time longer than the bandwidth delay
- There are more motors available

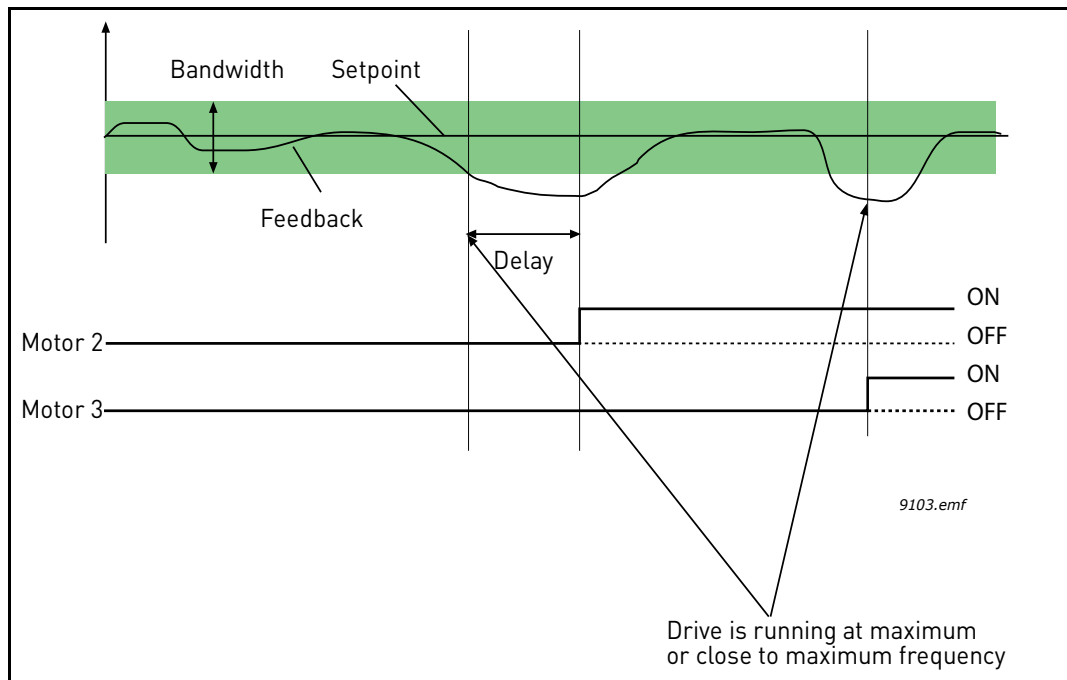

Figure 70.

Criteria for disconnecting/removing motors:

- Feedback value outside bandwidth area.
- Regulating motor running at a “close-to-min” frequency (+2 Hz)
- Conditions above are fulfilled for a time longer than the bandwidth delay
- There are more motors running than the regulating one.

#### P3.15.2 INTERLOCK FUNCTION

Interlocks can be used to tell the Multi Pump system that a motor is not available e.g. because of the motor is removed from the system for maintenance or bypassed for manual control.

Enable this function to use the interlocks. Choose the needed status for each motor by digital inputs (parameters P3.5.1.34 to P3.5.1.37). If the input is closed (TRUE) the motor is available for the Multi Pump system, otherwise it will not be connected by the Multi Pump logic.

**EXAMPLE OF THE INTERLOCK LOGIC:**

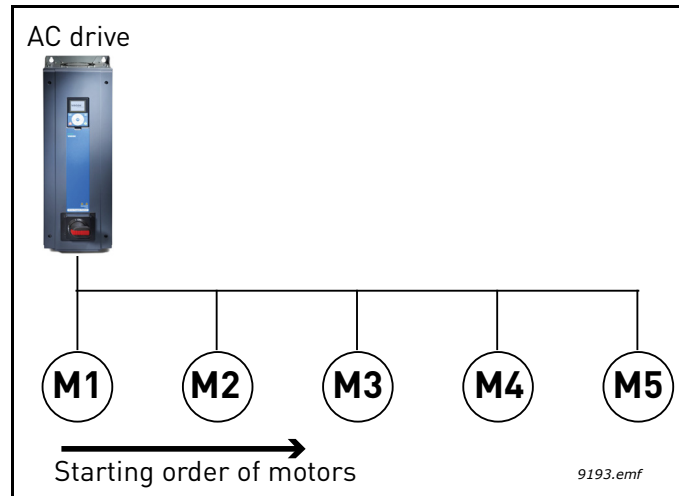

Figure 71. Interlock logic 1

If the motor starting order is

**1->2->3->4->5**

Now, the interlock of motor **3** is removed, i.e. the value of parameter P3.5.1.36 is set to FALSE, the order changes to **1->2->4->5**.

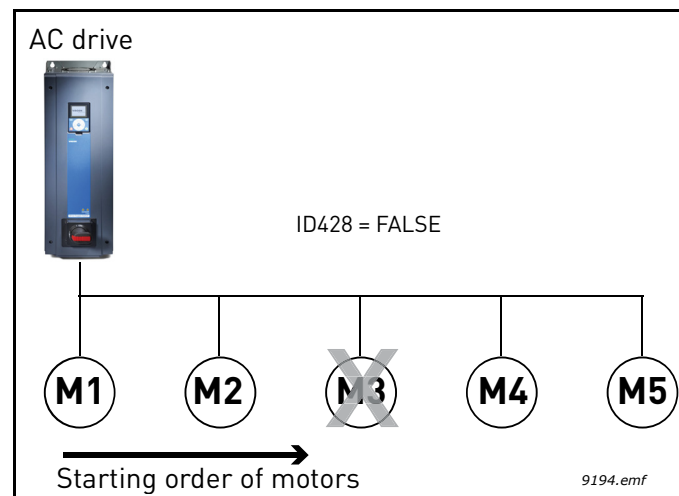

Figure 72. Interlock logic 2

If motor **3** is taken into use again (changing the value of parameter P3.5.1.36 to TRUE) the system runs on without stopping and motor **3** is placed last in the sequence: **1->2->4->5->3**

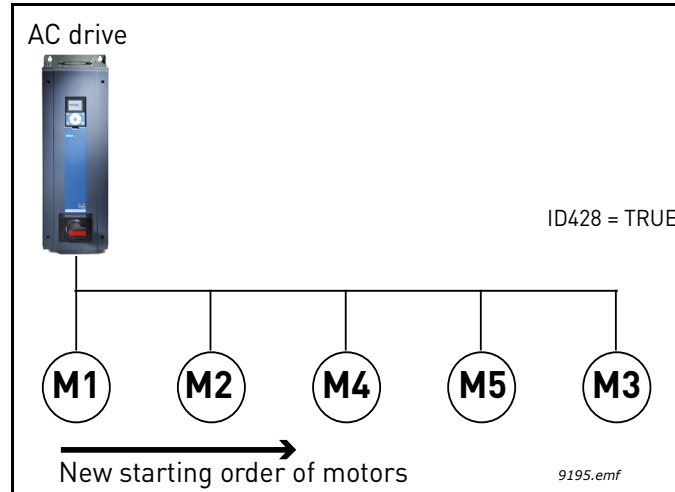

Figure 73. Interlock logic 3

As soon as the system is stopped or goes to sleep mode for the next time, the sequence is updated to its original order.

1->2->3->4->5

**P3.15.3 INCLUDE FC**

Table 134.

Selection	Selection name	Description
0	Disabled	Motor 1 (motor connected to AC drive) is always frequency controlled and not affected by interlocks.
1	Enabled	All motors can be controlled and are affected by interlocks.

**WIRING**

There are two different ways to make the connections depending on whether selection 0 or 1 is set as parameter value.

**Selection 0, Disabled:**

The AC drive or the regulating motor is not included in the autochange or interlocks logic. The drive is directly connected to motor 1 as in 74 below. The other motors are auxiliary ones connected to the mains by contactors and controlled by relays in the drive.

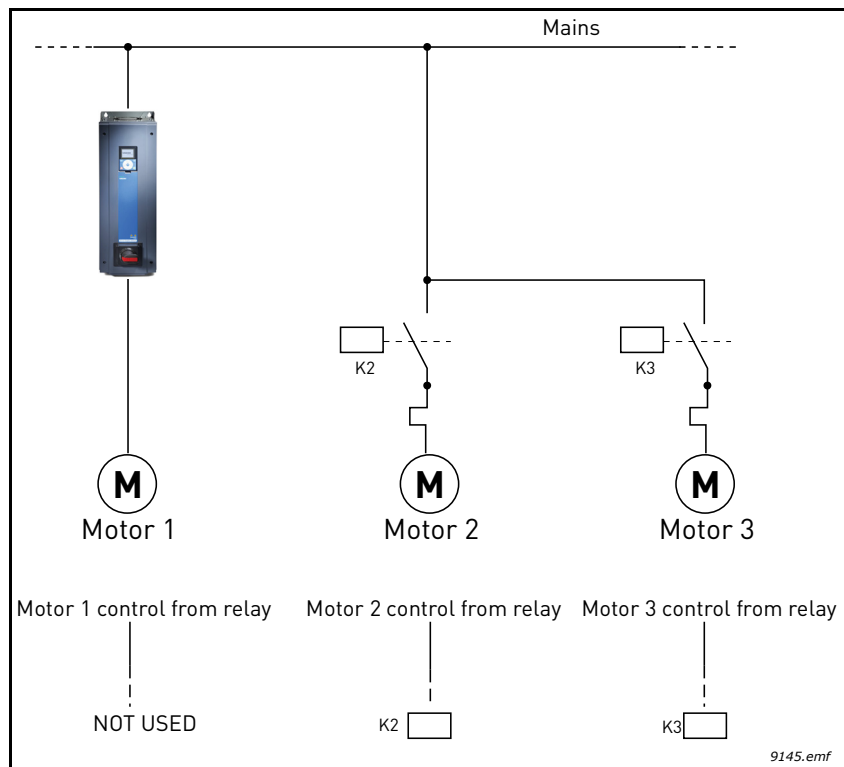

Figure 74.

**Selection 1, Enabled:**

If the regulating motor needs to be included in the autochange or interlock logic make the connection according to 75 below.

Every motor is controlled with one relay but the contactor logic takes care that the first connected motor is always connected to the drive and next to the mains.



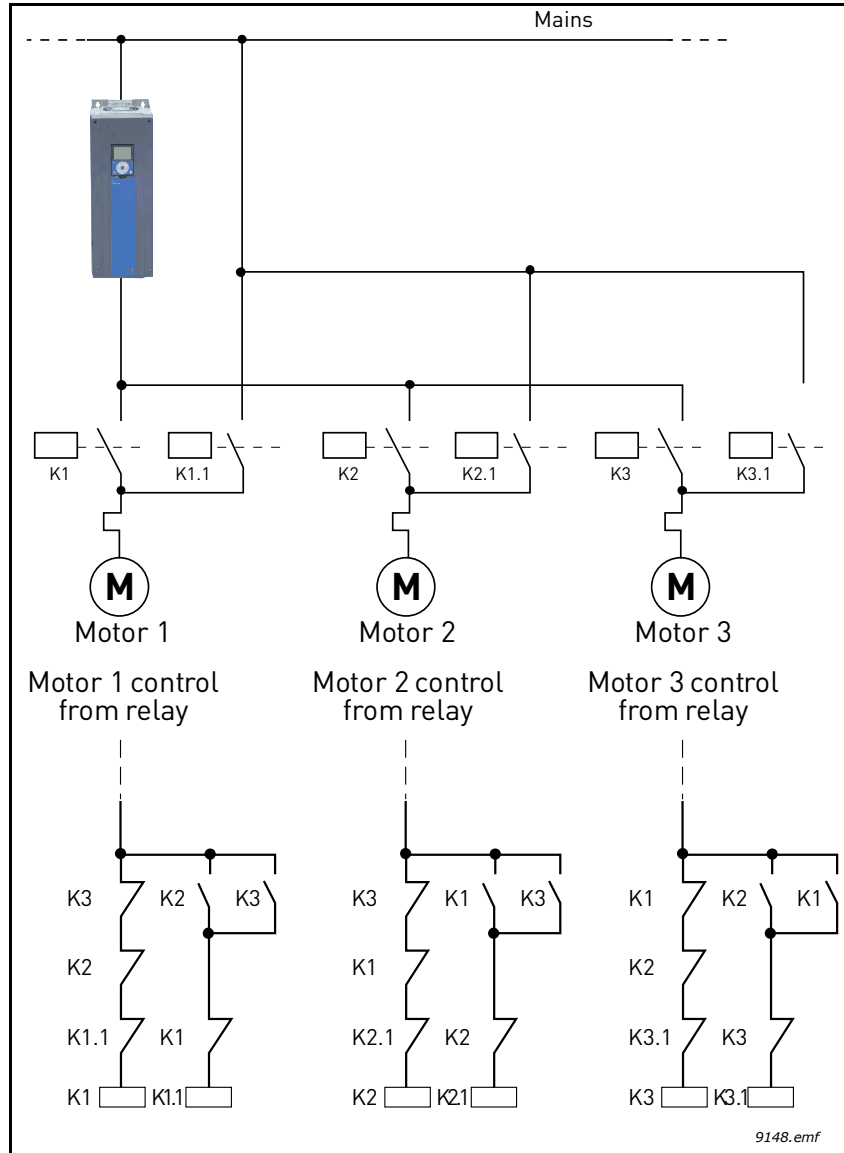

Figure 75.

**P3.15.4 AUTOCHANGE**

Table 135.

Selection	Selection name	Description
0	Disabled	The priority/starting order of the motors is always 1-2-3-4-5 in normal operation. It might have changed during run if interlocks have been removed and added again, but the priority/order is always restored after a stop.
1	Enabled	The priority is changed at certain intervals to get an equal wear on all motors. The intervals of the auto-change can be changed (P3.15.5). You can also set a limit of how many motors are allowed to run (P3.15.7) as well as for the maximum frequency of the regulating drive when the autochange is done (P3.15.6). If the autochange interval (P3.15.5) has expired, but the frequency and motor limits are not fulfilled, the autochange will be postponed until all conditions are met (this is to avoid e.g. sudden pressure drops because of the system performing an auto-change when there is a high capacity demand at a pump station).

**EXAMPLE:**

In the autochange sequence after the autochange has taken place, the motor with the highest priority is placed last and the others are moved up by one place:

Starting order/priority of motors: **1->2->3->4->5**

--> *Autochange* -->

Starting order/priority of motors: **2->3->4->5->1**

--> *Autochange* -->

Starting order/priority of motors: **3->4->5->1->2**

**P3.15.16.1 ENABLE OVERPRESSURE SUPERVISION**

If the Overpressure supervision is enabled and the PID feedback signal (pressure) exceeds the supervision level defined by parameter P3.15.16.2 all auxiliary motors will be stopped in the Multi-Pump system. Only the regulating motor keeps running normally. Once the pressure decreases, the system will continue working normally, re-connecting the auxiliary motors one by one. See 76.

The Overpressure supervision function will monitor the PID Controller feedback signal and stop all auxiliary pumps immediately if the signal exceeds the overpressure level defined .

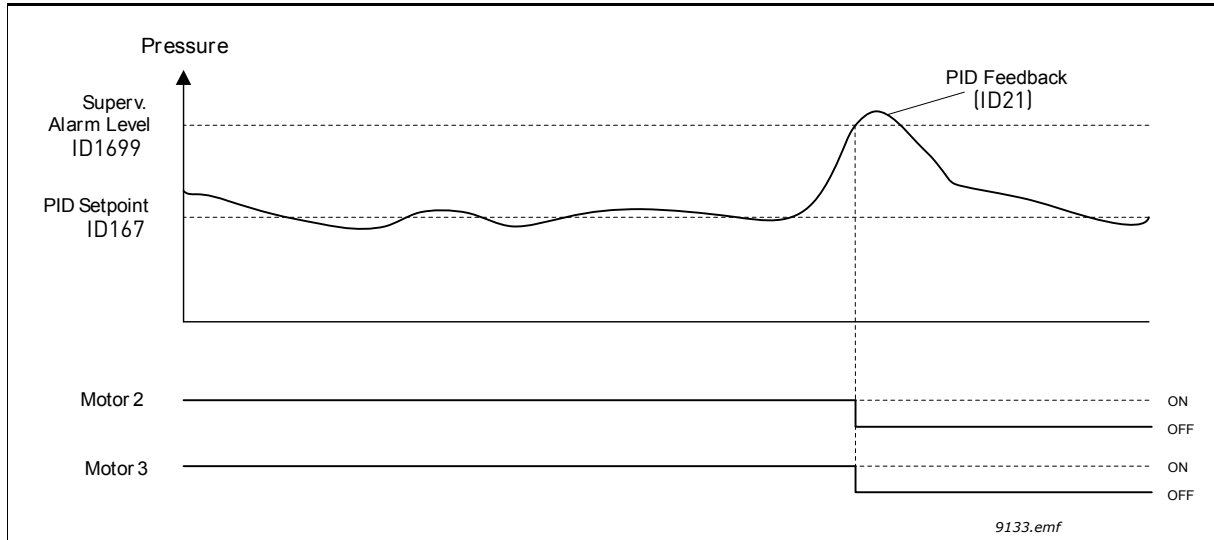

Figure 76. Overpressure supervision

**P3.17.1 FIRE MODE PASSWORD**

Choose here the operation mode of the Fire mode function.

Selection	Selection name	Description
1002	Enabled mode	The drive will reset all upcoming faults and continue running at the given speed as long as it is possible. <b>NOTE!</b> All Fire mode parameters will be locked if this password has been given. To enable changing the Fire mode parameterization, first change the parameter value to zero first.
1234	Test mode	Upcoming errors will not be reset automatically and the drive will stop if any fault occurs.

**P3.17.3 FIRE MODE FREQUENCY**

This parameter defines the constant frequency reference that is used when Fire mode has been activated and *Fire mode frequency* has been selected to frequency reference source in parameter P3.17.2.

See parameter P3.17.6 to select or change the motor rotation direction when Fire mode function is active.

**P3.17.4 FIRE MODE ACTIVATION ON OPEN**

If activated, alarm sign is shown on the keypad and warranty is void. In order to enable the function, you need to set a password in the description field for parameter Fire Mode password. Please note the NC (normally closed) type of this input!

It is possible to test the *Fire mode* without voiding the warranty by using the password that allows the *Fire mode* to run in test state. In the test state, upcoming errors will not automatically be reset and the drive will stop at faults.

**NOTE!** All Fire mode parameters will be locked if Fire mode is enabled and correct password is given to the Fire mode Password parameter. To change the Fire mode parameterization, change the *Fire Mode Password* parameter to zero first.

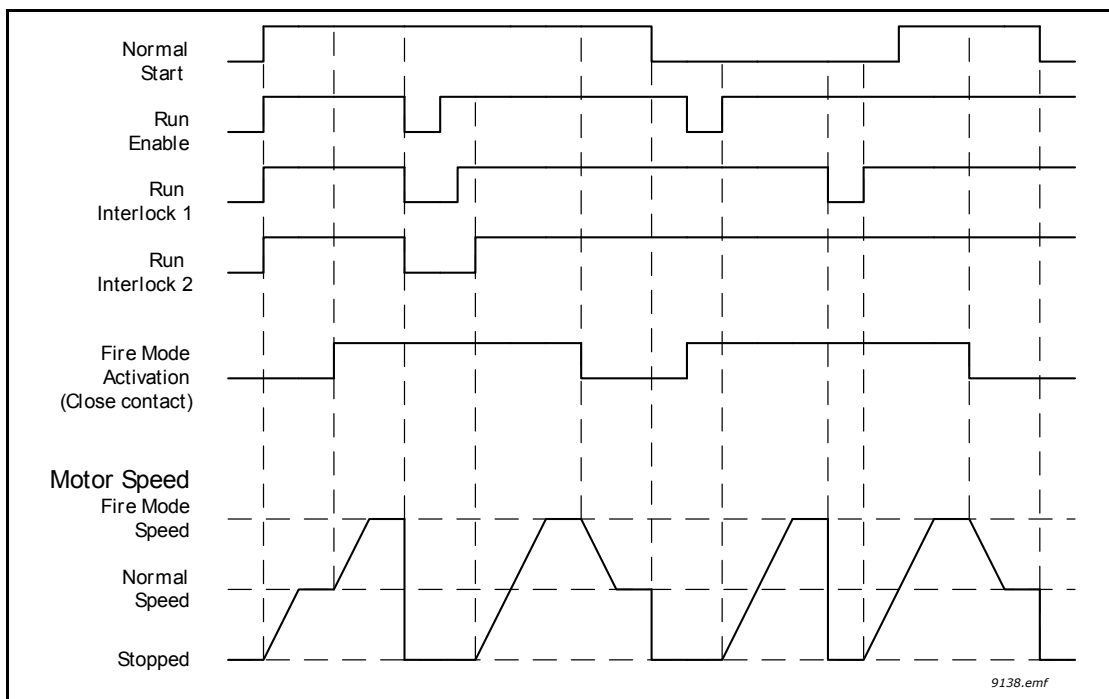

Figure 77. Fire Mode functionality

**P3.17.5 FIRE MODE ACTIVATION ON CLOSE**

See above.

**P3.17.6 FIRE MODE REVERSE**

This parameter defines the digital input signal to select the motor rotation direction with activated Fire Mode function. It has no effect in normal operation.

If the motor is required to run always FORWARD or always REVERSE in Fire Mode, select:

- DigIn Slot0.1 = always FORWARD
- DigIn Slot0.2 = always REVERSE

**P3.18.1 MOTOR PREHEAT FUNCTION**

Motor Preheat function is intended to keep the drive and motor warm in Stop state by injecting DC current to the motor e.g. to prevent condensation.

Selection	Selection name	Description
0	Not used	Motor preheat function is disabled.
1	Always in Stop state	Motor preheat function is activated always when the drive is in Stop state.
2	Controlled by digital input	Motor preheat function is activated by a digital input signal, when the drive is in Stop state. The DI for the activation can be selected by parameter P3.5.1.18.

Selection	Selection name	Description
3	Temperature limit (heat-sink)	Motor preheat function is activated if the drive is in Stop state and the temperature of the drive's heatsink goes below the temperature limit defined by parameter P3.18.2.
4	Temperature limit (measured motor temperature)	Motor preheat function is activated if the drive is in Stop mode and the (measured) motor temperature goes below the temperature limit defined by parameter P3.18.2. The measurement signal of the motor temperature can be selected by parameter P3.18.5. <b>NOTE!</b> This operation mode presupposes the installation of a temperature measurement option board (e.g. OPTBH).

**P3.20.1 BRAKE CONTROL**

Mechanical brake control is used to control an external mechanical brake by a digital output signal. Brake open/close command can be selected as a function of the digital output. Mechanical brake will be opened/closed when drive output frequency reaches defined opening/closing limits. The status of Mechanical Brake can also be supervised by monitoring value Application Status Word 1 in monitoring group Extras & advanced if the brake feedback signal is connected to one of the drive's digital inputs and the supervision is enabled.

Selection	Selection name	Description
0	Disabled	Mechanical brake control is not used
1	Enabled	Mechanical brake control is used, but the brake status is not supervised.
2	Enabled with brake status supervision	Mechanical brake control is used and the brake status is supervised by a digital input signal (P3.5.1.44).

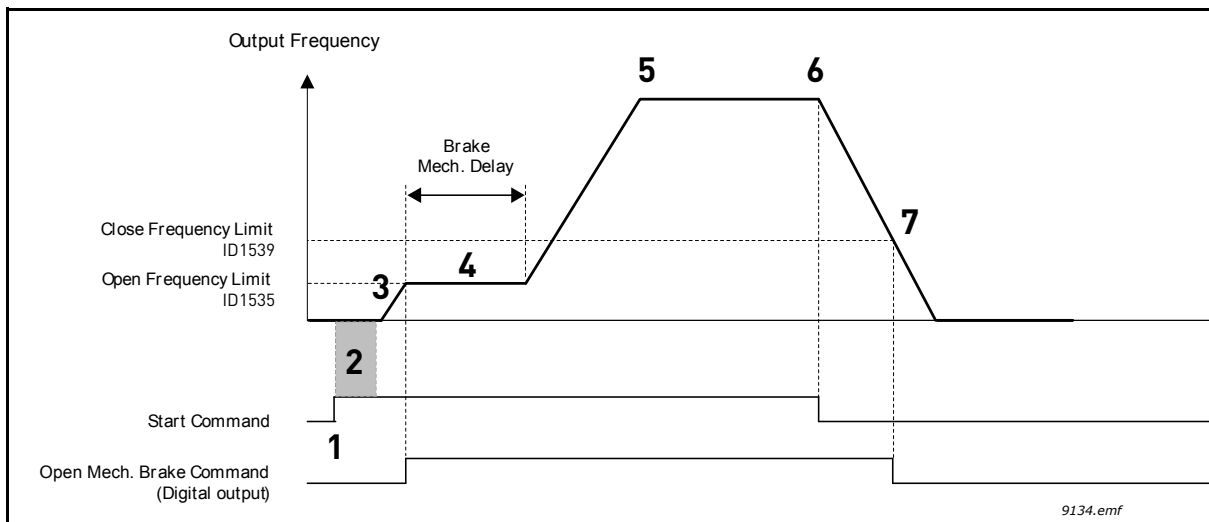

Figure 78. Mechanical brake functionality

1	Start command is given.	5	The output frequency of the drive follows the normal frequency reference.
2	It is recommended to use <i>Start magnetization</i> (see page 76) to build rotor flux fast and decrease the time when the motor is able to produce nominal torque.	6	Stop command is given.
3	When the Start magnetization time has elapsed, frequency reference is released to <i>Brake opening frequency limit</i> .	7	The Mechanical brake will be closed when the output frequency goes below the <i>Brake closing frequency limit</i> .
4	The mechanical brake is opened and the frequency reference is kept at the <i>Brake opening frequency limit</i> until the <i>Brake mechanical delay</i> time has elapsed and correct brake feedback status signal has been received.		

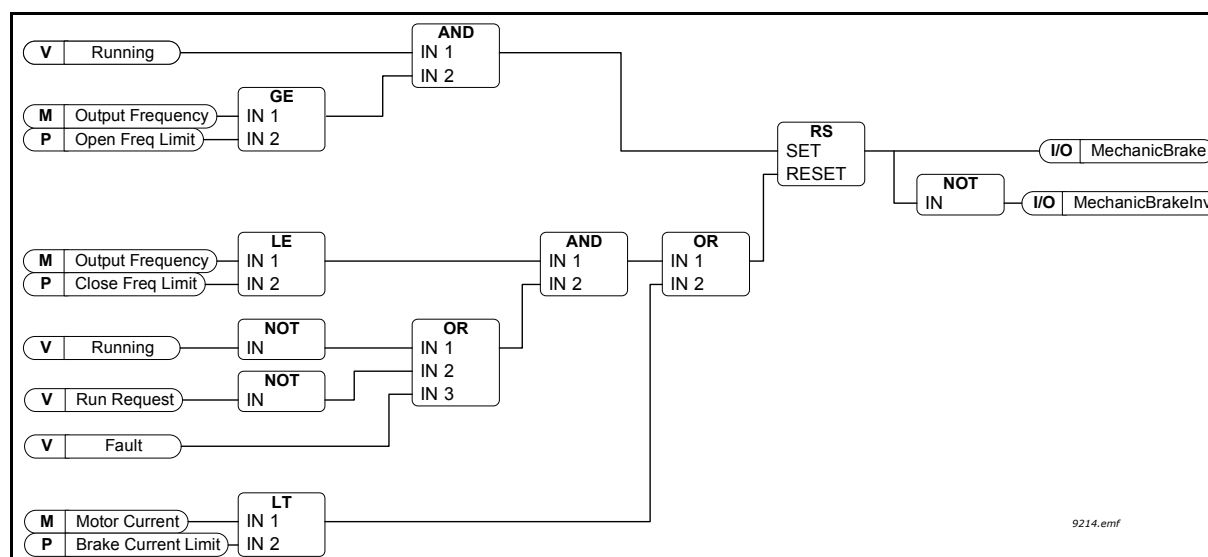

Figure 79. Mechanical brake opening logic

**P3.20.2 BRAKE MECHANICAL DELAY**

After the brake open command has been given, the speed is kept at the *Brake opening frequency limit* until the *Brake mechanical delay* has passed. This hold time should be set corresponding to the mechanical brake reaction time. The function is used to avoid current and/or torque spikes eliminating a situation where the motor is run at full speed against the brake. If this parameter is used simultaneously with the digital input signal *Mechanical brake feedback*, both the expired delay and the feedback signal are needed before the speed reference is released.

**P3.20.3 BRAKE OPENING FREQUENCY LIMIT**

The output frequency limit of the drive to open the mechanical brake. In *open loop control*, it is recommended to use a value equal to the motor’s nominal slip.

The drive’s output frequency will be held at this level until the *Brake mechanical delay* has elapsed and the correct brake feedback signal is received.

**P3.20.4 BRAKE CLOSING FREQUENCY LIMIT**

The output frequency limit to close the mechanical brake when the drive is stopping and the output frequency is approaching zero. This parameter is used for both positive and negative directions.

**P3.20.5 BRAKE CURRENT LIMIT**

The Mechanical brake will close immediately if the motor current is below this limit. It is recommended to set this value to approximately the half of the magnetization current.

When operating on the field weakening area, the Brake current limit will be internally reduced as a function of output frequency.

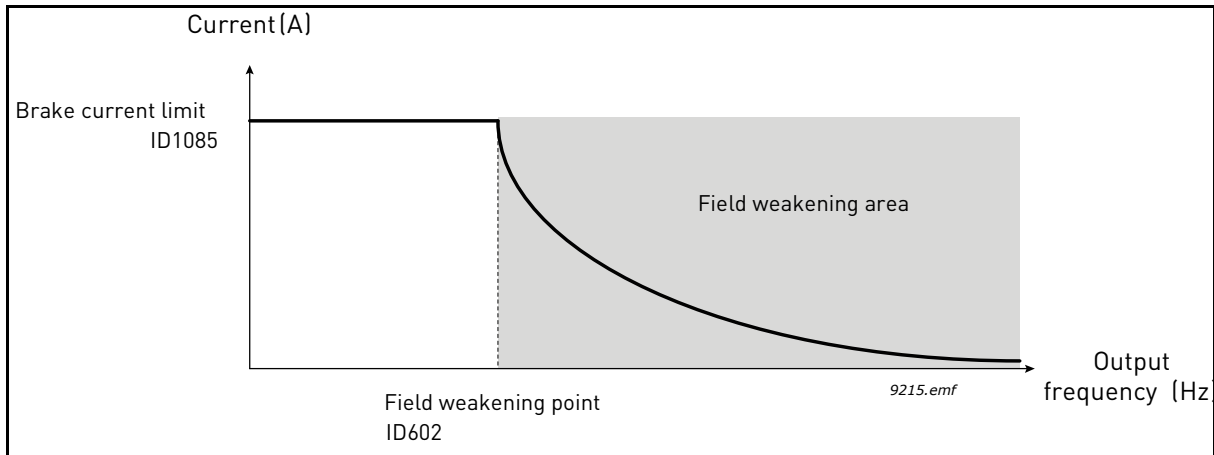

Figure 80. Internal reduction of Brake current limit

**P3.5.1.44 BRAKE FEEDBACK**

Digital input selection for mechanical brake status signal. The Brake feedback signal is used if the mechanical brake status supervision is active (parameter P3.20.1 = 2/Enabled,Supervised).

Connect this digital input signal to an auxiliary contact of the mechanical brake.

- Contact is open = Brake is closed
- Contact is closed = Brake is open

If the brake is controlled to open but the Brake feedback signal contact is not closed within given time, a *Mechanical brake fault* (F58) will be generated.

**P3.21.1.1 CLEANING FUNCTION**

If Auto-cleaning function is enabled by parameter P3.21.1.1 the Auto-cleaning sequence will start by activating the digital input signal selected by parameter P3.21.1.2.

**P3.21.1.2 CLEANING ACTIVATION**

See above.

**P3.21.1.3 CLEANING CYCLES**

The Forward/reverse cycle will be repeated for the amount of times defined by this parameter.

**P3.21.1.4 CLEAN FORWARD FREQUENCY**

Auto-cleaning function is based on rapidly accelerating and decelerating the pump. The user can define a forward/reverse cycle by setting parameters P3.21.1.4, P3.21.1.5, P3.21.1.6 and P3.21.1.7.

**P3.21.1.5 CLEAN FORWARD TIME**

See parameter P3.21.1.4 Clean forward frequency above.

**P3.21.1.6 CLEAN REVERSE FREQUENCY**

See parameter P3.21.1.4 Clean forward frequency above.

**P3.21.1.7 CLEAN REVERSE TIME**

See parameter P3.21.1.4 Clean forward frequency above.

**P3.21.1.8 CLEANING ACCELERATION TIME**

The user can also define separated acceleration and deceleration ramps for the Auto-cleaning function with parameters P3.21.1.8 and P3.21.1.9.

**P3.21.1.9 CLEANING DECELERATION TIME**

See parameter P3.21.1.8 Cleaning acceleration time above.

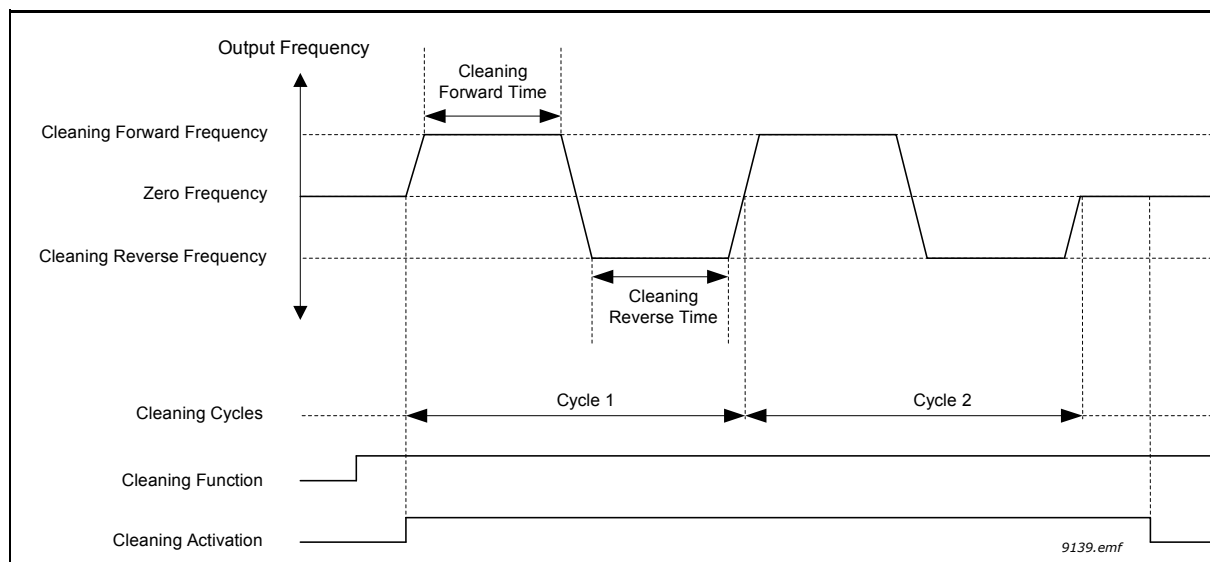

Figure 81. Auto-cleaning functionality



**P3.21.2.1 JOCKEY FUNCTION**

Jockey pump function is used to control a smaller jockey pump by a digital output signal. Jockey pump can be used if a PID Controller is used for controlling the main pump. This function has three operation modes:

Table 136.

Selection number	Selection name	Description
0	Not used	
1	PID sleep	Jockey pump will start when the PID Sleep on the main pump is active and stopped when the main pump wakes from sleep.
2	PID sleep (level)	Jockey pump will start when PID Sleep is active and the PID feedback signal goes below the level defined by parameter P3.21.2.2. Jockey Pump will be stopped when the feedback exceeds the level defined by parameter P3.21.2.3 or the main pump wakes from sleep.

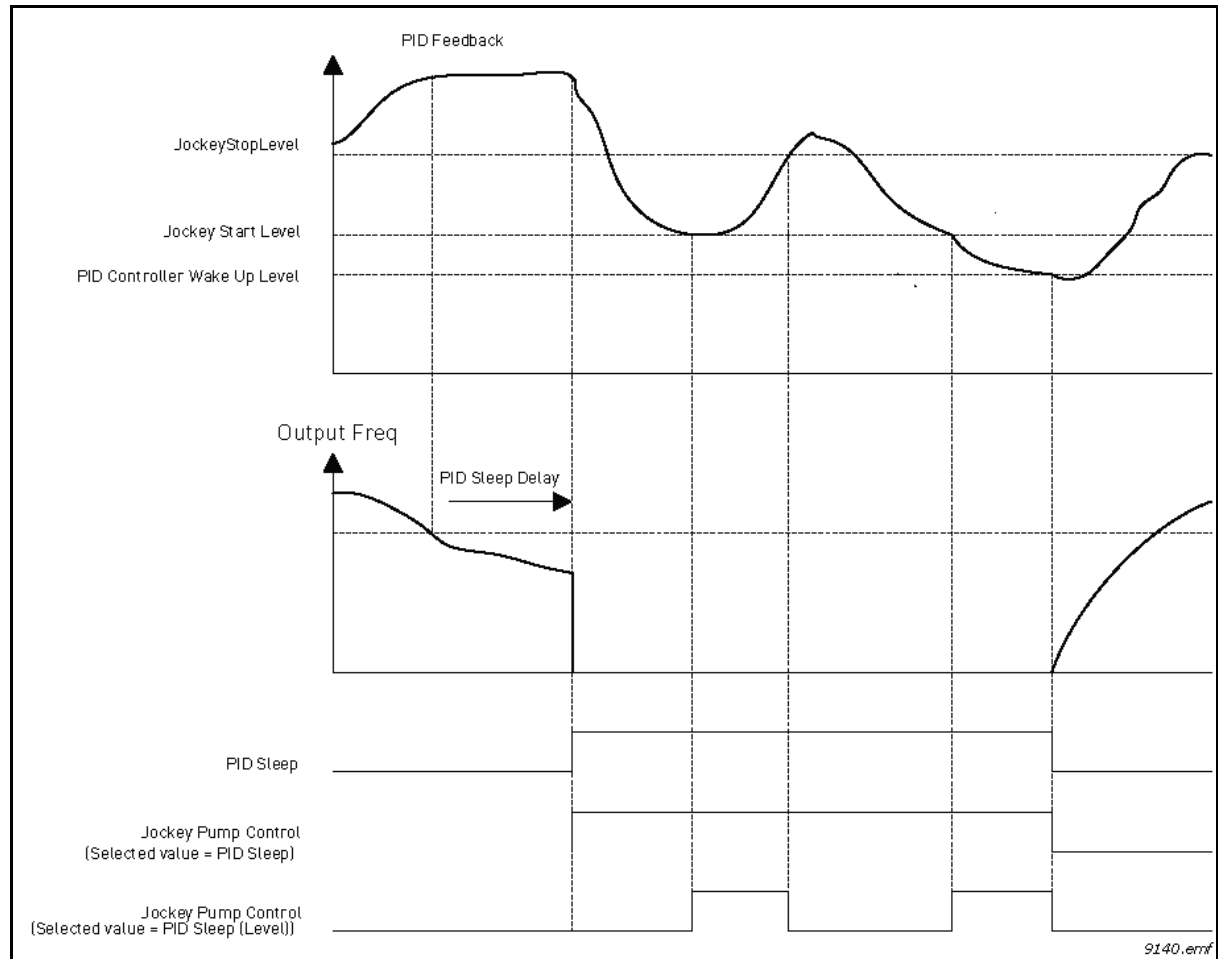

Figure 82. Jockey pump control functionality

**P3.21.3.1 PRIMING FUNCTION**

Enables control of an external priming pump via digital output if *Priming pump control* has been selected for value of the desired digital output. The priming pump will run continuously as long the main pump is running.

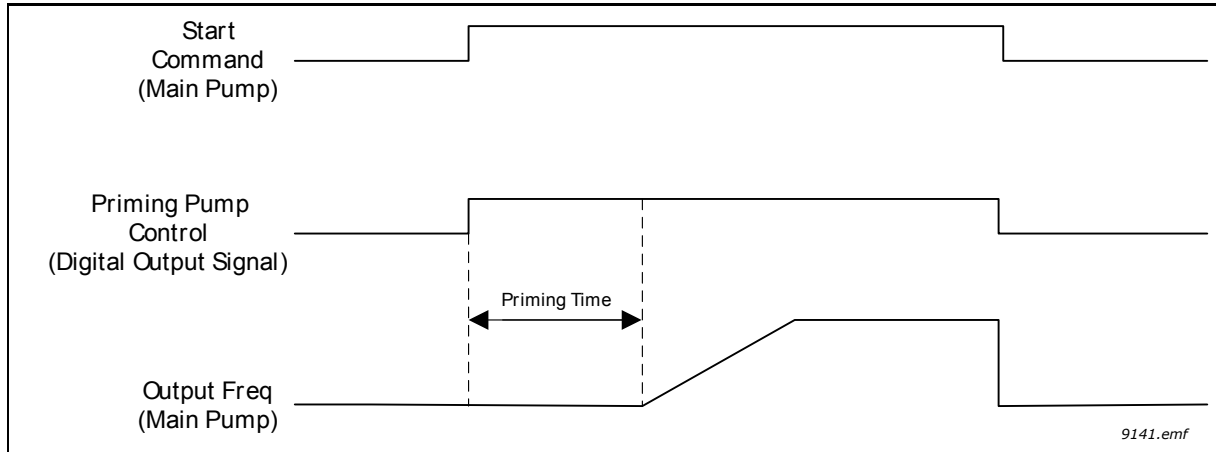

Figure 83.

**P3.21.3.2 PRIMING TIME**

Defines the time to start the priming pump before the main pump is started.

### 3.6 FAULT TRACING

When an unusual operating condition is detected by the AC drive control diagnostics, the drive initiates a notification visible, for example, on the keypad. The keypad will show the code, the name and a short description of the fault or alarm.

The notifications vary in consequence and required action. *Faults* make the drive stop and require reset of the drive. *Alarms* inform of unusual operating conditions but the drive will continue running. *Infos* may require resetting but do not affect the functioning of the drive.

For some faults you can program different responses in the application. See parameter group Protections.

The fault can be reset with the *Reset button* on the control keypad or through the I/O terminal, fieldbus or PC tool. The faults are stored in the Fault history menu which can be browsed. The different fault codes you will find in the table below.

**NOTE:** When contacting distributor or factory because of a fault condition, always write down all texts on the display, the fault code, the fault ID, the source info, the Active Fault list and the Fault History.

#### 3.6.1 FAULT APPEARS

When a fault appears and the drive stops examine the cause of fault, perform the actions advised here and reset the fault either

1. with a long (2 s) press on the *Reset* button on the keypad or
2. by entering the *Diagnostics* Menu (M4), entering *Reset faults* (M4.2) and selecting *Reset faults* parameter.

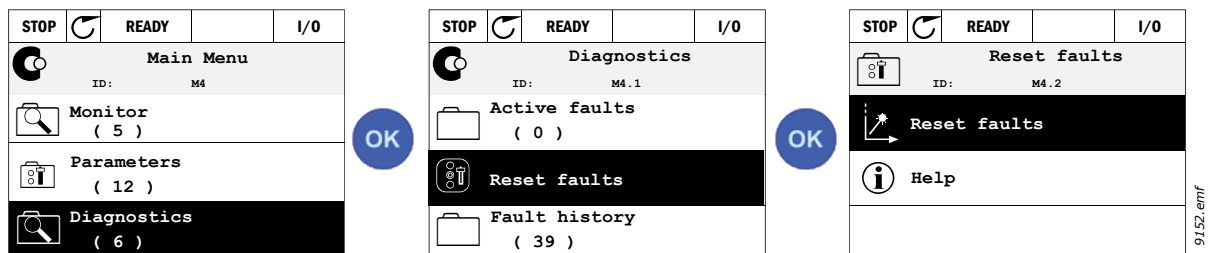

3. **For text keypad only:** By selecting value Yes for the parameter and clicking OK.

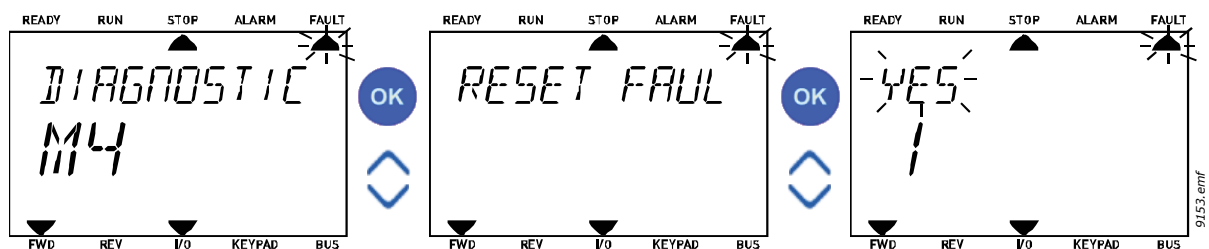

### 3.6.2 FAULT HISTORY

In menu M4.3 Fault history you find the maximum number of 40 occurred faults. On each fault in the memory you will also find additional information, see below.

STOP	READY	I/O
Diagnostics		
ID: M4.1		
Active faults ( 0 )		
Reset faults		
Fault history ( 39 )		

OK

STOP	READY	I/O
Fault history		
ID: M4.3.3		
External Fault	51	
Fault old	891384s	
External Fault	51	
Fault old	871061s	
Device removed	39	
Info old	862537s	

>

STOP	READY	I/O
Device removed		
ID: M4.3.3.2		
Code	39	
ID	380	
State	Info old	
Date	7.12.2009	
Time	04:46:33	
Operating time	862537s	

9154.emf

The displays on the Text keypad:

READY RUN STOP ALARM FAULT	READY RUN STOP ALARM FAULT	READY RUN STOP ALARM FAULT
FAULT HIST	COMMUNICAT	CODE
M4.3	M4.3 1	65
FWD REV I/O KEYPAD BUS	FWD REV I/O KEYPAD BUS	FWD REV I/O KEYPAD BUS

OK
OK
>

READY RUN STOP ALARM FAULT	READY RUN STOP ALARM FAULT
10	STATE
1065	2
FWD REV I/O KEYPAD BUS	FWD REV I/O KEYPAD BUS

9155.emf

3.6.3 FAULT CODES

Fault code	Fault ID	Fault name	Possible cause	Remedy
1	1	Overcurrent (hardware fault)	AC drive has detected too high a current ( $>4 \cdot I_M$ ) in the motor cable:	Check loading. Check motor. Check cables and connections. Make identification run. Set acceleration time longer (P3.4.1.2/ P3.4.2.2).
	2	Overcurrent (software fault)	<ul style="list-style-type: none"> <li>• sudden heavy load increase</li> <li>• short circuit in motor cables</li> <li>• unsuitable motor</li> <li>• parameter settings are not properly made</li> </ul>	
2	10	Overvoltage (hardware fault)	The DC-link voltage has exceeded the limits defined.	Set deceleration time longer (P3.4.1.3/P3.4.2.3).. Use brake chopper or brake resistor (available as options). Activate overvoltage controller. Check input voltage.
	11	Overvoltage (software fault)	<ul style="list-style-type: none"> <li>• too short a deceleration time</li> <li>• high overvoltage spikes in supply</li> </ul>	
3	20	Earth fault (hardware fault)	Current measurement has detected that the sum of motor phase current is not zero.	Check motor cables and motor. Check filters.
	21	Earth fault (software fault)	<ul style="list-style-type: none"> <li>• insulation failure in cables or motor</li> <li>• filter (du/dt, sinus) failure</li> </ul>	
5	40	Charging switch	Charging switch is closed and the feedback information still is 'OPEN'. <ul style="list-style-type: none"> <li>• faulty operation</li> <li>• component failure</li> </ul>	Reset the fault and restart. Check the feedback signal and the cable connection between the control board and the power board. Should the fault re-occur, contact the distributor near to you.
7	60	Saturation	Various causes: <ul style="list-style-type: none"> <li>• IGBT does not execute its operation (is defective)</li> <li>• de-saturation short-circuit in IGBT</li> <li>• brake resistor short-circuit or overload</li> </ul>	Cannot be reset from keypad. Switch off power. <b>DO NOT RESTART or RE-CONNECT POWER!</b> Contact factory.

Fault code	Fault ID	Fault name	Possible cause	Remedy	
8	600	System fault	Communication between control board and power unit has failed.	Reset the fault and restart. Download and update with the latest software available on Vacon website. Should the fault re-occur, contact the distributor near to you.	
	601				
	602		Component failure. Faulty operation.		
	603		Component failure. Faulty operation. Voltage of auxiliary power in power unit is too low.		
	604		Component failure. Faulty operation. Output phase voltage does not follow the reference. Feedback fault.		
	605		Component failure. Faulty operation.		
	606		Control and power unit software are incompatible		
	607		Software version cannot be read. There is no software in power unit. Component failure. Faulty operation (power board or measurement board problem).		
	608		CPU overload.		
	609		Component failure. Faulty operation.		RESET the fault and power the drive down twice. Download and update with the latest software available on Vacon website.
	610		Component failure. Faulty operation.		Reset the fault and restart. Download and update with the latest software available on Vacon website. Should the fault re-occur, contact the distributor near to you.
	614		Configuration error Software error Component failure (control board) Faulty operation		
	647		Component failure. Faulty operation.		
	648		Faulty operation. System software and application are not compatible.		
	649		Resource overload. Parameter loading, restoring or saving failure.		

Fault code	Fault ID	Fault name	Possible cause	Remedy
9	80	Undervoltage (fault)	DC-link voltage is under the voltage limits defined. <ul style="list-style-type: none"> <li>• too low a supply voltage</li> <li>• component failure</li> <li>• defect input fuse</li> <li>• external charge switch not closed</li> </ul> <b>NOTE!</b> This fault is activated only if the drive is in Run state.	In case of temporary supply voltage break reset the fault and restart the AC drive. Check the supply voltage. If it is adequate, an internal failure has occurred. Check the electrical network for failures. Contact the distributor near to you.
10	91	Input phase	<ul style="list-style-type: none"> <li>• problem in supply voltage</li> <li>• fuse failure or failure in the supply cables</li> </ul> The load must be 10-20% minimum in order to the supervision to work.	Check supply voltage, fuses and supply cable, rectifying bridge and gate control of the thyristor (MR6->).
11	100	Output phase supervision	Current measurement has detected missing current in one motor phase. <ul style="list-style-type: none"> <li>• problem in motor or motor cables.</li> <li>• filter (du/dt, sinus) failure</li> </ul>	Check motor cable and motor. Check the du/dt or sinus filter.
12	110	Brake chopper supervision (hardware fault)	No brake resistor installed. Brake resistor is broken. Brake chopper failure.	Check brake resistor and cabling. If these are ok, the resistor or the chopper is faulty. Contact the distributor near to you.
	111	Brake chopper saturation alarm		
13	120	AC drive under-temperature (fault)	Too low temperature measured in power unit's heatsink or on power board.	The ambient temperature is too low for the AC drive. Move the AC drive in a warmer place.
14	130	AC drive over-temperature (fault, heatsink)	Too high temperature measured in power unit's heatsink or on the power board. Note: Heatsink temperature limits are frame-specific.	Check the actual amount and flow of cooling air. Check the heatsink for dust. Check the ambient temperature. Make sure that the switching frequency is not too high in relation to ambient temperature and motor load. Check cooling fan.
	131	AC drive over-temperature (alarm, heatsink)		
	132	AC drive over-temperature (fault, board)		
	133	AC drive over-temperature (alarm, board)		
15	140	Motor stall	Motor is stalled.	Check motor and load.
16	150	Motor overtemperature	Motor is overloaded.	Decrease motor load. If no motor overload exists, check the temperature model parameters (parameter Group 3.9: Protections).
17	160	Motor underload	Motor is underloaded.	Check load. Check parameters. Check du/dt and sinus filters.

Fault code	Fault ID	Fault name	Possible cause	Remedy
19	180	Power overload (short-time supervision)	AC drive power is too high.	Decrease load. Check dimensioning of drive. Is it too small for the load?
	181	Power overload (long-time supervision)		
25	240 241	Motor control fault	Appears only in customer specific application, if the feature is in use. Start angle identification has failed. <ul style="list-style-type: none"> <li>• Rotor moves during identification</li> <li>• New identified angle does not match with existing value</li> </ul>	Reset the fault and restart the AC drive. Increase identification current level. See fault history source for more info.
26	250	Start-up prevented	Start-up of the drive has been prevented. Run request is ON when a new software (firmware or application), parameter setting or any other file, which has affects the operation of the drive, has been loaded to drive.	Reset the fault and stop the AC drive. Load the software and start the AC drive.
29	280	Atex thermistor	Atex thermistor has detected the over-temperature	Reset the fault. Check thermistor and its connections.
30	290	Safe Off	Safe Off signal A does not allow AC drive to be set to READY state	Reset the fault and restart the AC drive.
	291	Safe Off	Safe Off signal B does not allow AC drive to be set to READY state	Check the signals from the control board to the power unit and the D connector.
	500	Safety configuration	Appears when the Safety Configuration Switch has been installed	Remove the Safety Configuration Switch from the control board.
	501	Safety configuration	Too many STO option boards have been detected in the drive. Only one is supported.	Remove the extra STO option boards. See Safety manual.
	502	Safety configuration	STO option board has been installed in incorrect slot.	Place the STO option board into correct slot. See Safety manual.
	503	Safety configuration	Safety Configuration Switch is missing from the control board.	Install the Safety Configuration Switch on the control board. See Safety manual.
	504	Safety configuration	Safety Configuration Switch has been installed incorrectly on the control board.	Install the Safety Configuration Switch in correct place on the control board. See Safety manual.
	505	Safety configuration	Safety Configuration Switch on the STO option board has been installed incorrectly.	Check the Safety configuration switch installation on the STO option board. See Safety manual.
	506	Safety configuration	Communication with STO option board has been lost.	Check the installation of STO option board. See Safety manual.
507	Safety configuration	Hardware does not support STO option board	Reset the drive and restart. If the fault reoccurs contact your nearest distributor.	



Fault code	Fault ID	Fault name	Possible cause	Remedy
30	520	Safety diagnostics	Component failure on STO option board	Reset the drive and restart. If the fault reoccurs change the option board.
	521	Safety diagnostics	ATEX thermistor diagnostic fault. ATEX thermistor input connection has failed.	
	522	Safety diagnostics	Short-circuit in ATEX thermistor input connection.	Check ATEX thermistor input connection. Check external ATEX connection. Check external ATEX thermistor.
	530	Safe torque off	Emergency stop button has been connected or some other STO operation has been activated.	When the STO function is activated, the drive is in safe state.
32	311	Fan cooling	Fan speed does not follow the speed reference accurately. However, the AC drive operates properly. This fault appears in MR7 and bigger drives only.	Reset the fault and restart. Clean or change the fan.
	312	Fan cooling	Fan life time (50,000h) is up.	Change fan and reset fan life time counter.
33	320	Fire mode enabled	Fire mode of the drive is enabled. The drive's protections are not in use. <b>NOTE:</b> This alarm is automatically reset when fire mode is disabled.	Check the parameter settings and signals. Some of the driver protections are disabled.
37	361	Device changed (same type)	Power unit has been changed for another of corresponding size. The device is ready to use. Parameters are already available in the drive.	Reset the fault. <b>NOTE!</b> Drive reboots after reset.
	362	Device changed (same type)	Option board in slot B changed for one previously inserted in the same slot. The device is ready to use.	Reset the fault. Old parameter settings will be used.
	363	Device changed (same type)	Same as ID362 but refers to Slot C.	See above.
	364	Device changed (same type)	Same as ID362 but refers to Slot D.	See above.
	365	Device changed (same type)	Same as ID362 but refers to Slot E.	See above.
38	372	Device added (same type)	Option board added into slot B. The option board was previously inserted in the same slot. The device is ready to use.	Device is ready for use. Old parameter settings will be used.
	373	Device added (same type)	Same as ID372 but refers to Slot C.	See above.
	374	Device added (same type)	Same as ID372 but refers to Slot D.	See above.
	375	Device added (same type)	Same as ID372 but refers to Slot E.	See above.

Fault code	Fault ID	Fault name	Possible cause	Remedy
39	382	Device removed	Option board removed from slot A or B.	Device no longer available. Reset the fault.
	383	Device removed	Same as ID380 but refers to Slot C	
	384	Device removed	Same as ID380 but refers to Slot D	
	385	Device removed	Same as ID380 but refers to Slot E	
40	390	Device unknown	Unknown device connected (power unit/option board)	Device no longer available. If the fault reoccurs contact your nearest distributor.
41	400	IGBT temperature	Calculated IGBT temperature is too high. <ul style="list-style-type: none"> <li>• Too high a motor load</li> <li>• Ambient temperature too high</li> <li>• Hardware failure</li> </ul>	Check parameter settings. Check actual amount and flow of cooling air. Check ambient temperature. Check heatsink for dust. Make sure that switching frequency is not too high in relation to ambient temperature and motor load. Check cooling fan. Make identification run.
44	431	Device changed (different type)	Different type of power unit changed. Parameters are not available in the settings.	Reset the fault. <b>NOTE!</b> Drive reboots after the reset. Set power unit parameters again.
	433	Device changed (different type)	Option board in slot C changed for one not present in the same slot before. No parameter settings are saved.	Reset the fault. Set option board parameters again.
	434	Device changed (different type)	Same as ID433 but refers to Slot D.	See above.
	435	Device changed (different type)	Same as ID433 but refers to Slot D.	See above.
45	441	Device added (different type)	Different type of power unit added. Parameters are not available in the settings.	Reset the fault. <b>NOTE!</b> Drive reboots after the reset. Set power unit parameters again.
	443	Device added (different type)	Option board not present in the same slot before added in slot C. No parameter settings are saved.	Set option board parameters again.
	444	Device added (different type)	Same as ID443 but refers to Slot D.	See above.
	445	Device added (different type)	Same as ID443 but refers to Slot E.	See above.
46	662	Real Time Clock	RTC battery voltage level is low and the battery should be changed.	Replace the battery.
47	663	Software updated	Software of the drive has been updated (either the whole software package or application).	No actions needed.

Fault code	Fault ID	Fault name	Possible cause	Remedy
50	1050	AI low fault	At least one of the available analogue input signals has gone below 50% of the defined minimum signal range. Control cable is broken or loose. Signal source has failed.	Change the failed parts. Check the analog input circuit. Check that parameter <i>AI1 signal range</i> is set correctly.
51	1051	Device external fault	Digital input signal defined by parameter P3.5.1.11 or P3.5.1.12 has been activated to indicate the fault situation in external device.	User-defined fault. Check digital inputs/schematics.
52	1052 1352	Keypad communication fault	The connection between the control keypad and AC drive is broken	Check keypad connection and possible keypad cable
53	1053	Fieldbus communication fault	The data connection between the fieldbus master and fieldbus board is broken	Check installation and fieldbus master.
54	1354	Slot A fault	Defective option board or slot	Check board and slot. Contact your nearest distributor.
	1454	Slot B fault		
	1554	Slot C fault		
	1654	Slot D fault		
	1754	Slot E fault		
57	1057	Identification	Identification run has failed.	Check that motor is connected to the drive. Ensure that there is no load on the motor shaft. Ensure that the start command will not be removed before completion of identification run.
58	1058	Mechanical brake	Actual status of mechanical brake remains different from the control signal for longer than what is defined with P3.20.6.	Check the status and connections of the mechanical brake. See parameter P3.5.1.44 (ID1210) and parameter Group 3.20: Mechanical brake.
63	1063	Quick Stop fault	Quick stop activated	Check reason for quick stop activation. Once found and corrective actions taken, reset the fault and restart the drive. See parameter P3.5.1.26 and parameter group 3.4.22.5.
	1363	Quick Stop alarm	Quick stop activated	
65	1065	PC communication fault	The data connection between the PC and AC drive is broken	Check the installation, cable and terminals between the PC and the AC drive.
66	1366	Thermistor input 1 fault	The thermistor input has detected an increase of motor temperature	Check motor cooling and load. Check thermistor connection. If thermistor input is not in use it has to be short circuited. Contact your nearest distributor.
	1466	Thermistor input 2 fault		
	1566	Thermistor input 3 fault		

Fault code	Fault ID	Fault name	Possible cause	Remedy
68	1301	Maintenance counter 1 alarm	Maintenance counter has reached the alarm limit.	Carry out the needed maintenance and reset counter. See parameters B3.16.4 or P3.5.1.40.
	1302	Maintenance counter 1 fault	Maintenance counter has reached the fault limit.	
	1303	Maintenance counter 2 alarm	Maintenance counter has reached the alarm limit.	
	1304	Maintenance counter 2 fault	Maintenance counter has reached the alarm limit.	
69	1310	Fieldbus communication fault	Non-existing ID number is used for mapping values to Fieldbus Process Data Out.	Check parameters in Fieldbus Data Mapping menu (chapter 3.4.19).
	1311		Not possible to convert one or more values for Fieldbus Process Data Out.	The value being mapped may be of undefined type. Check parameters in Fieldbus Data-Mapping menu (chapter 3.4.19).
	1312		Overflow when mapping and converting values for Fieldbus Process Data Out (16-bit).	Check parameters in Fieldbus Data Mapping menu (chapter 3.4.19).
76	1076	Start prevented	Start command is active and was blocked in order to prevent unintentional rotation of the motor during the first power-up.	Reset drive to restore the normal operation. The need of restart depends on the parameter settings.
77	1077	>5 connections	Maximum number of 5 simultaneous active fieldbus or PC tool connections supported by the application exceeded.	Remove excessive active connections.
100	1100	Soft fill timeout	The Soft fill function in the PID controller has timed out. The desired process value was not achieved within this time.	Reason might be a pipe burst. Check the process. Check the parameters in the Soft fill menu M3.13.8.
101	1101	Feedback supervision fault (PID1)	PID controller: Feedback value has gone beyond supervision limits (P3.13.6.2, P3.13.6.3) and the delay (P3.13.6.4) if set.	Check the process. Check parameter settings, supervision limits and delay.
105	1105	Feedback supervision fault (Ext-PID)	External PID controller: Feedback value has gone outside supervision limits (P3.14.4.2, P3.14.4.3) and the delay (P3.14.4.4) if set.	Check the process. Check parameter settings, supervision limits and delay.
109	1109	Input pressure supervision	Input pressure supervision signal (P3.13.9.2) has gone below the alarm limit (P3.13.9.7) .	Check the process. Check the parameters in menu M3.13.9.
	1409		Input pressure supervision signal (P3.13.9.2) has gone below the fault limit (P3.13.9.8) .	Check the input pressure sensor and connections.

Fault code	Fault ID	Fault name	Possible cause	Remedy
111	1315	Temperature fault 1	At least one of the selected temperature input signals (P3.9.6.1) has reached the alarm limit (P3.9.6.2).	Find the cause of temperature raise. Check the temperature sensor and connections. Check that the temperature input is hardwired if no sensor is connected. See option board manual for further information.
	1316		At least one of the selected temperature input signals (P3.9.6.1) has reached the fault limit (P3.9.6.3).	
112	1317	Temperature fault 2	At least one of the selected temperature input signals (P3.9.6.5) has reached the fault limit (P3.9.6.6).	
	1318		At least one of the selected temperature input signals (P3.9.6.5) has reached the fault limit (P3.9.6.7).	
300	700	Unsupported	Unsupported application used.	Change the application
	701		Unsupported option board or slot used.	Remove the option board

Table 137. Fault codes and descriptions

# VACON

DRIVEN BY DRIVES

Find your nearest Vacon office  
on the Internet at:

[www.vacon.com](http://www.vacon.com)

Document ID:



Order code:



Manual authoring:  
[documentation@vacon.com](mailto:documentation@vacon.com)

Vacon Plc.  
Runsorintie 7  
65380 Vaasa  
Finland

Subject to change without prior notice  
© 2012 Vacon Plc.

Rev. D