

VACON 100
AC DRIVES

OPTBJ
STO AND ATEX OPTION BOARD
SAFETY MANUAL

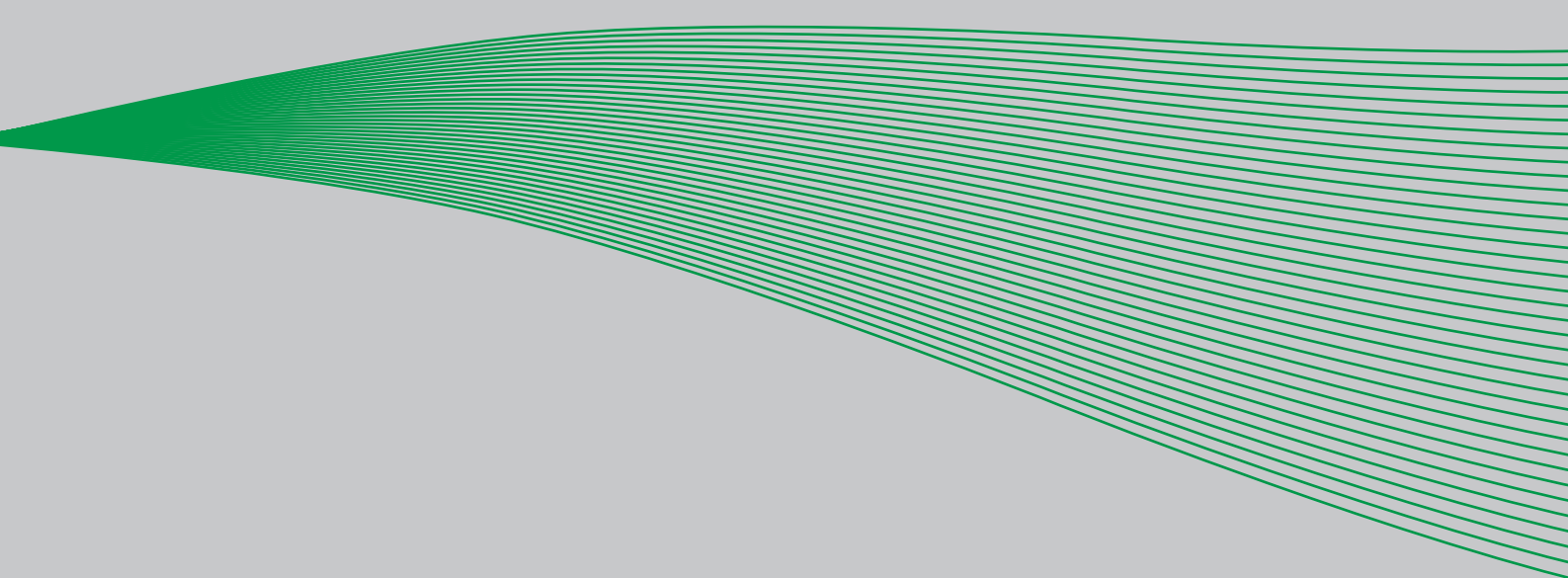

Table of contents

1. General 9
 1.1 References 10

2. Installation of OPTBJ board 11

3. OPTBJ board layout 14
 3.1 OPTBJ board jumpers 14
 3.2 STO jumpers on the Vacon 100 drive 15

4. STO and SS1 safety functions 16
 4.1 Safe Torque Off (STO) principle 17
 4.2 Safe Stop 1 (SS1) Principle 18
 4.3 Technical details 20
 4.3.1 Response times 20
 4.3.2 Connections 20
 4.3.3 Relay output 21
 4.3.4 Safety-related data according to the standard 21
 4.3.5 Wiring examples 23

5. Commissioning 26
 5.1 General wiring instructions 26
 5.2 Checklist for commissioning the OPTBJ board 27
 5.3 Testing the Safe Torque Off (STO) or Safe Stop 1 (SS1) safety functions 28

6. Maintenance 29
 6.1 Faults related to the Safe Torque Off (STO) or Safe Stop 1 (SS1) safety functions .. 29

7. Thermistor function (ATEX) 31
 7.1 Technical data 33
 7.1.1 Functional description 33
 7.1.2 Hardware and connections 33
 7.1.3 Atex function 33
 7.1.4 Short circuit monitoring 34
 7.2 Commissioning 35
 7.2.1 General wiring instructions 35
 7.2.2 Fault diagnosis of thermistor function 35



EC DECLARATION OF CONFORMITY

Manufacturer's name: Vacon Plc
Manufacturer's address: P.O.Box 25
 Runsorintie 7
 FIN-65381 Vaasa
 Finland

We hereby declare that the safety functions of the following product

Product name: Vacon OPTBJ option board to be used with Vacon 100 family products
Product Identification 70CVB01380
Product Safety Functions Safe Torque Off (Specified in EN 61800-5-2)

fulfils all of the relevant safety component requirements of EC Machinery Directive 2006/42/EC.

Person authorized to compile the technical file: Jussi Veikkolainen

Notified body that carried out the EC type examination:

TÜV Rheinland Industrie Service GmbH (NB0035)
 Am Grauen Stein
 51105 Köln, Germany

The following standards and/or technical specifications referenced below were used:

EN 61800-5-2:2007

Adjustable speed electrical power drive systems
 Part 5-2: Safety requirements - Functional

EN 61800-5-1:2007 (only for LV Directive compliance)

Adjustable speed electrical power drive systems
 Part 5-2: Safety requirements - Electrical, thermal and energy

EN 61800-3:2004 (only for EMC Directive compliance)

Adjustable speed electrical power drive systems
 Part 3: EMC requirements and specific test methods

EN ISO 13849-1:2008 + AC:2009

Safety of machinery - Safety-related parts of control systems -
 Part 1: General principles for design

EN 62061:2005 + AC:2010

Safety of machinery - Functional safety of safety-related electrical, electronic and programmable electronic control systems

IEC 61508 Parts 1-7:2010

Functional safety of electrical/electronic/programmable electronic safety-related systems

EN 60204-1:2006 + A1:2009 + AC:2010 (in extracts)

Safety of machinery -
 Electrical equipment of machines -
 Part 1: General requirements

Signature

In Vaasa, 4th of May, 2012

Vesa Laisi
 President and CEO

Authorised representative

Jussi Veikkolainen
 Functional Safety Manager

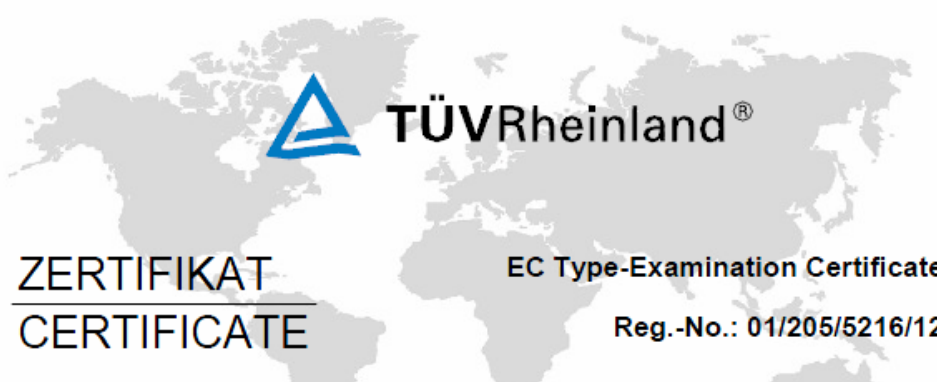

**ZERTIFIKAT
CERTIFICATE**

EC Type-Examination Certificate

Reg.-No.: 01/205/5216/12

Product tested	Safety Function "Safe Torque Off (STO)" within Adjustable Frequency AC Drive	Certificate holder	Vacon PLC Runsorintie 7 65380 Vaasa Finland
Type designation	Vacon 100 AC Drive with OPTBJ (STO and ATEX option board): Frame Sizes MR4 to MR9, VACON 0100-3L-xxxx-2, (208—240 V, 50/60 Hz, 3~), VACON 0100-3L-xxxx-5, (380—500 V, 50/60 Hz, 3~)	Manufacturer	see certificate holder
Codes and standards forming the basis of testing	EN 61800-5-2:2007 EN 61800-5-1:2007 EN 61800-3:2004 EN ISO 13849-1:2008 + AC:2009	EN 62061:2005 + AC:2010 EN 61508 Parts 1-7:2010 EN 60204-1:2006 + A1:2009 + AC:2010 (in extracts)	
Intended application	The safety function "Safe Torque Off" complies with the requirements of the relevant standards (PL e acc. to EN ISO 13849-1, SIL CL 3 acc. to EN 61800-5-2 / EN 62061 / IEC 61508) and can be used in applications up to PL e acc. to EN ISO 13849-1 and SIL 3 acc. to EN 62061 / IEC 61508.		
Specific requirements	The instructions of the associated Installation and Operating Manual shall be considered.		
It is confirmed that the product under test complies with the requirements for machines defined in Annex I of the EC Directive 2006/42/EC.			
This certificate is valid until 2017-05-04.			

The test report-no.: 968/M 350.00/12 dated 2012-05-04 is an integral part of this certificate.

This certificate is valid only for products which are identical with the product tested. It becomes invalid at any change of the codes and standards forming the basis of testing for the intended application.

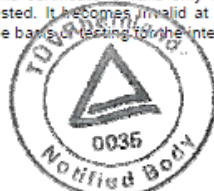

Berlin, 2012-05-04

Certification Body for Machinery, NB 0035

Dipl.-Ing. Eberhard Frejno

TÜV Rheinland Industrie Service GmbH, Altonstr. 56, 12103 Berlin / Germany
Tel: +49 30 7562-1557, Fax: +49 30 7562-1370, E-Mail: tuvr@de.tuv.com



1. **EC-TYPE EXAMINATION CERTIFICATE**
2. **Equipment or Protective System Intended for use in
Potentially explosive atmospheres
Directive 94/9/EC**
3. Reference: **VTT 06 ATEX 048X Issue 1**
4. Equipment: **Thermal motor protection system for Vacon 100
drives**
 Certified types: **OPTBJ**
5. Manufactured by: **Vacon Plc**
6. Address: **Runsorintie 7
FI-65380 VAASA
Finland**
7. This equipment or protective system and any acceptable variations thereto are specified in the schedule and possible supplement(s) to this Certificate and the documents therein referred to.
8. VTT Expert Services Ltd, notified body number 0537, in accordance with Article 9 of the Council Directive 94/9/EC of March 1994, certifies that this equipment or protective system has been found to comply with the Essential Health and Safety Requirements relating to the design and construction of equipment and protective system intended for use in potentially explosive atmospheres given in Annex II to the Directive

 The examination and test results are recorded in confidential reports nos. VTT-S-05774-06 and 968/M 350.00/12 by TÜV Rheinland Industrie Service GmbH.



9. Compliance with the Essential Health and Safety Requirements has been assured by compliance with:
- EN ISO 13849-1 (2006)**
EN ISO 13849-2 (2003)
EN 60079-14 (2007)
EN 61508-3 (2010)
EN 50495 (2010)
10. If the sign "X" is placed after the certificate number, it indicates that the equipment or protective system is subject to special conditions for safe use specified in the schedule to this certificate.
11. This EC-Type examination certificate relates only to the design, examination and tests of the specified equipment or protective system in accordance to the directive 94/9/EC. Further requirements of the Directive apply to the manufacturing process and supply of this equipment or protective system. These are not covered by this certificate.
12. The marking of the equipment or protective system shall include the following:



II (2) GD

Espoo 26.4.2012

VTT Expert Services Ltd

Olavi Nevalainen
Deputy Service Manager

Risto Sulonen
Product Manager

Certificate without signatures shall not be valid.
This certificate, including the schedule, may only be reproduced in its entirety and without any change.

13. **Schedule**

14. **EC-TYPE EXAMINATION CERTIFICATE VTT 06 ATEX 048X Issue 1**

15. Description of Equipment

Thermal motor protection system, type OPTBJ, consist one safe disable & ATEX option board with possibility to connect to temperature sensor (PTC). The temperature sensor is not included in this certificate. The ATEX safety function may be used with all Vacon 100 drives that are controlled with the M-platform STO option board.

Documents specifying the equipment:

Functional safety management plan for the M-Platform STO, rev 1.3.

16. Report No. VTT-S-05774-06 and 968/M 350.00/12 by TÜV Rheinland Industrie Service GmbH.

17. Special conditions for safe use

1. In the case of Exe- and ExnA-motors, the end user has to confirm that the installation of measurement circuit is installed according to area classification. E.g. in Exe- and ExnA-motors PTC-sensors shall be certified together with the motor according to requirements of the type of protection.
2. The allowed ambient temperature range is -10°C...+50°C.

18. Essential Health and Safety Requirements

Assessment using standards referred in point 9 have confirmed compliance with the Directive 94/9/EC, Annex II and in particular point 1.5. The device themselves are to be installed outside potentially explosive atmospheres (article 1, section 2 of the Directive).

Certificate without signatures shall not be valid.
This certificate, including the schedule, may only be reproduced in its entirety and without any change.

Certificate history

Issue	Date	Report No.	Comment
-	19.6.2006	VTT-S-05774-06	Prime certificate
Supplement 1 and 2	26.6.2008 and 6.4.2010		The introduction of new revisions and STO function
1	26.4.2012	968/M 350.00/12	The introduction of M-Platform STO-function and changing equipment name and type designation. Updating the certificate with the latest edition of relevant standards

Espoo 26.4.2012

VTT Expert Services Ltd

 Olavi Nevalainen
 Deputy Service Manager



 Risto Sulonen
 Product Manager

 Certificate without signatures shall not be valid.

This certificate, including the schedule, may only be reproduced in its entirety and without any change.

1. GENERAL

NOTE! These are the original instructions.

NOTE! Designing of safety-related systems requires special knowledge and skills. Only qualified persons are permitted to install and set up the OPTBJ board.

This document covers OPTBJ option board 70CVB01380 functionality together with Vacon 100 Control board 70CVB01582.

The OPTBJ option board together with Vacon 100 control board provides the following safety functions with Vacon 100 products.

The following safety-related abbreviations and expressions have been used in this manual:

SIL	Safety Integrity Level
PL	Performance Level
PFH	Probability of a dangerous random hardware Failure per Hour
Category	Designated architecture for a safety function (from EN ISO 13849-1:2006)
MTTF_d	Mean time to dangerous failure
DC_{avg}	Average diagnostic coverage
PFD_{avg}	Average probability of (random hardware) failure on demand
T_M	Mission time

Safe Torque Off (STO)

Hardware based 'Safe Torque Off' safety function to prevent the drive from generating torque on the motor shaft. STO safety function has been designed for use in accordance with the following standards:

- EN 61800-5-2 Safe Torque Off (STO) SIL3
- EN ISO 13849-1 PL"e" Category 3
- EN 62061: SILCL3
- IEC 61508: SIL3
- The function also corresponds to an uncontrolled stop in accordance with stop category 0, EN 60204-1.
- The STO safety function has been certified by TÜV Rheinland *

NOTE! The STO function is not the same as a prevention of unexpected start-up function. For fulfilling those requirements, additional external components are required according to appropriate standards and application requirements. Required external components may be for example:

- Appropriate lockable switch
- A safety relay providing a reset function

NOTE! The safety functions of OPTBJ do not comply with Emergency Switching Off according to EN 60204-1.

NOTE! The STO function shall not be used as a standard stop function of the drive.

NOTE! The shaft of a permanent magnet motor might in an IGBT fault situation rotate up to 180 degrees / pole of the motor.

NOTE! If pollution degree 2 cannot be guaranteed, IP54 protection class shall be used.

CAUTION! The OPTBJ board and its safety functions do not electrically isolate the drive output from the mains supply. If electrical work is to be carried out on the drive, the motor or the motor cabling, the drive has to be completely isolated from the mains supply e.g. using an external supply disconnecting switch. See for e.g. EN60204-1 section 5.3.

Safe Stop 1 (SS1)

SS1 safety function is realized in compliance with type C of the drives safety standard EN 61800-5-2 (Type C: "The PDS(SR) initiates the motor deceleration and initiates the STO function after an application specific time delay")

SS1 safety function has been designed for use in accordance with the following standards:

- EN 61800-5-2 Safe Stop 1 (SS1) SIL2
- EN ISO 13849-1 PL"d" Category 3
- EN 62061: SILCL2
- IEC 61508: SIL2
- The function also corresponds to a controlled stop in accordance with stop cat. 1, EN 60204-1.

* TÜV Rheinland = International product testing institute

Motor Thermistor Over temperature protection (according to ATEX)

Overtemperature detection using thermistor. It can be used as a tripping device for ATEX certified motors.

The thermistor tripping function is certified by VTT** according to ATEX directive 94/9/EC.

All safety functions of the OPTBJ board are described in this user's manual.

** VTT = Technical Research Centre of Finland

1.1 REFERENCES

Vacon 100 Installation and Application manuals are downloadable at www.vacon.com -> Support & downloads -> Vacon manuals -> Vacon 100 manuals.

2. INSTALLATION OF OPTBJ BOARD

1

Open the cover of the AC drive.

M4x55



The relay outputs and other I/O-terminals may have a dangerous control voltage present even when Vacon 100 is disconnected from mains.

2

Slot coding

3040.emf

NOTE: Incompatible boards cannot be installed on Vacon 100. Compatible boards have a slot coding that enable the placing of the board (see above)

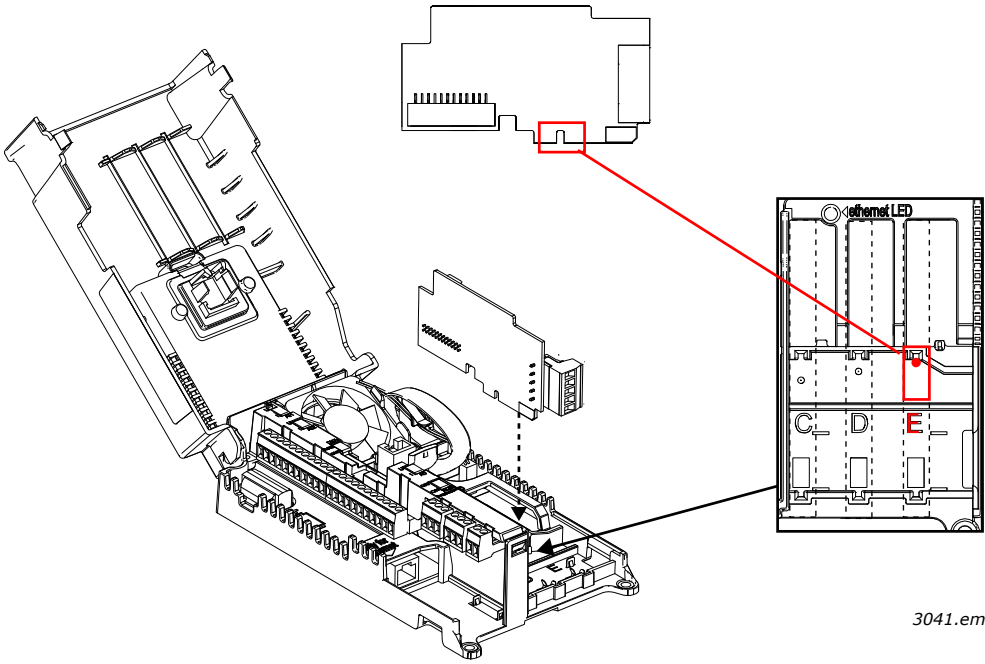
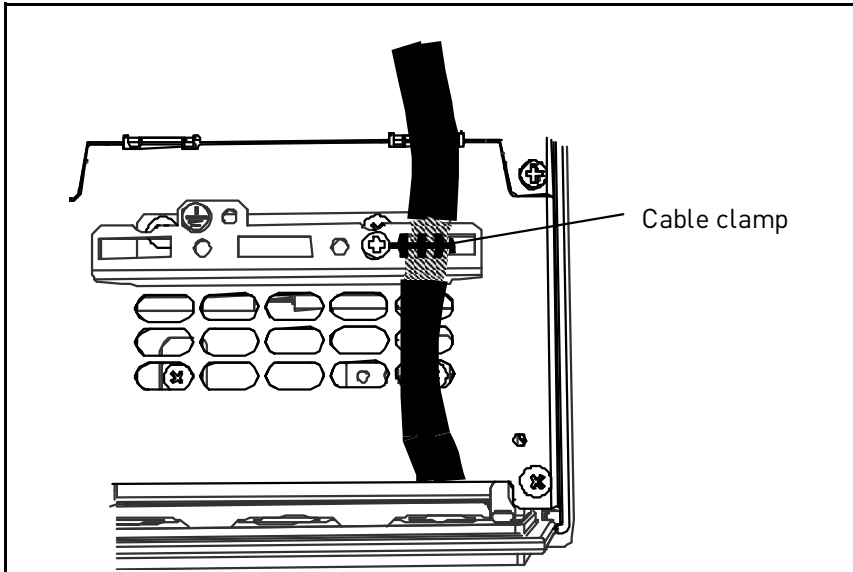
<p>3</p>	<p>Open the inner cover to reveal the option board slots and install the OPTBJ board into slot E. Close the inner cover. See Figure below: NOTE! See chapter 3.1 for the jumper settings!</p>  <p style="text-align: right;"><i>3041.emf</i></p>
<p>4</p>	<p>Using the cable clamp included in the delivery of the drive, ground the shield of the OPTBJ cable to the frame of the AC drive. NOTE! Shielded cable must be used. NOTE! Grounding must be done according to best practice.</p>  <p style="text-align: right;">Cable clamp</p>

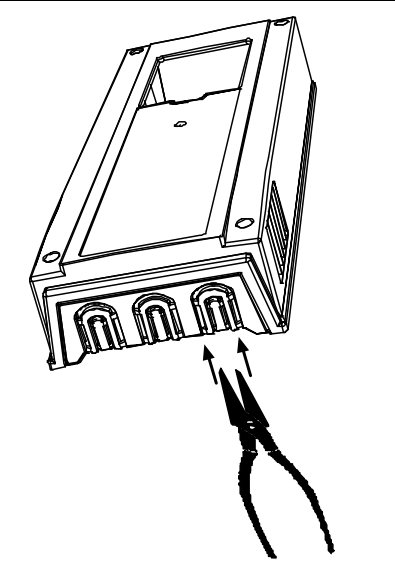
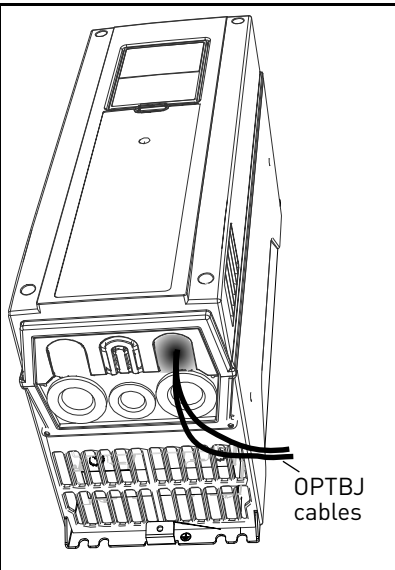
<p>5</p>	<p>Unless already done for the other control cables, cut free the opening on the AC drive cover for the OPTBJ cable (protection class IP21). NOTE: Cut the opening on the side of the slot E!</p>	
<p>6</p>	<p>Remount the AC drive cover and run the cable as shown in picture. NOTE: When planning the cable runs, remember to keep the distance between OPTBJ cables and the motor cable at a minimum of 30 cm. It is recommended to route the OPTBJ cables away from the power cables as shown in the picture</p>	

3. OPTBJ BOARD LAYOUT

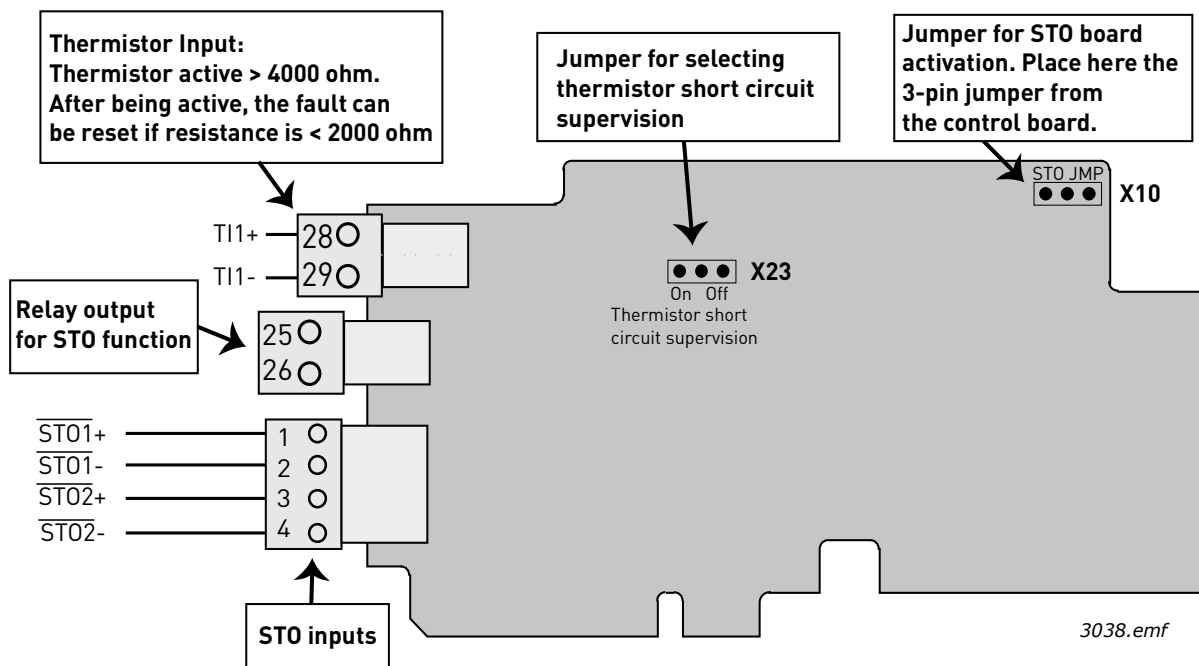

Figure 1. OPTBJ board layout

3.1 OPTBJ BOARD JUMPERS

There are two jumpers on the OPTBJ option board. The jumpers are described below:

Jumper X23, short circuit supervision

- Short circuit supervision ON
- Short circuit supervision OFF

Jumper X10, STO board activation

- STO board not activated
- STO board activated, take the 3-pin jumper from the control board, see figure below:

= Factory default

3039.emf

Figure 2. OPTBJ board jumpers

To activate the OPTBJ board, you must take the three-pin jumper from the drive control board and place it to the OPTBJ board jumper X10. See the next chapter for more information.

NOTE! If there are problems with the jumpers, see chapter 6.1!

3.2 ST0 JUMPERS ON THE VACON 100 DRIVE

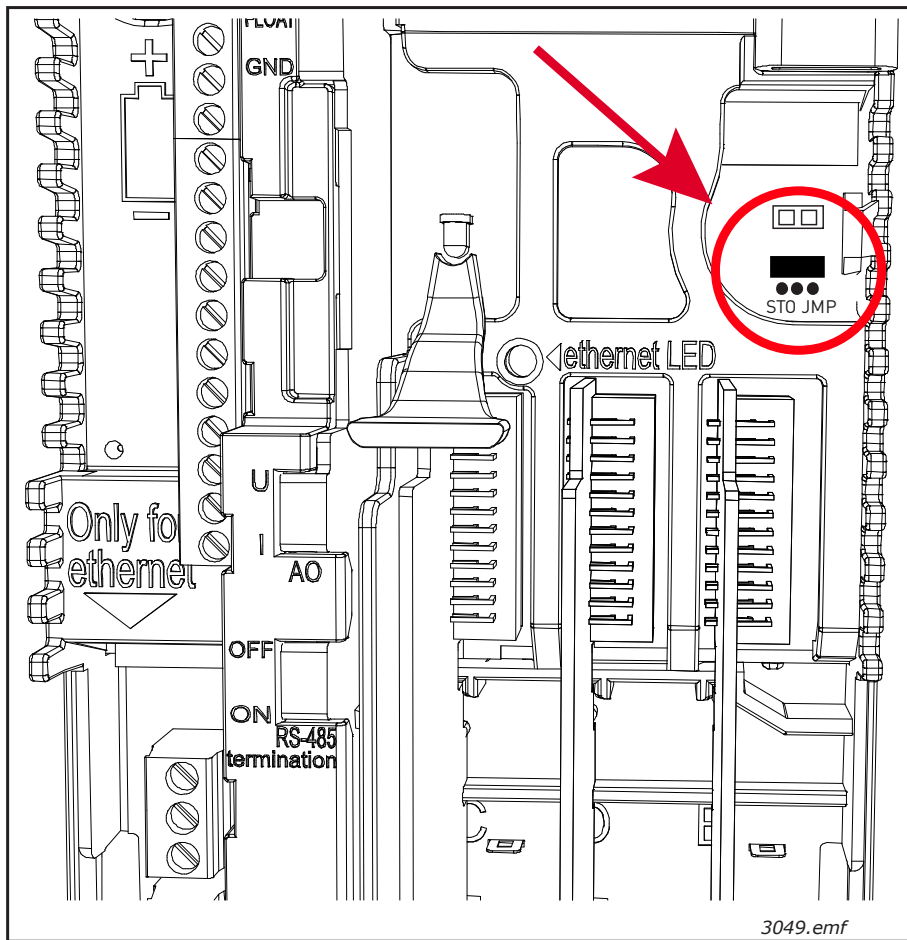

Figure 3. STO jumper location on Vacon 100. Open the main cover and the inner cover to reveal the jumper.

4. STO AND SS1 SAFETY FUNCTIONS

The safety functions of the OPTBJ board, such as the technical principle and data, wiring examples and commissioning, will be described in this chapter.



NOTE! The use of STO, SS1 or other safety functions does not itself ensure safety. An overall risk evaluation is required in order to make sure that the commissioned system is safe. Safety devices like the OPTBJ board must be correctly incorporated into the entire system. The entire system must be designed in compliance with all relevant standards within the field of industry.

Standards such as EN12100 Part 1, Part 2, & ISO 14121-1 provide methods for designing safe machinery and for carrying out a risk assessment.



CAUTION! The information in this manual provides guidance on the use of the safety functions that OPTBJ option board provides together with Vacon 100 control board. This information is in compliance with accepted practice and regulations at the time of writing. However, the end product/system designer is responsible for ensuring that the system is safe and in compliance with relevant regulations.

4.1 SAFE TORQUE OFF (STO) PRINCIPLE

The STO safety function of the OPTBJ board allows the drive output to be disabled so that the drive cannot generate torque in the motor shaft. For STO, the OPTBJ board has two separate, galvanically isolated inputs STO1 and STO2.

NOTE! The STO inputs must be connected to +24V signal for the drive to be able to go to enable state.

The STO safety function is achieved by disabling the drive modulation. The drive modulation is disabled through two independent paths controlled by STO1 and STO2 so that a single fault in any of the safety related parts will not lead to the loss of the safety function. This is done by disabling the gate driver signal outputs to the driver electronics. The gate drive output signals control the IGBT module. When gate drive output signals are disabled, the drive will not generate torque in the motor shaft. See Figure below.

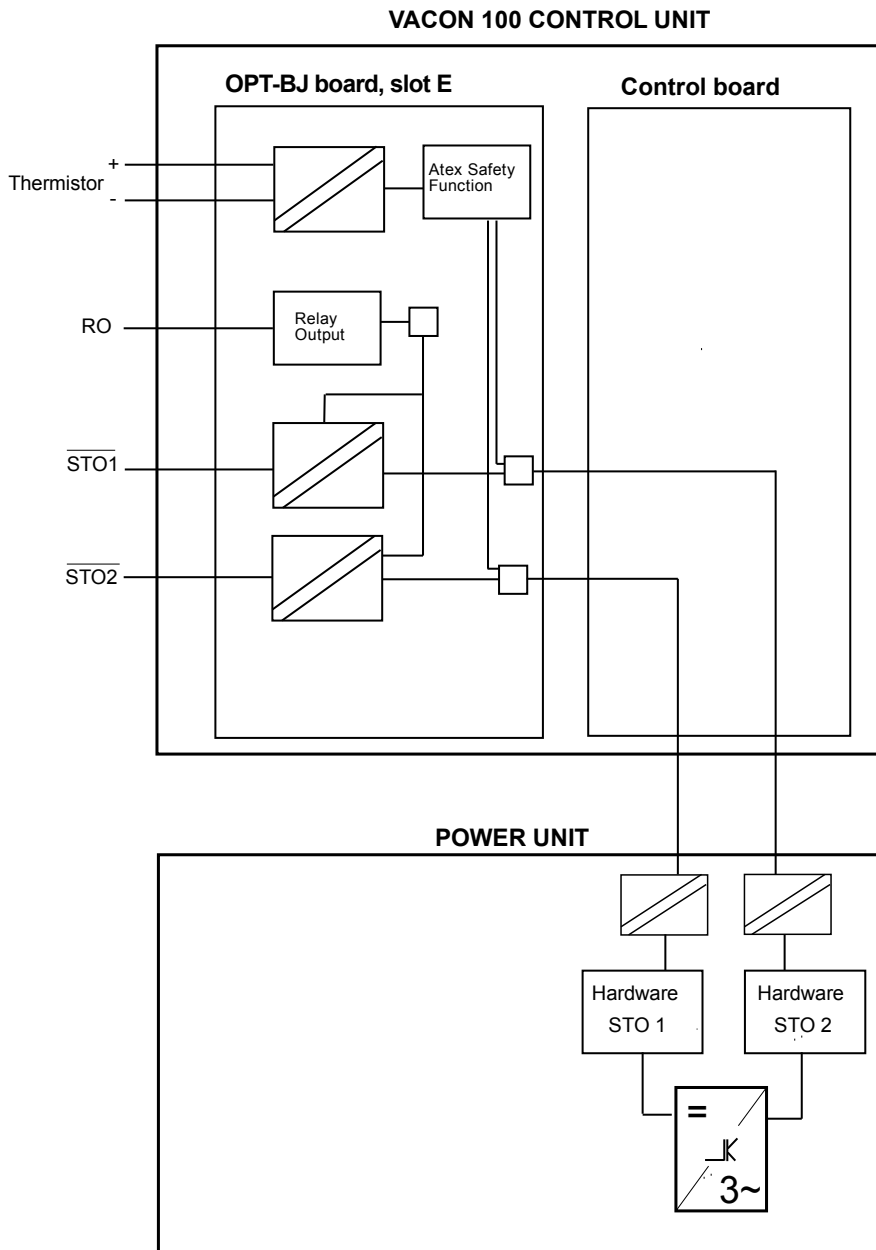

Figure 4. STO principle with OPTBJ board and Vacon 100 control board

4.2 SAFE STOP 1 (SS1) PRINCIPLE

After a safe stop command the motor starts decelerating and SS1 safety function initiates the STO after a user set time delay.

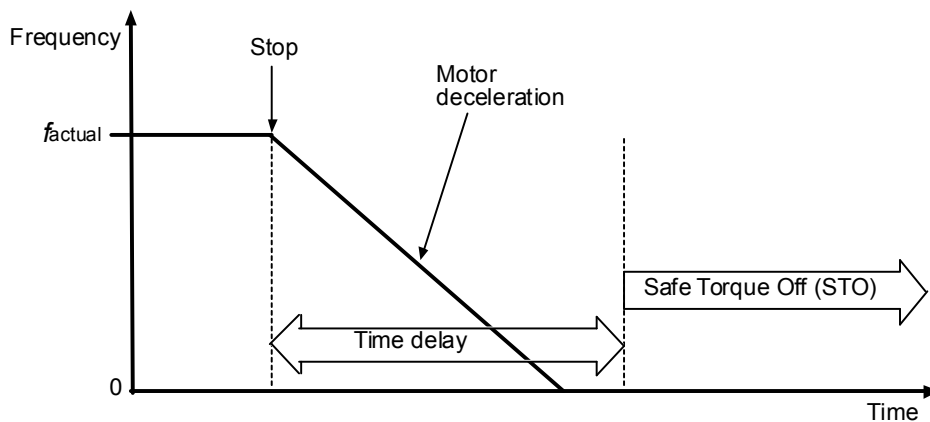

Figure 5. The principle of Safe Stop 1 (EN 61800-5-2, SS1 type c)

The Safe Stop 1 (SS1) safety function consists of two safety related subsystems, an external time delayed safety relay and the STO safety function. These two subsystems combined compose the Safe Stop 1 safety function as shown in Figure 6.

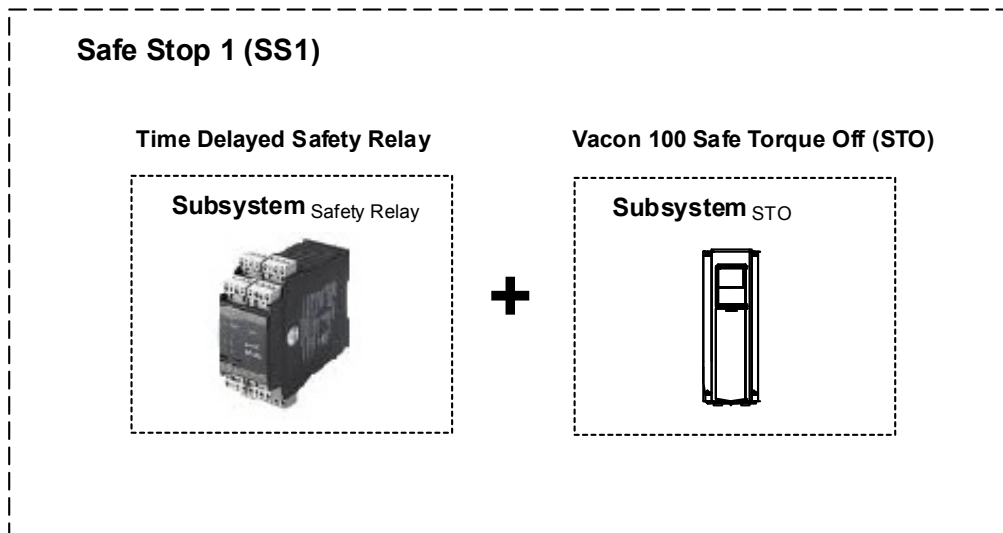

Figure 6. Safe Stop 1 (SS1) safety function

Figure 7 shows the connection principle of Safe Stop 1 safety function, as specified in figure 5.

- The time delayed safety relay outputs are connected to the STO inputs.
- A separate digital output from the safety relay is connected to a general digital input of the Vacon 100 drive. The general digital input must be programmed to execute the drive stop command and initiates without time delay the drive stop function (must be set to "stop by ramp") and causes motor deceleration. If the SS1 behavior of Figure 5 is required then it must be ensured that the ramp stop is activated when the stop signal is received. It is the responsibility of the system designer to verify this.

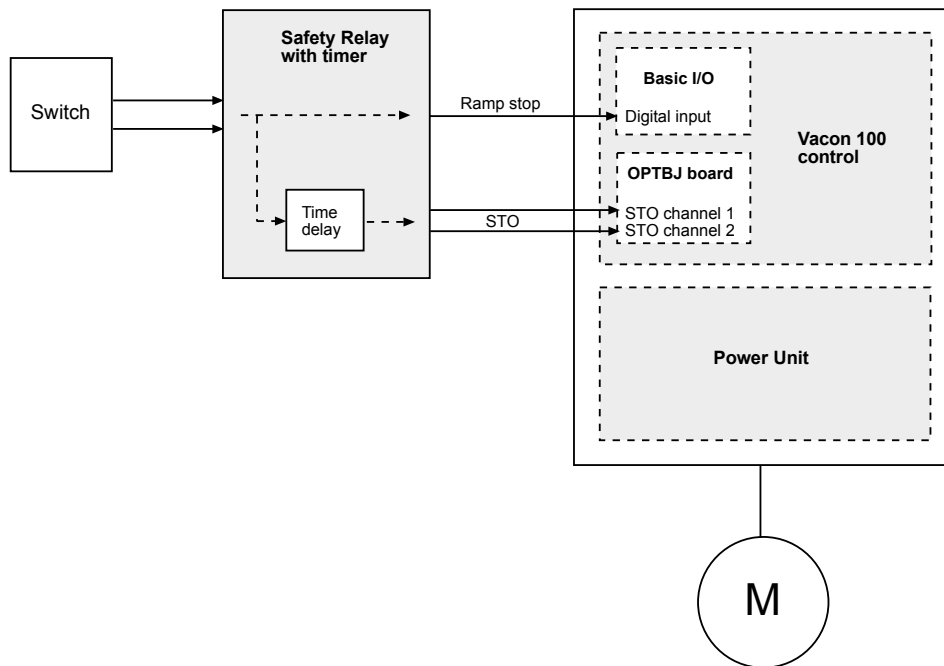

Figure 7. The connection principle of Safe Stop 1 (SS1)

CAUTION! The system designer/user is responsible of understanding and setting the time delay of the safety relay, due to the fact it is process/machine dependent.

- The time delay must be set to a greater value than the deceleration time of the drive*. The motor deceleration time is process/machine dependent.
- The stop function of the drive needs to be correctly set for the process/machine. Activating the SS1 safety function must execute the configured stop in the drive. In the Vacon 100 default application software it is recommended to use the "Quick Stop" functionality for this purpose.

CAUTION! The control place must be set according to the application requirements.

See Chapter 5.4 concerning the parametrizing of Safe Stop 1 and Chapter 4.3.5 for the wiring of Safe Stop 1.

* In case of a single fault the drive may not ramp down but is only put to STO mode after the configured time delay.

4.3 TECHNICAL DETAILS

4.3.1 RESPONSE TIMES

Safety function	Activation time	De-activation time
Safe Torque Off (STO)	< 20 ms	500 ms

Table 1. STO response times

4.3.2 CONNECTIONS

In addition to the STO inputs, the board contains also a thermistor input. If the thermistor input is not used it must be disabled. The thermistor input is disabled by making a short circuit to the terminals and setting the jumper X23 in "OFF" state. The thermistor input operation and instructions are presented in chapter 7.1.

Terminal	Technical information
1	STO1+
2	STO1-
3	STO2+
4	STO2-
25	R01
26	R02
28	TI1+
29	TI1-

Isolated STO input 1, +24V +-20% 10... 15mA
 Virtual GND 1
 Isolated STO input 2, +24V +-20% 10... 15mA
 Virtual GND 2
 Relay output 1 (NO) *
 Switching capacity:
 • 24VDC/8A
 • 250VAC/8A
 • 125VDC/0.4A
 Min. switching load: 5V/10mA
 Thermistor input; R_{trip} > 4.0 kΩ (PTC)

Table 2. OPTBJ I/O terminals

* If 230VAC is used as control voltage from the output relays, the control circuitry must be powered with a separate isolation transformer to limit short circuit current and overvoltage spikes. This is to prevent the welding on the relay contacts.

V _{STO1+} - V _{STO1-}	V _{STO2+} - V _{STO2-}	STO state
0VDC	0VDC	STO active
24VDC	0VDC	STO diagnostic fault
0VDC	24VDC	STO diagnostic fault
24VDC	24VDC	STO inactive

Table 3. STO function truth table

4.3.3 RELAY OUTPUT

When the STO function is active, the relay output is closed. When the STO function is inactive the relay output is open. When STO function has detected a non-resettable diagnostics fault the relay output toggles at a frequency of one hertz.

NOTE! The ATEX input has no effect on the relay output.

CAUTION! The relay output is intended only for diagnostics of the STO function.

CAUTION! The relay output is a non-safety-related functionality.

4.3.4 SAFETY-RELATED DATA ACCORDING TO THE STANDARD

Safe Torque Off (STO) safety-related data

EN 61800-5-2:2007	SIL 3 PFH = $2,5 \cdot 10^{-10}$ /hour HFT = 1
EN 62061:2005	SIL CL 3 PFH = $2,5 \cdot 10^{-10}$ /hour HFT = 1
EN/ISO 13849-1:2006	PL e MTTF _d = 2600 years DC _{avg} = medium Category 3
IEC 61508:2010, High Demand Mode	SIL 3 PFH = $2,5 \cdot 10^{-10}$ /hour HFT = 1
IEC 61508:2010, Low Demand Mode	SIL 3 PFD _{AVG} (T _M) = $2,2 \cdot 10^{-5}$ T _M = 20 years HFT = 1

Safe Stop (SS1) safety-related data

NOTE! The following chapter is only an informative example of combining products.

The SS1 safety function consists of two subsystems with different safety-related data. The subsystem consisting of the time delayed safety relay is manufactured by e.g. PHOENIX CONTACT. The following types are available from this manufacturer:

- PSR-SCP-24DC/ESD/5X1/1X2/300 or
- PSR-SPP-24DC/ESD/5X1/1X2/300

See manufacturer user manual for more information regarding the time delayed safety relay.

PSR-SC/PP-24DC/ESD/5X1/1X2/300 safety-related data from user manual and certificate:

IEC 61 508	SIL 2
EN 62061	SIL CL 2
DIN EN/ISO 13849-1	PL d Category 3
PFH	$1,89 \cdot 10^{-9}$ /hour

Subsystem_{SafetyRelay}

Vacon 100 STO safety-related data:

EN 61800-5-2	SIL 3
EN 62061	SIL CL 3
IEC 61508	SIL 3
DIN EN/ISO 13849-1	PL e Category 3
PFH	$2,52 \cdot 10^{-10}$ /hour

Subsystem_{Vacon100STO}

+

Safe Stop 1 (SS1) safety-related data:

EN 61800-5-2	SIL 2
EN 62061	SIL CL 2
IEC 61508	SIL 2
DIN EN/ISO 13849-1	PL d Category 3
PFH	$2,14 \cdot 10^{-9}$ /hour

When the two subsystems are combined, the maximum safety integrity level or performance level reached is the level of the lower subsystem.

- SIL 2 and PL d

The PFH value for a safety function of combined subsystems is the sum of all subsystems PFH values.
 $PFH_{SS1} = PFH_{SafetyRelay} + PFH_{VACON100STO} = 1,89 \cdot 10^{-9} /hour + 2,52 \cdot 10^{-10} /hour = 2,14 \cdot 10^{-9} /hour$

- The result is within the requirements for SIL 2 and PL d.

4.3.5 WIRING EXAMPLES

The examples in this chapter show the basic principles for wiring OPTBJ board. Local standards and regulations should be always followed in the final design.

Example 1: OPTBJ board without reset for Safe Torque Off (STO)

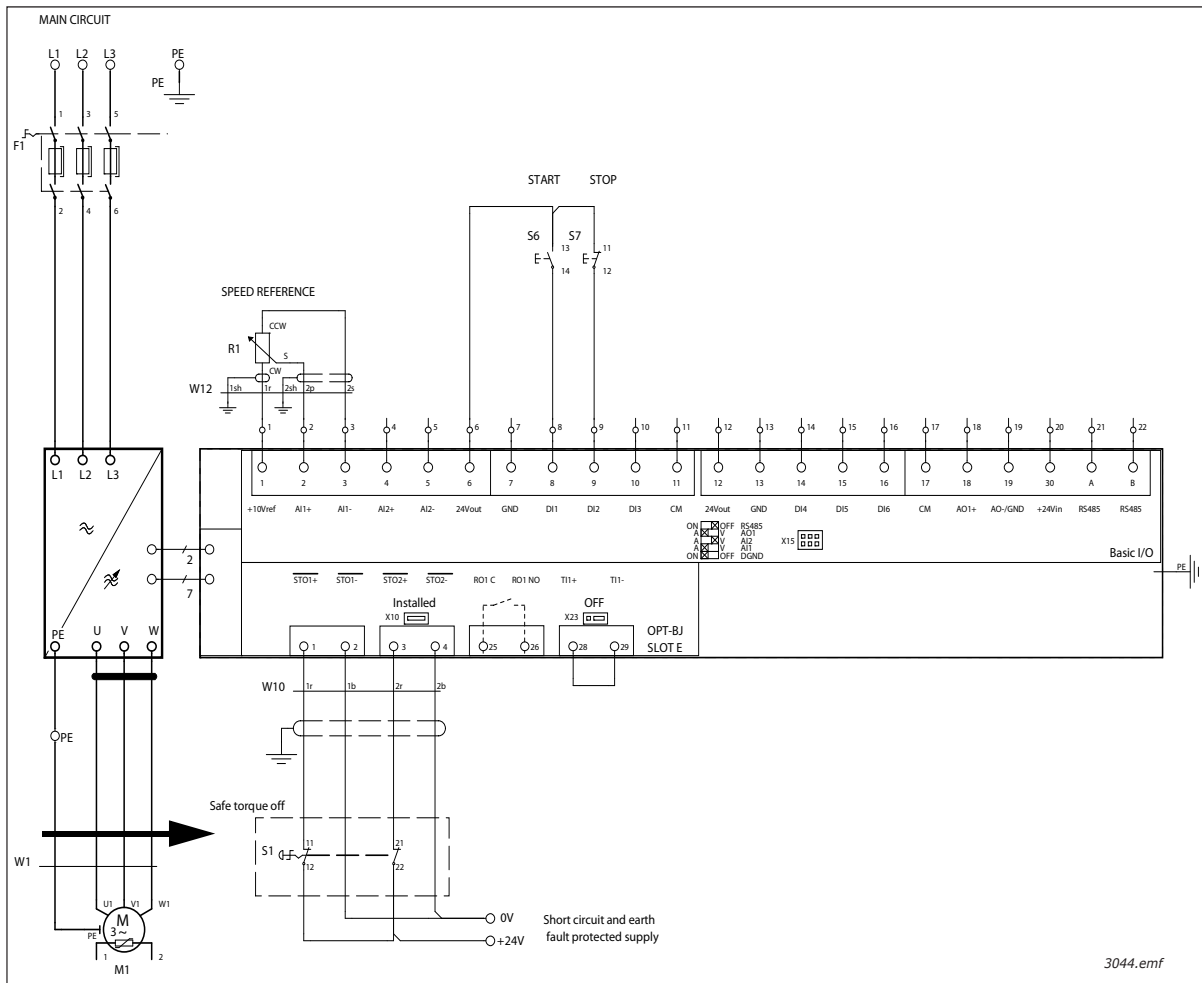

Figure above shows a connection example of OPTBJ board for Safe Torque Off safety function without reset. The switch S1 is connected with 4 wires to the OPTBJ board as shown above.

The power supply to S1 may come from control board (connector pins 6 & 7 in the above Figure) or it may also be external.

When the switch S1 is activated (contacts open), the drive will go to STO state and motor (if running) will stop by coasting. The drive will indicate: "30 SafeTorqueOff".

To start the motor operation again, following sequence is performed.

- Release switch S1 (contacts closed). The hardware is now enabled but the drive continues to display the fault "30 SafeTorqueOff".
- Acknowledge the releasing of switch by edge sensitive reset function. The drive returns to the ready state.
- Giving a valid start command will start running the motor.

Note: The Vacon 100 default application software uses edge-sensitive start as default start command, for preventing unexpected startup from STO state.

Example 2: OPTBJ board with reset for Safe Torque Off or EN 60204-1 stop category 0.

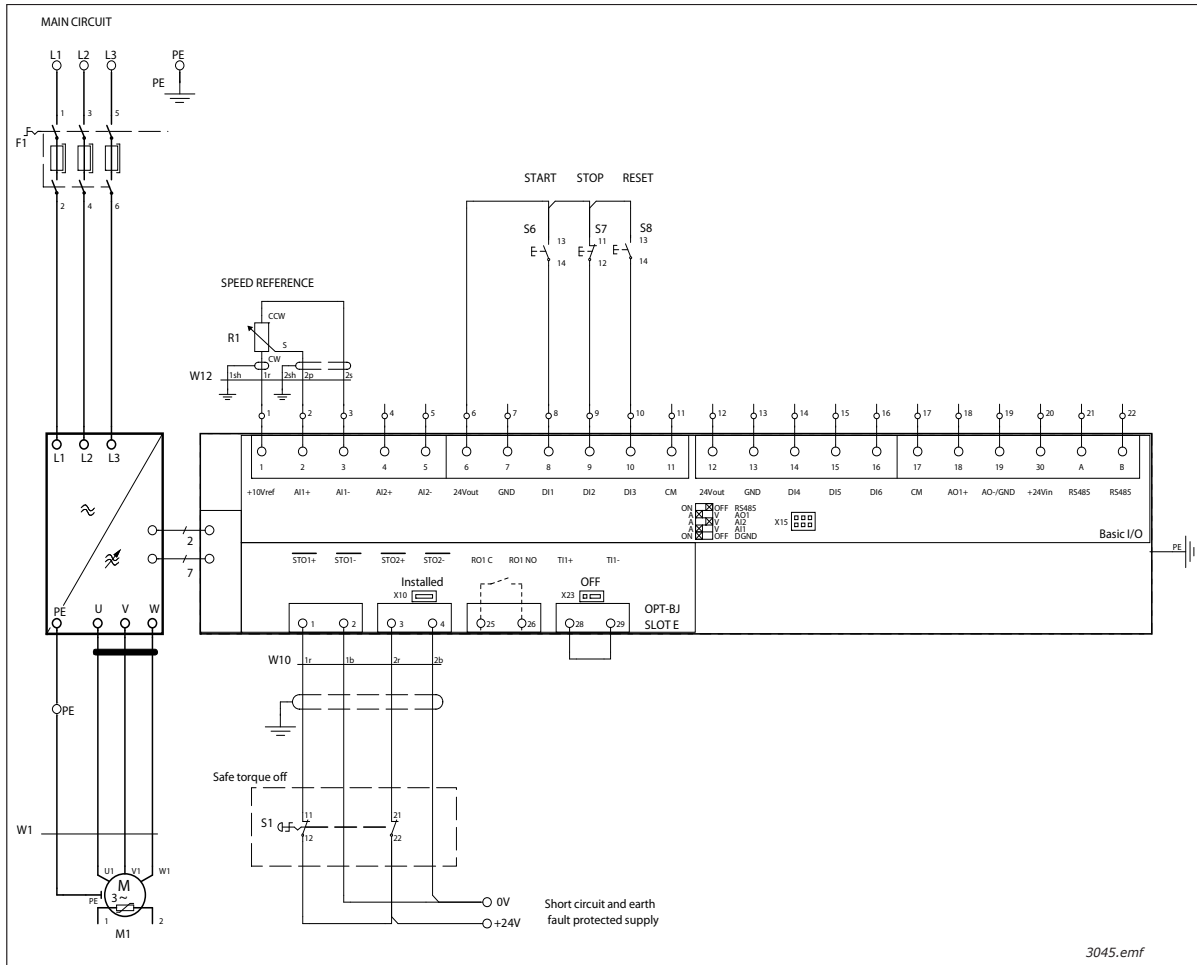

Figure above presents a connection example of OPTBJ board for STO safety function with reset. The switch S1 is connected with 4 wires to the OPTBJ board as shown above. The digital input 3 (DIN3), for example, is wired for the fault reset function. The reset function (not part of any safety function) can be programmed to any of the available digital inputs.

The power supply to S1 may come from control board (connector pins 6 & 7 in Figure above) or it may also be external, if earth fault and short circuit protected.

When the switch S1 is activated (contacts open), the drive will go to STO state and motor (if running) will stop by coasting. The drive will indicate: "30 SafeTorqueOff".

To start the motor operation again, following sequence is performed.

- Release switch S1 (contacts closed). The hardware is now enabled but the drive continues to display the fault "30 SafeTorqueOff".
- Acknowledge the releasing of switch by edge sensitive reset function. The drive returns to the ready state.
- Giving a valid start command will start running the motor.

NOTE! The Vacon 100 default application software uses edge-sensitive start as default start command, for preventing unexpected startup from STO state.

NOTE! For EN 60204-1 emergency stop according to stop category 0, use emergency stop button.

Example 3: OPTBJ board with SS1 and safety reset or EN 60204-1 stop category 1.

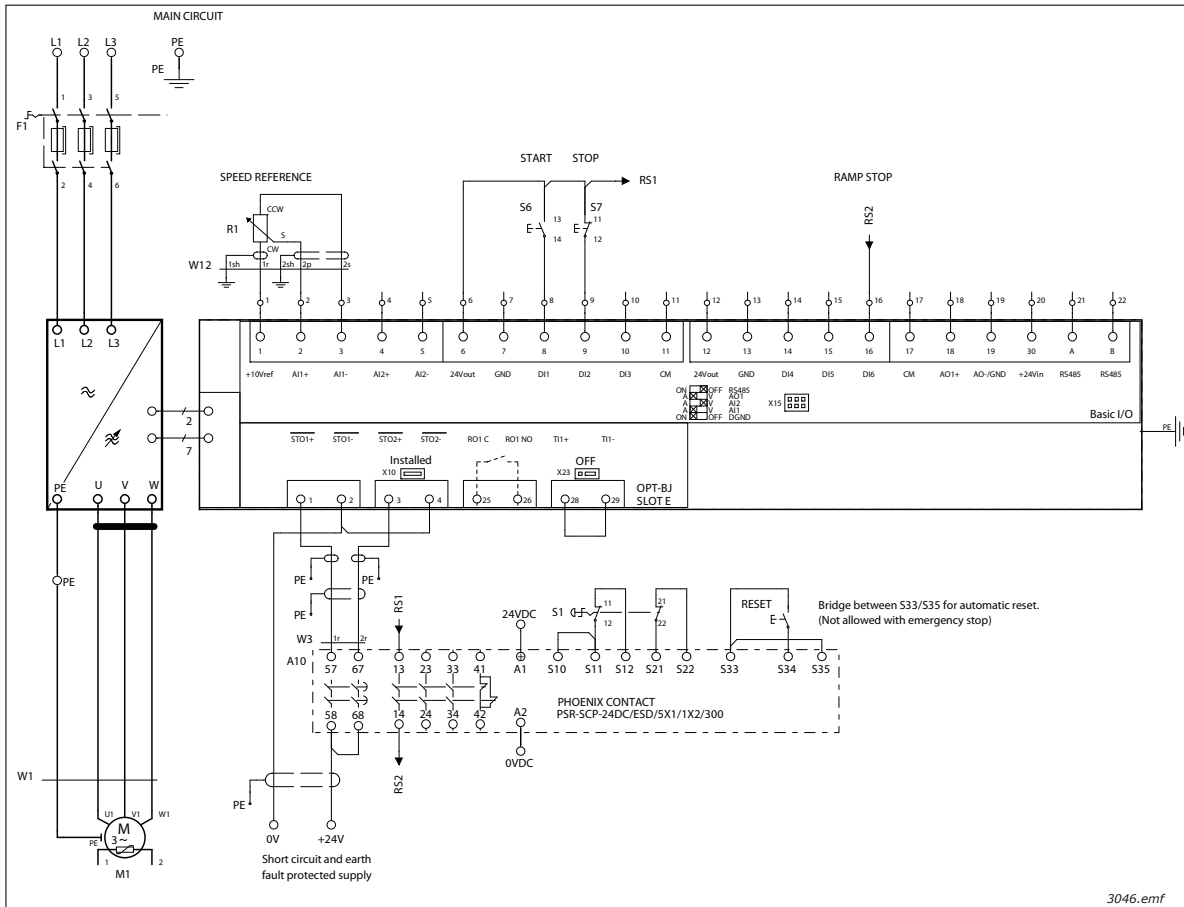

Figure above presents a connection example of OPTBJ board for SS1 safety function with external safety relay module and with safety reset.

External safety relay module is connected to the switch S1. The used power supply to switch S1 is 230 VAC as an example. The safety relay module is connected to OPTBJ board with 4 wires as shown in Figure above.

When the switch S1 is activated (contacts open), the drive will go to STO state and motor (if running) will stop by coasting. The drive will indicate: "30 SafeTorqueOff".

To start the motor operation again, following sequence is performed.

- Release switch S1 (contacts closed). The hardware is now enabled but the drive continues to display the fault "30 SafeTorqueOff".
- Acknowledge the releasing of switch by edge sensitive reset function. The drive returns to the ready state.
- Giving a valid start command will start running the motor

More information on the safety relay module may be found in the safety relay documentation.

NOTE! The Vacon 100 default application software uses edge-sensitive start as default start command, for preventing unexpected startup from STO state.

NOTE! For EN 60204-1 emergency stop according to stop category1, use emergency stop button.

5. COMMISSIONING

NOTE! The use of STO, SS1 or other safety functions does not itself ensure safety. Always make sure that the safety of the entire system is confirmed.

NOTE! The user is responsible for excluding faults in the external wiring.

5.1 GENERAL WIRING INSTRUCTIONS

- The wiring should be done according to the general wiring instructions for the specific product where OPTBJ is installed.
- Shielded cable is required for connecting the OPTBJ board.
- EN 60204-1 part 13.5: The voltage drop from supply point to load shall not exceed 5%.
- In practice, due to electromagnetic disturbances, the cable length should be limited to 25 m max. In a noisy environment, the length of the cable could still be less than 25 m, in order to avoid unwanted tripping.

Cable recommendation:

Type	E.g: 2x2x0.75mm ² low voltage, single shielded, twisted pair cable.
Maximum length	25 m between STO inputs and the operating contact

5.2 CHECKLIST FOR COMMISSIONING THE OPTBJ BOARD

Nr	Step	Yes	No
1	Has a risk assessment of the system been carried out to ensure that using the OPTBJ board Safe Torque Off (STO) or Safe Stop 1 (SS1) safety function is safe and according to local regulations ?		
2	Does the assessment include an examination of whether using external devices such as a mechanical brake is required ?		
3	Has the switch S1 been chosen according to the required safety performance target (SIL or PL) set during the risk evaluation?		
4	Is the switch S1 required to be lockable or otherwise secured in the OFF position?		
5	Is it ensured that color coding and marking of the switch S1 is in accordance with the intended use?		
6	Is the external power of the switch S1 supply earth fault and short circuit protected (EN 60204-1)?		
7	The shaft of a permanent magnet motor might in an IGBT fault situation rotate up to 180 degrees / pole of the motor. Has it been ensured that the system designed in such a way that the this can be accepted?		
8	Has the STO jumper configuration been done according to the instructions in this manual?		
9	Have process requirements (including deceleration time) been considered for correct execution of Safe Stop 1 (SS1) safety function and are the corresponding settings done?		
10	Is there a risk of conductive contamination (e.g. conductive dust) in the environment?		
11	If pollution degree 2 cannot be guaranteed, IP54 protection class shall be used.		
12	Have the User's Manual instructions for the specific product been followed ?		
13	Does the system need a safety certified prevention of unexpected start-up? The safety function has to be provided by an external safety relay.		
14	Has the system been designed in such a way that activating (enabling) the drive through STO inputs will not lead to an unexpected start of the drive?		
15	Have only approved units and parts been used?		
16	Is the Vacon 100 control board 70CVB01582 (See the sticker on the Vacon 100 control board, or "Drive Info" in Vacon Live)		
17	Is the Vacon 100 system software version FW0072V002, or newer? (Check the system software version on the keypad or in Vacon Live)		
18	Has a routine been set up to ensure that the functionality of the safety functions is being checked at regular intervals?		
19	Has this manual been read, understood and followed carefully?		
20	Have the STO and SS1 safety functions been tested properly according to Chapter 5.3?		

5.3 TESTING THE SAFE TORQUE OFF (STO) OR SAFE STOP 1 (SS1) SAFETY FUNCTIONS

NOTE! Before testing the STO or SS1 safety functions, make sure that the checklist (Chapter 5.2) is inspected and completed.

NOTE! After connecting the board ALWAYS make sure that the STO or SS1 safety functions are working properly by testing them before operating the system.

NOTE! Concerning the SS1 safety function, make sure by testing that the drive's stop by ramp function is working in accordance with the process requirements.

NOTE! If the STO safety function is used in a low-demand operating mode, it shall be tested periodically at least once a year.

When the STO safety function is activated, a code: Fault 30 "SafeTorqueOff " appears on the control keypad display. This indicates that the STO safety function is active. After STO has been deactivated, the fault remains active until the fault is acknowledged.

6. MAINTENANCE

CAUTION! If any service or repair is to be conducted on the drive installed with OPTBJ board please follow the check list given in Chapter 5.2.

CAUTION! During maintenance breaks, or in case of service/repair, the OPTBJ board might have to be removed from its slot. After reconnecting the board, ALWAYS make sure that the STO or SS1 safety functions are active and fully functional by testing them. See Ch. 5.3.

6.1 FAULTS RELATED TO THE SAFE TORQUE OFF (STO) OR SAFE STOP 1 (SS1) SAFETY FUNCTIONS

The table below shows the normal fault, generated when STO safety function is active:

Fault code	Fault	ID	Explanation	Correcting measures
30	SafeTorqueOff	530	STO activated through the OPTBJ option board	STO function activated. Drive is in safe state

The table below shows faults that may be generated from the software part that monitors the hardware related to the STO safety function. If some of the faults listed below occur, the fault may NOT be reset:

Fault code	Fault	ID	Explanation	Correcting measures
30	Safety configuration	500	STO jumper is installed on the control board.	<ul style="list-style-type: none"> Remove the STO jumper from the control board. See ch. 3.1 and 3.1.1
30	Safety configuration	501	More than one OPTBJ option board detected in the drive.	<ul style="list-style-type: none"> Only one OPTBJ board is supported by the drive. Remove other OPTBJ boards from the drive, except from slot E.
30	Safety configuration	502	OPTBJ option board installed to a wrong slot.	<ul style="list-style-type: none"> OPTBJ option board can only be installed to slot E. Install the board to slot E.
30	Safety configuration	503	STO jumper missing from the control board.	<ul style="list-style-type: none"> Install the STO jumper to the control board, when the OPTBJ board has been removed from the drive. See ch. 3.1 and 3.1.1
30	Safety configuration	504	Problem detected in STO jumper installation on the control board.	<ul style="list-style-type: none"> Check the installation of the STO jumper on the control board. See ch. 3.1 and 3.1.1.
30	Safety configuration	505	Problem detected in STO jumper installation on the OPTBJ board.	<ul style="list-style-type: none"> Check the installation of STO jumper switch on the OPTBJ board. See ch. 3.1 and 3.1.1
30	Safety configuration	506	Communication has been failed between the control board and OPTBJ option board.	<ul style="list-style-type: none"> Check the installation of the OPTBJ board. Restart the drive. Change the OPTBJ board if necessary. Should the fault re-occur, contact the distributor near to you.
30	Safety configuration	507	The hardware does not support the OPTBJ board.	<ul style="list-style-type: none"> Restart the drive. Should the fault re-occur, contact the distributor near to you.

Fault code	Fault	ID	Explanation	Correcting measures
30	Safety diagnostics	520	There is a diagnostic failure in the STO safety function.	<ul style="list-style-type: none"> Restart the drive. If the restart does not help, change the OPTBJ board. Should the fault re-occur, contact the distributor near to you. Deliver the fault report to the distributor, see fault details for more information.
30	Safety diagnostics	521	Atex-thermistor diagnostic fault.	<ul style="list-style-type: none"> Restart the drive. If the restart does not help, change the OPTBJ board. Should the fault re-occur, contact the distributor near to you
30	Safety diagnostics	522	Atex-thermistor short-circuit.	<ul style="list-style-type: none"> Check the connection of the Atex-thermistor Check the thermistor Restart the drive. If the restart does not help, change the OPTBJ board. Should the fault re-occur, contact the distributor near to you

7. THERMISTOR FUNCTION (ATEX)

The thermistor overtemperature supervision is designed in accordance with ATEX directive 94/9/EC. It is approved by VTT Finland for group II (certificate nr. VTT 06 ATEX 048X), category (2) in the 'G' area (area in which potentially explosive gas, vapor, mist or air mixtures are present) and D area (area with combustible dust). The "X" in the certificate number refers to special conditions for safe use. See the conditions in the last note in this page.



0537



II (2) GD

It can be used as an overtemperature tripping device for motors in explosive area (EX motors).

Note: The OPTBJ board also contains the Safe Torque Off (STO) safety function. When STO is not intended to be used, inputs STO1+(OPTBJ:1), STO2+(OPTBJ:3) are to be connected to +24V (e.g. pin 6 in Vacon 100 control board). STO1-(OPTBJ:2), STO2- (OPTBJ:4) are to be connected to GND (for e.g. pin 7 or 13 on Vacon 100 control board).

NOTE! Safety devices like the OPTBJ board must be correctly incorporated into the entire system. The functionality of the OPTBJ board is not necessarily suitable for all systems. The entire system must be designed in compliance with all relevant standards within the field of industry.

CAUTION! The information in this manual provides guidance on the use of thermistor function for protecting overheating of motors in explosive atmosphere. However, the end product/system designer is responsible for ensuring that the system is safe and in compliance with relevant regulations.

CAUTION! During maintenance breaks, or in case of service/repair the OPTBJ board might have to be removed from its slot. After reconnecting the board ALWAYS make sure that the thermistor function is working correctly by testing it.

CAUTION! The thermistor function on OPTBJ board with Vacon 100 control is used to protect the overheating of motors in explosive atmosphere. The drive itself including OPTBJ board can not be installed in explosive atmosphere.

NOTE! Special conditions required for safe use (X in the certificate number):
This function can be used with Exe-, Exd-, and ExnA- type of motors. In case of Exe-, and ExnA- motors, the end user has to confirm that the installation of the measurement circuit is done according to area classification. E.g. in Exe- and ExnA- motors PTC sensors shall be certified together with the motor according to the requirements of the type of protection. The allowed ambient temperature range for the drive is -10°C...+50°C.

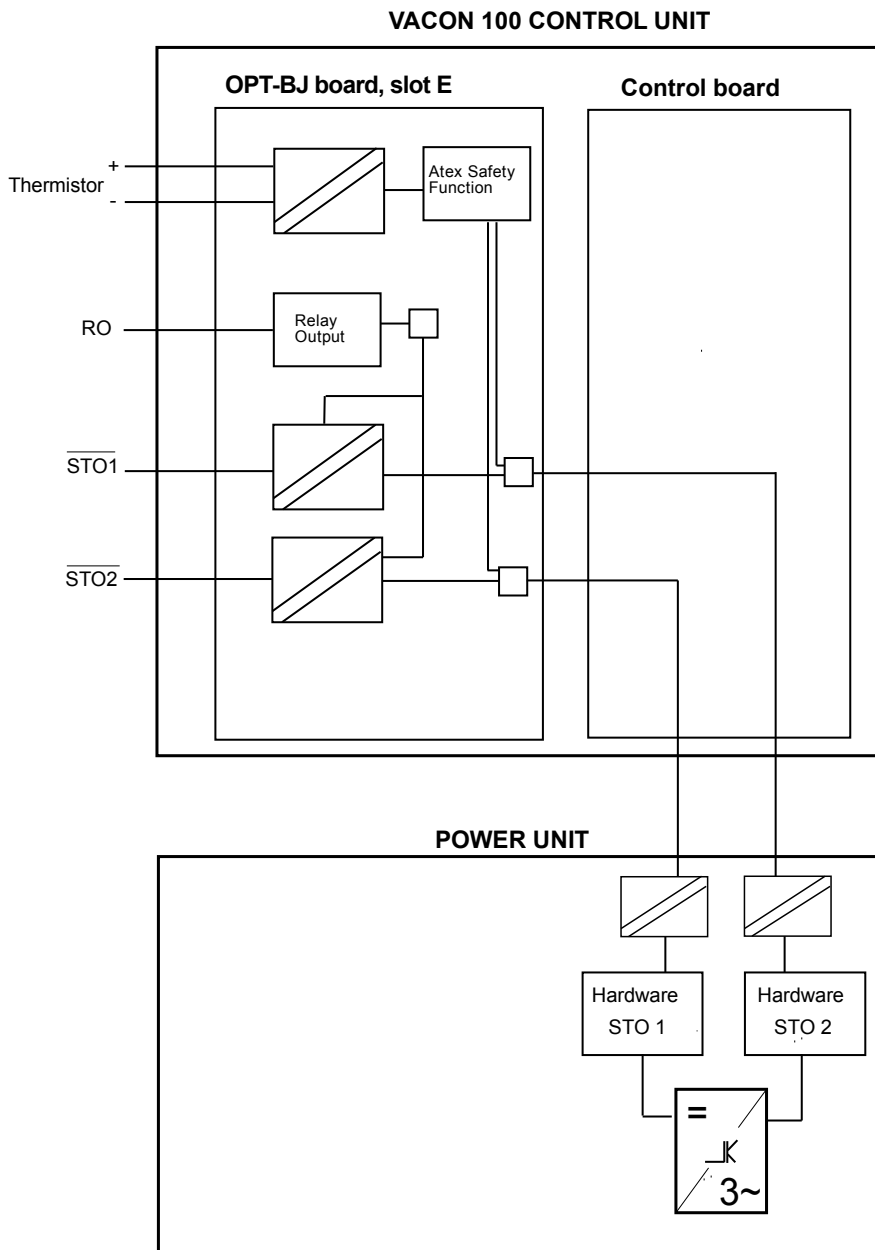

Figure 8. Thermistor function principle in Vacon 100 frequency converter with the OPTBJ board

7.1 TECHNICAL DATA

7.1.1 FUNCTIONAL DESCRIPTION

The thermistor supervision circuit of the OPTBJ board is designed to provide a reliable way of disabling the drive modulation in case there is an overtemperature at the motor thermistor(s).

By disabling the drive modulation the feeding of the energy to the motor is prevented and a further heating up of the motor due to this is avoided.

The thermistor supervision circuit meets the requirements in the ATEX directive by directly activating the "STO" safety function of the Vacon 100 (See Figure 8) and thus provides a reliable, software and parameter independent way of preventing the energy supply to the motor.

7.1.2 HARDWARE AND CONNECTIONS

See Chapter 4.3.2

The thermistor (PTC) is connected between the terminals 28(T11+) and 29(T11-) of the OPTBJ board. The optocoupler isolates the thermistor inputs from the control board potential

* If 230VAC is used as control voltage from the output relays, the control circuitry must be powered with a separate isolation transformer to limit short circuit current and overvoltage spikes. This is to prevent the welding on the relay contacts.

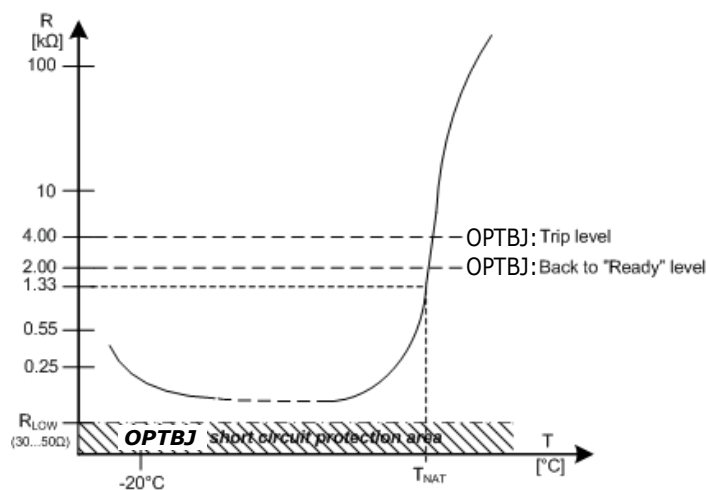

Figure 9. Typical characteristics of a motor-protection sensor as specified in DIN 44081/DIN 440

7.1.3 ATEX FUNCTION

When drive is connected to the main power and if the motor temperature is below overtemperature limits (see Figure 9), the drive goes to ready state. The motor may start after a valid start command.

If the motor temperature is above the overtemperature limits (see Figure 9), fault 29 (Atex thermistor) is activated.

When the resistance of the thermistor(s) mounted in the motor goes above 4 kΩ due to motor overheating, the drive modulation is disabled within 20ms.

According to Figure 9, when the temperature falls below 2 kΩ, the thermistor function allows fault reset and entering to ready state.

7.1.4 SHORT CIRCUIT MONITORING

The thermistor inputs T11+ and T11- are monitored for short circuit. If a short circuit is detected, the drive modulation is disabled within 20ms, Fault 30, Safety diagnostic (subcode 522) is generated. When the short circuit has been removed, the drive can be reset only after a power recycle.

The short circuit monitoring can be enabled or disabled using the jumper X23 in ON or OFF position respectively. The jumper is set in ON position by factory default.

7.2 COMMISSIONING

NOTE! Installation, testing and service work on the OPTBJ board can be performed only by qualified persons.

NOTE! It is not allowed to perform any repair work on the OPTBJ board. Please return faulty boards to Vacon for analysis.

NOTE! It is recommended to test the ATEX functionality using thermistor input on OPTBJ board periodically (typically once a year). For testing, activate the thermistor functionality (e.g. remove ATEX-thermistor plug from the OPTBJ board). The drive shall enter to fault state and indicate fault 29 (ATEX-thermistor fault, subcode 280).

7.2.1 GENERAL WIRING INSTRUCTIONS

The thermistor connection must be done using a separate control cable. It is not allowed to use wires belonging to the motor supply cables or any other main circuit cables. A shielded control cable must be used. See also Chapter 2.

	Maximum cable length without short circuit monitoring X23 : OFF	Maximum cable length without short circuit monitoring X23 : ON
>= 1.5 sq mm	1500 meters	250 meters

7.2.2 FAULT DIAGNOSIS OF THERMISTOR FUNCTION

The table below shows the normal fault / warning, generated when thermistor input is active

Fault code	Fault	ID	Explanation	Correcting measures
29	Atex-thermistor	280	Atex-thermistor has detected overtemperature.	

See the fault table in chapter 6.1.

VACON

DRIVEN BY DRIVES

Find your nearest Vacon office
on the Internet at:

www.vacon.com



Manual authoring:
documentation@vacon.com

Vacon Plc.
Runsorintie 7
65380 Vaasa
Finland

Subject to change without prior notice
© 2012 Vacon Plc.

Document ID:



Order code:



Rev. A