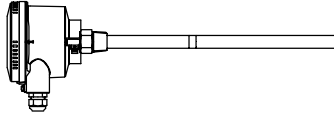
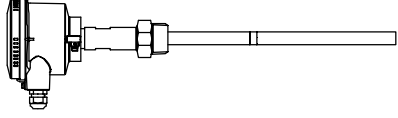

Table of content

	Page
Overview	2
<hr style="border-top: 1px dashed black;"/>	
RF 8100	4
	
<hr style="border-top: 1px dashed black;"/>	
RF 8200	6
	
<hr style="border-top: 1px dashed black;"/>	
Options	8
Accessories	9
Dimensions	10
Detailed Ex-markings	13
Electrical installation	14
Spare parts	15

Subject to change.

All dimensions in mm (inches).

All prices in Euro (€) or USD (\$),
 excluding VAT.

All EURO prices are EXW Betzigau,
 all USD prices are EXW Memphis,
 excluding packaging costs.

Valid: From 01.01.2019 until 31.03.2020, unless otherwise
 agreed.

By publishing this selection list all other lists become invalid.

We assume no liability for typing errors.

Different variations to those specified are possible.
 Please contact our technical consultants.

Overview

- Level limit detection in liquids, slurries, foam, interfaces and solids
- Compact unit
- Wide range of applications
- No maintenance
- Full-, demand-, empty detector
- Extended rod version or rope version
- High pressure and high temperature
- High chemical resistance on probes
- RF technology with active shield
- Sensitivity: dielectric constant ≥ 1.5
- Simple modification of probe possible on site

Standard electronics with:

- Universal power supply
- Solid-state switch and Relay output

Digital electronics with:

- Communication via Profibus PA
- Integrated Local User Interface
- Self diagnostics
- Multiple approvals available
- 2011/65/EU RoHS conform

Approvals	CE		
	ATEX	Zone 0	Intrinsically Safe
		Zone 0/1	Flameproof
		Zone 20/21	Dust Ignition Proof
	FM / CSA	General purp.	
		Cl. I Div. 1	Intrinsically Safe
		Cl. I Div. 1	Explosionproof
		Cl. II, III Div. 1	Dust Ignition Proof
	TR-CU	Ordinary Locations, Intrinsically Safe, Flameproof, Dust Ignition Proof	
	INMETRO	Flameproof, Dust Ignition Proof	
Lloyds	Categories ENV1, ENV2, ENV3 and ENV5		
WHG	Overfill protection		

		Electronic module Standard	Electronic module Digital
Electronics	Supply voltage	12 .. 250 V AC/ DC (0 .. 60 Hz)	12 .. 30 V DC (24 V for IS version)
	Signal output	Relais SPDT Solid-state switch (30 V DC/ AC peak, 82 mA)	Profibus PA Solid-state switch (30 V DC/ AC peak, 82 mA)
	Signal output delay	Rise time or Fall time 1 .. 60 sec.	Rise time 0 .. 100 sec. Fall time 0 .. 100 sec.
	Failsafe	High or Low	High or Low
	User interface	Potentiometer, switches, 3 LED indicator	LCD local user interface or Profibus PA
	Diagnostics	-	Over and Under Range Electronics temperature Function check Maintenance alarm Internal electronic self check

Housing	Material	Aluminium, powder-coated
	Ingress protection	Type 4/ NEMA 4/ IP68
	Temperature extended shaft	Option for RF 8100, standard for RF 8200: Material 1.4404 (SS316L)
	Ambient temperature	-40 .. 85°C (-40 .. 185°F) With ATEX approval: -40 .. 80°C (-40 .. 176°F) with Flameproof or Dust Ignition Proof -40 .. 60°C (-40 .. 140°F) with Intrinsically safe

Overview

RF 8100 Standard version				
Mechanics and Process	Length of extension "L"	Rod Rope	350 .. 1,000 mm (13.78 .. 39.37") 550 .. 25,000 mm (19.7 .. 984.3")	
	Active shield length	Threaded Flanged	125 .. 400 mm (4.92 .. 15.75") 105 .. 380 mm (4.13 .. 14.96")	
	Diameter of rod/ rope	Rod Rope	ø19 mm (ø0.75") ø6 mm (ø0.3")	
	Materials	Process connection		1.4404 (SS316L)
		Active shield area		PFA coated
		Rod		1.4404 (SS316L)
		Rope		1.4404 (SS316L)
		Rope insulation		PFA (optional)
Process temperature	Probe isolators		PEEK	
	Wetted seals		FKM or FFKM	
Process pressure	Without temperature extended shaft: -40 .. 85°C (-40 .. 185°F) With temperature extended shaft: -40 .. 200°C (-40 .. 392°F)			
Tensile load	-1 .. 35 bar g (-14.6 .. 511 psi g) nominal Observe Pressure versus Temperature Curves			
			max. 18.5 kN (rope version)	

Rod version threaded



Rope version flanged



RF 8200 High temperature version (400°C)				
Mechanics and Process	Length of extension "L"	Rod	350 .. 1,000 mm (13.78 .. 39.37")	
	Active shield length	Threaded Flanged	125 .. 400 mm (4.92 .. 15.75") 105 .. 380 mm (4.13 .. 14.96")	
	Diameter	Rod	ø19 mm (ø0.75")	
	Materials	Process connection		1.4404 (SS316L)
		Rod		1.4404 (SS316L)
		Probe isolators		Ceramic
Process temperature	Wetted seals		Graphite	
	-40 .. 400°C (-40 .. 752°F)			
Process pressure	-1 .. 35 bar g (-14.6 .. 511 psi g) nominal Observe Pressure versus Temperature Curves			

Rod version Threaded



Rod version Flanged



RF 8100 Standard version

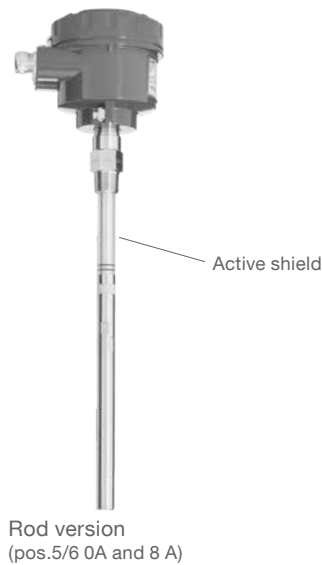

Cable entries (by default)

Depending on model selected, the following cable entries are supported (options see pos.33 on page 8):

Version:	Cable entries:
Flameproof (pos.2 T,D)	M20 x 1.5 (1x open conduit + 1x Ex-d blind plug)
FM/ CSA (pos.2 M,U,P,N)	NPT 1/2" tapered ANSI B1.20.1 (1x open conduit + 1x Ex-d blind plug)
All other versions	M20 x 1.5 (1x screwed cable gland + 1x blind plug)

Dimensions see page 10 - 13

Basic type

RF 8100

pos.2 Certificate (detailed Ex-markings: see page 13)

	Gas	Dust	Protection method
0	CE ⁽⁴⁾	-	-
Q	CE/ FM/ CSA ^(1,4)	-	-
T	ATEX ^(2,4)	Zone 0/1	Zone 20/21 Flameproof, Dust Ignition Proof
Y	ATEX ^(2,5)	Zone 0	Zone 20/21 Intrinsically Safe
W	ATEX ^(2,4)	-	Zone 20/21 Dust Ignition Proof
M	FM/ CSA ⁽⁴⁾	-	- General purpose
U	FM/ CSA ⁽⁴⁾	Cl. I Div. 1	Cl. II, III Div. 1 Explosion Proof, Dust Ignition Proof
P	FM/ CSA ⁽⁵⁾	Cl. I Div. 1	Cl. II, III Div. 1 Intrinsically Safe
N	FM/ CSA ⁽⁴⁾	-	Cl. II, III Div. 1 Dust Ignition Proof
D	INMETRO	Zone 1	Zone 21 Flameproof, Dust Ignition Proof

pos.3 Temperature extended shaft

- 1 without
- 2 with

pos.4 Electronic module

- E Standard: Relay SPDT/ Solid State 12 ... 250 V AC/ DC⁽⁶⁾
- F Digital: Profibus PA/ Solid State 12 ... 30 V DC (24 V intrinsic safe) LCD display⁽⁷⁾

pos.5+6 Process connection

- 0A Thread 3/4" NPT taper, ANSI/ASME B1.20.1⁽⁸⁾
- 0B Thread 1" NPT taper, ANSI/ASME B1.20.1⁽⁸⁾
- 0C Thread 1 1/4" NPT taper, ANSI/ASME B1.20.1
- 0D Thread 1 1/2" NPT taper, ANSI/ASME B1.20.1
- 1A Thread R 3/4" BSPT, EN 10226/PT (JIS-T), JIS B 0203⁽⁸⁾
- 1B Thread R 1" BSPT, EN 10226/PT (JIS-T), JIS B 0203⁽⁸⁾
- 1D Thread R 1 1/2" BSPT, EN 10226/PT (JIS-T), JIS B 0203
- 3A Thread G 3/4" BSPP, EN ISO 228-1/PF (JIS-P), JIS B 0202⁽⁸⁾
- 3B Thread G 1" BSPP, EN ISO 228-1/PF (JIS-P), JIS B 0202⁽⁸⁾
- 3D Thread G 1 1/2" BSPP, EN ISO 228-1/PF (JIS-P), JIS B 0202

RF 8100 Standard version

5A	Flange 1"	150 lbs	ASME B16.5, raised face ⁽⁶⁾	•	
5B	Flange 1"	300 lbs	ASME B16.5, raised face ⁽⁶⁾	•	
5C	Flange 1"	600 lbs	ASME B16.5, raised face ⁽⁶⁾	•	
5D	Flange 1½"	150 lbs	ASME B16.5, raised face	•	
5E	Flange 1½"	300 lbs	ASME B16.5, raised face	•	
5F	Flange 1½"	600 lbs	ASME B16.5, raised face	•	
5G	Flange 2"	150 lbs	ASME B16.5, raised face	•	
5H	Flange 2"	300 lbs	ASME B16.5, raised face	•	
5J	Flange 2"	600 lbs	ASME B16.5, raised face	•	
5K	Flange 3"	150 lbs	ASME B16.5, raised face	•	
5L	Flange 3"	300 lbs	ASME B16.5, raised face	•	
5M	Flange 3"	600 lbs	ASME B16.5, raised face	•	
5N	Flange 4"	150 lbs	ASME B16.5, raised face	•	
5P	Flange 4"	300 lbs	ASME B16.5, raised face	•	
5Q	Flange 4"	600 lbs	ASME B16.5, raised face	•	
6A	Flange DN25, PN16		EN 1092-1 type A flat faced ⁽⁶⁾	•	
6B	Flange DN25, PN40		EN 1092-1 type A flat faced ⁽⁶⁾	•	
6C	Flange DN40, PN16		EN 1092-1 type A flat faced	•	
6D	Flange DN40, PN40		EN 1092-1 type A flat faced	•	
6E	Flange DN50, PN16		EN 1092-1 type A flat faced	•	
6F	Flange DN50, PN40		EN 1092-1 type A flat faced	•	
6G	Flange DN80, PN16		EN 1092-1 type A flat faced	•	
6H	Flange DN80, PN40		EN 1092-1 type A flat faced	•	
6J	Flange DN100, PN16		EN 1092-1 type A flat faced	•	
6K	Flange DN100, PN40		EN 1092-1 type A flat faced	•	
pos.8 Length of extension "L"						
A	Rod, 350 mm (13.78")			•	
B	Rod, 500 mm (19.69")			•	
C	Rod, 750 mm (29.53")			•	
D	Rod, 1,000 mm (39.37")			•	
Y	Rod, "L"= customer specified					
	Price per 100 mm (3.94") of part thereof (starting from 0 mm)			•	
	min. 250 mm (9.8"), max. 999 mm (39.3")					
P	Rope, 3,000 mm (118.11"), length can be shortened by customer			•	•
Q	Rope, 6,000 mm (236.22"), length can be shortened by customer			•	•
Z	Rope, "L"= customer specified					
	Base price			•	•
	Price per 100 mm (3.94") of part thereof (starting from 0 mm)			•	•
	min. 550 mm (19.7"), max. 25,000 mm (984.3")					
pos.9 Active Shield length						
A	125 mm threaded/ 105 mm flanged			•	
B	250 mm threaded/ 230 mm flanged ⁽⁹⁾			•	
C	400 mm threaded/ 380 mm flanged ⁽¹⁰⁾			•	
pos.10 Material of process connection and extension "L"						
2	Stainless steel 1.4404 (316L), isolation parts PEEK, active shield coated with PFA			•	
3	Stainless steel 1.4404 (316L), isolation parts PEEK, active shield and rope coated with PFA ⁽¹¹⁾			•	

Further options: see page 8

- (1) Included is: TR-CU (Ordinary Locations)
- (2) Included is: TR-CU
- (4) Included is: Lloyds
- (5) Intrinsically safe barrier required
- (6) Not available in combination with Intrinsically safe pos.2 Y,P
- (7) Not available with certificate Lloyds
- (8) Not available with rope version (pos.8 P,Q,Z)
- (9) Availabe with Length of extension "L": Rod min. 500 mm (19.69"), Rope min. 1,000 mm (39.37")
- (10) Availabe with Length of extension "L": Rod min. 750 mm (29.53"), Rope min. 1,000 mm (39.37")
- (11) Availabe only with rope version (pos.8 P,Q,Z)

RF 8100	A					1			
Position	1	2	3	4	5+6	7	8	9	10

L = **mm** ← **Order code**

All positions are available with special design (use code "Z").

RF 8200 High temperature version (400°)

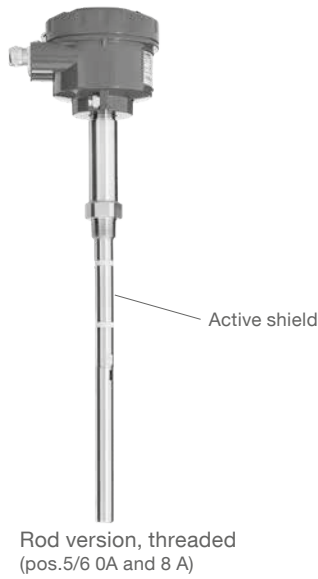

Cable entries (by default)

Depending on model selected, the following cable entries are supported (options see pos.33 on page 8):

Version:	Cable entries:
Flameproof (pos.2 T,D)	M20 x 1.5 (1x open conduit + 1x Ex-d blind plug)
FM/ CSA (pos.2 M,U,P,N)	NPT ½" tapered ANSI B1.20.1 (1x open conduit + 1x Ex-d blind plug)
All other versions	M20 x 1.5 (1x screwed cable gland + 1x blind plug)

Dimensions see page 10

Basic type

RF 8200

pos.2

Certificate (detailed Ex-markings: see page 13)

	Gas	Dust	Protection method
0	CE ⁽⁴⁾	-	-
Q	CE/ FM/ CSA ^(1, 4)	-	-
T	ATEX ^(2, 4)	Zone 0/1	Zone 20/21
Y	ATEX ^(2, 5)	Zone 0	Zone 20/21
W	ATEX ^(2, 4)	-	Zone 20/21
M	FM/ CSA ⁽⁴⁾	-	-
U	FM/ CSA ⁽⁴⁾	Cl. I Div. 1	Cl. II, III Div. 1
P	FM/ CSA ⁽⁵⁾	Cl. I Div. 1	Cl. II, III Div. 1
N	FM/ CSA ⁽⁴⁾	-	Cl. II, III Div. 1
D	INMETRO	Zone 1	Zone 21

pos.4

Electronic module

E	Standard: Relay SPDT/ Solid State	12 ... 250 V AC/ DC ⁽⁶⁾	
F	Digital: Profibus PA/ Solid State	12 ... 30 V DC (24 V intrinsic safe)	LCD display ⁽⁷⁾

pos.5+6

Process connection

0A	Thread ¾" NPT	taper, ANSI/ASME B1.20.1	
0B	Thread 1" NPT	taper, ANSI/ASME B1.20.1	
0C	Thread 1¼" NPT	taper, ANSI/ASME B1.20.1	
0D	Thread 1½" NPT	taper, ANSI/ASME B1.20.1	
1A	Thread R ¾"	BSPT, EN 10226/PT (JIS-T), JIS B 0203	
1B	Thread R 1"	BSPT, EN 10226/PT (JIS-T), JIS B 0203	
1D	Thread R 1½"	BSPT, EN 10226/PT (JIS-T), JIS B 0203	
3A	Thread G ¾"	BSPP, EN ISO 228-1/PF (JIS-P), JIS B 0202	
3B	Thread G 1"	BSPP, EN ISO 228-1/PF (JIS-P), JIS B 0202	
3D	Thread G 1½"	BSPP, EN ISO 228-1/PF (JIS-P), JIS B 0202	

RF 8200 High temperature version (400°)

5A	Flange 1"	150 lbs	ASME B16.5, raised face	•
5B	Flange 1"	300 lbs	ASME B16.5, raised face	•
5C	Flange 1"	600 lbs	ASME B16.5, raised face	•
5D	Flange 1½"	150 lbs	ASME B16.5, raised face	•
5E	Flange 1½"	300 lbs	ASME B16.5, raised face	•
5F	Flange 1½"	600 lbs	ASME B16.5, raised face	•
5G	Flange 2"	150 lbs	ASME B16.5, raised face	•
5H	Flange 2"	300 lbs	ASME B16.5, raised face	•
5J	Flange 2"	600 lbs	ASME B16.5, raised face	•
5K	Flange 3"	150 lbs	ASME B16.5, raised face	•
5L	Flange 3"	300 lbs	ASME B16.5, raised face	•
5M	Flange 3"	600 lbs	ASME B16.5, raised face	•
5N	Flange 4"	150 lbs	ASME B16.5, raised face	•
5P	Flange 4"	300 lbs	ASME B16.5, raised face	•
5Q	Flange 4"	600 lbs	ASME B16.5, raised face	•
6A	Flange DN25, PN16		EN 1092-1 type A flat faced	•
6B	Flange DN25, PN40		EN 1092-1 type A flat faced	•
6C	Flange DN40, PN16		EN 1092-1 type A flat faced	•
6D	Flange DN40, PN40		EN 1092-1 type A flat faced	•
6E	Flange DN50, PN16		EN 1092-1 type A flat faced	•
6F	Flange DN50, PN40		EN 1092-1 type A flat faced	•
6G	Flange DN80, PN16		EN 1092-1 type A flat faced	•
6H	Flange DN80, PN40		EN 1092-1 type A flat faced	•
6J	Flange DN100, PN16		EN 1092-1 type A flat faced	•
6K	Flange DN100, PN40		EN 1092-1 type A flat faced	•
pos.8 Length of extension "L"					
A	Rod, 350 mm (13.78")		•	
B	Rod, 500 mm (19.69")		•	
C	Rod, 750 mm (29.53")		•	
D	Rod, 1,000 mm (39.37")		•	
Y	Rod, "L"= customer specified				
	Price per 100 mm (3.94") of part thereof (starting from 0 mm)		•	
	min. 250 mm (9.8"), max. 999 mm (39.3")				
pos.9 Active Shield length					
A	125 mm threaded/ 105 mm flanged		•	
B	250 mm threaded/ 230 mm flanged ⁽⁸⁾		•	
C	400 mm threaded/ 380 mm flanged ⁽⁹⁾		•	
pos.10 Material of process connection and extension "L"					
4	Stainless steel 1.4404 (316L), isolation parts ceramic		•	

Further options: see page 8

- (1) Included is: TR-CU (Ordinary Locations).
- (2) Included is: TR-CU.
- (4) Included is: Lloyds.
- (5) Intrinsically safe barrier required.
- (6) Not available in combination with Intrinsically safe pos.2 Y,P.
- (7) Not available with certificate Lloyds.
- (8) Avaliabe with Length of extension "L" min. 500 mm (19.69").
- (9) Avaliabe with Length of extension "L" min. 750 mm (29.53").

RF 8200	B	2			1			4	
Position	1	2	3	4	5+6	7	8	9	10

L = ← **Order code**

All positions are available with special design (use code "Z").

Options

Options

pos.11 x	Guarantee extension to 5 years	•
pos.17 x	FFKM wetted seals ⁽¹⁾	•
pos.23 x	WHG approval ⁽²⁾	•
pos.25 x	Inspection certificate	•
	Type 3.1 (EN 10204)	
pos.26 x	Manufacturer's Test Certificate	•
	M to DIN 55350, Part 18 and to ISO 9000	
pos.30 x	Stainless steel tag	•
	Measuring point number/ identification (max. 27 characters)	
Cable entry		
Selection of the following options only necessary, if a deviation from default is required:		
pos.33 x	M20 x 1.5 2x screwed cable gland ⁽³⁾	•
pos.33 e	M20 x 1.5 1x screwed cable gland + 1x blind plug ⁽⁴⁾	•
pos.33 a	NPT ½" tapered ANSI B1.20.1 (1x conduit + 1x Ex-d blind plug) ⁽⁵⁾	•
Signal lamp ^(6, 9)		
pos.34 a	Bulb, mounted in cable gland M20 x 1.5, 2 W green	•
pos.34 b	Bulb, mounted in cable gland M20 x 1.5, 2 W red	•
Plug ^(7, 9)		
pos.35 x	Valve connector (incl. mating plug) 4-pole (incl. PE) max. 230 V	•
pos.35 a	M12 (without mating plug) 4-pole max. 25 V	•
pos.35 b	M12 (without mating plug) 5-pole (incl. PE) max. 60 V	•
pos.35 c	Harting Han 4A (incl. mating plug) 5-pole (incl. PE) max. 230 V	•
pos.36 x	Glass window in lid ⁽⁸⁾	•

(1) Available for RF 8100. Process temperature limited to -20°C (-4°F).

(2) Available with certificate CE (pos.2 0,Q) or ATEX Flameproof (pos.2 T). Only with electronic module Standard (pos.4 E).

(3) Available for all versions except flameproof/ explosion proof version (pos.2 T,U,D).

(4) Available for FM/ CSA version (pos.2 M,P,N) except explosion proof version (pos.2 U).

(5) Available for all versions except FM/ CSA (pos.2 M,U,P,N).

(6) Available for CE (pos.2 0) and electronic module standard (pos.4 E). Not in combination with cable entries pos.33 x.

Three bulbs (24 V, 115 V and 230 V) will be delivered. Connection of bulb wires to internal terminals according to customer specification.

(7) Available for CE (pos.2 0). Not in combination with cable entries pos.33 x,e,a. Connection of plug wires to internal terminals according to customer specification.

(8) Available for electronic module digital (pos.4 F).

(9) Not available with certificate Lloyds.

Options/ Accessories

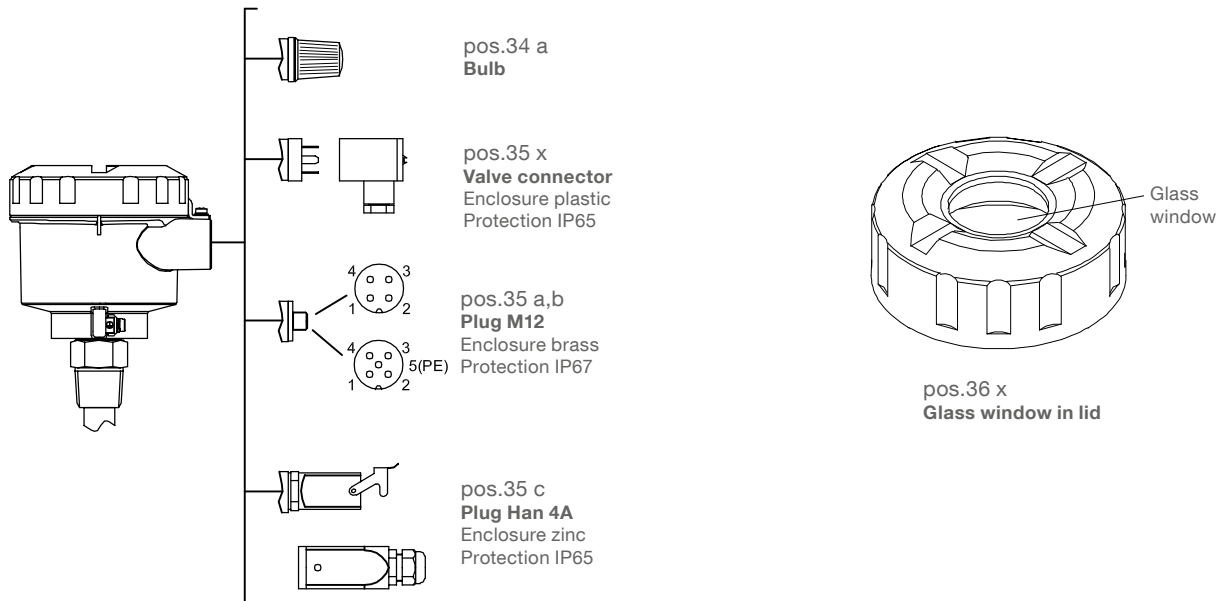

Accessories

Minimum order value for separate orders of spare parts or accessories is 75 €.

em440041 Cable gland M20 x 1.5 Ex-d •

Cable gland M20 x 1.5 Ex-d

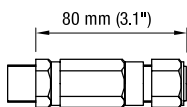

For use with version
 ATEX flameproof (pos.2 T).
 Type: Stahl T3CDS 246560

Dimensions

Enclosure

Top view

M20 x 1.5 cable gland

NPT 1/2" conduit

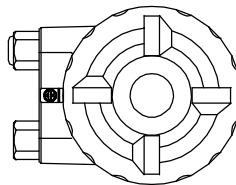
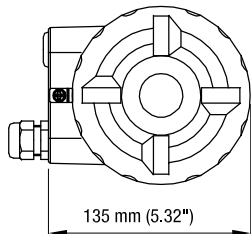

Threaded process connection

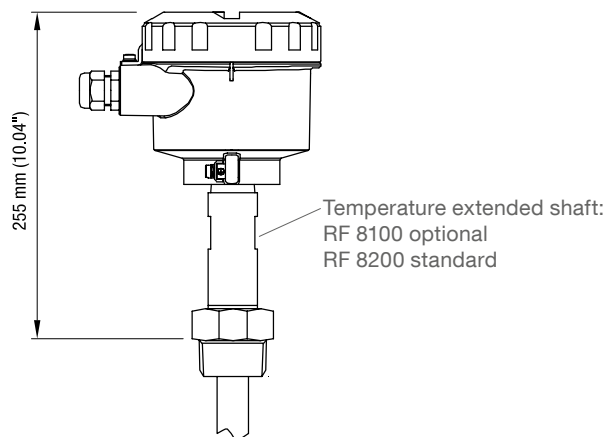
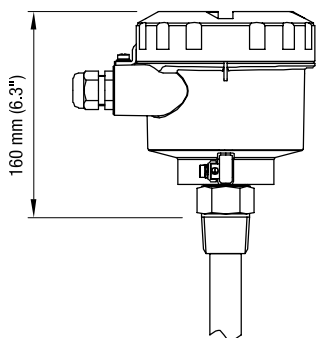

Flanged process connection

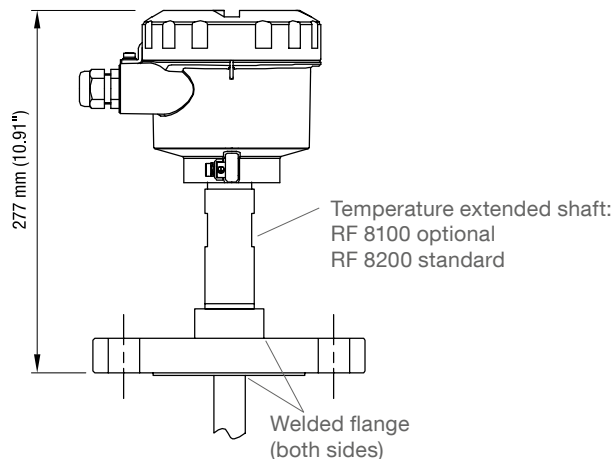
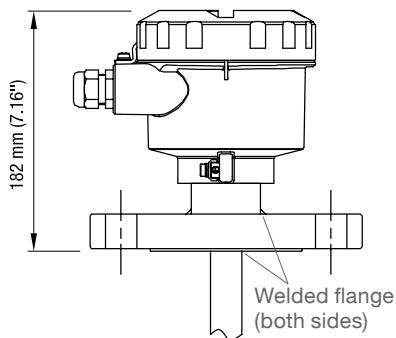

Dimensions

RF 8100 Rod version
 RF 8200 Rod version (high temperature)

Threaded process connection

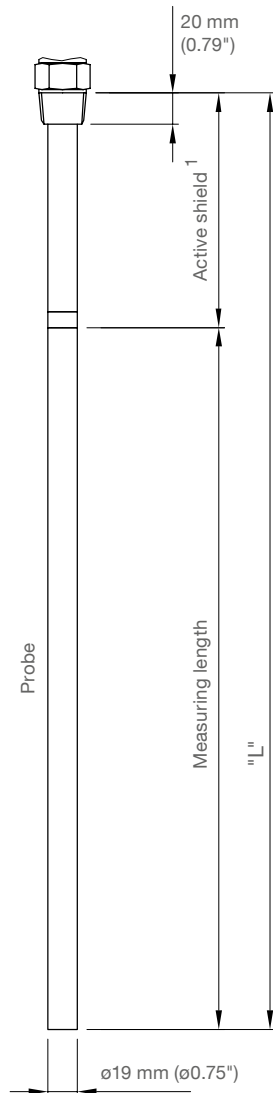

Flanged process connection

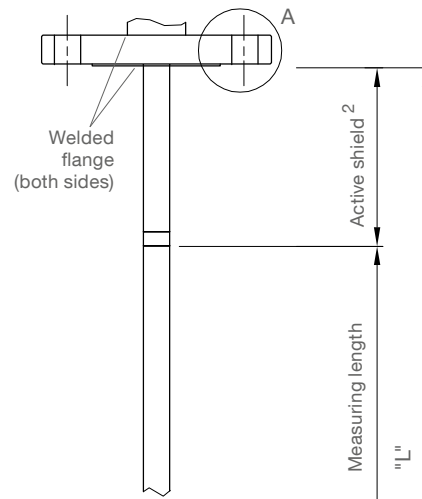

Detail "A"

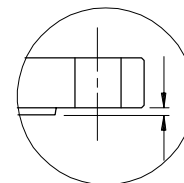

"L" does not include any raised face (see page 13)

¹ For RF 8100 coated with PFA
 Standard 125 mm (4.92")
 Optional 250 mm (9.84") or
 400 mm (15.75")

² For RF 8100 coated with PFA
 Standard 105 mm (4.13")
 Optional 230 mm (9.06") or
 380 mm (14.96")

Dimensions

RF 8100 Rope version

Threaded process connection

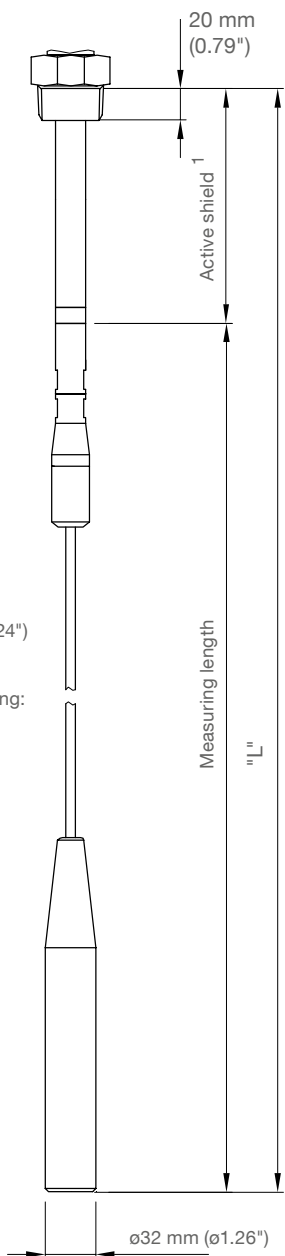

Rope: ø6 mm (ø0.24")

For RF 8100 with optional PFA coating: ø10 mm (ø0.36")

¹ Coated with PFA
 Standard 125 mm (4.92")
 Optional 250 mm (9.84") or
 400 mm (15.75")

Flanged process connection

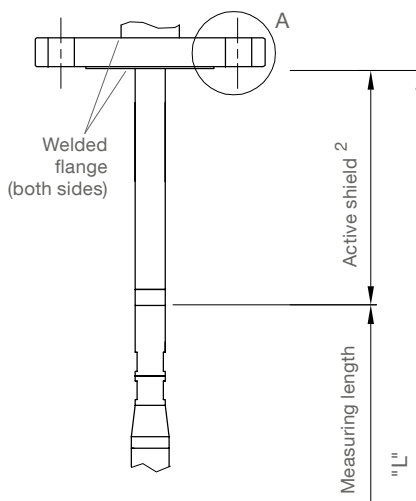

Detail "A"

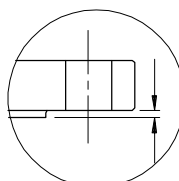

"L" does not include any raised face (see page 13)

² Coated with PFA
 Standard 105 mm (4.13")
 Optional 230 mm (9.06") or
 380 mm (14.96")

Dimensions/ Detailed Ex-markings

Flanges

	Code	Type	Number of holes	d2 mm (inch)	Lk mm (inch)	D mm (inch)	T thickness mm (inch)
ASME B16.5, raised face	5A	1" 150 lbs	4	15.9 (0.63)	79.3 (3.12)	108.0 (4.25)	14.3 (0.56)
	5B	1" 300 lbs	4	19.1 (0.75)	88.9 (3.5)	123.8 (4.87)	17.5 (0.69)
	5C	1" 600 lbs	4	19.1 (0.75)	88.9 (3.5)	123.8 (4.87)	17.5 (0.69)
	5D	1½" 150 lbs	4	15.9 (0.63)	98.6 (3.88)	127.0 (5.0)	17.5 (0.69)
	5E	1½" 300 lbs	4	22.2 (0.87)	114.3 (4.5)	155.6 (6.13)	20.6 (0.81)
	5F	1½" 600 lbs	4	22.2 (0.87)	114.3 (4.5)	155.6 (6.13)	22.4 (0.88)
	5G	2" 150 lbs	4	19.1 (0.75)	120.7 (4.75)	152.4 (6.01)	19.1 (0.75)
	5H	2" 300 lbs	8	19.1 (0.75)	127.0 (5.0)	165.1 (6.5)	22.2 (0.87)
	5J	2" 600 lbs	8	19.1 (0.75)	127.0 (5.0)	165.1 (6.5)	25.4 (1.0)
	5K	3" 150 lbs	4	19.1 (0.75)	152.4 (6.01)	190.5 (7.5)	23.9 (0.94)
	5L	3" 300 lbs	8	22.2 (0.87)	168.2 (6.62)	209.6 (8.25)	28.6 (1.13)
	5M	3" 600 lbs	8	22.2 (0.87)	168.2 (6.62)	209.6 (8.25)	31.7 (1.25)
	5N	4" 150 lbs	8	19.1 (0.75)	190.5 (7.5)	228.6 (9.0)	23.9 (0.94)
	5P	4" 300 lbs	8	22.2 (0.87)	200.0 (7.87)	254.0 (10.0)	31.7 (1.25)
5Q	4" 600 lbs	8	25.4 (1.0)	215.9 (8.5)	273.1 (10.75)	38.1 (1.5)	
EN 1092-1 type A, flat faced	6A	DN25 PN16	4	14.0 (0.55)	85.0 (3.35)	115.0 (4.53)	18.0 (0.71)
	6B	DN25 PN40	4	14.0 (0.55)	85.0 (3.35)	115.0 (4.53)	18.0 (0.71)
	6C	DN40 PN16	4	18.0 (0.71)	110.0 (4.33)	150.0 (5.91)	18.0 (0.71)
	6D	DN40 PN40	4	18.0 (0.71)	110.0 (4.33)	150.0 (5.91)	18.0 (0.71)
	6E	DN50 PN16	4	18.0 (0.71)	125.0 (4.92)	165.0 (6.5)	18.0 (0.71)
	6F	DN50 PN40	4	18.0 (0.71)	125.0 (4.92)	165.0 (6.5)	20.0 (0.79)
	6G	DN80 PN16	8	18.0 (0.71)	160.0 (6.3)	200.0 (7.87)	20.0 (0.79)
	6H	DN80 PN40	8	18.0 (0.71)	160.0 (6.3)	200.0 (7.87)	24.0 (0.94)
	6J	DN100 PN16	8	18.0 (0.71)	180.0 (7.09)	220.0 (8.66)	20.0 (0.79)
	6K	DN100 PN40	8	22.0 (0.87)	190.0 (7.48)	235.0 (9.25)	24.0 (0.94)

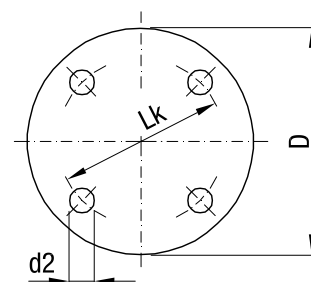

Raised face

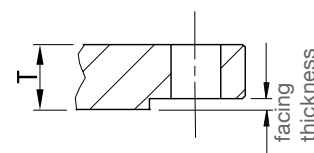

Type	Facing thickness
ASME 150 lbs ASME 300 lbs	2 mm (0.08")
ASME 600 lbs	7 mm (0.28")

Detailed Ex-markings

pos.2	Certificate	Protection method
T	ATEX II 1/2G ATEX II 1/2D Ex ia/db [ia Ga] IIC T ⚠ Ga/Gb Ex ia/tb [ia Da] IIIC T ⚠ Da/Db	Flameproof, Dust Ignition Proof
Y	ATEX II 1G ATEX II 1/2D Ex ia IIC T ⚠ Ga Ex ia IIIC T ⚠ Da/Db	Intrinsically Safe
W	ATEX II 1/2D Ex ia/tb [ia Da] IIIC T ⚠ Da/Db	Dust Ignition Proof
U	FM/ CSA XP-AIS Class I, Div.1, Gr. A, B, C, D DIP-AIS Class II, Div.1, Gr. E, F, G DIP-AIS Class III T4	Explosion Proof, Dust Ignition Proof
P	FM/ CSA IS Class I, Div.1, Gr. A, B, C, D IS Class II, Div.1, Gr. E, F, G IS Class III T4	Intrinsically Safe
N	FM/ CSA DIP-AIS Class II, Div.1, Gr. E, F, G DIP-AIS Class III T4	Dust Ignition Proof
D	INMETRO Ex d [ia Ga] IIC T6...T1 Gb Ex tb IIIC T85°C... 100°C Db IP65/IP68	Flameproof, Dust Ignition Proof

Electrical installation

Standard

Relay SPDT/
 Solid state switch

Power supply:

12 .. 250 V AC/ DC (0 .. 60 Hz)
 2 W max.

Signal output:

Relay:
 Floating relay SPDT
 AC max. 250 V, 8 A, 2000 VA, non inductive
 DC max. 30 V, 5 A, 150 W, non inductive

Solid state switch:
 30 V DC or 30 V AC (peak), 82 mA
 Observe protection (see below)

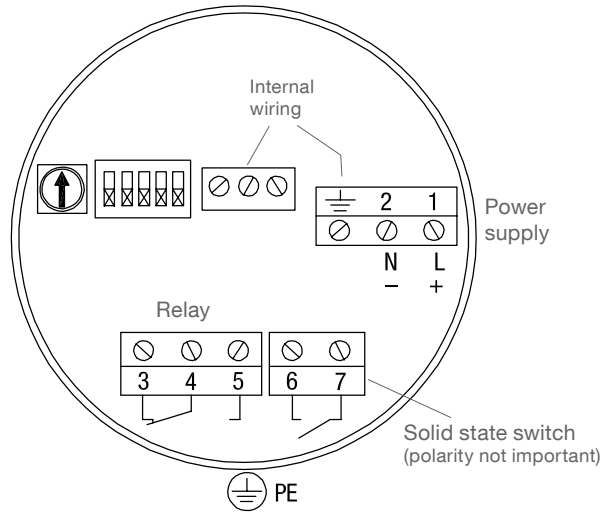

Digital

Profibus PA/
 Solid state switch

Power supply:

12 .. 30 V DC, 12.5 mA

Intrinsically Safe:
 12 .. 24 V DC, 12.5 mA
 Intrinsically safe barrier required
 For ATEX:

$U_i = 24\text{ V}$ $I_i = 380\text{ mA}$ $P_i = 5.32\text{ W}$ $C_i = 5\text{ nF}$ $L_i = 10\text{ uH}$

For FM/ CSA:
 See "Connection drawing" in the
 Instruction Manual

Signal output:

Solid state switch:
 30 V DC or 30 V AC (peak), 82 mA
 Observe protection (see below)

With Intrinsically safe:
 Intrinsically safe barrier required

For ATEX: $U_i = 30\text{ V}$ $I_i = 200\text{ mA}$ $P_i = 350\text{ mW}$ $C_i = 0$ $L_i = 0$

For FM/ CSA:
 See "Connection drawing" in the Instruction Manual

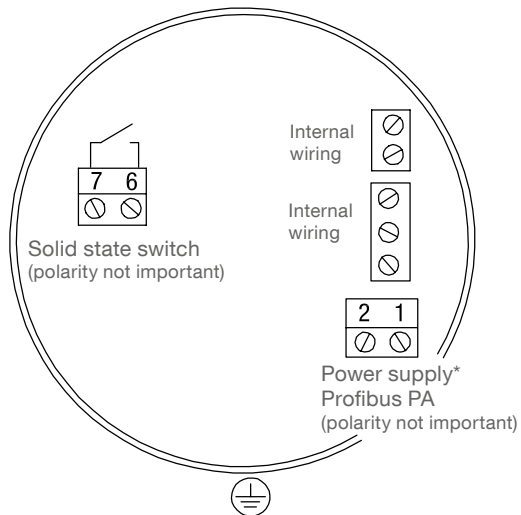

* With use of Profibus the wiring must be according to Profibus PA standards. If Profibus is not used, a shielded cable is recommended to ensure stable measurement.

Protection of Solid State Switch

Observe a Protection diode in case of connecting an external relay to the Solid state switch.

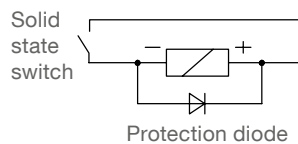

Spare parts

Minimum order value for separate orders of spare parts or accessories is 75 €.

Fitting to model code	Spare part Article number
-----------------------	---------------------------

Electronic module

Standard: Relay SPDT/ Solid State 12 ... 250 V AC/ DC
 Digital: Profibus PA/ Solid State 12 ... 30 V DC (24 V intrinsic safe) LCD display

Electronic module Standard	For all rod versions and for rope version "L"≤5 m	pos.4 E	pl440200	•
Electronic module Standard	For rope version "L">5 m	pos.4 E pos.8 Q,Z (>5 m)	pl440210	•
Electronic module Digital	For all rod versions and for rope version "L"≤5 m	pos.4 F	pl440220	•
Electronic module Digital	For rope version "L">5 m	pos.4 F pos.8 Q,Z (>5 m)	pl440230	•
Internal Safety barrier (required for Ex approvals)		pos.4 E,F pos.2 T,W,U,N,D	pl440060	•

Rod extension kit

1.4404 (SS316L), including fixing parts. Rod can be shortened by customer.
 Stated Length of extension "L" is with use of active shield length 125 mm.
 If required the rod extension kit can simply be mounted on a unit where a rope extension is present.

"L"=350 mm (13.8")	Rod length=180 mm (7.1")	pos.8 A	zu440010	•
"L"=500 mm (19.7")	Rod length=330 mm (13.0")	pos.8 B	zu440020	•
"L"=750 mm (29.5")	Rod length=580 mm (22.8")	pos.8 C	zu440030	•
"L"=1,000 mm (39.4")	Rod length=830 mm (32.7")	pos.8 D	zu440040	•

Rope extension kit

1.4404 (SS316L), including fixing parts. Rope can be shortened by customer.
 Stated Length of extension "L" is with use of active shield length 125 mm.
 If required the rope extension kit can simply be mounted on a unit where a rod extension is present.

"L"=1 m (39.4")	Rope not PFA coated	pos.8 P,Q,Z pos.10 2	zu440100	•
"L"=5 m (197")	Rope not PFA coated	pos.8 P,Q,Z pos.10 2	zu440110	•
"L"=10 m (394")	Rope not PFA coated	pos.8 P,Q,Z pos.10 2	zu440120	•
"L"=20 m (787")	Rope not PFA coated	pos.8 P,Q,Z pos.10 2	zu440130	•
"L"=1 m (39.4")	Rope PFA coated	pos.8 P,Q,Z pos.10 3	zu440200	•
"L"=5 m (197")	Rope PFA coated	pos.8 P,Q,Z pos.10 3	zu440210	•
"L"=10 m (394")	Rope PFA coated	pos.8 P,Q,Z pos.10 3	zu440220	•
"L"=20 m (787")	Rope PFA coated	pos.8 P,Q,Z pos.10 3	zu440230	•

Rope weight

Single part, 1.4404 (SS316L), for use with rope not PFA coated and PFA coated	pos.8 P,Q,Z	zu440350	•
---	-------------	----------	---

Electronic module Standard

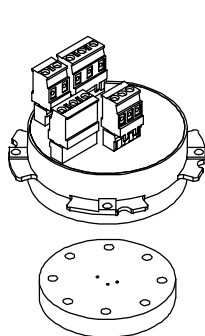

Electronic module Digital

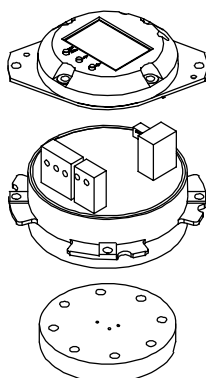

Internal Safety barrier

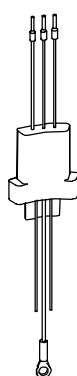

Rod extension kit



Rope extension kit

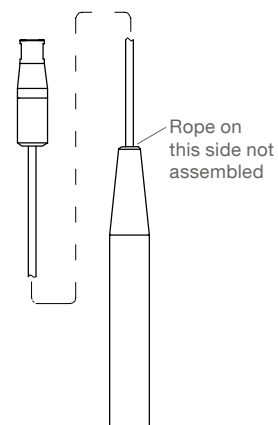

Rope weight

