



## THYRO-P

THYRISTOR-LEISTUNGSSTELLER / THYRISTOR POWER CONTROLLER

KOMMUNIKATIONSFÄHIG / COMMUNICATION CAPABLE

October 2014 8000003232 DE/EN - V9







## THYRO-P

THYRISTOR-LEISTUNGSSTELLER / THYRISTOR POWER CONTROLLER

KOMMUNIKATIONSFÄHIG / COMMUNICATION CAPABLE

October 2014 8000003232 DE/EN - V9



## SAFETY INSTRUCTIONS

**THE SAFETY INSTRUCTIONS AND OPERATING MANUAL ARE TO BE CAREFULLY READ PRIOR TO INSTALLATION AND COMMISSIONING.**

### OBLIGATION TO GIVE INSTRUCTIONS

The following safety and operating instructions must be carefully read before assembly, installation and commissioning of Thyro-P by those persons working with or on Thyro-P.

These operating instructions are part of the Power Controller Thyro-P.

The operator of this device is obliged to provide these operating instructions to all persons transporting, commissioning, maintaining or performing other work on the Thyro-P without any restrictions.

In accordance with the Product Liability Act, the manufacturer of a product has an obligation to provide explanations and warnings as regards:

- the use of the product other than for the intended use,
- the residual product risk and
- operating error and its consequences.

The information given below must be understood in this respect. It is to warn the product user and protect him and his systems.

### PROPER USE

- The Thyristor Power Controller is a component which may only be used for control and regulation of electrical energy in industrial alternating current or 3-phase networks.
- The Thyristor Power Controller may at maximum be operated using the maximum admissible connected load according to information on the type plate.
- The Thyristor Power Controller may only be operated in connection with a suitable and series connected power supply disconnecting device.
- As a component the Thyristor Power Controller is unable to operate alone and must be projected for its intended use to minimize residual risks.
- The Thyristor Power Controller may only be operated in the sense of its intended use; otherwise, personal hazards (for instance electrical shock, burns) and hazards for systems (for instance overload) may be caused.

### RESIDUAL HAZARDS OF THE PRODUCT

- Even in case of proper use, in case of fault, it is possible that control of currents, voltages and power is no longer performed in the load circuit by the Thyristor Power Controller.

In case of destruction of the power components (for instance breakdown or high resistance), the following situations are possible: power interruption, half-wave operation, continuous power flow. If such a situation occurs, then load voltages and currents are produced from the physical dimensions of the overall power circuit. It must be ensured by system design that no uncontrolled large currents, voltages or power results. It is not possible to totally exclude that during operation of Thyristor power controllers other loads show abnormal behavior. The physically determined network reactions, depending on the operating mode, must be considered.

### DANGER OF ELECTRIC SHOCKS

Even if the Thyristor Power Controller is not triggered, the load circuit is not disconnected from the mains.

It is possible to safely disconnect the Thyristor Power Controller as under IEC 60950

## MALOPERATION AND THE RESULTS

With maloperation, it is possible that power, voltage or current levels which are higher than planned reach the Thyristor Power Controller or load. On principle, this can lead to the Power Controller or load being damaged. It is important that preset parameters are not adjusted in any way that may cause the Power Controller to overload.

## TRANSPORT

Thyristor Power Controllers are only to be transported in their original packaging (protection against damage, e.g. due to impact, being knocked, soiling).

## INSTALLATION

- If the Thyristor Power Controller is brought into the operations room from a cold environment, moisture can occur. Prior to it being commissioned, the Thyristor Power Controller must be absolutely dry. For this reason, wait for a minimum period of two hours before commissioning.
- Install the device upright.

## CONNECTION

- Prior to connection, it must be ensured that the voltage information on the type plate corresponds with the mains voltage.
- The electrical connection is carried out at the designated points with the required cross section and the appropriate screw cross sections.

## OPERATION

- The Thyristor Power Controller may only be connected to the mains voltage if it has been ensured that any hazard to people and system, especially in the load section, has been eliminated.
- Protect the device from dust and moisture.
- Do not block vents.

## MAINTENANCE, SERVICE, MALFUNCTIONS

The icons used below are explained in the chapter safety regulations.

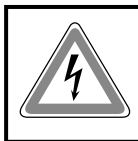

### CAUTION

Should smoke, smell or fire occur the Power Controller must be disconnected from the mains immediately.

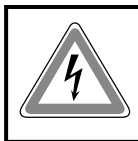

### CAUTION

For maintenance and repair work, the Power Controller must be disconnected from all external voltage sources and protected against restarting. Make sure to wait minimum 1 minute after switch-off (discharge time of the attenuation capacitors). The voltage-free state is to be determined by means of suitable measuring instruments. This work is only to be carried out by a skilled electrician. The electrical regulations which are locally valid are to be adhered to.



### CAUTION

The Thyristor Power Controller contains hazardous voltages. Repairs may generally only be performed by qualified and trained maintenance personnel.

**CAUTION**

Hazard of electrical shock. Even after disconnection from the mains voltage, capacitors may still contain a dangerously high power level.

**CAUTION**

Hazard of electrical shock. Even when the Thyristor Power Controller is not triggered, the load circuit is not disconnected from the mains.

**ATTENTION**

Different components in the power section are screwed in place using exact torques. For safety reasons, power components repairs must be performed by Advanced Energy Industries GmbH.

# TABLE OF CONTENTS

Safety instructions	2
List of illustrations and tables	7
Safety regulations	8
Remarks on the present operating instructions and Thyro-P	11
1. Introduction	13
1.1 General	13
1.2 Specific characteristics	13
1.3 Type designation	14
2. Functions	15
2.1 Operating modes	15
2.2 Set point control characteristic	16
2.3 Control types	19
2.3.1 Controlled value	19
2.4 Indications	20
2.4.1 LED indications	20
2.4.2 Relay indications K1-K2-K3	20
2.5 Monitoring	21
2.5.1 Monitoring of mains voltage	21
2.5.2 Load monitoring	22
2.5.2.1 Absolute value monitoring current	22
2.5.2.2 Relative monitoring	22
2.5.2.3 Overview monitoring	25
2.5.3 Fast current monitoring	25
2.5.4 Fan monitoring	26
3. Operation	27
3.1 Local operating and control unit LBA-2	27
3.2 LBA-2 tool	31
3.3 Cabinet installation kit (SEK)	36
3.4 Thyro-Tool Family	36
3.5 Error acknowledgement / Data logger	37
3.6 LBA-2 menu structure	40
4. External connections	45
4.1 Power supply for Thyro-P	45
4.2 Power supply for the control device A70	45
4.3 Power supply for the ventilator	46
4.4 RESET	46
4.5 Controller inhibit	46
4.6 QUIT	46
4.7 Set point value inputs	47
4.8 ASM input	47
4.9 dASM input – dASM output	47
4.10 Analog outputs	47
4.11 Current transformer	48
4.12 Voltage transformer	50
4.13 Other connections and terminal strips	51
4.14 Synchronization	53
4.15 Component mounting diagram control device	54
5. Interfaces	55
5.1 RS232 interface	56
5.2 Fiber optic interface	57
5.2.1 Fiber optic distribution system	57

5.3	Bus interfaces (optional)	60
6.	Mains load optimization for operating mode TAKT	61
6.1.	dASM mains load optimization	61
6.2	SYT-9 procedure	67
6.3	Software synchronization	67
6.3	ASM procedure (patented)	68
7.	Mains load optimization VSC	69
8.	Connecting diagrams	71
9.	Special Remarks	79
9.1	Installation	79
9.2	Protection against contact IP20	79
9.3	Commissioning	80
9.4	Service	80
9.5	Checklist	80
10.	Type Overview	82
10.1	Type range 400 Volt	82
10.2	Type range 500 Volt	83
10.3	Type range 690 Volt	85
11.	Technical data	86
12.	Dimensional Drawings	90
13.	Accessories and Options	103
14.	Approvals and Conformities	104

## LIST OF ILLUSTRATIONS AND TABLES

Fig. 1	Control characteristic for U control	17
Fig. 2	Total set point	18
Fig. 3	Switch-on fault bridging	21
Fig. 4	Absolute value monitoring	22
Fig. 5	Relative monitoring	22
Fig. 6	Start screen LBA-2	27
Fig. 7	Main menu LBA-2 (sample)	28
Fig. 8	Example entries LOG file	29
Fig. 9	Access levels	30
Fig. 10	Language selection	33
Fig. 11	Folder selection	33
Fig. 12	Calendar navigation	33
Fig. 13	Calendar navigation with no LOG files found	33
Fig. 14	Standard zoom keys	34
Fig. 15	Y scaling panel	34
Fig. 16	Value panel	35
Fig. 17	Event panel details	35
Fig. 18	Example calendar	35
Fig. 19	Example for user interface Thyro-Tool Family	36
Fig. 20	Component mounting diagram control device	54
Fig. 21	Interfaces of Thyro-P	55
Fig. 22	Connection of a PC to Thyro-P via RS232	56
Fig. 23	X10 allocation	57
Fig. 24	Signal converter RS232 / fiber optic	58
Fig. 25	Schematic diagram fiber optic Thyro-P with LLV and PC	59
Fig. 26	Wiring of the dASM signal cables	62
Fig. 27	LEDs on the RJ45 connectors	62
Fig. 28	ASM wiring	68
Tab. 1	Behavior in case of load change	20
Tab. 2	Partial load breakdown with heating elements switched in parallel, undercurrent, relative monitoring	23
Tab. 3	Partial short-circuit with heating elements switched in series, overcurrent, relative monitoring	24
Tab. 4	Overview monitoring	25
Tab. 5	Error and data logger messages	39
Tab. 6	LBA-2 menu structure	40
Tab. 7	Terminal strip X1	45
Tab. 8	RESET	46
Tab. 9	Controller lock	46
Tab. 10	QUIT	47
Tab. 11	Current transformer	48
Tab. 12	Voltage transformer	50
Tab. 13	Voltage measurement jumper	50
Tab. 14	Terminal strip X2 for K1, K2, K3	51
Tab. 15	Terminal strip X5 in the control device	52
Tab. 16	Terminal strip X6	52
Tab. 17	Terminal strip X7	53
Tab. 18	Synchronization jumper	53
Tab. 19	Fiber optic distances	58

## SAFETY REGULATIONS

### IMPORTANT INSTRUCTIONS AND EXPLANATIONS

Operation and maintenance according to regulation as well as observance of the listed safety regulations is required for protection of the staff and to preserve readiness to operate. Personnel installing/uninstalling the devices, commissioning them, operating them, maintaining them must know and observe these safety regulations. All work may only be performed by specialist personnel trained for this purpose using the tools, devices, test instruments and consumables provided for this purpose and in good shape.

In the present operating instructions, important instructions are marked using the terms „CAUTION“, „ATTENTION“ and „REMARK“ as well as using the icons explained below.

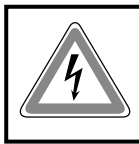

#### CAUTION

This instruction shows work and operating procedures to be observed exactly to exclude hazards for persons.



#### ATTENTION

This instruction refers to work and operating procedures to be observed exactly to avoid damage or destruction of Thyro-P or parts thereof.

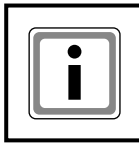

#### REMARK

This is where remarks about technical requirements and additional information is given, which the user has to observe.

### ACCIDENT PREVENTION RULES

The accident prevention rules of the application country and the generally applicable safety regulations must be observed in any case.

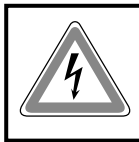

#### CAUTION

Before starting any work on Thyro-P, the following safety regulations must be observed:

- switch voltage-free,
- secure against switching on,
- determine if it is voltage-free,
- ground and short-circuit it,
- cover or block neighboring parts under voltage.

### QUALIFIED PERSONNEL

Thyro-P may only be transported, installed, connected, commissioned, maintained and operated by specialists in command of the respective applicable safety and installation regulations. All work must be monitored by the responsible specialist personnel. The specialist personnel must be authorized for the work required by the person responsible for the safety of the system.

Specialists are persons who

- have received training and have experience in the respective field of work,
- know the respective applicable standards, regulations, terms and accident prevention rules,
- have been familiarized with the function and operating conditions of Thyro-P,
- are able to detect and avoid hazards.

## WORK OBSERVING SAFETY REGULATIONS

Before removing safety installations for performance of maintenance and repair work or other work, measures due to operation must be initiated.

Work observing safety regulations also means to point out faulty behavior to colleagues and to notify the office or person responsible about defects detected.

## INTENDED USE



### CAUTION

The Thyristor Power Controller may only be employed in the sense of its purpose of use (see the section of the chapter safety instructions under the same name), otherwise hazards for persons (for instance electrical shock, burns) and systems (for instance overload) may occur.

Any unauthorized reconstruction and modification of Thyro-P, use of spare and exchange parts not approved by Advanced Energy Industries as well as any other use of Thyro-P is not allowed. The person responsible for the system must ensure that

- hints on safety and operating instructions are available and observed,
- operation conditions and specifications are observed,
- protective installations are used,
- required maintenance work is performed,
- maintenance personnel are immediately notified or Thyro-P is immediately put out of commission if abnormal voltages or noises, higher temperatures, vibrations or similar occur to determine the causes.

These operating instructions contain all information required by specialists for use of Thyro-P. Additional information and hints for unqualified persons and for use of Thyro-P outside of industrial installations are not contained in these operating instructions.

The warranty obligation of the manufacturer applies only if these operating instructions are observed.

## LIABILITY

In case of use of Thyro-P for applications not provided for by the manufacturer, no liability is assumed. The responsibility for required measures to avoid hazards to persons and property is borne by the operator respectively the user. In case of complaints, please immediately notify us stating:

- type name,
- production number,

- objection,
- duration of use,
- ambient conditions,
- operating mode.

## GUIDELINES

The devices of the type range Thyro-P conform to the currently applicable EN 50178 and EN 60146-1-1.

The CE mark on the device confirms observation of the general EG guidelines for 2006/95/EC (LVD) – low voltage and for 2004/108/EC (EMC) – electromagnet compatibility, if the instructions on installation and commissioning described in the operating instructions are observed.

Regulations and definitions for qualified personnel are contained in DIN 57105/VDE 0105 Part 1.

Safe isolation to VDE 0160 (EN 50178 Chapter 3)

## REMARKS ON THE PRESENT OPERATING INSTRUCTIONS AND THYRO-P

### VALIDITY

These operating instructions refer to latest technical specification of Thyro-P at the time of publication and are for information purposes only. Every effort has been taken to ensure the accuracy of this specification, however, in order to maintain our technological lead and for product enhancement, we are continually improving our products which could, without notice, result in amendments or omissions to this specification. Advanced Energy Industries cannot accept responsibility for damage, injury, loss or expenses resulting therefrom.

### HANDLING

These operating instructions for Thyro-P are organized so that all work required for commissioning, maintenance and repair may be performed by corresponding specialist personnel.

If hazards to personnel and property cannot be excluded for certain work, then this work is marked using certain icons. The meaning of these icons may be found in the prior chapter safety regulations.

### ABBREVIATIONS

In this description, the following specific abbreviations are used:

AEI	=	Advanced Energy Industries GmbH
dASM	=	digital mains load optimization, dynamic
ASM	=	automatic synchronization in multiple power controller applications (dynamic mains load optimization, not for new installations)
LBA-2	=	Local operating and display unit with touch display
LBA	=	Local operating and display unit (not for new installations)
SEK	=	cabinet installation kit
LL	=	fiber optic
LLS	=	fiber optic transmitter
LLE	=	fiber optic receiver
LLV.V	=	fiber optic distribution supply
LLV.4	=	fiber optic distribution, 4-fold
MOSI	=	heating system for molybdenum discilicide
SP	=	set point
SYT	=	synchronized clock

### WARRANTY

Customer shall provide written particulars, enclosing the delivery note, within 8 working days to Advanced Energy Industries on becoming aware of any defects in the goods during the Warranty period and shall use

its best endeavors to provide Advanced Energy Industries with all necessary access, facilities and information to enable Advanced Energy Industries to ascertain or verify the nature and cause of the defect and carry out its warranty obligations.

If goods are found not to be defective or if any defect is attributable to Customer's design or material in operation of the goods, Advanced Energy Industries will levy a testing charge and where relevant will return the

goods to Customer at Customer's expense, and shall be entitled to payment in advance of the whole testing and transport charge before such return.

Advanced Energy Industries accepts no liability for defects caused by the Customer's design or installation of the goods; or if the goods have been modified or repaired otherwise than as authorized

in writing by Advanced Energy Industries; or if the defect arises because of the fitting of the goods to unsuitable equipment.

Advanced Energy Industries will cancel all possible obligations incurred by Advanced Energy Industries and its dealers, such as warranty commitments, service agreements, etc., without prior notice if other than original AEI spare parts or spare parts purchased from Advanced Energy Industries are used for maintenance or repair.

## CONTACT

### TECHNICAL QUERIES

If you have any technical queries regarding the subjects dealt with in these operating instructions, please get in touch with our team for power controllers:

Phone: +49 (0) 2902 763 -520 or

Phone: +49 (0) 2902 763 -290

powercontroller@aei.com

### COMMERCIAL QUERIES

If you have any commercial queries on power controllers, please get in touch with:

Phone: +49 (0) 2902 763 -558

powercontroller@aei.com

## ADDRESS

Advanced Energy Industries GmbH

Branch office Warstein-Belecke

Emil-Siepmann-Straße 32

D-59581 Warstein

Phone: +49 (0) 2902 763-0

## INTERNET

Further information on our company or our products can be found on the internet under [www.advanced-energy.com](http://www.advanced-energy.com)

## COPYRIGHT

Passing on, duplication and/or takeover of these operating instructions using electronic or mechanical means, even in excerpts, is subject to express prior written approval of Advanced Energy Industries.

© Copyright Advanced Energy Industries. All rights reserved.

### COPYRIGHT NOTICE

Thyro-P is an internationally registered trademark of Advanced Energy Industries.

Windows and Windows NT are registered trademarks of Microsoft Corporation.

All other company and product names are (registered) trademarks of their respective owners.

# 1. INTRODUCTION

For transport, assembly, installation, commissioning, operation and decommissioning, the safety instructions contained in these operating instructions must be applied in any case and made available to all persons handling this product.



## CAUTION

It is important that preset parameters are not adjusted in any way that may cause the Power Controller to overload. In case of uncertainties or missing information, please contact your supplier.

## 1.1 GENERAL

Thyro-P is a communication enabled SCR thyristor power controller. Below, it is also referred to simply as power controller. The Thyro-P power controller can be installed everywhere where voltages, currents or power have to be controlled precisely in 1- or 3-phase networks. Several modes of operation and control, good coupling ability to process and automation technology, high control precision by application of a 32 bit processor and simple handling ensure that Thyro-P is also suitable for new applications.

Thyro-P offers new ways for mains load optimization:

- In operating mode TAKT, the optional digital mains load optimization of dASM ensures that multiple power controller applications can be used in an optimal way for the network so that system perturbations are mainly avoided.
- For applications which have to use phase angle firing due to required high dynamic, Thyro-P..VSC offers to minimize significantly harmonics by its VSC technology.

Thyro-P is suitable in particular for

- direct supply of ohmic loads
- for loads with large  $R_{hot}/R_{cold}$  ratio
- as primary power controller for a transformer with subsequent load

Due to use of high quality thyristors, the Thyristor Power Controller Thyro-P has a type range up to 2900A, the nominal design loads reach up to about 2860kW.

## 1.2 SPECIFIC CHARACTERISTICS

Thyro-P is characterized by a multitude of specific characteristics, for instance:

- easy handling
- menu-driven user interface (options: LBA-2 with touch display, Thyro-Tool Family)
- type range 230-690 Volts, 5-2900A, single, double, triple phase
- broadband power supply AC 200-500V, 45-65Hz
- ohmic load and transformer load
- as well as load with large  $R_{hot}/R_{cold}$  for 1P and 3P
- soft start function for transformer load
- load circuit monitoring
- automatical rotating field recognition for 2P and 3P
- U,  $U^2$ , I,  $I^2$ , P control as well as without control
- operating modes TAKT, VAR, VSC\_VAR, SSSD, MOSI (optional sub operating mode of TAKT and VAR)
- mains load optimization dASM for applications with multiple power controllers in operating mode TAKT
- control of analog set points or via interfaces
- fiber optic and RS232 interfaces as standard
- electrical separation according to EN 50178 chap. 3

- Measured values are given at analog outputs
- 4 set point channels incl. motor potentiometer to set parameters

The specific characteristics especially include the following options:

- LBA-2 local touch display with integrated process data recorder of up to 6 channels
- LBA-2 is downward compatible with LBA and can replace it.
- Cabinet installation kit (SEK) for LBA-2 with touch display. The SEK allows the installation of LBA-2 in cabinet doors. It comes with wiring and installation frame.
- Bus connection via bus adaptor cards to plug into the Thyro-P Power Controller, coupling to different bus systems, for instance Profibus, other bus systems upon enquiry.
- The PC-Software Thyro-Tool Family for effective commissioning and simple visualization tasks. Functions are for instance loading, storing, modification, comparing and printing of parameters, set points and actual value processing, line diagrams of process data (including printing and storing option), bar diagrams, simultaneous display of process data from different power controllers, simultaneous connection of up to 998 Thyro-P Power Controllers.
- Patented ASM procedure for dynamic mains load optimization. The ASM procedure (automated synchronization of multiple power controller applications) is used for dynamic mains load optimization. It reacts to changes in load and set point, minimizes mains load peaks and associated mains feedback. Minimizing of mains load peaks means cost savings in operating and investment cost.
- For new systems it is recommended to use the high performance dASM instead of ASM.

#### NOTE:

After purchasing Thyro-Tool Family software updates (if available) can be downloaded for free from our homepage.

### 1.3 TYPE DESIGNATION

The type designation of the thyristor power controllers are derived from the construction of its power section:

TYPE RANGE	DESIGNATION	FEATURES
Thyro-P	1P	1-phase power section, for single phase operation
	2P	2-phase power section 3-phase loads in thress phase economic circuit (not for phase-angle firing VAR)
	3P	3-phase power section, for three phase operation
	.P400	Type voltage 230-400 Volt, 45-65 Hz
	.P500	Type voltage 500 Volt, 45-65 Hz
	.P690	Type voltage 690 Volt, 45-65 Hz
	.P ...-0037	Type current 37A (Typecurrent range 5A-2900 A)
	.. ...-.... . H	Integrated semi-conductor fuse (all Thyro-P)
	.. ...-.... . F	Forced air cooling with integrated ventilators
The complete type range can be found in the TYPE OVERVIEW in chapter 10.		

## 2. FUNCTIONS

For optimum adjustment to different products and production processes as well as differently electrical loads, the most favorable operating and control modes may be set according to the following overview.

### 2.1 OPERATING MODES

This chapter gives an overview of the different operating modes.

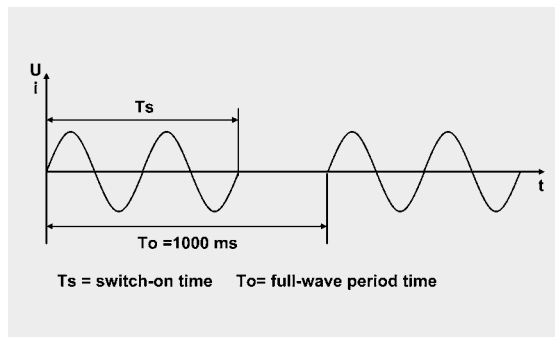

#### FULL WAVE SWITCH (TAKT)

Depending on the prescribed set point, the mains voltage is periodically switched. In this operating mode, almost no harmonics are created. Whole multiples of the mains periods are switched. The operating mode „full wave switch“ is especially suited for loads with thermal inertia. For mains load optimization the optional feature dASM or the optional ASM feature (not for new installations) can be used with this operating mode.

For operating mode TAKT, also SSSD ramp can be used. This is useful in case of switching on a transformer. The SSSD ramp will only be used once after reset or impulse inhibit.

Key parameters are

TAKT cycle period $T_0$	[sec]
Soft-Start SST	[msec]
Soft-Down SDN	[msec]

#### PHASE-ANGLE FIRING (VAR, WITH 1P AND 3P)

Depending on the prescribed set point, the sine oscillation of the mains voltage is gated using a larger or smaller control angle  $\alpha$ . This operating mode is characterized by high control dynamics. In operating mode phase-angle firing, it is possible to compensate harmonics of the mains voltage by using circuit variants (e.g. vector group transformer).

To prevent sudden changes of modulation, SSSD feature can be used. It works as a restrictor for peaks.

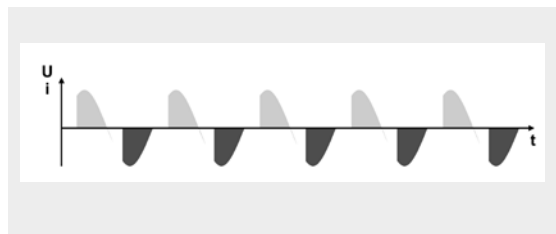

Key parameters are

Soft-Start SST	[msec]
Soft-Down SDN	[msec]

### SOFT-START-SOFT-DOWN (SSSD)

The operating mode SSSD operated similar to operating mode TAKT. However, it can be used especially advantageous in operation of large single loads to reduce pulse-shaped mains loads and therefore to reduce voltage variations. Switching on and off of turn on-time  $T_s$  occurs by applying periods with phase-angle firing (VAR). Please see following diagram.

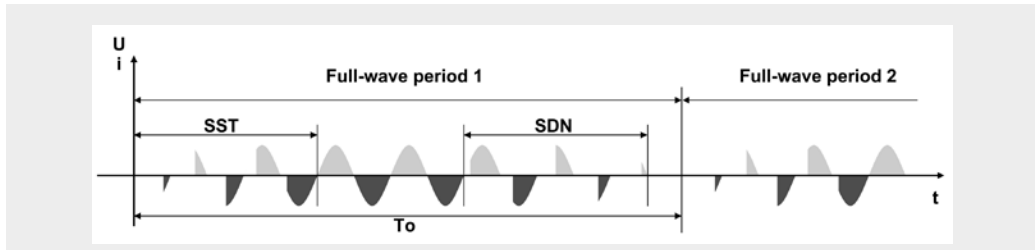

Key parameters are

TAKT cycle period $T_0$	[sec]
Soft-Start SST	[msec]
Soft-Down SDN	[msec]

### MOSI operation for 1P and 3P

MOSI is a sub-operating mode of the operating modes TAKT and VAR for sensitive heating materials with a high  $R_{hot}/R_{cold}$  ratio, for instance molybdenum disilicide. The Power Controller always starts with phase-angle maximum value and actual value to avoid high current amplitudes during the heating-up phase and then automatically switches to the set operating mode.

For the sub-operating mode MOSI, the key parameters are:

MOSI:	RAMP/ STELL
Rate of angular displacement 1	[°el/s]
Rate of angular displacement 2	[°el/s]
Peak current	
$I_{max}$	[A]

### MAINS LOAD OPTIMIZATION (WITH dASM OR OPTIONAL ASM PROCESS)

For systems in which several power controllers are employed in full wave switch mode TAKT, it is possible that individual power controllers are synchronized so that a regular mains load is achieved by defined switching of the individual power controller. This avoids load peaks by random simultaneous switching of many power controllers and load troughs are filled up. The upstream transformer and/or the upstream feed point may be designed for a lower load. Besides savings in investment and operating costs it also results in considerable lower system perturbations.

For new installations the dASM process is recommended due to its quicker and easier handling (see chapter 6.1).

## 2.2 SET POINT CONTROL CHARACTERISTIC

The set point control characteristic of Thyro-P may be easily adapted for the control output signal of the upstream process controller or automation system. All signals customary on the market may be used. The adaption is made by changing the starting and ending points of the control characteristic. Inverted operation (ending value is smaller than the starting value in voltage or current) is also possible.

The effective set point is the total set point. It is formed by adding the four set points as shown in fig. 2.

In the simplest case all the set point values are added algebraically. The prerequisite for a set point to influence the total set point value is that it must be enabled by the set point Enable Register.

- Set point 1 (X5.2.10 - X5.1.13 ground) 0-20mA default

- Set point 2 (X5.2.11 - X5.1.13 ground) 0-5V default

The inputs set point 1, 2 are two electrically equal analogue inputs for current or voltage signals, with subsequent A/D converter (resolution 0.025% of the final value), and they may be set to the following signal ranges:

0(4)-20 mA	(R <sub>i</sub> = ca. 250 Ω / max. 24mA)	see ATTENTION
0-5 V	(R <sub>i</sub> = ca. 8,8 kΩ / max. 12V)	
0-10 V	(R <sub>i</sub> = ca. 5 kΩ / max. 12V)	

The following table shall be used for the hardware configuration of the set point inputs (see also FILE COMPONENT MOUNTING DIAGRAM CONTROL DEVICE, figure 10). If the hardware configuration is changed, the Thyro-P parameters must be changed accordingly with the LBA-2 or the Thyro-Tool Family.

#### X221 for Set point input 1

JUMPER X221	Signal range	Set point input 1
closed*	0(4) -20mA	(X5.2.10)
open	0-5V / 0-10V	(X5.2.10)

#### X222 for Set point input 2

JUMPER X222	Signal range	Set point input 2
closed	0(4)-20mA	(X5.2.11)
open*	0-5V / 0-10V	(X5.2.11)

\* default



#### ATTENTION

If the open-circuit voltage of the connected set point exceeds 12V in the 20mA signal range, the set point inputs can be destroyed, if the belonging JUMPER (X221, X222) is open.

Within the stated input ranges, these values with the control characteristic may be adjusted to any common signal characteristic.

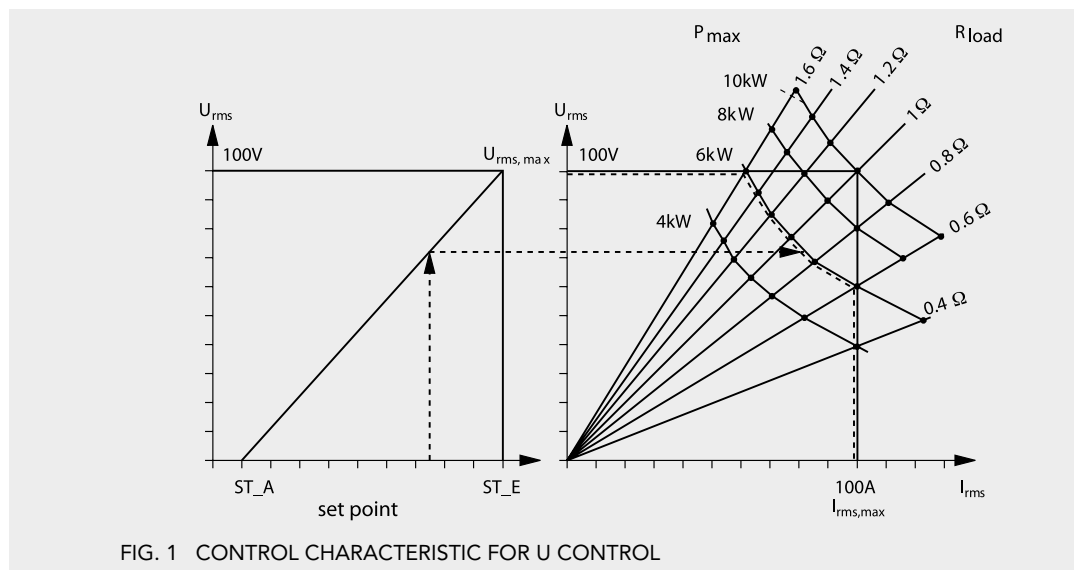

FIG. 1 CONTROL CHARACTERISTIC FOR U CONTROL

For a set point poti (e.g. 5-10 kΩ) 5V supply voltage can be taken from terminal X5.2.5 (R<sub>i</sub> = 220Ω, short-circuit-proof).

**SET POINT CONTROL CHARACTERISTICS**

The set point control characteristic (Fig. 1) of Thyro-P may be easily adapted for the control output signal of the upstream process controller or automation system. All signals customary on the market may be used.

The adaption is made by changing the starting and ending points of the control characteristic. Inverted operation (ending value is smaller than the starting value in voltage or current) is also possible.

- **Set point 3:**

Set point of the superordinate system or PC via RS232 or fiber optic connection (standard) X30, X31 or via the optional bus interface.

- **Set point 4:**

Set point input (motor potentiometer function) settings as for set point 3 but additionally via LBA-2. Set point 4 is stored in case of mains failure.

**EFFECTIVE TOTAL SET POINT VALUE**

The algebraic addition of the results of set point (1,2) to set point 3 and 4 gives the (effective) total set point value for the set point control characteristic as shown in the following figure.

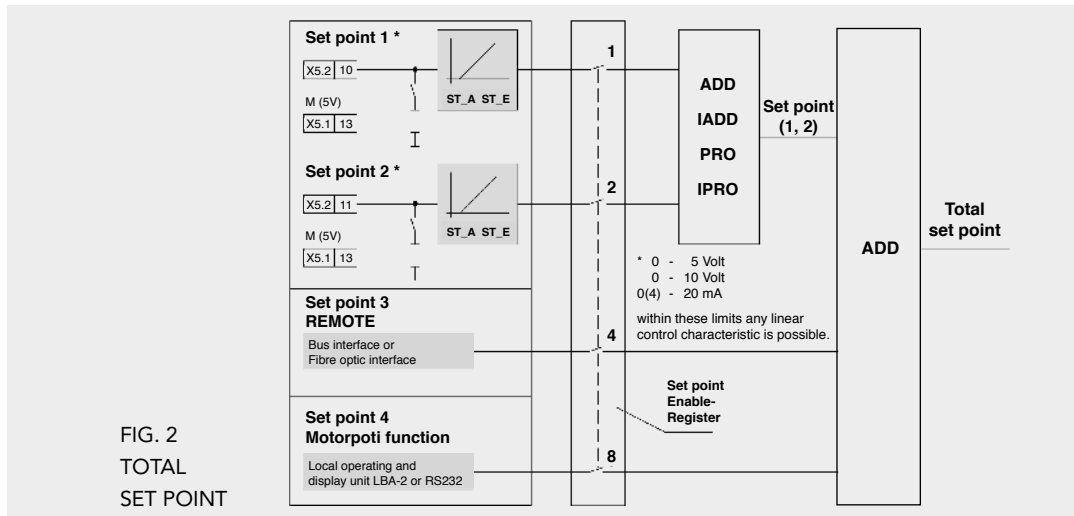

FIG. 2  
TOTAL  
SET POINT

The prerequisite for a set point to influence the total set point value is that it must be enabled by the set point Enable Register. Set point 1 and 2 can be linked using the following functions. The result of this link is called set point (1,2).

**Set point link**

ADD Set point (1,2) = Set point 1 + Set point 2

IADD Set point (1,2) = Set point 1 - Set point 2

\_Pro Set point (1,2) = Set point 1 \*  $\frac{\text{Set point 2 [\%]}}{100\%}$

\_IPro Set point (1,2) = Set point 1 \*  $(1 - \frac{\text{Set point 2 [\%]}}{100\%})$

**VALUE RANGE OF SET POINT (1,2)**

For the link result of set point (1,2) the following value range applies:

$$0 \leq \text{Set point (1,2)} \leq \text{Set point max} (U_{\text{max}}, I_{\text{max}}, P_{\text{max}}).$$

### SET POINT ENABLE REGISTER

The set point Enable Register (AD\_P\_SW\_ENABLE, adr. 94) enables the 4 set points to be shut off or enabled independently. Only enabled set point inputs are part of the effective total set point value.

The shut off or inactive set points are shown by the LBA-2 and can thus, if necessary, be checked before connecting.

The set point Enable Register can be changed from all service units (Bus, Thyro-Tool Family, LBA-2).  
Example:

8	4	2	1	VALUE	ABBR.	EXPLANATION
1	1	1	1	15	STD	Standard (all ON)
1	0	0	0	8	LOC	Motor potentiometer set point 4 (LOCAL)
0	1	0	0	4	REMOTE	Bus set point 3
0	0	1	1	3	ANA	Analog-set points 1,2
0	0	0	0	0		All set points inactive

## 2.3 CONTROL TYPES

Thyro-P has five control types effective as underlying controls. Mains voltage variations and load changes are directly and therefore quickly adjusted by bypassing of the slow temperature control system.

Before commissioning of the power controller and selection of a control type, you should be familiar with the operating procedure respectively the effect for application (further see TAB. 1: BEHAVIOR IN CASE OF LOAD CHANGE in the following chapter).

### 2.3.1 CONTROLLED VALUE

The controlled value effective on the load is proportionate to the total set point, depending on the control type:

CONTROL TYPE	CONTROL VALUE (PROPORTIONATE TO THE TOTAL SET POINT)
P control	output (active) power, P
U control	output voltage, $U_{rms}$
$U^2$ control	output voltage, $U_{rms}^2$
I control	output current, $I_{rms}$
$I^2$ control	output current, $I_{rms}^2$

### LIMITING OF SIGNALS

Independent of the control type set, additionally minimum and maximum limiting values may be set. For this purpose, also refer to Fig. 1 control characteristic.

The maximum limiting values determine the maximum modulation of the load.

The minimum limiting values should ensure minimum modulation via the control angle (for instance minimum heating of the load).

## CONTROLLER RESPONSE

If the load resistance changes, for instance due to temperature effect, ageing or load fault, then the values (depending on control type) effective on the load change as follows:

CONTROL TYPE	LIMIT	LOAD RESISTANCE DECREASES			LOAD RESISTANCE INCREASES			EFFECTIVE* LIMITATIONS	
		P	$U_{LOAD}$	$I_{LOAD}$	P	$U_{LOAD}$	$I_{LOAD}$		
U	$U_{rms\ max}$	larger	=	larger	smaller	=	smaller	$I_{rms\ max}$	$P_{max}$
$U^2 (U \times U)$	$U_{rms\ max}$	larger	=	larger	smaller	=	smaller	$I_{rms\ max}$	$P_{max}$
I	$I_{rms\ max}$	smaller	smaller	=	larger	larger	=	$U_{rms\ max}$	$P_{max}$
$I^2 (I \times I)$	$I_{rms\ max}$	smaller	smaller	=	larger	larger	=	$U_{rms\ max}$	$P_{max}$
P	$P_{max}$	=	smaller	larger	=	larger	smaller	$U_{rms\ max}$	$I_{rms\ max}$
without control		larger	=	larger	smaller	=	smaller	$U_{rms\ max}$ $P_{max}$	$I_{rms\ max}$

\* If one of the limits is exceeded, then the signaling relay K2 and the LED Limit react (default values of parameter settings).

General modulation limit

$$T_s = T_{s\ max}$$

$$\alpha = \alpha_{max}$$

TAB. 1 BEHAVIOR IN CASE OF LOAD CHANGE

## 2.4 INDICATIONS

### 2.4.1 LED INDICATIONS

The LEDs on the front side signal the following states:

- |              |  |
|--------------|--|
| • ON         | green: operating indication, power supply controller board<br>red: RESET active            |
| • CONTROL    | modulation percentage indication, flashing*  |
| • LIMIT      | limitation is active, relay K2 switches*   |
| • PULSE LOCK | Controller Lock active, but load control is continued at pulse limits (default value = 0)* |
| • FAULT      | fault present*   |
| • OVERHEAT   | overheating of power section<br>(in case of ..HF types, check ventilator)*                 |

\* Default setting

Activation of the integrated semiconductor fuse may be signaled using the fault indicating relay K1 (rest current, contactor, otherwise separate supply of the control device required). In case of power controllers from model current 495A, additional signaling is performed via an indicator at the semiconductor fuse.

### 2.4.2 RELAY INDICATIONS K1-K2-K3

The Thyro-P power controller is fitted with three relays. Each of these relays has a change over contact, in principle a value has been allocated in the event register. The default values for parameter settings are listed in chapter 3.5 ERROR ACKNOWLEDGEMENT / DATA LOGGER. The connection terminals are specified in chapter 4 EXTERNAL CONNECTIONS.

#### ALARM RELAY K1

The relay K1 is activated if a fault is detected in the system. The effective direction, whether it should close or open in case of fault, may be set using the parameter Relay ON at message or Relay OFF at message by using LBA-2 or Thyro-Tool Family. Which indications lead to switching of the relay may also be set.

Recommendation: keep the default setting.

### LIMITING RELAY K2

The relay K2 only closes (in default setting) if at least one of the following values is exceeded:

- 1. max. admissible effective value of the load current
- 2. max. admissible effective value of the load voltage
- 3. max. admissible active power of the load

The relay releases if none of the values is exceeded anymore. It is possible to set which indications lead to switching of the relay. Recommendation: keep the default setting.

### OPTIONAL RELAY K3

If changes are made to the default relay settings due to the application, then preferably the relay K3 should be re-parameterized.

It is possible to realize functions like for instance a follow-up relay for ventilator control or by pass the alarm relay at startup of the system. It may also be used as a further alarm relay or limiting relay, by re-parameterization.

The illustration shows the relay K3 for bridging the startup alarm.

## 2.5 MONITORING

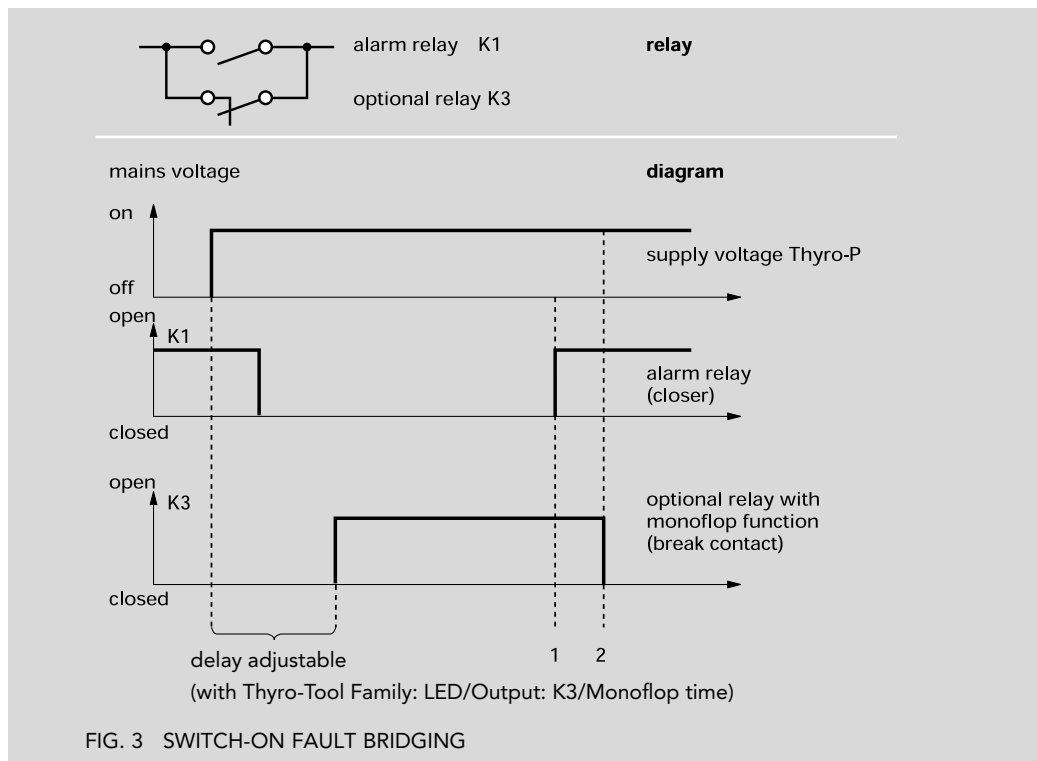

Faults occurring in the power controller or in the load circuit are signaled (s. error messages of LBA-2). Signaling is performed via LED Fault and via relay with potential-free change-over contact. The fault buffer may be read via LBA-2 or the interface after selecting the status line. Simultaneously with the fault signal, the pulse shutdown may optionally also be set (Pulse inhibit On / Off). The number and content of occurred warnings or errors are shown in the status line of LBA-2 touch display. By selecting the status line, the message can be retrieved.

### 2.5.1 MONITORING OF MAINS VOLTAGE

The power controller is equipped with mains voltage monitoring. The limits may be set for U mains min and U mains max. If limits are reached, a status message will be generated.

## 2.5.2. LOAD MONITORING

It is possible to monitor load by absolute monitoring of heating elements with  $R_{hot}/R_{cold} \approx 1$  and relative monitoring of heating elements with  $R_{hot}/R_{cold} \neq 1$ .

### 2.5.2.1 ABSOLUTE VALUE MONITORING CURRENT

This function allows monitoring of a freely selectable absolute current limit. The parameters for the value may be set in ampere.

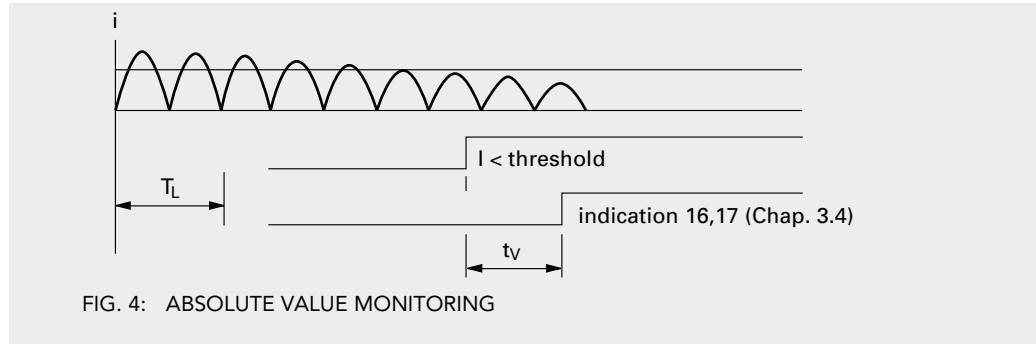

FIG. 4: ABSOLUTE VALUE MONITORING

This absolute value monitoring lends itself to one or more load resistances organized in parallel or in series. Generally, the effective current value measured is continuously compared with a presettable absolute current limit for undercurrent or overcurrent. If these limits are undercut or exceeded an indication occurs after  $T_v = 10$  mains periods. In case of resistor elements organized in parallel, it is therefore possible, using the lower current limit, to detect a partial load interruption. Using the upper current limit, in case of resistors switched in series, short-circuiting of an element may be detected.

### 2.5.2.2 RELATIVE MONITORING

This monitoring is sensible if the resistance value of the load slowly changes. Changes in resistance may for instance be caused by temperature changes or by ageing. The current (b) of the Power Controller is regarded as 100% load current (current in fault-free state) after activation of the RESET or CONTROLLER LOCK. The RESET is automatically activated after each startup, restart or after mains outage. In case of relatively slow changes of the current, due to characteristics of the above mentioned heating elements, automatic adjustment of the internal reference value to 100% is performed (b').

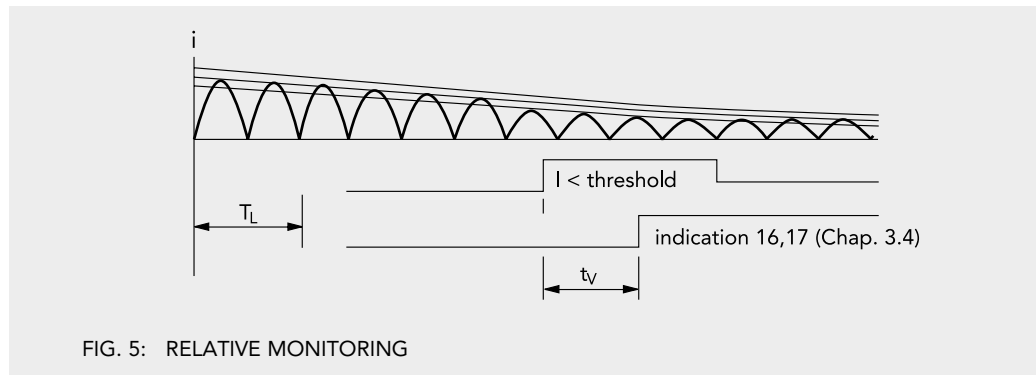

FIG. 5: RELATIVE MONITORING

Quick current changes, which may for instance occur in case of partial short-circuit, may be detected by overcurrent monitoring (max., a – a').

Quick current changes, which may for instance occur in case of load breakdown may be detected by undercurrent monitoring (min., c – c').

**NOTE FOR LOAD MONITORING:**

Load threshold I                    35LSB  
 Load threshold U                    35LSB

If a Thyro-P 3P is used in phase-angle operating mode, the star point of the load and the star point of the (built-in) voltage transformers should be connected together to ensure an accurate load monitoring. Please contact us in case of need..

The values in the following table apply to ohmic loads.  
 Different values apply may be required for specific heating resistors, for instance IR radiators.  
 The adjustable % values shown in the tables are load current variations on the present operating values.

**NOTE**

Values < 10% should be chosen carefully because it can cause wrong error messages, e.g. due to strong fluctuations in mains voltage.

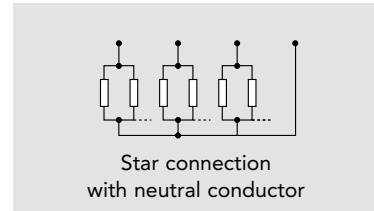
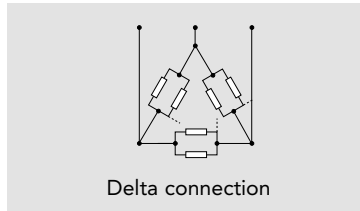
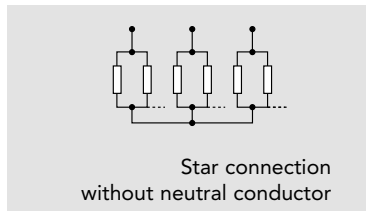
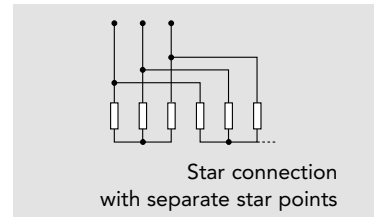

HEATING ELEMENTS IN PARALLEL FOR EACH STRAND	1P		2P*/3P		3P	
	STAR CONNECTION WITH SEPARATE STARPOINTS	STAR CONNECTION WITHOUT CONNECTED NEUTRAL CONDUCTOR	DELTA CONNECTION	STAR CONNECTION WITH CONNECTED NEUTRAL CONDUCTOR		
5	10%	10%	8%	6%	10%	
4	13%	13%	10%	7%	13%	
3	17%	17%	13%	10%	17%	
2	25%	25%	20%	12%	25%	
1	50%	50%	50%	21%	50%	

\* for Thyro-P 2P: additional external converters in phase L2 are possible.

**TAB. 2 PARTIAL LOAD BREAKDOWN WITH HEATING ELEMENTS SWITCHED IN PARALLEL, UNDERCURRENT, RELATIVE MONITORING**

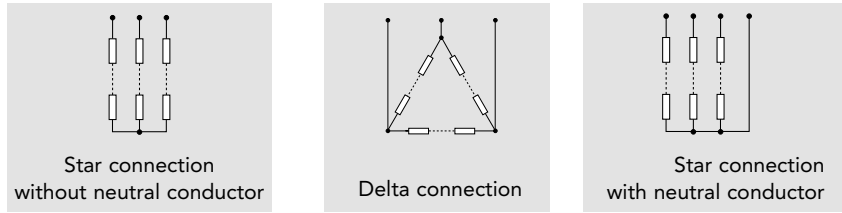

HEATING ELEMENTS IN SERIES FOR EACH STRAND	1P	2P* / 3P		3P
		STAR CONNECTION WITHOUT CONNECTED NEUTRAL CONDUCTOR	DELTA CONNECTION	STAR CONNECTION WITH CONNECTED NEUTRAL CONDUCTOR
6	10%	7%	6%	10%
5	13%	8%	7%	13%
4	17%	10%	9%	17%
3	25%	14%	13%	25%
2	50%	25%	26%	50%

TAB. 3 PARTIAL SHORT-CIRCUIT WITH HEATING ELEMENTS SWITCHED IN SERIES, OVERCURRENT, RELATIVE MONITORING

\* for Thyro-P 2P: additional external converters in phase L2 are possible.

Thyro-P determines the load conductance separately for each phase. These values are available from LBA-2, Thyro-Tool Family and the Bus interface. The current resistance can be determined by reading out and converting from the conductance.

### 2.5.2.3 OVERVIEW MONITORING

The following table offers an overview of the possible monitoring functions of the thyristor power controller Thyro-P.

TYPE OF MONITORING		PARAMETER SETTINGS	DEFAULT / REMARKS
$U_{net\ max}$	mains overvoltage	input in volts	Type voltage + 20%
$U_{net\ min}$	mains undervoltage	input in volts	Type voltage - 20%
$I_{load\ max-REL}$	overcurrent	0-100%	REL_ABS = REL
	overcurrent relative	Re: measured load current after each RESET/control lock	UE_S = ON
$I_{load\ max-ABS}$	overcurrent absolute	input in ampere	REL_ABS = ABS UE_S = ON
	$I_{load\ min-REL}$	undercurrent relative	0 to 99% Re: measured load current after each RESET/control lock
$I_{load\ min-ABS}$		undercurrent absolute	input in ampere
pulse switch off by software	pulse switch off	ON: pulse switch off after fault indication OFF: in case of fault	indication is always issued in case of synchronization SYT 9, RESET of all Power Controllers is required
K1 closed-circuit	alarm relay K1	ON: relay K1 released in case of fault	
		OFF: relay K1 pulled-in in case of fault	the alarm relay switches upon activation of RESET

TAB. 4 OVERVIEW MONITORING

### 2.5.3 FAST CURRENT MONITORING („SHORT CIRCUIT MONITORING“)

Each mains half-wave, the measured actual value of current (per regulated phase) will be compared to an adjustable limit. If limits are exceeded, a status message will be generated. The message is:

$I^2t$  current limit is exceeded

The message can be analyzed by the following parameters:

Fast current monitoring L1	[A]
Fast current monitoring L2	[A]
Fast current monitoring L3	[A]

The messages can be analyzed via relay, LED, data logger, pulse switch off (quit the message).

### 2.5.4 FAN MONITORING

The separately ventilated power controllers (-...HF) are fitted with thermal monitoring. The temperature is measured on the heat sink. In case of a temperature overrange, a fault indication is issued: Unit excess temp.

As a standard the device will be switched off and LED Overheat will be lit.



#### **ATTENTION**

When using the device under UL conditions, this feature has to be switched on.

## 3. OPERATION

This chapter presents the operating options of Thyro-P using local operating and display unit LBA-2 and visualization and commissioning software Thyro-Tool Family.

LBA-2	for Thyro-P parameterization and process data
LBA-2 Tool	for visualization /analysis of saved process data and messages of LBA-2
SEK	for operating of Thyro-P with LBA-2 on cabinet doors
Thyro-Tool Family	for Thyro-P parameterization and process visualization

### 3.1 LOCAL OPERATING AND CONTROL UNIT LBA-2

The new local display and control unit LBA-2 can be used as a substitute for its predecessor LBA model and enables easy operation for Thyro-P thyristor power controllers. The LBA-2 is equipped with a graphic touch display and SD card and is designed to be used either with Bluetooth (model 2.000.000.409) or without Bluetooth (model 2.000.000.408). For both versions the process data recorder feature is included (see chapter 3.1.5 LINE CHART)

With the menu based graphic user interface, LBA-2 offers an intuitive operating of Thyro-P – if requested, further information for configuration and parameterization can be seen in the menu structure table.

If LBA-2 is not in use (parameterized) for a longer duration, the display will dim its brightness.

#### 3.1.1 START SCREEN

The start screen of LBA-2 is its central display which is the first to see after starting LBA-2. It can be switched to:

- Line chart (6 values, optional)
- Operation display (6 values, optional)
- Bar chart (4 values, optional)
- Data logger

The values, which have been selected for the line chart, will be saved as process data on the SD card by LBA-2. They can be analyzed by the free LBA-2 Tool (see chapter 3.2 LBA-2 TOOL).

The four buttons on the start screen have the following functions:



FIG. 6:  
START SCREEN LBA-2



The house symbol will return the user to the start screen from any submenu.



The list symbol will take the user to the main menu of the LBA-2 with further menus to parameterize and to configure

- LBA-2
- Thyro-P



The OFF button operates as a data backup before shutting down LBA-2.

#### NOTE

The LBA-2 must be shut down in order to save all settings and data prior to removing the LBA-2 from the power controller.



By using the logo key, the user can switch between the line chart display, the bar chart display, the operation display and the data logger.

### 3.1.2 SETTINGS LBA-2

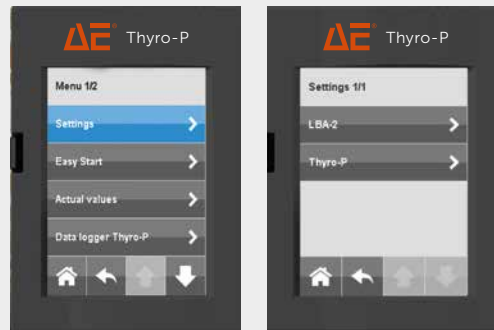

FIG. 7: MAIN MENU LBA-2 (SAMPLE)

To change anything on LBA-2, the button SETTINGS in the main menu has to be pressed. By using the button LBA-2 the following menus will be available:

#### Settings for LBA-2

- Operation display, bar chart, and line chart settings
- Display settings
- Startscreen
- Languages
- Bluetooth
- Authorization and passwords
- Information about the device
- Address
- Reset to factory settings

### 3.1.3 SETTINGS THYRO-P

To change anything on Thyro-P, the button SETTINGS in the main menu has to be pressed. By using the button Thyro-P the following menus will be available:

#### Settings for Thyro-P

- Operating mode
- Control mode
- Control parameters
- Limits
- Analog outputs
- Setpoint inputs
- Relays / LED / pulse inhibit
- Address
- Hardware
- Monitoring
- Temperature
- Data logger Thyro-P

### 3.1.4 EASYSTART

This menu enables the user to easily adjust the Thyro-P. For details on the EasyStart function and its selection possibilities, see table LBA-2 MENU STRUCTURE.

When the user first starts LBA-2, the EasyStart will be displayed. Once the EasyStart prompt has been conducted successfully on LBA-2, it will not appear each time LBA-2 is started. Irrespective of this, EasyStart can be selected at any time if required via the LBA-2 menu.

### 3.1.5 LINE CHART / PROCESS DATA RECORDER

The line chart shows up to 6 values. The chronological process of these values is recorded automatically and saved on the SD card (measuring interval is approx. 1sec.). Therefore a process data recorder is provided to the user with up to 6 channels. The SD card has an amount of memory for max. 6 channels which lasts approx. 2.7 years. Occurring messages (data logger) will also be saved on the SD card and can be analyzed by LBA-2 Tool in combination with the saved signal sequence of the 6 channels. For further details on how to set the line chart, please see table LBA-2 MENU STRUCTURE.

The values selected for the line chart will be saved in the folder SD-Card:\Log. This is the case when

- the date changes (at 0.00 hours)
- the LBA-2 is switched off via OFF button

When the SD card is full, the oldest data will be deleted first and the current data then saved. The data names correspond to the date the process data were measured:

The values selected for the line chart (up to six) will be saved on the 4GB SD card, which is included with delivery under the file named SD-Card:\Log.

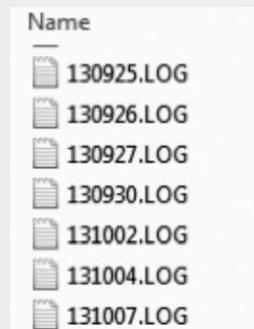

FIG. 8: EXAMPLE ENTRIES LOG FILE

Example of LOG file:

131004.LOG (the process data were measured on October 4th, 2013)



#### NOTE

In the event the LBA-2 is disconnected from the power supply without switching the OFF button (e.g., when switching off the Thyro-P or when "removing „the LBA-2), the measured process data will be lost and will not be saved.

### 3.1.6 LOAD / SAVE DATA

In addition to the process data from the line chart, Thyro-P parameter sets and LBA-2 settings can be stored on the SD card.

The submenus can be found in table LBA-2 MENU STRUCTURE.

Additional parameter sets and configurations can be stored permanently in the EEPROM of the LBA-2.

### 3.1.7 BLUETOOTH

This option is only available with model no 2.000.000.409. It can be switched on and off in the submenu of the LBA-2.

It offers a wireless operation of Thyro-P

- Via Thyro-App\* (by Android smartphone or tablet PC)
- Thyro-Tool Family (e.g. by laptop and Bluetooth)

\*free download from [www.advanced-energy.com](http://www.advanced-energy.com)

As soon as the LBA-2 is connected via Bluetooth using the Thyro-App to a Smartphone or Tablet PC, or to a PC via the Thyro-Tool Family, the display of the LBA-2 shows a Bluetooth symbol and all other functions of the LBA-2 will be automatically deactivated. Therefore operations via display and via Bluetooth are not possible at the same time. Once the Bluetooth connection has ended, the display of the LBA-2 is active again.

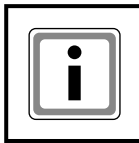

#### NOTE

When using the Bluetooth feature, all other functions are deactivate except the BLUETOOTH ACTIV SYMBOL – this also applies to the PROCESS DATA recorder.

### 3.1.8 PASSWORDS / AUTHORIZATION

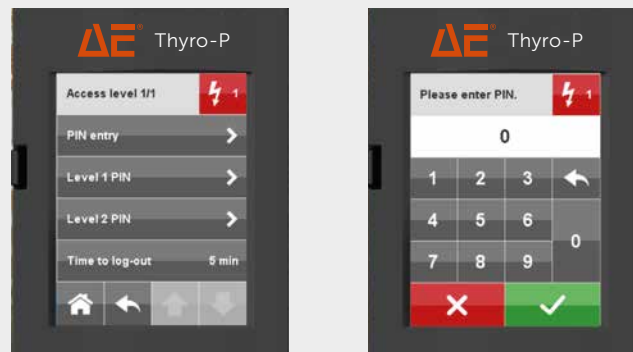

FIG. 9: ACCESS LEVELS

Password Level 1: 160387

Access to parameter settings or EasyStart function

Password Level 2: 311263

Access to detailed parameter settings of the power controller



#### CAUTION

To avoid unauthorized access, change your password settings the first time you use the LBA-2. Only 6-digit numerical password combinations are possible!

### 3.1.9 UPLOAD NEW LBA-2 FIRMWARE

This function enables, if required, current LBA-2 firmware to be uploaded (if available).

The software update can be copied by PC or Notebook on to the SD card of the corresponding LBA-2. Do not open up a new folder on the SD card, but copy the file in the SD card's root directory and if necessary, replace the existing file. As soon as the SD card is inserted in the LBA-2, and the latter is inserted into the active Thyro-P, the firmware update will load automatically. A progress bar will appear that shows the remaining waiting time.

### 3.1.10 LANGUAGES

In the standard version of LBA-2 are the following languages available: German, English, Chinese, French, Swedish, Czech, Turkish and Spanish.

The languages can be selected in the LBA-2 menu, see table LBA-2 MENU STRUCTURE.

On request further languages can be implemented.

## 3.2 LBA-2 TOOL

The LBA-2 Tool (free of charge) offers users to store data on the SD card and to analyze the according process data in combination with data logger entries via PC or Notebook. First the LBA-2 Tool program must be installed on your PC or Notebook. The LBA-2 Tool can be downloaded from the AEI website:

[www.advanced-energy.com](http://www.advanced-energy.com)

All downloaded data have to be copied into a directory. LBA-2 Tool.exe starts up the application.

Then the LOG files, in the folder LOG, can be selected and opened by the LBA-2 Tool. To use the files with LBA-2 Tool, the LOG files can be saved locally on the PC or another medium.

### 3.2.1 OVERVIEW

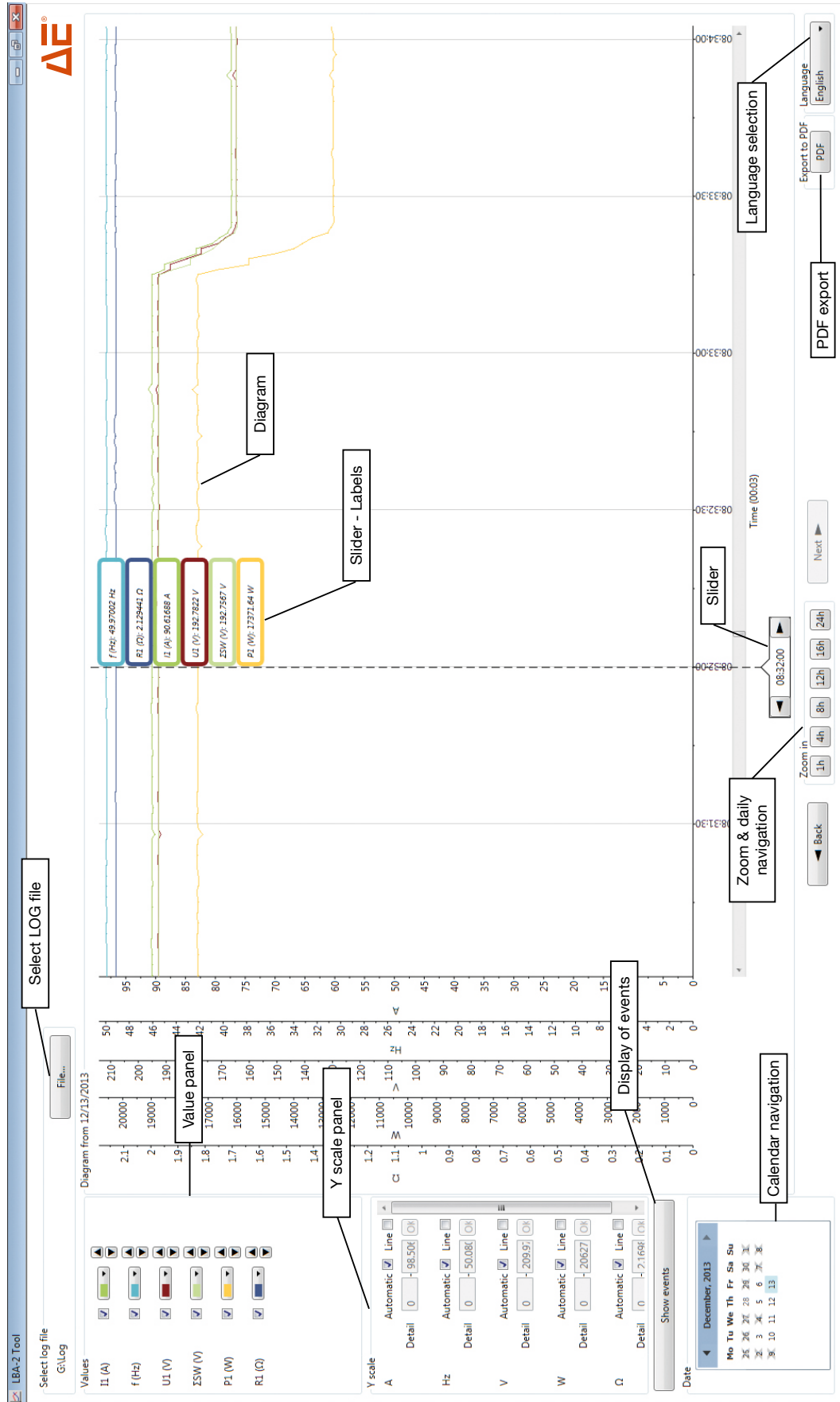

### 3.2.2 LANGUAGES

The languages available in the LBA-2 Tool are German, English, Chinese, French, Swedish, Czech, Turkish and Spanish.

The language selected for the application changes the language during runtime. The language selected will be stored in the user's Windows profile and will be applied again when the program is restarted.

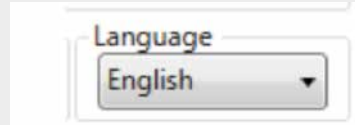

FIG. 10: LANGUAGE SELECTION

### 3.2.3 SELECT LOG FILE FOLDER

A folder with valid log files can be selected via the folder selection. Once the folder is selected, it will be stored in the user's Windows profile and will be applied again when the program is restarted.

Selecting a folder means that the folder will be scanned and all files opened in order to see whether the log files are valid. If there is no read permission for the folder, no data can be located. Data that cannot be opened will be ignored. Data that do not have the required log file identification will be ignored.



FIG. 11: FOLDER SELECTION

### 3.2.4 CALENDAR NAVIGATION

If no valid log files can be found in the selected folder, Calendar navigation will display crossed out date values. If valid log files are located, the valid date values will be visible. Dates between the first and last valid dates, which are invalid will also be crossed out. After selecting a new folder, the last valid log date will be selected.

When clicking onto a valid date, a diagram from that day will be illustrated.

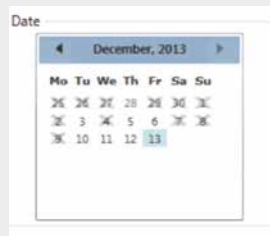

FIG. 12:  
CALENDAR NAVIGATION



FIG. 13:  
CALENDAR NAVIGATION WITH NO LOG FILES  
FOUND

### 3.2.5 TIME AXIS

#### STANDARD ZOOM

Once the program has been turned on, each diagram will be displayed with the 24h zoom setting. This corresponds to the data stored in the log file. By clicking on the other zoom settings, the data view will be reduced accordingly. With the aid of the displayed scrollbar under the diagram, the data view can be shifted horizontally along the time axis.

The buttons Back and Next, next to the standard zoom, direct to the previous or following day of an saved LOG file.



FIG. 14: STANDARD ZOOM KEYS

#### DETAILED ZOOM

By sliding the mouse horizontally on the diagram, a new X axis view can be selected. Thus you can zoom in to a one-minute section. The detailed view that is then displayed can be magnified again only after entering a standard zoom setting.

### 3.2.6 VALUE AXES

With the Y scaling panel, the axes can be changed for the units (up to 6 values) that appear in the diagram. By deactivating the AUTO checkbox, the part of the axis that is automatically calculated can be set by the user. Therefore the displayed area and the resolution of measured signal might be optimized. The horizontal lines for the main section of an axis can be displayed in the diagram by the checkbox line.

The settings for the Y axes will be maintained during navigation.

The modification is relevant for all Y axes having the same unit. Several axes with the same unit can be created, e.g. when two currents are displayed.

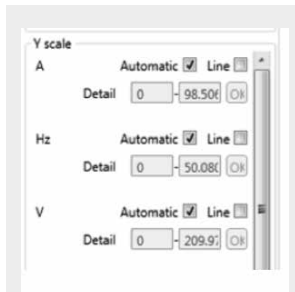

FIG. 15:  
Y SCALING PANEL

The slider can be used to read values on specific points in the diagram. The slider of the time axis (X axis) can be set to any position by using the mouse. By clicking with the left side of mouse directly on the slider, it can be moved to another position. When the slider is released, the slider labels show the values of line chart (color like selected in the relating line chart) and their according units. With both buttons the slider can be moved either one second to the right or left. Is the slider on the leftmost or rightmost of the diagram (parking position), then no labels are be shown.

While zooming, the slider maintains its position on the X axis. If, however, the slider is located at a position on the X axis, which is not a part of the zoomed section, then it will be put into parking position on the left or right depending on where it was previously located.

### 3.2.7 VALUES DISPLAY

The values display panel can change the appearance of the diagram with regard to the value sequences. By deactivating the checkboxes, the value sequences can be switched off and with the help of color settings, the color of the values sequences (bar chart) can be changed.



FIG. 16:  
VALUE PANEL

By pressing the UP and DOWN buttons, the value times series can be displayed as a diagram in an active drawing layer above or below the other times series.



During navigation the settings for the times series will not be deleted.

### 3.2.8 EVENT REPORTS

Messages can be seen in combination with line chart data when recorded during Thyro-P operation.

By clicking on the SHOW EVENTS button, the event panel will be displayed. If an error, a warning, or information event is selected on this panel, it will appear in the diagram as a colored area. The slider will return to the start of the Event.

If the event does not lie within the zoomed section, the displayed section will be moved accordingly.

Only one event will be displayed at a time in the diagram. If the event panel is closed, the currently displayed event will also be closed.

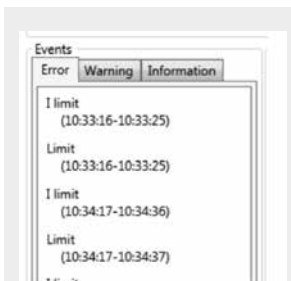

FIG. 17:  
EVENT PANEL DETAILS

### 3.2.9 PDF EXPORT

By clicking on the EXPORT TO PDF button, the current-status diagram, together with a legend of the time series, will be saved in a PDF file.

### 3.2.10 EXAMPLE

#### TASK

For all production days in September 2013 process data have to be checked for thyristor current supply of the 10.00 o'clock change of charges.

#### STEP BY STEP SOLUTION

1. Select the first day of production of the month (13.11.2013) in the calendar.
  2. Press the Standard-Zoom-Button 24h to show the whole day.
  3. Draw up Detail-Zoom frame  
(by using the left side of mouse from approx. 9:45 a.m. to 10:15 a.m.)
  4. Check the curve progression
  5. By using the NEXT button (right hand side to standard zoom button) the data set of the next recording day (17.11.2013) can be seen
- Repeat 4 and 5 until all production days have been checked. If necessary a PDF can be created.



FIG. 18:  
EXAMPLE CALENDAR

### 3.3 CABINET INSTALLATION KIT (SEK)

The cabinet installation kit (optional: model 2.000.000.405) enables the LBA-2 to be mounted on a cabinet door with a thickness of up to 4mm. It consists of one 96x72mm adapter frame (cut-out dimensions 92x68mm) and a cable. The LBA-2 is connected to the RS232 interface of the Thyro-P via the cable. The LBA-2 clicks into the adapter frame and can only be removed when the cabinet door is open. In this way the technician can set the parameters (e.g. adjustments to retooling) and manual setpoint setting (motor potentiometer) as well as reading of the actual values without opening the door. The SEK offers an operation of Thyro-P with closed cabinet doors.

If the LBA-2 is connected to the power controller via a long cable and cannot be operated, it can be provided by increase of supply voltage (by opening the R155 wire jumper in the control unit).



#### WARNING

When the R155 wire jumper is open, the LBA-2 should not be connected to the power controller without cables (risk of damage). The position of the wire jumper can be seen on the layout diagram of circuit board of the control unit (see chapter 4).

### 3.4 THYRO-TOOL FAMILY

Thyro-Tool Family is optional software for commissioning and visualization under Windows 95/98/NT 4.0/XP and higher. It includes all functions of Thyro-Tool P and it is connected to Thyro-P via RS232 interface.

Thyro-Tool Family may be employed as an alternative to LBA-2 and as already stated above has the following functions, for which several windows may be opened simultaneously:

- set point and actual value processing with overview display for 22 set point/actual value input options for motor potentiometer and total set points.
- loading, storing, modification and printing of parameters
- comparison of parameters

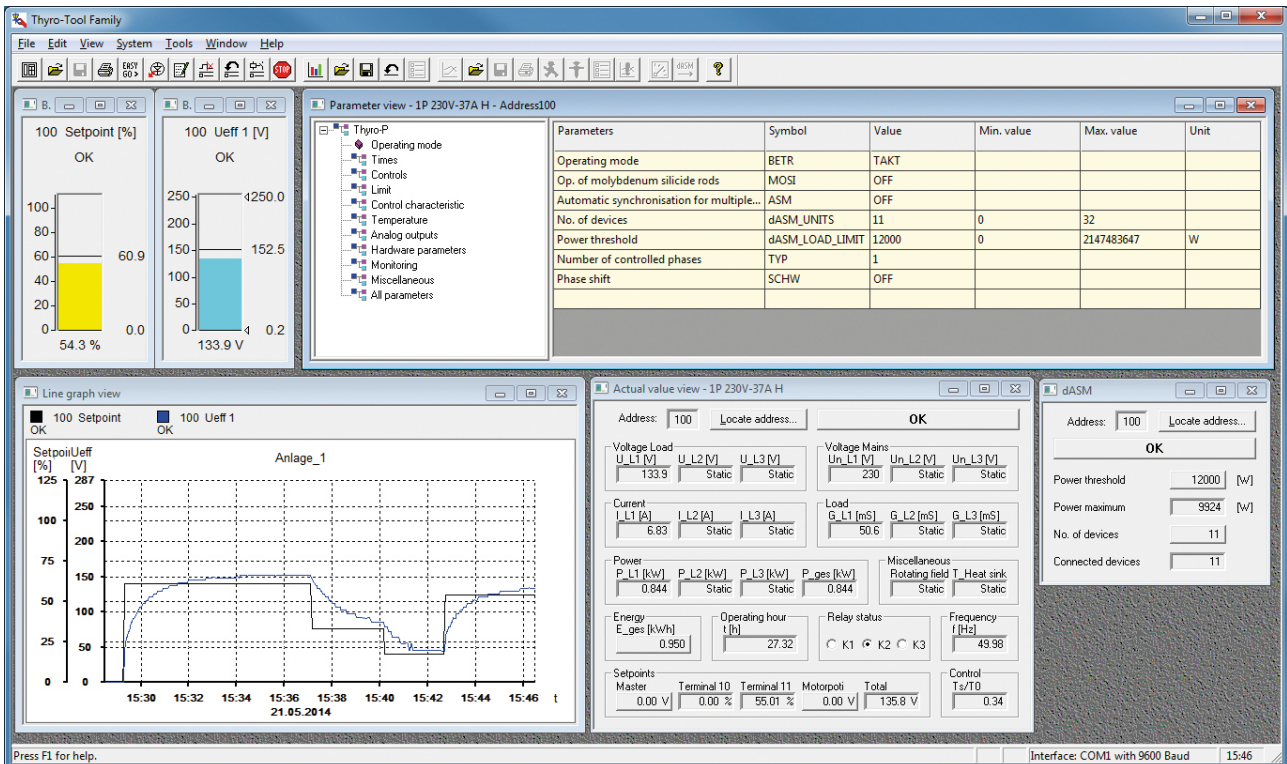

FIG. 19: EXAMPLE FOR USER INTERFACE THYRO-TOOL FAMILY

It is possible to compare two sets of parameters (power controller or data file). It is thus possible, to detect deviations from the desired configuration.

- line diagrams of process data with printing function, as well as storage of faults (diverse measured values from different thyristor power controllers may be displayed simultaneously).
- bar diagram display

It is possible to simultaneously display several bar diagrams. Each diagram has its own window. These can be adjusted in size and location. The configuration of the display may be stored.

- simultaneous display of data and parameters from several power controllers
- simultaneous connection of up to 998 Thyro-P power controllers using fiber optic distributors
- settings of the interface (baud rate, com...)

### 3.5 ERROR ACKNOWLEDGEMENT / DATA LOGGER

Unexpected operation of Thyro-P can be diagnosed by

- LEDs on the front panel of the control device
- comparing parameters with Thyro-Tool Family (where the changed parameters can be listed)
- reading out the error memory of the Thyro-P (data logger) with LBA-2 or Thyro-Tool Family

Errors and messages that occur will be recorded in the status register of the Thyro-P data logger at the time they occur and will not be lost even after a power failure. Up to 16 entries are possible and are displayed by LBA-2. If there are further entries, the initial ones will be overwritten, i.e., the 16 most up-to-date events will be accessible.

LBA-2: Data logs

dd.mm.yyyy hh:mm:ss

[Abbreviated error description]

The entries in the data logger are also available after power failure.



### 3.5.1 LBA-2

#### DISPLAY OF ERROR MESSAGES

If there are status messages, a red or yellow reference will appear in the LBA-2 status line (see illustration).

Yellow:	Status messages / Warnings
Red:	Error messages Incl. further status messages

By pressing the status field, individual events can be displayed on the LBA-2 in the data logger view. Then previous events can also be seen. Occurring messages, which are recorded by the data logger, are also secured just like the process data of line chart and are therefore documented. The number of saved messages is nearly unlimited which can be used for analyzing purposes. The data logger can also be set up as start screen.

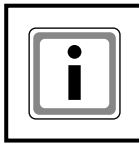

#### NOTE

If the SD card is removed for analyzing purposes, it is required to shut down the LBA-2 by using the OFF button.

#### ACKNOWLEDGE ERROR MESSAGES

Error messages and warning can be reset in the LBA-2 menu (page 2/2: ACKNOWLEDGE ERRORS).

#### ACTIVATE MESSAGES FOR DATA LOGGER

To activate messages in Thyro-P data logger, they have to be parameterized. This has to done by the LBA-2 menu:

After selecting menu SETTINGS / THYRO-P (page 3/3) / DATA LOGGER, the messages are shown in order and can be selected.

### 3.5.2 THYRO-TOOL FAMILY

Using the Thyro-Tool Family and active line chart, errors and messages that occur will be displayed in a window and stored on the hard drive as per the line chart. Via a bus interface option (e.g., Profibus DPV1, Profinet, Modbus TCP, EthernetIP, Modbus RTU, DeviceNet), a message will be communicated automatically. As already mentioned, the status messages generated from the Thyro-P (errors, warnings, messages) refer either to the load or the power controller in the Thyro-Tool Family. Depending on the application, either warnings or status messages will be displayed.

As a deviation from the default factory setting, all messages can be switched on the data logger, on the relays and on the LEDs. The default factory settings are as follows:

X = Default settings	Data logger	K1	K2	K3	LED Control Lock	LED Limit	LED Pulse Lock	LED Fault	LED Overheat	Pulse inhibit	Reset trigger	Bus	Thyro-Tool Family	LBA-2	Comments
RS232 interface active												-	-	X	
Optical fiber interface active												-	-	X	
Negative power												-	X	X	Test external converter on correct connection
Communication error												-	X	X	RS232 or fibre optic interfaces, dyn. Messages
No extension												-	-	X	No bus card available (message after approx. 10sec)
External error message												-	X	X	External message to forward, e.g. to relay
After reset												-	-	X	Mains failure detection of control device supply
Controller inhibit							X					X	X	X	Controller inhibit is active
Invalid data in EEPROM												-	X	X	All parameters are useless (factory and customer parameter)
Limit			X			X						X	X	X	dyn., non regulated values are at limit
Unit excess temp.	X								X	X		X	X	X	
Fast current shut-off												-	X	X	Peak value message U, I
Incorrect no. of dASM devices												-	X	X	
Undercurrent in load circuit												X	X	X	Load monitoring: Undercurrent message
Overcurrent in load circuit												X	X	X	Load monitoring: Overcurrent message
i2t current limit is exceeded												-	X	X	
Mains OK	X											-	-	X	Mains failure detection for MOPO feature
Undervoltage at mains input												X	X	X	Mains voltage monitoring L1 / L2 / L3
Overvoltage at mains input												X	X	X	Mains voltage monitoring L1 / L2 / L3
SYNC error		X						X				X	X	X	Synchronization error e.g. by soft mains or wiring error
dASM power threshold is exceeded												-	X	X	
MOSI: Peak current limit												X	X	X	
Temperature sensor Sensor breakage / short circuit	X								X	X		X	X	X	

TAB. 5 ERROR AND DATA LOGGER MESSAGES

## 3.6 LBA-2 MENU STRUCTURE

Menu	Submenu	Access level	Default value	Remarks
Settings				
LBA-2				
Operation display				Max. 6 channels available; ON / OFF per channel, choosing variable
Bar chart				Max. 4 channels available; ON / OFF per channel, choosing variable and color
Line chart				Max. 6 channels available; ON / OFF per channel, choosing variable and color
Display				
	Operating brightness Brightness after standby Time until standby  Calibrating display			Display brightness during active usage Display brightness of standby mode Selection of duration till when the brightness will turn down to the value set above; constant level of brightness by setting 0
Start screen				
	Operation display Bar chart Line chart Data logger Thyro-P Time until activation		X	Data shown as numerical values on the display Data shown as bar chart on the display Data shown as line chart on the display  Selection of duration till when the start screen will appear automatically; No automatically setting back to start screen by setting 0
Language				
	Deutsch English Français Čeština Español Türkçe Italiano 中文 Svenska		X	German English French Czech Spanish Turkish Italian Chinese Swedish
Bluetooth				
				Turn on / off Bluetooth feature (only type 2.000.000.409) Shows demanded PIN, device name and address
Access levels				
	PIN entry Level 1 PIN Level 2 PIN Time to log-out		X-2 X-2 X-2	Enabling of password functions Enabling of additional settings Changing level 1 PIN Changing level 2 PIN Setting period of validity
Information				
Address				
Reset to factory settings				
Thyro-P				
Operating mode				
	TAKT		X-1	
	1st phase angle		X-1	60°el for Thyro-P 1P, otherwise 90°el., default value for transformers
	Softstart		X-1	0.3 0 to (T <sub>0</sub> -20ms), default value 300ms, ramp time up
	Softdown		X-1	0.3 0 to (T <sub>0</sub> -20ms), default value 300ms, ramp time down
	TAKT cycle period T <sub>0</sub>		X-1	1.000 Display / default of TAKT cycle period T <sub>0</sub>
	Turn on-time T <sub>s</sub> max		X-1	Display of on-time T <sub>s</sub>
	Turn on-time T <sub>s</sub> min		X-1	Display of on-time T <sub>s</sub>
	Synchronal delay		X-1	Turn on-time delay at resumption of power supply
	MOSI		X-1	RAMP or STELL; Rate of angular displacement 1 and 2 (Access level 2)
	Min. break ASM		X-1	60ms Depends on transformer Display of ASM process; Setting time constant, waiting period, threshold, tolerance
	dASM		X-1	Display of dASM process; Setting of no. of devices and power threshold
	VAR			
	Softstart		X-1	0.3 0 to (T <sub>0</sub> -20ms), default value 300ms, ramp time up
	Softdown		X-1	0.3 0 to (T <sub>0</sub> -20ms), default value 300ms, ramp time down
	MOSI		X-1	RAMP or STELL; Rate of angular displacement 1 and 2 (Access level 2)
	Front pulse limit position Back pulse limit position		X-1 X-1	
	SSSD			
	Softstart		X-1	0.3 0 to (T <sub>0</sub> -20ms), default value 300ms, ramp time up
	Softdown		X-1	0.3 0 to (T <sub>0</sub> -20ms), default value 300ms, ramp time down

		TAKT cycle period T <sub>0</sub>	X-1	1.000	Display / default of TAKT cycle period T <sub>0</sub>
		Turn on-time T <sub>s</sub> max	X-1		Display of on-time T <sub>s</sub>
		Turn on-time T <sub>s</sub> min	X-1		Display of on-time T <sub>s</sub>
		Synchronous delay ASM	X-1		Turn on-time delay at resumption of power supply
		dASM	X-1		Display of ASM process; Setting time constant, waiting period, threshold, tolerance
	VSC_VAR				Display of dASM process; Setting of no. of devices and power threshold
		No. of stages	X-1		<b>NOTE:</b> The wiring of Thyro-P has to be changed!
		VSC overlapping	X-1		
		External measurement	X-1		
Control mode					Parameterization of control characteristics
	I		X-1		
	I <sup>2</sup>		X-1		
	U		X-1		
	U <sup>2</sup>		X-1	X	
	P		X-1		
	No control		X-1		
Control parameters					Select between standard controller and controller (configurable)
	Standard controller				Display of P part (numerator / denominator), I part and D part
		Standard Limit			
	Controller		X-1		Setting controller parameters
		Standard	X-1		Display of P part (numerator / denominator), I part and D part
		P part (numerator)	X-1	Type	
		P part (denominator)	X-1	Type	
		I part	X-1	Type	
		D part	X-1	Type	
		Limit	X-1	Type	Display of P part (numerator / denominator), I part and D part
		P part (numerator)	X-1	Type	
		P part (denominator)	X-1	Type	
		I part	X-1	Type	
		D part	X-1	Type	
Limits					Setting limit values
	U max		X-1	Type	Display / settings (Phase voltage as factory setting for Thyro-P 3P)
	I max		X-1	Type	Display / settings
	P max		X-1	Type	Display / settings
	U min		X-2	0	
	I min		X-2	0	
	P min		X-2	0	
	Offset		X-2		
Analog outputs					
	Analog output 1				
		Value	X-1	U1	Selection of (depends on power controller type): U1, U2, U3, U total, I1, I2, I3, I total, P1, P2, P3, P total, alpha, Total set point, U min, I min, P min, U max, I max, P max, Ts/T0
		Full scale value mA / V - switchover	X-1	V	Depends on selection above; in V, A or kW
		Max. value analog output	X-1	10 V / 20 mA	Switchover between 10 V or 20 mA Setting max. analog output value; Depending on selection in V or mA
	Analog output 2				
		Value	X-1	I1	Selection of (depends on power controller type): U1, U2, U3, U total, I1, I2, I3, I total, P1, P2, P3, P total, alpha, Total set point, U min, I min, P min, U max, I max, P max, Ts/T0
		Full scale value mA / V - switchover	X-1	A	Depends on selection above; in V, A or kW
		Max. value analog output	X-1	10 V / 20 mA	Switchover between 10 V or 20 mA Setting max. analog output value; Depending on selection in V or mA
	Analog output 3				
		Value	X-1	P1	Selection of (depends on power controller type): U1, U2, U3, U total, I1, I2, I3, I total, P1, P2, P3, P total, alpha, Total set point, U min, I min, P min, U max, I max, P max, Ts/T0
		Full scale value mA / V - switchover	X-1	kW	Depends on selection above; in V, A or kW
		Max. value analog output	X-1	10 V / 20 mA	Switchover between 10 V or 20 mA Setting max. analog output value; Depending on selection in V or mA
	Average				
Setpoint inputs					
	Motor potentiometer		X-1		Setting setpoint 4

Setpoint 1 (terminal 10) Setpoint 2 (terminal 11) Master (Bus) Total		X-1		Display setpoint 1 Display setpoint 2 Setting setpoint 3 Display total setpoint
Settings of setpoint inputs		X-1		
	Setpoint 4 mopo	X-1		
	Setpoint 1 analog (10)	X-1		
	Signal type	X-1		Selection between 0...5 V, 0...10 V and 0...20 mA <b>NOTE:</b> For signal range 0...5 V / 0...10 V: Please open jumper X221. For signal range 0...20 mA: Please close jumper X221.
	Control start	X-1	0,3 mA	
	Control end	X-1	20,0 mA	
	Setpoint 2 analog (11)	X-1		
	Signal type	X-1		Selection between 0...5 V, 0...10 V and 0...20 mA <b>NOTE:</b> For signal range 0...5 V / 0...10 V: Please open jumper X221. For signal range 0...20 mA: Please close jumper X221.
	Control start	X-1	0,7 V	
	Control end	X-1	5,0 V	
	Setpoint 3 remote	X-1		
Setpoint link		X-1		Selection between Addition (SW1+SW2), Subtraction (SW1-SW2), Multiplication (SW1*SW2%/100%), Inverse Multiplication (SW1*(1-SW2%/100%))
Relay / LED / pulse inhibit				
	K1		X-1	
	Select event *	X-1		See chapter Error acknowledgement / Daten logger
	Mode	X-1		Selection between switch, static, Monoflop, blink, alpha PWM, switch delayed, cyclic Monoflop, static inverse
	Error acknowledge of controller inhibit	X-1		On / Off of error acknowledge with controller inhibit
	Error acknowledge of input X5.2.19	X-1		On / Off of error acknowledge with input X5.2.19
	Delay time	X-1		Selection of 1s, 2s, 3s, 4s, 5s, 6s, 7s, 8s, 1min, 2min, 3min, 4min, 5min, 6min, 7min, 8min
	Functionality	X-1		Setting relay On or Off at message
	K2		X-1	
	Select event *	X-1		See chapter Error acknowledgement / Daten logger
	Mode	X-1		Selection between switch, static, Monoflop, blink, alpha PWM, switch delayed, cyclic Monoflop, static inverse
	Delay time	X-1		Selection of 1s, 2s, 3s, 4s, 5s, 6s, 7s, 8s, 1min, 2min, 3min, 4min, 5min, 6min, 7min, 8min
	Functionality	X-1		Setting relay On or Off at message
	K3		X-1	
	Select event *	X-1		See chapter Error acknowledgement / Daten logger
	Mode	X-1		Selection between switch, static, Monoflop, blink, alpha PWM, switch delayed, cyclic Monoflop, static inverse
	Error acknowledge of controller inhibit	X-1		On / Off of error acknowledge with controller inhibit
	Error acknowledge of input X5.2.19	X-1		On / Off of error acknowledge with input X5.2.19
	Delay time	X-1		Selection of 1s, 2s, 3s, 4s, 5s, 6s, 7s, 8s, 1min, 2min, 3min, 4min, 5min, 6min, 7min, 8min
	Functionality	X-1		Setting relay On or Off at message
	LED Control		X-1	
	Select event *	X-1		See chapter Error acknowledgement / Daten logger
	Mode	X-1		Selection between switch, static, Monoflop, blink, alpha PWM, switch delayed, cyclic Monoflop, static inverse
	Delay time	X-1		Selection of 1s, 2s, 3s, 4s, 5s, 6s, 7s, 8s, 1min, 2min, 3min, 4min, 5min, 6min, 7min, 8min
	Functionality	X-1		Setting relay ON or OFF at message
	LED Limit		X-1	
	Select event *	X-1		See chapter 12. Error acknowledgement / Daten logger
	Mode	X-1		Selection between switch, static, Monoflop, blink, alpha PWM, switch delayed, cyclic Monoflop, static inverse
	Delay time	X-1		Selection of 1s, 2s, 3s, 4s, 5s, 6s, 7s, 8s, 1min, 2min, 3min, 4min, 5min, 6min, 7min, 8min

		Functionality	X-1		Setting relay On or Off at message
	LED Pulse Lock		X-1		
		Select event * Mode	X-1 X-1		See chapter Error acknowledgement / Daten logger Selection between switch, static, Monoflop, blink, alpha PWM, switch delayed, cyclic Monoflop, static inverse
		Delay time	X-1		Selection of 1s, 2s, 3s, 4s, 5s, 6s, 7s, 8s, 1min, 2min, 3min, 4min, 5min, 6min, 7min, 8min
		Functionality	X-1		Setting relay On or Off at message
	LED Fault		X-1		
		Select event * Mode	X-1 X-1		See chapter Error acknowledgement / Daten logger Selection between switch, static, Monoflop, blink, alpha PWM, switch delayed, cyclic Monoflop, static inverse
		Error acknowledge of controller inhibit	X-1		On / Off of error acknowledge with controller inhibit
		Error acknowledge of input X5.2.19	X-1		On / Off of error acknowledge with input X5.2.19
		Delay time	X-1		Selection of 1s, 2s, 3s, 4s, 5s, 6s, 7s, 8s, 1min, 2min, 3min, 4min, 5min, 6min, 7min, 8min
		Functionality	X-1		Setting relay On or Off at message
	LED Overheat		X-1		
		Select event * Mode	X-1 X-1		See chapter Error acknowledgement / Daten logger Selection between switch, static, Monoflop, blink, alpha PWM, switch delayed, cyclic Monoflop, static inverse
		Error acknowledge of controller inhibit	X-1		On / Off of error acknowledge with controller inhibit
		Error acknowledge of input X5.2.19	X-1		On / Off of error acknowledge with input X5.2.19
		Delay time	X-1		Selection of 1s, 2s, 3s, 4s, 5s, 6s, 7s, 8s, 1min, 2min, 3min, 4min, 5min, 6min, 7min, 8min
		Functionality	X-1		Setting relay On or Off at message
	Pulse inhibit		X-1		Select message *
	Reset trigger		X-1		Select message *
Address			X-2		
	Bus + Optical fiber		X-2	100	Optical fiber 001 - 998; Profibus DPV1 001 - 125; Modbus RTU 001-247; DeviceNet 001-063; 000 and 999 have special features
Hardware					
	Average Current transformer ratio		X-2	100	Ratio $\bar{u}$ :1
	Voltage transformer ratio		X-2	16	Ratio $\bar{u}$ :1
	Voltage range		X-2		Selection between 230 V, 400 V, 500 - 690 V <b>NOTE:</b> Please set jumper X501 according to the configuration.
	Rated current		X-2	Type	Depends on type
	Rated voltage		X-2	Type	Settings of load resistor incl. tolerances
	Rated power		X-2	1 Ohm	Setting and display
	U_Load resistor		X-2	1 Ohm	Setting and display
	Date		X-1		Setting and display
	Time		X-1		Setting and display
	Peak current		X-2	65000 A	Peak current value at which the pulse inhibit should be set immediately
	Measuring circuit		X-2		Selection between Aron, half Aron 1, half Aron 2, half Aron 3, asym. load, sym. Load
	Frequency		X-2		Setting and display of min. / max. frequency and tolerance
	No. of controlled phases		X-1	1	Number of controlled phases (power paths)
	Neutral conductor		X-2	OFF	Turing feature On or Off; Only for 3 phases
	Phase shift		X-2	0	Phase shift for L1, L2, L3, selection between negative (-) and positive (+)
	Service		X-AEI	OFF	Operation without controls and limits
	Re-ignitions		X-2	ON	Turing feature On or Off; Only for 3 phases and VAR
	Duration of re-ignitions		X-2		
	Channel separation		X-2		Turing feature On or Off
	Number of SYNC voltages		X-2		Selection 1-3
	SYNC rotating field		X-2		Selection between right or left rotating field
Monitoring					
	Mains voltage				
		Min. mains voltage monitoring	X-1		
		Max. mains voltage monitoring	X-1		
	Load				Display / setting of monitoring values
		Monitoring type	X-1		Selection between Relative (in %) or Absolute (in A)
		Undercurrent monitoring	X-1	OFF	Turing feature On or Off

		Overcurrent monitoring	X-1	OFF	Tuning feature On or Off
		Min. load break	X-1	0	Depending on selection above in % or A; Prior activation of undercurrent monitoring
		Max. load break	X-1	0	Depending on selection above in % or A; Prior activation of overcurrent monitoring
		Monitoring L2 Enable	X-2	OFF	
		Monitoring L3 Enable	X-2	OFF	
		i <sup>2</sup> t fast current monitoring	X-2		Setting of fast current monitoring for L1, L2 and L3
Temperature			X-2		Details only turn up when a temperature controller (PT100, PT1000 or NTC) is selected
	PT100		X-2		Used temperature sensor
		Characteristic no.	X-2	Type	Depends on type
		Level wire breakage	X-2		
		Level sensor short circuit	X-2		
	PT1000		X-2		Used temperature sensor
		Characteristic no.	X-2	Type	Depends on type
		Level wire breakage	X-2		
		Level sensor short circuit	X-2		
	NTC		X-2		Used temperature sensor
		Characteristic no.	X-2	Type	Depends on type
		Level wire breakage	X-2		
		Level sensor short circuit	X-2		
Data logger Thyro-P			X-1		Select message *
EasyStart			X-1		Please confirm the request to start EasyStart configuration
Operating mode					Selection between TAKT, VAR or SSSD
Load type					Selection between R-Last and RL-Last
Dynamic					Selection between Slow (T0=1s) and Fast (T0=0,1S)
Control mode					Selection between U <sup>2</sup> . U. I <sup>2</sup> . I. P or Off
Control end value					Default depends on Thyro-P type
Conclusion					Display of above selection; When confirming the selection, the previously selected parameters will be implemented immediately into Thyro-P
Actual values					Display of Thyro-P actual values
Data logger Thyro-P					Current display of data logger entries
Line chart					Display of line chart in historical course; Turning On and Off of channels and settings of values displayed
Load / save data					
Load LBA-2 configuration to SD card					Load line charts or LBA-2 configuration which have been saved on SD card
Save LBA-2 configuration from SD card					Save LBA-2 settings and line charts on SD card
Save Thyro-P parameters from SD card					Save a copy of Thyro-P parameterization on SD card
Load Thyro-P parameters from SD card					Load parameterization to Thyro-P which has been saved on SD card
Save Thyro-P parameters to EEPROM					Permanently save Thyro-P parameterization from RAM to EEPROM
Acknowledge errors					Acknowledge of errors and warnings

X-1 Password level 1  
X-2 Password level 2  
X-AEI AEI password protected parameter

TAB. 6 LBA-2 MENU STRUCTURE

## 4. EXTERNAL CONNECTIONS

This chapter describes external connections of Thyro-P as well as all available terminal strips and signals as necessary. The connections of the interfaces

- X10 RS232 (optional with Bluetooth adapter or LBA-2)
- X30 Fiber optic receiver
- X31 Fiber optic sender
- X20 Bus interfaces
- X40 dASM input
- X41 dASM output

are described in chapter 5.

Shielded cables grounded on Thyro-P must be used for the connections of control signals (set point inputs and analogue outputs).

For the connections to RESET, controller inhibit and QUIT, twisted cables must be used.

Bus interfaces can be found in chapter 5 INTERFACES.

To operate Thyro-P at least the following signals described up to chapter 4.6 QUIT must be connected.

### 4.1 POWER SUPPLY FOR THYRO-P

Details on connecting power supply can be taken from the chapters TECHNICAL DATA and CONNECTING DIAGRAMS. This particularly applies when using the control device in UL applications.

### 4.2 POWER SUPPLY FOR THE CONTROL DEVICE A70

The Thyristor Power Controller Thyro-P is fitted with a wide-band power supply. The mains connection is designed for input voltages from 230V -20% to 500V +10% and nominal frequencies from 45Hz to 65Hz. The power consumption is max. 30W. Depending on the switch mode power supply, a 100VA control transformer must be used.

For the type ranges 400V (230-400V) and 500V nominal mains voltage, the control device is supplied directly from the power section. It is therefore a unit ready to connect.

If the power controller is connected to the power supply, for types ranges 230-400V and 500V the control unit of Thyro-P is therefore already connected to current supply. 1- and 2-phase Thyro-P units need on A1-X1.3 an additional wiring in accordance to the connecting diagram (chapter 8). The control device of 690V types has to be feed separately.

#### TERMINAL STRIP X1

X1	mains supply connected internally
1	phase
2	N or phase

TAB. 7 TERMINAL STRIP X1



#### REMARK

If required, e.g. when operating with Profibus, the control device can also be supplied separately. With supply voltages outside the nominal range the control device must be supplied separately with an input voltage within the above-mentioned voltage range. The phase position of this control voltage is optional. In this case the plug (A70/X1) must be pulled.

**CAUTION**

The pulled plug has mains voltage of the load circuit! The new connecting lines must be fused according to the applicable regulations (for applicable plug, see chapter 13).

**4.3 POWER SUPPLY FOR THE VENTILATOR**

With Thyro-P Thyristor Power Controllers furnished with integrated ventilators (HF types), the ventilator must be supplied with a voltage of 230V 50/60Hz according to the connecting plans and the dimensional drawings. The ventilator's power consumption is given in chapter 11 TECHNICAL DATA.

**ATTENTION**

The ventilator must run when the Power Controller is switched on.

**4.4 RESET**

The input RESET (terminals X5.2.12-X5.1.14) is separated from the remaining system by an optoelectronic coupler. By opening the RESET jumper the Thyristor Power Controller is locked (load: 24V/20mA), i.e. the power sections are no longer triggered. On activating RESET, LED "ON" lights up red.

Functional procedure:

TERMINALS	FUNCTION
X5.12-14 closed	Enables the device
X5.12-14 open	Device is out of operation, communication via interfaces not possible

TAB. 8 RESET

The hardware RESET must be applied when synchronizing the software of several Power Controllers (chapter 6.3 SOFTWARE SYNCHRONIZATION). If the Power Controller is equipped with a Bus option, a Bus RESET also ensues from the hardware RESET. Apart from opening the jumper terminal X5.2.12-X5.1.14, the hardware RESET is also activated by supply voltage OFF or by reducing the supply voltage at the Power Controller (A70-X1) to below 160V.

**4.5 CONTROLLER INHIBIT**

The input controller lock (terminals X5.2.15 and X5.1.14) is electrically identical to the input RESET (electrical data as under 4.4.).

**ATTENTION**

When activating controller lock, the LED „PULSE LOCK“ is lit and the control device remains completely in operation. The total set point is therefore without effect, but the min. limiting values (TS-MIN, HIME) remain active. This enables securing a certain quantity of electrical energy at the load.

TERMINALS	FUNCTION
X5.15-14 closed	power controller operating
X5.15-14 open	control pulses OFF (default value) or pulse limit

TAB. 9 CONTROLLER LOCK

All other functions of the power controller remain in operation. The state of the signalling relay does not change (parameter-dependent) and communications remains active. After closing the controller lock jumper, the controller is back in operation.

**4.6 QUIT**

The input acknowledge (Quit, X5.2.19) has a circuit identical with the input RESET. It must be

short-circuited against ground (X5.1.14) so that any faults are acknowledged. The fault signalling relay is reset. The input must remain closed for at least 2 line periods to perform acknowledgement. After acknowledgement, the contactor must in turn be opened.

Function:

TERMINALS	FUNCTION
X5.19-14 open	controller operating
X5.19-14 closed*	faults are reset
* for at least 2 line periods	

TAB. 10 QUIT

If the QUIT contact is reopened the Controller will reassume operation with its preset operating and control modes as well as its set point and limiting values.

#### 4.7 SET POINT VALUE INPUTS

The set point inputs are described in chapter 2.2. SET POINT CONTROL CHARACTERISTIC.

#### 4.8 ASM INPUT

This input (analogue voltage signal) is for measuring the total current signal of the external resistance. For further details see chapter 6.4 ASM PROCEDURE.

#### 4.9 dASM INPUT - dASM OUTPUT

The connections dASM input (X40) and dASM output (X41) are located at the bottom of Thyro-P control device and have to be wired only if dASM function is used.

The wiring has to be done with patch cables (Ethernet CAT 5 8-pole) and only for a length of up to 100m between 2 power controllers.

#### 4.10 ANALOG OUTPUTS

The electrical values for current, voltage and power at the load as well as the set point are recorded by the Power Controller Thyro-P and may be optionally displayed using an external instrument or logged using a graph recorder.

For connection of external instruments, there are three actual value outputs (terminals X5.2.32, X5.2.33, X5.2.34, against X5.1.13). The selectable signal levels are 0-10 volts, 0-20mA, 4-20mA or - setting different parameters at a maximum compliance voltage of 10V. In case of active ASM procedure, only two of these three analog outputs are freely available (terminal X5.2.32, X5.2.34).

Each output has its own D/A converter. By setting parameters, it is possible to adjust the outputs to stored-program controls, measuring instruments, etc.

For instance, the following values may be output:

- currents, voltages or power of the individual phases, total power
- minimum or maximum values
- set points
- phase angles

The signals of the analog outputs are updated in each line (VAR) or TAKT period. Actual values always relate to the previous period. In operation mode VAR at a net period (e.g. 50Hz:20ms) and in operation mode TAKT at T0 (e.g. 1 sec.). Different factors (e.g. set point variations, load varia-

tions, limiting and the influence of operating modes with SSSD and MOSI) give the actual value signals dynamic rations which can be smoothed with a smoothing stage. The MEAN (VALUE) parameter is applied here. The following setting is recommended: MEAN(VALUE) = 25.

### 4.11 CURRENT TRANSFORMER

By standard, each power section of the power controller has a current transformer. When using external current transformers, for instance on the secondary side of a transformer, these must be connected to the terminals X7.1 and X7.2 and terminated using a load resistor. Each external voltage transformer must be connected with an load resistor.

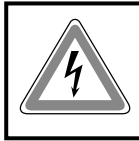

**CAUTION**

Danger of electric shocks.  
Current transformers must not be used without load resistors (secondary side), otherwise high voltages can occur at the terminals.



**ATTENTION**

Danger of damaging Thyro-P.  
Current transformers must not be used without load resistors (secondary side), otherwise high voltages can occur at the terminals.  
The load resistor must be designed so that at nominal current a voltage drop of 0.9 - 1.1Vrms occurs at the burden resistance.

The value of the used load resistor has to be entered with Thyro-Tool Family or LBA-2 in parameter U\_Load resistor.

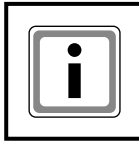

**REMARK**

The internal current transformers of Thyro-P, which are not needed when using external current current transformers, are jumpered by load resistor R40 on the control boards.

If load current monitoring of the phase 2 (not controlled) is desired for Thyro-P 2P, then an external current transformer and an external voltage transformer must be provided for this purpose.

CURRENT TRANSFORMER	TERMINAL X7.2	TERMINAL X7.1
phase L1	.11(k)	.12(l)
phase L2	.21(k)	.22(l)
phase L3	.31(k)	.32(l)

TAB. 11 CURRENT TRANSFORMER

The following parameters must be checked or adjusted:

**HARDWARE-PARAMETER**

Current transformer ratio $\ddot{u}$ :1, e.g. at 100A/5A transformer is $\ddot{u}=20$	UE_I
Type current in A (Primary current of transformer, e.g. 100A)	I_TYP
U_load resistor in V	U_load resistor (Voltage at load resistor)

**LIMITATIONS**

leff max	xxxx	A IEMA
----------	------	--------

This is conform to voltage at load resistor at nominal current of transformer.

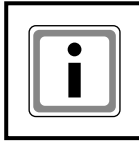
**REMARK**

Current measuring in not-controlled phases

Thyro-P 2P

Although phase 2 is not controlled in Thyro-P 2P, it is possible to take measuring values during this phase. A current transformer corresponding to T1 must be used and burdened (see type overview). It is connected as in table 23 to X7.1.22 – X7.2.21.

Thyro-P 1P

As only phase 1 is controlled with Thyro-P 1P, the measuring systems of phase 2 and 3 can be used freely. The corresponding current transformers (with max. 1V at nominal current) must be applied and burdened. Connection is carried out as in table 23 to terminal strips X7.1.22 – X7.2.21 for “phase 2”, and to X7.1.32 – X7.2.31 for “phase 3”.

The measuring values given do not influence the controller and are available for Bus interfaces, display and analog outputs. Parameter values must not be changed.

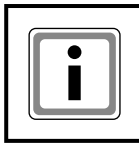
**REMARK**

Examples on how to calculate the Ohm value of load resistors

Example 1 Thyro-P 1P400-110 H

- the power controller is Thyro-P 1P 400-110H with 110A type current
- the transformer has a transformation ratio of  $tr = 100:1$

The currents of transformer are at nominal current of Thyro-P

- Primary current  $I_{rms\ primary} = 110\ A.$
- Secondary current  $I_{rms\ secondary} = 1.10\ A.$

The load resistor has to be dimensioned so that the voltage at load resistor is approx.  $1V_{eff}$  (0.9 - 1.1) at nominal current.

$$R_{burden} = \frac{1\ V_{rms}}{I_{secondary\ (of\ transformer)}} \quad \text{e.g.} \quad R_{burden} = \frac{1\ V_{rms}}{1,10\ A} = 0,909\ \Omega$$

It would be ideal to use a load resistor of  $0,909\ \Omega$ . If a resistor is not available with this value, it is possible to use a similar resistor. Minimum and maximum value of used resistor are:

$$R_{burden\ min} = \frac{0.9\ V_{rms}}{I_{secondary\ (of\ transformer)}} \quad \text{e.g.} \quad R_{burden\ min} = \frac{0.9\ V_{rms}}{1.10\ A} = 0,818\ \Omega$$

$$R_{burden\ max} = \frac{1.1\ V_{rms}}{I_{secondary\ (of\ transformer)}} \quad \text{e.g.} \quad R_{burden\ max} = \frac{1.1\ V_{rms}}{1.10\ A} = 1\ \Omega$$

After selecting a resistor, which value must be between  $0,818\ \Omega$  and  $1\ \Omega$ , the value has to be entered with Thyro-Tool Family or LBA-2 in parameter U\_Load resistor.

#### Example 2 Thyro-P 3P400-110 H

- the power controller is a 3-phase power controller of Thyro-P 3P 400-110H with 110A type current
- three similar current transformers with transformation ratio of  $tr = 100:1$

The calculation and selection of the three similar load resistor has to be done according to example 1.

After selecting the resistors, which value must be between  $0,818 \Omega$  and  $1 \Omega$ , the value has to be entered with Thyro-Tool Family or LBA-2 in parameter U\_Load resistor.

## 4.12 VOLTAGE TRANSFORMER

As standard, each power section is fitted with a voltage transformer for recording the load voltage. It is possible to measure voltages of up to 690V. The voltage transformers are wired to the control device A70 by the works.

LOAD VOLTAGE	TERMINAL X7.2	TERMINAL X7.1
phase L1	.15	.16
phase L2	.25	.26
phase L3	.35	.36

TAB. 12 VOLTAGE TRANSFORMER

In case of the power controller Thyro-P 2P, the voltage transformers output the voltages L1-L2 and L3-L1. To achieve a good resolution of the voltage measurement, 3 measuring ranges are provided. Selection of the ranges is performed by means of 4-pin bars, which have been set to the Power Controller type voltage by the works. The pin bars are found on the control device A70 above the terminal X7.

MAINS VOLTAGE	JUMPERS X501, X502, X503	MAX. MEASURING
230V	1 - 2	253V
400V	2 - 3	440V
500V respectively 690V	3 - 4	760V

TAB. 13 VOLTAGE MEASUREMENT JUMPER

If the jumpers are changed, then a change of parameters is required.

#### Hardware parameters

Type voltage	U_TYP
U rms max	UEMA
X501-3,1-2,2-3,3-4	TYP-BEREICH
Mains voltage	U_NETZ_ANW (Thyro-Tool Family)

Voltage readings of Thyro-P is equipped with 3 measurement ranges:

1. range: max. 15V (with internal transformer 230V)
2. range: max. 28V (with internal transformer 400V)
3. range: max. 45V (with internal transformer 500V / 690V)

The correct input voltage range (jumper) has to be selected when using an external voltage transformer.

The chosen input voltage range has to be set by Thyro-Tool Family or LBA-2 (Parameter: Voltage range).

Afterwards the voltage transformer ratio  $U_{\text{primary}} / U_{\text{secondary}}$  has to be entered in parameter (Voltage transformer ratio: UE\_U).

Example:

Usage of an external voltage transformer with  $U_{\text{primary}} = 500\text{V}$  and  $U_{\text{secondary}} = 25\text{V}$ .

Measurement range 2 will be selected due to  $U_{\text{secondary}} = 25\text{V}$ .

The following settings are necessary:

- Jumper of measuring channel (X501, X502, X503) to 2-3
- Parameter „Voltage range switchover“ (for LBA-2: „Voltage range“) has to be set to 400V (for LBA-2: „Voltage range“ to 400V)
- Parameter „Voltage transformer ratio“ to 20 ( $500\text{V}/25\text{V}=20$ ) (for LBA-2: „Voltage transformer ratio“ to 20)
- Parameter „Power controller connection voltage“ ( $U_{\text{Type}}$ ; for LBA-2: „Type voltage“) to primary voltage of used transformer (here 500V) (for LBA-2: „Type voltage“ to the primary voltage of used transformer (here 500V))

#### REMARK

Voltage readings in not-controlled phases

Thyro-P 2P

Although phase 2 is not controlled with Thyro-P 2P, it is possible to take measuring values during this phase. The voltage transformer suitable for standard rail assembly (order no. 2000000399) is to be used. Connection is made as in table 21 to X7.1.26 – X7.2.25. The maximum induced voltage of the transformer (incl. over-voltage) must be less than 50 volts.

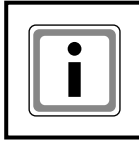

Thyro-P 1P

As only phase 1 is controlled with Thyro-P 1P, the reading systems of phase 2 and 3 can be used freely. The voltage transformer suitable for rail assembly (order no. 2000000399) is to be used. Connection is made as in table 23 to terminals X7.1.26 – X7.2.25 for “phase 2” and X7.1.36 – X7.2.35 for “phase 3”.

The measuring values do not influence the controller and are available for Bus interfaces, display and analog outputs. Parameter values must not be changed.

#### 4.13 OTHER CONNECTIONS AND TERMINAL STRIPS

	ROOT*	BREAK CONTACT	CLOSER
Alarm relay K1	X2.7	X2.8	X2.9
Limiting K2	X2.10	X2.11	X2.12
Option K3	X2.13	X2.14	X2.15

\* tie point

TAB. 14 TERMINAL STRIP X2 FOR K1, K2, K3

X5.1	FUNCTION	X5.2	FUNCTION
5	+5V	5	+5V

13	ground 5V	10	set point 1
13	ground 5V	11	set point 2
13	ground 5V	32	analog output 1
13	ground 5V	33	analog output 2
13	ground 5V	34	analog output 3
13	ground 5V	16	ASM input
21	+3,3V	17	GSE input
14	ground 24V	12	RESET
14	ground 24V	15	controller lock
14	ground 24V	18	SYT9 connection
14	ground 24V	19	QUIT
20	+24V*	20	+24V*

\* Loading:  $I_{X5,1,20} + I_{X5,2,20} + I_{X21,9} \leq \text{max. } 80\text{mA}$

TAB. 15 TERMINAL STRIP X5 IN THE CONTROL DEVICE

Terminal strip X6 in the control device

At the terminal strip X6, wiring between the control device A70 and the control cards A1, A3 and A5 of the power section is performed by the works. Allocation of the terminal strip is as follows:

X6	Name
11	thyristor L1 neg.
12	+5V
13	thyristor L1 pos.
21	thyristor L2 neg.
22	+5V
23	thyristor L2 pos.
31	thyristor L3 neg.
32	+5V
33	thyristor L3 pos.
41	input temperature sensor
42	ground temperature sensor

TAB. 16 TERMINAL STRIP X6

Each thyristor is controlled by 20mA current supply switching to ground.

The ventilator monitor is connected to the terminals X6.41 and X6.42 in separately ventilated devices (..HF). The temperature of the power section is monitored using a PT 1000 temperature sensor. In case of overheating of the power section, for instance caused by outage of the ventilator, a fault indication is generated and the alarm relay is activated (default values). The temperature may be enquired by the interfaces.

#### 4.14 SYNCHRONIZATION

By standard, each power section is fitted with a transformer for an input voltage of up to 690V.

After filtering, the synchronization signal for control of the thyristors is generated from the secondary voltage. The connections are wired by the works. This includes the following terminals:

TERMINAL STRIP X7

X7.1	X7.2	NAME
12	11	current transformer phase L1
14	13	sync phase L1
16	15	load voltage phase L1
22	21	current transformer phase L2
24	23	sync phase L2
26	25	load voltage phase L2
32	31	current transformer phase L3
34	33	sync phase L3
36	35	load voltage phase L3

TAB. 17 TERMINAL STRIP X7

For the synchronization the following jumpers are necessary on the componentry of the control device.

THYRO-P	SHORT CIRCUIT JUMPER	
1P	X507	X508
2P	X507	-
3P	-	-

TAB. 18 SYNCHRONIZATION JUMPER

4.15 COMPONENT MOUNTING DIAGRAM CONTROL DEVICE

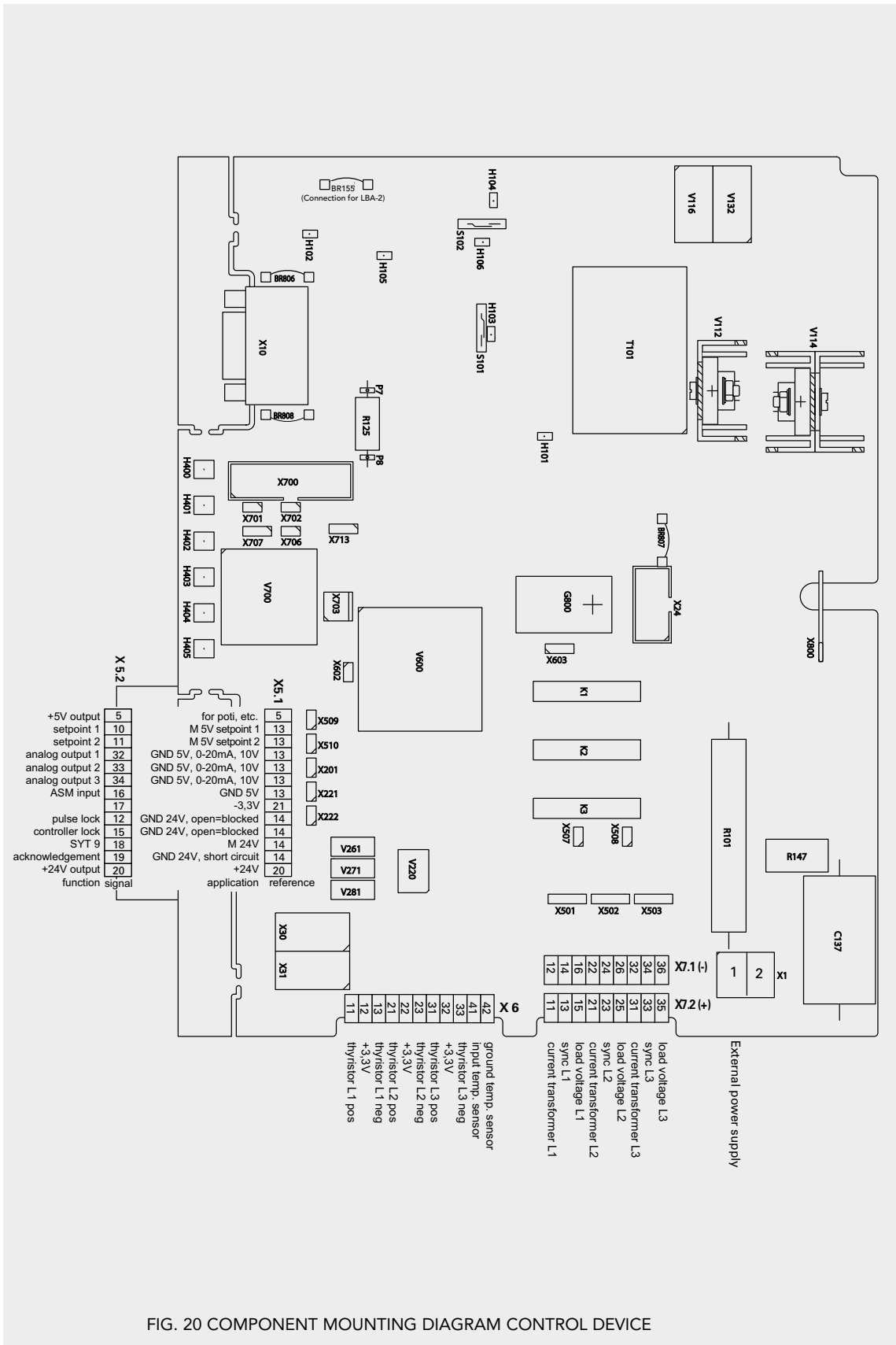

FIG. 20 COMPONENT MOUNTING DIAGRAM CONTROL DEVICE

## 5. INTERFACES

Necessary process optimization as well as the requirements made of high, continuous and documentable quality in production processes often require the use of digital process communications. It allows interlinking of many signals and enables their evaluation in an efficient manner.



With the power controller Thyro-P, the following interfaces may be used for this (see also fig. 11 on previous page):

- X10, RS232 (optional with Bluetooth adapter or LBA-2)
- X30, fibre optic receiver
- X31, fibre optic transmitter

as well as optional interfaces, for instance

- X20, bus interface, e.g. for Profibus DPV1, Profinet, DeviceNet, Ethernet IP, Modbus RTU or Modbus TCP
- X40 dASM input
- X41 dASM output

All internally processed data like current, voltage, power, set point value, limitations, etc. may be enquired, processed and modified during operation (online operation) in master-slave process. Under assistance of corresponding automation technology, it is possible to do without connection of process controls, potentiometers, instruments, LBA-2, etc.

The existing interfaces may operate simultaneously, so that for instance the following system configuration would be possible: a stored-program control via Profibus supplies the set points, a PC visualizes (fibre optic interface/Thyro-Tool Family) the data and on location the device status and selected operating values are displayed via LBA-2 (using the RS232).

Therefore, the power controller Thyro-P is transparent to all levels of production and the process may therefore be securely handled.

## 5.1 RS232 INTERFACE

The isolated RS232 interface is provided for direct connection of an LBA-2 (with cabinet installation kit also indirect via cable) or a PC. Setting of parameters of the interface is performed using Thyro-Tool Family or LBA-2. The default baud rate is set to 9600 baud, no parity, 8 data bits, 1 stop bit.

The following illustration shows connection of a Thyro-P to a PC using the RS232 interface (also possible via fiber optic or Profibus).

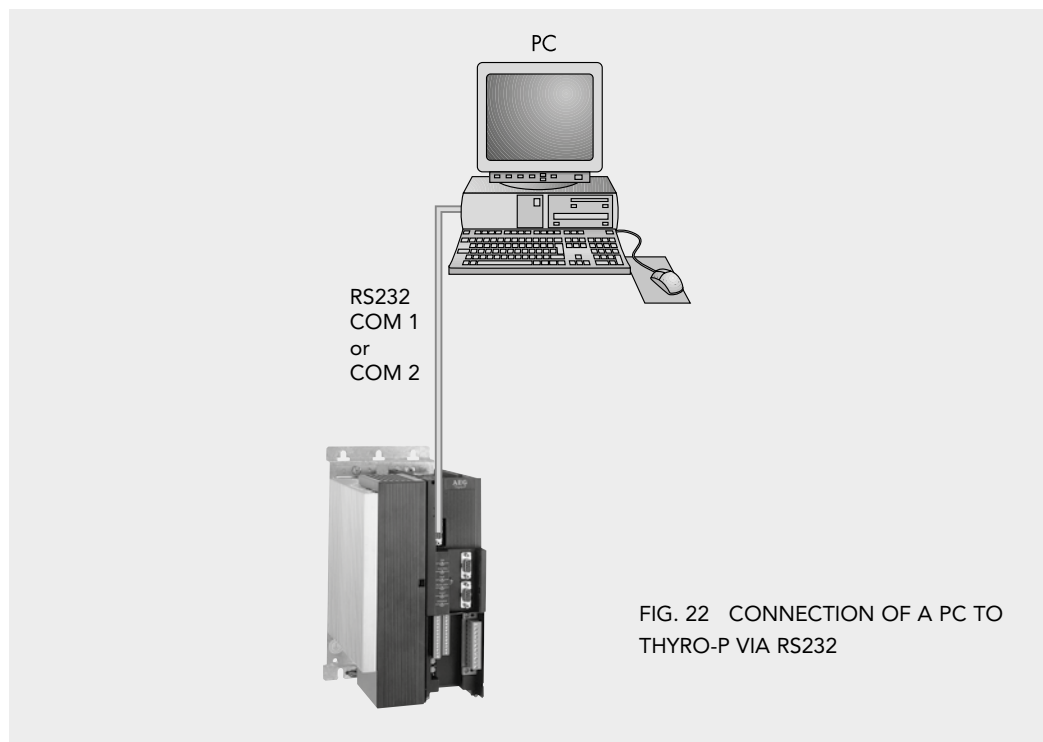

FIG. 22 CONNECTION OF A PC TO THYRO-P VIA RS232

For connecting the PC, an RS232 cable is required. On the Thyro-P side, a 9-pin sub-D plug and on the PC side a 9-pin sub-D socket must be available.

The connecting socket X10 of the power controller is allocated as follows (1:1 connection):

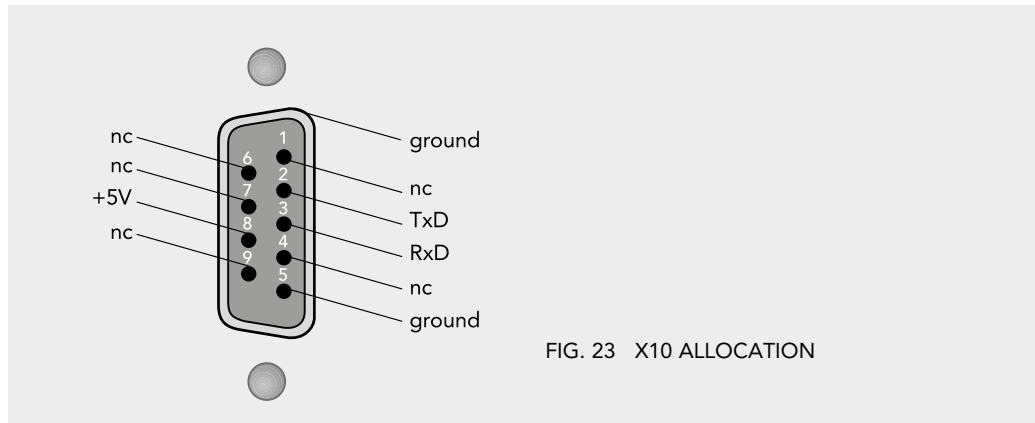

FIG. 23 X10 ALLOCATION



### ATTENTION

The LBA-2 receives its power supply (+5V) via pin 8 of the socket X10. It is imperative that this voltage is not short-circuited. Otherwise, damage to Thyro-P may be incurred.

If a PC is connected to the RS232 interface, then this pin should be left unconnected, since it is not needed for data transfer.

Generally, all devices with an RS232 interface may communicate with Thyro-P. The protocol used may simply be created by the user himself.

For this purpose, a detailed description of the protocol used may be requested from Advanced Energy Industries (refer to application document).

## 5.2 FIBER OPTIC INTERFACE

This widely used interface (LL, X30 LLE blue, X31 LLS grey) for quick and secure data transfer is fitted to Thyro-P as standard and enables connection of up to 998 Thyro-P power controllers. Due to the good interference immunity, larger distances can be bridged and data can be transferred at higher speeds.

To install a fiber optic system, the following interface components can be used.

### 5.2.1 FIBER OPTIC DISTRIBUTION SYSTEM

Using the components described below, a complete fiber optic system for connection of up to 998 Thyro-P may be created.

#### SIGNAL CONVERTER RS232 / FIBER OPTIC

Connection of the fiber optic to the PC interface (RS232) is performed using the fiber optic / RS232 signal converter shown below. Power supply is via the plug-in power supply enclosed.

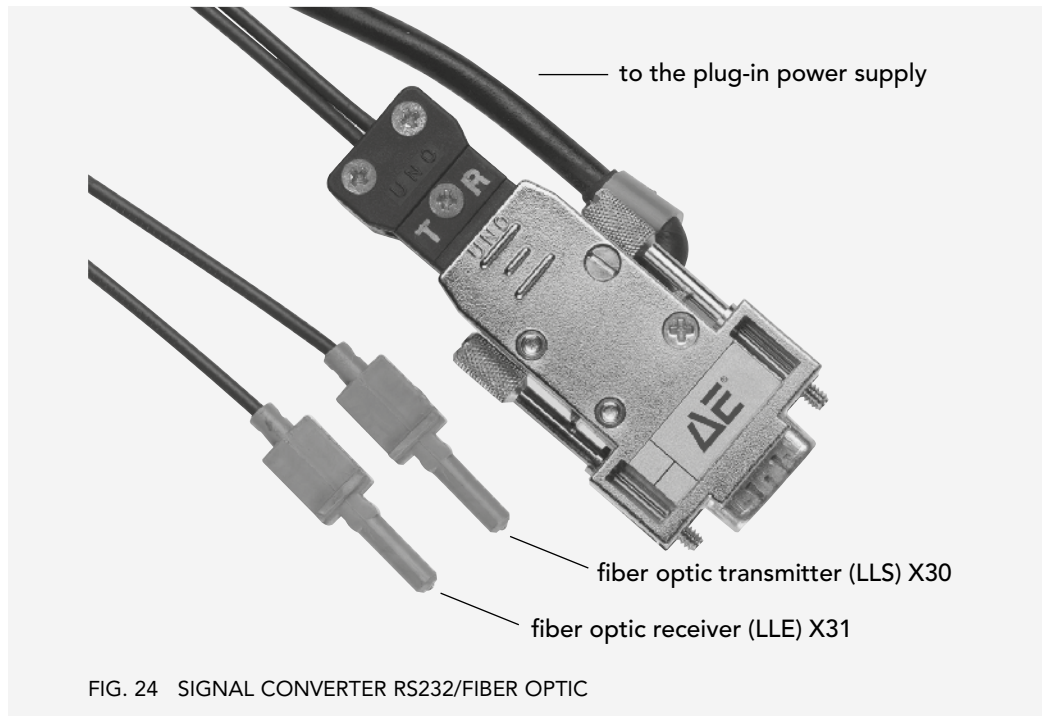

FIG. 24 SIGNAL CONVERTER RS232/FIBER OPTIC

**LLV.V**

The fiber optic distributor supply LLV.V is the basic component for the fiber optic system. It serves to connect star distributors and to amplify the light signals received. Its power supply is sufficient for supply of five fiber optic distribution components of the type LLV.4.

The amplification of LLV.V in the fiber optic data path is sufficient for increasing the distance for each LLV.V by about 50 m, so that overall longer transmission paths are possible then.

**LLV.4**

The fiber optic distributor LLV.4 is connected to the base component LLV.V. It is able to distribute the optical signal to respectively receive from four connections and therefore multiplies the signal from the computer to Thyro-P by four units each. The maximum distance from LLV.4 to Thyro-P should not exceed about 25 m.

In case of optimum installation conditions (number of bends, connection mounting, etc.), the distances stated in the following table may be realized:

DEVICE	PC	LLV.V	LLV.4	THYRO-P
PC	--	50 m	--	25 m
LLV.V	50 m	50 m	--	25 m
LLV.4	--	50 m	--	25 m
Thyro-P	25 m	25 m	25 m	--

TAB. 19 FIBER OPTIC DISTANCES

The following figure shows the fibre optic system with LLV, Thyro-P and PC.

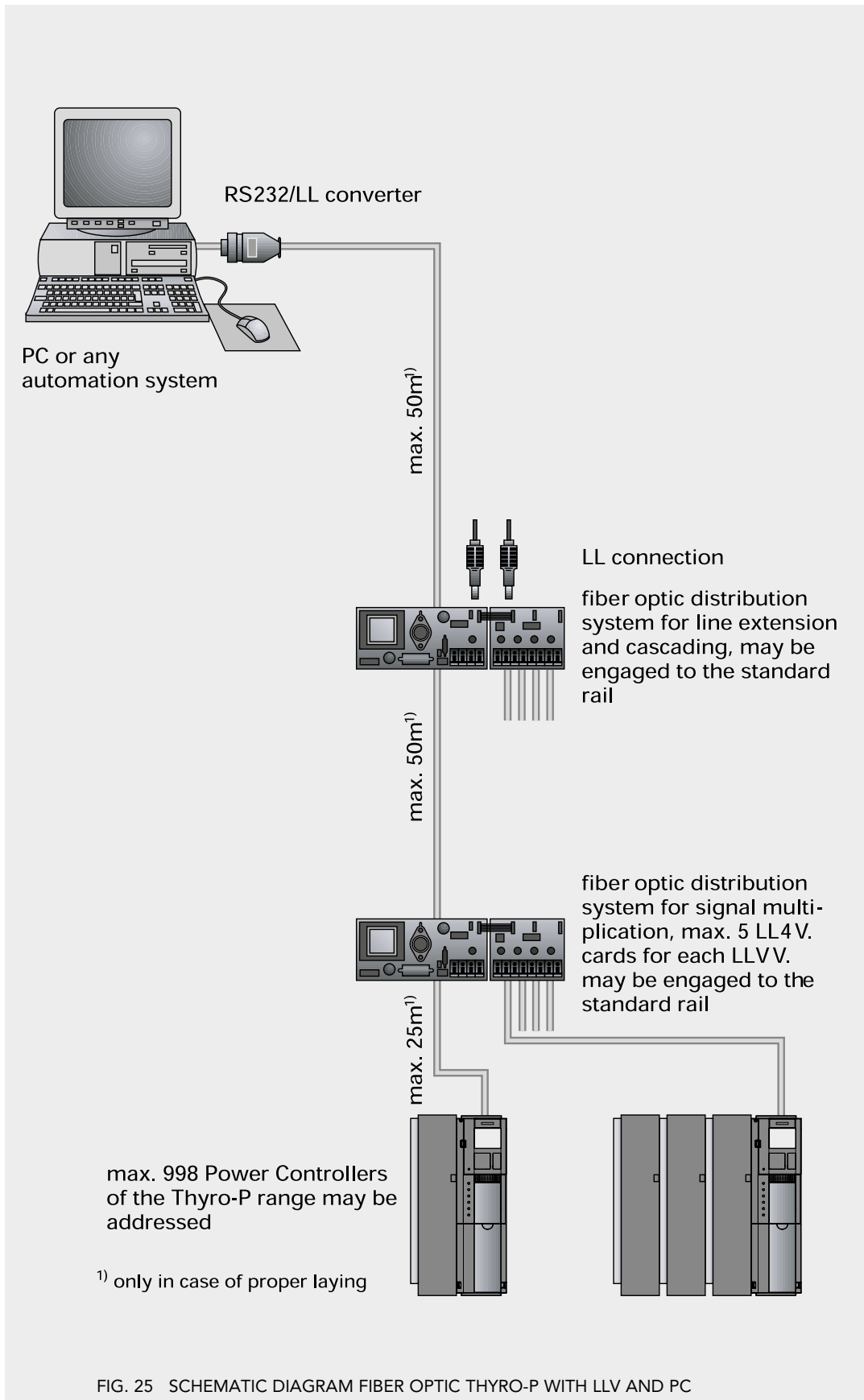

### 5.3 BUS INTERFACES (OPTIONAL)

The control device of Thyro-P may be optionally fitted with interface cards, e.g.

- Profibus DPV1
- Profinet
- DeviceNet
- Ethernet IP
- Modbus RTU
- Modbus TCP

All available interface cards support the usage of motor potentiometer feature for set point processing.

If the motor potentiometer feature is not used, signals can be transmitted on three inputs (Input 0, Input 1 and Input 2) of the bus interface via bus to the higher control system.

Further information are available in the corresponding operating manuals.

Further interface cards are available on request.

## 6. MAINS LOAD OPTIMIZATION FOR OPERATING MODE TAKT

In operating mode TAKT, mains load optimization is possible for multiple power controller applications in the following described ways. The most efficient way is to use the digital and dynamic dASM process. Furthermore it is possible to use previous dynamic ASM procedure or statistic SYT-9 procedure for mains load optimization. By using mains load optimization there are considerable advantages: reductions of mains load peaks and reaction shares, smaller design sizes (e.g. of transformer, power supply and other installation) and associated lower operating- and investment costs.

### 6.1 dASM MAINS LOAD OPTIMIZATION

The complete digital dASM procedure offers the option of dynamic mains load optimization when multiple Thyro-P power controllers operate in operating mode TAKT.

#### FOR COMMISSIONING

While being easy to handle, Thyro-P offers the following important advantages with its digital and dynamic operating mains load optimization:

- Considerable reduction of peaks loads for the mains
- Evenly distributed load for the mains
- Consideration of setpoint changes at mains load optimization
- Consideration of load changes at mains load optimization

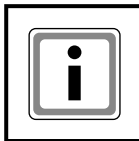

#### NOTE

dASM can be applied whenever multiple Thyro-P power controllers operate together on a common grid supply in the operating mode TAKT.

#### OTHER FEATURES

The grid load optimization dASM of the Thyro-P provides the following additional features:

- Grid load optimization for up to 32 Thyro-P power controllers in the operating mode TAKT
- Grid load optimization on the basis of power consumption of the connected loads
- Dynamic grid load optimization, i.e. including the observance of set point- or of the load alterations
- Digital operation and communication
- Grid load optimization of the dASM group within up to circa 5 seconds
- Suitable for 1 or 3 phase applications (Thyro-P 1P or Thyro-P 2P / Thyro-P 3P)
- The simplest dASM wiring with RJ45 patch cables (Ethernet CAT 5 8-pole) with a cable length between 2 power controllers of up to 100m (depending on surrounding conditions)
- Simple parameterization (only for the master: power limit, number of devices)
- Monitoring of the grid load (power limit)

#### APPROACH FOR dASM APPLICATION

- In design it is important to ensure an even distribution of the electric load onto the three-phase system being used.
- Installation, parameterization and initiation of the individual Thyro-P devices in the operating mode TAKT (with the same TAKT cycle period  $T_{\text{c}}$ )
- Checking the power wiring is correct for the phases
- Wiring the RJ45 patch cables (Ethernet CAT 5 8-pole) for dASM communication
- Commissioning of the dASM group

### Installation of the dASM control cables

With regards to the dASM procedure there are a few simple rules which need to be adhered to when installing the control devices:

- For 1 and 3 phase loads separate dASM groups must be wired up.
- Power controllers and loads of a dASM group must be connected to the same grid in phase.
- The connection of the RJ45 patch cables (Ethernet CAT 5 8-pole) is made on the underside of the control device in accordance with the following illustration to connectors X41 (output) and X40 (input):

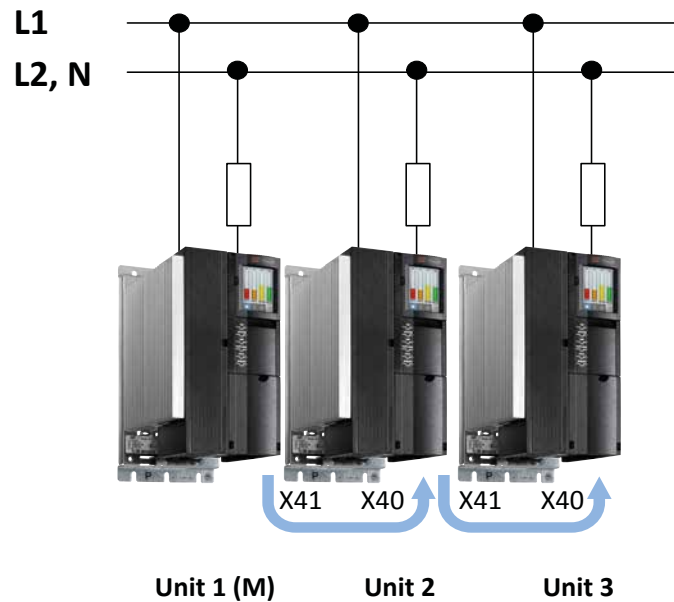

FIG. 26 WIRING OF THE dASM SIGNAL CABLES

The 4 LEDs on the RJ45 connectors serve to check the RJ45 wiring as well as that the dASM data transmissions via the dASM control cables are running smoothly.

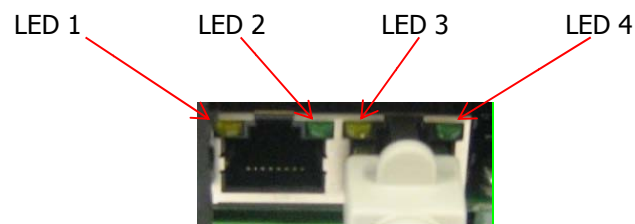

FIG. 27 LEDS ON THE RJ45 CONNECTORS

The LEDS can be interpreted as follows:

CONNECTOR	LED	COLOUR	STATUS	INTERPRETATION
X40	1	yellow	OFF	A connection to the preceding device (in the direction of the master) is in place
X40	1		FLASHING	Not all data could be sent to the preceding (in the direction of the master) device (dynamic communication error)
X40	1			If LED 3 is also flashing then a ring has been made with the RJ45 cables
X40	1		ON	There is no RJ45 cable connected
X40	1			Connector incorrectly connected
X40	1			(the RJ45 cable is not inserted into X41 of the preceding Thyro-P)
X40	2	green	OFF	An incorrect cable was used (e.g. cross-over cable instead of the necessary patch cable)
X40	2		FLASHING	Thyro-P is switched off
X40	2		ON	Thyro-P is master
				Thyro-P is connected to the preceding device (in the direction of the master)

CONNECTOR	LED	COLOUR	STATUS	INTERPRETATION
X41	3	yellow	OFF	Connection to the next slave is in place
X41	3		FLASHING	More than 32 units are connected in the dASM group
X41	3			If LED 1 is also flashing then a ring has been made with the RJ45 cables (then: no device is master, no dASM functionality)
X41	3		ON	There is no RJ45 cable connected
X41	3			Connector incorrectly connected (the RJ45 cable is not inserted into X40 of the preceding Thyro-P)
X41	3			An incorrect cable was used (e.g. cross-over cable instead of the necessary patch cable)
X41	4	green	OFF	No additional units are connected
X41	4		FLASHING	The additional units form their own group
X41	4		ON	Additional units are in the same group

Installation of the power units for dASM operation

Amongst other things the following points are important for successful installation of dASM grid load optimization

- Power/grid connection of all power controllers to be executed in phase (see the diagrams of the following examples 1, 2, 3).
- dASM control cable connection (RJ45 patch cable) running from dASM master to the final Thyro-P unit (see the diagrams of the following examples 1, 2, 3)

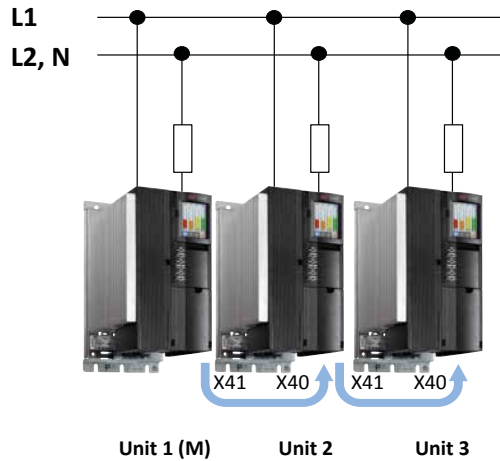

Installations examples

Example 1

This diagram shows 3 one phase Thyro-P power controllers with in phase grid connection, connected to 2 phases of a three-phase network or a single-phase network, along with dASM wiring. The dASM grid load optimization is operating on the example with all connected and switched on Thyro-P units 1-3.

dASM group of unit 1 (M): 3 x Thyro-P

The device labelled unit 1 is operating in this configuration as the dASM master of dASM group 1. In total the dASM group can consist of up to 32 Thyro-P devices. Additional

dASM groups of up to 32 Thyro-P devices operating independently of one another group can be connected to the same grid so the number of Thyro-P devices which can be operated with dASM grid load optimization can, in principle, be as large as desired.

Alongside the dASM control cable connection (RJ45 patch cable), which is required for all units, the power/grid connection, in each case in phase, is a prerequisite for the formation of a dASM group.

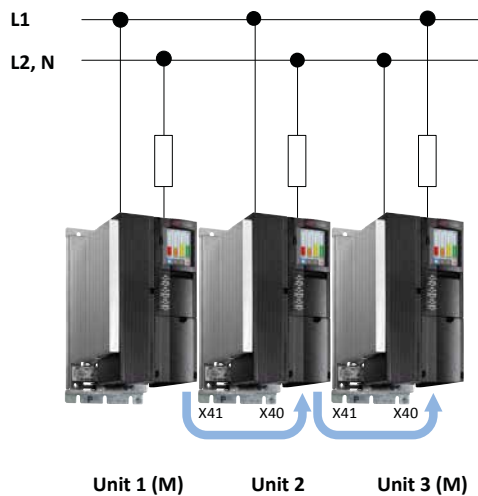

Example 1a

This diagram shows 3 single-phase Thyro-P power controllers with a grid connection which is not in phase, connected to 2 phases of an three-phase network, or a single-phase network, also with dASM wiring. Due to the connection of unit 3 not being in phase with regards to the preceding unit 2, unit 3 autonomously forms a new master (however operates independently from units 1 and 2). This is why the grid load optimization in this example only operates with units 1 and 2, which means that, as a result of the connection not being in phase, the switching here, in comparison with the switching in example 1, does not lead to optimal grid load optimization.

dASM group from unit 1 (M): 2 x Thyro-P

dASM group from unit 3 (M): 1 x Thyro-P

### Example 2

In the following diagram 3 dASM groups are connected to the three-phase network with three single-phase Thyro-P devices each.

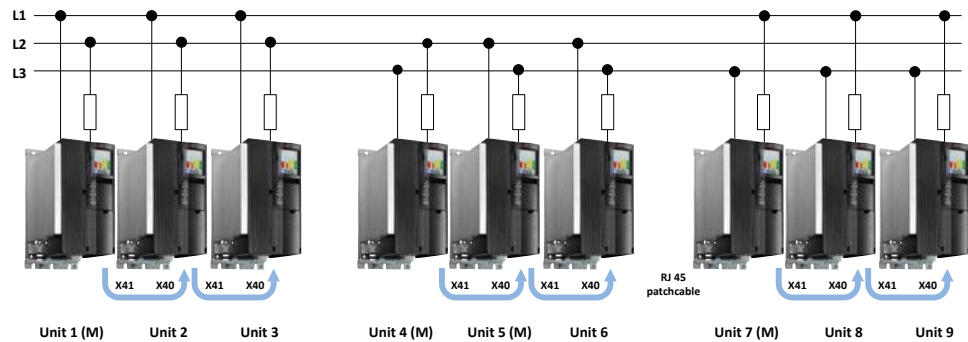

Even in a case where patch cables were connected between units 3 and 4, or 6 and 7, this configuration would generate the 3 dASM groups illustrated. This is caused by the varying activation of the Thyro-P devices in the power grid (unit 3 ≠ unit 4 unit 6 ≠ unit 7).

The first Thyro-P in the dASM group in each case takes on the master function for grid load optimization of the dASM group. For an activation unit setup with 3 dASM groups up to  $3 \times 32 = 96$  Thyro-P devices could be connected.

Because as many dASM groups with 32 Thyro-P devices each can be realized for grid load optimization, assemblies which are as large as desired (with as many Thyro-P devices in total as desired) can be equipped with grid load optimization.

Example 3 shows the following configuration:

dASM group from unit 1 (M): 3 x Thyro-P

dASM group from unit 4 (M): 3 x Thyro-P

dASM group from unit 7 (M): 3 x Thyro-P

Example 2a:

In contrast to example 2 the power wiring of Thyro-P unit 4 is not connected in phase with units 5, 6. This is why, in the diagram which follows, the following configurations have arisen:

dASM group 1: unit 1 (M): 3 x Thyro-P

dASM group 2: unit 4 (M): 1 x Thyro-P

dASM group 3: unit 5 (M): 2 x Thyro-P

dASM group 4: unit 7 (M): 3 x Thyro-P

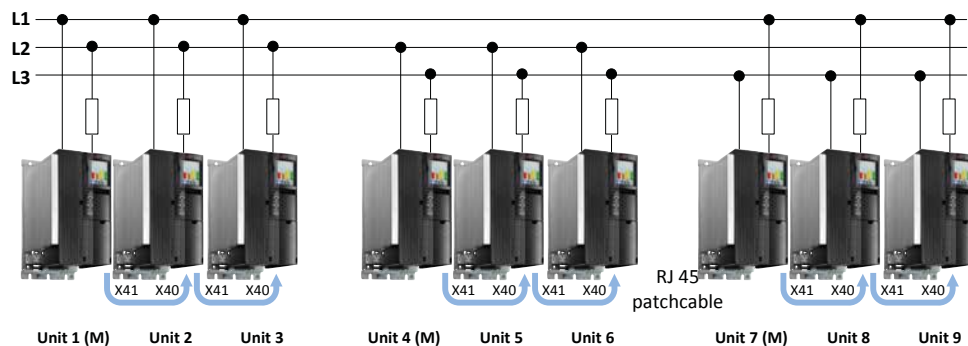

As a result of the connection not being in phase in this switching arrangement, in contrast with the switching arrangement from example 2, a suboptimal grid load optimization occurs.

### Example 3

The following illustration shows a total of 6 power controllers with symmetrical load distribution in a three-phase network:

4 Thyro-P 2P power controllers

2 Thyro-P 3P power controllers

All ThyroP units in the following diagram are set up with an in phase grid connection.

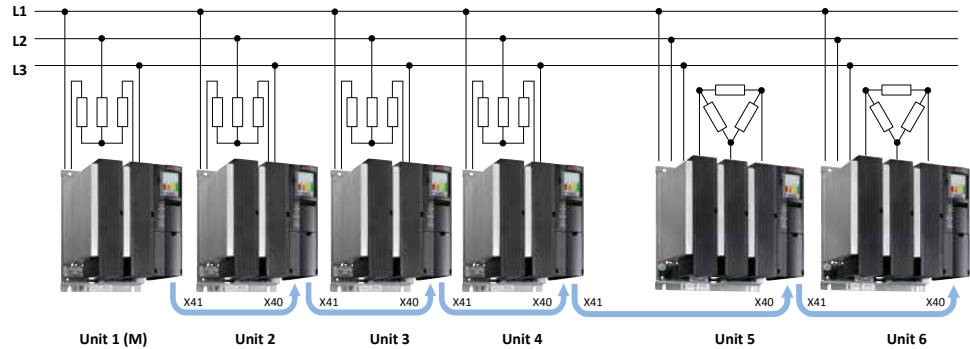

The device labelled unit 1 operates in this configuration as a dASM master for all units, as units 5 and 6 are connected in phase with units 1 to 4.

### dASM commissioning

To ensure optimal functionality of the dASM grid load optimization the following must be adhered to when commissioning:

- Check Thyro-P for in phase grid connection
- Check wiring of patch cable
- Select operating mode TAKT (with same TAKT cycle period) for all Thyro-P devices
- Parameterization of the master units:
  - dASM NO. OF DEVICES
  - dASM POWER THRESHOLD [W]
- Start up of the dASM group (=>switch-on)

### dASM notification

The dASM grid load optimization generates the following notifications in the master unit should errors arise:

- dASM device number is incorrect:
  - check patch cable connections/parameter dASM device number
- dASM power limit has been exceeded: reduce set points of the assembly as appropriate

The notifications generated can be reported via:

- data logger,
- LED,
- Relay,
- LBA-2 (in preparation) or
- Thyro-Tool Family

### ERRORS IN dASM COMMUNICATION

Should the dASM communication become interrupted (for example, an interruption between unit 6 and unit 7) during operation of the assembly e.g. as the result of a cable break or similar, then a new master is automatically generated in the system beyond the point of interruption during operation – the dASM system continues to run and unit 1 now operates only as a master for units 1-6 and displays that only 6 units are present in the dASM network. Notification: "dASM device number is incorrect".

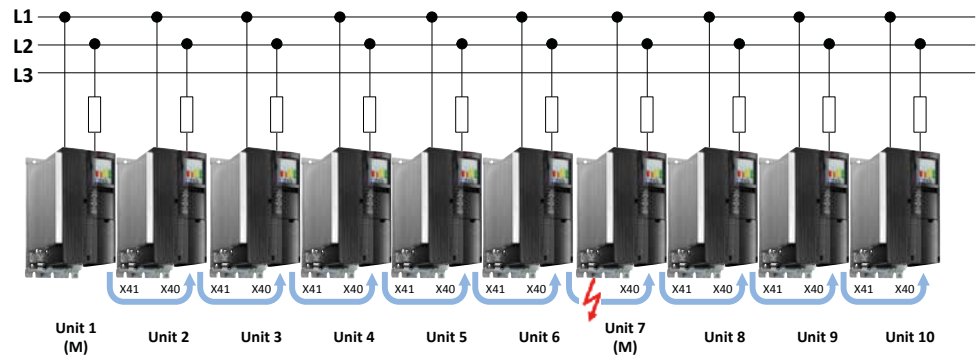

Unit 7 now operates additionally as a master for units 7-10.

The quality of grid load optimization of the two now newly formed dASM groups (units 1-6, units 7-10) is of a similar level to the previously formed dASM group units 1-10.

## 6.2 SYT-9 PROCEDURE

A process for static mains load optimization: minimizes mains load peaks and associated mains reaction shares. For the SYT-9 process, set points and load changes are not automatically included in mains load optimization.

The SYT-9 process requires an additional component. For Thyro-P, it should only be employed in connection with already installed controllers (Thyro-M, Thyrotakt MTL) under SYT-9 process.

Then, the pulse of the SYT card must be connected to the terminal X5.1:18 and ground to X5.1:14. On the Thyro-P Power Controller, the jumper X201 (behind X5) must be pulled off. For this purpose, the texts BAL 00180 and operating instructions SYT-9 must be observed as described under Thyro-M.

THYRO-P NO.	SYT9 NO. 1	THYRO-P NO.	SYT9 NO. 1
1	X5.2.5 - A10	1	X5.2.18 - C10
2	- A12	2	- C12
3	- A14	3	- C14
4	- A16	4	- C16
5	- A18	5	- C18
6	- A20	6	- C20
7	- A22	7	- C22
8	- A24	8	- C24
9	- A26	9	- C26

Connection of up to 9 Thyro-P at one SYT9-Module

## 6.3 SOFTWARE SYNCHRONIZATION

By means of different settings in the storage location SYNC\_Adresse, a different startup of the individual power controllers (counter x 10ms) may be achieved. The counter is set to 0 after switching on the mains or RESET. While the counter is running, the power controller is switched passive, as during controller lock.

It is possible to enter values in SYNC\_Adresse larger than the clock time T0. Then, startup of the power controller is only during the next clock time. For instance, in an emergency power plant, slow switching of the total load is possible. The max. delay is 65535 x 10ms. This value also forms the base setting for the ASM process.

### 6.4 ASM PROCEDURE (PATENTED)

In systems, in which several equal power controllers are operated in the operating mode TAKT, the ASM process may be sensibly used for dynamic and automatic mains load optimization in multiple Power Controller applications. This patented world premiere independently minimizes mains load peaks and therefore mains reaction shares during the current process. In case of the ASM process (automated synchronization of multiple controller applications), changes in set point and load (for instance due to temperature-dependent load) are included in mains load optimization online. Especially when using heating elements with a large aging effect, which during new operation have high current amplitudes with short startup time, lower investment cost may be achieved. For the ASM process the controller requires an ASM control device. An additional burden resistor is used for all controllers. Schematic wiring of power controllers for the ASM process can be seen in the following illustration:

When using the ASM option, the analog output 2 (X5.2.33 against ground X5.1.13) becomes an output proportionate to the current during the on-period  $T_s$ . All power controllers connected to synchronization work on the same external burden. The burden resistor is calculated approximately as

$$R_{burden} [k\Omega] = 10V / (n \times 20mA) \quad n = \text{number of power controller}$$

The burden voltage is measured at the ASM input. The Power Controller searches within the clock control the place with the lowest mains load.

Due to this automated, independent procedure, the process chain is ensured through the temperature control circuit and the power controller without effects; negative effects like flicker and subharmonics of the mains frequency are balanced out during a current dynamic process. In this case, unfavorable short-term overlapping may occur, for instance after set point jumps or voltage swing. The application document ASM-procedure gives further information on this.

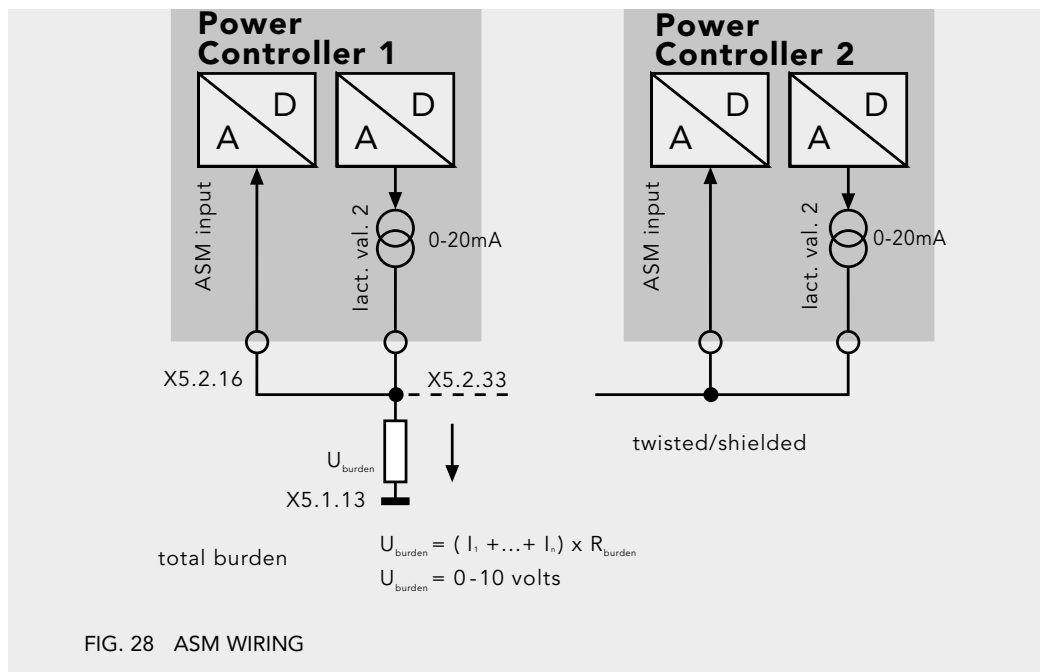

## 7. MAINS LOAD OPTIMIZATION VSC

### General

Alongside being highly dynamic, regulated heating processes with power controllers in VSC connection offer considerable advantages for practical usage in terms of reducing operating costs through savings in electricity charges. This is a result of

- Considerable reduction in reactive power
- Considerable improvement of power factors
- Significant reduction in grid harmonics.

The Thyro-P...VSC now also provides the user with series power controllers as an option for grid load optimized, highly dynamic heating processes. Primary or secondary VSC connections in two or three stage format can be realized.

### BASIC CONNECTIONS

#### PRIMARY VSC

This VSC connection is particularly suitable for large load currents (e.g.  $I_{Load} > I_{Controller}$ ) with smaller voltages. One transformer for each load. The illustrations show the two and three stage VSC connection. Details can be found in the Thyro-P...VSC connecting diagrams.

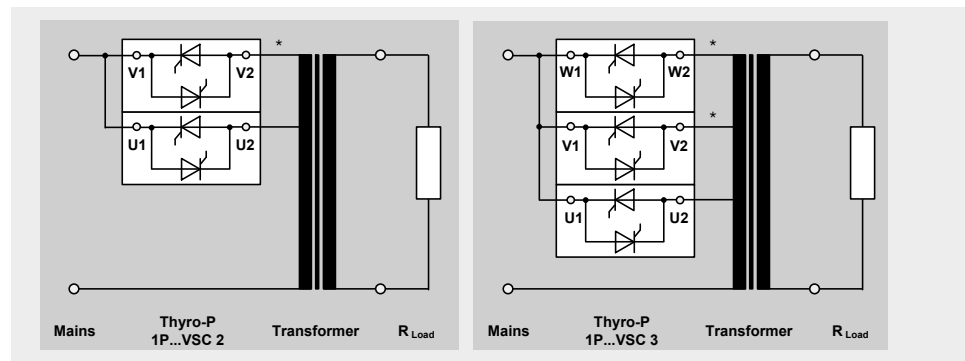

#### WARNING

As inherent to their functional principle, a higher voltage occurs than the mains voltage at spots marked with \*. The transformer is to be constructed as there are not more than 690 V present. Otherwise it can lead to considerable damage to the device.

#### SECONDARY VSC

This VSC connection is particularly suitable if lots of heaters are being supplied from one transformer. Through the improvement of the power factor a larger transformer can dispense more active power and, as such, supply additional loads, if required.

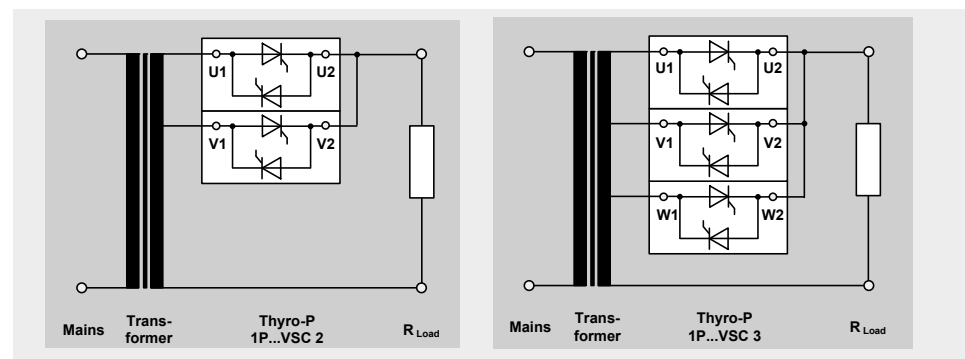

## OTHER FEATURES

If load monitoring is required with the VSC connection then external converters are needed on the secondary side.

The wiring required by the type series Thyro-P...VSC is different with regards to both the power and control connections when compared with standard power controllers from the type series Thyro-P.

## OPERATING WITH LBA-2

To operate the VSC power controllers you need software for the LBA-2 version V1.2. or higher. If you only have older versions then you can get a free update for the LBA-2 from our support team.

## OPERATING WITH THE THYRO-TOOL FAMILY

The Thyro-Tool Family from version 4.06 can be used to operate the VSC power controllers.

If you have already purchased an older version of the Thyro-Tool Family software you can upgrade the software with a free update from our home page.

## OPERATING MODES

The power controllers in the series Thyro-P 1P..VSC only have one operating mode: VSC\_VAR

## REGULATION MODES

All regulation modes of the Thyro-P are available as regulation modes: U, U<sup>2</sup>, I, I<sup>2</sup>, P.

In primary VSC regulation mode U and U<sup>2</sup> are less suited.

## LOAD MONITORING

For the application of load monitoring external converters are needed for L1 on the secondary side (also see the Thyro-P VSC connecting diagrams in chapter 8 as well as chapters 4.10 and 4.11 of operating instructions). The parameters for this can be configured with the Thyro-Tool Family or LBA-2.

Parameterization:

- Operating mode
- Number of VSC stages
- External converters
- Overlapping\*

\* Using overlapping parameters

The overlapping process is for linearization of the control characteristic line and can be used on request. In this case the next higher step will already be activated before full conducting the small step. The change is only marginal regarding  $\cos \phi$ .

Within a half wave cycle up to 3 thyristor stages can be activated, however, in reality only one is ever switched on. As such, the advantages of a very good level of efficiency in terms of the thyristor controllers is retained in full.

## 8. CONNECTING DIAGRAMS

8.1	THYRO-P 1P	1-PHASE POWER CONTROLLER
8.2	THYRO-P 2P	2-PHASE POWER CONTROLLER
8.3	THYRO-P 3P	3-PHASE POWER CONTROLLER
8.4	THYRO-P VSC 2	2-STEP PRIMARY VSC
8.5	THYRO-P VSC 3	3-STEP PRIMARY VSC
8.6	THYRO-P VSC 2	2-STEP SECONDARY VSC
8.7	THYRO-P VSC 3	3-STEP SECONDARY VSC

### 8.1 THYRO-P 1P 1-PHASE POWER CONTROLLER

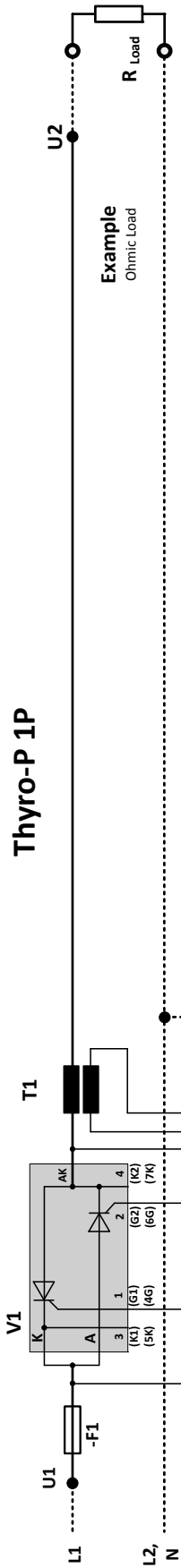

#1) for 690V types: separate power supply is required  
 all other types: separate power supply is possible  
 #2) Default setting  
 # option  
 Remarks

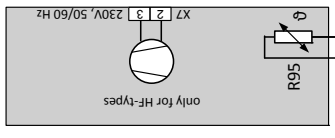

\* external fuse is required:  
 2A slow acting

Thyro-P Control Device		Power Section Driver A1		Power Section Driver A3		Power Section Driver A5		A70	
<b>Broad band Power Supply</b>	<b>Input</b> 230 VAC -20% to 500 VAC +10%	<b>Power Supply</b> Output 5V / 1mA	<b>Analog Inputs (set point)</b> Set point 1 Set point 2	<b>DC Eliminator Input</b> +5V +3.3V	<b>Mains Load Optimization</b> ASM #) dynamic static SYT9 static dynamic dASM-Input dynamic	<b>Analog Outputs (actual values)</b> Output 1 Output 2 Output 3	<b>Control Inputs</b> RESET Controller lock QUIT M (24V)	<b>Power Supply</b> Output 24V / 80mA +24V	<b>Interfaces</b> Fibre Optic Connector Transmitter Receiver
X1	X5.1	X10	X16	X21	X23	X25	X26	X30	X31
X2	X5.2	X11	X17	X22	X24	X27	X28	X32	X32
X3	X5.3	X12	X18	X23	X25	X28	X29	X33	X33
X4	X5.4	X13	X19	X24	X27	X30	X31	X34	X34
X5	X5.5	X14	X20	X25	X29	X31	X32	X35	X35
X6	X5.6	X15	X21	X26	X30	X32	X33	X36	X36
X7	X5.7	X16	X22	X27	X31	X33	X34	X37	X37
X8	X5.8	X17	X23	X28	X32	X34	X35	X38	X38
X9	X5.9	X18	X24	X29	X33	X35	X36	X39	X39
X10	X5.10	X19	X25	X30	X34	X36	X37	X40	X40
X11	X5.11	X20	X26	X31	X35	X37	X38	X41	X41
X12	X5.12	X21	X27	X32	X36	X38	X39	X42	X42
X13	X5.13	X22	X28	X33	X37	X39	X40	X43	X43
X14	X5.14	X23	X29	X34	X38	X40	X41	X44	X44
X15	X5.15	X24	X30	X35	X39	X41	X42	X45	X45
X16	X5.16	X25	X31	X36	X40	X42	X43	X46	X46
X17	X5.17	X26	X32	X37	X41	X43	X44	X47	X47
X18	X5.18	X27	X33	X38	X42	X44	X45	X48	X48
X19	X5.19	X28	X34	X39	X43	X45	X46	X49	X49
X20	X5.20	X29	X35	X40	X44	X46	X47	X50	X50
X21	X5.21	X30	X36	X41	X45	X47	X48	X51	X51
X22	X5.22	X31	X37	X42	X46	X48	X49	X52	X52
X23	X5.23	X32	X38	X43	X47	X49	X50	X53	X53
X24	X5.24	X33	X39	X44	X48	X50	X51	X54	X54
X25	X5.25	X34	X40	X45	X49	X51	X52	X55	X55
X26	X5.26	X35	X41	X46	X50	X52	X53	X56	X56
X27	X5.27	X36	X42	X47	X51	X53	X54	X57	X57
X28	X5.28	X37	X43	X48	X52	X54	X55	X58	X58
X29	X5.29	X38	X44	X49	X53	X55	X56	X59	X59
X30	X5.30	X39	X45	X50	X54	X56	X57	X60	X60
X31	X5.31	X40	X46	X51	X55	X57	X58	X61	X61
X32	X5.32	X41	X47	X52	X56	X58	X59	X62	X62
X33	X5.33	X42	X48	X53	X57	X59	X60	X63	X63
X34	X5.34	X43	X49	X54	X58	X60	X61	X64	X64
X35	X5.35	X44	X50	X55	X59	X61	X62	X65	X65
X36	X5.36	X45	X51	X56	X60	X62	X63	X66	X66
X37	X5.37	X46	X52	X57	X61	X63	X64	X67	X67
X38	X5.38	X47	X53	X58	X62	X64	X65	X68	X68
X39	X5.39	X48	X54	X59	X63	X65	X66	X69	X69
X40	X5.40	X49	X55	X60	X64	X66	X67	X70	X70
X41	X5.41	X50	X56	X61	X65	X67	X68	X71	X71
X42	X5.42	X51	X57	X62	X66	X68	X69	X72	X72
X43	X5.43	X52	X58	X63	X67	X69	X70	X73	X73
X44	X5.44	X53	X59	X64	X68	X70	X71	X74	X74
X45	X5.45	X54	X60	X65	X69	X71	X72	X75	X75
X46	X5.46	X55	X61	X66	X70	X72	X73	X76	X76
X47	X5.47	X56	X62	X67	X71	X73	X74	X77	X77
X48	X5.48	X57	X63	X68	X72	X74	X75	X78	X78
X49	X5.49	X58	X64	X69	X73	X75	X76	X79	X79
X50	X5.50	X59	X65	X70	X74	X76	X77	X80	X80
X51	X5.51	X60	X66	X71	X75	X77	X78	X81	X81
X52	X5.52	X61	X67	X72	X76	X78	X79	X82	X82
X53	X5.53	X62	X68	X73	X77	X79	X80	X83	X83
X54	X5.54	X63	X69	X74	X78	X80	X81	X84	X84
X55	X5.55	X64	X70	X75	X79	X81	X82	X85	X85
X56	X5.56	X65	X71	X76	X80	X82	X83	X86	X86
X57	X5.57	X66	X72	X77	X81	X83	X84	X87	X87
X58	X5.58	X67	X73	X78	X82	X84	X85	X88	X88
X59	X5.59	X68	X74	X79	X83	X85	X86	X89	X89
X60	X5.60	X69	X75	X80	X84	X86	X87	X90	X90
X61	X5.61	X70	X76	X81	X85	X87	X88	X91	X91
X62	X5.62	X71	X77	X82	X86	X88	X89	X92	X92
X63	X5.63	X72	X78	X83	X87	X89	X90	X93	X93
X64	X5.64	X73	X79	X84	X88	X90	X91	X94	X94
X65	X5.65	X74	X80	X85	X89	X91	X92	X95	X95
X66	X5.66	X75	X81	X86	X90	X92	X93	X96	X96
X67	X5.67	X76	X82	X87	X91	X93	X94	X97	X97
X68	X5.68	X77	X83	X88	X92	X94	X95	X98	X98
X69	X5.69	X78	X84	X89	X93	X95	X96	X99	X99
X70	X5.70	X79	X85	X90	X94	X96	X97	X100	X100
X71	X5.71	X80	X86	X91	X95	X97	X98	X101	X101
X72	X5.72	X81	X87	X92	X96	X98	X99	X102	X102
X73	X5.73	X82	X88	X93	X97	X99	X100	X103	X103
X74	X5.74	X83	X89	X94	X98	X100	X101	X104	X104
X75	X5.75	X84	X90	X95	X99	X101	X102	X105	X105
X76	X5.76	X85	X91	X96	X100	X102	X103	X106	X106
X77	X5.77	X86	X92	X97	X101	X103	X104	X107	X107
X78	X5.78	X87	X93	X98	X102	X104	X105	X108	X108
X79	X5.79	X88	X94	X99	X103	X105	X106	X109	X109
X80	X5.80	X89	X95	X100	X104	X106	X107	X110	X110
X81	X5.81	X90	X96	X101	X105	X107	X108	X111	X111
X82	X5.82	X91	X97	X102	X106	X108	X109	X112	X112
X83	X5.83	X92	X98	X103	X107	X109	X110	X113	X113
X84	X5.84	X93	X99	X104	X108	X110	X111	X114	X114
X85	X5.85	X94	X100	X105	X109	X111	X112	X115	X115
X86	X5.86	X95	X101	X106	X110	X112	X113	X116	X116
X87	X5.87	X96	X102	X107	X111	X113	X114	X117	X117
X88	X5.88	X97	X103	X108	X112	X114	X115	X118	X118
X89	X5.89	X98	X104	X109	X113	X115	X116	X119	X119
X90	X5.90	X99	X105	X110	X114	X116	X117	X120	X120
X91	X5.91	X100	X106	X111	X115	X117	X118	X121	X121
X92	X5.92	X101	X107	X112	X116	X118	X119	X122	X122
X93	X5.93	X102	X108	X113	X117	X119	X120	X123	X123
X94	X5.94	X103	X109	X114	X118	X120	X121	X124	X124
X95	X5.95	X104	X110	X115	X119	X121	X122	X125	X125
X96	X5.96	X105	X111	X116	X120	X122	X123	X126	X126
X97	X5.97	X106	X112	X117	X121	X123	X124	X127	X127
X98	X5.98	X107	X113	X118	X122	X124	X125	X128	X128
X99	X5.99	X108	X114	X119	X123	X125	X126	X129	X129
X100	X5.100	X109	X115	X120	X124	X126	X127	X130	X130
X101	X5.101	X110	X116	X121	X125	X127	X128	X131	X131
X102	X5.102	X111	X117	X122	X126	X128	X129	X132	X132
X103	X5.103	X112	X118	X123	X127	X129	X130	X133	X133
X104	X5.104	X113	X119	X124	X128	X130	X131	X134	X134
X105	X5.105	X114	X120	X125	X129	X131	X132	X135	X135
X106	X5.106	X115	X121	X126	X130	X132	X133	X136	X136
X107	X5.107	X116	X122	X127	X131	X133	X134	X137	X137
X108	X5.108	X117	X123	X128	X132	X134	X135	X138	X138
X109	X5.109	X118	X124	X129	X133	X135	X136	X139	X139
X110	X5.110	X119	X125	X130	X134	X136	X137	X140	X140
X111	X5.111	X120	X126	X131	X135	X137	X138	X141	X141
X112	X5.112	X121	X127	X132	X136	X138	X139	X142	X142
X113	X5.113	X122	X128	X133	X137	X139	X140	X143	X143
X114	X5.114	X123	X129	X134	X138	X140	X141	X144	X144
X115	X5.115	X124	X130	X135	X139	X141	X142	X145	X145
X116	X5.116	X125	X131	X136	X140	X142	X143	X146	X146
X117	X5.117	X126	X132	X137	X141	X143	X144	X147	X147
X118	X5.118	X127	X133	X138	X142	X144	X145	X148	X148
X119	X5.119	X128	X134	X139	X143	X145	X146	X149	X149
X120	X5.120	X129	X135	X140	X144	X146	X147	X150	X150
X121	X5.121	X130	X136	X141	X145	X147	X148	X151	X151
X122	X5.122	X131	X137	X142	X146	X148	X149	X152	X152
X123	X5.123	X132	X138	X143	X147	X149	X150	X153	X153
X124	X5.124	X133	X139	X144	X148	X150	X151	X154	X154
X125	X5.125	X134	X140	X145	X149				

## 8.2 THYRO-P 2P 2-PHASE POWER CONTROLLER

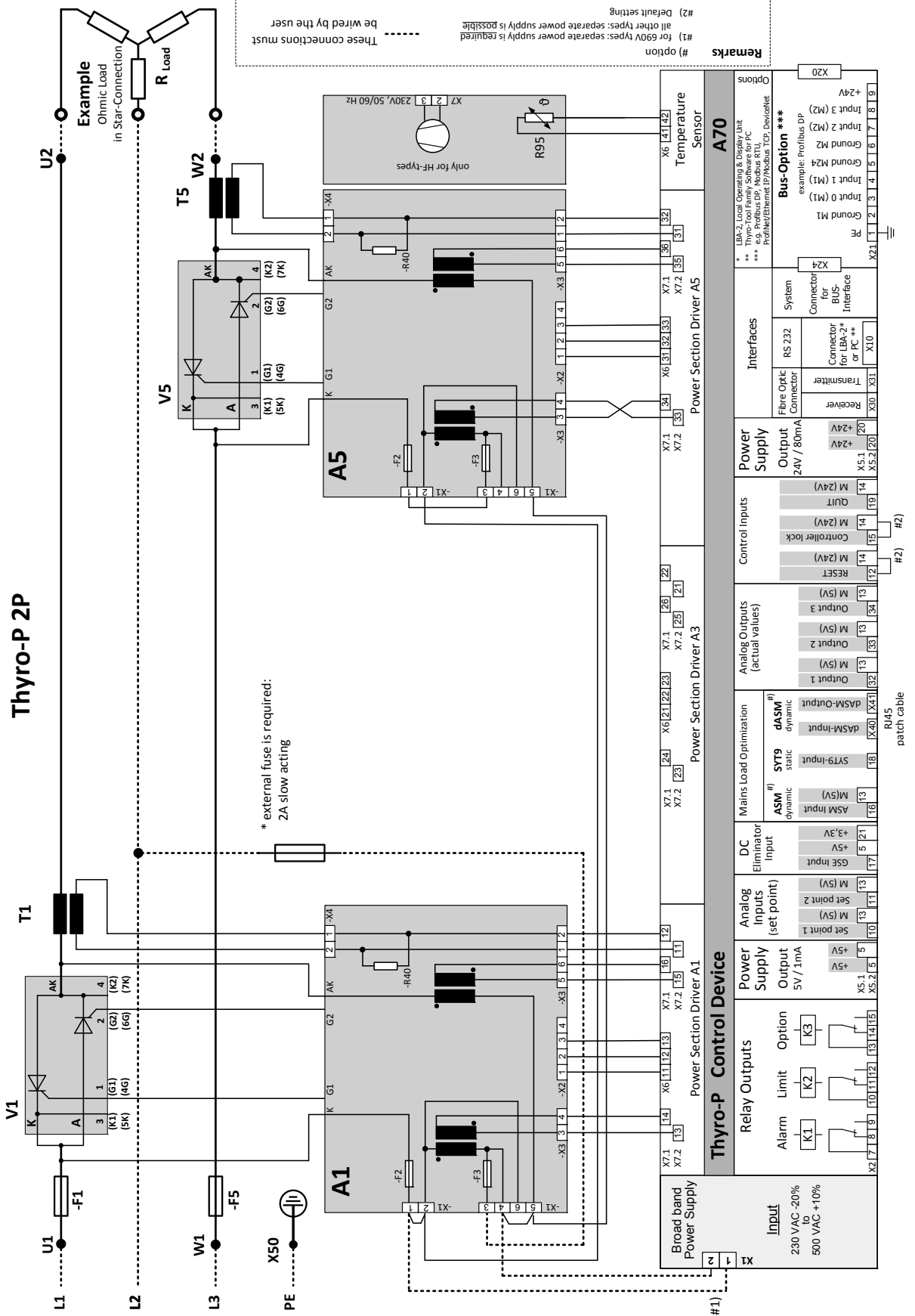

### 8.3 THYRO-P 3P 3-PHASE POWER CONTROLLER

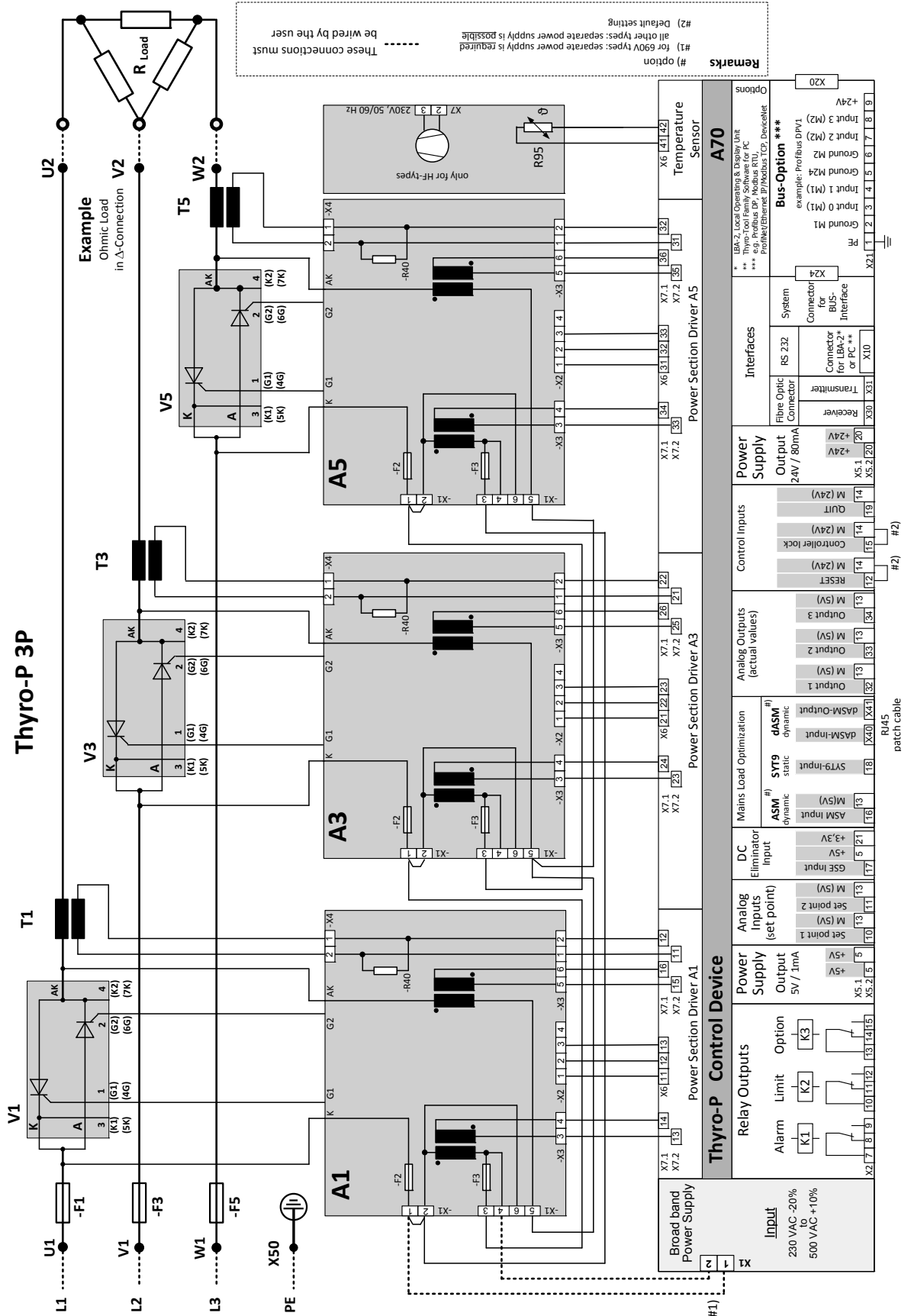

8.4 THYRO-P VSC 2 2-STEP PRIMARY VSC

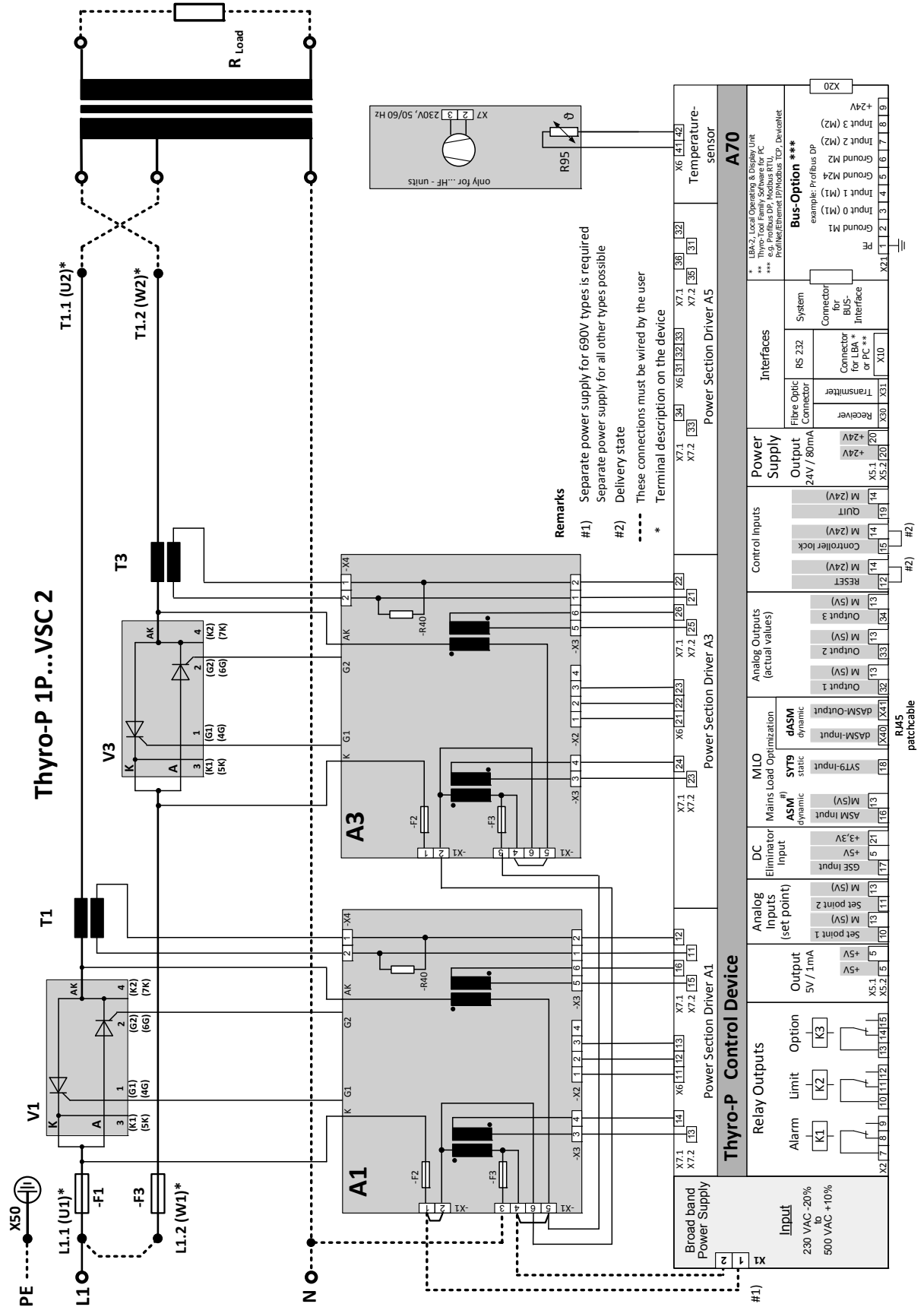

### 8.5 THYRO-P VSC 3 3-STEP PRIMARY VSC

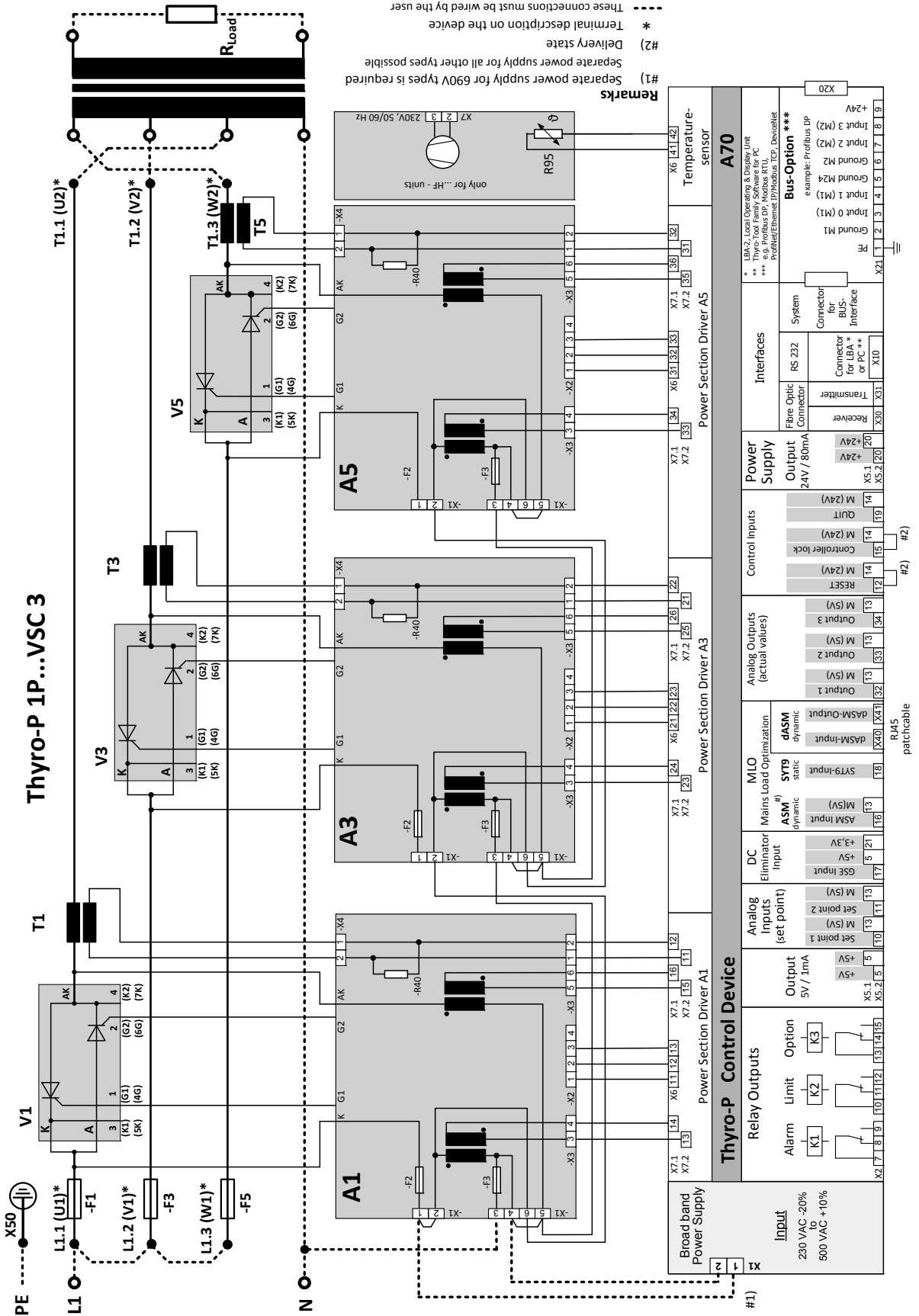

#1) Separate power supply for 690V types is required  
 #2) Delivery state  
 \* Terminal description on the device  
 --- These connections must be wired by the user

Thyro-P Control Device	
<b>Broad band Power Supply</b>	<b>Relay Outputs</b>
Input 230 VAC -20% 500 VAC +10%	Alarm Limit Option K1 K2 K3
Output 5V / 1mA +5V	X5.1 X5.2 X5.5 X9
Set point 1 M (5V)	X2.1 X2.2 X2.3 X2.4 X2.5 X2.6 X2.7 X2.8 X2.9 X2.10 X2.11 X2.12 X2.13 X2.14 X2.15
Set point 2 M (5V)	
Analog Inputs (set point)	
GSE input +3.3V	
ASM input M (5V)	
ASM dynamic static SVT9 input M (5V)	
DC Eliminator Input	
ASM dynamic static SVT9 input M (5V)	
MLO Mains Load Optimization	
dASM input M (5V)	
dASM output M (5V)	
Output 1 M (5V)	
Output 2 M (5V)	
Output 3 M (5V)	
Reset M (24V)	
Controller lock M (24V)	
QUIT M (24V)	
Power Supply Output 24V / 80mA	
Fibre Optic Connector Receiver X30 X31 X32 X33 X34 X35 X36 X37 X38 X39 X40 X41 X42 X43 X44 X45 X46 X47 X48 X49 X50 X51 X52 X53 X54 X55 X56 X57 X58 X59 X60 X61 X62 X63 X64 X65 X66 X67 X68 X69 X70 X71 X72 X73 X74 X75 X76 X77 X78 X79 X80 X81 X82 X83 X84 X85 X86 X87 X88 X89 X90 X91 X92 X93 X94 X95 X96 X97 X98 X99 X100	
System Connector for LBA <sup>*)</sup> or PC <sup>**)***</sup> Interface X10 X11 X12 X13 X14 X15 X16 X17 X18 X19 X20 X21 X22 X23 X24 X25 X26 X27 X28 X29 X30 X31 X32 X33 X34 X35 X36 X37 X38 X39 X40 X41 X42 X43 X44 X45 X46 X47 X48 X49 X50 X51 X52 X53 X54 X55 X56 X57 X58 X59 X60 X61 X62 X63 X64 X65 X66 X67 X68 X69 X70 X71 X72 X73 X74 X75 X76 X77 X78 X79 X80 X81 X82 X83 X84 X85 X86 X87 X88 X89 X90 X91 X92 X93 X94 X95 X96 X97 X98 X99 X100	
Temperature sensor R95	

\*) LBA=2, Local Operating & Display Unit  
 \*\*) Thyro-Tool Family Software for PC  
 \*\*\*) Profibus/Ethernet/RS485/Modbus (TCP) DeviceNet

Bus-Option  
 example: Profibus DP  
 Input 0 (M1)  
 Input 1 (M1)  
 Ground M2  
 Input 2 (M2)  
 Input 3 (M2)  
 +24V

Power Section Driver A1  
 Power Section Driver A3  
 Power Section Driver A5

Remarks  
 #1) Separate power supply for 690V types is required  
 #2) Delivery state  
 \* Terminal description on the device  
 --- These connections must be wired by the user

Thyro-P 1P...VSC 3

8.6 THYRO-P VSC THYRO-P VSC 2 2-STEP SECONDARY VSC

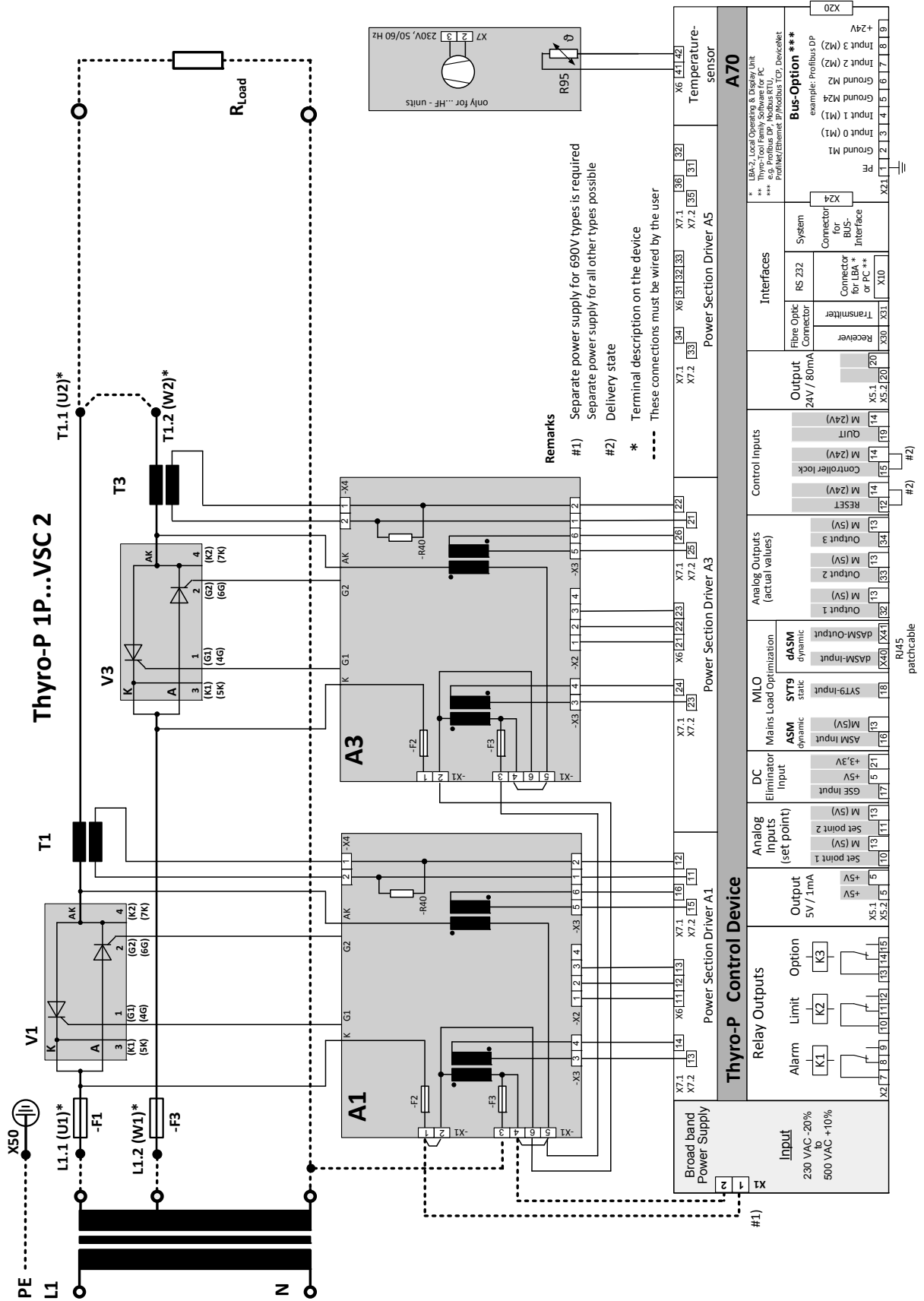

8.7 THYRO-P VSC 3 3-STEP SECONDARY VSC

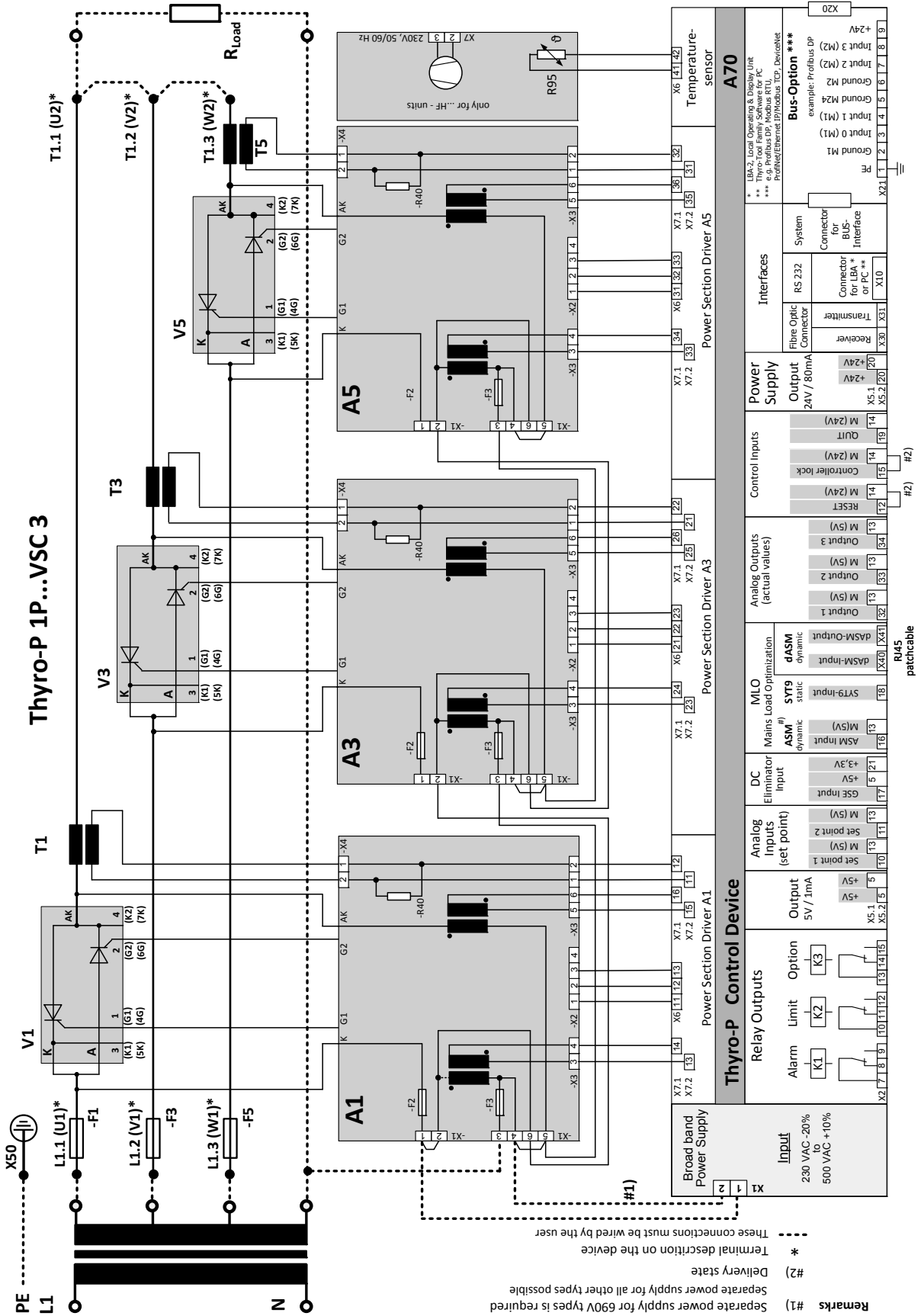

## 9. SPECIAL REMARKS

### 9.1 INSTALLATION

The installation orientation of Thyro-P is vertical, so that ventilation of the thyristors fastened to heat sinks is ensured. In case of cabinet mounting, additionally sufficient ventilation of the cabinet must be ensured. The distance between Power Controller and the bottom should be at least 100mm; the distance to the ceiling 150mm. The devices may be installed next to each other without lateral distance. Heating up of the device by heat sources must be avoided. The dissipation of the Power Controller is stated in the table chapter 10 TYPE OVERVIEW.

Grounding must be performed according to local regulations of the utility company (grounding screw for protective conductor connection).

### 9.2 PROTECTION AGAINST CONTACT IP20

#### ATTENTION

Energized parts.

The device shall immediately be disconnected from the power supply before installation. The Thyro-P is designed according to IP20 protection code.



#### CAUTION

To ensure protection during operation, the correct mounting is necessary of the added IP20 protection devices at each electric connection.

In the following description mounting of the protection devices is shown, this handling also applies to 2- or 3- phase units of Thyro-P.

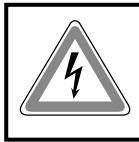

For devices of 16A/37A/75A/110A applies:

- The blind cover for non-used connections has to be pressed into the device cover until it snaps into place.
- For devices of 110A, the covers have to be adjusted by the customer in accordance to the needed gaps while IP20 protection code has to be considered. Therefore gaps have to be chosen as small as possible, so that needed IP20 protection code is ensured.

The cover has to be pressed into the device cover until it snaps into place.

For devices of 80A/130A/170A/200A/280A applies:

- The covers have to be adjusted by the customer in accordance to the needed gaps while IP20 protection code has to be considered. Therefore gaps have to be chosen as small as possible, so that needed IP20 protection code is ensured.
- Afterwards the blind cover for non-used connections has to be pressed into the device cover until it snaps into place.

For devices of 495A/650A applies:

Before connecting the device, the coverage has to be removed.

The connections coming from the customer side have to be connected to the copper bars of the device.

Please be consider that an adequate IP20 protection has to be secured.

Then the according coverages have to be fixed again on the device.

For devices of 1000A-1500A applies:

Before connecting the device, the coverage has to be removed.

The connections coming from the customer side have to be connected to the copper bars of the device.

Afterwards safe gaps (according to IP20) have to be cut into the covers.  
Please be consider that an adequate IP20 protection has to be secured.  
Then the according coverages have to be fixed again on the device.

### 9.3 COMMISSIONING

The device must be connected to the mains and the associated load according to the wiring diagrams.

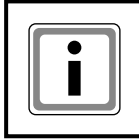

#### REMARK

If the units Thyro-P 1P (or Thyro-P 3P in „open delta“) and/or Thyro-P 2P are operated at over 600 V and without load at the output side, voltages can occur above input voltage at the connection points U2,V2 and W2. In this case, additional 690V snubber boards are to be used (see chapter 13 ACCESSORIES AND OPTIONS).

Depending on connection system of the load (star, delta, etc.), it must be ensured that the load voltage transformers in the power sections are wired correctly (terminal strip X1 of the power section). The correct terminals may be found in the connecting diagrams.

On delivery, the device is parameterized adjusted to the respective power section. The operating mode TAKT (Thyro-P 1P / Thyro-P 2P) is set. If a different operating mode is desired, then the user must set this using the LBA-2, PC, etc. Generally, the standard parameters (see menu list) should be reviewed and adjusted to the respective conditions for use by the user (for instance operating mode, control mode, limitations, monitoring, times, characteristics, actual value outputs, fault indications, relays, time and date, etc.).

Besides the load, some control signals must be connected as well (refer to chapter 4). The following signals are always required for operation of the device:

Set point	(terminal 10 or 11/or via interfaces)
RESET	(on ground, on terminal 12, jumper set as standard)
Regular inhibit	(on ground, on terminal 15, jumper set as standard)

If the RESET is not connected, then the device is in reset state and is not operating (LED „ON“ shows red light), i.e. no communications is possible via interface. Further details of the RESET are described in chapter 4.4. If the regulator inhibit is not connected, then the device is fully operable, but the power section is only controlled using the values of the minimal limitations (LED „PULSE LOCK“ is on). Further details on the regulator inhibit may be found in the chapter 4.5 of the same name.



#### ATTENTION

The controller lock may also be set via the interfaces!



#### ATTENTION

The control device is to be operated only with casing.

### 9.4 SERVICE

The devices delivered have been tested according to the state of the art and have been produced to a high quality standard (DIN EN ISO 9001). In the event of any faults or problems despite such controls, please contact our technical support team (see page 12 CONTACT).

### 9.5 CHECKLIST

No frontside LED is on:

- for 690V devices, the power supply for the control device A70 to be provided by the customer is missing. (Attention, maximum nominal input voltage 500V)

- check voltage at terminal X1.1 and X1.2 of the control device A70
- check semiconductor fuse and the fuses F2 and F3 on the controller card A1.



### CAUTION

In any case, set the device de-energized and check if it is de-energized  
Terminal X1.3 on the controller card A1 not connected.

- if the semiconductor fuse is defective, then the following parameters must be checked in case of transformer load for the operating modes TAKT and SSSD:  
phase angle of the first half-wave (phase angle 1) = 60 degrees;  
possibly optimize. Check for the model type 1P, 2P or 3P  
Menu: Parameters/Operating mode/Number of phases controlled 1 2 3)

#### No load current

- RESET X5.2.12 is not jumpered for X5.1.14 (LED ON lit in red)
- supply voltage of the control device outside of the tolerable range
- controller lock X5.2.15 is not jumpered for X5.1.14 (LED PULSE LOCK is on)
- no set point is set. Using the LBA-2, check the total set point (effective total), or measure set point on X5.2.10 and X5.2.11.
  - set points are not cleared
  - parameterization of the set point inputs 20mA, 5V, 10V, does not matched to output of the temperature controller
  - check jumper X221 and X222 for current and voltage range
  - parameters STA and STE of the control characteristic are wrong
  - parameter for linkage of the set points is not set to "ADD"
- parameters IEMA, UEMA, PMA are set too small
- controller parameters  $T_i$  and  $K_p$  are set too large.

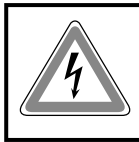

### CAUTION

Check fuses on the controller cards A1, A3, A5. In any case, set the device de-energized and check if it is de-energized.

- Load connection by the customer is missing (only for type 1P).  
Check connection on A1 terminal X1.3.
- Check synchronization voltage at the control device A70 at the terminal blocks X7.1 and X7.2.  
The thyristors are set to full scale
- Was the set point set via motor potentiometer function? Check value using the LBA-2.
- Check the control characteristic (Control start, Control end, Addition).
- Controller feedback signal available? Check current transformer and voltage transformer connections at the terminal blocks X7.1 and X7.2.
- Parameters Turn on-time  $T_{s\ min}$  and Back pulse limit position,  $U_{\ min}$ ,  $I_{\ min}$ ,  $P_{\ min}$  are larger than 0.
- Controller parameters  $T_i$  and  $K_p$  are set too small.
- Parameters  $I_{\ max}$ ,  $U_{\ max}$ ,  $P_{\ max}$  are set too large or the load current is too small.

#### Measures in case of other maloperation of the device:

- Evaluation of incident register (data logger) with LBA-2 or Thyro-Tool Family.
- Checking Thyro-P parameter.
- Checking wiring of Thyro-P.
- Correct number of controlled phases (parameters).
- With activated trouble signal relay Evaluation which faults led to a response, eliminate the fault.

## 10. TYPE OVERVIEW

### 10.1 TYPE RANGE 400 VOLT





TYPE VOLTAGE 230-400 VOLTS

TYPE (A)	CURRENT (A)	TYPE POWER (KVA)	DISSIPATION (W)	DIMENSIONS (MM)			WEIGHT (NET ABOUT KG)	DIM. DRAW. (NO.)	TEMP. CHARACTE- RISTIC (NO.)	CURRENT TRANSF. T1	BURDEN RESISTOR R40 (Ω)	SEMICON- DUCTOR FUSE* F1 (A)	UL 508
				W	H	D							
<b>THYRO-P 1P</b>													
	5 H	2	58	150	320	229	6	260	1	400/1	82.5	50	
	16 H	3.6	6	71	150	320	229	6	260	1	400/1	27.4	50
	25 H	10	83	150	320	229	6	260	1	400/1	15.4	50	
	37 H	8	15	105	150	320	229	6	260	1	100/1	2.70	50
	75 H	17	30	130	150	320	229	6	260	1	100/1	1.30	100
	110 H	25	44	175	150	320	229	6	260	2	100/1	0.91	180
	130 H	30	52	190	200	320	229	8	263	2	150/1	1.10	200
	170 H	39	68	220	200	320	229	8	266	2	200/1	1.10	315
	280 HF	64	112	365	200	370	229	9	265	2	300/1	1.00	350
	495 HF	114	198	595	175	412	340	15	266	3	500/1	1.00	630
	650 HF	149	260	750	175	412	340	15	266	3	700/1	1.00	900
	1000 HF	230	400	1450	242	762	505	35	268	4	1000/1	1.00	2x1000
	1500 HF	345	600	1775	242	762	505	35	285	5	1500/1	1.00	4x900
	2100 HF	483	840	2600	521	577	445	50	270	6	2000/1	0.91	4x1000
	2900 HF	667	1160	3400	603	577	470	62	271	7	3000/1	1.00	4x1500
<b>THYRO-P 2P</b>													
	16 H	6	11	107	225	320	229	10	272	1	400/1	27.4	50
	37 H	15	25	175	225	320	229	10	272	1	100/1	2.70	50
	75 H	30	52	220	225	320	229	10	272	1	100/1	1.30	100
	110 H	44	76	310	225	320	229	10	272	2	100/1	0.91	180
	130 H	52	90	350	325	320	229	12	275	2	150/1	1.10	200
	170 H	68	118	410	325	320	229	12	275	2	200/1	1.10	315
	280 HF	111	194	700	325	404	229	15	277	2	300/1	1.00	350
	495 HF	197	343	1150	261	502	340	22	278	3	500/1	1.00	630
	650 HF	259	450	1465	261	502	340	22	278	3	700/1	1.00	900
	1000 HF	398	693	2865	410	762	505	54	280	4	1000/1	1.00	2x1000
	1500 HF	597	1039	3510	410	762	505	54	280	5	1500/1	1.00	4x900
	2000 HF	1385	4800	526	837	445	84	282	6	2000/1	1.00	4x1000	
	2100 HF	796	4800	526	837	445	84	282	6	2000/1	1.00	4x1000	
	2750 HF	1905	6200	603	837	470	107	283	7	3000/1	1.00	4x1500	
	2900 HF	1905	6200	603	837	470	107	283	7	3000/1	1.00	4x1500	
<b>THYRO-P 3P</b>													
	16 H	6	11	228	300	320	229	14	284	1	400/1	27.4	50
	37 H	15	25	330	300	320	229	14	284	1	100/1	2.70	50
	75 H	30	52	400	300	320	229	14	284	1	100/1	1.30	100
	110 H	44	76	540	300	320	229	14	284	2	100/1	0.91	180
	130 H	52	90	560	450	320	229	17	287	2	150/1	1.10	200
	170 H	68	118	650	450	320	229	17	287	2	200/1	1.10	315
	280 HF	111	194	1070	450	404	229	20	289	2	300/1	1.00	350
	495 HF	197	343	1800	348	527	340	30	290	3	500/1	1.00	630
	650 HF	259	450	2265	348	527	340	30	290	3	700/1	1.00	900
	1000 HF	398	693	4370	575	762	505	74	292	4	1000/1	1.00	2x1000
	1500 HF	597	1039	5335	575	762	505	74	292	5	1500/1	1.00	4x900
	1850 HF	736	1281	6900	526	1094	445	119	294	6	2000/1	1.00	4x1000
	2600 HF	1035	1801	8700	603	1094	470	152	295	7	3000/1	1.10	4x1500



\* number of fuses per path of power section, built in

## 10.2 TYPE RANGE 500 VOLT



## TYPE VOLTAGE 500 VOLTS

TYPE (A)	CURRENT (KVA)	POWER (KVA)	DISSIPA- TION (W)	DIMENSIONS (MM)			WEIGHT (NET ABOUT KG)	DIM. DRAW. (NO.)	TEMP. CHARACTE- RISTIC (NO.)	CURRENT TRANSF. T1	BURDEN RESISTOR R40 (Ω)	SEMICON- DUCTOR FUSE* F1 (A)	
<b>THYRO-P 1P</b>													
5 H	2.5	58	150	320	229	6	260	1	400/1	82.5	50		
16 H	8	71	150	320	229	6	260	1	400/1	27.4	50		
25 H	12	83	150	320	229	6	260	1	400/1	15.4	50		
37 H	18	105	150	320	229	6	260	1	100/1	2.70	50		
75 H	38	130	150	320	229	6	260	1	100/1	1.30	100		
110 H	55	175	150	320	229	6	260	2	100/1	0.91	180		
130 H	65	190	200	320	229	8	263	2	150/1	1.10	200		
170 H	85	220	200	320	229	8	263	2	200/1	1.10	315		
280 HF	140	365	200	370	229	9	265	2	300/1	1.00	350		
495 HF	248	595	175	412	340	15	266	3	500/1	1.00	630		
650 HF	325	750	175	412	340	15	266	3	700/1	1.00	900		
1000 HF	500	1450	242	762	505	35	268	4	1000/1	1.00	2x1000		
1500 HF	750	1775	242	762	505	35	268	5	1500/1	1.00	4x900		
2100 HF	1050	2600	521	577	445	50	270	6	2000/1	0.91	4x1000		
2900 HF	1450	3400	603	577	470	62	271	7	3000/1	1.00	4x1500		

## THYRO-P 2P

16 H	14	107	225	320	229	10	272	1	400/1	27.4	50	
37 H	32	175	225	320	229	10	272	1	100/1	2.70	50	
75 H	65	220	225	320	229	10	272	1	100/1	1.30	100	
110 H	95	310	225	320	229	10	272	2	100/1	0.91	180	
130 H	112	350	325	320	229	12	275	2	150/1	1.10	200	
170 H	147	410	325	320	229	12	275	2	200/1	1.10	315	
280 HF	242	700	325	404	229	15	277	2	300/1	1.00	350	
495 HF	429	1150	261	502	340	22	278	3	500/1	1.00	630	
650 HF	563	1465	261	502	340	22	278	3	700/1	1.00	900	
1000 HF	866	2865	410	762	505	54	280	4	1000/1	1.00	2x1000	
1500 HF	1300	3510	410	762	505	54	280	5	1500/1	1.00	4x900	
2000 HF	1732	4800	526	837	445	84	282	6	2000/1	1.00	4x1000	
2750 HF	2381	6200	603	837	470	107	283	7	3000/1	1.00	4x1500	

## THYRO-P 3P

16 H	14	228	300	320	229	14	284	1	400/1	27.4	50	
37 H	32	330	300	320	229	14	284	1	100/1	2.70	50	
75 H	65	400	300	320	229	14	284	1	100/1	1.30	100	
110 H	95	540	300	320	229	14	284	2	100/1	0.91	180	
130 H	112	560	450	320	229	17	287	2	150/1	1.10	200	
170 H	147	650	450	320	229	17	287	2	200/1	1.10	315	
280 HF	242	1070	450	404	229	20	289	2	300/1	1.00	350	
495 HF	429	1800	348	527	340	30	290	3	500/1	1.00	630	
650 HF	563	2265	348	527	340	30	290	3	700/1	1.00	900	
1000 HF	866	4370	575	762	505	74	292	4	1000/1	1.00	2x1000	
1500 HF	1300	5335	575	762	505	74	292	5	1500/1	1.00	4x900	
1850 HF	1602	6900	526	1094	445	119	294	6	2000/1	1.00	4x1000	
2600 HF	2251	8700	603	1094	470	152	295	7	3000/1	1.10	4x1500	

\* number of fuses per path of power section, built in

## TYPE VOLTAGE 500 VOLTS

TYPE (A)	CURRENT (A)	TYPE POWER (KVA)	DISSIPATION (W)	DIMENSIONS (MM)			WEIGHT (NET ABOUT KG)	DIM. DRAW. (NO.)	TEMP. CHARACTE- RISTIC (NO.)	CURRENT TRANSF. T1	BURDEN RESISTOR R40 (Ω)	SEMICON- DUCTOR FUSE* F1 (A)
				W	H	D						
<b>THYRO-P 1P...VSC2</b>												
16 H	8	8	70	225	320	229	10	272	1	100/1	2.70	40
37 H	18	18	105	225	320	229	10		1	100/1	2.70	50
75 H	38	38	130	225	320	229	10		1	100/1	1.30	100
110 H	55	55	175	225	320	229	10		2	100/1	0.91	180
130 H	65	65	190	325	320	229	12	275	2	150/1	1.10	200
170 H	85	85	220	325	320	229	12		2	200/1	1.10	315
280 HF	140	140	365	325	397	229	15	277	2	300/1	1.00	350
495 HF	248	248	595	261	414	340	22	278	3	500/1	1.00	630
650 HF	325	325	750	261	414	340	22		3	700/1	1.00	900
1000 HF	500	500	1450	410	685	505	54	280	4	1000/1	1.00	2 x 1000
1500 HF	750	750	1775	410	685	505	54		5	1500/1	1.00	4 x 900
2000 HF	1050	1050	2600	526	837	445	84	282	6	2000/1	0.91	4 x 1000
2750 HF	1450	1450	3400	603	837	470	107	283	7	3000/1	1.00	4 x 1500









## THYRO-P 1P...VSC3

16 H	8	8	70	300	320	229	14	284	1	100/1	2.7	40
37 H	18	18	105	300	320	229	14		1	100/1	2.7	50
75 H	38	38	130	300	320	229	14		1	100/1	1.3	100
110 H	55	55	175	300	320	229	14		2	100/1	0.91	180
130 H	65	65	190	450	320	229	17	287	2	150/1	1.1	200
170 H	85	85	220	450	320	229	17		2	200/1	1.1	315
280 HF	140	140	365	450	397	229	20	289	2	300/1	1	350
495 HF	248	248	595	348	430	340	30	290	3	500/1	1	630
650 HF	325	325	750	348	430	340	30		3	700/1	1	900
1000 HF	500	500	1450	575	685	505	74	292	4	1000/1	1	2 x 1000
1500 HF	750	750	1775	575	685	505	74		5	1500/1	1	4 x 900
1850 HF	1050	1050	2600	526	1094	445	119	294	6	2000/1	0.91	4 x 1000
2600 HF	1450	1450	3400	603	1094	470	152	295	7	3000/1	1	4 x 1500









\* number of fuses per path of power section, built in

## 10.3 TYPE RANGE 690 VOLT









## TYPE VOLTAGE 690 VOLTS

TYPE (A)	CURRENT (KVA)	POWER (KVA)	DISSIPA- TION (W)	DIMENSIONS (MM)			WEIGHT (NET ABOUT KG)	DIM. DRAW. (NO.)	TEMP. CHARACTE- RISTIC (NO.)	CURRENT TRANSF. T1	BURDEN RESISTOR R40 (Ω)	SEMICON- DUCTOR FUSE* F1 (A)	
				W	H	D							
<b>THYRO-P 1P</b>													
80 H	55	125	200	320	229	8	263	1	100/1	1.20	100		
200 HF	138	260	200	370	229	9	265	2	200/1	1.00	250		
300 HF	207	360	175	412	340	15	266	3	300/1	1.00	350		
500 HF	345	625	175	412	340	15	266	3	500/1	1.00	630		
780 HF	538	910	242	762	505	35	268	4	1000/1	1.20	2x630		
1400 HF	966	1900	242	762	505	35	268	5	1500/1	1.00	4x700		
2000 HF	1380	3200	521	577	445	62	270	6	2000/1	1.00	4x900		
2600 HF	1794	3450	603	577	470	62	271	7	3000/1	1.10	4x1400		









## THYRO-P 2P

80 H	35	225	325	320	229	12	275	1	100/1	1.20	100	
200 HF	239	485	325	404	229	15	277	2	200/1	1.00	250	
300 HF	358	640	261	502	340	22	278	3	300/1	1.00	350	
500 HF	597	1225	261	502	340	22	278	3	500/1	1.00	630	
780 HF	932	1700	410	762	505	54	280	4	1000/1	1.20	2x630	
1400 HF	1673	3750	410	762	505	54	280	5	1500/1	1.00	4x700	
1850 HF	2210	5700	526	837	445	84	282	6	2000/1	1.00	4x900	
2400 HF	2868	6400	603	837	470	107	283	7	3000/1	1.20	4x1400	









## THYRO-P 3P

80 H	95	350	450	320	229	17	287	1	100/1	1.20	100	
200 HF	239	740	450	404	229	20	289	2	200/1	1.00	250	
300 HF	358	1020	348	527	340	30	290	3	300/1	1.00	350	
500 HF	597	1825	348	527	340	30	290	3	500/1	1.00	630	
780 HF	932	2740	575	762	505	74	292	4	1000/1	1.20	2x630	
1400 HF	1673	5600	575	762	505	74	292	5	1500/1	1.00	4x700	
1700 HF	2031	8000	526	1094	445	119	294	6	2000/1	1.10	4x900	
2200 HF	2619	9000	603	1094	470	152	295	7	3000/1	1.30	4x1400	

## THYRO-P 1P...VSC2

80 H	55	125	325	320	229	12	275	1	100/1	1.2	100	
200 HF	138	260	325	397	229	15	277	2	200/1	1	250	
300 HF	207	360	261	414	340	22	278	3	300/1	1	350	
500 HF	345	625	261	414	340	22		3	500/1	1	630	
780 HF	538	910	410	685	505	54	280	4	1000/1	1.2	2 x 630	
1400 HF	966	1900	410	685	505	54		5	1500/1	1	4 x 700	
1850 HF	1380	3200	526	837	445	84	282	6	2000/1	1	4 x 900	
2400 HF	1794	3450	603	837	470	107	283	7	3000/1	1.1	4 x 1400	

## THYRO-P 1P...VSC3

80 H	55	125	450	320	229	17	287	1	100/1	1.2	100	
200 HF	138	260	450	397	229	20	289	2	200/1	1	250	
300 HF	207	360	348	430	340	30	290	3	300/1	1	350	
500 HF	345	625	348	430	340	30		3	500/1	1	630	
780 HF	538	910	575	685	505	74	292	4	1000/1	1.2	2 x 630	
1400 HF	966	1900	575	685	505	74		5	1500/1	1	4 x 700	
1700 HF	1380	3200	526	1094	445	119	294	6	2000/1	1	4 x 900	
2200 HF	1794	3450	603	1094	470	152	295	7	3000/1	1.1	4 x 1400	

\* number of fuses per path of power section, built in

## 11. TECHNICAL DATA

TYPE VOLTAGE	...P400...	230 volts -20%	to	400 volts +10%
	...P500...	230 volts -20%	to	500 volts +10%
	...P690...	500 volts -20%	to	690 volts +10%
MAINS FREQUENCY	all models	45Hz	to	65Hz
LOAD DESCRIPTION	ohmic load (minimum 100W) ohmic load $R_{hot}/R_{cold}$ ratio up to 20 (MOSI operation) transformer load			
TRANSFORMER	The induction of the load side transformer should not exceed 1.45T in case of mains overvoltage when using grain-oriented, cold-rolled plates. This corresponds to a nominal induction of approx. 1.3T.			
OPERATING MODES	<p>TAKT = full oscillation clock = default setting for the models 1P, 2P and 3P</p> <p>VAR = phase-angle firing = only for the models 1P and 3P</p> <p>SSSD = soft-start-soft-down; a combination of „VAR“ and „TAKT“, for the models 1P, 2P and 3P, i.e. reduced mains surge load</p> <p>VSC_VAR = phase-angle firing in voltage sequence control</p>			
SET POINT INPUTS	<p>The power controller Thyro-P has 4 set point inputs. The set point inputs are indirectly connected to the mains (SELV, PELV).</p> <p>Set points 1, 2: external set point input signal ranges:</p> <p>0(4) - 20 mA    <math>R_i = \text{ca. } 250 \Omega / \text{max. } 24\text{mA}^*</math></p> <p>0 - 5 V        <math>R_i = \text{ca. } 8,8 \text{ k}\Omega / \text{max. } 12\text{V}</math></p> <p>0 - 10 V       <math>R_i = \text{ca. } 5 \text{ k}\Omega / \text{max. } 12\text{V}</math></p> <p>* refer to "ATTENTION" in chapter 2.2</p> <p>Set point 3: connection for fiber optic (LL) from the superordinate PC or automation system</p> <p>Set point 4: set point assignment via RS232 (for instance LBA-2)</p>			
ANALOG OUTPUTS	3 outputs: signal level 0-10 V, 0-20mA or 4-20mA. The maximum burden voltage is 10V			
CONTROL CHARACTERISTIC	<p>The control characteristic is established by the maximum value of the dimensions to be controlled and the key values of the set point. Using these key values, the linear control characteristic may be set at will.</p> <p>Every controller (for instance temperature controller), whose output signal is in the range of 0-20mA/0-5V/0-10V may be easily adapted to the power controller.</p>			
CONTROL TYPES	<p>Voltage control <math>U_{rms}</math></p> <p>Voltage control <math>U_{rms}^2 = \text{default setting}</math></p> <p>Current control <math>I_{rms}</math></p> <p>Current control <math>I_{rms}^2</math></p>			

	Power control P Without control
PRECISION	U-control: Better than $\pm 0.5\%$ I-Control: $\pm 0,5\%$ P-Control: $\pm 1\%$ All specifications are relating to the respective final value.
LIMITATIONS	Voltage limitation $U_{rms}$ Current limitation $I_{rms}$ = default setting Effective power limitation P Peak current limitation, MOSI operation
	Upon reaching one of these limits, the LED "Limit" on the front panel of Thyro-P is on and the relay K2 is activated. (terminal strip X2, terminals 10/11/12)
Relay K1, K2, K3	Contact load: AC max: 250V/6A (1500VA) AC min: >10VA; DC max: 300V/0.25A (62.5W) DC min : 5V/20mA contactor material: AgCdO
WITH UL APPLICATIONS	AC max: 250V/4A
AMBIENT TEMPERATURE	35°C external cooling (F models) 45°C self-air cooling At higher temperatures it is possible to operate with reduced type current:

COOLANT TEMPERATURE [°C]	$I/I_{RATED CURRENT}$	
	FORCED COOLING (VENTILATOR TYPES)	SELF COOLING
-10 bis 25	1.10	1.10
30	1.05	1.10
35	1.00	1.10
40	0.96	1.05
45	0.91	1.00
50	0.87	0.95
55	0.81	0.88

WITH UL APPLICATIONS UP TO +40°C

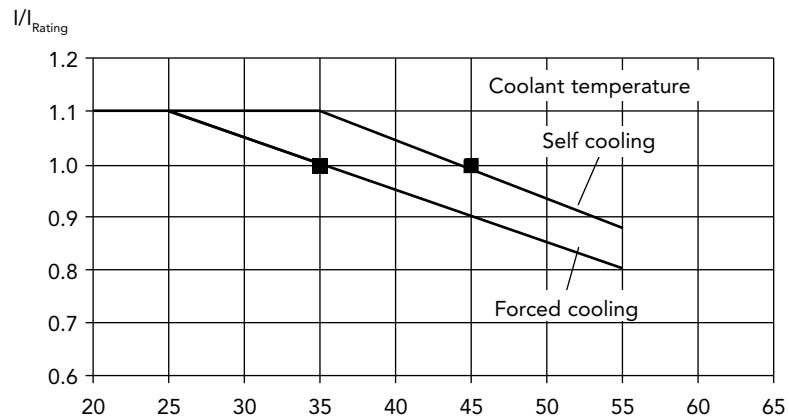

TABLE TERMINAL SCREWS	THYRO-P 1P, 2P, 3P	CONNECTOR	EARTHING SCREW
			U1, V1, W1, U2, V2, W2
	37H, 75H	M 6	M 6
	80H	M 8	M 10
	110H	M 6	M 6
	130H, 170H	M 8	M 10
	200HF, 280HF, 300HF	M 10	M 10
	495HF, 500HF, 650HF		
	780HF, 1000HF, 1400HF, 1500HF, 1700HF, 1850HF, 2000HF, 2100HF, 2200HF, 2400HF, 2600HF, 2750HF, 2900HF	M 12	M 12

WITH UL APPLICATIONS	POWER CONNECTION	USE ONLY 60°/75°C COPPER CONDUCTORS (UL SPECIFICATION)		
----------------------	------------------	--	--	--

STUD TORQUE FOR TABLE TERMINAL SCREWS [Nm]	SCREW	MIN	RATED	MAX
	M 2	0.2	0.25	0.3
M 6	3.0	4.4	5.9	
M 8	11.5	17.0	22.5	
M 10	22.0	33.0	44	
M 12	38.0	56.0	75	

[Pound inches]	SCREW	MIN	RATED	MAX
	M 2	1.9	2.2	2.5
M 6	26.1	38.9	52.2	
M 8	101.8	150.5	199.1	
M 10	194.7	292.1	389.4	
M 12	336.3	495.6	663.8	

FAN 230 V 50-60 HZ	THYRO-P (HF-TYPES)	TYPE CURRENT		AIR VOLUME [m <sup>3</sup> /h]	SOUND PRESS. IN 1 m DIST. [ca. dbA]
		50HZ I [A]	60HZ I [A]		
	<b>1P</b>				
	200HF, 280HF	0.22	0.22	120	53
	300HF, 495HF, 500HF, 650HF	0.50	0.38	150	67
	780HF, 1000HF, 1400HF, 1500HF	0.55	0.60	580	75
	2000HF, 2100HF, 2600HF, 2900HF	1.00	1.20	2200	81
	<b>2P / 1P...VSC 2</b>				
	200HF, 280HF	0.50	0.38	200	67
	300HF, 495HF, 500HF, 650HF	0.50	0.38	230	67
	780HF, 1000HF, 1400HF, 1500HF	1.00	1.20	1200	81
	1850HF, 2000HF, 2400HF, 2750HF	1.00	1.20	2100	81
	<b>3P / 1P...VSC 3</b>				
	200HF, 280HF	0.50	0.38	260	67
	300HF, 495HF, 500HF, 650HF	1.20	0.85	450	72
	780HF, 1000HF, 1400HF, 1500HF	1.00	1.20	1600	81
	1700HF, 1850HF, 2200HF, 2600HF	1.00	1.20	2000	81

Fans (for HF types) must be running when Thyro-P is operating. Connection according to connecting diagrams in chapter 8.

When operating conditions are below +10°C, a longer start-up time of the fan has to be considered. Therefore the adjustable range should amount at least double of the specified continuous current.

**REMARK**

In general the fan is subject to abrasion, therefore fan typical actions are recommended to check the fan on regular basis (scheduled maintenance), including testing of propeller on abrasion / deposition / corrosion and abnormal operating noise.

The used fans are quality products and have a life time of  $L_{10}=37500$  h. Depending on working conditions, it is recommended to change them after approx. 5 years.

## 12. DIMENSIONAL DRAWINGS

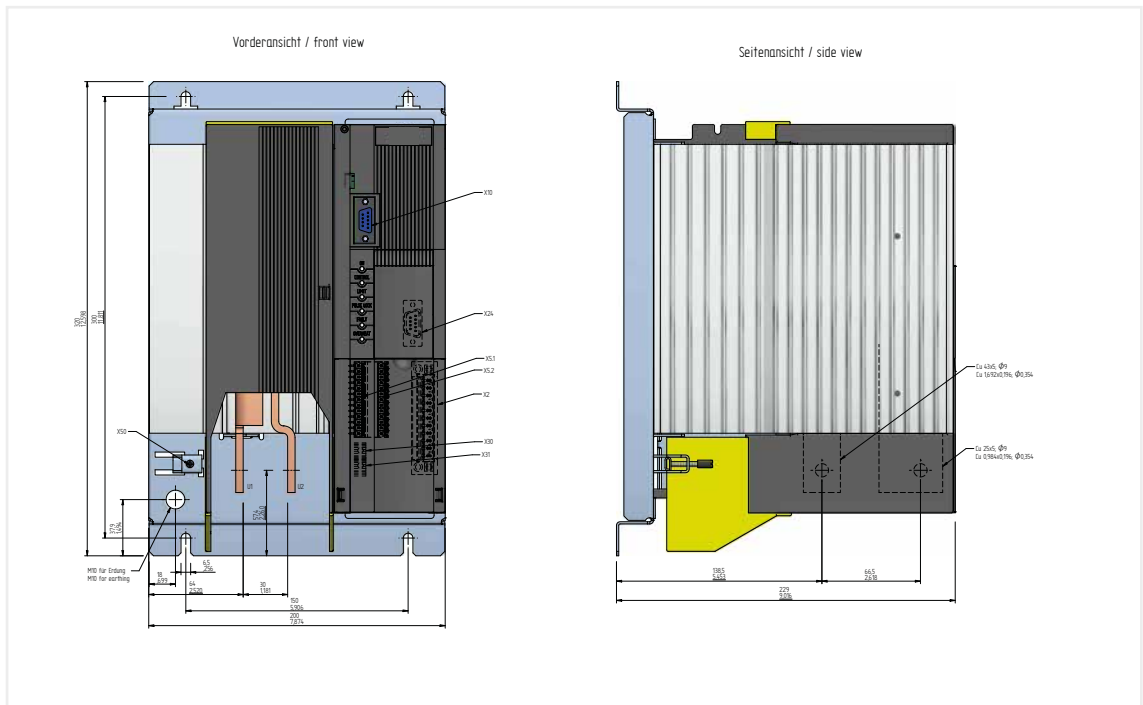
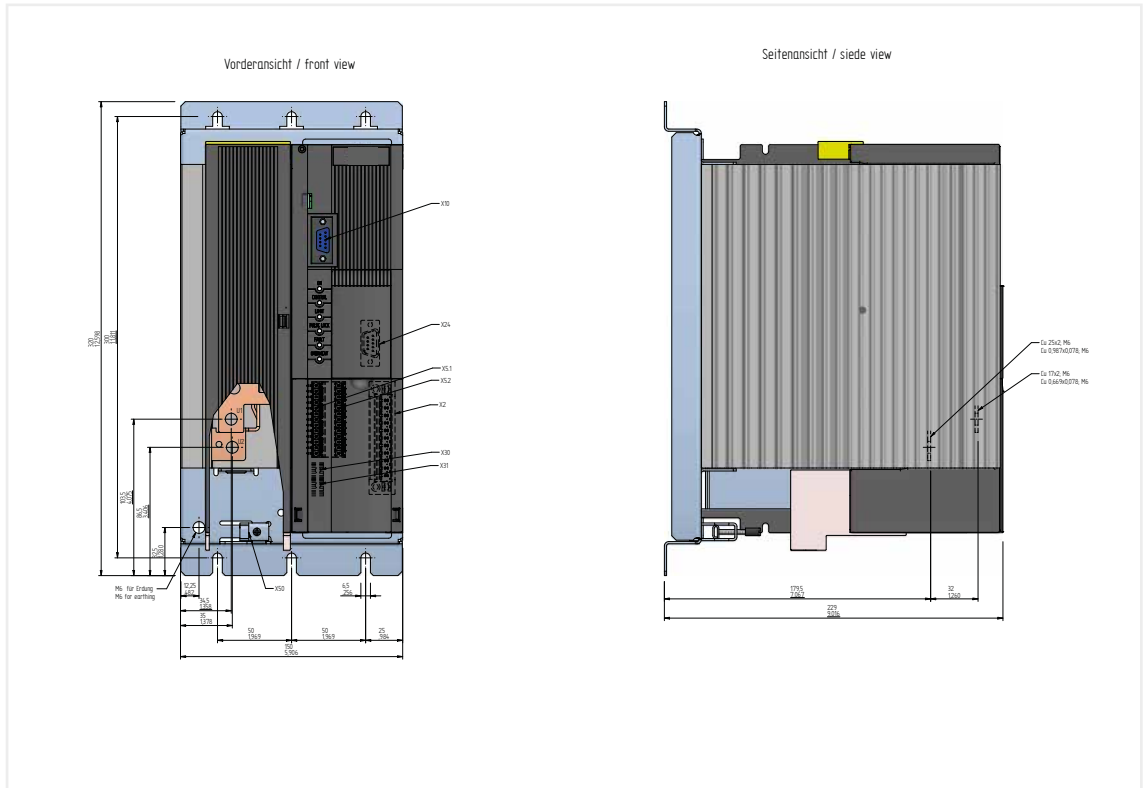

Thyro-P 1P (80 H, 130 H, 170 H)

Dimensional Drawing 263

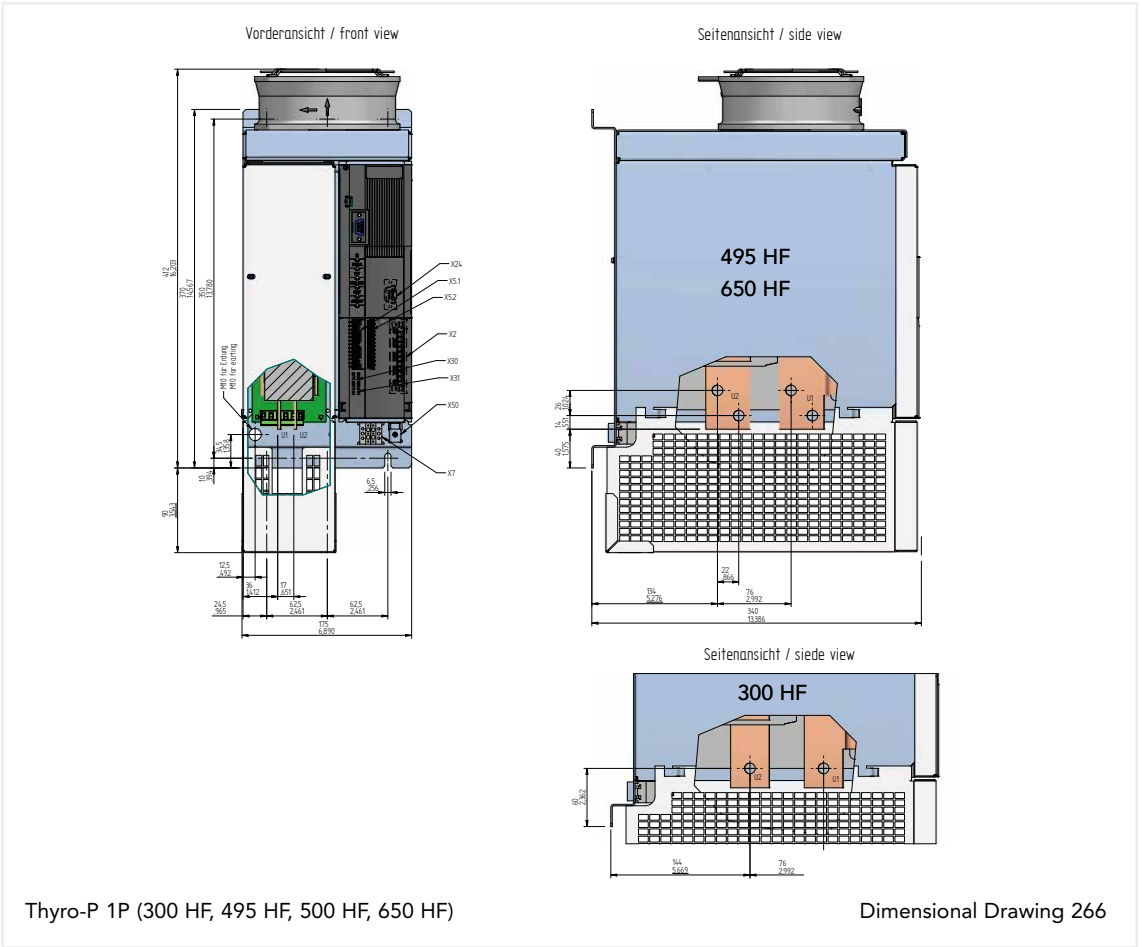
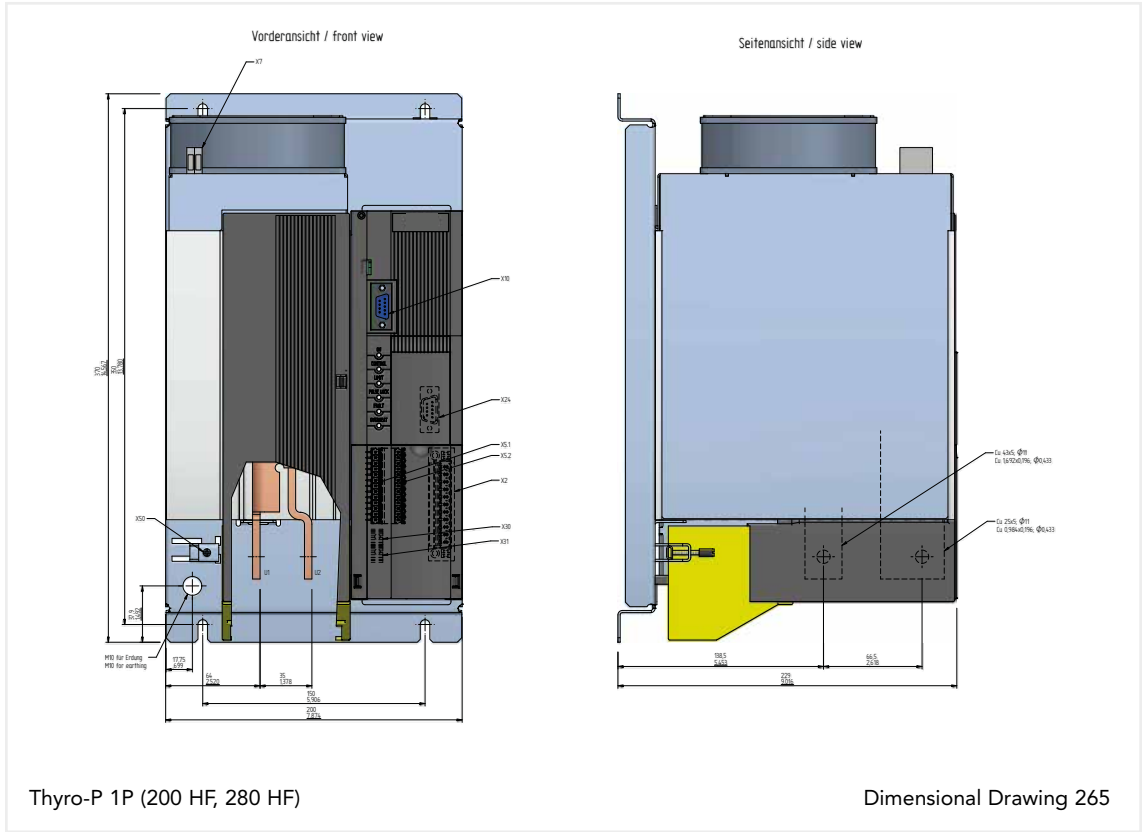





Vorderansicht / front view

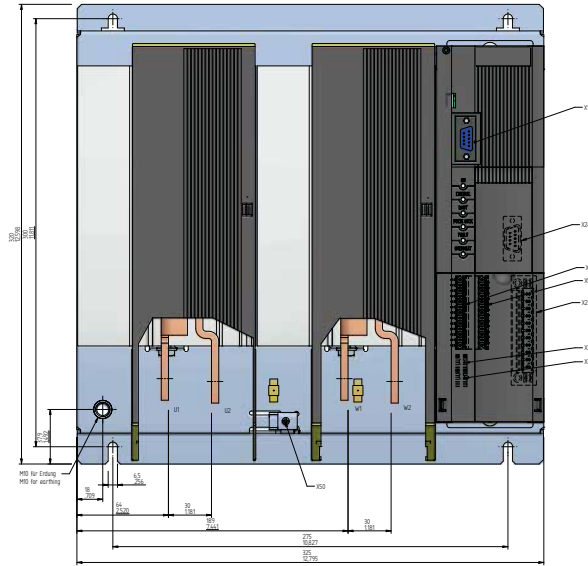

Seitenansicht / side view

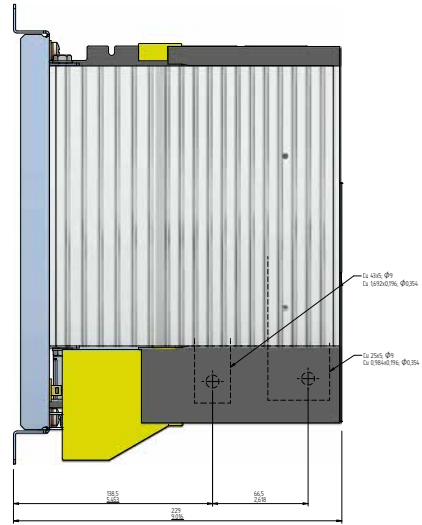

Thyro-P 2P (80 H, 130 H, 170 H)

Dimensional Drawing 275

Vorderansicht / front view

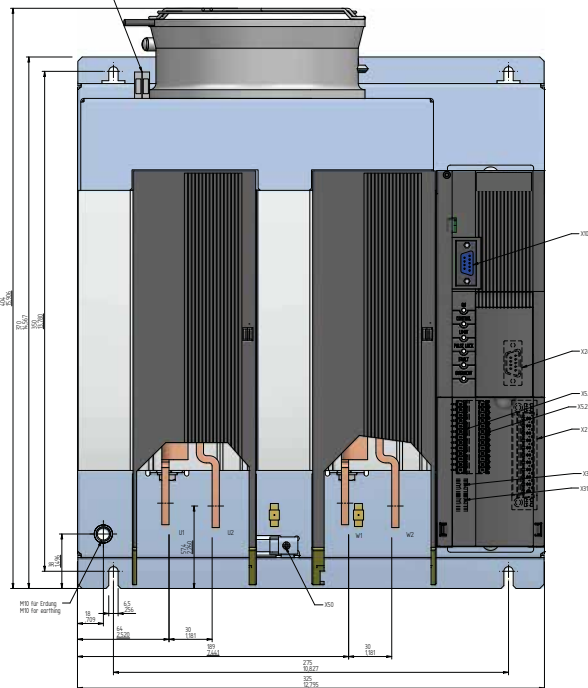

Seitenansicht / side view

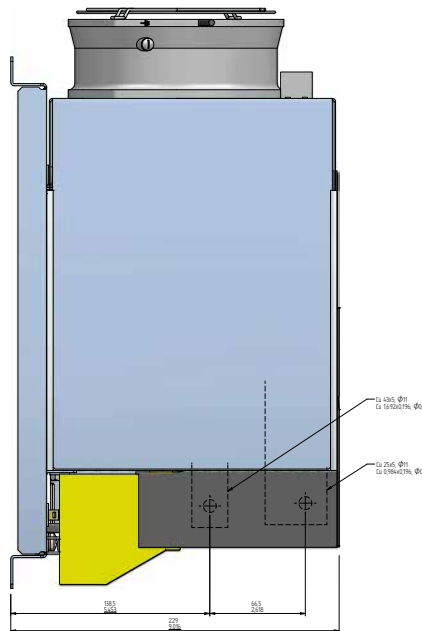

Thyro-P 2P (200 HF, 280 HF)

Dimensional Drawing 277





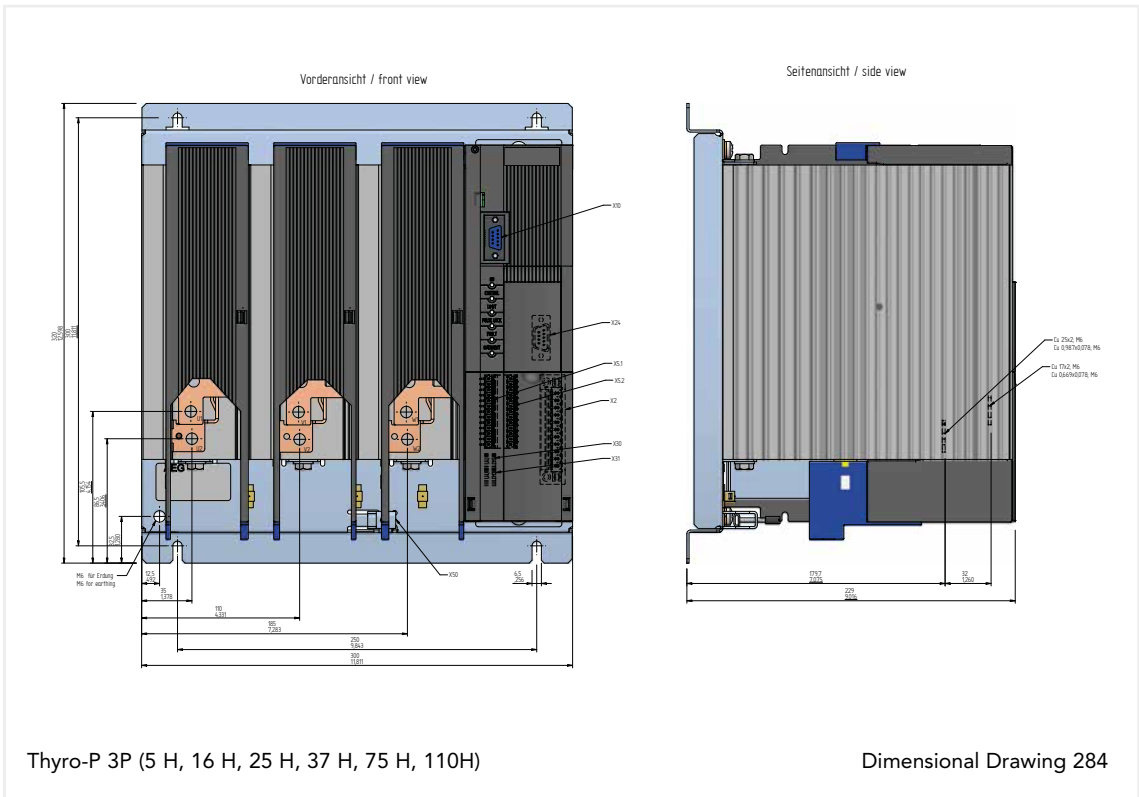
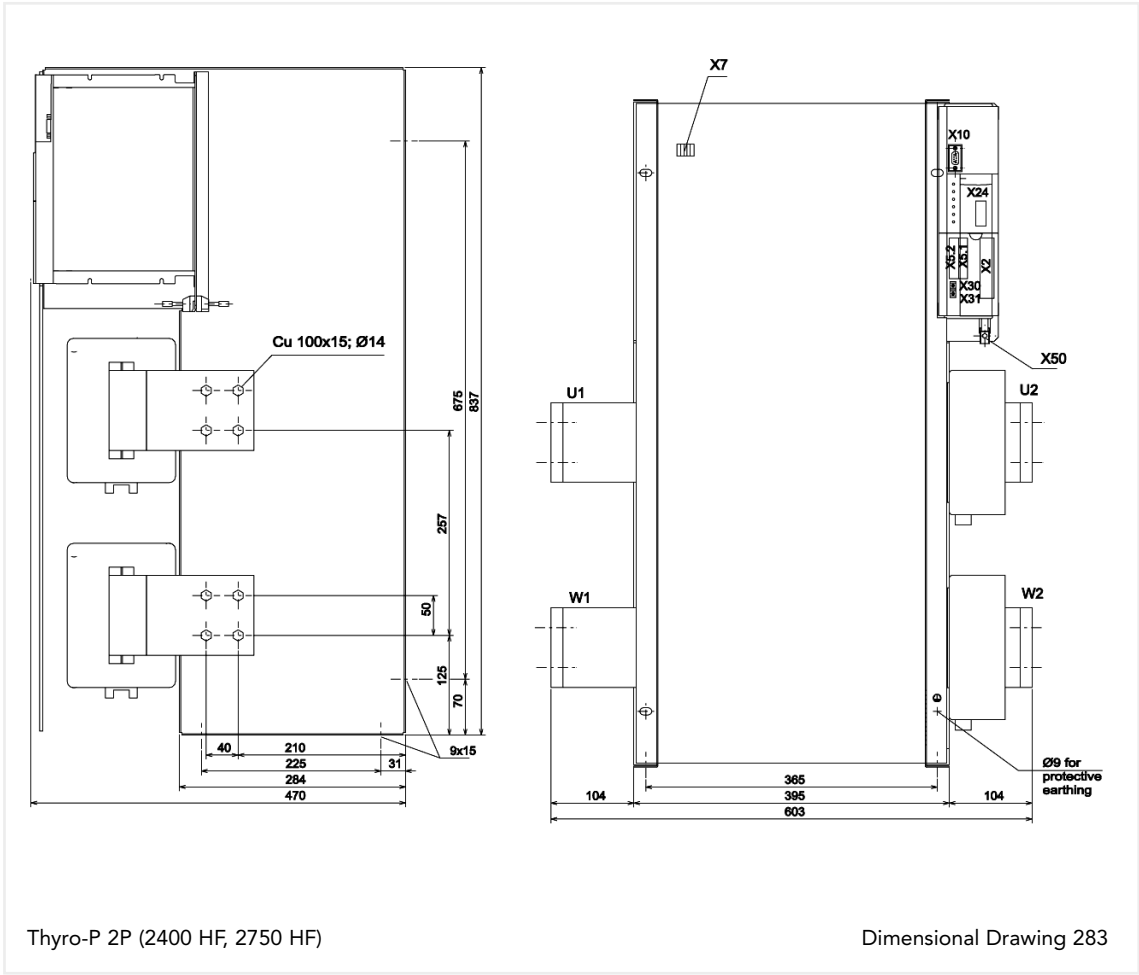

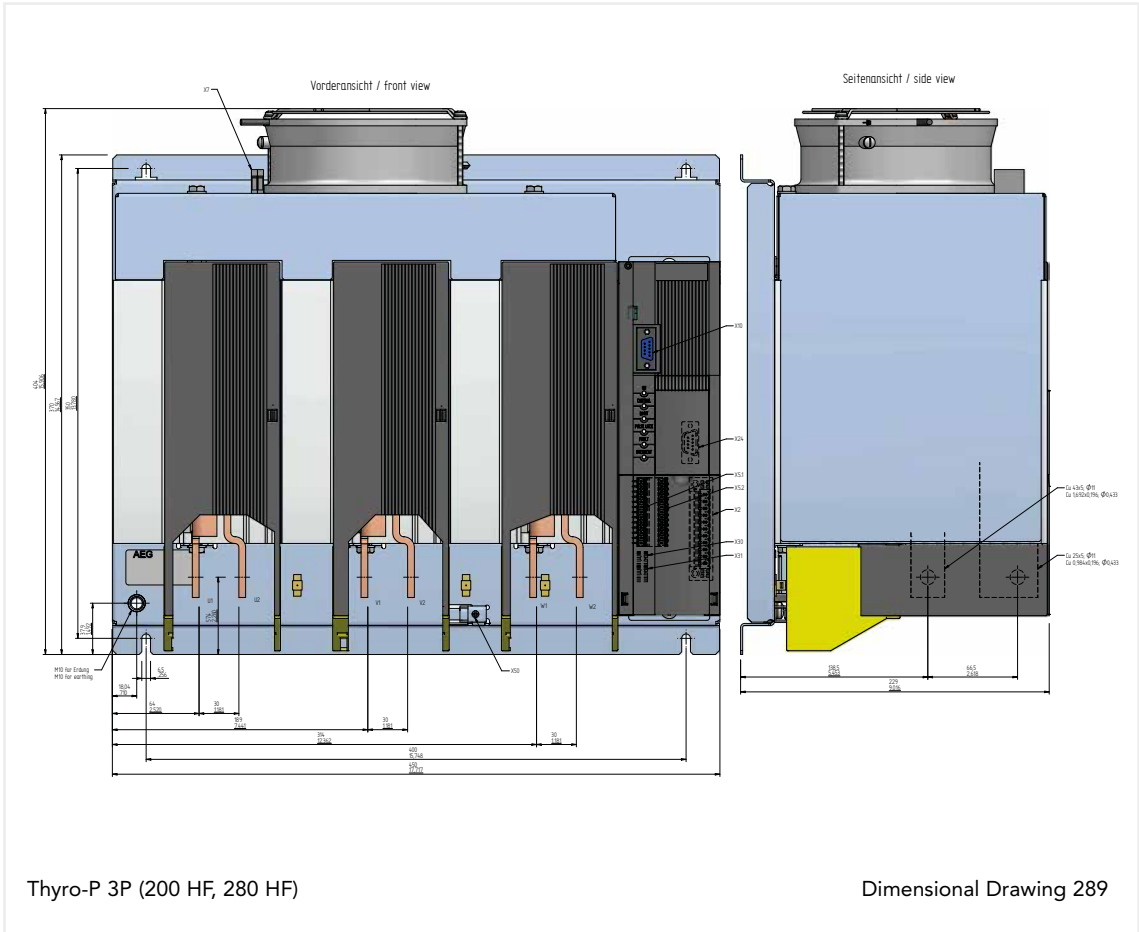
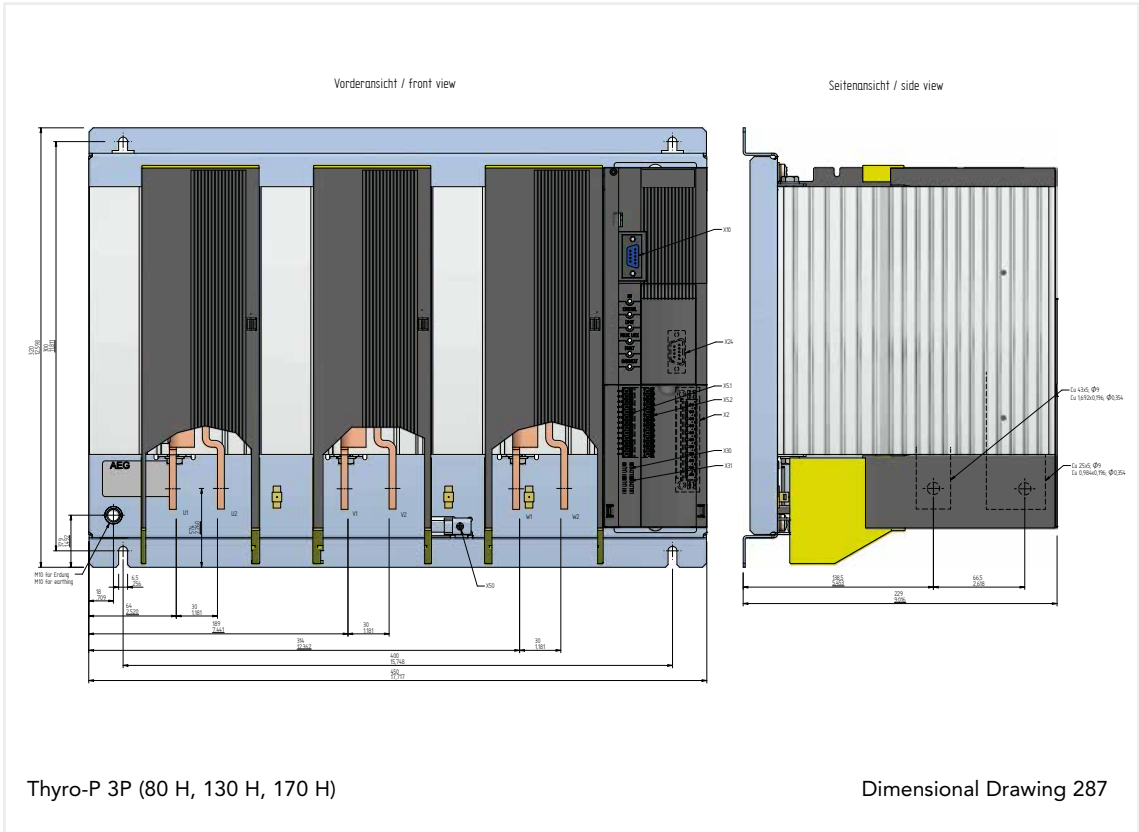

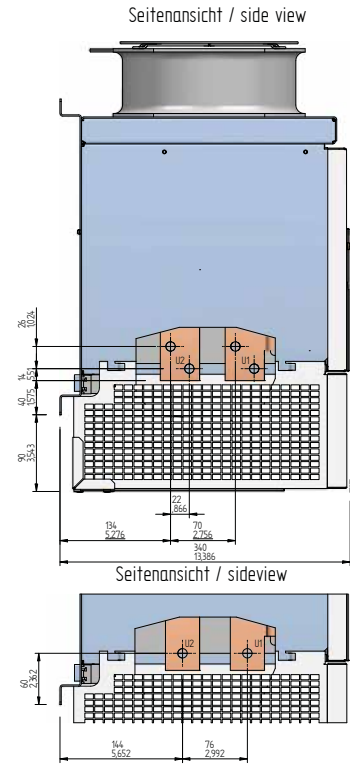
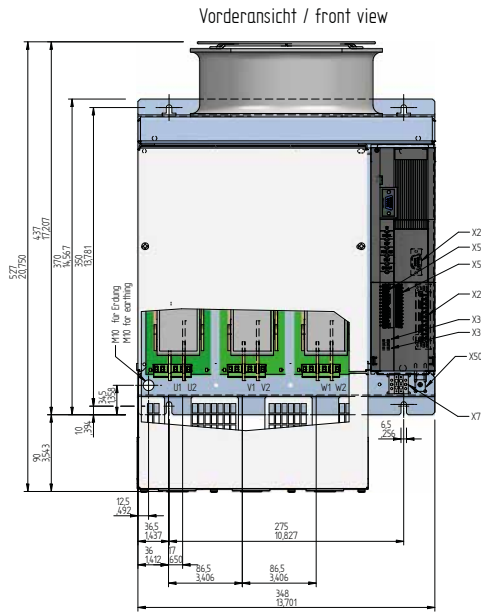

Thyro-P 3P (300 HF, 495 HF, 500 HF, 650 HF)

Dimensional Drawing 290





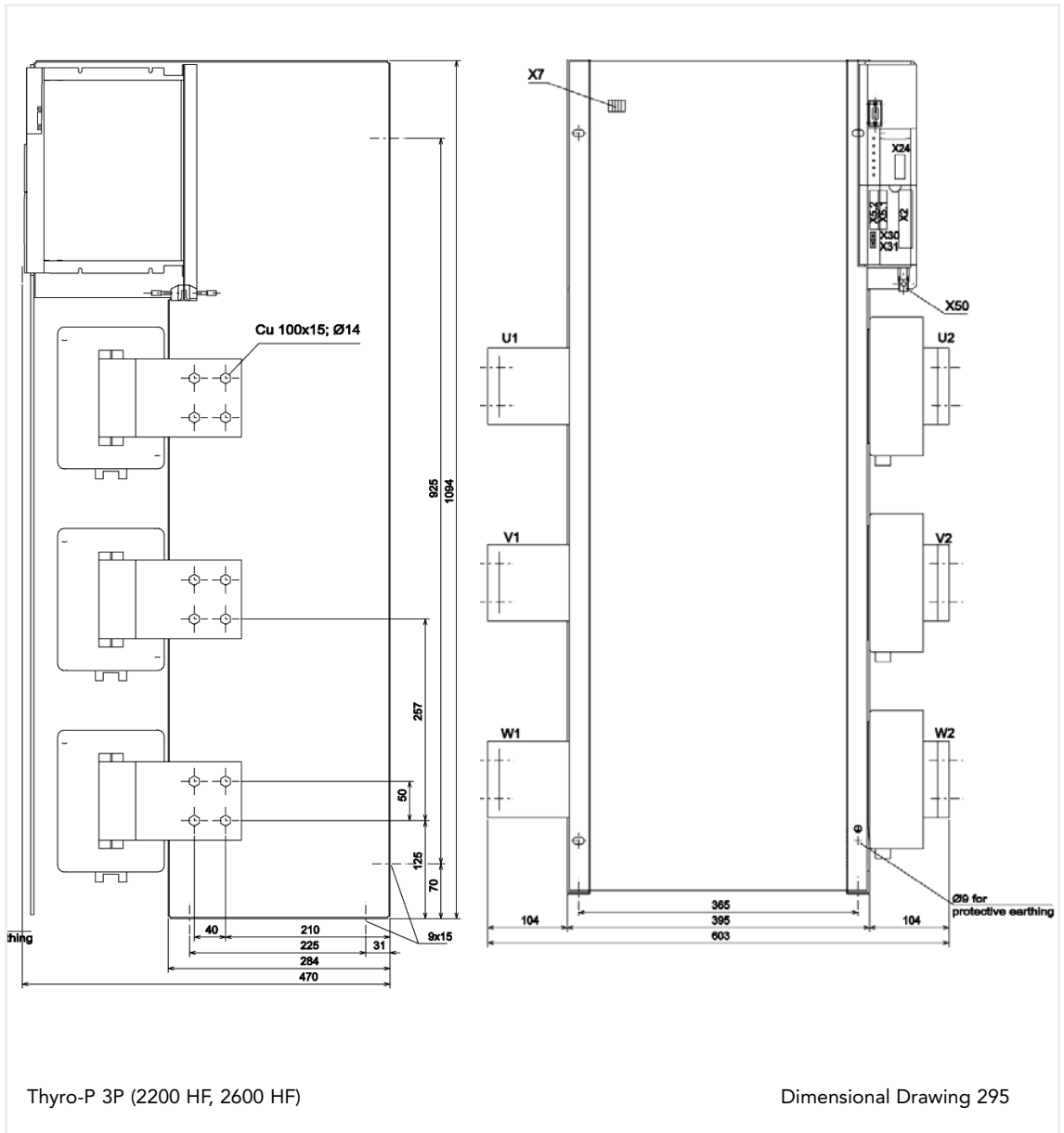

## 13. ACCESSORIES AND OPTIONS

ORDER NO.	DESCRIPTION
2.000.000.380	Thyro-Tool Family, commissioning and visualization tool for simple visualization tasks; software under Windows 95/NT4.0 and later
2.000.000.408	LBA-2 with touch display, Bluetooth and SD card
2.000.000.409	with touch display, Bluetooth and SD card
2.000.000.407	Thyro-P Bluetooth adapter
2.000.000.405	SEK, cabinet installation kit for LBA-2 installation in cabinet door
2.000.000.393	Interface card Profibus DPV1 with motor potentiometer feature
2.000.000.392	Interface card Modbus RTU with motor potentiometer feature
2.000.000.394	Interface card DeviceNet with motor potentiometer feature
2.000.000.396	Interface card Ethernet (Profinet, Ethernet IP, Modbus TCP)
2.000.003.203	Snubber board 690V for Thyro-P 1P, 2P, 3P > 600 V
6.000.000.244	DC eliminator for Thyro-P 1P in VAR
2.000.000.400	Control unit for Thyro-P 1P, 2P and 3P
2.000.000.401	Control device as described above plus ASM process for dynamic mains load optimization (not for new systems)
2.000.000.399	Voltage converter 690V/43V (UE_U=016), for DIN rail mounting
8.000.007.874	Connector 2 pol., for A70, X1
0048764	Data cable to PC (RS232), without crossing
37.295.190	LL/RS232C connector interface 9-pole incl. power supply
37.259.800	Fiber optic splitter, supply voltage LLV.V
37.259.900	LLV.4, Fiber optic splitter
0017381	Fiber optic connector
0017574	Fiber optic cables



## 14. APPROVALS AND CONFORMITIES

Due to European harmonization and international reconciliation, the standards will be subject to years of adjustment and renumbering. The detailed schedule therefore contains the current standards as well, even if the date for their expiry has already been set. There is no product norm for Thyristor Power Controllers, so that a sensible norm structure must be created from the corresponding basic norms, which ensures safe application and opportunity for comparison.



### CAUTION

Thyristor Power Controllers are non-valid devices for disconnection and may therefore be operated only in connection with a suitable mains isolating device (for instance switch) connected on line side. Approvals and conformities are available for Thyro-P:

- Quality standard according to ISO 9001
- Registration in acc. to UL 508, file no. E 135074  
- Investigated under consideration to Canadian National Standard C22.2 No. 14-95
- UL Markings:
  - Field wiring terminal markings (see chapter 4 EXTERNAL CONNECTIONS)
  - Use 60/75°C Copper Conductors only
  - Tightening torque (pound inches) see chapter 11 TECHNICAL DATA
  - Devices are suitable for the following short circuit current ratings:
    - Devices rated 300A
    - „Suitable For Use On A Circuit Capable Of Delivering Not More Than 100kA rms Symmetrical Amperes, xxx Volts Maximum, When Protected by RK5 Class Fuses, sized max. 600A / 600V“
    - Devices rated 495A and 695A:
    - „Suitable For Use On A Circuit Capable Of Delivering Not More Than 100kA rms Symmetrical Amperes, xxx Volts Maximum“



### NOTE:

xxx = max. allowable voltage depending upon rating of the device

- „Branch circuit protection must be provided and sized according National Electrical Code and any additional local codes“
- CE conformity
  - Low Voltage Directive 73/23 EEC;
  - EMV Directive 89/336 EEC;
  - Marking Directive 93/68 EEC
- Interference suppression
  - The RegTP confirms the compliance with the interference suppression regulations for the power control device

## IN DETAIL:

## CONDITIONS FOR USE OF THE DEVICE

Built-in unit		VDE 0160 5.5.1.3 VDE 0106 T 100:3.83	DIN EN 50 178
General requirements		VDE 0558 T 11	DIN EN 60146-1-1
Design, vertical installation		VDE 0558 T 1	
Operating conditions			DIN EN 60 146-1-1; K. 2.5
Operating location, industry sector		VDE 0875 part 3	CISPR 6
Temperature performance		VDE 0558 T 1	DIN EN 60 146-1-1; K 2.2
Storage temperature		-25°C - +55°C	
Transport temperature		-25°C - +70°C	
Operating temperature		-10°C - +35°C for external cooling (≥ 280A) -10°C - +45°C for self-air cooling -10°C - +55°C for reduced type current -2%/°C up to +40°C	
with UL applications			
Load class	1		DIN EN 60 146-1-1 T.2
Humidity class	B	DIN 40040	DIN EN 50 178 Tab. 7
Overvoltage voltage category	ÜIII	VDE 0110 T1	DIN EN 50 178 Tab. 3
Degree of pollution	2	VDE 0160 T 100	DIN EN 50 178 Tab. 2
Air pressure		900 mbar	≤ 1000 m above zero level
Safe isolation			
up to 500V mains voltage:		VDE 0160 chapter 5.6	DIN EN 50 178 chapter 3
Air and creeping distances according to DIN EN 50178		casing/mains potential	≥ 5,3 mm
		casing/control potential	≥ 5,3 mm
		mains voltage/control potential	≥ 7,2 mm and 10 mm in the power section
		interface/control potential	≥ 2,5 mm
		mains voltage/interface	≥ 7,2 mm
		mains voltage among themselves	≥ 5,5 mm
Test voltage		VDE 0160 Tab.6	DIN EN 50 178 Tab 18
Tests according to			DIN EN 60 146-1-1 4.
EMV noise emission		VDE 0839 T81-2	EN 61000-6-4
Radio interference suppression (control device)			
	class A	DIN EN 55011 VDE 0875 T11	CISPR 11
EMV noise resistance		VDE 0839-6-2	EN 61000-6-2
Compatibility level	class 3	VDE 0839 T2-4	EN 61000-2-4
ESD	≥ 8 kV	VDE 0847 T4-2:3.96	EN 61000-4-2
Electromagnetic fields	≥ 10V/m		EN 61000-4-3
Burst on mains lines	≥ 2kV	VDE 0847 T4-4:3.96	EN 61000-4-4
Burst on control lines	≥ 0,5kV		
Surge on mains lines	≥ 2kV		EN 61000-4-5
Surge on control lines	≥ 0,5kV		
Line-conducted			EN 61000-4-6

Further norms are observed, for instance voltage dips according to 61000-4-11 are ignored by the control device, or registered by triggering of monitoring. Generally, an automated start is made after the mains returns within tolerances.

Therefore, the conditions of the norm EN 61326 (controller standard) are also observed, even though this norm by its structure is not applicable to power electronics > 10 respectively > 25A.









**World Headquarters**  
1625 Sharp Point Drive  
Fort Collins, CO 80525 USA

970.221.4670 Main  
970.221.5583 Fax

[www.advanced-energy.com](http://www.advanced-energy.com)

Specifications are subject to change without notice.

© 2014 Advanced Energy Industries, Inc. All rights reserved. Advanced Energy® and Thyro-P™ are trademarks of Advanced Energy Industries, Inc.

