

Product Manual 1600, 1600i and 3200i

- | | |
|--|----------------------------------|
| 1 Introduction | 5 Installation and commissioning |
| 2 Dimensions and typical applications | 6 Customer presets and log |
| 3 Installation guidelines for EMC | 7 Trouble shooting guide |
| 4 Terminal specification and block diagram | 8 Detailed specification |

Please read and understand this manual prior to installing the unit. Please obtain expert help if you are not qualified to install this equipment. Make the safety of your installation a priority. This component is hazardous.

Introduction. Models 1600, 1600i, 3200i

Sprint Electric offers a family of D.C. THYRISTOR drive modules all with the same features and terminals. The user selects the appropriate model depending on required power output and the need for isolated electronics. The 1600 is NON-ISOLATED. The 1600i and the 3200i have isolated control electronics

| DRIVE TYPE | AC SUPPLY VOLTAGE | AMERICAN OPTIONS | NOMINAL OUTPUT | MAX. CURRENT | PRODUCT DISSIPATION at full current | ISOLATION |
|------------|-------------------|------------------|-----------------|-----------------|-------------------------------------|--------------|
| 1600/LV | 60/30 | | 48/24V | 16 AMPS | 50 watts | NON ISOLATED |
| 1600 | 240/110 | | 180/90V | 16 AMPS | 50 watts | NON ISOLATED |
| 1600i/LV | 60/30 | | 48/24V | 16 AMPS | 50 watts | ISOLATED |
| 1600i | 240/110 | | 180/90V | 16 AMPS | 50 watts | ISOLATED |
| 3200i/LV | 60/30 | | 48/24V | 8/16/32/48 AMPS | 25/50/100/150 watts | ISOLATED |
| 3200i | 415/240 | 240/110 | 320/180V(90 US) | 8/16/32/48 AMPS | 25/50/100/150 watts | ISOLATED |

All types are of open chassis construction for use in a suitable enclosure

GENERAL DESCRIPTION

The units employ closed loop control of both armature current and feedback voltage to give precise control of the motor torque and speed. The motor and drive are protected by a stall timer which automatically removes power after 30 seconds if the required speed cannot be achieved. The drives will provide up to 150% of the preset maximum current for up to 30 seconds allowing high short term torques during acceleration etc. Independant control of either the current or speed loops by external inputs allows torque or speed control applications with overspeed or overcurrent protection. The demand signal may be derived from a potentiometer, 0-10V signal or 4-20mA loop. The speed feedback signal may be selected to be the ARMATURE VOLTAGE or a shaft mounted TACHOMETER.

INPUTS AND OUTPUTS

| | | |
|----------------|------------------|--------------------------|
| +aux input | speed output | +24V unregulated output |
| -aux input | current output | +12V regulated output |
| current input | ramp output | +10V precision reference |
| 4-20mA input | demand output | -12V regulated output |
| 0 to 10V input | zero/stall relay | -24V unregulated output |

ADJUSTABLE PARAMETERS

| | | | |
|-----------|-----------|-------------|-----------|
| Max speed | Up ramp | Max current | Stability |
| Min speed | Down ramp | IR comp | |

SWITCHED FUNCTIONS

| | | |
|-----------------------|------------------|----------------|
| Maximum current range | Maximum feedback | Tacho feedback |
| Relay function | Power up hold | AV feedback |

JUMPER FUNCTIONS

| | | |
|--------------------------|---------------------|---------------------|
| Torque mode | Dual supply voltage | Phase angle limit |
| Zero reference interlock | 4-20mA input | 50% stall threshold |

PERFORMANCE FEATURES

| | | |
|-------------------|-----------------------------|------------------------|
| Dual loop control | Precision tacho rectifier | Compact design |
| Relay driver o/ps | International compatability | Systems inputs/outputs |

MECHANICAL DIMENSIONS

Note. Dissipation in watts is approx. 2 X arm. amps

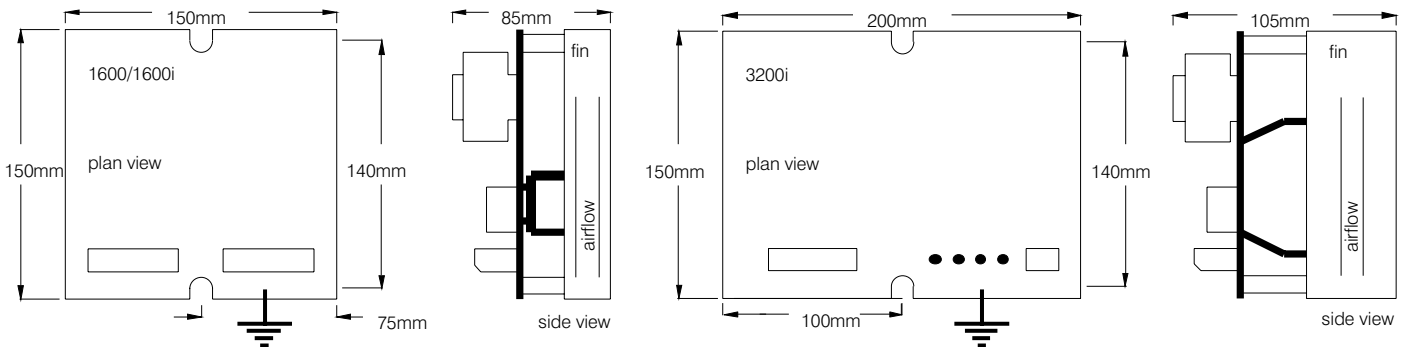

The unit should have a substantial earth connected to the heatsink earth screw provided. Employ a star washer adjacent to the heatsink for optimum earth continuity. The fixing bolts should be 5mm by 35mm for the 1600/1600i and 5mm by 50mm for the 3200 series.

TYPICAL APPLICATIONS

BASIC CONNECTION

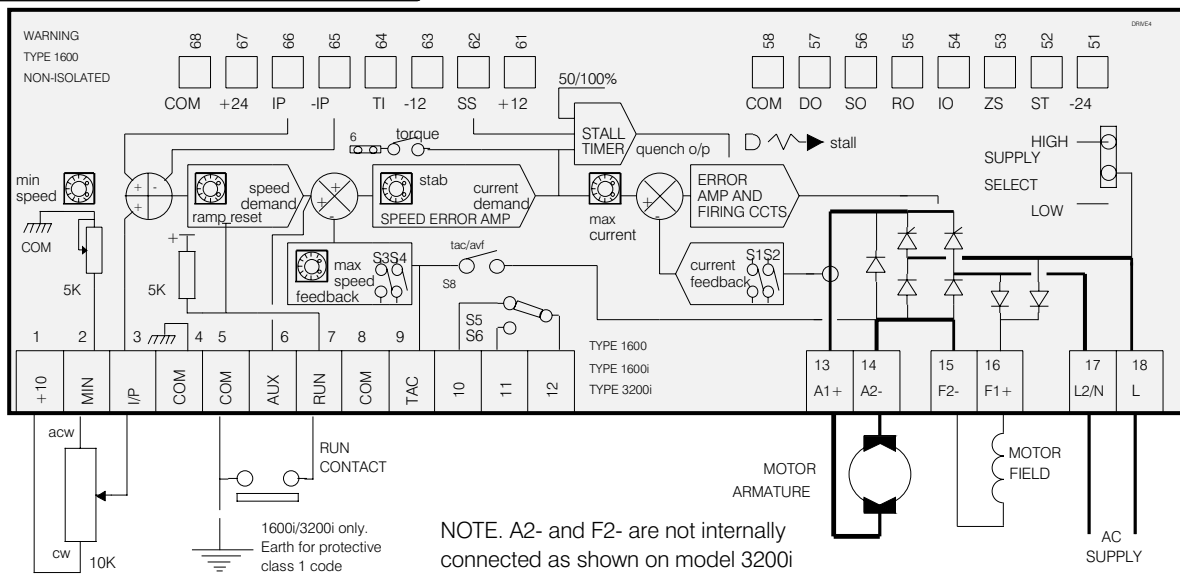

TORQUE CONTROL WITH OVERSPEED LIMITING BY SEPERATE SPEED SETPOINT.

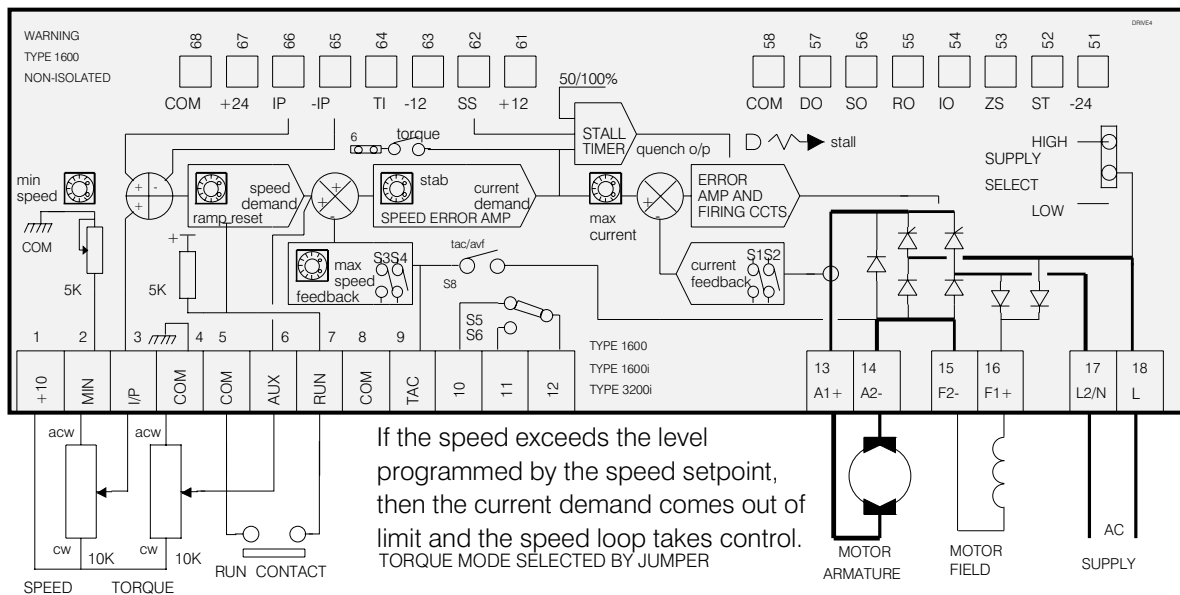

SPRINT ELECTRIC LTD. DOES NOT ACCEPT ANY LIABILITY WHATSOEVER FOR THE INSTALLATION, FITNESS FOR PURPOSE OR APPLICATION OF ITS PRODUCTS. IT IS THE USERS RESPONSIBILITY TO ENSURE THE UNIT IS CORRECTLY USED AND INSTALLED.

HEALTH AND SAFETY AT WORK. ELECTRICAL DEVICES CONSTITUTE A SAFETY HAZARD. IT IS THE RESPONSIBILITY OF THE USER TO ENSURE COMPLIANCE WITH ANY ACTS OR BYLAWS IN FORCE. ONLY SKILLED PERSONS SHOULD INSTALL THIS EQUIPMENT.

INSTALLATION GUIDE FOR SYSTEMS USED IN THE EU

Special consideration must be given to installations in member states of the European Union regarding noise suppression and immunity. According to IEC 1800-3 (EN61800-3) the drive units are classified as complex components only for professional assemblers, with no CE marking for EMC. The drive manufacturer is responsible for the provision of installation guidelines. The resulting EMC behaviour is the responsibility of the manufacturer of the system or installation. The units are subject to the LOW VOLTAGE DIRECTIVE 73/23/EEC and are CE marked accordingly.



Following the procedures outlined below will normally be required for the drive system to comply with the European regulations, some systems may require different measures. Installers must have a level of technical competence to correctly install. Although the drive unit itself is not subject to the EMC directive, considerable development work has been undertaken to ensure that the noise emissions and immunity are optimised.

* EN61800-3 specifies 2 alternative operating environments. These are the domestic (1st environment) and industrial (2nd environment). There are no limits specified for conducted or radiated emissions in the industrial environment, hence it is usual for the filter to be omitted in industrial systems.

Definition of an industrial environment. All establishments other than those directly connected to a low-voltage power supply network which supplies buildings used for domestic purposes.

DRIVE INSTALLATION REQUIREMENTS FOR EMC COMPLIANCE

Keep parallel runs of power and control cables at least 0.3m apart. Crossovers must be at right angles

Keep sensitive components at least 0.3m from the drive and power supply cables

The AC connections from the filter to the drive must be less than 0.3m or if longer, correctly screened

Do not run filtered and unfiltered AC supply cables together

Control signals must be filtered or suppressed eg control relay coils and current carrying contacts. The drive module has built in filters on signal outputs

The AC supply filter must have a good earth connection to the enclosure back plane. Take care with painted metal to ensure good conductivity.

The AC input filter has earth leakage currents. Earth RCD devices may need to be set at 5% of rated current

The metal enclosure will be the RF ground. The AC filter, drive earth and motor cable screen should connect directly to the metal of the cabinet for best performance

Linear control signal cables must be screened with the screen earthed at the drive end only. Minimise the length of screen stripped back and connect it to an analogue earth point

The motor cable must be screened or armoured with 360 degree screen terminations to earth at each end. The cable must have an internal earth cable and the screen must extend into the enclosure and motor terminal box to form a Faraday cage without gaps

The internal earth cable must be earthed at each end. The incoming earth must be effective at RF. **WARNING!** the earth safety must always take precedence.

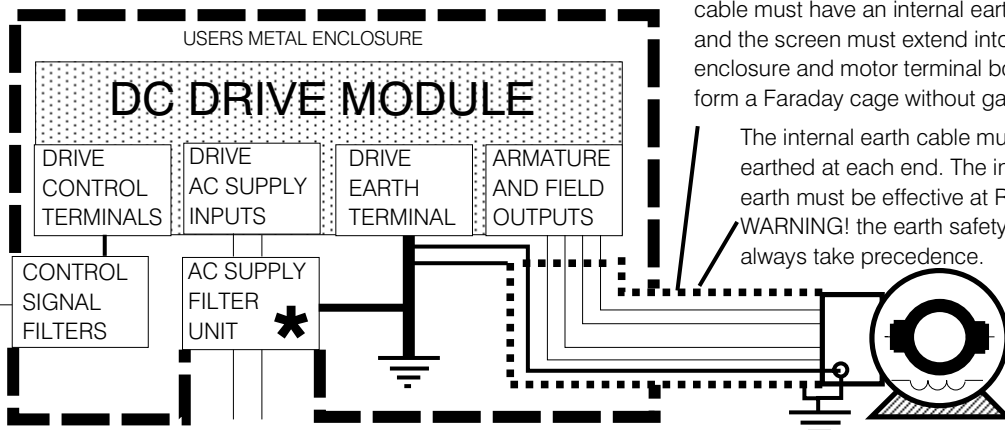

IMPORTANT SAFETY WARNINGS



The AC supply filters must not be used on supplies that are un-balanced or float with respect to earth

The drive and AC filter must only be used with a permanent earth connection. No plugs/sockets are allowed in the AC supply

The AC supply filter contains high voltage capacitors and should not be touched for a period of 20 seconds after the removal of the AC supply

MULTIPLE DRIVES WITH ONE FILTER AND EARTHING METHODS

The filter should be rated for the worst case total armature current load. The drive units are designed to function normally on unfiltered AC supplies shared with other thyristor DC drives. (not AC drives)

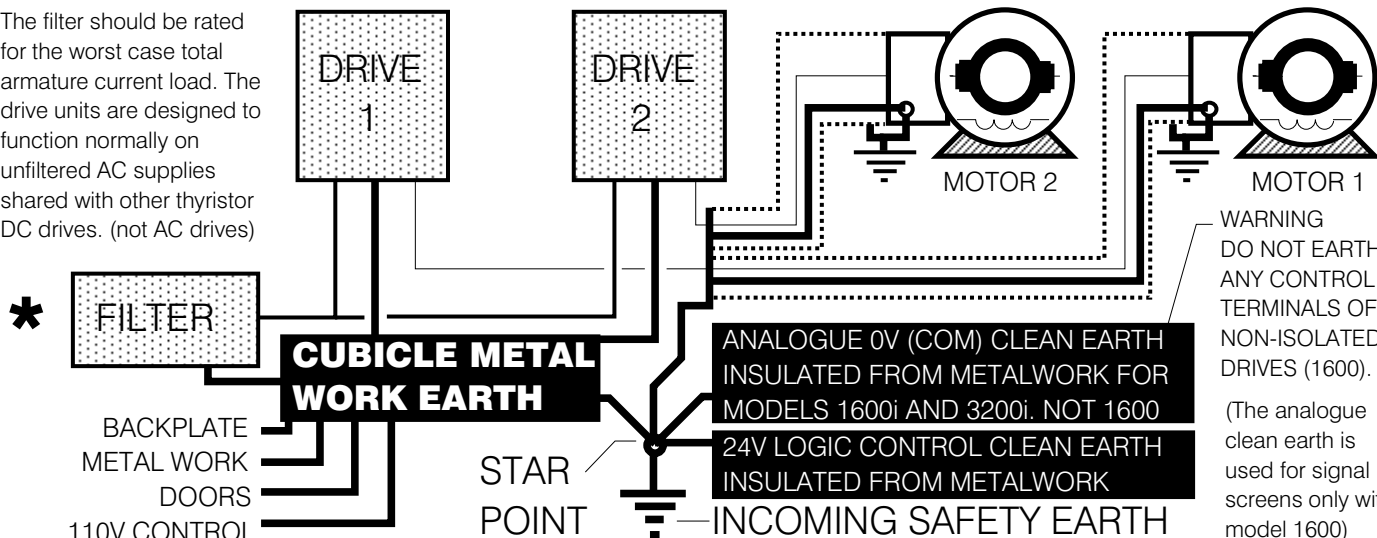

WARNING
DO NOT EARTH ANY CONTROL TERMINALS OF NON-ISOLATED DRIVES (1600).

(The analogue clean earth is used for signal screens only with model 1600)

Block diagram and terminal specification.

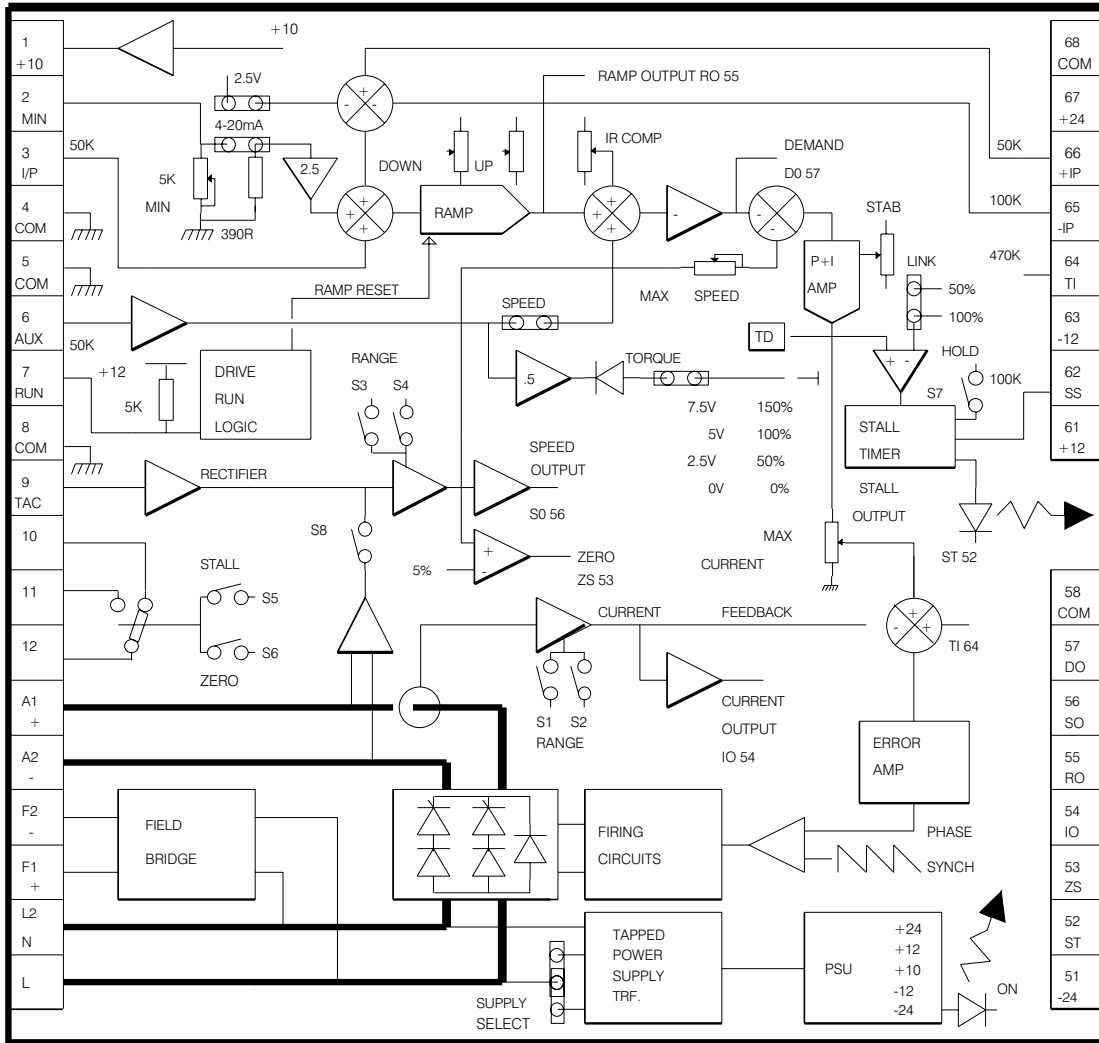

1 +10V PRECISION REFERENCE 10mA MAX. SHORT CTT. PROOF

2 MINIMUM END OF SETPOINT POT OR 4-20 mA CURRENT LOOP I/P

3 SPEED DEMAND INPUT 0-10V FOR 0-100% SPEED

4 COMMON. (4-20mA RETURN)

5 COMMON. (connect to earth for protective class 1 on 1600i and 3200i)
WARNING DO NOT EARTH 1600, this product is non-isolated

6 AUXILIARY INPUT. ON BOARD JUMPER SELECTS DIRECT SPEED OR TORQUE MODE. 0-10V FOR 0-100% CONTROL

7 CONNECT TO COMMON TO RUN 60ms ON / 20ms OFF

(WARNING. RUN is an electronic inhibit function. The field remains energised, and all power terminals remain 'live'. RUN must not be relied upon during hazardous operations)

8 COMMON (internally connected to T4, T5, T58, T68)

9 TACHO INPUT 25-400V FULL SCALE. + OR - POLARITY

10 RELAY CONTACT NC
11 RELAY CONTACT NO
12 RELAY POLE

| |
|--|
| RELAY CONTACT RATING 1 AMP 240V AC |
| RATINGS ACCORDING TO CSA |
| VOLTAGE RATING OF RELAY |
| TERMINALS 10/11/12 MUST NOT EXCEED 30V AC OR 42.4V DC. |

A1+ ARMATURE OUTPUT

A2-ARMATURE OUTPUT

F2- FIELD OUTPUT THE 3200i HAS TWO 2A FUSES WHICH PROTECT THE FIELD AND POWER SUPPLY TRANSFORMER ONLY. FOR A HALF WAVE FIELD VOLTAGE CONNECT FIELD TO F2- AND L2/N. THIS WILL GIVE AN OUTPUT OF 0.45 TIMES THE AC SUPPLY

F1+ FIELD OUTPUT

L2/N AC SUPPLY INPUT ACCORDING TO SUPPLY SELECT JUMPER

L AC SUPPLY INPUT ACCORDING TO SUPPLY SELECT JUMPER

68 DRIVE COMMON

67 +24V OUTPUT 25mA MAXIMUM DO NOT SHORT

66 AUXILIARY SPEED INPUT 0 TO 10V FOR 0-100% RAMPED SPEED

65 AUX. INVERTING SPEED INPUT 0 TO -10V FOR 0-100% RAMPED SPEED

64 INPUT TO CURRENT LOOP. 0-5V FOR 0-100% CURRENT

63 -12V OUTPUT 10mA MAX. DO NOT SHORT.

62 STOP/START INPUT. CLOSE TO -12V TO ACTIVATE STALL CONDITION. CLOSE TO +12V TO RELEASE STALL CONDITION.

61 +12V OUTPUT 10mA MAX. DO NOT SHORT.

58 DRIVE COMMON

57 SPEED DEMAND O/P 0 TO -10V REPRESENTS 0-100% DEMAND. OUTPUT IMPEDANCE 1K OHMS

56 SPEED OUTPUT. TYPICALLY 7.5V FULL SCALE. ADJUSTMENT OF MAX SPEED PRESET WILL ALTER THE FULL SCALE READING FROM 4V (ACW) TO 9V (CW).

55 SETPOINT RAMP OUTPUT 0-10V. IMPEDANCE 1K OHMS

54 CURRENT OUTPUT 0-5V FOR 0-100% OF CHOSEN RANGE (S1, S2). 1K IMPEDANCE.

53 ZERO SPEED RELAY DRIVER O/P MAX 100mA

Switches to -24V

52 STALL RELAY DRIVER O/P MAX 100mA

Switches to -24V

51 -24V RELAY SUPPLY 25mA DO NOT SHORT

SIGNAL PADS ON TOP EDGE (TERMINAL COMPATIBLE)

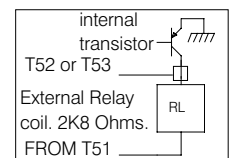

INSTALLATION AND COMMISSIONING

Ensure supply is disconnected before working on unit

POWER CABLING

Use correctly rated cable minimum 600V AC 2 times armature current

FUSING

The drives MUST BE FUSED EXTERNALLY with semiconductor fuses. The fuses must be rated at 1.75 times armature current and have an I²t rating lower than the value listed in the specification page 8. Any warranty will be invalid if the fusing is incorrect.

CONTROL SIGNALS

All control inputs to the 1600 are NON- ISOLATED. Do not connect any terminal to earth or other non-isolated voltage. The 1600i and 3200i have isolated control terminals, and may be connected to other systems. Avoid running signal cables close to power cables.

SUPPRESSION

The drives have excellent noise immunity. However installations involving electrical welding or RF induction heating may require further filters on the line and armature terminals. Contactor coils and sparking contacts may also require suppression. A 100R in series with 0.1uF cap. is usually adequate in these situations. Refer to page 3 for EMC guidelines.

PRESETS, SWITCHES, JUMPERS

Always use the correct insulated adjustment tools. Do not touch. Electric shock hazard exists!

MECHANICAL

Optimise heatsink airflow. Avoid vibration and ambient temps outside -10C and +40C. Protect the drive from pollutants.

MOTOR

Foot mounted motors must be level and secure. Protect motors from ingress of foreign matter during installation. Ensure accurate alignment of motor shaft with couplings. Do not hammer pulleys or couplings onto the motor shaft. Before running the motor complete the following check list.

- 1) Correct insulation resistance between all windings and earth with all drive cables disconnected
- 2) Check inside connection box for foreign objects, damaged terminals etc.
- 3) Check that brushes are in good condition, correctly seated and free to move in brush boxes. Check correct action of brush springs.
- 4) Motor vents must be freed of any obstruction or protective covers prior to running.
- 5) WARNING reversing systems. Do not transpose the armature connections until the motor has stopped. Failure to heed this warning will cause damage.

SUPPLY

Please ensure that the supply selection jumper on the drive matches the incoming supply. Failure to do this may result in permanent damage to the drive unit and will invalidate any warranty.

INITIAL SETTINGS

The drive units are shipped to run on the highest supply option at nominal speed, in ARMATURE VOLTAGE feedback mode, in the lowest current range. To change this run through switches S1 to S8 and select accordingly.

| | |
|-------|--|
| S1 S2 | Set switches to give desired current range |
| S3 S4 | SPEED. Calculate desired full scale feedback voltage and select range. Adjust within the range by using the MAX SPEED preset. Feedback may be tacho OR armature. |
| S5 S6 | Select according to desired relay function |
| S7 | Normally OFF. When on, the power up inhibit function will operate. Reset with T62. |
| S8 | ON for Armature voltage feedback. OFF for Tacho feedback. |

PRESET POT SETTINGS

MAX CURRENT. cw rotation gives 0 to 100% current limit. eg. 50% rotation gives 50% current limit. Check motor rating plate to find correct limit. (S1 S2 can provide 4 current ranges)

| | | |
|---------------|----------------------|----------------------|
| Anticlockwise | MIN SPEED UP RAMP | DOWN RAMP IR COMP |
| Midway | STAB | |

POWER ON

 Check ON lamp lights

CLOSE RUN CONTACT (see caution note on page 6)
Gradually increase external setpoint, check motor rotation. If the direction is wrong, TURN OFF and swap A+, A-

INCREASE SETPOINT.

Drive should ramp up to full speed. Fine adjust with MAX SPEED preset. Do not exceed armature voltage rating. Reduce setpoint, drive should ramp down to zero. Adjust MIN SPEED to desired level. Run motor up and down and adjust RAMPS.

STABILITY

Adjust STAB to improve response if necessary. Clockwise rotation gives faster response. Excessive rotation in either direction may lead to instability depending on load.

IR COMP

Speed droop may occur where armature voltage feedback is used. This is compensated for by clockwise rotation of IR COMP preset. Excessive rotation may lead to instability. No IR COMP is required for systems with tacho feedback.

TORQUE SYSTEMS

See typical applications. In this mode the lowest setpoint has priority. Hence the speed setpoint is set to demand a speed slightly in excess of the working speed, and then the torque setpoint will always be operating as a limit. In the event of a web break for example, the motor will only run up to the level set on the speed pot.

LAMPS

- ON** On indicates AC power is applied
- STALL** Stall lamp lights and drive quenches if stall timer trips. see below for description of timer characteristics.

PRESETS

- MAX SPEED** Rotate clockwise to increase speed. Change range with S3 and S4
- MIN SPEED** Rotate clockwise to increase minimum speed. Use to adjust 4-20mA loop burden resistor between 0 and 390R if 4-20mA mode is selected.
- UP RAMP** Rotate clockwise to increase drive acceleration. Span 1 to 30 seconds

- DOWN RAMP** Rotate clockwise to increase drive deceleration. Span 1 to 30 seconds. Note, natural coast down is a limit.

- STAB** Rotate clockwise to increase response. Excessive rotation may cause instability. If rated motor voltage is much lower than AC supply then anticlockwise is preferred.

- IR COMP** Rotate clockwise to increase level of armature voltage droop compensation. Excessive rotation may cause instability. Always set fully anticlockwise with tacho.

- MAX CURRENT** Rotate clockwise to increase current. Use S1 and S2 to select range



Anticlock

Midway

Clockwise

CUSTOMER PRESETS AND LOG

ON

STALL

MAX SPEED

MIN SPEED

UP RAMP

DOWN RAMP

STAB

IR COMP

MAX CURRENT

TORQUE SPEED

LINK FOR 4-20mA

50% STALL THRESHOLD

These two switches allow four maximum current ranges to be selected. 100% represents the maximum unit rating. The MAX CURRENT PRESET can be used to adjust from 0% to the selected maximum percentage

| | | | | | | | | |
|----|--|----------|----|--|-------|----|--|---------|
| S1 | | both off | S1 | | 0-75% | S2 | | both on |
| S2 | | 0-25% | S2 | | 0-50% | S2 | | 0-100% |

These two switches allow four maximum feedback voltage ranges to be selected. Use the MAX SPEED PRESET to adjust within the range. The drive will control from 0V to the selected maximum for a 0-10V input

| | | | | | | | | |
|----|--|----------|----|--|----------|----|--|----------|
| S3 | | both off | S3 | | 100-200V | S4 | | both on |
| S4 | | 25-50V | S4 | | 50-100V | S4 | | 200-400V |

These two switches allow the function of the relay to be determined

S5 when on the relay remains energised until a stall condition occurs

S6 when on the relay is energised for speeds above 5% of full scale. With both switches on, the relay de-energises when a stall condition occurs AND the motor speed has fallen below 5% of full scale

S7 **HOLD**. when on the drive will power up in a stall condition. It may be reset by momentarily shorting pad T61 to T62. (top edge)

S8 This switch allows the selection of the source of speed feedback. When on the **ARMATURE VOLTAGE** is selected. When off, a tacho.

SUPPLY SELECT This jumper selects the appropriate supply tap on the control transformer. Refer to specification for tolerances. CHECK model type
 1) 240/110V AC or 2) 60/30V AC

terminal 1 on

terminal 2 is loop I/P compliance 5V. terminal 4 return (0 - 20mA link lower pair only)

terminal 6 becomes TORQUE input, in SPEED position, terminal 6 is direct speed I/P

terminal 10 TACHO

| STANDARD | WITH 50% THRESHOLD |
|---------------|--------------------|
| 150% 30 secs | 150% 15 seconds |
| 125% 60 secs | 100% 30 seconds |
| 115% 120 secs | 75% 60 seconds |
| 100% no trip | 50% no trip |

terminal 11 10 12

terminal 13 COM

terminal 14 L-1 COM

terminal 15 L-2 RUN

terminal 16 L-3 COM

terminal 17 TACHO

terminal 18 10

terminal 19 11

terminal 20 12

terminal 21 +

terminal 22 -

terminal 23 -

terminal 24 +

terminal 25 N

terminal 26 L

terminal 27 +

terminal 28 -

terminal 29 L2/N

terminal 30 415

terminal 31 240

terminal 32 L

terminal 33 F2-

terminal 34 F1+

CAUTION

For frequent stopping or jogging it is not good practice to rely on switching the supply off and on to stop and start with the run contact permanently closed. This may result in an uncontrolled current pulse for one half mains cycle under certain conditions. Eg main contact bounce. This could lead to undesired motor movement or device damage. Use a spare NO contact on the main supply contactor in series with T7 and any other RUN contacts in rapid start systems



DANGER
ELECTRIC SHOCK RISK
The 3200i is 50 mm wider than 1600/1600i
A pair of 2A fuses protect the field and transformer. The supply select jumper is located at the top right edge (HIGH/LOW)

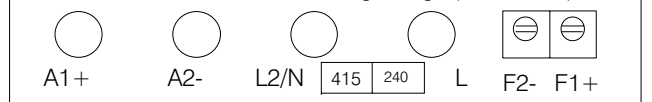

AC supply voltage legend, selector marked HIGH/LOW

TROUBLE SHOOTING.

The drive consists of 2 high accuracy feedback control loops.

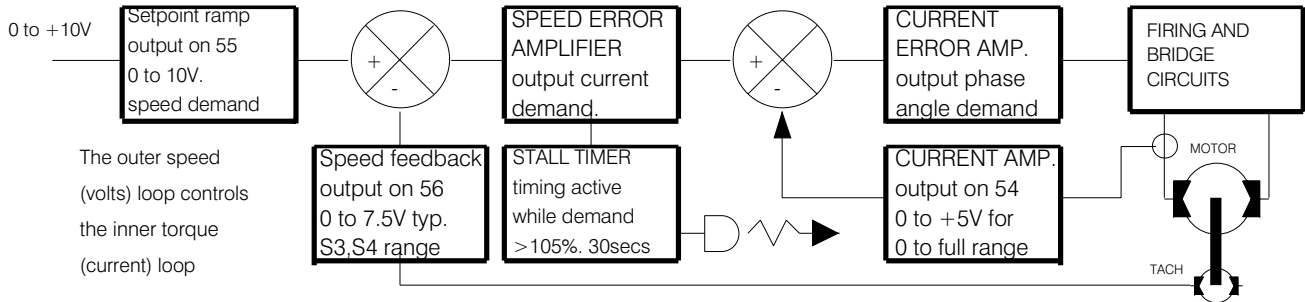

The outer speed (volts) loop controls the inner torque (current) loop

- | | | | |
|--|--|--|--|
| <p>1 The 1600 unit is NON isolated. DO NOT connect the electronics to earth or other non-isolated voltage.</p> <p>2 If you need to connect to other instruments, eg panel meter. Ensure that the instrument can float safely at high voltage</p> | <p>3 For systems involving connection to other controllers, you must use isolated drive models 1600i or 3200i</p> <p>4 Remember, all the wires, pots, contacts etc. that are connected to the terminals will be floating at mains potential.</p> | <p>5 STALL problems shown by stall lamp coming on after running are caused by the drive unit not able to give set speed</p> <p>6 Typical STALL reasons. a) MAX CURRENT preset not correctly set, hence insufficient torque</p> | <p>7 Motor not powerful enough for application. Speed calibration set beyond capability of supply.</p> <p>8 Any factor which prevents motor from rotating at set speed, eg. jammed load, low supply voltage.</p> |
|--|--|--|--|

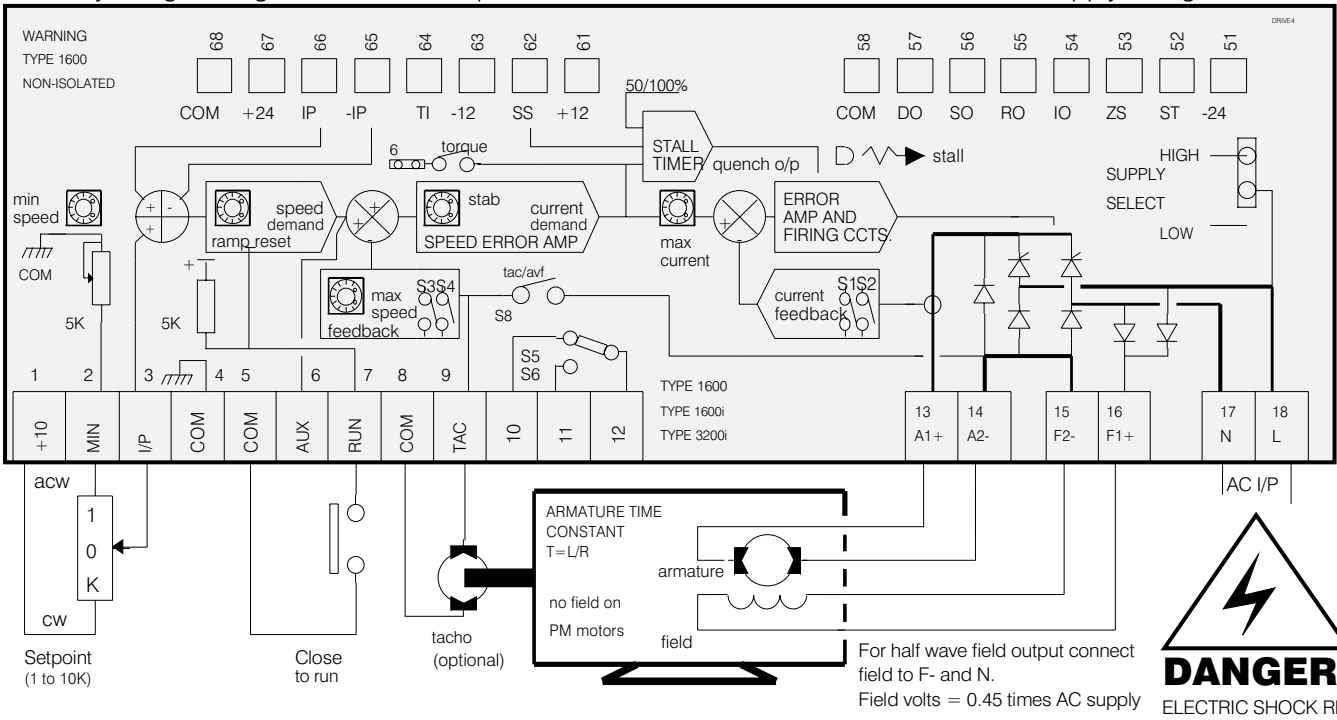

- | | | | |
|---|---|---|--|
| <p>9 Pot wired with T2 and T1 transposed. Motor slows down instead of speeding up</p> <p>10 Pot wired with T2 and T3 transposed. Motor slows down for clockwise rotation. T1 may be shorted to T2.</p> <p>11 Pot wired with T1 and T3 transposed. Motor slows down for anti-clockwise rotation. T1 becomes shorted to T2.</p> | <p>12 Loose or intermittent tacho coupling causes instability or overspeeding. Make sure coupling is secure and non-elastic</p> <p>13 Incorrect feedback scaling causes over or underspeeding. Calculate the desired max. tacho volts, adjust S3, S4</p> <p>14 Tacho failure. Until a replacement is obtained change to AV feedback S8. Rescale with S3, S4</p> | <p>15 Armature resistance should normally be a few ohms. The armature time constant must be greater than 10msecs</p> <p>16 Shorted turn on motor armature can cause power device failure. Check resistance through 360 deg rotation</p> <p>17 Brushes should be in good condition, correctly seated, and free to move in brush boxes.</p> | <p>18 Field resistance should normally be a few hundred ohms. The field must be isolated from earth and the armature</p> <p>19 Do not open circuit the field. Do not open circuit the armature unless RUN is opened first.</p> <p>20 The AC supply must lie within the limits specified on page 8. Ensure the selection jumper is correct.</p> |
|---|---|---|--|

SPECIFICATION

| FUNCTION | SPECIFICATION | COMMENTS | | | | | | | | | | | | | | | | | | |
|---|---|---|------|------|------|-----|-----|-----|-----|-----|------|------|------|-----|-----|-----|------|------|------|--|
| CONTROL ACTION FEEDBACK METHOD 0-100% REGULATION MAX TORQUE SPEED RANGE OVERLOAD | DUAL LOOP PROPORTIONAL + INTEGRAL ARMATURE VOLTS 2% TYPICAL 20 : 1 150% CONTINUOUS CURRENT FOR 30 seconds. | TACHOMETER 0.1% TYPICAL 100 : 1 | | | | | | | | | | | | | | | | | | |
| | | SWITCH SELECT BEWARE MOTOR HEAT AT LOW SPEED | | | | | | | | | | | | | | | | | | |
| <u>CUSTOMER PRESETS</u> MAX SPEED MIN SPEED UP/DOWN RAMPS STABILITY IR COMPENSATION MAX CURRENT | 25V - 400V FULL SCALE FEEDBACK 0-30% OF MAX SPEED INDEPENDANTLY ADJUSTABLE 1-30secs VARIES SPEED LOOP GAIN 0-30% OF ARMATURE VOLTAGE LINEAR SETTING FROM 0-100%, 4 SWITCHED RANGES | SWITCH SELECT NON-INTERACTIVE LINEAR RAMPS DO NOT USE WITH TACHO 150% OVERLOAD | | | | | | | | | | | | | | | | | | |
| <u>SWITCH SELECTABLE</u> CURRENT RANGE SPEED RANGE RELAY FUNCTION POWER UP HOLD TACHO/AVF | FOUR RANGES OF ARMATURE CURRENT FOUR RANGES OF FEEDBACK VOLTAGE DRIVE STALL OR ZERO SPEED RELAY POWER UP IN STALL OR RUN MODE SELECT TACHO OR ARMATURE VOLTAGE FEEDBACK | S1, S2 S3, S4 S5, S6 S7 S8 | | | | | | | | | | | | | | | | | | |
| <u>JUMPER FUNCTIONS</u> TORQUE MODE SUPPLY SELECT | 0-10V INPUT FOR 0-100% CURRENT WITH AUTOMATIC OVERSPEED PROTECTION. DUAL SUPPLY VOLTAGE SELECTOR | JUMPER SELECTED | | | | | | | | | | | | | | | | | | |
| <u>LINK FUNCTIONS</u> 4-20mA OR 0 -20mA LOOP 50% STALL LEVEL | ALLOWS CURRENT LOOP SIGNAL INPUT FOR SPEED ALLOWS LARGE PEAK CURRENTS | 5V COMPLIANCE 150% PEAK | | | | | | | | | | | | | | | | | | |
| SUPPLY RANGES 45HZ TO 65HZ AUTO RANGING | <table border="1" style="width: 100%; border-collapse: collapse; text-align: center;"> <tr> <td></td> <td>LV30</td> <td>LV60</td> <td>110</td> <td>240</td> <td>415</td> </tr> <tr> <td>MAX</td> <td>36V</td> <td>72V</td> <td>130V</td> <td>264V</td> <td>440V</td> </tr> <tr> <td>MIN</td> <td>27V</td> <td>54V</td> <td>100V</td> <td>200V</td> <td>360V</td> </tr> </table> | | LV30 | LV60 | 110 | 240 | 415 | MAX | 36V | 72V | 130V | 264V | 440V | MIN | 27V | 54V | 100V | 200V | 360V | OVER FULL TEMP RANGE WITH OUTPUTS LOADED |
| | LV30 | LV60 | 110 | 240 | 415 | | | | | | | | | | | | | | | |
| MAX | 36V | 72V | 130V | 264V | 440V | | | | | | | | | | | | | | | |
| MIN | 27V | 54V | 100V | 200V | 360V | | | | | | | | | | | | | | | |
| AC POWER UP RESET RUN LINE SIGNAL OUTPUTS SIGNAL INPUTS RELAY OUTPUTS RELAY DRIVERS RAIL OUTPUTS | MINIMUM OFF TIME BEFORE RE-SUPPLY 60mS ON, 20mS OFF. ALWAYS USE A RUN CONTACT TO ENABLE THE DRIVE AFTER THE APPLICATION OF AC SPEED, CURRENT, RAMP, DEMAND 3 SPEED INPUTS +/- RAMPED, DIRECT, ALL SUMMING STALL OR ZERO SPEED RELAY STALL, ZERO SPEED OPEN COLLECTOR PNP -24V UNREGULATED 25mA +12V, +10V, -12V REGULATED 10mA | 500mS ALL BUFFERED PROTECTED VOLT FREE CHANGEOVER FOR -24V DC 100mA MAX +/- 20% 0.01%/DEG C 5% | | | | | | | | | | | | | | | | | | |
| FIELD OUTPUT ALTITUDE HUMIDITY FORM FACTOR TEMPERATURE ARMATURE TIME CONSTANT MAX I ² FUSING (Amps ² Seconds) | 0.9(0.45) TIMES AC SUPPLY. 1600/1600i 1Amp, 3200i 2Amp 3000 METRES MAX FOR FULL RATING 85% R.H AT 40 C, NON-CONDENSING TYPICAL 1.5 AT MAX. OUTPUT STORAGE AND OPERATING -10 to +50C MINIMUM 10mS. USE EXTRA ARMATURE CHOKE TO INCREASE 1600 =365, 1600i =365, 3200i 8/16/32 =570, 3200i 48 =4750 | FULL(0.9) or HALF WAVE(0.45) DERATE 1%/100M T = INDUCTANCE/RESISTANCE SEMICONDUCTOR FUSES REFER TO SUPPLIER | | | | | | | | | | | | | | | | | | |

SPRINT ELECTRIC

Sprint Electric Limited

Ford, Arundel, West Sussex
UK

email info@sprint-electric.com
www.sprint-electric.com