

RCC2414 DATASHEET

**2 Digital Inputs, 4 Digital Outputs
1 Analog Input, 4 Analog Outputs**

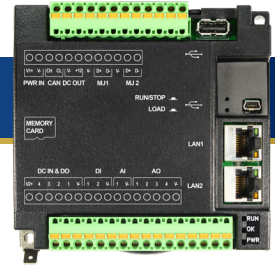

1 TECHNICAL SPECIFICATIONS

1.1 General

| | |
|------------------------------|---|
| Required Pwr. (steady state) | 120mA at 24VDC |
| Required Pwr. (inrush) | 25A for 1 ms at 24VDC switched |
| Primary Pwr. Range | 20-28VDC |
| Real-Time Clock | Yes |
| Clock Accuracy | +/- 8 seconds/month at 25°C |
| Relative Humidity | 5-95% non-condensing |
| Operating Temp. | -10°C to +60°C |
| Storage Temp. | -10°C to +70°C |
| Battery | Li-Ion Polymer Battery Charging Range 0-50°C |
| Weight | 10 oz / 283.5 g |
| Mounting | 35mm DIN Rail or Panel Surface |
| Housing Type | Plastic (UL 50 rated, flame retardant, UV resistant) |
| Certifications (CE) | USA: https://hornerautomation.com/certifications/ Europe: http://www.horner-apg.com/en/support/certification.aspx |

1.2 Control & Logic

| | |
|------------------------------------|---|
| Control Lang. Support | Advanced Ladder Logic or Full IEC 61131-3 Languages |
| Logic Size & Scan Rate | 128kb, 0.013ms/kB |
| Online Programming Changes | Supported in Advanced Ladder |
| PID Support | Up to 6 |
| Digital Inputs (%I) | 2048 |
| Digital Outputs (%Q) | 2048 |
| Analog Inputs (%AI) | 512 |
| Analog Outputs (%AQ) | 512 |
| Gen. Purpose 16-bit Registers (%R) | 4096 Retentive |
| Gen. Purpose 1-bit Registers (%T) | 2048 Non-Retentive |
| Gen. Purpose 1-bit Registers (%M) | 2048 Retentive |

1.3 Connectivity

| | |
|-----------------------|---|
| Serial | 2x2-wire RS485 |
| CAN | 1 x 125kbps - 1Mbps |
| Ethernet | 2 x 10Mbps/100 Mbps |
| microSD | 1 x SD, SDHC, SDXC in FAT32 format |
| USB | 1 x Mini Program 1 x USB Flash Drive |
| Communication Support | WebMI |
| | Web Portal |
| | Outgoing Email w/ Attachments |
| | TCP/IP and Modbus TCP/IP |
| | FTP |
| | Data Logging |

1.4 Digital DC Inputs

| | |
|--------------------------|-----------------------------|
| Inputs per Module | 2 |
| Commons per Module | 1 |
| Addressing | %I1 - %I2 |
| Input Voltage Range | 10-30VDC |
| Absolute Max. Voltage | 35 VDC Max. |
| Input Impedance | 10kΩ |
| Min. "On" Input | 8VDC |
| Max. "Off" Input | 3VDC |
| OFF to ON Response | 100μs min* |
| ON to OFF Response | 100μs min* |
| Galvanic Isolation | None |
| Logic Polarity | Positive |
| I/O Indication | None |
| High Speed Counter (HSC) | None |
| Connector Type | 5.08mm Pluggable Cage Clamp |

1.5 Digital DC Outputs

| | |
|------------------------------------|-----------------------------|
| Outputs per Module | 4 |
| Commons per Module | 1 |
| Addressing | %Q1 - %Q4 |
| Output Type | Sourcing/10 kΩ Pull-Down |
| Absolute Max. Voltage | 30VDC Max. |
| Output Protection | Short Circuit & Overvoltage |
| Max. Output Current/Point | 0.5A |
| Max. Total Current | 2A Total Current |
| Max. Output Supply | 30VDC |
| Min. Output Supply | 10VDC |
| Max. Voltage Drop at Rated Current | 0.25VDC |
| Max Inrush Current | 650mA/Channel |
| Min. Load | None |
| I/O Indication | None |
| Galvanic Isolation | None |
| OFF to ON Response | 100ms min* |
| ON to OFF Response | 15ms min* |
| PWM Out | None |

1.6 Analog Inputs

| | |
|---|---|
| Number of Channels | 1 |
| Input Ranges | 0 - 10 VDC |
| Addressing | %AI1 |
| %AI Full Scale Value | 32,000 |
| Max Input Voltage | -0.5 to +12VDC |
| Galvanic Isolation | None |
| Input Impedance (clamped @ -0.5 to 10.23 Vdc) | mA: 15 Ω +/- 1.5V V: 1.1MΩ |
| Nominal Resolution | 12 bits |
| Conversion Rate | One update/ladder scan |
| Max Error at 25°C (excludes 0°C) | 1.5% of full scale 0-10V - 1.5% of full scale |
| Filters | 270Hz hash (noise), 1-128 scan digital running average |

* all values updated 1x per scan

technical specifications continued...

1.7 Analog Outputs

| | |
|-----------------------------------|------------------------|
| Number of Channels | 4 |
| Output Ranges | 0 - 10VDC |
| Addressing | %AQ1 - %AQ4 |
| %AQ Full Scale Value | 32,000 |
| Galvanic Isolation | None |
| Nominal Resolution | 12 Bits |
| Maximum Current Load | 500Ω |
| Conversion Rate | One update/ladder scan |
| Response Time | One update/ladder scan |
| Max Error at 25° C (excludes 0°C) | 0.5% of full scale |

2 WIRING & JUMPERS

2.1 - Port Connectors

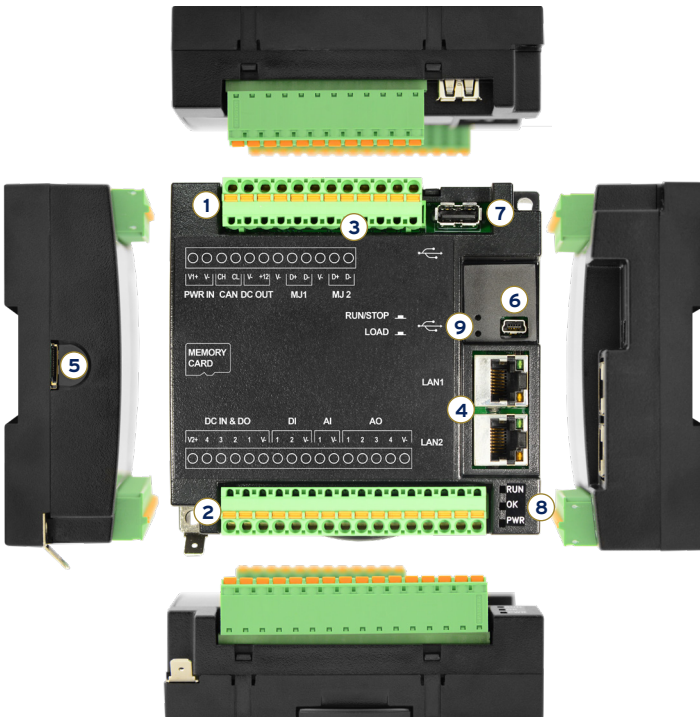

- | | | |
|----------------------------|-------------------------|---------------------|
| 1. Power & Comms Connector | 4. Ethernet Ports | 7. USB Flash Memory |
| 2. I/O Connector | 5. microSD Slot | 8. Status LEDs |
| 3. Serial Ports | 6. Mini USB Programming | 9. Buttons |

wiring & jumpers continued...

2.2 - Power Wiring

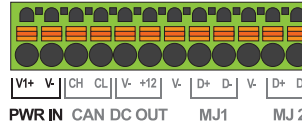

at the +12 terminal that is capable of 1 A maximum current.

To power up the RCC2414, supply 20-28VDC to the V+ and V- connections on the Power and Comms Connector. Additionally, a 12 V source is provided

2.3 - Digital Input Wiring

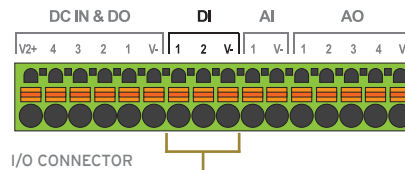

Digital inputs may be wired in A Positive Logic fashion as shown. The state of the inputs are reflected in registers %I1 and %I2.

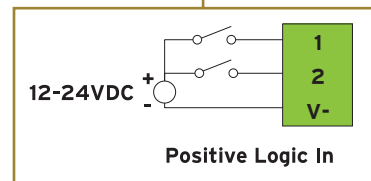

2.4 - Digital Output Wiring

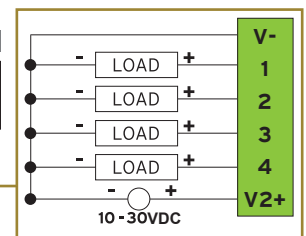
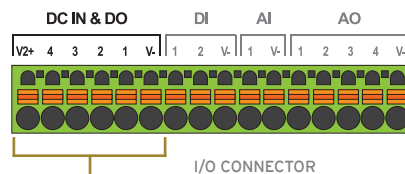

Digital outputs are Positive Logic. If an output is turned on, the voltage supplied at the V+ terminal is applied to that output. The state of the output may be controlled using the registers %Q1, %Q2, %Q3, and %Q4.

wiring & jumpers continued...

3 COMMUNICATIONS

2.5 - Analog Input Wiring

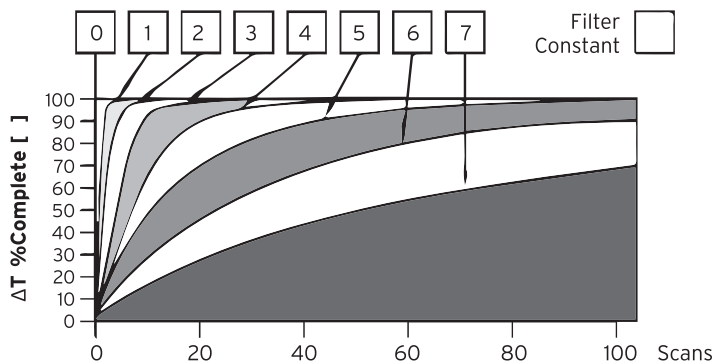
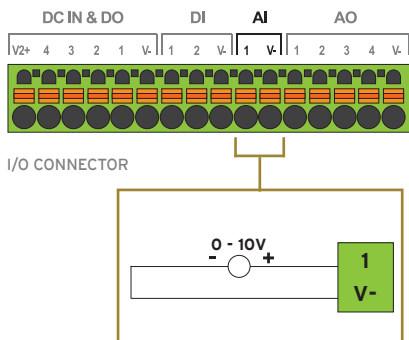

Raw input values for channels 1-4 are found in the registers as Integer-type data with a range from 0 - 32000.

Analog inputs may be filtered digitally with the Filter Constant found in the Cscape Hardware Configuration for Analog Inputs. Valid filter values are 0 - 7 and act according to the following chart.

2.6 - Analog Output Wiring

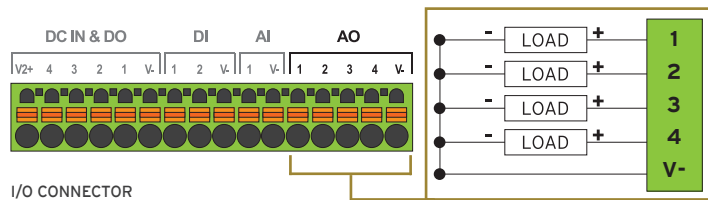

Each Analog Output has a range of 0-10VDC. The Analog Output registers %AQ1 - %AQ4 may be used to control the output by placing a value between 0 - 32000 into the register. This may be directly from a PID loop output or a conversion from a desired output from the touchscreen, for example.

3.1 - CAN Communications

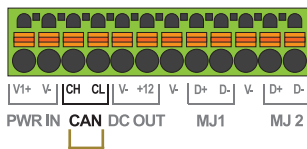

The CAN port is provided via three connections on the CAN, Power, and Analog connector: CAN_LOW (CL), CAN_HIGH (CH), and V- (C). It may be used to communicate with other OCS products using Horner's CsCAN protocol. Additionally, remote expansion I/O such as SmartRail, SmartBlock, and SmartStix may be implemented using the CsCAN protocol. If CsCAN expansion I/O is to be used, a 24VDC power source will be required on the CsCAN bus in order to power the expansion I/O modules.

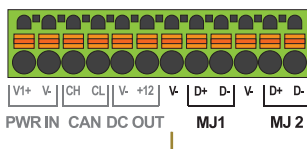

3.2 - Serial Communications

Two serial ports are provided via cage clamp terminals. Both are 2-wire RS-485 only. The most common use is for Modbus communications, either as a Modbus Master or Modbus Slave, though other options are also available.

3.3 - Ethernet Communications

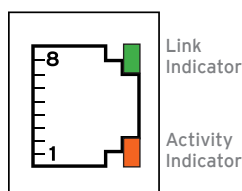

Two 10/100 Ethernet ports with automatic MDI-X (crossover detection) are provided via the 8-position modular jacks labeled "LAN1" and "LAN2". Several features are available for use over Ethernet, such as WebMI, Modbus TCP/IP, Ethernet/IP, SMTP (E-mail), expansion I/O to SmartRail, and more.

Ethernet configuration is done via the Cscape Hardware Configuration. For more information on Ethernet, available features and protocols, refer to the Ethernet Supplement document (SUP0740).

communications continued...

3.4 - microSD Slot

A microSD card may be used for data and alarm logging, historic trending, program loading, firmware updates, and many other features. Supported types of MicroSD cards are SD, SDHC, and SDXC as long as the format of the card file system is FAT32.

3.5 - Status LEDs



Three LEDs provide general status of the RCC:

| LED - Normal Functionality | | | |
|----------------------------|------------------|------------------|----------------------|
| LED TYPE | WHEN OFF | WHEN ON | WHEN FLASHING (1 Hz) |
| PWR | No power applied | 10-30VDC applied | N/A |
| OK | Self-test fail | Self-test pass | I/O forcing enabled |
| RUN | Stop mode | Run mode | Do I/O Mode |

LED - DIAGNOSTIC FUNCTIONALITY

When the OK and RUN are flashing alternately, a download is in progress. When the flashing stops, the download is complete and the unit reboots (allow 30 seconds). When flashing together, the download has failed, and the number of flashes indicates the error. There will be a two second gap and the pattern will be repeated. The number of flashes and the associated error are as follows:

- **2 Flashes** - The MAC ID is empty.
- **3 Flashes** - The internal MAC file is corrupt. 4 Flashes - The MAC ID TXT file is invalid.
- **5 Flashes** - The MAC ID file is not found or the microSD card is empty or missing system files.

communications continued...

3.6 - Buttons

Two recessed buttons provide control of several RCC modes. A paperclip may be used as the buttons are far enough recessed that a pen or pencil is not able to activate them.

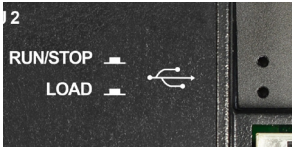

LOAD SWITCH

- Pressing the LOAD switch during power-up boots from the microSD card. This starts a Firmware Load if the microSD is bootable and valid firmware files are found on it.
- After boot-up, pressing the LOAD switch for 3 seconds either starts a Firmware Load or an Application Load depending upon what files are found on the microSD card. If firmware files are found, a Firmware Load is performed. If firmware files are not found and the DEFAULT.PGM file is found, an Application Load is performed.

RUN/STOP SWITCH

- After boot-up, pressing the RUN/STOP switch for 3 seconds toggles the RCC between RUN and STOP modes.

ERASE PROGRAM FUNCTION

- After boot-up, pressing both Load and RUN/Stop switches for 3 seconds performs an "Erase All" function, which deletes all application programs.

4 INSTALLATION DIMENSIONS

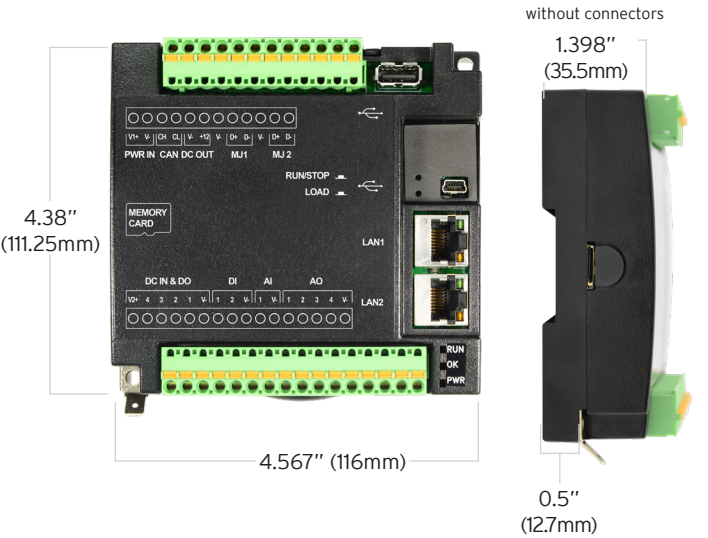

installation dimensions continued...

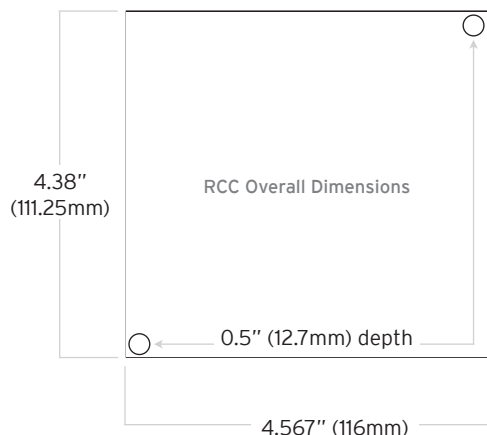

5 BUILT-IN I/O

5.1 Digital and Analog I/O Functions

| Registers | Description |
|--------------|-----------------|
| %I1 to %I8 | Digital Inputs |
| %I9 to %I15 | Reserved |
| %I16 | %Q Fault Status |
| %Q1 to %Q4 | Digital Outputs |
| %AI1 to %AI8 | Analog Inputs |
| %AQ1 to %AQ4 | Analog Outputs |

6 BATTERY

The RCC2414 uses a non-rechargeable 3 V Lithium coin-cell battery to run the real-time clock and to keep the retained register values. This battery is designed to maintain the clock and memory for 7-10 years. Please reference MAN1078 for more information about the battery.

7 SAFETY

7.1 - WARNINGS

- To avoid the risk of electric shock or burns, always connect the safety (or earth) ground before making any other connections.
- To reduce the risk of fire, electrical shock, or physical injury, it is strongly recommended to fuse the voltage measurement inputs. Be sure to locate fuses as close to the source as possible.
- Replace fuse with the same type and rating to provide protection against risk of fire and shock hazards.
- In the event of repeated failure, do NOT replace the fuse again as repeated failure indicates a defective condition that will NOT clear by replacing the fuse.
- Only qualified electrical personnel familiar with the construction and operation of this equipment and the hazards involved should install, adjust, operate, or service this equipment. Read and understand this manual and other applicable manuals in their entirety before proceeding. Failure to observe this precaution could result in severe bodily injury or loss of life.

7.2 - FCC COMPLIANCE

This device complies with part 15 of the FCC Rules. Operation is subject to the following two conditions:

- This device may not cause harmful interference
- This device must accept any interference received, including interference that may cause undesired operation

7.3 - PRECAUTIONS

All applicable codes and standards need to be followed in the installation of this product. Adhere to the following safety precautions whenever any type of connection is made to the module:

- Connect the safety (earth) ground on the power connector first before making any other connections.
- When connecting to the electric circuits or pulse-initiating equipment, open their related breakers.
- Do NOT make connection to live power lines.
- Make connections to the module first; then connect to the circuit to be monitored.
- Route power wires in a safe manner in accordance with good practice and local codes.
- Wear proper personal protective equipment including safety glasses and insulated gloves when making connections to power circuits.
- Ensure hands, shoes, and floor are dry before making any connection to a power line.
- Make sure the unit is turned OFF before making connection to terminals.
- Make sure all circuits are de-energized before making connections.
- Before each use, inspect all cables for breaks or cracks in the insulation. Replace immediately if defective.
- Use copper conductors in Field Wiring only, 60/75°C.

8 TECHNICAL SUPPORT

For assistance and manual updates, contact Technical Support at the following locations:

North America

+1 (317) 916-4274
 +1 (877) 665-5666
www.hornerautomation.com
techspt@heapg.com

Europe

+353 (21) 4321-266
www.horner-apg.com
technical.support@horner-apg.com

9 GLOBAL PART NUMBER

The global part number is HE-RCC8842.