



CAPACITIVE LEVEL METERS CLM – 36



Before level meters usage please read instructions in this service manual and keep it for further use. Service manual is for all types of level meters series CLM-36. Producer reserves the right to make changes without any previous announcement.

Content	2
I. Description	3
II. Technical specification	4-7
III. Types and performance of electrode.....	8
IV. Linearity.....	9
V. Mounting and dismounting	10-12
VI. Instalation of level meter and placing in operation	13
VII. Preparing of level meter for measuring	14
VIII. Setting of level meter with unknown value of permittivity of measured medium	15
IX. Setting of level meter with known value of permittivity of measured medium	16-18
X. Maintainance and service of level meter	19
XI. Protection, safety, compatibility and explosion proof	20
XII. Marking of level meters	21
XIII. Marking of labels	22-23
XIV. Accessories.....	24
XV. Table of relative permittivity (dielectric constants) of selected materials.....	25-26
XIV. Notes.....	27
Contacts	28

Capacitive level meters CLM-36 are designed for continuous level measurement of liquids, powders and bulk-solid materials in vessels, tanks, sumps, containers, silos, etc.

Variants according working areas:

- for non-explosive area: CLM-36N _ _ _ _
- for explosive area: CLM-36XI _ _ _ _

Available is high temperature performance for both working areas:

- high temperature performance for non-explosive area: CLM-36NT- _ _ _
- high temperature performance for explosive area: CLM-36XIT- _ _ _

Classification of areas:

Performance of level meter	Part of the level meter with electrode	Part of the level meter with housing
CLM-36N	non-explosive	
CLM-36NT	non-explosive	
CML-36Xi	II 1 GD T 83°C EX ia IIB T5 with ISIR ¹⁾	
	zone 0, zone 20	
CLM-36XIT	II 1/2 GD T 83°C EX ia IIB T5 with ISIR ¹⁾	
	zone 0, zone 20	zone 1, zone 21

The electrode and its surroundings (the wall of vessel, the reference tube, etc.) make capacitor. The electrode is designed according measured material:

- variant with rod electrode: CLM-36 _ _ -**10, 12**
- variant with rod electrode and reference tube: CLM-36 _ _ -**20, 22**
- variant with rope electrode: CLM-36 _ _ -**30, 31, 32**

Available is mechanical connection:

- with thread: CLM-36 _ _ _ -**M** M36x2
CLM-36 _ _ _ -**G** G1"
- without thread: CLM-36 _ _ _ -**CI** Triclamp

Inside of the level meter's housing is placed removable electronic module with adjustment elements (see chapter VII).

1) ISIR - Intrinsically safe isolating repeater (example IRU-420)

Type of level meter	CLM-36__-__-
Supply voltage: - var. N, NT - var. Xi, XiT	9 ÷ 36 V DC 9 ÷ 30 V DC
Current output: - non-activated electrode - full-activated electrode	4 mA 20 mA
Max. internal values of Xi version	U _i =30VDC, I _i =132mA, P _i =0,99W, C _i =370nF, L _i =0,9mH
Sensitivity ranges	20, 30, 50, 100, 150, 300, 500, 1000 pF
Maximum capacity of flooded electrode (range)	70, 250, 600, 1200, 3000, 7000, 18000, 36000 pF
Initial capacity regulation ratio	min. 1:2
Nonlinearity	max. 1 %
Temperature error	max. 0,05% / K
Voltage error	max. 0,3 µA / V
Internal resistance / electric strength (electrode - housing)	1 MΩ / 250 V AC
Coupling capacity / electric strength (housing - supply leads)	var. N 51 nF / 250 V AC var. Xi 26 nF / 500 V AC
Allowed temperature range in zone 0 (EN 50284)	-20 to +60°C
Allowed pressure range in zone 0 (EN 50284)	0,8 to 1,1 bar (0,08 to 0,11 MPa)
Protection class: - housing - connector type GDM 2009 - connector type GDM-K 2000	IP 67 IP 65 IP 67
Connector socket type Hirschmann DIN 43 650	GDM 2009 (standard) GDM-K 2000 (optional)
Recommended cable	2 x 0,75 mm ²
Max. load (serial) resistance (U = 24 V)	R _{max} = 750 Ω
Weight of the housing (without electrode)	var. N, Xi aprox. 0,5 kg var. NT, XiT aprox. 1 kg

Temperature resistance of CLM-36N(NT,Xi,XiT):

Variant of performance	Temperature of medium (at electrode)	Ambient temperature range t_a (at housing)	
		variant N	variant Xi
CLM-36__-10, 20-__	-40 to +200°C	-40 to +85°C	-40 to +75°C
CLM-36__-12, 22-__	-40 to +120°C	-40 to +85°C	-40 to +75°C
CLM-36__-30, 31, 32-__	-40 to +105°C	-40 to +85°C	-40 to +75°C

Pressure resistance of performance CLM-36N(Xi):

Variant of performance	Maximum operating overpressure	
	for $t_a = -40$ to $+20^\circ\text{C}$	for $t_a = -40$ to $+85^\circ\text{C}$
CLM-36__-10, 20-__	3 MPa	1 MPa
CLM-36__-12, 22-__	3 MPa	1 MPa
CLM-36__-30, 31, 32-__	1 MPa	0,5 MPa

Pressure resistance of high temperature performance CLM-36NT(XiT):

Temperature in connection point	+ 100°C	+120°C	+150°C	+180°C
Maximum overpressure	3,0 MPa	2,0 MPa	1,5 MPa	0,5 MPa

Used materials:

Part of the level meter (type)	Material	
	standard	optional
housing (all)	st. steel W. Nr. 1.4301	st. steel W. Nr. 1.4571, Incoloy 825 (W. Nr. 2.4858)
insulation bushing (all)	PTFE	-
electrode (10, 12, 20, 22)	st. steel W. Nr. 1.4301	st. steel W. Nr. 1.4571
electrode (30, 31, 32)	zinc coated steel rope	-
electrode coating (12, 22, 32)	FEP	-
electrode coating (30, 31)	polyolefin (modified PE)	PTFE
weight insulation (32)	PTFE	-
weight / anchor mechanism (30, 31, 32)	st. steel W. Nr. 1.4301	-
reference tube (20, 22)	st. steel W. Nr. 1.4306	st. steel W. Nr. 1.4571

Dimensions of each variants:

with rod electrode:

CLM-36__-10-_
CLM-36__-12-__

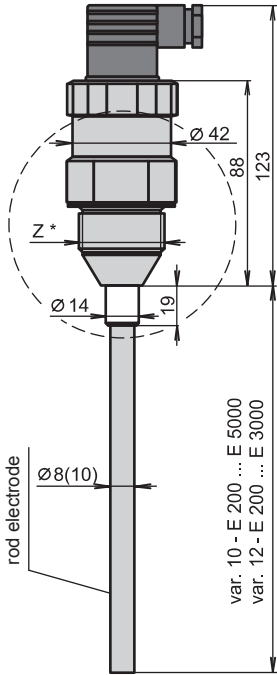

with rod electrode
and reference tube:

CLM-36__-20-_
CLM-36__-22-__

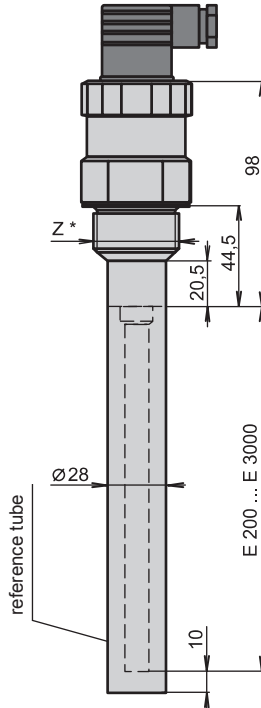

with rope electrode:

CLM-36__-30-__

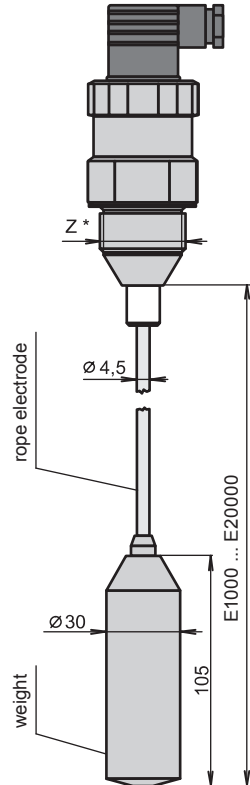

housing with thread:

CLM-36__-__-M
CLM-36__-__-G

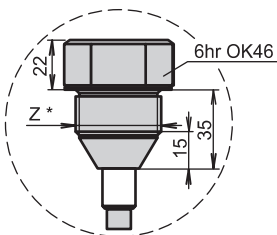

housing with Triclamp
coupling

CLM-36__-__-CI

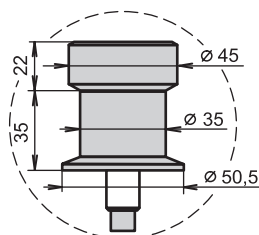

Z* - var. M - thread M-36x2
- var. G - thread G1"

Dimensions of each variants:

with rope electrode:

CLM-36 __-32-__

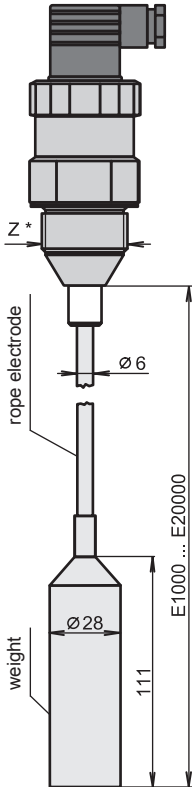

with rope electrode
with anchor:

CLM-36 __-31-__

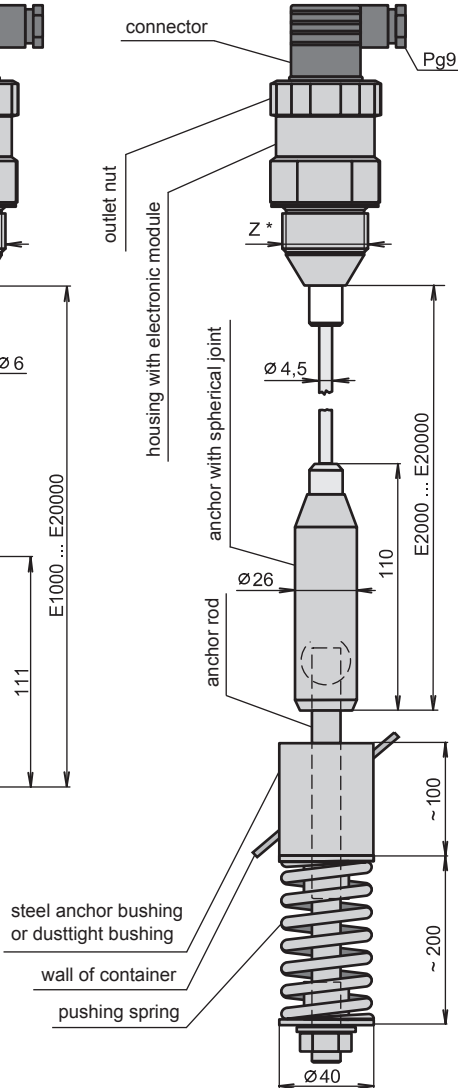

high temperature
performance:

CLM-36_T-__-__

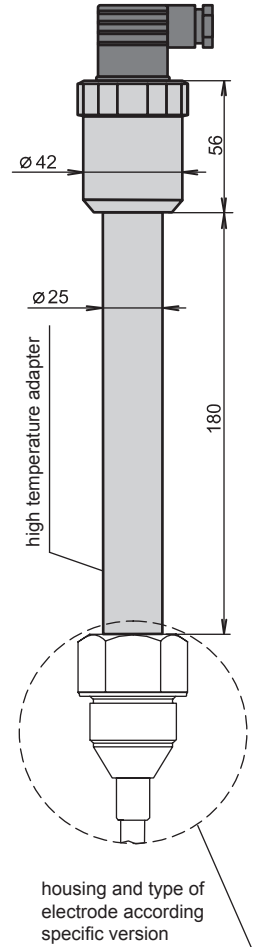

Characteristic of variants:

CLM-36__-10-__

With uncoated rod electrode - for level measurement of non-conductive liquids (oils, diesel, benzene) and bulk-solid materials (flour, sand, cement, plastic granulates, etc.). Max. electrode length 5 m.

CLM-36__-12-__

With coated rod electrode (FEP isolating) - for level measurement of water and other conductive liquids including waste liquids in metal vessels, concrete sumps, reservoirs, etc. Resistant against aggressive medium, lower adhesion to some mediums. Max. electrode length 3 m.

CLM-36__-20-__

With uncoated rod electrode and reference tube - for level measurement of clean non-conductive liquids (oils, diesel, benzene). By means of reference tube the output signal does not depend on the dimension and shape of the vessel. Impossible to use for waste and high viscosity liquids and bulk-solid materials. Max. electrode length 3 m.

CLM-36__-22-__

With coated rod electrode (FEP isolating) and reference tube - for level measurement of clean conductive liquids. Main use is for measurement in plastic and glass vessels and for fine measuring. Not suitable for waste water and high viscosity liquids and bulk-solid materials. Max. electrode length 3 m.

CLM-36__-30-__

With coated rope electrode (polyolefine isolating) and uncoated weight - for level measurement of bulk-solid materials (grains, sand, flour, cement, etc.). Max. electrode length 20 m.

CLM-36__-31-__

With coated rope electrode with anchor (polyolefine isolation) and uncoated weight - as the type 30. For use for higher silos. Max. electrode length 20 m.

CLM-36__-32-__

With coated rope electrode (FEP isolation) and coated weight (isolation PTFE) - for level measurement of conductive and non-conductive liquids. Max. electrode length 20 m.

Influence of the tank shape on a linearity of measured capacity of non-conductive liquids:

1. In the tank with straight wall (for example vertical cylinder) and with the sensor placed parallelly with the wall capacity change is linear.

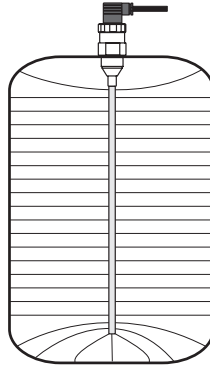

2. In a curved tanks (most frequently horizontal cylinder) capacity change during measuring of electrically non-conductive material is non-linear. Linearity is done by reference tube (CLM-36__-20, 22-).

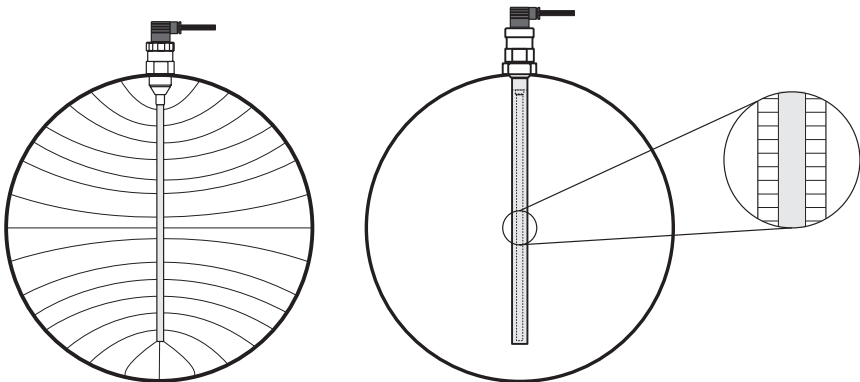

Level meters with coated electrode have protection cover at the end of electrode, which is necessary take down before mounting.

Level meters mount in vertical position to upper lid of tank or reservoir by steel welding flange ON-36x2 (steel 11375), stainless steel welding flange NN-36x2 (stainless steel 1.4301), fixing nut UM-36x2 (stainless steel 1.4301) or Clamp flange.

For mounting level meter to the metal tank or reservoir is not necessary to ground housing again.

In case of installation in concrete sumps or silos it is properly to install level meter at metallic auxiliary construction (console, lid, etc.) and then connect with metal all the time submerged object, eventually with steel armouring.

For measuring of material in plastic and glass vessels by level meter without reference tube is necessary to connect grounding screw at housing with auxiliary electrode which is fixed by the appropriate method to the outer casing of vessels (or at inner wall). Material of auxiliary electrode is necessary to choose with consideration to the working environment and properties of measured material.

Orientation of proportion for mounting of level meter (including eventually auxiliary electrode) shows following pictures.

CLM-36_ _-10, 12_ _

installation into the metal and non-metal vessels

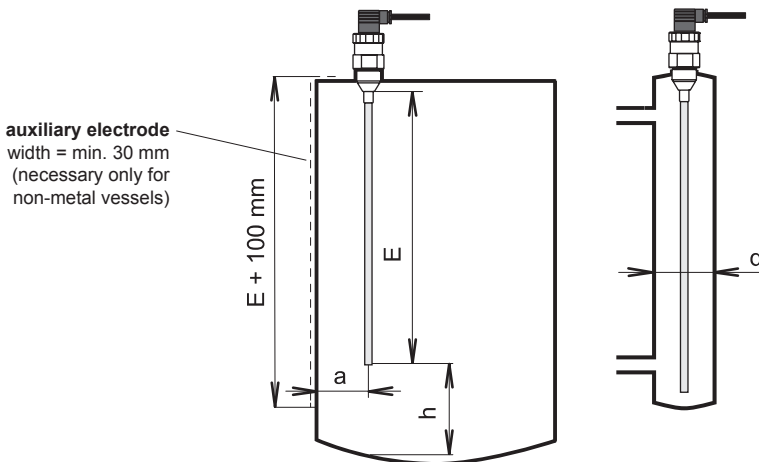

E - the length of electrode [mm] - the end of the electrode has to be dipped min. 20 mm below the lowest measured level

h - the distance from the bottom - min. 50 mm

a - the distance from the wall - min. approx. $E/20$

d - the diameter of auxiliary tube vessel - min. $40 + E/20$ (smaller dimension has to be discussed with producer)

CLM-36__-20, 22-__

installation with reference tube

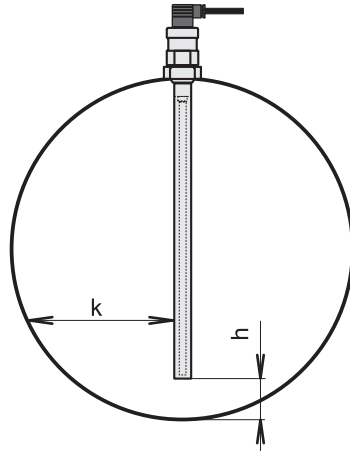

h - the distance from the bottom - min. 50 mm with respect on possibility of presence of heavy fraction (water) in oil products

k - the distance from the wall - optional

CLM-36__-30, 32-__

installation into the metal tank and concrete containers

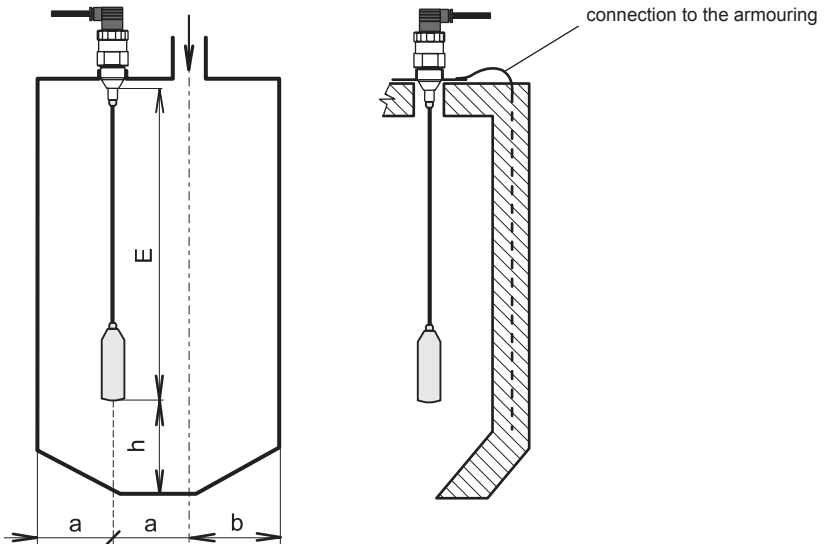

E - the length of electrode [mm] - the end of the electrode has to be dipped min. 20 mm below the lowest measured level

h - the distance from the bottom - min. 100 mm

a - distance from the wall - at least $E/20$, as far as possible from the walls, to the middle between the wall and the vertical inlet

CLM-36__-31-__

installation of rope electrode with anchor

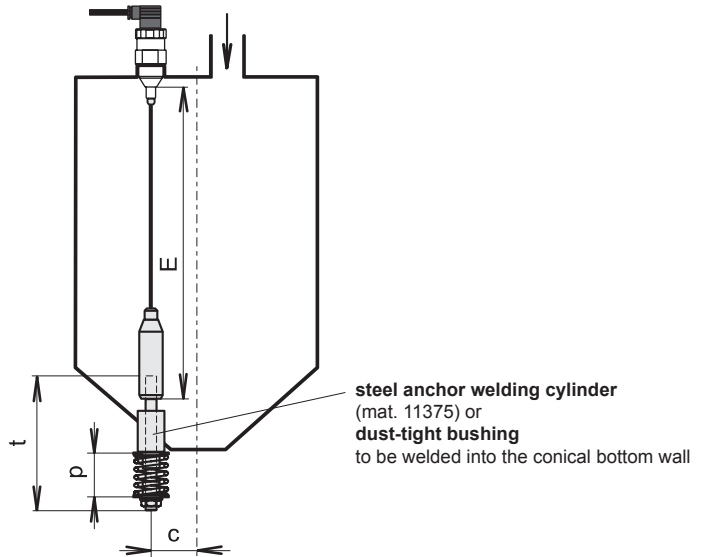

- E - the length of electrode [mm]
- c - the distance from the centre line of the silo - has to be as minimal as possible
- t - the length of the conduction rod - approx. 500 mm
- p - the length of the press spring - approx. 200 mm

Mounting, installation, placing in operation, maintainance, using and service of level meter CLM-36 must be done in conformity with this service manual and has to be performed according the norms for installation of electrical devices.

Electric connection of feeder cable is realized in state without voltage through the use of thread terminal in dismountable connector GDM at level meter's housing.

Positive pole of supply (+U) will be connected at terminal (1), negative pole of supply (0V) will be connected at terminal (2) - see following pictures.

Connection scheme of level meter

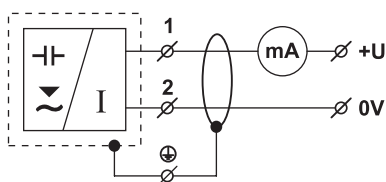

The inside scheme of the GDM connector socket

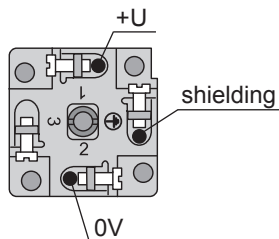

Cable from level meter to the further unit is by two-wire cable with outside diameter of $6 \div 8$ mm (recommended cross section of cores $0,5 \div 0,75$ mm²).

A shielded cable must be only used if the lead is longer than 30 m or in the event that a power line must be used simultaneously with the lead. Connect shielding to the socket \oplus , shielding do not connect to the power panel.

Power supply for variants CLM-36N and CLM-36NT can be by stabilized safety voltages power supply $9 \div 36$ V DC (SELV), example PSU-2400 or DSU-2400.

Or following evaluation device, for example programmable display unit PDU-4xx. For variants CLM-36Xi and CLM-36XiT must be connected with intrinsically safe isolating repeater $9 \div 30$ V DC, for example IRU-420.

Activation is by turning on of the power supply (for example PSU-2400 či DSU-2400 for variants CLM-36N and CLM-36NT) or intrinsically safe isolating repeater (for example IRU-420 for variants CLM-36Xi and CLM-36XiT).

Preparing of level meter

1. For access to the adjustment elements disconnect a connector and unscrew a nut (attention for inside connecting wires). Connector connect again.
2. Level meter connect to the supply unit through miliampermeter (controller, etc.).
3. Trimmer²⁾ 20 mA bring into the basic position (this position is set by producer):
 - a) Turn out trimmer totally right wards (in clockwise).
 - b) Return back for 3 turns left wards.

Adjustment elements of level meter

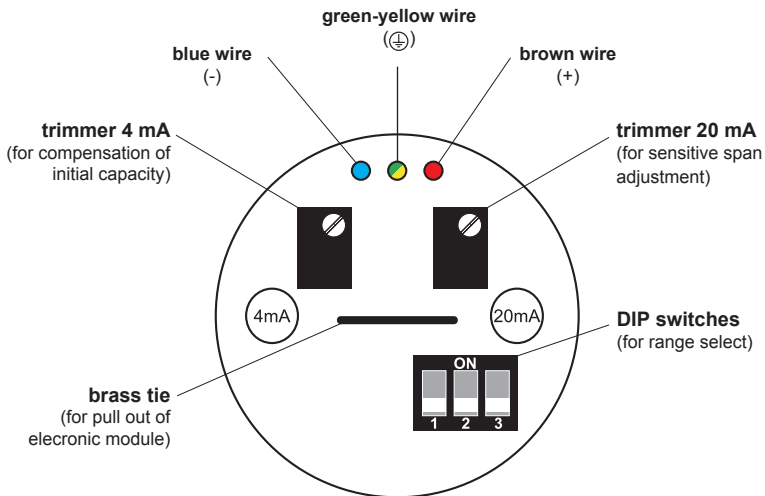

(the top view on the internal electronic module)

- 2) The trimmers are without backstops - approx. 15 turns.
- 3) Sensitivity - minimal capacity change of electrode to reach a current range $4 \div 20$ mA.
- 4) Range - maximum capacity of housing and activated electrode to reach current range $4 \div 20$ mA.
- 5) In case of short of electrode on housing or setting of a very sensitive range can caused to current restriction of level meter on value max. 30 mA.

Setting of level meter with unknown value of permittivity of measured medium

1. Empty tank to the minimum level.
2. By DIP switches on level meter set range⁴⁾ No. 2 (250 pF).
3. Turn by screwdriver in **trimmer 4 mA** and set quiescent current of the level meter to 4 mA. Turning right wards (in clockwise) increase the current, turning left wards decrease the current. When is impossible to set required current to 4 mA, then switch DIP switches to the nearest higher range and set up of current 4 mA perform at this range.
4. Fill the tank to the maximum level. When it is impossible fill the tank to the maximum state then we use some known (measurable) level and current for next setting calculate according to formula:

$$I_{out} = 4 + (0,16 \times \text{level in } \%) \text{ [mA]}$$
5. By DIP switches step wise switch to higher ranges till the current is greater then 20 mA (or calculated value I_{out}), through level meter then flows current e.g. 21 mA⁵⁾. **Trimmer 20 mA** is still in basic position.
6. Then set by **trimmer 20 mA** current of level meter to 20 mA (or to calculated value I_{out} - see bellow).
7. To reach a maximum accuracy is useful to check over the setting of 4 mA (compensation of initial capacity - quiescent current).

Table of ranges:

No.	Sensitivity ³⁾ (S)	Range ⁴⁾ (R)	Position of DIP switch
1 ⁶⁾	20 pF	70 pF	
2	30 pF	250 pF	
3	50 pF	600 pF	
4	100 pF	1 200 pF	
5	150 pF	3 000 pF	
6	300 pF	7 000 pF	
7	500 pF	18 000 pF	
8	1 000 pF	36 000 pF	

6) Range No. 1 (70 pF) is very sensitive and we recommend to use it only at level meters with short electrode (approx. to 500 mm) and measured media with low permittivity.

Setting of level meter with known value of permittivity of measured medium

1. Calculation of measuring range:

- a) Count sum of **capacity of housing** (CH) and **capacity of non-activated electrode** (CNE).

$$C1 = CH + CNE$$

Capacity of housing (typical values)	CH
Capacity of housing - normal performance	21 pF
Capacity of housing - high temperature performance	28 pF

Capacity of non-activated electrodes (electrode length 1000 mm)	CNE (air)
all types without reference tube in distance 250 mm from conducting wall	12 ÷ 15 pF
uncoated rod electrode with reference tube (type 20)	approx. 50 pF
coated rod electrode with reference tube (type 22)	approx. 55 pF

- b) Count sum of **capacity of housing** (CH) and **capacity of activated electrode** (CAE) - selected mediums see the table.

$$C2 = CH + CAE$$

Capacity of activated electrodes (electrode length 1000 mm)	CAE (benzine)	CAE (water)
all types without reference tube in distance 250 mm from conducting wall	25 ÷ 30 pF	500 pF (coated electrode)
uncoated rod electrode with reference tube (type 20)	approx. 100 pF	-
coated rod electrode with reference tube (type 22)	approx. 110 pF	500 pF

- c) Set the possible ranges - **capacity of housing and activated electrode (C2) will not be greater than range value (R).**

$$C2 < R$$

- d) Sensitivity check - **difference of capacity activated (CAE) and non-activated (CNE) electrode must be greater than sensitivity** of calculated range.

$$C2 - C1 > S \quad (CAE - CNE > S)$$

- e) Choose the range - both previous conditions must be used **together** c) and d).

2. Empty the tank to the minimum level.
3. By DIP switches on level meter set up **pre-counted range**.
4. Turn by screwdriver in **trimmer 4 mA** and set quiescent current of the level meter to 4 mA. Turning right wards (in clockwise) increase the current, turning left wards decrease the current. When is impossible to set required current to 4 mA, then switch DIP switches to the nearest higher range and set up of current 4 mA perform at this range.
5. Fill the tank to the maximum level. When it is impossible fill the tank to the maximum state then we use some known (measurable) level and current for next setting calculate according to formula:

$$I_{out} = 4 + (0,16 \times \text{level in } \%) \quad [\text{mA}]$$
6. On preliminary range of level meter set by **trimmer 20 mA** current of level meter to 20 mA (or to calculated value I_{out} - see bellow). Turning rightwards (in clockwise) increase the current, turning left wards decrease the current.
7. To reach a maximum accuracy is useful to check over the setting of 4 mA (compensation of initial capacity - quiescent current).

Example of calculation:

Level meter CLM-36N-20-M E1000, measured medium is benzine ($\epsilon_r = 2,2$), distance from wall to level meter with uncoated rod electrode with reference tube is optional.

- 1.a) Sum of capacity of housing and non-activated electrode:

$$C1 = CH + CNE = 21 + 51 = \mathbf{72 \text{ pF}}$$

- 1.b) Sum of capacity of housing and activated electrode:

$$C2 = CH + CAE = 21 + 100 = \mathbf{121 \text{ pF}}$$

1.c) Possible ranges:

C2 < R

121 pF < **(2) 250 pF**, (3) 600 pF, (4) 1200 pF, (5) 3000 pF, (6) 7000 pF,
(7) 18000 pF, (8) 36000 pF

1.d) Check the sensitivity:

C2 - C1 > S

C2 - C1 = 121 - 72 = **49 pF**

49 pF > (1) 20 pF, **(2) 30 pF**

1.e) Recommended accurate range:

range (2) 250 pF

Level meter CLM-36N-20 with electrode E = 1000 mm by flowage of benzine has capacity 120 ÷ 135 pF - typical measuring range is range (2) 250 pF.

Typical measuring ranges of CLM-36 with electrode 1 m, 2 m and 5 m length for selected medias:

Medium Type	Sand, grains		Cement		Flour	
	1 m	5 m	1 m	5 m	1 m	5 m
10	2	3	2	4	1	3
12	2	3	2	4	1	3
30	2	3	2	4	1	3
31	2	3	2	4	1	3

Medium Type	Water		Benzine, petroleum, diesel, oils	
	1 m	2 m	1 m	2 m
10	-	-	1	2
12	3	4	1	2
20	-	-	2	3
22	3	4	2	3
32	3	4	1	2

Note: Types 10, 12, 30, 31, 32 in distance 250 mm from conducting wall.
Showned ranges are orientation. Exact range for existing configuration electrode / tank must be set directly in application on mearured medium.

Maintenance of level meter

Maintenance of device is to control the housing of level meter and lead-in cable. In case of any visible damages please contact producer or supplying company.

At level meter is prohibited to perform any changes or repair without producer confirmation.

Service of level meter

Eventual reparation of mechanical damage of level meter must be done by producer or by producer authorized service organization.

Replacement of defective electronic

In case of detected electronic failure it is possible to replace the electronic module directly in process place of level meter by following procedure:

1. Disconnect connector and unscrew a nut (attention for inside connecting wires).
2. Defective electronic module pick up by pliers onto brass tie and remove by tensile from housing of level meter.
3. Check placing of white seal O-ring in housing and on pressure ring.
4. Repaired or new electronic module return back into housing of level meter and press down by clamping ring (attention that contact pin will be a little open before insertion and contact springs were not pressed under level of electronic casing).
5. Check placing of black seal O-ring on connector.
6. Screw a nut back (attention for inside connecting wires) and connect the connector.

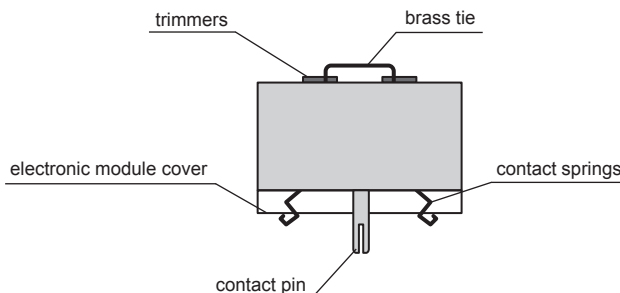

Protection

Level meter is equipped with protection against reverse polarity of supply voltage and against overvoltage.

Safety

Safety against dangerous contact is ensure by safe power supply according norm EN 33 2000-4-41 (SELV).

Compatibility

Electromagnetic compatibility is provided by conformity with norms EN 55022/B, EN 61326-1, EN 61000-4-2, EN 61000-4-3, EN 61000-4-4, EN 61000-4-5, EN 61000-4-6.

Explosion proof

Explosion proof of CLM-36Xi and CLM-36XiT is examined by FTZU-AO 210 Ostrava - Radvanice, certificate No. 02 ATEX 0235X.

Special conditions for safe use

Equipment is designed to be connected to isolating repeater IRU-420

If other approved apparatus is used, which output parameters comply with above mentioned input parameters it is necessary to have an galvanic separation or in a case of apparatus without galvanic separation (Zener barriers) it is necessary to provide equipotential equalizing between sensor and barrier earthing point.

Design CLM-36Xi can be used in zone 0 or zone 20. With design CLM-36XiT can be only used in zone 0 and zone 20 electrode part and head with electronics can be used only in zone 1 or zone 21. Maximum temperature of electrodes is equal to temperature of measured medium.

When used in zone 0 the present explosive atmosphere of air mixture and gases, vapours or mists must comply with: $- 20^{\circ}\text{C} < T_{\text{amb}} < 60^{\circ}\text{C}$ $0,8 \text{ bar} < p < 1,1 \text{ bar}$

Method of marking of level meters CLM-36

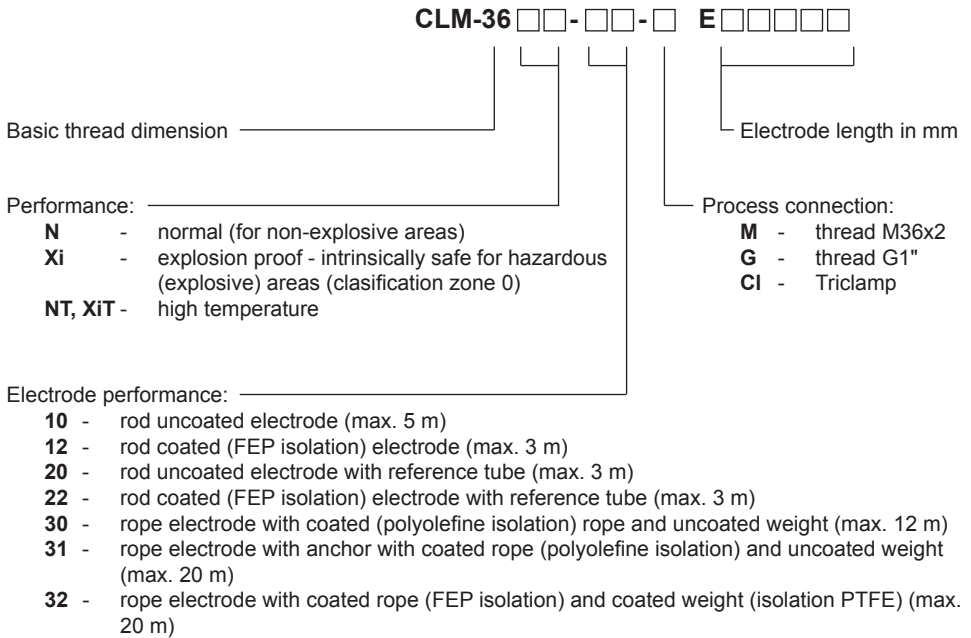

Examples of correct marking

CLM-36N-10-G E1100
 CLM-36XiT-20-M E900
 CLM-36N-12-Cl E2000
 CLM-36NT-12-M E1500
 CLM-36Xi-30-M E12000
 CLM-36N-32-G E6000

On label of level meter type CLM-36N(T) are following datas:

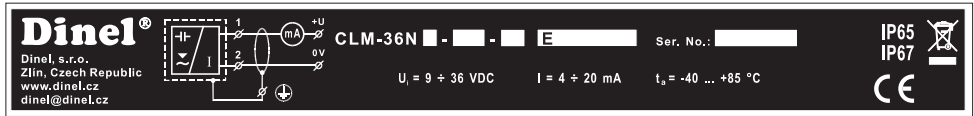

- symbol of producer: logo Dinel®
- contact: Dinel, s.r.o., Zlin, Czech Republic, www.dinel.cz, dinel@dinel.cz
- connection scheme and labelling of wires: +U, 0V, GND
- type of level meter: CLM-36-N_ - _ - , include length of electrode: E in mm
- serial number: Ser. No.: xxxxx - production year (first two position) and sequence factory number (next three position)
- power supply voltage: $U_i = 9 \pm 36$ V DC
- output current range: $I = 4 \pm 20$ mA
- ambient temperature range: $t_a = -40 \dots +85$ °C
- protection degree: IP 65 / IP 67
- label : CE
- symbol of electro-equipment for back collection and separate collection of electro-waste

On label of level meter type CLM-36Xi are following datas:



- symbol of producer: logo Dinel®
- contact: Dinel, s.r.o., Zlin, Czech Republic, www.dinel.cz, dinel@dinel.cz
- connection scheme and labelling of wires: +U, 0V, GND
- type of level meter: CLM-36-Xi- _ - _ , include length of electrode: E in mm
- serial number: Ser. No.: xxxxx - production year (first two position) and sequence factory number (next three position)
- label of non-explosive device: Ex in hexagon
- performance: II1GDT83°C ExialIBT5
- number of authorized person examining control of system quality: 1026
- number of certificate of intrinsically safety: FTZU 02 ATEX 0235X
- limiting operating parameters: $U_i = 30$ V DC, $I_i = 132$ mA, $P_i = 0,99$ W, $C_i = 370$ nF, $L_i = 0,9$ mH
- ambient temperature range: $t_a = -40 \dots +75$ °C, $t_a = -20 \dots +60$ °C (zone 0)
- protection degree: IP 65 / IP 67
- label : CE
- symbol of electro-equipment for back collection and separate collection of electro-waste

On label of level meter type CLM-36XiT are following datas:



- symbol of producer: logo Dinel®
- contact: Dinel, s.r.o., Zlín, Czech Republic, www.dinel.cz, dinel@dinel.cz
- connection scheme and labelling of wires: +U, 0V, GND
- type of level meter: CLM-36-XiT-__-__, include length of electrode: E in mm
- serial number: Ser. No.: xxxxx - production year (first two position) and sequence factory number (next three position)
- label of non-explosive device: Ex in hexagon
- performance: II1/2GDT83°C ExialIBT5
- number of authorized person examining control of system quality: 1026
- number of certificate of intrinsically safety: FTZU 02 ATEX 0235X
- limiting operating parameters: $U_i = 30 \text{ V DC}$, $I_i = 132 \text{ mA}$, $P_i = 0,99 \text{ W}$, $C_i = 370 \text{ nF}$, $L_i = 0,9 \text{ mH}$
- ambient temperature range: $t_a = -40 \dots +75 \text{ °C}$, $t_a = -20 \dots +60 \text{ °C}$ (zone 0)
- protection degree: IP 65 / IP 67
- label : CE
- symbol of electro-equipment for back collection and separate collection of electro-waste

Standard accessories:

For each level meter:

- 1 pc of connector socket GDM 2009 (IP 65)
- 1 pc of seal (material AFM)

For each delivery (each 5 pcs):

- 1 pc of screwdriver for adjustment

Optional accessories:

For mounting of level meter:

- stainless fixing nut UM-36x2 (material stainless steel 1.4301)
- steel welding flange ON-36x2 (material steel 11375)
- steel welding flange with lock and AI seal ON-36x2-Z (material steel 11375)
- stainless welding flange NN-36x2 (material stainless steel 1.4301)

Other:

- connector socket GDM-K 2000 with 5 m of cable (IP 67)
- seal (on request - material PTFE, AI, etc.)

Table of relative permittivity (dielectric constants) of selected materials

Material	ϵ_r
Acetone	19,5 ÷ 21,4
Acetylentetrachloride	8,1
Aminoplasts	5 ÷ 8
Ammonia	15 ÷ 24
Aniline	6,9
Ash	1,5 ÷ 1,7
Benzaldehyde	18,3
Benzene	2,28 ÷ 2,3
Benzol	2,3
Celluloide	3,5 ÷ 6,2
Cement	4,0
Dioxane	2,235
Ebonit	2,5 ÷ 5
Ethanol	24
Ethylacetate	6,0
Ethyleneglycol	38,7
Ethylenechloride	10,5
Flint crystal	4,5
Flour	2,5 ÷ 3,0
Food salt (NaCl)	6,0
Freon R22	6,1
Fused quartz	3,7
Gasoline (benzin)	2,0 ÷ 2,2
Glass	3,7 ÷ 10
Glass organic	3 ÷ 3,6
Glass silicate	16
Glazed carton	3,5
Glycerine	47
Grains	3,0 ÷ 5,0
Hardened textile	2 ÷ 6
Hexane	1,9

Material	ϵ_r
Chloroforme	4,81
Ice	3,1
Liquefied air	1,5
Liquefied CO2	1,6
Liquefied chlore	2,0
Liquefied propan	1,6 ÷ 1,9
Marble	9,3 ÷ 11,6
Methanol	32,7 ÷ 33,8
Mica	5 ÷ 8
Mikanite	4,5 ÷ 6
Milk powder	3,5 ÷ 4
Monochlorbenzene	4,0
Nitrobenzene	35,7
Ortonitrotoluene	27,4
Paper	1,6 ÷ 2,6
Paraffin	1,9 ÷ 2,5
Paraffin oil	1,9 ÷ 2,5
Paraffinic oil	2,2
Petroleum	2,0 ÷ 2,2
Polyacetal	3,6 ÷ 3,7
Polyamide - PA	4,0 ÷ 5,0
Polydichlorstyrole	2,7
Polyetheretherketone -	3,2
Polyetherimide - PEI	3,0
Polyethylene - PE	2,16
Polyfenylenesulfide - PPS	3,3
Polymethylmetakrylate	2,56
Polypropylene - PP	2,0 ÷ 2,2
Polystyrole	2,39
Polysulphone - PSU	3,0
Polytetrafluorethylene	2,0 ÷ 2,1

Table of relative permittivity (dielectric constants) of selected materials

Material	ϵ_r
Polyvinylacetate	2,7
Polyvinylchloride - PVC	2,51 ÷ 3,1
Polyvinylidene fluoride	6,0 ÷ 7,4
Porcelain	4,5 ÷ 7
Pyridine	13,6
Rape-seed (colza) oil	2,8
Resin - acrylic	2,4 ÷ 4,5
Resin - epoxy	2,5 ÷ 8,0
Resin - melamine	4,7 ÷ 10,2
Resin - phenolic	4,0 ÷ 12,0
Resin - polyester	2,8 ÷ 8,1
Resin - styrene	2,3 ÷ 3,4
Resin - ureal	5,0 ÷ 8,0
Rubber	2,0 ÷ 6,0
Sand	3,0 ÷ 5,0
Silicon caoutchouc	2,8 ÷ 3,3
Succinite	2,9
Sugar	3,0
Sulphur	3,4 ÷ 3,6
Toluene	2,3 ÷ 2,38
Trichlorethylene	3,43
Trolitule	2 ÷ 2,6
Vaseline	2,2 ÷ 2,9
Water	81
Water solution	50 ÷ 80
White beeswax	2,0 ÷ 2,9
Wood - damp	10 ÷ 30
Wood - dry	2 ÷ 6



Dinel, s.r.o.
U Tescomy 249
760 01 Zlín
Czech Republic

phone: (+420) 577 002 003
fax: (+420) 577 002 007

e-mail: sale@dinel.cz

www.dinel.cz