

PT9420 Installation Instructions

updated 3.19.07



WARNING

Remove spool locking screw prior to installation!

Do not free release measuring cable!

Do not over extend measuring cable!

Limit misalignment to 5° maximum!

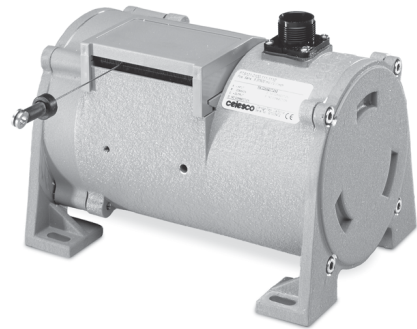

MECHANICAL

1. Mount transducer via the 4 feet to a flat solid surface.
2. Connect measuring cable to moving object.

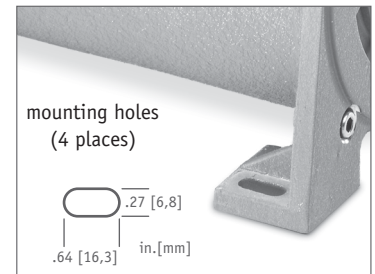
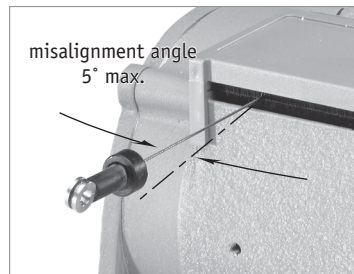

ELECTRICAL

3. Connect system wiring.
4. If desired, use the zero and span controls to calibrate to exact measurement range (see below).

2-Wire System (non hazardous area)

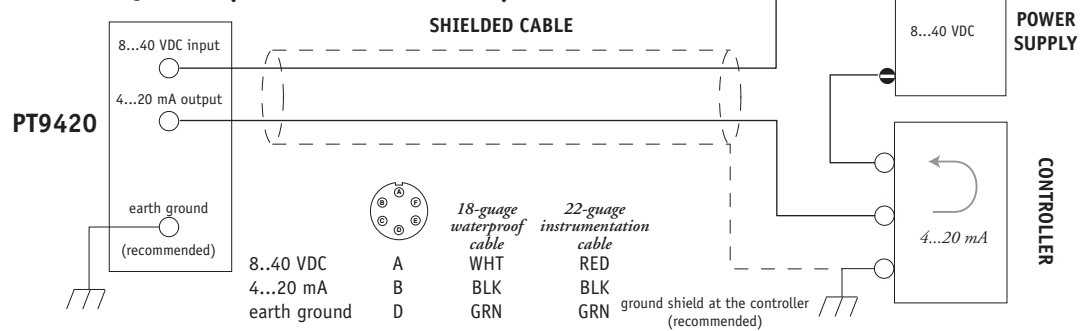

3-Wire System

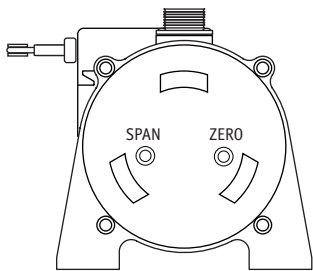
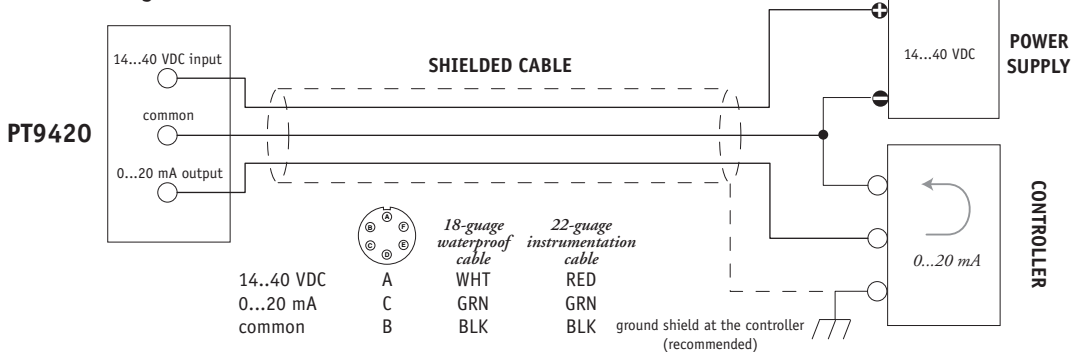

Changing Calibrated Range

- Remove Phillips-head cover screws to reveal zero and span trim pots
- Extend measuring cable to 0/4 mA position and adjust zero pot.
- Extend measuring cable to 20 mA position and adjust span pot
- Repeat steps ii and iii.
- Replace plugs.